

TIA microphone amplifier circuit

Design Goals

Input pressure (Max)	Output Voltage (Max)	Supply		Frequency Response Deviation	
		V_{cc}	V_{ee}	@ 20Hz	@20kHz
100dB SPL(2Pa)	1.228V _{rms}	5V	0V	–0.5dB	–0.1dB

Design Description

This circuit uses an op amp in a transimpedance amplifier configuration to convert the output current from an electret capsule microphone into an output voltage. The common mode voltage of this circuit is constant and set to mid-supply eliminating any input-stage cross over distortion.

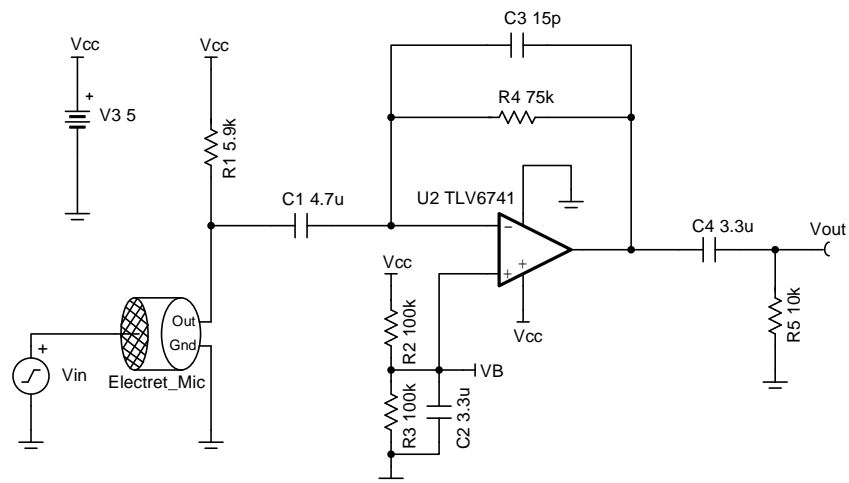

Design Notes

1. Use the op amp in the linear output operating range, which is usually specified under the A_{OL} test conditions.
2. Use low- K capacitors (tantalum, C0G, etc.) and thin film resistors help to decrease distortion.
3. Use a battery to power this circuit to eliminate distortion caused by switching power supplies.
4. Use low value resistors and low noise op amp to achieve high performance low noise designs.
5. The voltage connected to R_1 to bias the microphone does not have to match the supply voltage of the op amp. Using a larger microphone bias voltage allows for a larger value or R_1 which decreases the noise gain of the op amp circuit while still maintaining normal operation of the microphone.
6. Capacitor C_1 should be large enough that its impedance is much less than resistor R_1 at audio frequency. Pay attention to the signal polarity when using tantalum capacitors.

Design Steps

The following microphone is chosen as an example to design this circuit.

Microphone parameter	Value
Sensitivity @ 94dB SPL (1 Pa)	-35 ± 4 dBV
Current Consumption (Max)	0.5mA
Impedance	2.2kΩ
Standard Operating Voltage	2V _{dc}

- Convert the sensitivity to volts per Pascal.

$$10^{\frac{-35\text{dB}}{20}} = 17.78 \text{ mV} / \text{Pa}$$

- Convert volts per Pascal to current per Pascal.

$$\frac{17.78\text{mV} / \text{Pa}}{2.2\text{k}\Omega} = 8.083 \mu\text{A} / \text{Pa}$$

- Max output current occurs at max sound pressure level of 2Pa.

$$I_{\text{Max}} = 2\text{Pa} \times 8.083 \mu\text{A} / \text{Pa} = 16.166 \mu\text{A}$$

- Calculate the value of resistor R₄ to set the gain

$$R_4 = \frac{V_{\text{max}}}{I_{\text{max}}} = \frac{1.228\text{V}}{16.166\mu\text{A}} = 75.961 \text{ k}\Omega \approx 75\text{k}\Omega \text{ (Standard value)}$$

The final signal gain is:

$$\text{Gain} = 20 \times \log \frac{V_{\text{out}}}{V_{\text{in}}} = 20 \times \log \frac{16.166\mu\text{A} \times 75\text{k}\Omega}{2\text{V}} = -4.347 \text{ dB}$$

- Calculate the value for the bias resistor R₁. In the following equation, V_{mic} is the standard operating voltage of the microphone

$$R_1 = \frac{V_{\text{cc}} - V_{\text{mic}}}{I_s} = \frac{5\text{V} - 2\text{V}}{0.5\text{mA}} = 6\text{k}\Omega \approx 5.9 \text{ k}\Omega \text{ (Standard value)}$$

- Calculate the high frequency pole according to the allowed deviation at 20 kHz. In the following equation, G_{pole1} is the gain at frequency "f".

$$f_p = \frac{f}{\sqrt{\left(\frac{1}{G_{\text{pole1}}}\right)^2 - 1}} = \frac{20\text{kHz}}{\sqrt{\left(\frac{1}{-0.1}\right)^2 - 1}} = 131.044 \text{ kHz}$$

- Calculate C₃ based on the pole frequency calculated in step 6.

$$C_3 = \frac{1}{2\pi \times f_p \times R_4} = \frac{1}{2\pi \times 131.044\text{kHz} \times 75\text{k}\Omega} = 16.194 \text{ pF} \approx 15\text{pF} \text{ (Standard value)}$$

- Calculate the corner frequency at low frequency according to the allowed deviation at 20 Hz. In the following equation, G_{pole2} is the gain contributed by each pole at frequency "f" respectively. There are two poles, so divided by two.

$$f_c = f \times \sqrt{\left(\frac{1}{G_{\text{pole2}}}\right)^2 - 1} = 20\text{Hz} \times \sqrt{\left(\frac{1}{-0.5/2}\right)^2 - 1} = 4.868 \text{ Hz}$$

- Calculate the input capacitor C₁ based on the cut off frequency calculated in step 8.

$$C_1 = \frac{1}{2\pi \times R_1 \times f_c} = \frac{1}{2\pi \times 5.9\text{k}\Omega \times 4.868\text{Hz}} = 5.541 \mu\text{F} \approx 4.7 \mu\text{F} \text{ (Standard value)}$$

- Assuming the output load R₅ is 10kΩ, calculate the output capacitor C₄ based on the cut off frequency calculated in step 8.

$$C_4 = \frac{1}{2\pi \times R_5 \times f_c} = \frac{1}{2\pi \times 10\text{k}\Omega \times 4.868\text{Hz}} = 3.269 \mu\text{F} \approx 3.3 \mu\text{F} \text{ (Standard value)}$$

- Set the amplifier input common mode voltage to mid-supply voltage. Select R₂ and R₃ as 100kΩ. The equivalent resistance equals to the parallel combination of the two resistors:

$$R_{\text{eq}} = R_2 \parallel R_3 = 100\text{k}\Omega \parallel 100\text{k}\Omega = 50\text{k}\Omega$$

- Calculate the capacitor C₂ to filter the power supply and resistor noise. Set the cutoff frequency to 1Hz.

$$C_2 = \frac{1}{2\pi \times (R_2 \parallel R_3) \times 1\text{Hz}} = \frac{1}{2\pi \times (100\text{k}\Omega \parallel 100\text{k}\Omega) \times 1\text{Hz}} = 3.183 \mu\text{F} \approx 3.3 \mu\text{F} \text{ (Standard value)}$$

Design Simulations

AC Simulation Results

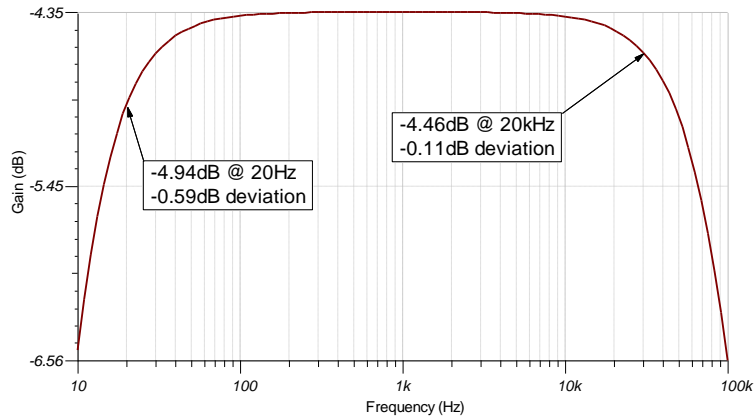

Transient Simulation Results

The input voltage represents the SPL of an input signal to the microphone. A 2 V_{rms} input signal represents 2 Pascal.

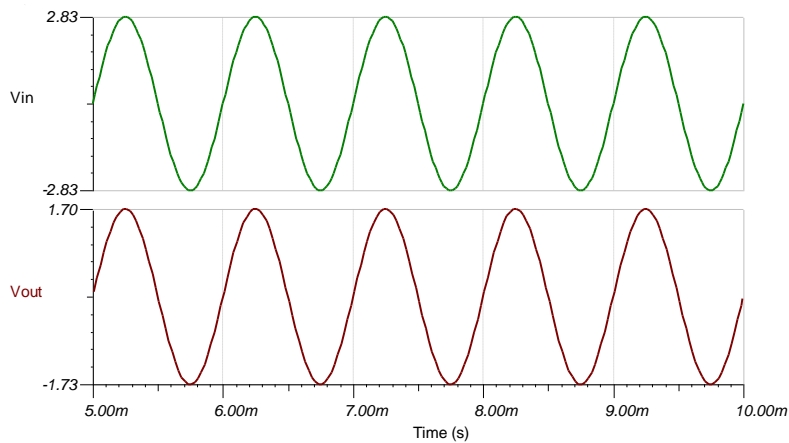

Noise Simulation Results

The following simulation results show 22.39μV_{rms} of noise at 22kHz. The noise is measured at a bandwidth of 22kHz to represent the measured noise using an audio analyzer with the bandwidth set to 22kHz.

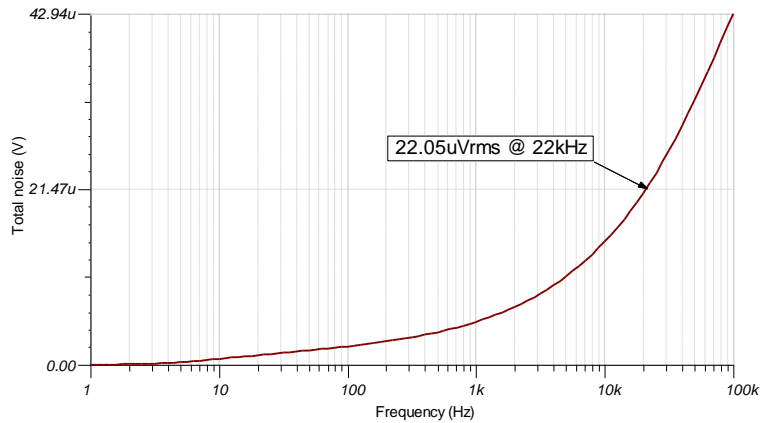

References:

1. [Analog Engineer's Circuit Cookbooks](#)
2. SPICE Simulation File [SBOC526](#)
3. TI Precision Designs [TIPD181](#)
4. [TI Precision Labs](#)

Design Featured Op Amp

TLV6741	
V_{ss}	1.8V to 5.5V
V_{inCM}	V_{ee} to $V_{cc}-1.2V$
V_{out}	Rail-to-rail
V_{os}	150 μ V
I_q	890 μ A/Ch
I_b	10pA
UGBW	10MHz
SR	4.75V/ μ s
#Channels	1
www.ti.com/product/tlv6741	

Design Alternate Op Amp

	OPA172	OPA192
V_{ss}	4.5V to 36V	4.5V to 36V
V_{inCM}	$V_{ee}-0.1V$ to $V_{cc}-2V$	$V_{ee}-0.1V$ to $V_{cc}+0.1V$
V_{out}	Rail-to-rail	Rail-to-rail
V_{os}	$\pm 200\mu$ V	$\pm 5\mu$ V
I_q	1.6mA/Ch	1mA/Ch
I_b	8pA	5pA
UGBW	10MHz	10MHz
SR	10V/ μ s	20V/ μ s
#Channels	1, 2, 4	1, 2, 4
	www.ti.com/product/opa172	www.ti.com/product/opa192

IMPORTANT NOTICE AND DISCLAIMER

TI PROVIDES TECHNICAL AND RELIABILITY DATA (INCLUDING DATA SHEETS), DESIGN RESOURCES (INCLUDING REFERENCE DESIGNS), APPLICATION OR OTHER DESIGN ADVICE, WEB TOOLS, SAFETY INFORMATION, AND OTHER RESOURCES "AS IS" AND WITH ALL FAULTS, AND DISCLAIMS ALL WARRANTIES, EXPRESS AND IMPLIED, INCLUDING WITHOUT LIMITATION ANY IMPLIED WARRANTIES OF MERCHANTABILITY, FITNESS FOR A PARTICULAR PURPOSE OR NON-INFRINGEMENT OF THIRD PARTY INTELLECTUAL PROPERTY RIGHTS.

These resources are intended for skilled developers designing with TI products. You are solely responsible for (1) selecting the appropriate TI products for your application, (2) designing, validating and testing your application, and (3) ensuring your application meets applicable standards, and any other safety, security, regulatory or other requirements.

These resources are subject to change without notice. TI grants you permission to use these resources only for development of an application that uses the TI products described in the resource. Other reproduction and display of these resources is prohibited. No license is granted to any other TI intellectual property right or to any third party intellectual property right. TI disclaims responsibility for, and you will fully indemnify TI and its representatives against, any claims, damages, costs, losses, and liabilities arising out of your use of these resources.

TI's products are provided subject to [TI's Terms of Sale](#) or other applicable terms available either on ti.com or provided in conjunction with such TI products. TI's provision of these resources does not expand or otherwise alter TI's applicable warranties or warranty disclaimers for TI products.

TI objects to and rejects any additional or different terms you may have proposed.

Mailing Address: Texas Instruments, Post Office Box 655303, Dallas, Texas 75265
Copyright © 2021, Texas Instruments Incorporated