

The ISO72x Family of High-Speed Digital Isolators

Kevin Gingerich and Chris Sterzik

HPL - Interface

ABSTRACT

This application report provides an overview of the need for, implementations of, and characteristics of electrical isolation in high-speed digital circuits. It discusses the advantages and disadvantages of optical, magnetic (inductive), and electrical (capacitive) signal transmission across an isolation barrier with particular focus on the capacitor-coupled technique used in the ISO72x family of digital isolators.

Contents

1	Introduction	2
2	The Need for Circuit Isolation	2
3	Circuit Isolators.....	4
4	Conclusion	10
5	References	11

List of Figures

1	Possible Circuit Path Between Power Supply and Patient.....	2
2	Isolation Between High-Voltage and Low-Voltage Circuits.....	3
3	Ground Potential Difference Between Devices	3
4	Ground Loops Between Nodes Broken With Isolation.....	4
5	Basic Optocoupler Mechanism	4
6	Inductive Isolation.....	5
7	GMR Diagram	6
8	Capacitive Coupling	6
9	ISO72x and ISO72xM Block Diagram	7
10	Two-Terminal Isolation Voltage Test.....	7
11	Barrier Capacitance	8
12	Sensitivity to External Magnetic Fields	10

List of Tables

1	Isolation Performance	8
2	Transient Immunity Performance	8
3	Quiescent Power-Supply Current.....	9
4	MTTF Reliability Measurements	9
5	Raw Reliability Data	10
6	Parameters for Different Digital Isolators.....	11

Trademarks

iCoupler is a trademark of Analog Devices, Inc..
 Isoloop is a trademark of Nonvolatile Electronics, Incorporated.
 All other trademarks are the property of their respective owners.

1 Introduction

Isolation is the separation of one section from undesired influences of other sections. In electrical circuits, dielectrics isolate circuits by blocking direct current (dc). How then can isolated circuits operate within a larger electrical system? The answer to this question is the subject of this application report.

The options for isolated signaling have grown with product introductions from Texas Instruments and various suppliers, complicating product selection for the designer. This report identifies the key characteristics of isolators and clarifies the differences and similarities between products.

After a review of the basic needs for circuit isolation, the three methods of signal transfer across dielectrics and analog versus digital isolators are discussed. Examples of each type of digital isolator are described and compared.

2 The Need for Circuit Isolation

The principle reason for isolating circuits is protection from hazardous voltages and currents. In the medical application example of [Figure 1](#), where a small amount of AC current may be fatal, a barrier is required for patient protection. Isolation also protects sensitive circuits from high voltages found in industrial applications. The industrial example of [Figure 2](#) is simply a high-voltage measurement. Isolating the sensors from the actual high voltage makes the measurement possible with low-voltage circuits.

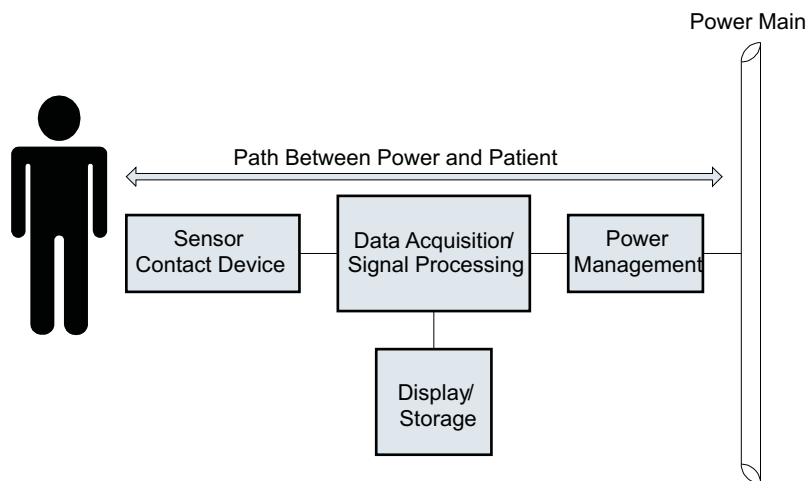

Figure 1. Possible Circuit Path Between Power Supply and Patient

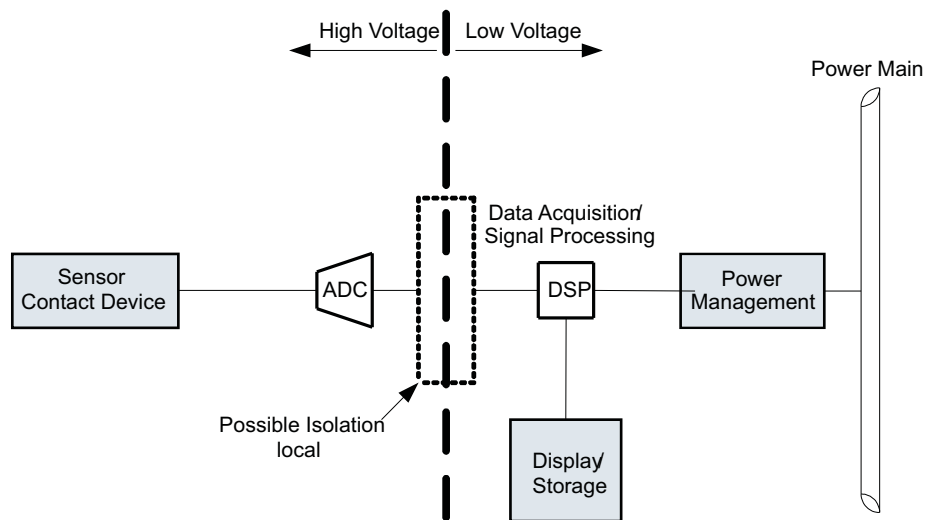

Figure 2. Isolation Between High-Voltage and Low-Voltage Circuits

The principle of protection is isolation of large voltage potentials that may occur between systems or circuits, as shown in the cabled application of [Figure 3](#), where a large distance can separate a driver and receiver. Over such long distances, the grounds may be at different potentials. With isolation, the potential difference forms across the isolator and not across sensitive circuitry.

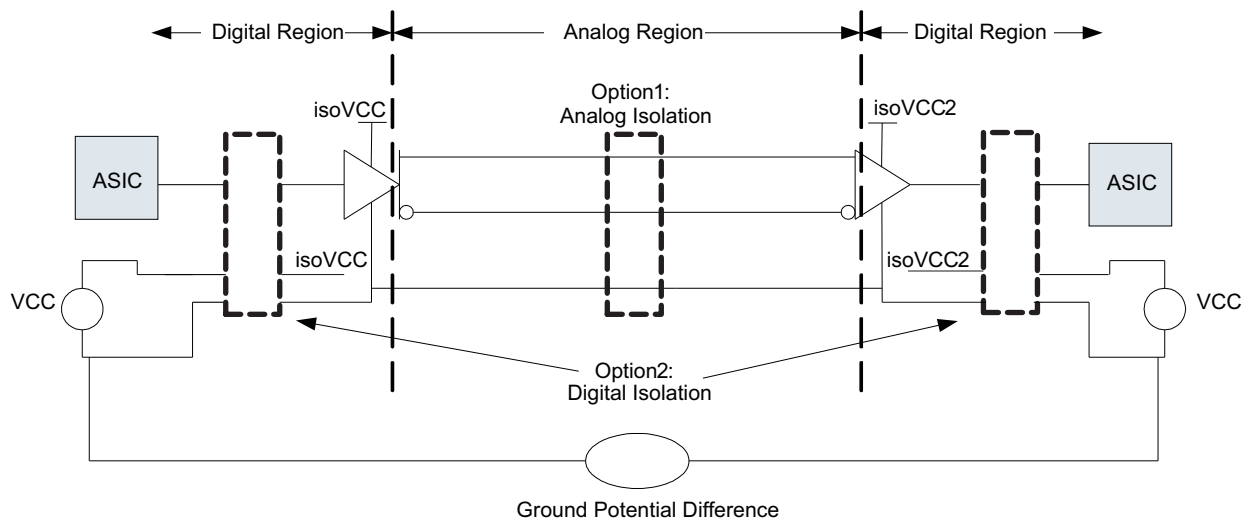

Figure 3. Ground Potential Difference Between Devices

As illustrated in [Figure 4](#), isolation *breaks* the loop formed by the circuit paths with high impedance relative to the other circuit components. By breaking the loop, noise voltage appears across the isolation barrier rather than at the receiver or more sensitive components. High levels of noise voltage can couple from external current or voltage sources such as induction motors and lightning.

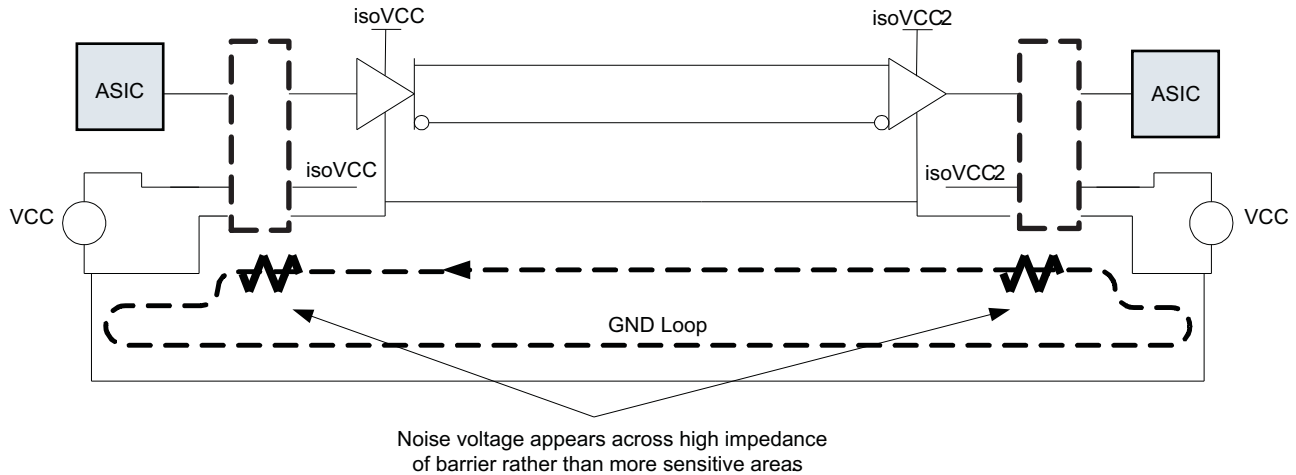

Figure 4. Ground Loops Between Nodes Broken With Isolation

3 Circuit Isolators

Circuit isolators block low-frequency current between circuits while allowing analog or digital signal transfer via electromagnetic or optical links. Digital isolators transfer binary signals and analog isolators transfer continuous signals across the isolation barrier. In both analog and digital isolators, working and peak voltage ratings and common-mode transient immunity are the significant characteristics of the isolation barrier. When isolating digital signals, the significant characteristics of the isolation circuit are input and output logic voltage levels, signaling rate, data run length, and fail-safe responses .

Traditionally, transformers, capacitors, or the photo-diode-transistor isolate and discrete circuits condition the input and output signals for a particular need. While effective, this method is not portable from application to application. Although this will likely remain the case for analog isolators, a new generation of digital isolators has appeared in the market that uses innovative circuitry to isolate standard digital signals at signaling rates of dc to over 100 Mbps. These general-purpose digital isolators each have strengths and weaknesses. The following paragraphs present the different technologies and compare specific products with the new ISO72x from Texas Instruments.

3.1 Optical Coupling

Optical coupling is the transmission of light across a transparent nonconductive barrier, such as an air gap, to achieve isolation. Figure 5 shows principle components of a digital isolator. The current driver that takes the digital input and converts the signal into a current to drive the light-emitting diode (LED). The output buffer translates the current output of the photo-detector into a digital output.

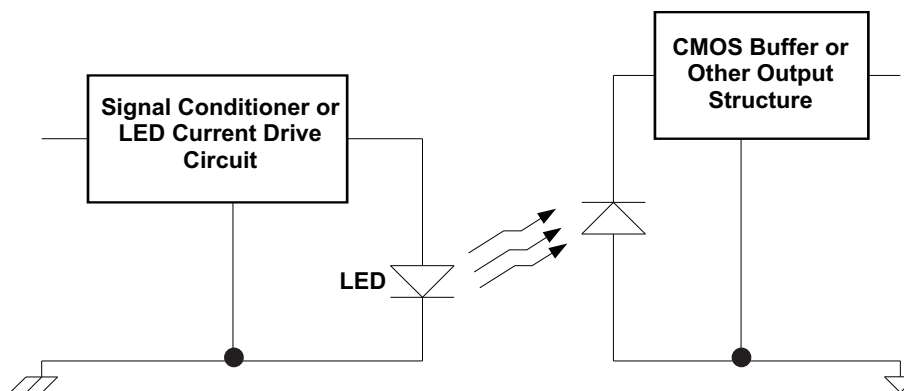

Figure 5. Basic Optocoupler Mechanism

The main benefits of optocoupling are that light is inherently immune to external electric or magnetic fields, and optocoupling allows for transfer of steady-state information. The disadvantages of optocouplers include speed limitations, power dissipation, and the degradation of the LED.

The maximum signaling rate of an optocoupler depends on how quickly the LED can turn on and off. Based on what is currently available, the fastest optocoupler is the HCPL-0723, which can achieve signaling rates of 50 Mbps.

The current transfer ratio (CTR) from input to output is a key characteristic for optocouplers, and the LED generally requires 10 mA of input current for high-speed digital transfers. This ratio measures the current used to drive the LED and the resulting current generated by the phototransistor. Over time, the LED becomes less efficient, requiring more current to generate the same level of light and the same level of output current from the phototransistor. In digital isolators, internal circuitry controls the LED drive current, and the user cannot compensate for a decreasing CTR. The LED strength diminishes, and with time, the isolator is no longer functional.

3.2 Inductive Coupling

Inductive coupling uses a changing magnetic field between two coils to communicate across an isolation barrier. The most common example is the transformer where the strength of the magnetic field depends on the coil structure (number of turns/unit length) of the primary and secondary windings, the permeability of the magnetic core, and the current magnitude. Figure 6 shows a transformer with signal-conditioning circuit blocks.

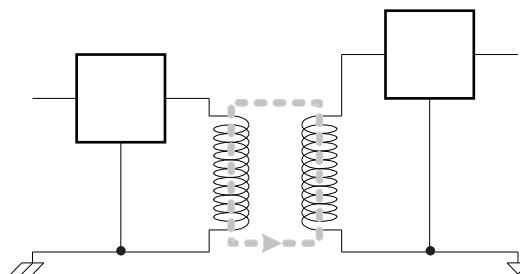
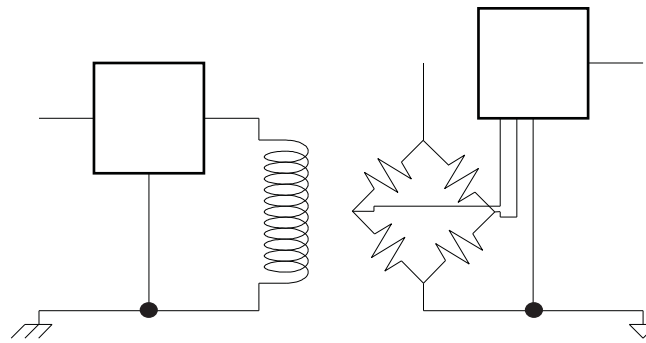

Figure 6. Inductive Isolation

The advantage of inductive coupling is the possible difference in common-mode and differential transfer characteristics. Careful transformer design allows noise and signal frequencies to overlap but presents high common-mode impedance to the noise and low differential impedance to the signal. Another advantage is that the signal energy transfer can be nearly 100% efficient enabling low-power isolators.

The main concern with inductive coupling is susceptibility to external magnetic fields (noise). Industrial applications often require isolation in magnetic fields, such as motor control. Another concern in transformer transmission of digital is the data run-length. A signal transformer passes signals within a certain range of frequencies and amplitudes with tolerable distortion. Data run-length limiting or clock encoding is required to keep the signal within the usable bandwidth of the transformer. General-purpose digital isolators which use inductive coupling require signal processing to transfer and reconstruct the digital signal along with a means of transferring low-frequency signals (long strings of 1s or 0s). Both the Isoloop™ from NVE/Avago and iCoupler™ from ADI use encoding and provide digital isolation solutions which support an operating range from dc to 100 Mbps.

The ADuM1100 is an example of the iCoupler™ technology from ADI. The ADuM1100 uses a basic transformer to transfer information across an isolation barrier. The Isoloop™ technology, such as the HCPL-0900, replaces the secondary coil with a resistor network as Figure 7 illustrates. The resistors are made of a GMR (giant magneto-resistor) material so that when a magnetic field is applied, the resistance changes. Circuitry senses the change in resistance, and conditions it for output. The technology when first introduced to the market provided a substantial improvement in ac performance over existing optocouplers. These Isoloop™ devices have now been surpassed with the more recent introduction of digital isolators from ADI and the ISO72x family of devices from Texas Instruments.

Figure 7. GMR Diagram

3.3 Capacitive Coupling

Capacitive coupling uses a changing electric field to transmit information across the isolation barrier. The material between the capacitor plates is a dielectric insulator and forms the isolation barrier. The plate size, distance between the plates, and the dielectric material determine the electrical properties.

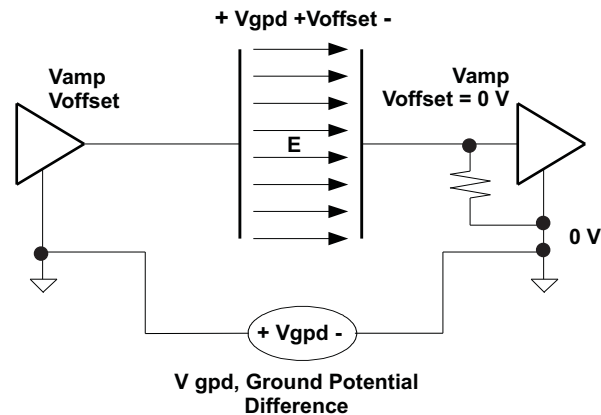
Figure 8. Capacitive Coupling

The benefits of using a capacitive isolation barrier are efficiency, in both size and energy transfer, and immunity to magnetic fields. The former enables low-power and cost-effective integrated isolation circuits. The latter enables operation in saturated or dense magnetic field environments.

The disadvantage of capacitive coupling is that, unlike the transformer, there is no differential signal and the noise and the signal share the same transmission path. This requires that the signal frequencies be well above the expected frequency of noise so that the barrier capacitance presents low impedance to the signal and high impedance to the noise. As with inductive coupling, capacitive coupling does not pass steady-state signals and requires clock-encoded data.

3.3.1 The ISO721 From Texas Instruments

The Texas Instruments ISO72x family of isolators use capacitive coupling. The capacitive coupling solution uses proven and cost-effective manufacturing processes and provides an inherent immunity to magnetic fields.

To provide transfer of steady-state information, the ISO72x uses both a high-signaling rate and low-signaling rate channel to communicate as shown in [Figure 9](#). The high-signaling rate channel is not encoded and it transmits data transitions across the barrier after a single-ended-to-differential conversion. The low-signaling rate channel encodes the data in a pulse-width modulated format and transmits the data across the barrier differentially, ensuring the accurate communication of steady-state conditions (long string of 1s or 0s).

Differential transfer of the single-ended logic signal across the isolation barrier allows low-level signals and small coupling capacitance. This appears high impedance to common-mode noise and, with the common-mode noise rejection of the receiver, gives excellent transient immunity, the primary concern in capacitive coupling of signals.

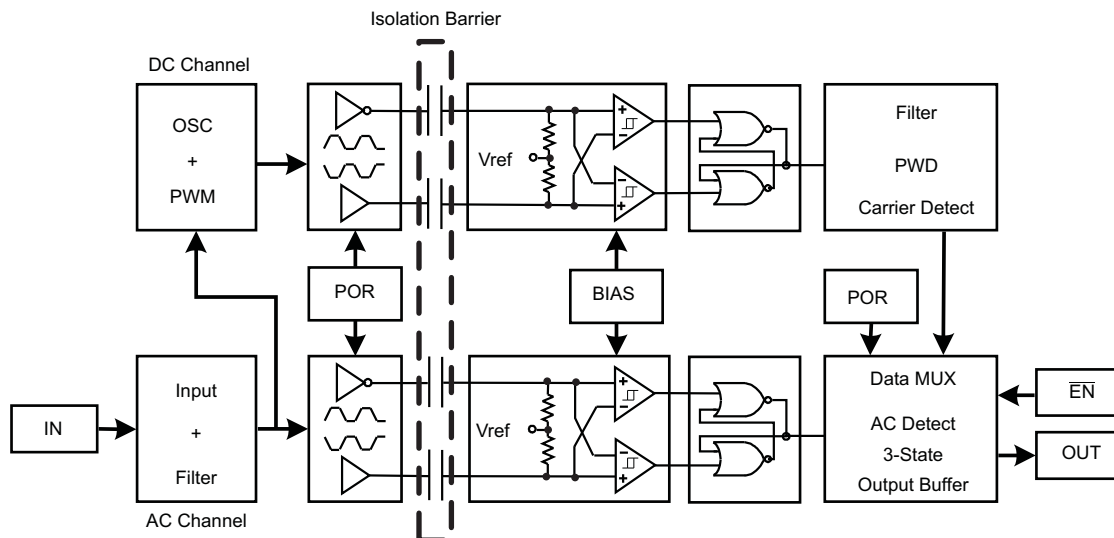

Figure 9. ISO72x and ISO72xM Block Diagram

3.4 Isolation Performance

Three main standards validate a claim of isolation protection. These are the UL 1577, IEC 60747-5-2, and the CSA. Each of these standards varies slightly, but all provide a standard for comparing isolation performance. The tests from IEC, UL, and CSA verify the voltage beyond which the dielectric between the input and output breaks down. Applying these standards is quite simple, because the test criteria have nothing to do with method of isolation. Figure 10 illustrates how isolation testing treats the isolators as two-terminal devices. Although the physical structures are different for each device, the isolation tests determine at what voltage the dielectric breaks down.

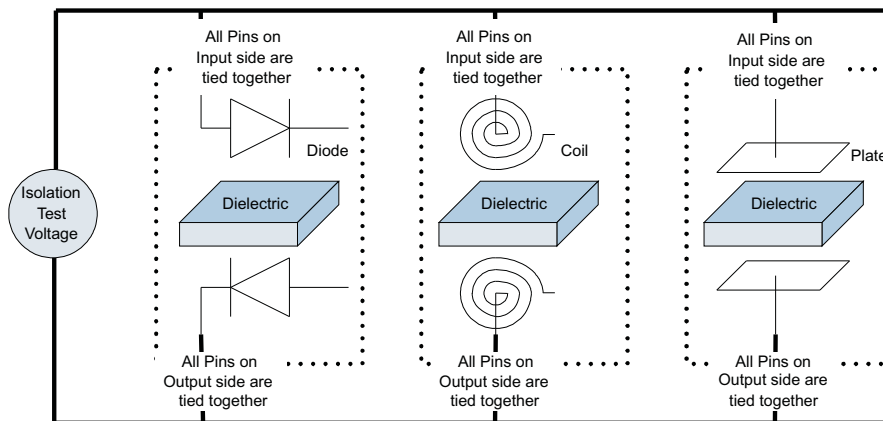

Figure 10. Two-Terminal Isolation Voltage Test

UL 1577, IEC 60747-5-2, IEC 61010-1, and CSA tested the ISO72x family isolation. Table 1 shows the isolation performance of the five devices representing the three isolation techniques.

Table 1. Isolation Performance

PART	TECHNOLOGY	UL 1577 (VRMS)	IEC 60747-5-2, V_{IORM} (V_{PEAK})
ISO721	Capacitive	2500	560
ADuM1100	Inductive	2500	560
HCPL-0900	Inductive	2500	Not Approved ⁽¹⁾
HCPL-0721 HCPL-0723	Optical	3750	560

⁽¹⁾ At the time of this publication, the HCPL-0900 data sheet does not include IEC 60747-5-2.

All three tests, UL, CSA, and IEC, test the quality of the isolation barrier. The UL and CSA tests are stress tests that apply the dielectric breakdown voltage set by the manufacturer for a set time. A failure is the breakdown of the dielectric during the test. The IEC test uses a phenomenon called partial discharge to detect the voids within a dielectric. A large voltage that is a function of the working voltage defined by the manufacturer is applied to the device and then lowered to another voltage level, V_m . It is during this lower voltage application that the device under test is monitored for partial discharges of voids within the dielectric. These voids lead to the eventual breakdown of the entire dielectric.

3.5 Transient Immunity

High-slew-rate (high-frequency) transients can corrupt data transmission across an isolation barrier. The barrier capacitance provides a path, as shown in Figure 11, for transient events to cross the isolation barrier and corrupt the output waveform. A Faraday shield can divert some of this displacement current in optocouplers or inductive couplers away from important output structures.

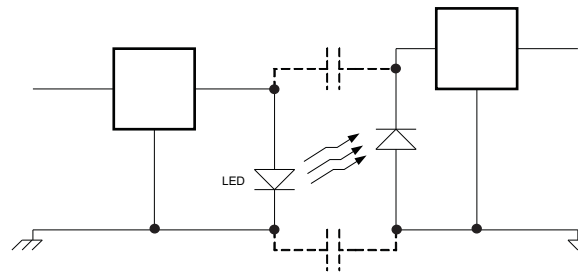

Figure 11. Barrier Capacitance

In capacitive coupling solutions, the Faraday shield is not a viable solution. A Faraday shield would block the electric field used for data transmission in addition to transients. In order to provide transient immunity, the ISO72x family of capacitive isolators transfers only transitions to the data signal representing only the highest frequency energy in the signal. This allows a small coupling capacitance that is high impedance to noise frequencies. Additional noise derives from the differential technique to transmit data across the barrier. Figure 9 shows four signals that cross the capacitive barrier; two contain the low-signaling rate information and two contain the high-signaling rate information. By using a differential technique, any remaining common-mode transients that cross the barrier are seen on both the true and complementary signals and the differential receiver rejects it. As shown in Table 2, the transient immunity of the ISO72x family is as high as any of the comparable devices are up to 25 kV/ μ s.

Table 2. Transient Immunity Performance

PART	TECHNOLOGY	TRANSIENT IMMUNITY (kV/ μ s)
ISO721	Capacitive	25
ADuM1100	Inductive	25
HCPL-0900	Inductive	15
HCPL-0721 HCPL-0723	Optical	10

3.6 Fail-Safe

One concern about data line circuits and digital isolators is the output state on loss of the input signal. Input loss may occur from disconnecting cables or simply removing power from the input side of the isolator. Fail-safe refers to a determinant or known output state under loss of the input. The ISO72x family uses a periodic pulse to determine if the input structure has power on and is working. If the output side of the isolator does not receive a pulse after 4 μ s, then the output is set to a high state. The ADuM1100 from ADI also incorporates a fail-safe circuit in the output portion of the IC. The optical solutions from Avago Technologies (HCPL-0721 and -0723) make no mention of fail-safe, and the inductive GMR solution (HCPL-0900) explicitly describes the indeterminate nature of the output during power sequencing.

3.7 Power Consumption

Beyond the efficiency of the signal transfer across the barrier, the design of the input and output conditioning circuitry has the most to do with power consumption. As shown in [Table 3](#), the optocouplers use more power than the inductive or capacitive examples.

Table 3. Quiescent Power-Supply Current

Part	Coupling Technology	Vcc1 and Vcc2 (V)	Icc1 (mA)	Icc2 (mA)	Power (mW)
ISO721	Capacitive	5	1	11	60
		3.3	0.5	6	21.5
ADuM1100	Magnetic	5	0.8	0.06	4.3
		3.3	0.3	0.04	1.2
HCPL-0900	Magnetic	5	0.018	6	30
		3.3	0.01	4	13.2
HCPL-0721	Optical	5 Only	10 ⁽¹⁾	9	95
HCPL-0723	Optical	5 Only	10 ⁽¹⁾	17.5 ⁽²⁾	137.5

⁽¹⁾ 10 mA is for the logic-low input state. When the logic input state is high, then the current consumption drops to 3 mA.

⁽²⁾ 17.5 mA is for the logic-low input state. When the logic input state is high, then the current consumption drops to 16.5 mA.

3.8 Reliability

Mean time to failure (MTTF) is a standard measure for reliability of semiconductor devices. For digital isolators, this measure represents the reliability of both the integrated circuit and the isolation mechanism. [Table 4](#) shows the MTTF of an optical, inductive, and capacitive digital isolator. The ISO721 is very reliable when compared to inductive and optical solutions.

Table 4. MTTF Reliability Measurements

Part	Coupling Technology	Ambient Temperature (°C)	Typical, 60% Confidence		Typical, 90% Confidence	
			MTTF (Hr/Fail.)	FITs (Fail./10 ⁹ Hr)	MTTF (Hr/Fail.)	FITs (Fail./10 ⁹ Hr)
ISO721	Capacitive	125	1,246,889	802	504,408	1983
HCPL-0900	Inductive	125	288,118	3471	114,654	8722
HCPL-0721	Optical	125	174,617	5727	69,487	14,391

The ADuM1100 reliability data sheet does not explicitly state the MTTF, but it does provide the results of the reliability testing. [Table 5](#) shows the parameters of the reliability testing for both the ISO721 and the ADuM1100.

Table 5. Raw Reliability Data

Part	Coupling Technology	Junction Temperature (°C)	Duration (Hr)	Sample Size	Rejects
ISO721	Capacitive	150<T _J <175	1000	344 (3 lots:116,116,112)	0
ADuM1100	Inductive	150<T _J <175	500	231 (77 from 3 lots)	0

3.9 External Magnetic Field Immunity

Figure 12 compares the magnetic field immunity of the ADuM1100 and the ISO72x (no data is available for the HCPL-0900). Although both examples are relatively immune to magnetic fields, the ISO72x provides significantly more margin. As previously mentioned, the barrier circuit of optocouplers is inherently immune from susceptibility to external magnetic fields.

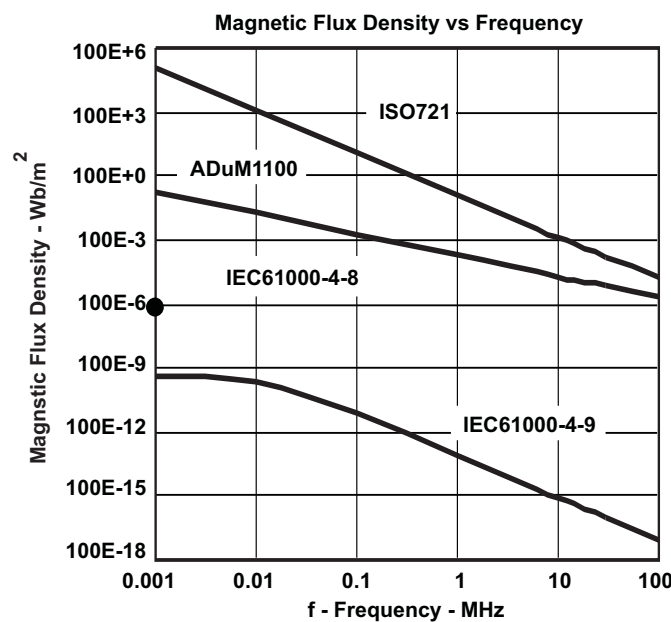

Figure 12. Sensitivity to External Magnetic Fields

4 Conclusion

Noise reduction and protection drive the use of isolators in electrical circuits where isolators break ground loops and isolate ground potential differences. The designer now has many choices for isolation of digital signals including the ISO72x family from Texas Instruments that rates highly in the important characteristics of signaling rate, dielectric breakdown voltage, transient immunity, power consumption, magnetic field immunity, and reliability. Table 6 summarizes these characteristics for the examples discussed in this report.

We currently recommend the ISO7710 from our newest ISO77xx family of digital isolators with improved isolation ratings.

Table 6. Parameters for Different Digital Isolators

Part	Coupling Technology	V _{CC} (V)	Signaling Rate (Mbps)	UL1577 (VRMS)	Transient Immunity (kV/μs)	Power (mW)	Magnetic Field Immunity	Reliability (MTTF), 60% Confidence (Hr/Fail.)
ISO721	Capacitive	3.3 or 5	150	2500	25	60	+	1.25M
ADuM1100	Inductive	5	100	2500	25	4.3		
		3.3	50			1.2		
HCPL-0900	Inductive	5	100	2500	15	30		288k
		3.3				13.2		
HCPL-0721	Optical	5	25	3750	10	95	++	175k
HCPL-0723	Optical	5	50			137.5	++	

5 References

1. *Noise Reduction Techniques In Electronic Systems 2nd Edition*, H. W. Ott
2. *The Designer's Guide to Electronic Compatibility*, D. Girke, B. Kimmel,
3. *HCPL-0721 Data sheet*, Avago Technologies
4. *HCPL-0723 Data sheet*, Avago Technologies
5. *HCPL-0900 Data sheet*, Avago Technologies
6. *Optocoupler Input Drive Circuits*, AN3001 Fairchild Application Note
7. *ADuM1100 Data sheet Revision E*, Analog Devices
8. Texas Instruments, [ISO72x Single Channel High-Speed Digital Isolators data sheet](#)
9. Texas Instruments, [ISO72x Digital Isolator Magnetic-Field Immunity application report](#)
10. *Sensors*, January 1999, *A System Designer's Guide to Isolation Devices*, P. Pickering
11. *40ns Propagation Delay CMOS Optocouplers Reliability Datasheet*, July 2002, Agilent (Avago)
12. *Agilent HCPL-0900/0930/0931, High-Speed Digital Optocoupler, Reliability Datasheet*, May 2005, Agilent (Avago)
13. *ADuM1100 Fab Transfer, Reliability Report*, December 2002, Analog Devices, Inc.

Revision History

NOTE: Page numbers for previous revisions may differ from page numbers in the current version.

Changes from Original (January 2006) to A Revision	Page
• Added reference to the ISO7710 device and ISO77xx family of digital isolators in the <i>Conclusion</i>	10

IMPORTANT NOTICE FOR TI DESIGN INFORMATION AND RESOURCES

Texas Instruments Incorporated ("TI") technical, application or other design advice, services or information, including, but not limited to, reference designs and materials relating to evaluation modules, (collectively, "TI Resources") are intended to assist designers who are developing applications that incorporate TI products; by downloading, accessing or using any particular TI Resource in any way, you (individually or, if you are acting on behalf of a company, your company) agree to use it solely for this purpose and subject to the terms of this Notice.

TI's provision of TI Resources does not expand or otherwise alter TI's applicable published warranties or warranty disclaimers for TI products, and no additional obligations or liabilities arise from TI providing such TI Resources. TI reserves the right to make corrections, enhancements, improvements and other changes to its TI Resources.

You understand and agree that you remain responsible for using your independent analysis, evaluation and judgment in designing your applications and that you have full and exclusive responsibility to assure the safety of your applications and compliance of your applications (and of all TI products used in or for your applications) with all applicable regulations, laws and other applicable requirements. You represent that, with respect to your applications, you have all the necessary expertise to create and implement safeguards that (1) anticipate dangerous consequences of failures, (2) monitor failures and their consequences, and (3) lessen the likelihood of failures that might cause harm and take appropriate actions. You agree that prior to using or distributing any applications that include TI products, you will thoroughly test such applications and the functionality of such TI products as used in such applications. TI has not conducted any testing other than that specifically described in the published documentation for a particular TI Resource.

You are authorized to use, copy and modify any individual TI Resource only in connection with the development of applications that include the TI product(s) identified in such TI Resource. NO OTHER LICENSE, EXPRESS OR IMPLIED, BY ESTOPPEL OR OTHERWISE TO ANY OTHER TI INTELLECTUAL PROPERTY RIGHT, AND NO LICENSE TO ANY TECHNOLOGY OR INTELLECTUAL PROPERTY RIGHT OF TI OR ANY THIRD PARTY IS GRANTED HEREIN, including but not limited to any patent right, copyright, mask work right, or other intellectual property right relating to any combination, machine, or process in which TI products or services are used. Information regarding or referencing third-party products or services does not constitute a license to use such products or services, or a warranty or endorsement thereof. Use of TI Resources may require a license from a third party under the patents or other intellectual property of the third party, or a license from TI under the patents or other intellectual property of TI.

TI RESOURCES ARE PROVIDED "AS IS" AND WITH ALL FAULTS. TI DISCLAIMS ALL OTHER WARRANTIES OR REPRESENTATIONS, EXPRESS OR IMPLIED, REGARDING TI RESOURCES OR USE THEREOF, INCLUDING BUT NOT LIMITED TO ACCURACY OR COMPLETENESS, TITLE, ANY EPIDEMIC FAILURE WARRANTY AND ANY IMPLIED WARRANTIES OF MERCHANTABILITY, FITNESS FOR A PARTICULAR PURPOSE, AND NON-INFRINGEMENT OF ANY THIRD PARTY INTELLECTUAL PROPERTY RIGHTS.

TI SHALL NOT BE LIABLE FOR AND SHALL NOT DEFEND OR INDEMNIFY YOU AGAINST ANY CLAIM, INCLUDING BUT NOT LIMITED TO ANY INFRINGEMENT CLAIM THAT RELATES TO OR IS BASED ON ANY COMBINATION OF PRODUCTS EVEN IF DESCRIBED IN TI RESOURCES OR OTHERWISE. IN NO EVENT SHALL TI BE LIABLE FOR ANY ACTUAL, DIRECT, SPECIAL, COLLATERAL, INDIRECT, PUNITIVE, INCIDENTAL, CONSEQUENTIAL OR EXEMPLARY DAMAGES IN CONNECTION WITH OR ARISING OUT OF TI RESOURCES OR USE THEREOF, AND REGARDLESS OF WHETHER TI HAS BEEN ADVISED OF THE POSSIBILITY OF SUCH DAMAGES.

You agree to fully indemnify TI and its representatives against any damages, costs, losses, and/or liabilities arising out of your non-compliance with the terms and provisions of this Notice.

This Notice applies to TI Resources. Additional terms apply to the use and purchase of certain types of materials, TI products and services. These include; without limitation, TI's standard terms for semiconductor products (<http://www.ti.com/sc/docs/stdterms.htm>), [evaluation modules](#), and [samples](http://www.ti.com/sc/docs/sampterm.htm) (<http://www.ti.com/sc/docs/sampterm.htm>).

Mailing Address: Texas Instruments, Post Office Box 655303, Dallas, Texas 75265
Copyright © 2018, Texas Instruments Incorporated