

Space-Grade, 30-krad, Isolated RS-422 Serial Transceiver Circuit



Alfred Chong

Design Goals

Parameter	Design Requirement
Bit rate	100kbps to 10Mbps
Bus length	12M to 1500M
Maximum Total Ionizing Dose	30krad(Si)
Maximum SEL to LET	43MeV × cm ² /mg
Isolation voltage	3000V _{RMS} per UL1577

Design Description

In spacecraft applications RS-422 might be used as a bus and payload *telecommand and control* interfaces. RS-422 was designed as serial communication methods to convey information between equipment by using balanced and differential twisted-pair cable. RS-422 is specified for multi-drop applications where only one driver connects up to 10 receivers through a single differential twisted bus. The following figure shows a typical half-duplex isolated RS-422 interface circuit.

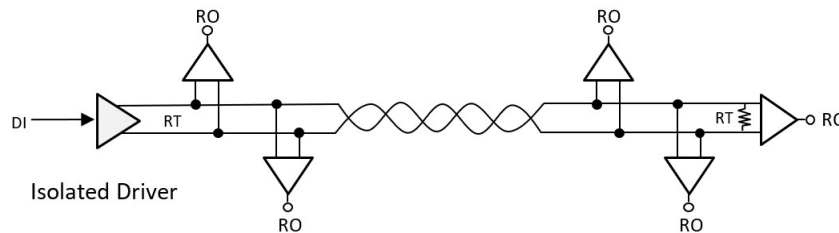

The following circuit uses the ISOS141-SEP digital isolator and SN65C1168E-SEP transceiver devices to achieve a space-grade isolated RS-422 driver.

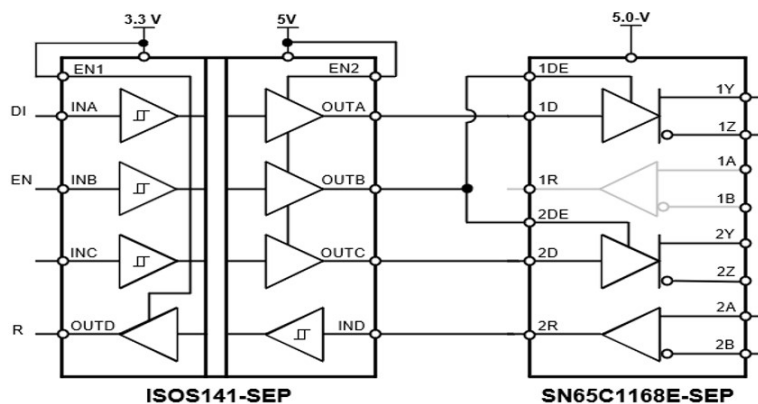

Design Notes

The previous circuit uses the SN65C1168E-SEP driver to create an isolated RS-422 driver to isolate the primary device from the secondary devices. SN65C1168E-SEP consists of two receivers and can be used as secondary devices.

Design Steps

- Determine signaling rate versus cable length

RS-422 system can transmit up to 10Mbps, or over a 1500-m cable at a lower signaling rate. The signal rate is reciprocal to the cable length. Hence, it is important to figure out the maximum signal rate for a given cable length or vice versa. The following figure shows the RS-422 recommended signal rate over the cable length in its annex.

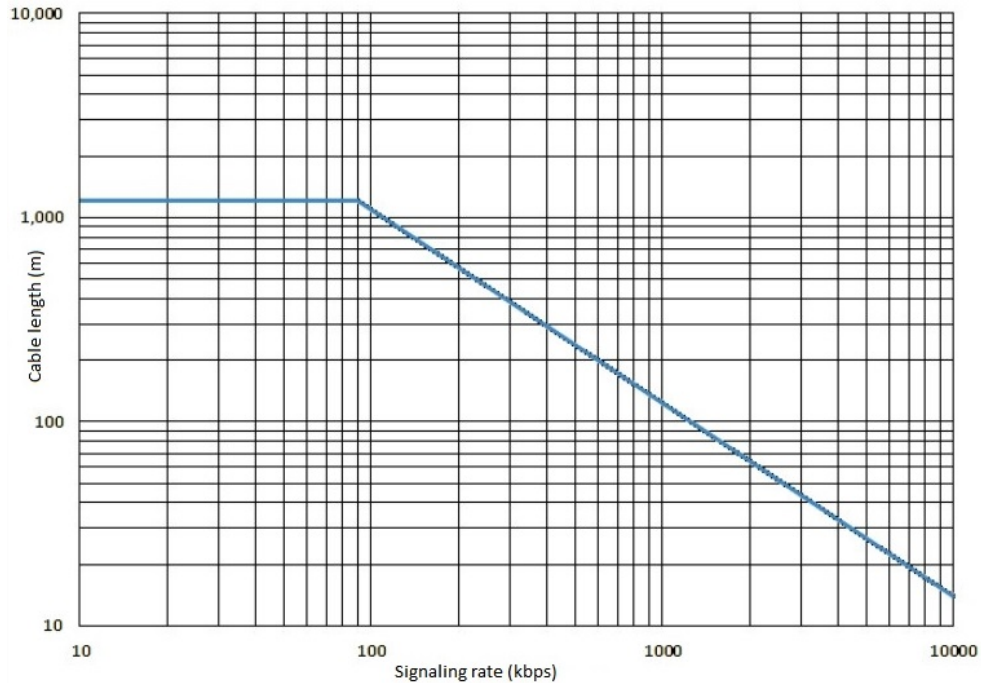

This system design uses a 1500-m cable. From the previous figure, the maximum recommended signal rate is 90kbps.

- Calculate the path delay
 Path delay = Propagation delay of digital isolator + Propagation of RS-422 TX to bus + Propagation delay of wire
 + Propagation delay of bus to RS-422 RX Calculate bit time

Parameter	Conditions	Typ (ns)	MAX (ns)
Propagation delay of ISOS-141-SEP	With $R_L = 50\Omega$, $C_L = 15\text{pF}$	10.7	16
Propagation delay of TX to bus	With $R_L = 50\Omega$, $C_L = 40\text{pF}$	8	16
Propagation delay of 1500-m wire	Approximate delay is 5ns/m (Typ), 5.3ns/m (Max)	7500	7950
Propagation delay of bus to RX	With $R_L = 50\Omega$, $C_L = 50\text{pF}$	15	27

$$\text{Path delay (Typ)} = 10.7 + 8 + 7500 + 15 = 7534\text{ns}$$

$$\text{Path delay (Max)} = 16 + 16 + 7950 + 27 = 8109\text{ns}$$

- Calculate bit time

$$\text{Bit time} = \frac{1}{\text{Bit rate}} = \frac{1}{90\text{kbps}} = 11100\text{ns}$$
- Check path delay < bit time
- This design meets the timing requirement as the approximate worst-case round-trip delay is 8109ns which is less than 11100ns.

Note: If the path delay is greater than the bit time, the following options apply:

1. Pick components with shorter propagation delays
 2. Shorten the cable length
 3. Lower the maximum signaling rate
- It is recommended to place a 120-Ω termination resistor at the other end from the driver.

Reference

Design Featured ISOS141_SEP Digital Isolator

ISOS141-SEP	
VCC1, VCC2	2.25 V to 5.5 V
Data-rate	10Mbps
Propagation delay	10.7ns to 16ns
TID Characterized (ELDRS-Free)	30krad(Si)
TID RLAT, RHA	30krad(Si)
CMTI	±100kV/μs
VISO	3000 V _{RMS}
http://www.ti.com/product/ISOS141-SEP	

Design Featured SN65C1168E-SEP RS-422 Transceiver

SN65C1168E-SEP	
VCC1	4.5 V to 5.5 V
Data-rate	1MHz
TID Characterized (ELDRS-Free)	30krad(Si)
TID RLAT, RHA	20krad(Si)
Common Mode Range	-7 V to 7 V
http://www.ti.com/product/SN65C1168E-SEP	

IMPORTANT NOTICE AND DISCLAIMER

TI PROVIDES TECHNICAL AND RELIABILITY DATA (INCLUDING DATA SHEETS), DESIGN RESOURCES (INCLUDING REFERENCE DESIGNS), APPLICATION OR OTHER DESIGN ADVICE, WEB TOOLS, SAFETY INFORMATION, AND OTHER RESOURCES "AS IS" AND WITH ALL FAULTS, AND DISCLAIMS ALL WARRANTIES, EXPRESS AND IMPLIED, INCLUDING WITHOUT LIMITATION ANY IMPLIED WARRANTIES OF MERCHANTABILITY, FITNESS FOR A PARTICULAR PURPOSE OR NON-INFRINGEMENT OF THIRD PARTY INTELLECTUAL PROPERTY RIGHTS.

These resources are intended for skilled developers designing with TI products. You are solely responsible for (1) selecting the appropriate TI products for your application, (2) designing, validating and testing your application, and (3) ensuring your application meets applicable standards, and any other safety, security, regulatory or other requirements.

These resources are subject to change without notice. TI grants you permission to use these resources only for development of an application that uses the TI products described in the resource. Other reproduction and display of these resources is prohibited. No license is granted to any other TI intellectual property right or to any third party intellectual property right. TI disclaims responsibility for, and you will fully indemnify TI and its representatives against, any claims, damages, costs, losses, and liabilities arising out of your use of these resources.

TI's products are provided subject to [TI's Terms of Sale](#) or other applicable terms available either on ti.com or provided in conjunction with such TI products. TI's provision of these resources does not expand or otherwise alter TI's applicable warranties or warranty disclaimers for TI products.

TI objects to and rejects any additional or different terms you may have proposed.

Mailing Address: Texas Instruments, Post Office Box 655303, Dallas, Texas 75265
Copyright © 2022, Texas Instruments Incorporated