

# **Pop Reduction for the TPA1517 Audio Power Amplifier**

*Mark Ginsberg**HPL/Audio Power Amplifiers*

## **ABSTRACT**

The [TPA1517](#) audio power amplifier is a powerful and versatile device that can deliver greater than 6 W of stereo power into loads as low as 4  $\Omega$ .

One phenomenon of the TPA1517, however, is the undesirable pop heard when the device comes out of standby mode. This application report is for circuit designers who wish to reduce this pop to lower levels.

This document can help circuit designers to better understand what pop is, why it occurs with this device, why the pop-reduction circuit works, and the tradeoffs that occur when different components are used in the circuit.

## **1 Introduction**

The pop heard when an audio amplifier comes in and out of shutdown or standby, or is simply powered on and off, can directly affect the enjoyment the listener experiences when they turn on the television, stereo, powered speakers, portable radio, or any other device that plays audio. Most of us know this phenomenon as the thud or crack heard when turning on the receiver at home, or the powered speakers for the computer. For most people, this is considered a minor nuisance at most, and eventually they ignore it. This usually occurs if the annoying sound is moderate to begin with.

In certain circumstances, the pop can be so loud as to cause irritation, agitation, and perhaps even physical discomfort to the ear.

Well-designed circuitry can either eliminate or greatly reduce the amount of pop that actually arrives at the speaker, and subsequently to the listener's ear. This application report provides that circuitry, as well as explanations and alternatives. Scope captures show just what the pop really is, and how the circuitry works to reduce or eliminate it. The impact of this particular pop solution on the total harmonic distortion plus noise vs output power and frequency are minimal, and sweeps taken with an Audio Precision™ analyzer are provided to demonstrate this.

## **2 What Causes Pop in the TPA1517?**

The pop addressed in this application report is the undesirable noise heard when the part is taken out of standby mode, as well as the power-up and power-down sequences (addressed in Section 5).

The pop heard when the device is put into standby mode is minimal, but the pop heard when the TPA1517 comes out of standby mode is significant. It is caused by two events happening simultaneously: the inputs biasing up to the proper level, and a change in the output bias level.

[Figure 1](#) and [Figure 2](#) are scope captures of what the typical noise pop looks like. A Texas Instruments evaluation module (EVM) was used with a 4- $\Omega$  load and a 12-V supply. Note the shape of the output traces, both before and after the output decoupling capacitor. The sharp transients are the same. Also note that the dc level of Trace 2 drops to 0 V for 40 ms to 50 ms before slowly rising back up to midrail.

[Figure 2](#) shows more detail at the time the device is brought from the standby state to the active state, but fails to demonstrate the long time necessary for the dc voltage to properly bias.

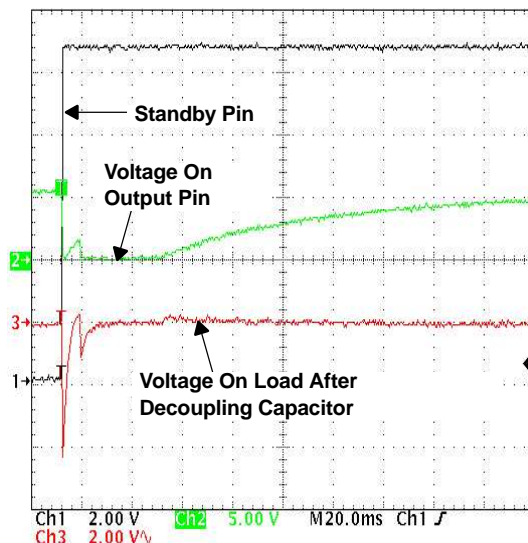

Figure 1. TPA1517 Pop With a 4-Ω Load and a 12-V Supply

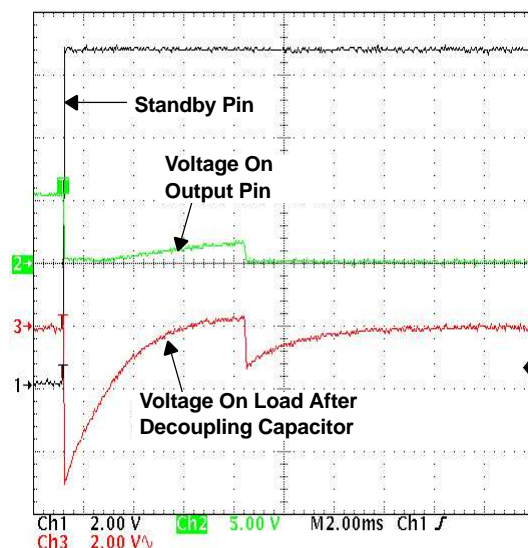

Figure 2. TPA1517 Pop With a 4-Ω Load and a 12-V Supply (Zoom In)

## 2.1 How the Input Bias Causes Pop

The dc bias at the input stage of the TPA1517 is nominally 2.1 V regardless of the supply voltage. When the TPA1517 is placed into standby mode, the input bias voltage drops, often by several hundred millivolts or more. When the device is returned to an active state, the input bias voltage quickly returns to its nominal level of 2.1 V. The farther away from 2.1 V the input bias voltage rests in standby, the louder the pop is when returning to an active state. Figure 3 graphically demonstrates what input noise pop looks like at the load in a 12-V, 4-Ω system. Trace 1 is the voltage on the STANDBY pin. Trace 2 is the voltage on the load side of the output decoupling capacitor, ac coupled.

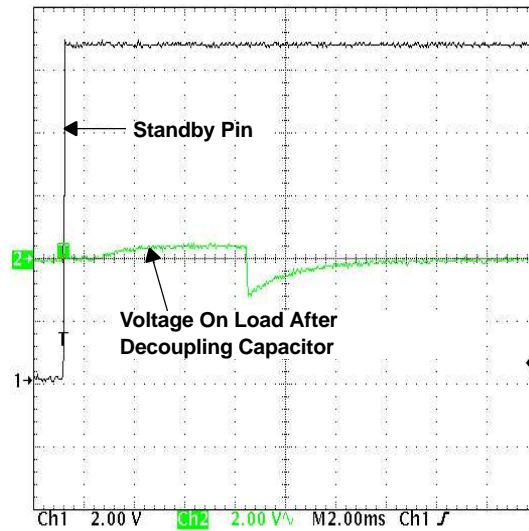

Figure 3. TPA1517 Pop Caused by the Inputs

## 2.2 How the Output Bias Causes Pop

The dc bias at the output stage of the TPA1517 is nominally  $V_{CC}/2$ . This is done so that the output signal can have a high output swing in both the positive and negative directions without one side being clipped before the other. Unlike many other TI Audio Power Amplifier devices, when the TPA1517 is placed into standby mode, the outputs do not go to ground. Rather, the outputs remain at dc midrail. However, during the transition from standby to active, the outputs can exhibit brief but sharp transient spikes in the dc voltage. These spikes, which can be several volts in magnitude, propagate to the speaker and cause the loud pop sound. This happens because the voltage variation is so quick that the dc-blocking capacitor fails to see this as a change in dc, and therefore allows the signal to pass through

Figure 4 is a scope capture of what the pop, caused by the output bias voltage, looks like at the load in a 12-V, 4- $\Omega$  system. Note the large voltage spike of approximately 5 V on both Traces 2 and 3.

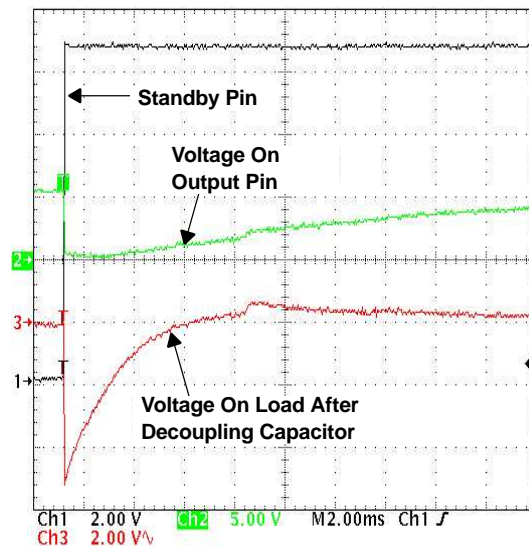

Figure 4. TPA1517 Pop Caused by the Outputs

### 3 Reducing the Pop

The pop is caused by dc bias issues at the input stage and output stage of the TPA1517. In order to minimize the pop as much as possible, it is necessary to find a solution to solve both the input and output bias problems. Essentially, this amounts to two separate solutions, because either one can be used individually.

#### 3.1 Quieting the Input Stage

The dc input bias problem does not contribute to the pop as much as the output dc bias, but it is more complicated and therefore is addressed first.

Because the pop generated by the input dc bias voltage is caused by the significant drop in the input dc bias voltage when the device goes into standby mode, the obvious solution is to force the inputs to 2.1 V, regardless of the state of the device.

This solution is not as simple as it first appears to be. Simply putting a resistor divider at the inputs to generate the 2.1 V (desired on the input pins) from the supply is not a good solution. Although it provides the constant dc bias required, it also requires that two resistors be permanently placed on the device-side of the input capacitor. This has the effect of greatly attenuating the input signal.

A solution is required in which the inputs are biased by an external source when the device is in standby mode, but where the external source is disconnected during normal operation. To accomplish this, a series of switches must be used with a resistor divider, sized appropriately for the supply voltage. The first switch is connected to the STANDBY pin and acts as an inverter. The second switch then serves to connect or disconnect the INPUT pin from the 2.1 V formed by the resistor divider.

The TPA1517 has a relatively large input bias current; so, it is necessary to use resistors of lower values in the resistor divider. This is so that the input bias current has as little effect as possible on the 2.1 V generated by the divider. Using resistors whose total series value is greater than 10 k $\Omega$  is unwise because the input bias current is large enough to significantly alter the divider voltage. However, to go too low in value results in high current through the resistors, and that can generate unwanted heat. For example, when R1 is 1 k $\Omega$  it dissipates about 100 mW and R2 about 25 mW with a divider current of 9.84 mA. If R1 is lowered to 100  $\Omega$ , instead of 1 k $\Omega$ , the divider current at 12 V jumps from 9.84 mA to 98.4 mA. That means that R1 is dissipating nearly 1 W of power and R2 nearly 1/4 W! See [Table 1](#) for the recommended resistor values for the input voltage divider. Exercise care in choosing resistors with the appropriate power ratings.

**Table 1. Recommended Resistor Values for the Input Voltage Divider**

V <sub>CC</sub>	R1	R2
10 V	1 k $\Omega$	270 $\Omega$
12 V	1 k $\Omega$	220 $\Omega$
14.5 V	1 k $\Omega$	180 $\Omega$
18 V	1 k $\Omega$	140 $\Omega$

#### 3.2 Quieting the Output Stage

The impact of the output transients on pop is enormous. As can be seen in [Figure 2](#), the output stages are responsible for the largest spike, which can easily be correlated with what the ear hears.

The solution to pop caused by the output stage is to quickly (but not instantaneously) pull the outputs to ground when the device goes into standby mode, then allow the outputs to return to midrail when the device returns to active mode.

When the outputs are intentionally brought to ground, they cannot fluctuate when the device first returns to active mode. The outputs return to their proper level and are able to drive speakers only when the output switch turns off (transistors Q2 and Q3 are output switches, see [Figure 5](#)).

### 3.3 Tying it all Together

Both the inputs and outputs must have the proper circuitry around them for the best pop solution. In addition, because the TPA1517 is a stereo amplifier, the pop-reduction circuitry must be adapted to work for both channels with a minimal component count. This can be accomplished by using just one inverter to drive both left and right input switches and both left and right output switches.

Figure 5 is a detailed schematic for a full stereo solution. The circuit depicted in Figure 5 uses bipolar transistors, which are generally less expensive than FETs. If FETs are preferred, a similar circuit is depicted in Figure 6. Standby Control should be pulled to ground for a low. This ensures that variations in  $V_{BE}$  do not accidentally activate the circuit.

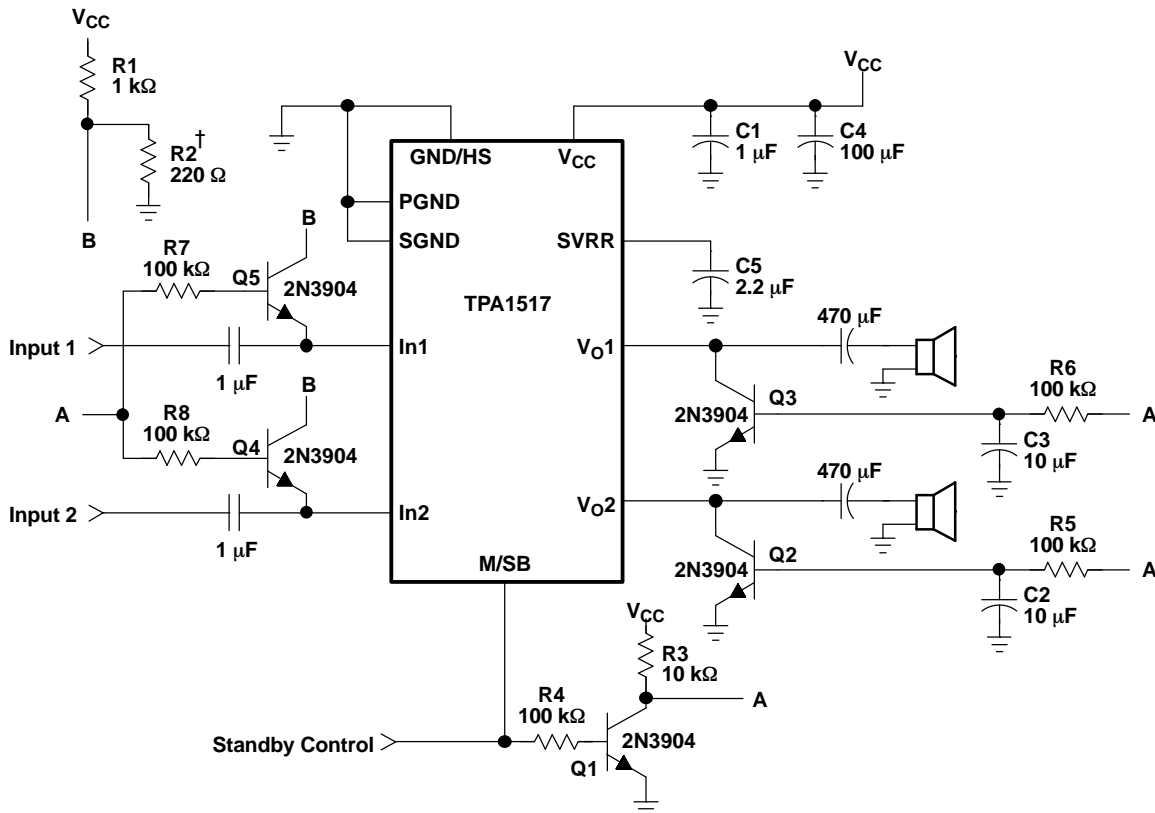

†See Table 1 for recommended R2 values for different  $V_{CC}$

Figure 5. Detailed Schematic for Full Stereo Solution Using Bipolar Transistors

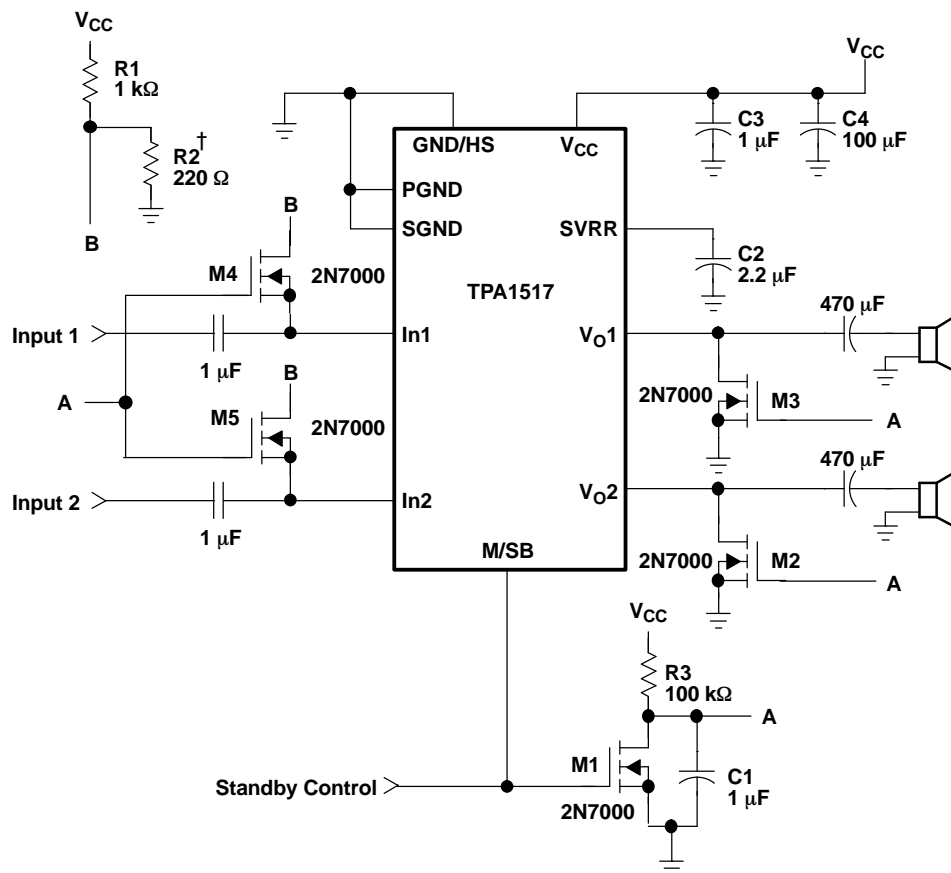

†See Table 1 for recommended R2 values for different  $V_{CC}$

**Figure 6. Detailed Schematic for Full Stereo Solution Using FETs**

#### 4 Audio Performance

The TPA1517 pop solution presented in this document does not add to the total harmonic distortion plus noise (THD + N) of the overall system. [Figure 7](#) and [Figure 8](#) each contain two THD + N sweeps taken with a TPA1517 EVM. [Figure 7](#) is a THD + N vs output power sweep, whereas [Figure 8](#) is a THD + N vs frequency sweep. The higher distortion at lower frequencies, exhibited in [Figure 8](#), is due to the high-pass filter formed by the input capacitor and input resistance.

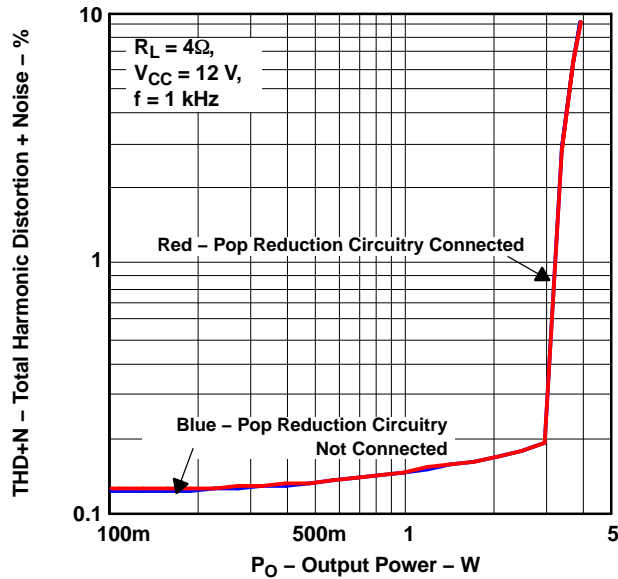

Figure 7. Comparison of THD+N vs  $P_O$  Sweeps

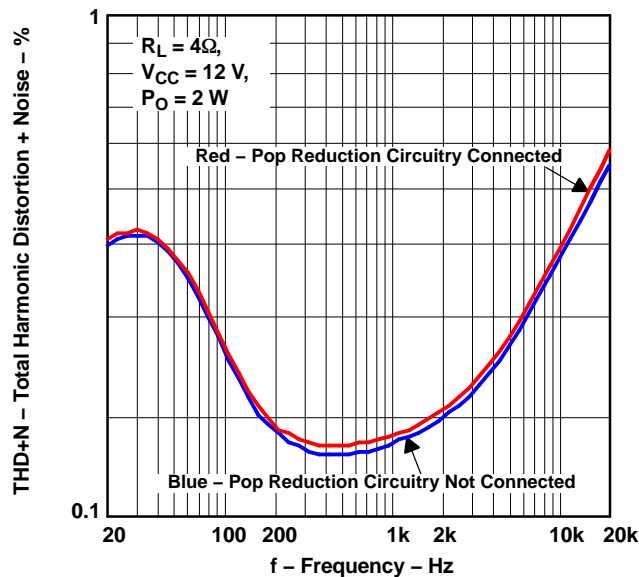

Figure 8. Comparison of THD+N vs Frequency Sweeps

## 5 Power-Up and Power-Down Pop Reduction

The pop reduction solution presented in this application report can also be used to lessen the effects of the power-up and power-down sequences.

During normal operation, the TPA1517 is subject to loud pops during power up and power down. The pop reduction circuitry can be easily adapted to overcome this annoyance as well. Left alone, the pop reduction circuitry does not help much during power up and power down because power is being removed

## *Trademarks*

---

from the pop-reducing circuitry as well as the device. However, the TPA1517 can be powered up and powered down in standby mode. Keeping the TPA1517 in standby mode while powering up gives the pop-reducing circuitry enough time to properly bias, so that when the device is placed into an active state the pop is greatly reduced. Likewise, the pop-reducing circuitry holds the output to ground when in standby mode, so that when the device is powered off, it is virtually popless.

## **6 Trademarks**

Audio Precision is a trademark of Audio Precision, Inc.



## IMPORTANT NOTICE

Texas Instruments Incorporated and its subsidiaries (TI) reserve the right to make corrections, modifications, enhancements, improvements, and other changes to its products and services at any time and to discontinue any product or service without notice. Customers should obtain the latest relevant information before placing orders and should verify that such information is current and complete. All products are sold subject to TI's terms and conditions of sale supplied at the time of order acknowledgment.

TI warrants performance of its hardware products to the specifications applicable at the time of sale in accordance with TI's standard warranty. Testing and other quality control techniques are used to the extent TI deems necessary to support this warranty. Except where mandated by government requirements, testing of all parameters of each product is not necessarily performed.

TI assumes no liability for applications assistance or customer product design. Customers are responsible for their products and applications using TI components. To minimize the risks associated with customer products and applications, customers should provide adequate design and operating safeguards.

TI does not warrant or represent that any license, either express or implied, is granted under any TI patent right, copyright, mask work right, or other TI intellectual property right relating to any combination, machine, or process in which TI products or services are used. Information published by TI regarding third-party products or services does not constitute a license from TI to use such products or services or a warranty or endorsement thereof. Use of such information may require a license from a third party under the patents or other intellectual property of the third party, or a license from TI under the patents or other intellectual property of TI.

Reproduction of information in TI data books or data sheets is permissible only if reproduction is without alteration and is accompanied by all associated warranties, conditions, limitations, and notices. Reproduction of this information with alteration is an unfair and deceptive business practice. TI is not responsible or liable for such altered documentation.

Resale of TI products or services with statements different from or beyond the parameters stated by TI for that product or service voids all express and any implied warranties for the associated TI product or service and is an unfair and deceptive business practice. TI is not responsible or liable for any such statements.

Following are URLs where you can obtain information on other Texas Instruments products and application solutions:

<b>Products</b>		<b>Applications</b>	
Amplifiers	<a href="http://amplifier.ti.com">amplifier.ti.com</a>	Audio	<a href="http://www.ti.com/audio">www.ti.com/audio</a>
Data Converters	<a href="http://dataconverter.ti.com">dataconverter.ti.com</a>	Automotive	<a href="http://www.ti.com/automotive">www.ti.com/automotive</a>
DSP	<a href="http://dsp.ti.com">dsp.ti.com</a>	Broadband	<a href="http://www.ti.com/broadband">www.ti.com/broadband</a>
Interface	<a href="http://interface.ti.com">interface.ti.com</a>	Digital Control	<a href="http://www.ti.com/digitalcontrol">www.ti.com/digitalcontrol</a>
Logic	<a href="http://logic.ti.com">logic.ti.com</a>	Military	<a href="http://www.ti.com/military">www.ti.com/military</a>
Power Mgmt	<a href="http://power.ti.com">power.ti.com</a>	Optical Networking	<a href="http://www.ti.com/opticalnetwork">www.ti.com/opticalnetwork</a>
Microcontrollers	<a href="http://microcontroller.ti.com">microcontroller.ti.com</a>	Security	<a href="http://www.ti.com/security">www.ti.com/security</a>
		Telephony	<a href="http://www.ti.com/telephony">www.ti.com/telephony</a>
		Video & Imaging	<a href="http://www.ti.com/video">www.ti.com/video</a>
		Wireless	<a href="http://www.ti.com/wireless">www.ti.com/wireless</a>

Mailing Address: Texas Instruments  
Post Office Box 655303 Dallas, Texas 75265