

Increase Traction Inverter System Robustness With a HV to LV Backup Supply

Jacob Vasquez

ABSTRACT

A redundant high-voltage to low-voltage backup power supply is becoming prevalent in automotive powertrain applications as the industry trends in the direction of increased safety. This application report discusses key considerations for the backup power supply such as the power device voltage rating, start-up circuitry, noise coupling, and safety.

Contents

1	Power Device Voltage Rating	3
2	Start-Up Circuitry.....	3
3	Noise Coupling	4
4	Safety.....	4
5	Summary	4
6	Related Documentation	5

Trademarks

All trademarks are the property of their respective owners.

Introduction

The traction inverter efficiently converts DC power from a high-voltage battery to alternating phases of power needed to drive multi-phase motors. Galvanic isolation is required to protect people, as well as the low-voltage components on the cold side of the system, from the high-voltage traction inverter on the hot side of the system. As automotive applications continue to trend in the direction of increased safety, it has become more common to include a high-voltage to low-voltage backup supply in the traction inverter system. The backup power supply powers the low-voltage components if the 12-V battery fails. Figure 1 displays an example block diagram featuring the high-voltage to low-voltage redundant power supply.

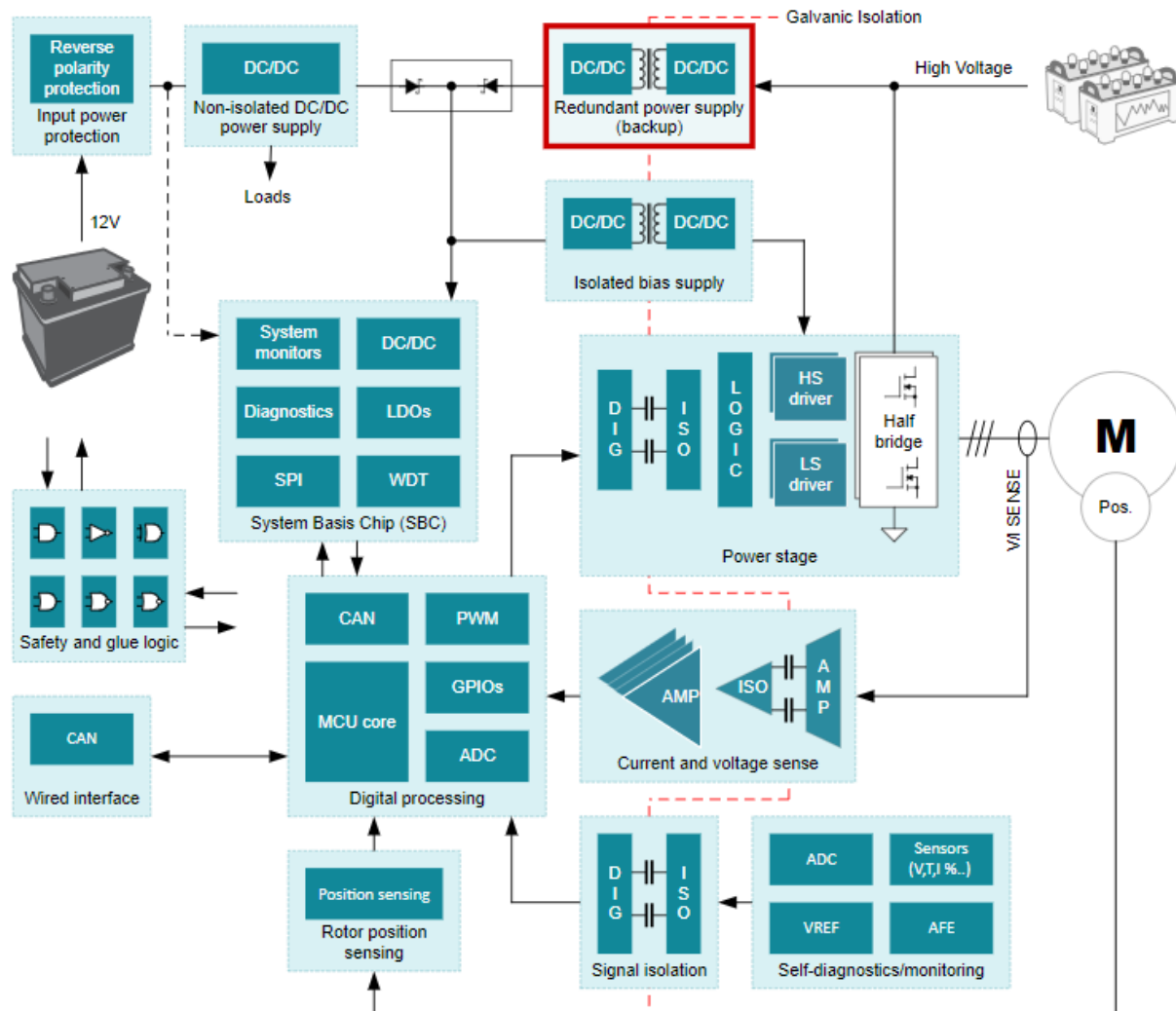

Figure 1. Traction Inverter Block Diagram

The flyback topology is the most popular redundant power supply solution due to a low cost, and the ability to support a wide input-voltage range. A flyback controller such as the [UCC28C42-Q1](#), or the [UCC28700-Q1](#), is suitable for this application.

The high-voltage to low-voltage backup supply presents new challenges compared to the low-input voltage flyback converters that currently dominate HEV and EV powertrain. The high-voltage input flyback converter needs to support ultra-wide input voltages. The backup supply may be required to operate down to 40 V to enable discharging the DC link capacitor to a safe voltage level in the case of a crash event. A 1 kV maximum input-voltage may be required in 800-V battery systems. Additional challenges, which arise from operating off the high-voltage battery, are selecting a high-voltage power device, minimizing start-up losses and noise coupling, and ensuring the system meets safety standards.

When designing a redundant, flyback power supply, the following design considerations need to be accounted for.

1 Power Device Voltage Rating

The maximum input voltage must be considered when selecting the power device. For 400-V battery systems, a Silicon MOSFET is typically used. For 800-V battery systems, Silicon Carbide (SiC) MOSFETs are becoming more popular due to their fast switching and high voltage rating (typically 900 V or greater).

The Silicon MOSFET driver integrated in the flyback controller may not be able to drive a SiC MOSFET directly. In these cases, external gate driver circuitry, or a low-side gate driver like the [UCC27531A-Q1](#), are recommended.

Careful consideration must be given to the UVLO turn-off threshold of the flyback controller. For SiC applications, a UVLO turn-off of greater than 8 V is recommended to provide increased lifetime reliability of the SiC MOSFET. Drive voltages less than 8 V can cause the power device to operate in the saturation region, which results in high conduction losses and heating. However, silicon MOSFETs can typically support drive voltages below 8 V.

2 Start-Up Circuitry

Standby power is a critical requirement in battery-operated systems. Resistive start-up circuitry causes high quiescent losses at high input voltages. Therefore, an external, active start-up circuit, or a device with integrated HV start-up such as the [UCC28730-Q1](#) or [UCC28740-Q1](#), is recommended.

[Figure 2](#) shows how an external, active start-up circuit can be implemented for a controller that utilizes resistive start-up, such as the [UCC28C42-Q1](#). Detailed design calculations for external, active start-up circuitry can be found in section 2.3.8 of [TIDA-01505](#).

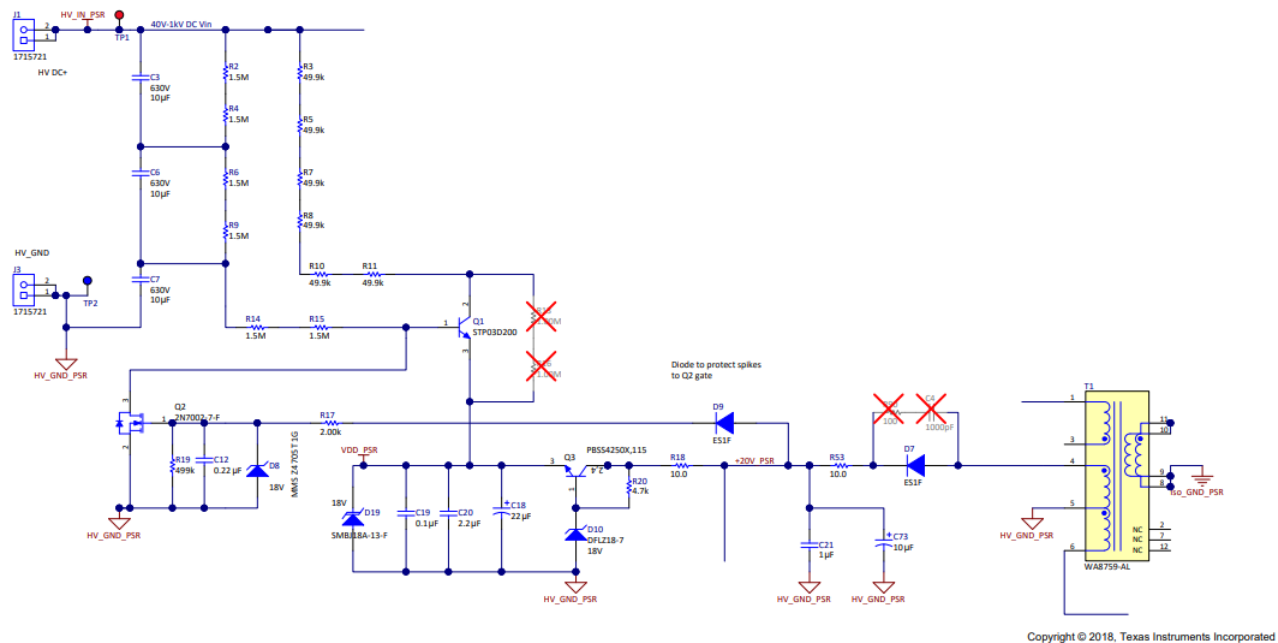

Figure 2. Active Start-Up Circuit

The [UCC28730-Q1](#) and [UCC28740-Q1](#) offer integrated 700-V start up, which enables operation directly off of a 400-V battery, but not an 800-V battery. As shown in [Figure 3](#), powering the start-up circuit from the center point of a stacked capacitor bank, or using a clamp circuit to clamp the voltage, enables operation directly off of an 800-V battery.

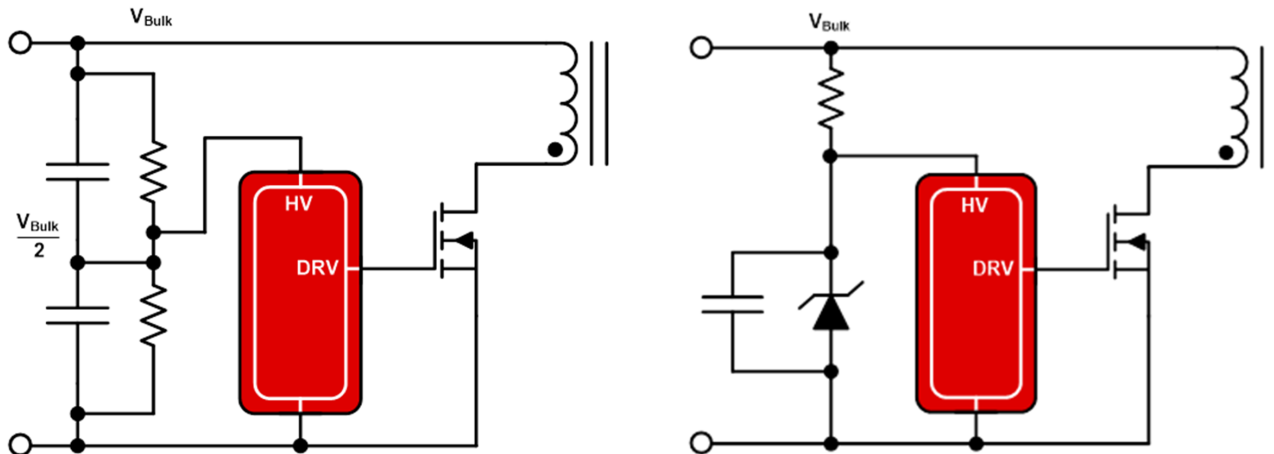

Figure 3. Implementation to Support > 700 V Inputs

The [UCC28700-Q1](#), and [UCC28730-Q1](#) and [UCC28740-Q1](#) variable frequency, peak current-mode flyback controllers and the [UCC28C42-Q1](#) fixed-frequency, peak current-mode PWM controller offer a wide UVLO hysteresis that allows for more headroom on the VDD voltage before triggering UVLO, which provides long soft-start times and requires less capacitance on the VDD pin.

3 Noise Coupling

The high-voltage input and fast switching of the power device can lead to a high dv/dt switching node, which generates a large amount of noise.

When designing the backup flyback converter, it is critical to consider the voltage rating for the current sense pin. A higher current-sense voltage rating provides robustness against false CS pin triggering when operating across an ultra-wide input voltage range, and in a noisy environment.

The high dv/dt nodes must be kept small and away from quiet areas, such as the current sense circuitry, to reduce noise coupling.

4 Safety

The distance between the high-voltage area at the primary side, and low-voltage area at the secondary side, must have enough clearance to comply with standards such as IEC 60664-1.

The ground of the low-voltage side can be connected to a 12-V battery or vehicle chassis, which a user can come in contact with. Therefore, a transformer with reinforced isolation and AEC-Q200 Grade 1 compliance is recommended for this application.

The primary-side regulated flyback solutions, [UCC28700-Q1](#) and [UCC28730-Q1](#), do not require an optocoupler for feedback. This eliminates a component crossing the isolation barrier, and provides a more cost-effective solution. [UCC28C42-Q1](#) can be configured as a primary-side regulated solution by using an auxiliary winding for feedback.

5 Summary

When designing a HV flyback supply, careful consideration is required for selecting a high voltage power device, minimizing standby power losses and noise coupling, and ensuring the system meets safety requirements. For high voltage power device selection, Silicon MOSFETs are typically acceptable for 400V systems. However, Silicon Carbide MOSFETs are typically used in 800V systems due to their higher voltage rating (typically 900V or greater). External or internal start-up circuitry can be used to minimize standby power consumption. A high current sense voltage rating provides additional robustness against false CS pin triggering in a noisy environment. Primary-side regulated feedback does not require an optocoupler which increases system reliability and eliminates a component crossing the isolation barrier.

The reference design of the [TIDA-01505](#) 40-V to 1-kV input HV to LV redundant power supply provides an in-depth overview of addressing these design requirements. The [PMP10200](#) 25-520 V_{in} flyback reference design also illustrates a potential solution for this application. The PMP10200 reference design supports a wide input voltage range, but does not need to supply full power at the minimum input voltage. [Table 1](#) covers the differences between TI's automotive flyback solutions.

6 Related Documentation

- Texas Instruments, [Automotive 40V to 1kV input flyback reference design supporting regenerative braking test](#)
- Texas Instruments, [Ultra-Wide Input Voltage Range PSR Flyback Converter Reference Design](#)
- Texas Instruments, [Why is high UVLO important for safe IGBT and SiC MOSFET power switch operation?](#)

Table 1. Flyback Controller Family Highlights

DEVICE	REGULATION	OPERATION MODE	CONTROL LAW	INTERNAL HIGH-VOLTAGE START UP	UVLO ON/OFF THRESHOLD (typ)	MAX CURRENT SENSE THRESHOLD (typ)	PACKAGE
UCC28C42-Q1	PSR or SSR ^{(1), (2)}	DCM or CCM ^{(3), (4)}	Fixed-Frequency PWM	No	14.5 V / 9 V	1 V	SOIC-8
UCC28700-Q1	PSR ⁽¹⁾	DCM ⁽³⁾	AMFM ⁽⁵⁾	No	21 V / 8 V	0.75 V	SOT23-6
UCC28730-Q1	PSR ⁽¹⁾	DCM ⁽³⁾	AMFM ⁽⁵⁾	Yes	21 V / 7 V	0.74 V	SOIC-7
UCC28740-Q1	SSR ⁽²⁾	DCM ⁽³⁾	AMFM ⁽⁵⁾	Yes	21 V / 7.75 V	0.773 V	SOIC-7

- (1) PSR = Primary side regulation
 (2) SSR = Secondary side regulation
 (3) DCM = Discontinuous conduction mode
 (4) CCM = Continuous conduction mode
 (5) AMFM = Amplitude Modulation/Frequency Modulation

IMPORTANT NOTICE AND DISCLAIMER

TI PROVIDES TECHNICAL AND RELIABILITY DATA (INCLUDING DATASHEETS), DESIGN RESOURCES (INCLUDING REFERENCE DESIGNS), APPLICATION OR OTHER DESIGN ADVICE, WEB TOOLS, SAFETY INFORMATION, AND OTHER RESOURCES "AS IS" AND WITH ALL FAULTS, AND DISCLAIMS ALL WARRANTIES, EXPRESS AND IMPLIED, INCLUDING WITHOUT LIMITATION ANY IMPLIED WARRANTIES OF MERCHANTABILITY, FITNESS FOR A PARTICULAR PURPOSE OR NON-INFRINGEMENT OF THIRD PARTY INTELLECTUAL PROPERTY RIGHTS.

These resources are intended for skilled developers designing with TI products. You are solely responsible for (1) selecting the appropriate TI products for your application, (2) designing, validating and testing your application, and (3) ensuring your application meets applicable standards, and any other safety, security, or other requirements. These resources are subject to change without notice. TI grants you permission to use these resources only for development of an application that uses the TI products described in the resource. Other reproduction and display of these resources is prohibited. No license is granted to any other TI intellectual property right or to any third party intellectual property right. TI disclaims responsibility for, and you will fully indemnify TI and its representatives against, any claims, damages, costs, losses, and liabilities arising out of your use of these resources.

TI's products are provided subject to TI's Terms of Sale (www.ti.com/legal/termsofsale.html) or other applicable terms available either on ti.com or provided in conjunction with such TI products. TI's provision of these resources does not expand or otherwise alter TI's applicable warranties or warranty disclaimers for TI products.

Mailing Address: Texas Instruments, Post Office Box 655303, Dallas, Texas 75265
Copyright © 2019, Texas Instruments Incorporated