

Designing Ultrafast Loop Response With Type-III Compensation for Current Mode Step-Down Converters

Ning Tang

Power Management

ABSTRACT

One of the well-known benefits of current-mode control is that the system stability can be easily achieved by Type-II compensation design. It is possible to improve the transient response of a current mode DC/DC converter by adopting Type-III compensation to boost the crossover frequency and phase margin. Type-III compensation is simple to design and needs only one extra component.

This application report shows a general, step-by-step, Type-III compensation design procedure for current-mode, step-down DC/DC converters as well as a design example using the TPS54620 from the SWIFT™ converter product portfolio.

To simplify design efforts, a complementary design calculator ([SLVC219](#)) is available.

Contents

1	Introduction	2
2	Basic of Compensation Networks	3
3	Design Procedure for Current-Mode Type-III Compensation Networks	4
4	System Performances for Example Design	6
5	Limitations for Current-Mode Type-III Compensation Design Procedure	7
6	Conclusion	8

List of Figures

1	TPS54620EVM-374 Schematic (Fsw = 480 kHz)	2
2	Measured Loop Response for TPS54620EVM-374	2
3	Type-II Compensation Networks	3
4	Type-III Compensation Networks	3
5	Example Design With Type-III Compensation (Fsw = 480 kHz)	6
6	Measured Loop Response for Example Design	6
7	Example Design Transient Response	7
8	TPS54620EVM-374 Transient Response	7
9	Maximum Phase Boost From Type-III Compensation	7

List of Tables

1	Frequency Responses and Simplified Pole/Zero Locations	3
2	TPS54620EVM-374 Design Parameters	4

1 Introduction

The latest generation of SWIFT™ DC/DC converters such as the TPS54418 and TPS54620 families have implemented current-mode control to simplify the external compensation design. Figure 1 from *TPS54620EVM-374 6-A, SWIFT™ Regulator Evaluation Module user's guide (SLVU281)* shows a typical current-mode design schematic. Figure 2 shows the measured loop-response characteristics at $V_{in} = 12\text{ V}$ and $V_{out} = 3.3\text{ V}/6\text{ A}$.

The resistor R4 and capacitor C4 in Figure 1 determine a typical Type-II compensation network. The overall system is stable with 45-kHz crossover frequency and 46° phase margin. For a general-purpose DC/DC converter, 45-kHz crossover frequency is adequate. In some applications, ultrafast transient response may be required and 100-kHz crossover frequency or higher may be desired. Because the power-stage phase response can drop fast at high frequencies, it is usually difficult to maintain adequate phase margin using Type-II compensation. A Type-III compensation network can be selected as an alternative.

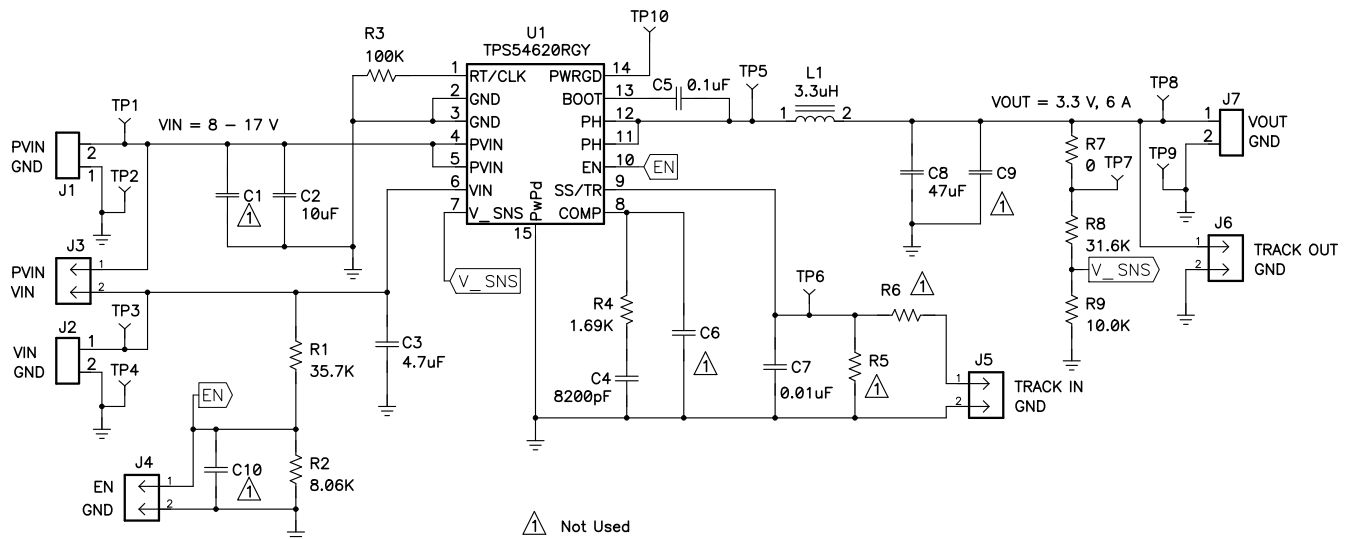

Figure 1. TPS54620EVM-374 Schematic (Fsw = 480 kHz)

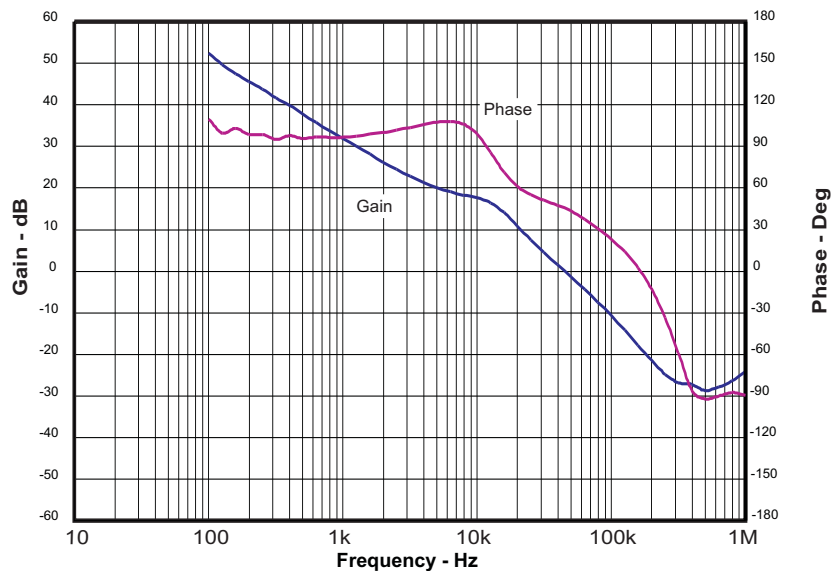

Figure 2. Measured Loop Response for TPS54620EVM-374

SWIFT is a trademark of Texas Instruments.

2 Basic of Compensation Networks

Figure 3 and Figure 4 show commonly used Type-II and Type-III compensation networks. The difference between the Type-2A/2B and the Type-3A/3B circuits is that the Type-2A/3A circuits include an additional high-frequency pole which has been added to attenuate high-frequency noise, when necessary.

The only difference between the Type-2A/2B and Type-3A/3B circuits is the capacitor Cc. This capacitor generates one more zero around the desired crossover frequency, and forms one very-high-frequency pole in the system which is normally ignorable.

Roea and Coea are the equivalent output resistance and output capacitance respectively for the gm error amplifier. The equation for Roea calculation is shown in Table 1. Coea is usually small and can be neglected.

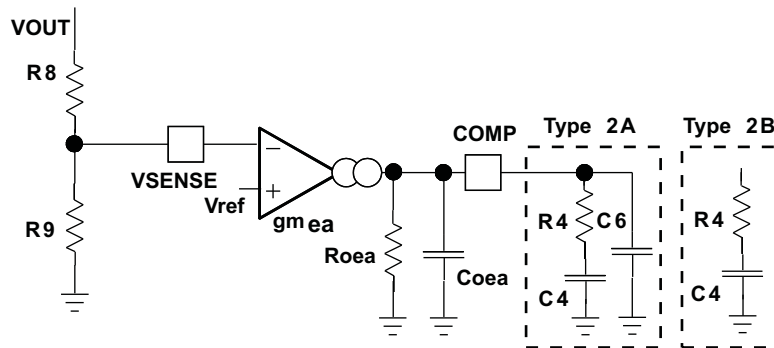

Figure 3. Type-II Compensation Networks

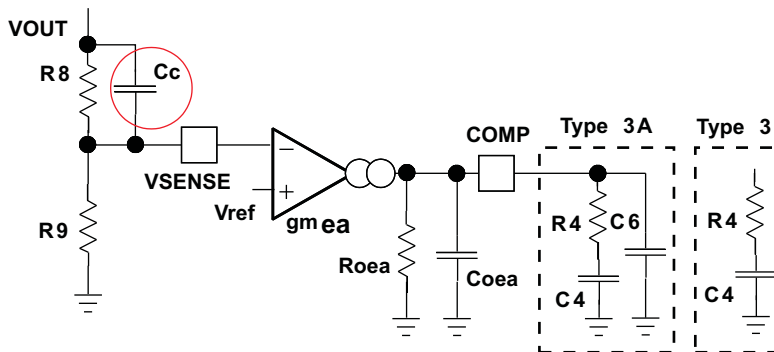

Figure 4. Type-III Compensation Networks

Table 1 provides the frequency responses and simplified pole/zero locations for the compensation networks shown in Figure 3 and Figure 4.

Table 1. Frequency Responses and Simplified Pole/Zero Locations

Compensation	Frequency Responses	Pole/Zero Locations
Type 2A		$f_{p1} = \frac{1}{2\pi \times R_{oea} \times C_4}$ $f_{z2} = \frac{1}{2\pi \times R_4 \times C_4}$ $f_{p3} = \frac{1}{2\pi \times R_4 \times C_6}$

Table 1. Frequency Responses and Simplified Pole/Zero Locations (continued)

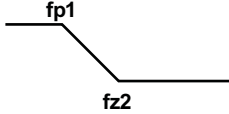
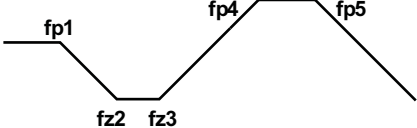
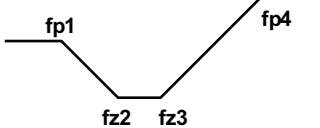
Compensation	Frequency Responses	Pole/Zero Locations
Type 2B		$f_p 1 = \frac{1}{2\pi \times R_{oea} \times C_4}$ $f_z 2 = \frac{1}{2\pi \times R_4 \times C_4}$
Type 3A		$f_p 1 = \frac{1}{2\pi \times R_{oea} \times C_4}$ $f_z 2 = \frac{1}{2\pi \times R_4 \times C_4}$ $f_z 3 = \frac{1}{2\pi \times R_8 \times C_c}$ $f_p 4 = \frac{1}{2\pi \times (R_8 // R_9) \times C_c}$ $f_p 5 = \frac{1}{2\pi \times R_4 \times C_6}$
Type 3B		$f_p 1 = \frac{1}{2\pi \times R_{oea} \times C_4}$ $f_z 2 = \frac{1}{2\pi \times R_4 \times C_4}$ $f_p 3 = \frac{1}{2\pi \times R_8 \times C_c}$ $f_p 4 = \frac{1}{2\pi \times (R_8 // R_9) \times C_c}$
Where $R_{oea} = \frac{DCgain_{ea}}{gm_{ea}}$, $R_8 // R_9 = \frac{R_8 \times R_9}{R_8 + R_9}$		

3 Design Procedure for Current-Mode Type-III Compensation Networks

Using the same design parameters for [Figure 1](#), this section presents the general design procedure for Type-III compensation networks.

1. Design the power stage of the switching regulator. In this example, a 3.3- μ H inductor and two 100- μ F, 6.3-V ceramic capacitors are selected as the output inductor and output capacitors, respectively. See the corresponding data sheet ([SLVS949](#)) and design calculator ([SLVC219](#)) for the details.

Table 2. TPS54620EVM-374 Design Parameters

Parameter	Value
Output voltage (VOUT)	3.3 V
Output current (IOUT)	6 A
Input voltage (VIN)	12 V nominal, 8 V to 17 V
Switching frequency (Fsw)	480 kHz

2. Determine the crossover frequency f_c . It is suggested to choose f_c between 70kHz and 130kHz. Generally speaking, the desired f_c should be lower for lower output voltage applications because the limited phase boost available from the Type-III compensation network. For details, see [Section 5](#). In this case, f_c is selected to be 120 kHz.
3. R4 can be determined by

$$R4 = \frac{2\pi \times f_c \times V_{OUT} \times C_o}{g_{m_{ea}} \times V_{ref} \times g_{m_{ps}}} = \frac{2\pi \times 120\text{kHz} \times 3.3\text{V} \times (47.6\mu\text{F} \times 2)}{1300\mu\text{A/V} \times 0.8\text{V} \times 16\text{A/V}} = 14.2\text{k}\Omega \approx 14.3\text{k}\Omega \quad (1)$$

Where:

$g_{m_{ea}}$ – the GM amplifier gain (1300 $\mu\text{A/V}$)
 $g_{m_{ps}}$ – the power stage gain (16 A/V).
 V_{ref} – the reference voltage (0.8 V)

In Equation 1, the actual output equivalent capacitance must be used. For ceramic output capacitors, the actual capacitance has to be properly derated according to the applied DC voltage. A simplified derating equation for standard ceramic output capacitor is shown in Equation 2. For more accurate derating models, refer to the manufacturer data sheets for the output capacitors being used.

$$C_{o,actual} = C_{o,nominal} \times \frac{V_{rating} - V_{dc}}{V_{rating}} = 100\mu\text{F} \times \frac{6.3\text{V} - 3.3\text{V}}{6.3\text{V}} = 47.6\mu\text{F} \quad (2)$$

Where:

V_{rating} – the voltage rating of the ceramic capacitor
 V_{dc} – the applied DC voltage of the ceramic capacitor

4. Place a compensation zero at the dominant pole f_p . $\left(f_p = \frac{1}{C_o \times R_L \times 2\pi} \right)$

$C4$ can be determined by:

$$C4 = \frac{R_L \times C_o}{R4} = \frac{V_{OUT} \times C_o}{I_{OUT} \times R4} = \frac{3.3\text{V} \times (47.6\mu\text{F} \times 2)}{6\text{A} \times 14.3\text{k}\Omega} = 3.67\text{nF} \approx 3.9\text{nF} \quad (3)$$

5. $C6$ is optional. It can be used to cancel the zero from the ESR (Equivalent Series Resistance) of the output capacitor C_o .

$$C6 = \frac{R_{ESR} \times C_o}{R4} \quad (4)$$

$C6$ is usually only needed when the ESR zero is less than half of the switching frequency.

$$f_{esr} = \frac{1}{2\pi \times R_{ESR} \times C_o} = \frac{1}{2\pi \times 2\text{m}\Omega \times (47.6\mu\text{F} \times 2)} = 836.3\text{kHz} \quad (5)$$

In this case, the ESR zero is located at 836.3 kHz, which is greater than $F_{sw}/2 = 240\text{kHz}$. So, $C6$ is not used. $C6$ is usually not needed for ceramic output capacitors.

6. C_c is selected to provide a zero around the desired crossover frequency (f_c) with $R8$. When using Type-III compensation design, it is convenient to fix $R8$ value at 10 k Ω and vary $R9$ to set the output voltage V_{OUT} .

$$C_c = \frac{1}{2\pi \times R8 \times f_c} = \frac{1}{2\pi \times 10\text{k}\Omega \times 120\text{kHz}} = 132.7\text{pF} \approx 150\text{pF} \quad (6)$$

The complete example design with Type-III compensation is shown in Figure 5.

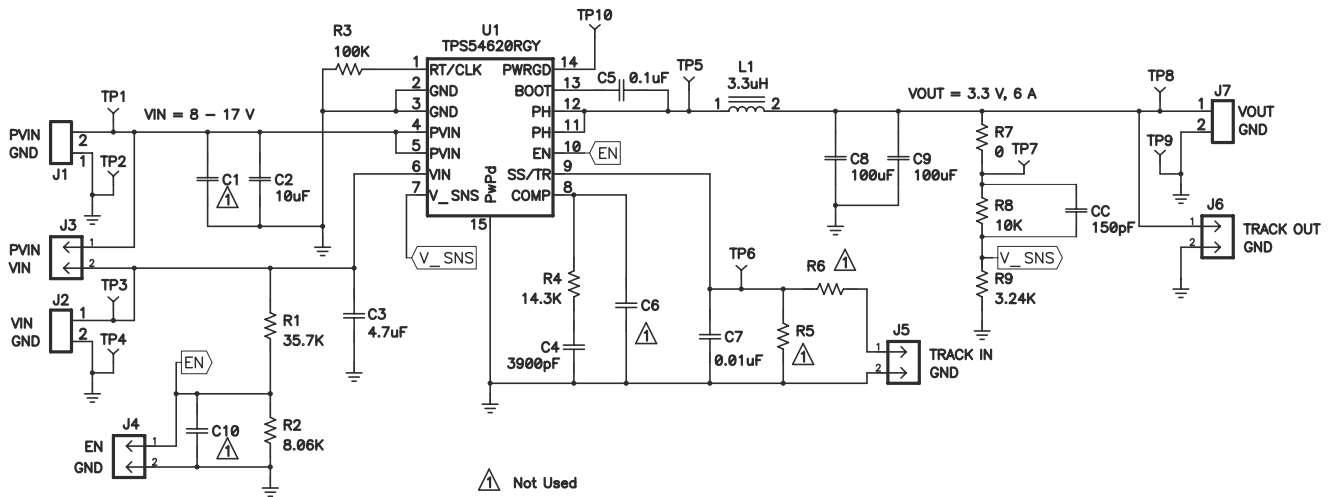

Figure 5. Example Design With Type-III Compensation (Fsw = 480 kHz)

4 System Performances for Example Design

Figure 6 shows the loop-response characteristics. Gain and phase plots are shown for Vin = 12 V and Vout = 3.3 V/6 A. The crossover frequency and phase margin are measured at 112 kHz and 60°, respectively.

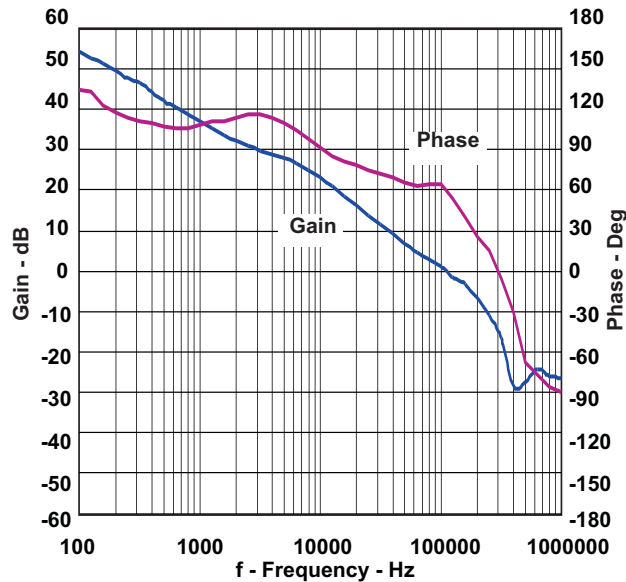

Figure 6. Measured Loop Response for Example Design

Figure 7 shows the response to load transients. The current step is from 25% to 75% of maximum-rated load at VIN = 12 V. Total peak-to-peak voltage variation is as shown, including ripple and noise on the output. Figure 8 shows the transient response for the TPS54620EVM-374 under the same condition. Comparing Figure 7 and Figure 8, the total peak-to-peak voltage variation has been dropped from 50 mV to 25 mV.

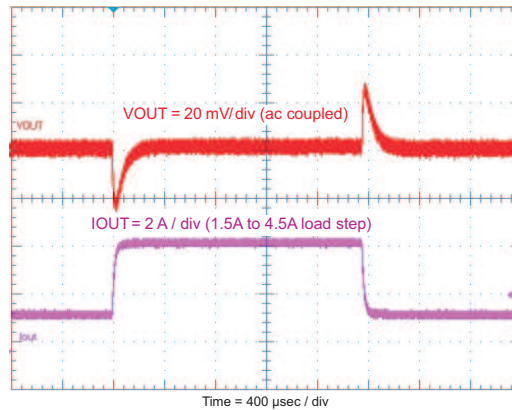

Figure 7. Example Design Transient Response

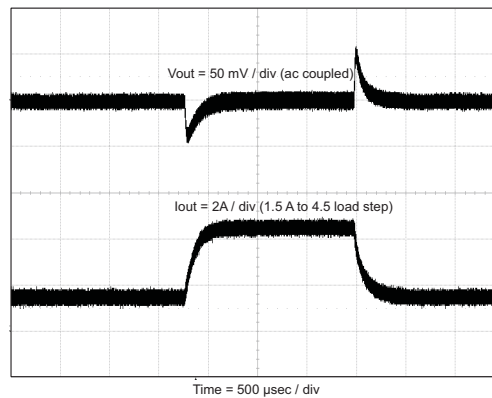

Figure 8. TPS54620EVM-374 Transient Response

5 Limitations for Current-Mode Type-III Compensation Design Procedure

The design procedure described uses simplified equations. It provides starting parameter values for a design. Sometimes, these values may have to be modified to yield the best results.

The Type-III compensation is usually able to boost the system bandwidth above 100 kHz with good phase margin. As the output voltage decreases, the phase boost from Type-III compensation is also reduced. Depending on the application requirements, the improvements on the crossover frequency and phase margin by the Type-III compensation may be limited at low output voltages. Figure 9 provides guidelines on the maximum phase boost that can be obtained from Type-III compensation for popular output voltage range.

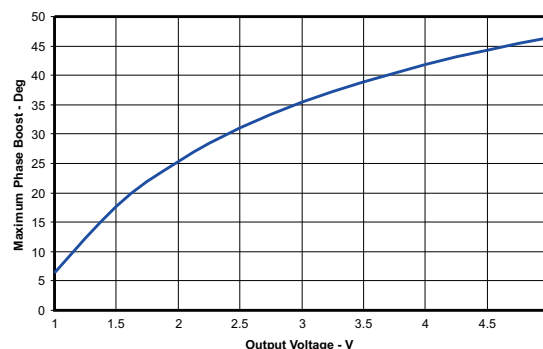

Figure 9. Maximum Phase Boost From Type-III Compensation

6 Conclusion

This application report shows an easy way to do Type-III compensation designs for current-mode, step-down DC/DC converters. The experimental measurements also illustrate the improvements of system bandwidth and transient responses by Type-III compensation design.

IMPORTANT NOTICE

Texas Instruments Incorporated and its subsidiaries (TI) reserve the right to make corrections, enhancements, improvements and other changes to its semiconductor products and services per JESD46, latest issue, and to discontinue any product or service per JESD48, latest issue. Buyers should obtain the latest relevant information before placing orders and should verify that such information is current and complete. All semiconductor products (also referred to herein as "components") are sold subject to TI's terms and conditions of sale supplied at the time of order acknowledgment.

TI warrants performance of its components to the specifications applicable at the time of sale, in accordance with the warranty in TI's terms and conditions of sale of semiconductor products. Testing and other quality control techniques are used to the extent TI deems necessary to support this warranty. Except where mandated by applicable law, testing of all parameters of each component is not necessarily performed.

TI assumes no liability for applications assistance or the design of Buyers' products. Buyers are responsible for their products and applications using TI components. To minimize the risks associated with Buyers' products and applications, Buyers should provide adequate design and operating safeguards.

TI does not warrant or represent that any license, either express or implied, is granted under any patent right, copyright, mask work right, or other intellectual property right relating to any combination, machine, or process in which TI components or services are used. Information published by TI regarding third-party products or services does not constitute a license to use such products or services or a warranty or endorsement thereof. Use of such information may require a license from a third party under the patents or other intellectual property of the third party, or a license from TI under the patents or other intellectual property of TI.

Reproduction of significant portions of TI information in TI data books or data sheets is permissible only if reproduction is without alteration and is accompanied by all associated warranties, conditions, limitations, and notices. TI is not responsible or liable for such altered documentation. Information of third parties may be subject to additional restrictions.

Resale of TI components or services with statements different from or beyond the parameters stated by TI for that component or service voids all express and any implied warranties for the associated TI component or service and is an unfair and deceptive business practice. TI is not responsible or liable for any such statements.

Buyer acknowledges and agrees that it is solely responsible for compliance with all legal, regulatory and safety-related requirements concerning its products, and any use of TI components in its applications, notwithstanding any applications-related information or support that may be provided by TI. Buyer represents and agrees that it has all the necessary expertise to create and implement safeguards which anticipate dangerous consequences of failures, monitor failures and their consequences, lessen the likelihood of failures that might cause harm and take appropriate remedial actions. Buyer will fully indemnify TI and its representatives against any damages arising out of the use of any TI components in safety-critical applications.

In some cases, TI components may be promoted specifically to facilitate safety-related applications. With such components, TI's goal is to help enable customers to design and create their own end-product solutions that meet applicable functional safety standards and requirements. Nonetheless, such components are subject to these terms.

No TI components are authorized for use in FDA Class III (or similar life-critical medical equipment) unless authorized officers of the parties have executed a special agreement specifically governing such use.

Only those TI components which TI has specifically designated as military grade or "enhanced plastic" are designed and intended for use in military/aerospace applications or environments. Buyer acknowledges and agrees that any military or aerospace use of TI components which have **not** been so designated is solely at the Buyer's risk, and that Buyer is solely responsible for compliance with all legal and regulatory requirements in connection with such use.

TI has specifically designated certain components as meeting ISO/TS16949 requirements, mainly for automotive use. In any case of use of non-designated products, TI will not be responsible for any failure to meet ISO/TS16949.

Products

Audio	www.ti.com/audio
Amplifiers	amplifier.ti.com
Data Converters	dataconverter.ti.com
DLP® Products	www.dlp.com
DSP	dsp.ti.com
Clocks and Timers	www.ti.com/clocks
Interface	interface.ti.com
Logic	logic.ti.com
Power Mgmt	power.ti.com
Microcontrollers	microcontroller.ti.com
RFID	www.ti-rfid.com
OMAP Applications Processors	www.ti.com/omap
Wireless Connectivity	www.ti.com/wirelessconnectivity

Applications

Automotive and Transportation	www.ti.com/automotive
Communications and Telecom	www.ti.com/communications
Computers and Peripherals	www.ti.com/computers
Consumer Electronics	www.ti.com/consumer-apps
Energy and Lighting	www.ti.com/energy
Industrial	www.ti.com/industrial
Medical	www.ti.com/medical
Security	www.ti.com/security
Space, Avionics and Defense	www.ti.com/space-avionics-defense
Video and Imaging	www.ti.com/video

TI E2E Community

e2e.ti.com