

# **Passing CISPR25-Radiated Emissions Using TPS54160-Q1**

Mahmoud Harmouch  
Todd Toporski

MSA-ASI  
Analog FAE

## **ABSTRACT**

This application report provides a summary of CISPR25-Radiated Emissions test results using the TPS54160-Q1 high-frequency buck converter. Similar results can be achieved using other devices in this family. This family of buck converters is capable of passing CISPR25 and other automotive electromagnetic-compatibility (EMC) test specifications. The TPS54160 family of devices does not require the use of programmable slew rate or frequency modulation. These devices can pass EMC tests by optimizing external components selection, placement, and board layout.

### **Contents**

1	Schematics and Printed Circuit Board (PCB) Description .....	2
	1.1 Schematics for PMP6990 .....	2
	1.2 Bill of Materials for PMP6990 .....	3
	1.3 PCB Layout .....	4
	1.4 R-C Snubber Added From PH to GND .....	6
2	Description and Setup for Radiated Emissions Measurements .....	7
	2.1 Setup Conditions .....	7
	2.2 Test Results .....	8
3	Summary .....	9

### **List of Figures**

1	PMP6990 Schematic .....	2
2	Top Assembly .....	4
3	Top-Layer Silkscreen and Routing .....	4
4	Layer 2 Routing .....	4
5	Layer 3 Routing .....	4
6	Bottom-Layer Silkscreen and Routing .....	4
7	With Snubber Added .....	6
8	Test Setup .....	7
9	CISPR25 Bicon Horizontal Results No R-C Snubber .....	8
10	CISPR25 Bicon Horizontal Results With R-C Snubber .....	8
11	CISPR25 Bicon Vertical Results No R-C Snubber .....	8
12	CISPR25 Bicon Vertical Results With R-C Snubber .....	8

### **List of Tables**

1	PMP6990 BOM .....	3
2	Comparison of Results, With and Without R-C Snubber .....	9

## 1 Schematics and Printed Circuit Board (PCB) Description

PMP6990 EMC reference board was designed for passing EMC as required by automotive specification CISPR25. PMP6990 Revision-A printed-circuit board (PCB) was used for all testing. Devices that can be tested on this board include:

- **Non-automotive:** TPS54040, TPS54060, TPS54140, TPS54160, TPS54240, TPS54260
- **Automotive:** TPS57040-Q1, TPS57060-Q1, TPS57140-Q1, TPS57160-Q1, TPS54140-Q1, TPS54160-Q1, TPS54240-Q1, TPS54260-Q1

### 1.1 Schematics for PMP6990

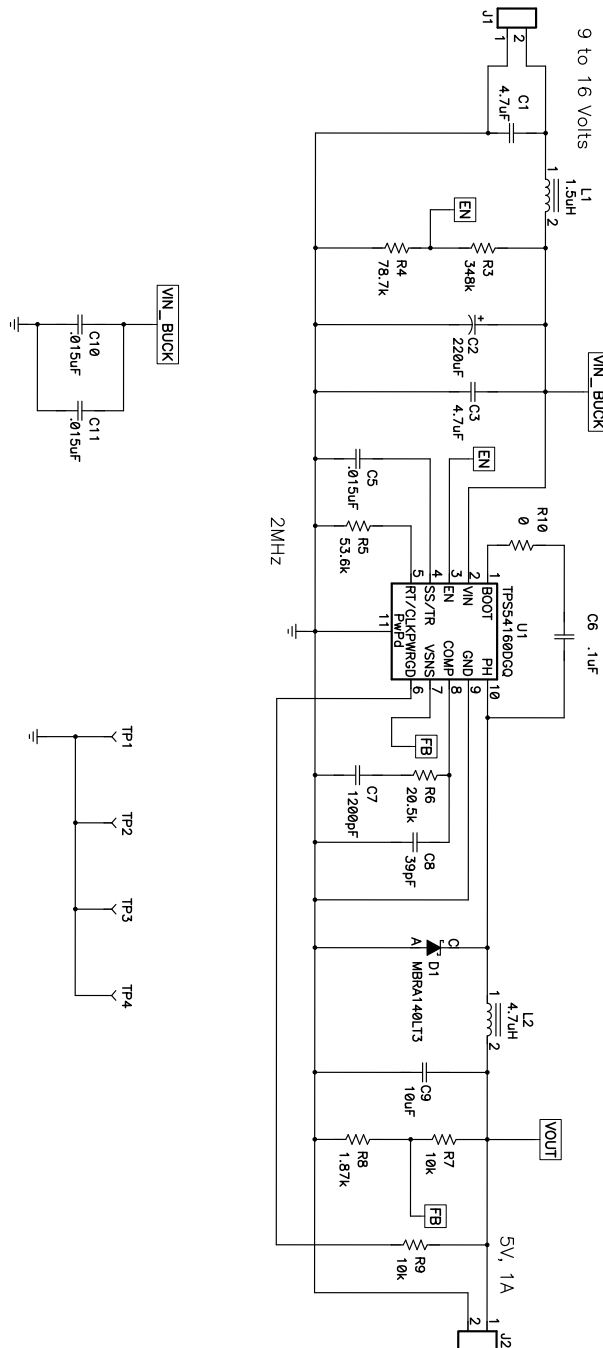


Figure 1. PMP6990 Schematic

## 1.2 Bill of Materials for PMP6990

**Table 1. PMP6990 BOM**

Designator	Quantity	Value	Description	Size and Package	Part Number	Manufacturer
C5	3	0.015 $\mu$ F	Capacitor, ceramic, 50-V, X7R, 10%	603	C1608X7R1H153K	TDK
C10		0.015 $\mu$ F	Capacitor, ceramic, 50-V, X7R, 10%	603	C1608X7R1H153K	TDK
C11		0.015 $\mu$ F	Capacitor, ceramic, 50-V, X7R, 10%	603	C1608X7R1H153K	TDK
C6	1	0.1 $\mu$ F	Capacitor, ceramic, 50-V, X7R, 10%	603	C1608X7R1H104K	TDK
C12	1	1.5 nF	Capacitor, ceramic, 50-V, X7R, 10%	603	C1608X7R1H153K	TDK
C8	1	39 pF	Capacitor, ceramic, 50-V, COG, 5%	603	C1608COG1H390J	TDK
C7	1	1200 pF	Capacitor, ceramic, 50-V, COG, 5%	603	C1608COG1H122J	TDK
C1	2	4.7 $\mu$ F	Capacitor, ceramic, 25-V, X7R, 10%	1206	C3216X7R1E475K	TDK
C3		4.7 $\mu$ F	Capacitor, ceramic, 25-V, X7R, 10%	1206	C3216X7R1E475K	TDK
C9	1	10 $\mu$ F	Capacitor, ceramic, 16-V, X7R, 10%	1206	C3216X7R1C106K	TDK
C2	1	220 $\mu$ F	Capacitor, aluminum electrolytic, 25-V, 20%	0.315 inch	25ZL220M8x11.5	Rubycon
D1	1	MBRA140LT3	Diode, Schottky, 1-A, 40-V	SMA	MBRA140LT3	ON Semi
L1	1	1.5 $\mu$ H	Inductor, SMT, 4-A, 33-m $\Omega$	0.255 x 0.270 inch	IHLP2525AH-01	Vishay
L2	1	4.7 $\mu$ H	Inductor, SMT, 3-A, 77-m $\Omega$	0.255 x 0.270 inch	IHLP2525AH-01	Vishay
R10	1	0	Resistor, chip, 1/16-W, 1%	603	Standard	Standard
R8	1	1.87k	Resistor, chip, 1/16-W, 1%	603	Standard	Standard
R11	1	10	Resistor, chip, 1/16-W, 1%	603	Standard	Standard
R7	2	10k	Resistor, chip, 1/16-W, 1%	603	Standard	Standard
R9		10k	Resistor, chip, 1/16-W, 1%	603	Standard	Standard
R6	1	20.5k	Resistor, chip, 1/16-W, 1%	603	Standard	Standard
R5	1	53.6k	Resistor, chip, 1/16-W, 1%	603	Standard	Standard
R4	1	78.7k	Resistor, chip, 1/16-W, 1%	603	Standard	Standard
R3	1	348k	Resistor, chip, 1/16-W, 1%	603	Standard	Standard
J1	1	ED1514	Terminal block, 2-pin, 6-A, 3.5-mm	0.27 x 0.25 inch	ED1514	OST
J2	1	ED1514	Terminal block, 2-pin, 6-A, 3.5-mm	0.27 x 0.25 inch	ED1514	OST
TP1	4	5001	Test point, black, through-hole color keyed	0.1 x 0.1 inch	5001	Keystone
TP2		5001	Test point, black, through-hole color keyed	0.1 x 0.1 inch	5001	Keystone
TP3		5001	Test point, black, through-hole color keyed	0.1 x 0.1 inch	5001	Keystone
TP4		5001	Test point, black, through-hole color keyed	0.1 x 0.1 inch	5001	Keystone
U1	1	TPS54160DGQRQ1	IC, DC-DC converter, 60-V 1.5-A	MSOP-10	TPS54160DGQRQ1	TI

### 1.3 PCB Layout

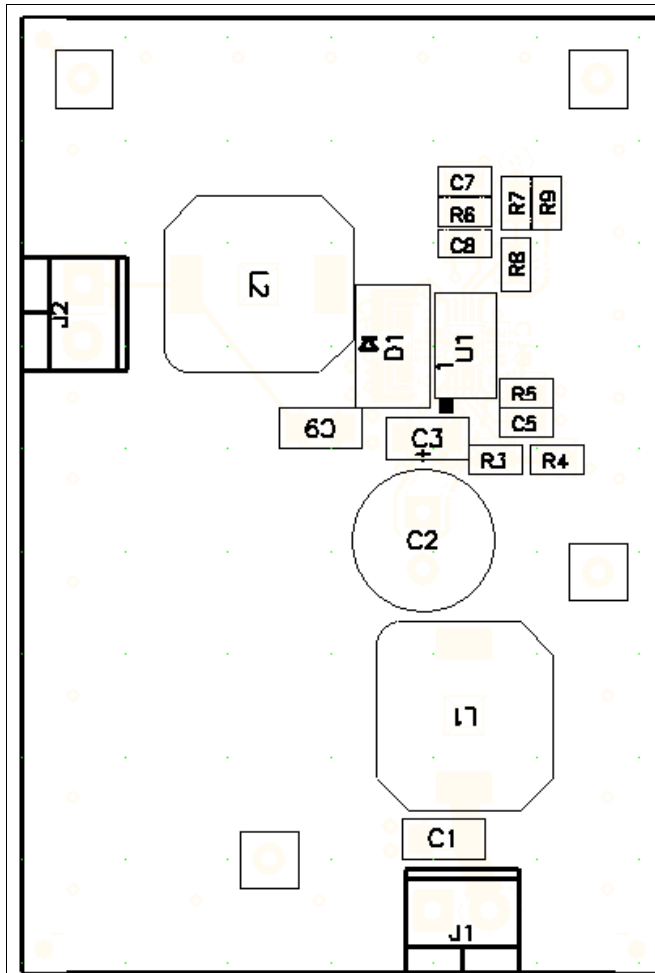


Figure 2. Top Assembly

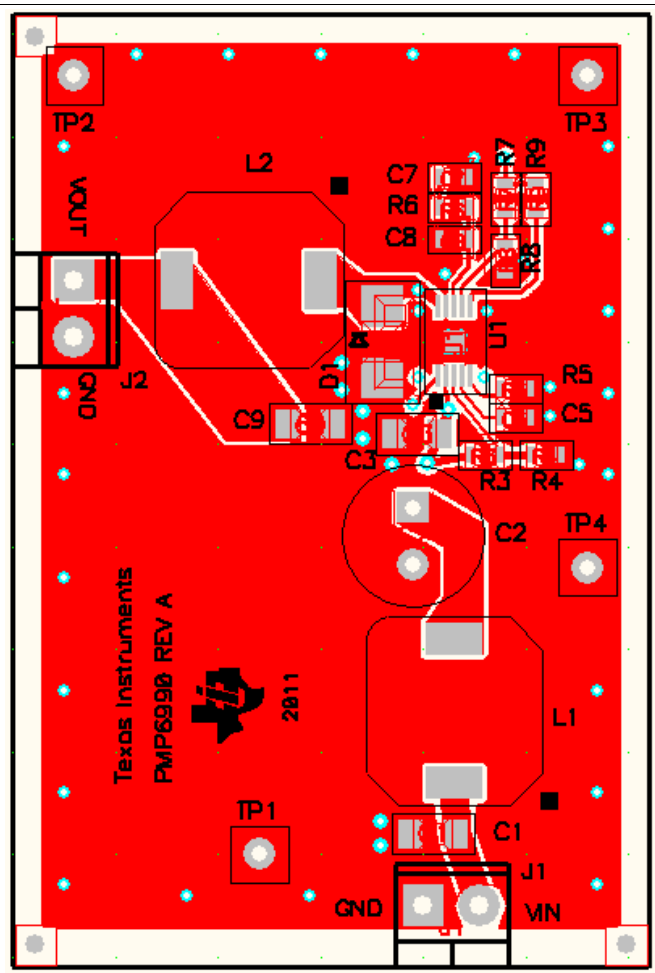


Figure 3. Top-Layer Silkscreen and Routing

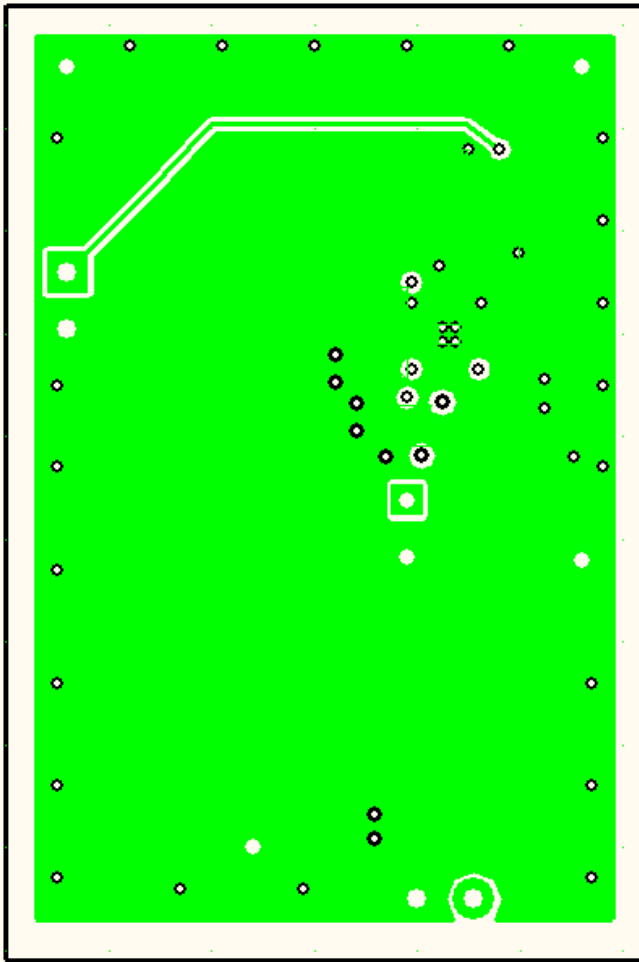


Figure 4. Layer 2 Routing

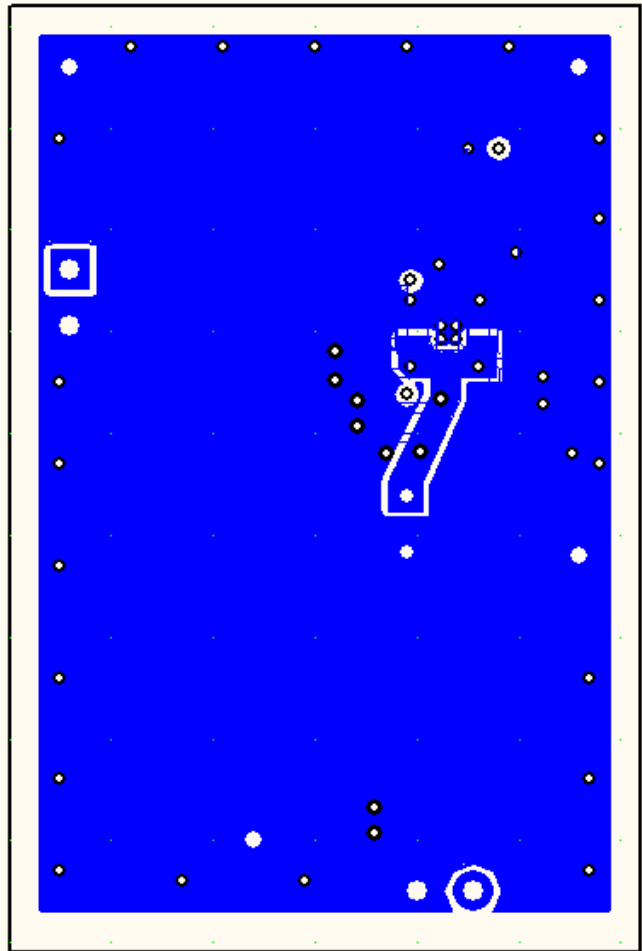


Figure 5. Layer 3 Routing

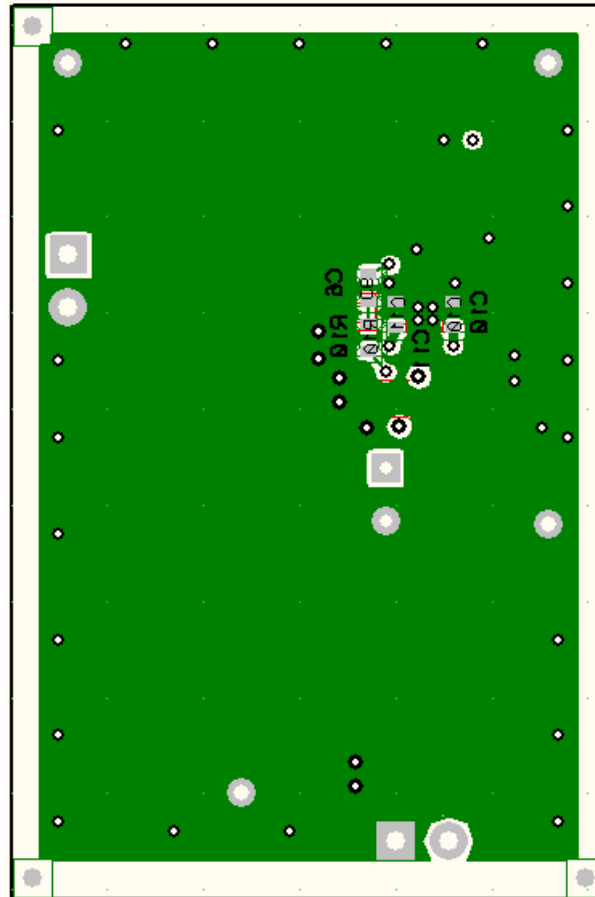


Figure 6. Bottom-Layer Silkscreen and Routing

### 1.4 R-C Snubber Added From PH to GND

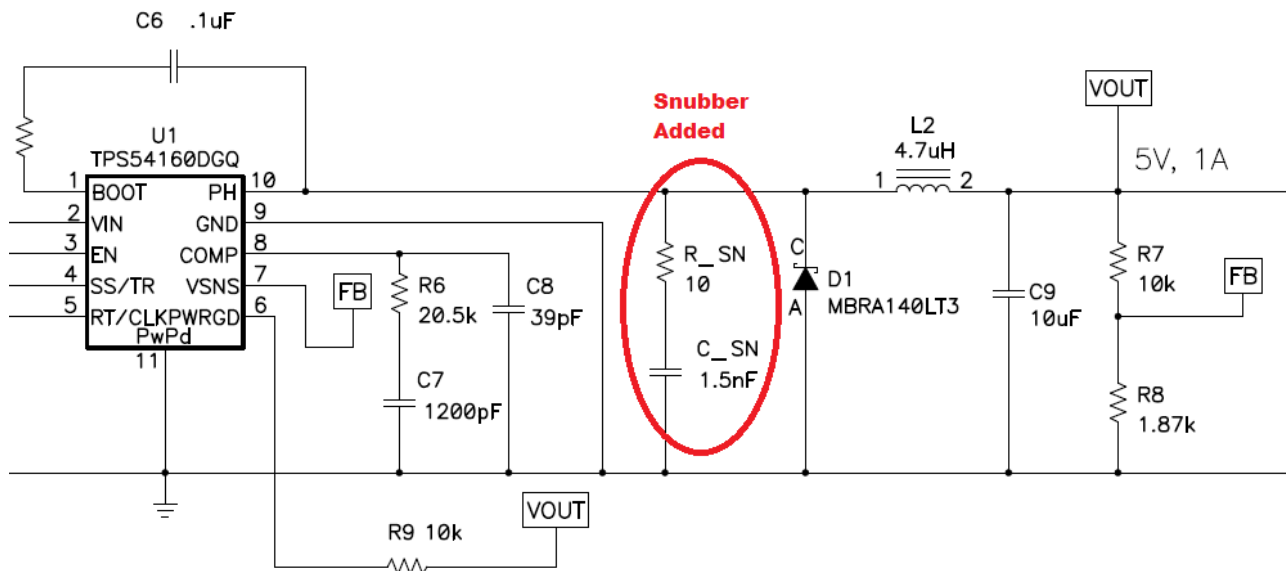


Figure 7. With Snubber Added

## 2 Description and Setup for Radiated Emissions Measurements

PMP6990 Revision-A board was used for all radiated emissions testing. The test results confirm that the board can pass CISPR25, Class 4 according to the bill of materials listed in [Table 1](#). In order to pass CISPR25, Class 5, an additional R-C snubber ( $R = 10 \Omega$ ,  $C = 1.5 \text{ nF}$ ) was added in parallel across diode D1. The snubber was used to slow down the rise and fall times of the switching voltages and currents generated by the PH pin which resulted in lower noise in the 30-MHz to 200-MHz range. The snubber power dissipation is  $C_{\text{SN}} \times (V_{\text{IN}})^2 \times F_{\text{SW}}$ . At 1.5 nF and 2 MHz, the power dissipation is 432 mW, which is the power dissipated in the resistor R\_SN. The power rating of the resistor is 500 mW. The capacitor can be 0603, but the resistor package is 2020.

[Figure 7](#) shows the buck-converter circuit using the R-C snubber. This snubber circuit is included in the new PMP6990 Revision-B reference board.

[Section 2.1](#) and [Section 2.2](#) list the setup conditions and test results.

### 2.1 Setup Conditions

**Device under test (DUT)**— PMP6990, Revision A using the TPS54160-Q1 device

**Input voltage**— Car battery, (BAT+) = 13.5 V, (BAT-) = GND

**Switching frequency**—  $f_{\text{SW}} = 2 \text{ MHz}$

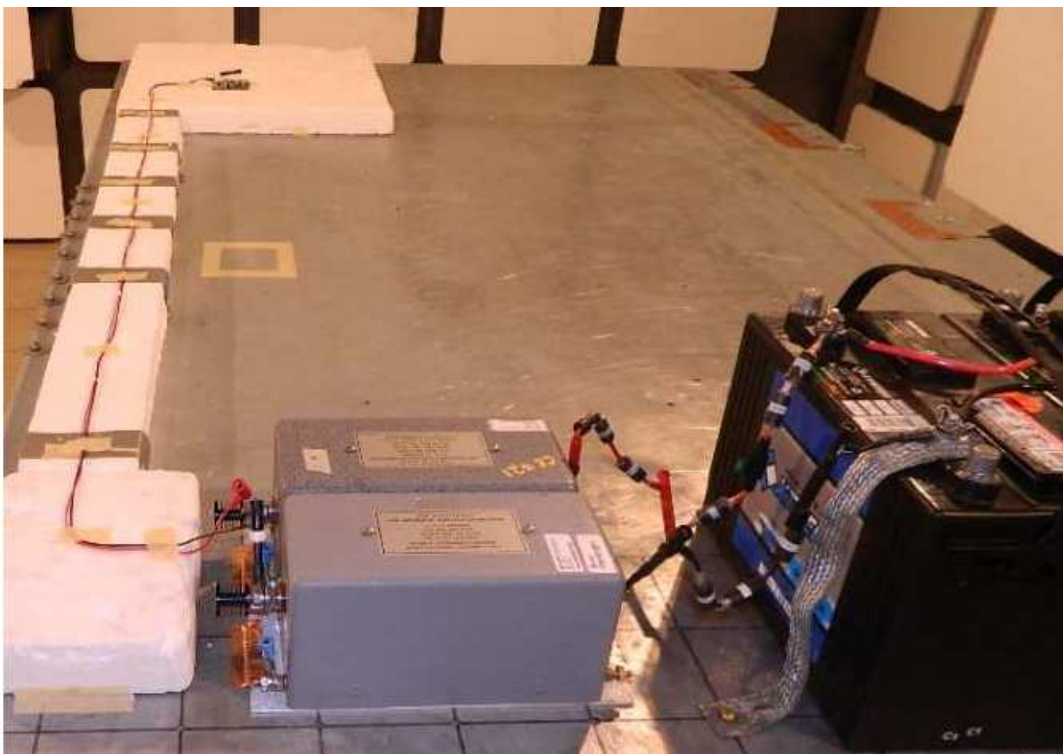
**Output voltage**—  $V_{\text{O}} = 5 \text{ V}$

**Load current**—  $I_{\text{O}} = 1 \text{ A}$

**Length of wire harness**— (BAT+ / BAT-) = 1,7 m

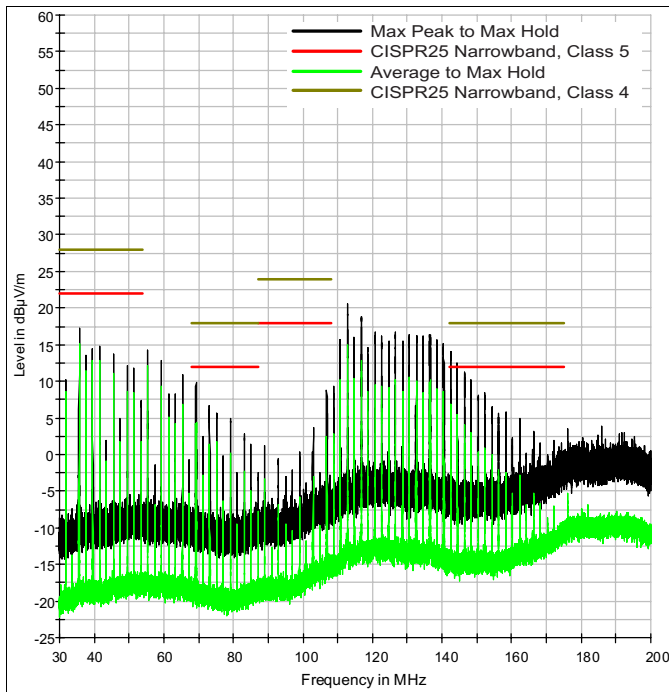
CISPR25 line-impedance stabilization networks (LISN) placed between BAT+/BAT- and wire harness

Wire harness and DUT are placed on 50 mm of insulation with respect to the test table.

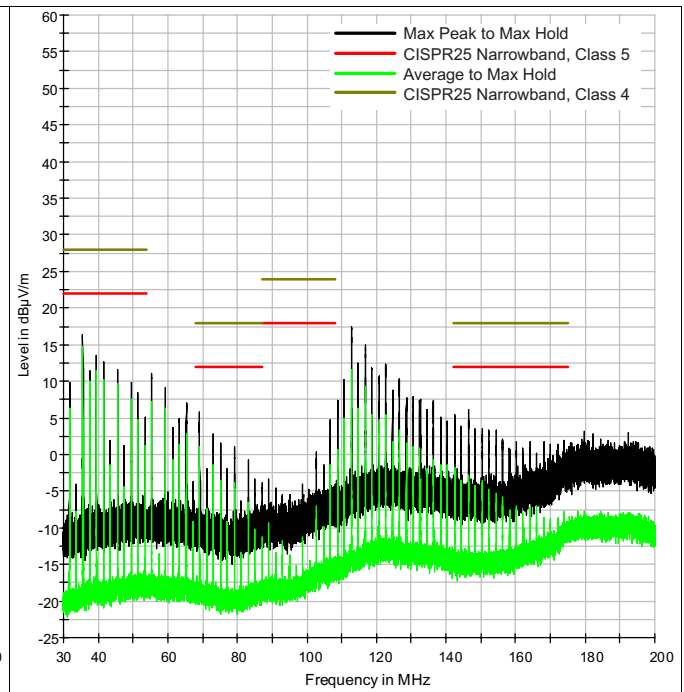


**Figure 8. Test Setup**

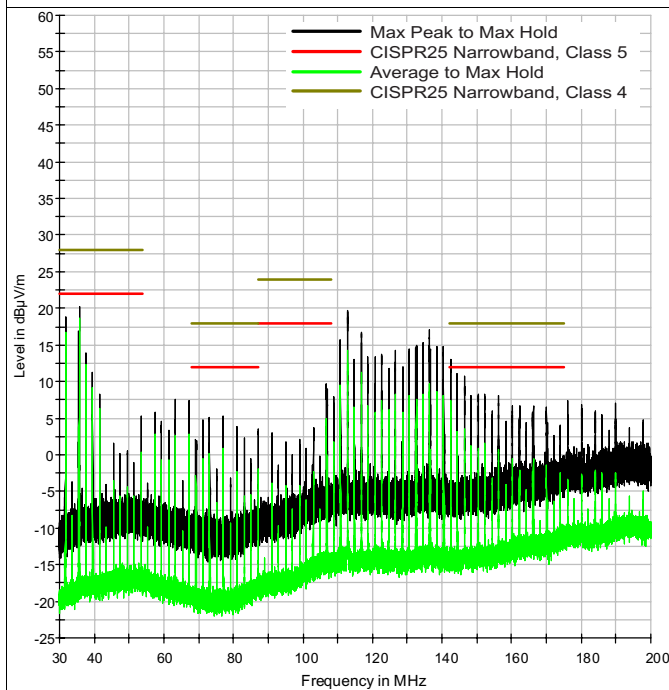
## 2.2 Test Results



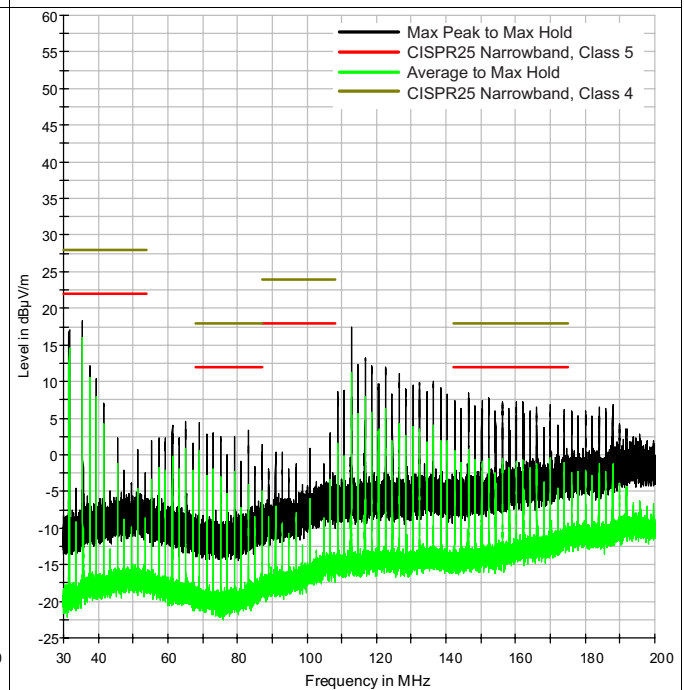
**Figure 9. CISPR25 Bicon Horizontal Results No R-C Snubber**



**Figure 10. CISPR25 Bicon Horizontal Results With R-C Snubber**



**Figure 11. CISPR25 Bicon Vertical Results No R-C Snubber**



**Figure 12. CISPR25 Bicon Vertical Results With R-C Snubber**



**Table 2. Comparison of Results, With and Without R-C Snubber**

Test	No Snubber	10-Ω, 1.5-nF Snubber Added
CISPR25 Bicon H	PASS Class 4	PASS Class 4
	FAIL Class 5 at 142 MHz	PASS Class 5
CISPR25 Bicon V	PASS Class 4	PASS Class 4
	FAIL Class 5 at 142 MHz	PASS Class 5

### 3 Summary

The TPS54160-Q1 device family passes the CISPR25 Class-4 and Class-5 Radiated Emissions required for automotive. Passing results can be achieved using careful components selection, placement, and PCB layout. In some cases, an R-C snubber is required to help further suppress high frequency noise.

PMP6990 EMC test board has been revised to Revision B, which includes footprints for the R-C snubber circuit. For more information on the PMP6990 Revision-B board go to [www.ti.com](http://www.ti.com).

---

## Revision History

NOTE: Page numbers for previous revisions may differ from page numbers in the current version.

<b>Changes from Original (December 2013) to A Revision</b>	<b>Page</b>
• Added statement to the Description and Setup for Radiated Emissions Measurements section.....	<a href="#">7</a>

---

## IMPORTANT NOTICE AND DISCLAIMER

TI PROVIDES TECHNICAL AND RELIABILITY DATA (INCLUDING DATASHEETS), DESIGN RESOURCES (INCLUDING REFERENCE DESIGNS), APPLICATION OR OTHER DESIGN ADVICE, WEB TOOLS, SAFETY INFORMATION, AND OTHER RESOURCES "AS IS" AND WITH ALL FAULTS, AND DISCLAIMS ALL WARRANTIES, EXPRESS AND IMPLIED, INCLUDING WITHOUT LIMITATION ANY IMPLIED WARRANTIES OF MERCHANTABILITY, FITNESS FOR A PARTICULAR PURPOSE OR NON-INFRINGEMENT OF THIRD PARTY INTELLECTUAL PROPERTY RIGHTS.

These resources are intended for skilled developers designing with TI products. You are solely responsible for (1) selecting the appropriate TI products for your application, (2) designing, validating and testing your application, and (3) ensuring your application meets applicable standards, and any other safety, security, or other requirements. These resources are subject to change without notice. TI grants you permission to use these resources only for development of an application that uses the TI products described in the resource. Other reproduction and display of these resources is prohibited. No license is granted to any other TI intellectual property right or to any third party intellectual property right. TI disclaims responsibility for, and you will fully indemnify TI and its representatives against, any claims, damages, costs, losses, and liabilities arising out of your use of these resources.

TI's products are provided subject to TI's Terms of Sale ([www.ti.com/legal/termsofsale.html](http://www.ti.com/legal/termsofsale.html)) or other applicable terms available either on [ti.com](http://ti.com) or provided in conjunction with such TI products. TI's provision of these resources does not expand or otherwise alter TI's applicable warranties or warranty disclaimers for TI products.

Mailing Address: Texas Instruments, Post Office Box 655303, Dallas, Texas 75265  
Copyright © 2019, Texas Instruments Incorporated