

DRV11873 Lock Detection Functionality

Krushal Shah

ABSTRACT

This document is provided as a supplement to the DRV11873 data sheet. It details how the DRV11873 can falsely detect a locked rotor and the recommended workaround procedures.

Contents

1	Introduction	2
2	False Lock Detection	2
2.1	Description of Circuit	2
2.2	Target Motor Speed is Fixed Inside the False Detection Range of 101.6 Hz \pm 30%.....	3
2.3	Target Motor Speed is Fixed Outside the False Detection Range of 101.6 Hz \pm 30%.....	3
2.4	Target Motor Speed is Variable With FG inside the False Detect Window	3
3	Conclusion	3

List of Figures

1	Timing of Internal Sampling Clock Versus FG Output	3
---	--	---

1 Introduction

The DRV11873 is an integrated device providing the benefits of low cost, low size, and ease of use. Under certain conditions, it has been determined that the lock detection mechanism can detect a locked rotor condition that is not real. If a locked rotor condition is incorrectly detected, the DRV11873 will stop driving the motor, wait for some time, and then re-start.

This false lock condition occurs when a number of conditions are met. The information in section 2 describes the condition in which the lock is incorrectly detected and recommended workaround procedures.

2 False Lock Detection

2.1 Description of Circuit

The lock detection circuit inside the DRV11873 monitors the FG signal to determine if the signal is static. If the FG signal is sampled as a static value for approximately 305 clocks of an internal sampling clock, the internal logic signals that the rotor is locked. When this condition occurs, the DRV11873 is reset and after approximately 5 seconds is restarted.

The internal sampling clock reference is set to approximately 101.6Hz, with a variance of $\pm 30\%$. This variance includes voltage, temperature, and process.

It has been observed that some devices falsely detect lock if the FG signal matches this internal sampling clock. An example is when the FG signal is within 0.16% of the sampling clock. When this condition occurs, the 305 samples will occur in either the high side or the low side of the FG signal.

[Figure 1](#) shows the internal sampling clock sampling a logical high on the FG signal for 5 consecutive samples. If this is continued through 305 samples, the internal lock detection signals that the rotor is locked.

The relationship of the variation of FG and the internal sampling clock are inversely proportional.

$$\text{FG Variation allowed} = 0.16\% / (\text{FG/Internal Sampling Clock})$$

As FG increases by a power of 2, the variation allowed decreases by the same power of 2. This means that it becomes less likely for a false lock to be detected as the motor speed increases.

As seen in [Figure 1](#), the sampling of FG at multiples of the internal sampling clock can also result in false lock conditions. As the FG frequency increases by even multiples of the sample clock, the allowable variation of the FG signal decreases. For example, if FG is twice the internal sampling clock the allowed variation of the FG signal reduces to 0.08%.

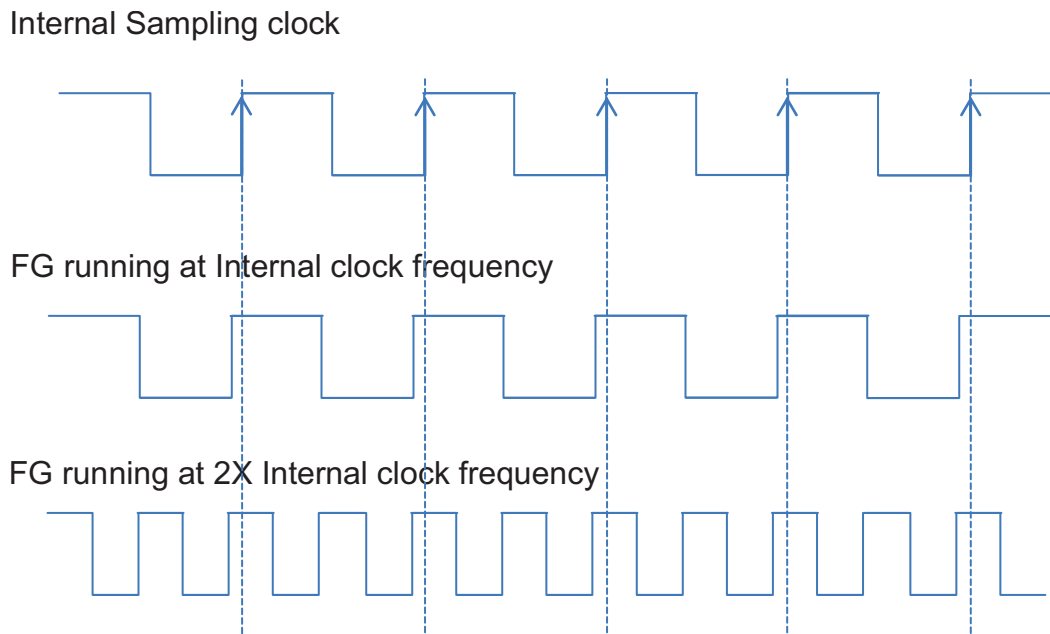

Figure 1. Timing of Internal Sampling Clock Versus FG Output

The false lock condition depends on several conditions. The motor speed can vary as the temperature of the device varies. The voltage of the DRV11873 can vary from board to board or system to system. The internal sampling clock can vary due to process variations

If the false lock is detected, the recommended workaround procedures are listed below. These workarounds depend on the application. In some applications, the target speed is fixed. In other applications, the target speed may vary from zero to the maximum motor speed.

2.2 Target Motor Speed is Fixed Inside the False Detection Range of 101.6 Hz \pm 30%

Use FGS input to change the FG frequency such that it will be outside of the window. The FG signal can either be increased or decreased by a multiple of 2 on power up by changing the FGS input.

2.3 Target Motor Speed is Fixed Outside the False Detection Range of 101.6 Hz \pm 30%

No action is required.

2.4 Target Motor Speed is Variable With FG Inside the False Detect Window

There are three possible actions if the lock detection occurs falsely. All actions change the speed of the motor:

- If using the PWM input to adjust the motor speed, raise or lower the PWM input duty cycle by 1%. This will move the FG signal away from the internal sampling clock frequency.
- If using V_{CC} to adjust the motor speed, raise or lower V_{CC} by 10 mV. This will move the FG signal away from the internal sampling clock frequency.
- Modulate the PWM input between 2 duty cycles 1% to 2% apart. Do this every 1 to 1.5 seconds to prevent the FG frequency matching the internal sampling frequency. The result is an average speed of the two PWM duty cycles.

3 Conclusion

The lock detect circuitry of the DRV11873 device can improperly report a rotor locked condition when several events align. The alignment of these events can be avoided by using the workarounds described above.

IMPORTANT NOTICE

Texas Instruments Incorporated and its subsidiaries (TI) reserve the right to make corrections, enhancements, improvements and other changes to its semiconductor products and services per JESD46, latest issue, and to discontinue any product or service per JESD48, latest issue. Buyers should obtain the latest relevant information before placing orders and should verify that such information is current and complete. All semiconductor products (also referred to herein as "components") are sold subject to TI's terms and conditions of sale supplied at the time of order acknowledgment.

TI warrants performance of its components to the specifications applicable at the time of sale, in accordance with the warranty in TI's terms and conditions of sale of semiconductor products. Testing and other quality control techniques are used to the extent TI deems necessary to support this warranty. Except where mandated by applicable law, testing of all parameters of each component is not necessarily performed.

TI assumes no liability for applications assistance or the design of Buyers' products. Buyers are responsible for their products and applications using TI components. To minimize the risks associated with Buyers' products and applications, Buyers should provide adequate design and operating safeguards.

TI does not warrant or represent that any license, either express or implied, is granted under any patent right, copyright, mask work right, or other intellectual property right relating to any combination, machine, or process in which TI components or services are used. Information published by TI regarding third-party products or services does not constitute a license to use such products or services or a warranty or endorsement thereof. Use of such information may require a license from a third party under the patents or other intellectual property of the third party, or a license from TI under the patents or other intellectual property of TI.

Reproduction of significant portions of TI information in TI data books or data sheets is permissible only if reproduction is without alteration and is accompanied by all associated warranties, conditions, limitations, and notices. TI is not responsible or liable for such altered documentation. Information of third parties may be subject to additional restrictions.

Resale of TI components or services with statements different from or beyond the parameters stated by TI for that component or service voids all express and any implied warranties for the associated TI component or service and is an unfair and deceptive business practice. TI is not responsible or liable for any such statements.

Buyer acknowledges and agrees that it is solely responsible for compliance with all legal, regulatory and safety-related requirements concerning its products, and any use of TI components in its applications, notwithstanding any applications-related information or support that may be provided by TI. Buyer represents and agrees that it has all the necessary expertise to create and implement safeguards which anticipate dangerous consequences of failures, monitor failures and their consequences, lessen the likelihood of failures that might cause harm and take appropriate remedial actions. Buyer will fully indemnify TI and its representatives against any damages arising out of the use of any TI components in safety-critical applications.

In some cases, TI components may be promoted specifically to facilitate safety-related applications. With such components, TI's goal is to help enable customers to design and create their own end-product solutions that meet applicable functional safety standards and requirements. Nonetheless, such components are subject to these terms.

No TI components are authorized for use in FDA Class III (or similar life-critical medical equipment) unless authorized officers of the parties have executed a special agreement specifically governing such use.

Only those TI components which TI has specifically designated as military grade or "enhanced plastic" are designed and intended for use in military/aerospace applications or environments. Buyer acknowledges and agrees that any military or aerospace use of TI components which have **not** been so designated is solely at the Buyer's risk, and that Buyer is solely responsible for compliance with all legal and regulatory requirements in connection with such use.

TI has specifically designated certain components as meeting ISO/TS16949 requirements, mainly for automotive use. In any case of use of non-designated products, TI will not be responsible for any failure to meet ISO/TS16949.

Products

Audio	www.ti.com/audio
Amplifiers	amplifier.ti.com
Data Converters	dataconverter.ti.com
DLP® Products	www.dlp.com
DSP	dsp.ti.com
Clocks and Timers	www.ti.com/clocks
Interface	interface.ti.com
Logic	logic.ti.com
Power Mgmt	power.ti.com
Microcontrollers	microcontroller.ti.com
RFID	www.ti-rfid.com
OMAP Applications Processors	www.ti.com/omap
Wireless Connectivity	www.ti.com/wirelessconnectivity

Applications

Automotive and Transportation	www.ti.com/automotive
Communications and Telecom	www.ti.com/communications
Computers and Peripherals	www.ti.com/computers
Consumer Electronics	www.ti.com/consumer-apps
Energy and Lighting	www.ti.com/energy
Industrial	www.ti.com/industrial
Medical	www.ti.com/medical
Security	www.ti.com/security
Space, Avionics and Defense	www.ti.com/space-avionics-defense
Video and Imaging	www.ti.com/video

TI E2E Community

e2e.ti.com