

# Using Non-Inverting Buck-Boost Converter for Voltage Stabilization

Milos Acanski

## ABSTRACT

Having a stable and accurate voltage supply is crucial for proper operation of electronic devices. For practical, design or cost reasons, under some conditions the voltage supply might fall outside the requirements. For example, this can happen if a large transient occurs on a shared voltage rail, if long cables are used to provide power supply, or due to loose voltage tolerance of the pre-regulator. To ensure proper operation of sensitive parts of the system, a voltage stabilizer can be used as a buffer between the power supply and the sensitive block. This application note presents the buck-boost converter as a voltage stabilizer, and discusses several parameters that have to be taken into account when selecting the right device for voltage stabilization.

## Contents

1	Introduction .....	2
2	Buck-boost Converter as a Voltage Stabilizer .....	2
3	Case Study for 3.3-V Voltage Stabilization .....	3
4	Summary .....	7
5	References .....	7

## List of Figures

1	An Example of a Power Branch .....	2
2	Non-inverting Buck-Boost Converter Schematic .....	3
3	Typical Buck-Boost Mode Waveforms for the TPS63020 at $V_I = V_O = 3.3\text{ V}$ , $I_O = 0.5\text{ A}$ .....	4
4	Mode Transition Thresholds for the TPS63020 at $V_O = 3.3\text{ V}$ .....	4
5	Typical Buck-Boost Mode Waveforms for the TPS63802 at $V_I = V_O = 3.3\text{ V}$ , $I_O = 0.5\text{ A}$ .....	4
6	Mode Transition Thresholds for the TPS63802 at $V_O = 3.3\text{ V}$ .....	4
7	Line Transient Response for the TPS63020 at $V_I = V_O = 3.3\text{ V}$ , $\Delta V_I = \pm 0.5\text{ V}$ .....	5
8	Line Transient Response for the TPS63802 at $V_I = V_O = 3.3\text{ V}$ , $\Delta V_I = \pm 0.5\text{ V}$ .....	5
9	Load Transient Response for the TPS63020 at $V_I = V_O = 3.3\text{ V}$ , $\Delta I_O = \pm 1\text{ A}$ .....	6
10	Load Transient Response for the TPS63802 at $V_I = V_O = 3.3\text{ V}$ , $\Delta I_O = \pm 1\text{ A}$ .....	6
11	Mode Change Due to Load Transient for the TPS63020 at $V_I = V_O = 3.3\text{ V}$ , $\Delta I_O = 1\text{ A}$ .....	6
12	Mode Change Due to Load Transient for the TPS63802 at $V_I = V_O = 3.3\text{ V}$ , $\Delta I_O = 1\text{ A}$ .....	6

## List of Tables

1	Main Specifications for TPS63020 and TPS63802 .....	3
---	---	---

## Trademarks

HotRod is a trademark of Texas Instruments.

All other trademarks are the property of their respective owners.

## 1 Introduction

In many modern electronic systems, there are multiple parts that require different supply voltages. Often, several parts can share the same voltage rail. As an example, [Figure 1](#) one such power branch where a pre-regulator is used to obtain a 3.3-V rail shared by multiple blocks. Under some conditions, the voltage supply can fall outside the requirements, potentially causing malfunction of sensitive parts. For example:

- Some blocks containing high-current loads, such as motors, LED drivers, or RF amplifiers, can have large load transients that can cause voltage drops or overshoots on the shared voltage rail. Other blocks containing light loads, such as signal amplifiers, sensors, or MCUs, can be sensitive to these disturbances in the supply voltage.
- Sometimes, long power supply cables are used to connect remote parts of the system. The added resistance and inductance of the power supply line can cause the voltage supply to fall out of specifications for heavy loads or during aggressive load transients.
- Sensitive devices can require tighter tolerance of the supply voltage than the one provided by the pre-regulator (for example  $\pm 1\%$  instead of  $\pm 5\%$ ).

In such cases, it is essential to stabilize the supply voltage and prevent interference. In case of large load transients, stabilize the voltage to add more capacitance to the voltage rail. Another solution is to add a power supply filter in front of the sensitive block. This can significantly increase the solution cost and size, depending on the attenuation needed to suppress the voltage fluctuations. If the goal is to tighten the tolerance of the power supply, filtering alone does not help, and an active regulation is needed.

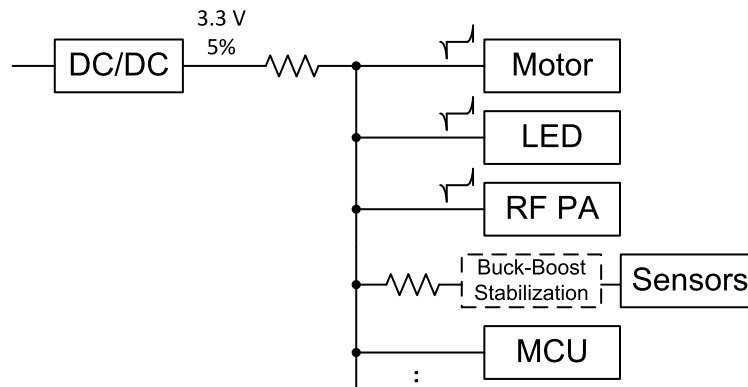

**Figure 1. An Example of a Power Branch**

## 2 Buck-boost Converter as a Voltage Stabilizer

A 4-switch non-inverting buck-boost converter, such as the TPS63802 or TPS63020, is able to increase or decrease voltage. Therefore, it can be used for active voltage stabilization for sensitive parts, as shown in [Figure 1](#). The non-inverting buck-boost converter consists of a buck converter and a boost converter that share the same inductor, as shown in [Figure 2](#). See the [Under the Hood of a Noninverting Buck-Boost Converter White Paper](#) for more information about the non-inverting buck-boost converter. See the [Basic Calculations of a 4-switch Buck-Boost Power Stage Application Report](#) for instructions on how to size the components for such converter.

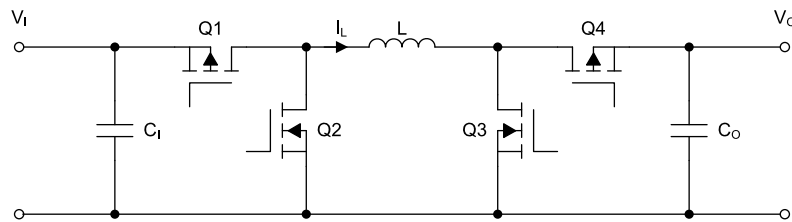
**Figure 2. Non-inverting Buck-Boost Converter Schematic**

There are different switching sequences that can be implemented in order to increase or decrease the input voltage. To increase the efficiency, three operating modes are usually implemented in TI devices, depending on the input and output voltages:

- For  $V_i > V_o$ , the converter operates in buck mode, where  $Q_1$  and  $Q_2$  are switching,  $Q_3$  is always off, and  $Q_4$  is always on.
- For  $V_i < V_o$ , the converter operates in boost mode, where  $Q_3$  and  $Q_4$  are switching,  $Q_1$  is always on, and  $Q_2$  is always off.
- For  $V_i \approx V_o$ , the converter operates in buck-boost mode. Here, there are several possibilities for switching patterns. For example, the TPS63020 alternates between the buck and boost switching cycles, whereas the TPS63802 has a defined 4-cycle buck-boost mode.

In case of voltage stabilization, the converter is expected to operate in buck-boost mode since  $V_i \approx V_o$ . Transitions between the operating modes depend on the input and output voltage and the transition voltage thresholds implemented in the particular device. When the operating mode is changed, a short disturbance can be expected on the output of the converter due to the change in dynamics and operating parameters. For the output voltage to be stable, try to stay in buck-boost mode for as wide of input voltage range as possible.

Buck-boost converters, and DC/DC converters in general, can also operate in different power modes. To improve efficiency at light loads, power-save mode can be implemented. In power-save mode under light loads, the converter operates in short bursts just often enough to maintain the output voltage. This is contrary to the forced-PWM mode where the converter is constantly switching. However, operation in power-save mode generally increases the output voltage ripple and decreases the regulation speed and voltage accuracy. Since these parameters are critical for voltage stabilization, the converter must operate in forced-PWM mode when being used as a voltage stabilizer. The result of the forced-PWM operation is decreased efficiency at light loads.

### 3 Case Study for 3.3-V Voltage Stabilization

To demonstrate the effectiveness of the buck-boost converter as a voltage stabilizer, the TPS63020 and the TPS63802 are evaluated for voltage stabilization at 3.3 V. [Table 1](#) lists the main specifications for these two devices.

**Table 1. Main Specifications for TPS63020 and TPS63802**

	TPS63020	TPS63802	COMMENT
$V_i$ (V)	1.8 - 5.5	1.3–5.5	
$V_o$ (V)	1.2 - 5.5	1.8–5.5	
$I_o$ (A)	2.5	2.5	$V_{IN} = V_{OUT} = 3.3$ V
$I_{i, no\ load}$ (mA)	6	12	$V_{IN} = V_{OUT} = 3.3$ V, forced-PWM mode
$C_i$ ( $\mu$ F)	2 x 10	10	
L ( $\mu$ H)	1.5	0.47	
$C_o$ ( $\mu$ F)	3 x 22	22	
Package	VSON (3 mm x 4 mm)	HotRod™ QFN (3 mm x 2 mm)	

Table 1 shows that the TPS63020 and the TPS63802 are similarly-rated devices. Table 1 also shows that the TPS63802 requires smaller passive components, leading to a smaller solution size. The main functional difference is in the way they operate in buck-boost mode and in the way they transition between the operating modes.

The TPS63020 alternates between buck and boost switching cycles when operating in buck-boost mode. Specifically in this condition, no more than three cycles in a row of the same mode are allowed. When the input voltage is closed to the output voltage, one buck cycle is always followed by a boost cycle. This control method in the buck-boost region ensures a robust control and the highest efficiency. Figure 3 shows the typical waveforms of the inductor current and switch node voltages. There is a seamless transition between the operating modes that does not depend on the direction of the transition. Figure 4 shows the operating modes depending on the input voltage and output current for  $V_o = 3.3\text{ V}$ .

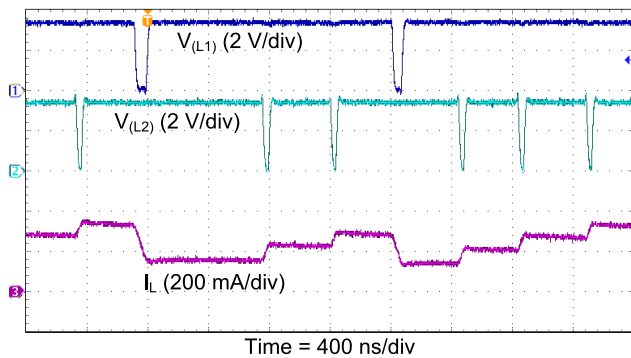

Figure 3. Typical Buck-Boost Mode Waveforms for the TPS63020 at  $V_i = V_o = 3.3\text{ V}$ ,  $I_o = 0.5\text{ A}$

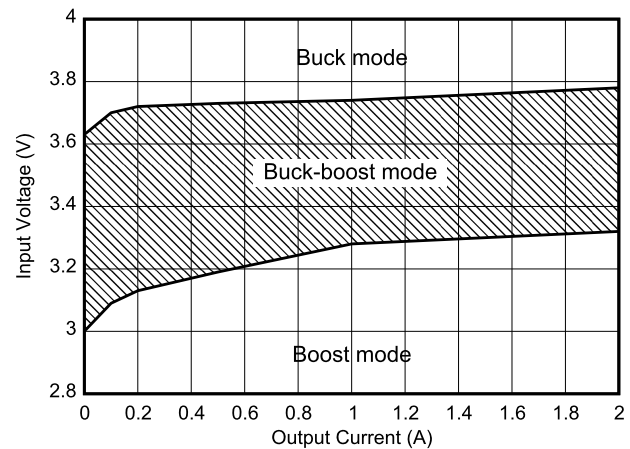

Figure 4. Mode Transition Thresholds for the TPS63020 at  $V_o = 3.3\text{ V}$

The TPS63802 has a defined 4-cycle buck-boost operation when operating in buck-boost mode. In this mode, all four switches are active. The RMS current through the switches and the inductor is kept at a minimum, to minimize switching and conduction losses. Controlling the switches this way allows the converter to always keep high efficiency over the complete input voltage range. Figure 5 shows the typical waveforms of the inductor current and switch node voltages. Contrary to the TPS63020, in the TPS63802, there is a hysteresis between the mode changes, as shown in Figure 6. This prevents the device from constant mode change when operating on the boundaries of buck-boost mode. Moreover, this results in a wider buck-boost mode area compared to the TPS63020. This is beneficial for voltage stabilization, since the converter stays longer in buck-boost mode in presence of large disturbances.

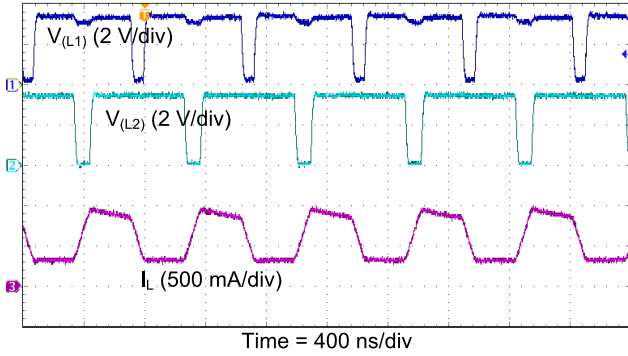

Figure 5. Typical Buck-Boost Mode Waveforms for the TPS63802 at  $V_i = V_o = 3.3\text{ V}$ ,  $I_o = 0.5\text{ A}$

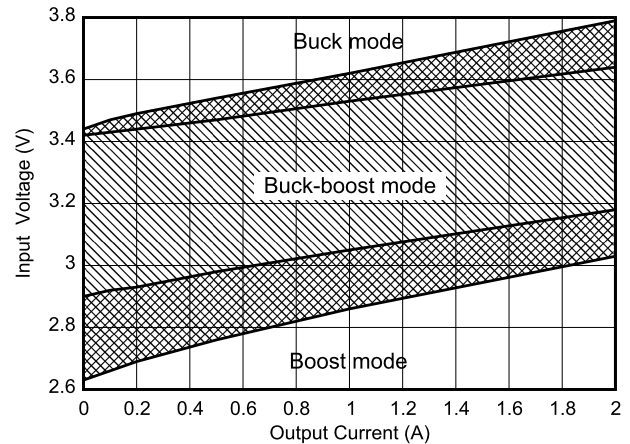

Figure 6. Mode Transition Thresholds for the TPS63802 at  $V_o = 3.3\text{ V}$

In the following, both devices are evaluated for line and load transients. The converters are tested on their evaluation modules (EVMs) with the recommended values for the external components, as listed in Table 1. Note that the TPS63020 EVM uses more capacitance, with  $C_o = 3 \times 22\ \mu\text{F}$ , whereas the EVM for the TPS63802 only has  $C_o = 22\ \mu\text{F}$ . For previously noted reasons, both devices are operating in forced-PWM mode. Figure 7 and Figure 8 show the line transient response at  $I_o = 1\text{ A}$  for  $\Delta V_i = \pm 0.5\text{ V}$ . Both converters show similar line transient response across the output current range, suppressing both positive and negative line transients, even under high load. The TPS63020 shows slightly better results than the TPS63802, but at the cost of more capacitance and larger inductance.

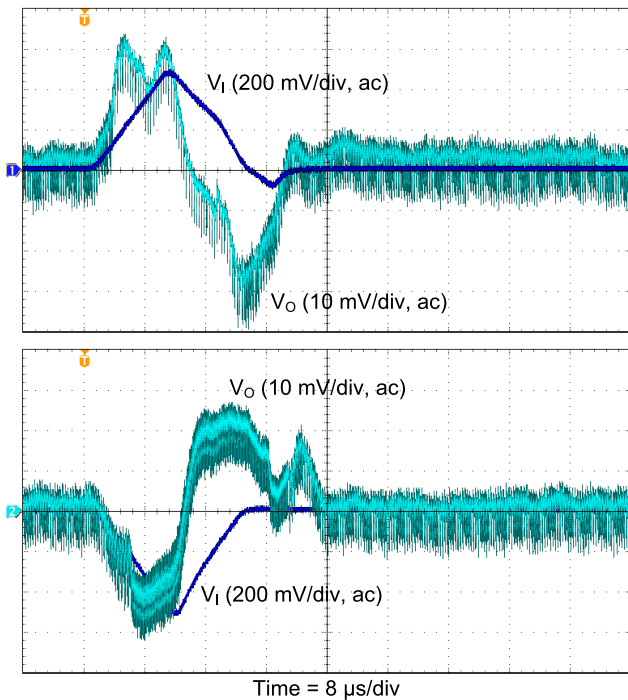

Figure 7. Line Transient Response for the TPS63020 at  $V_i = V_o = 3.3\text{ V}$ ,  $\Delta V_i = \pm 0.5\text{ V}$

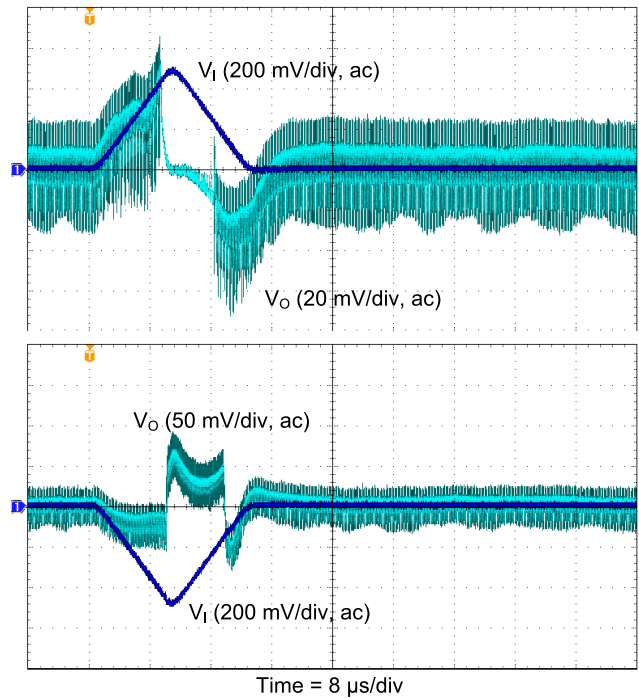
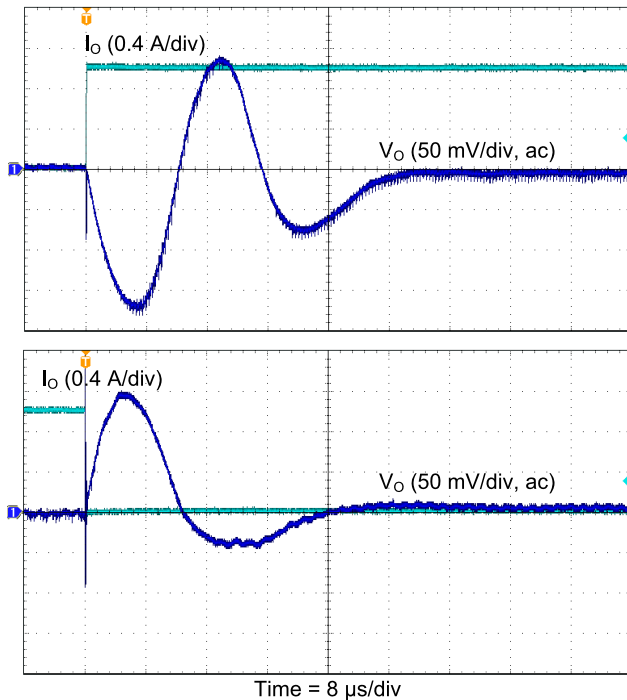
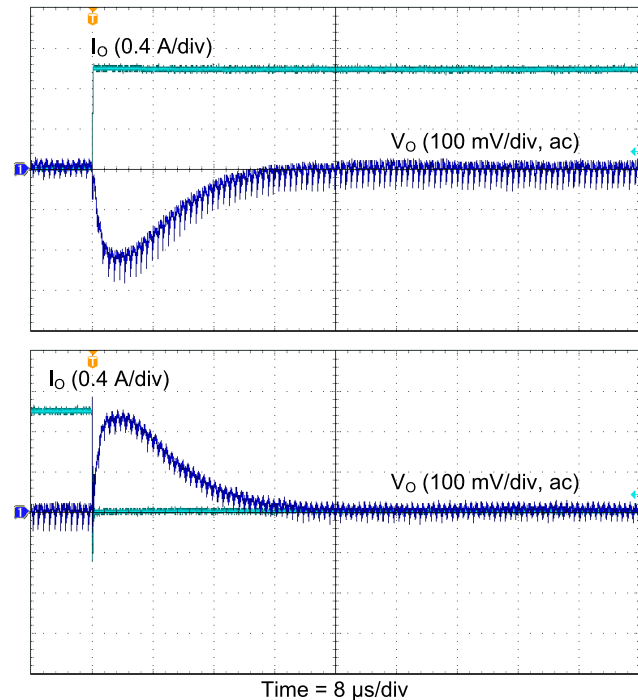

Figure 8. Line Transient Response for the TPS63802 at  $V_i = V_o = 3.3\text{ V}$ ,  $\Delta V_i = \pm 0.5\text{ V}$

Figure 9 and Figure 10 show the load transient response at  $V_i = V_o = 3.3$  V for  $\Delta I_o = \pm 1$  A. Both converters show similar deviations, with the TPS63020 showing slightly lower undershoots and overshoots. Note that the TPS63020 requires more capacitance, but still shows more oscillations in the response at heavier load transients, compared to the TPS63802. This is due to the larger output capacitance and the transients forcing the TPS63020 to change modes, as shown in Figure 11.

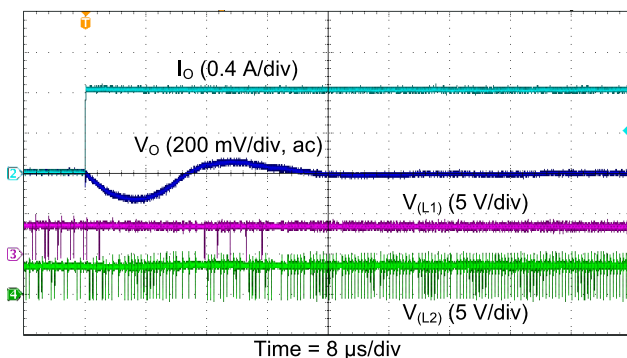

**Figure 9. Load Transient Response for the TPS63020 at  $V_i = V_o = 3.3$  V,  $\Delta I_o = \pm 1$  A**

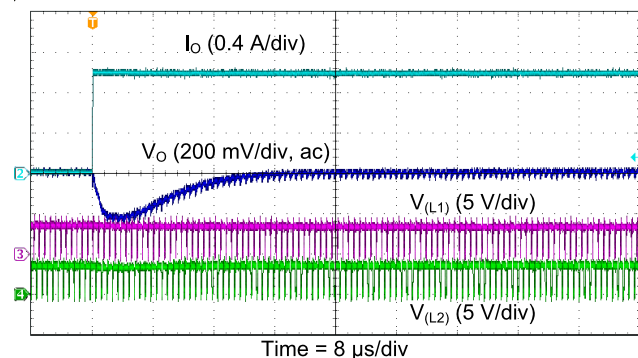

**Figure 10. Load Transient Response for the TPS63802 at  $V_i = V_o = 3.3$  V,  $\Delta I_o = \pm 1$  A**

As shown in Figure 12, the TPS63802 does not change modes during the load transient due to the wider buck-boost mode area and the hysteresis between the modes. The TPS63802 achieves slightly larger undershoots and overshoots when compared to the TPS63020, but the lower capacitance, and inductance values, and the small chip-scale package result in a smaller solution size.



**Figure 11. Mode Change Due to Load Transient for the TPS63020 at  $V_i = V_o = 3.3$  V,  $\Delta I_o = 1$  A**



**Figure 12. Mode Change Due to Load Transient for the TPS63802 at  $V_i = V_o = 3.3$  V,  $\Delta I_o = 1$  A**

In the end, choosing the right buck-boost converter between the TPS63020 and TPS63802 depends on the design goals. The TPS63020 in general shows better performance when compared to the TPS63802, with smaller  $V_o$  overshoots and undershoots during line and load transients. If the output voltage requirements can be more relaxed, the TPS63802 is the right choice as it offers significantly smaller solution size.

#### 4 Summary

Non-inverting buck-boost converters can increase or decrease voltage, and can be used for active voltage stabilization in order to suppress the input voltage transients, compensate for the power line impedance, or tighten the voltage tolerance. This application note evaluates two typical buck-boost converters from the TPS63xxx family. Depending on the design goals, the trade-off between transient response and solution size determines which converter is the right choice.

#### 5 References

- Texas Instruments, [Under the Hood of a Non-inverting Buck-Boost Converter White Paper](#) (SLUP346)
- Texas Instruments, [Basic Calculations of a 4 Switch Buck-Boost Power Stage Application Report](#) (SLVA535)
- Texas Instruments, [TPS6302x High Efficiency Single Inductor Buck-Boost Converter With 4-A Switches Datasheet](#) (SLVS916)
- Texas Instruments, [TPS63802 2-A , High-Efficient, Low  \$I\_o\$  Buck-Boost Converter with Small Solution Size Datasheet](#) (SLVSEU9)



## IMPORTANT NOTICE AND DISCLAIMER

TI PROVIDES TECHNICAL AND RELIABILITY DATA (INCLUDING DATASHEETS), DESIGN RESOURCES (INCLUDING REFERENCE DESIGNS), APPLICATION OR OTHER DESIGN ADVICE, WEB TOOLS, SAFETY INFORMATION, AND OTHER RESOURCES "AS IS" AND WITH ALL FAULTS, AND DISCLAIMS ALL WARRANTIES, EXPRESS AND IMPLIED, INCLUDING WITHOUT LIMITATION ANY IMPLIED WARRANTIES OF MERCHANTABILITY, FITNESS FOR A PARTICULAR PURPOSE OR NON-INFRINGEMENT OF THIRD PARTY INTELLECTUAL PROPERTY RIGHTS.

These resources are intended for skilled developers designing with TI products. You are solely responsible for (1) selecting the appropriate TI products for your application, (2) designing, validating and testing your application, and (3) ensuring your application meets applicable standards, and any other safety, security, or other requirements. These resources are subject to change without notice. TI grants you permission to use these resources only for development of an application that uses the TI products described in the resource. Other reproduction and display of these resources is prohibited. No license is granted to any other TI intellectual property right or to any third party intellectual property right. TI disclaims responsibility for, and you will fully indemnify TI and its representatives against, any claims, damages, costs, losses, and liabilities arising out of your use of these resources.

TI's products are provided subject to TI's Terms of Sale ([www.ti.com/legal/termsofsale.html](http://www.ti.com/legal/termsofsale.html)) or other applicable terms available either on [ti.com](http://ti.com) or provided in conjunction with such TI products. TI's provision of these resources does not expand or otherwise alter TI's applicable warranties or warranty disclaimers for TI products.

Mailing Address: Texas Instruments, Post Office Box 655303, Dallas, Texas 75265  
Copyright © 2019, Texas Instruments Incorporated