

Design considerations for a resistive feedback divider in a DC/DC converter

By Darwin Fernandez

Applications Engineer

Introduction

The resistive divider is the most common network in any DC/DC converter's feedback system. However, it is often misjudged as a circuit that simply sets the output voltage by scaling it down to a reference voltage. After computing the proper divider ratio, power-supply designers must make careful considerations when choosing the actual resistance values because they influence the overall performance of the converter. This article discusses the design considerations for the resistive divider in a feedback system and how the divider affects a converter's efficiency, output-voltage accuracy, noise sensitivity, and stability.

Efficiency

Switching DC/DC converters have relatively high efficiencies because they provide power transfer to a load through low-loss components such as capacitors, inductors, and switches. High efficiencies allow for a longer battery life and, consequently, an extended operational time for portable devices.

For low-power DC/DC converters, a typical design for resistive feedback requires the total resistance of the divider resistors ($R1 + R2$) to be very large (up to 1 M Ω). This minimizes the current through the feedback divider.

This current is in addition to the load, which means that for lower feedback-divider resistances, the battery must supply more current and more power for the same load. Hence, efficiency is lowered. This is undesirable, especially in portable applications where battery life is important.

Design example 1

Figure 1 confirms that efficiency drops at low loads with lower feedback resistances. In this example, the Texas Instruments (TI) TPS62060EVM was used with $V_{IN} = 5$ V, $V_{OUT} = 1.8$ V, and power-save mode enabled. At high-load currents, the power dissipated by the load was much larger than the power dissipated by the resistive-feedback network. This is why the efficiencies for different $R1$ and $R2$ values converge at higher-load currents. However, at low-load currents, the differences in efficiency for different feedback resistances are more prominent. This is because the current through the divider dominated the current through the load. Therefore, to have higher efficiencies at light loads, it is good design practice to use the large feedback resistances recommended in the datasheet. If efficiency at light loads is not important in a given design, then smaller resistances can be used with essentially no impact on efficiency.

Figure 1. Efficiency of TPS62060 buck converter with different feedback-divider resistances

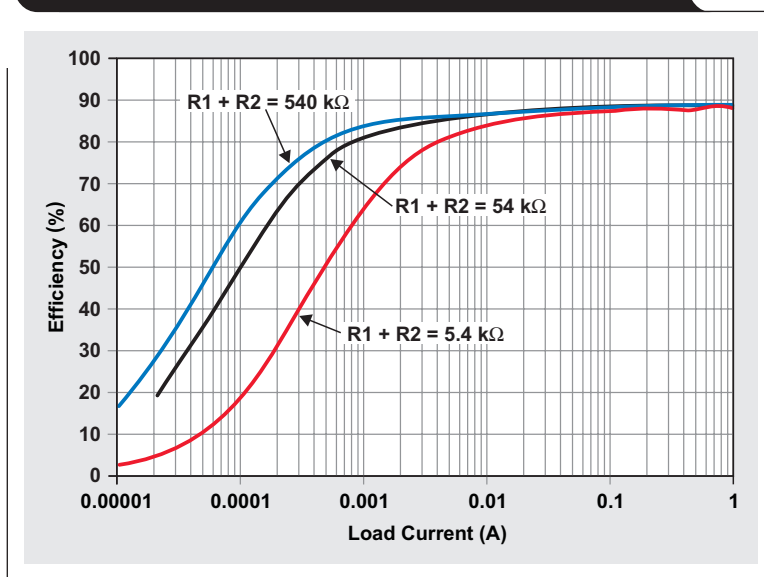

Output-voltage accuracy

Using large feedback resistances to increase efficiency was just discussed. However, choosing resistances that are too large affects the converter's output-voltage accuracy because of leakage current going into the converter's feedback pin. Figure 2 shows the current paths at the resistive feedback divider (R1 and R2). For a fixed feedback leakage current (I_{FB}), current through R1 (I_{R1}) decreases as the values of R1 and R2 increase. Therefore, an increase in divider resistance means that a larger percentage of I_{R1} leaks into the feedback pin, and the current through R2 (I_{R2}) decreases, causing a lower feedback-pin voltage (V_{FB}) than expected. Since V_{FB} is compared to an internal reference voltage to set the output voltage, any inaccuracies in the feedback voltage create inaccuracies in the output voltage. Equation 1 can be derived from Kirchhoff's Current Law, showing V_{FB} as a function of R1 and R2:

$$V_{FB} = R2 \times \frac{V_{OUT} - I_{FB}R1}{R1 + R2} \quad (1)$$

Note that I_{FB} is not fixed in a real system and can vary from device to device and over the operating conditions. To generate a worst-case estimate of the output-voltage change that is due to the leakage current, the specified maximum value of I_{FB} is used in the calculations.

Design example 2

Equation 1 and the TI TPS62130 step-down converter were used to graph the feedback-pin voltage and the corresponding output voltage as functions of the feedback-divider

Figure 2. Leakage current going into the feedback pin of a converter

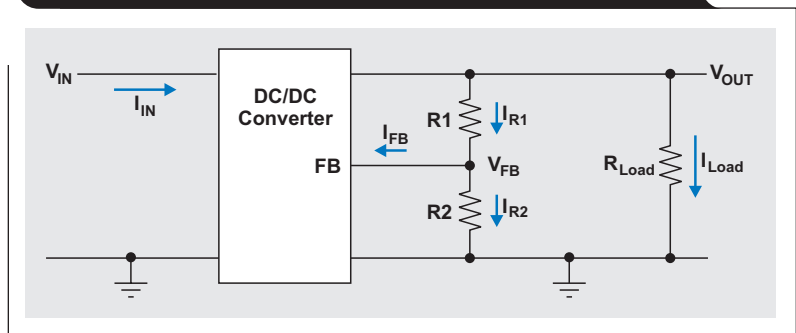

resistance (Figure 3). The voltage graphs were based on the ideal resistances required to generate an output voltage of 3.3 V with a feedback-pin voltage of 0.8 V. The only error term considered was the maximum feedback leakage current of 100 nA specified in the datasheet.

Figure 3 shows that the feedback-pin voltage decreases as the feedback-divider resistance increases. Since the feedback-pin voltage is offset, the output of the converter is also offset. At low resistances, there is no offset from the feedback-pin voltage, and the output regulates at 3.3 V as designed.

When the recommended maximum value of 400 k Ω was used for resistor R2, resulting in a total divider resistance of 1650 k Ω , the leakage current caused only a minimal decrease in the output voltage. Keeping the output voltage within the datasheet's specified accuracy is typically the reason for the datasheet to specify a maximum value for one of the resistors.

Figure 3. TPS62130's V_{FB} and V_{OUT} as functions of feedback-divider resistance

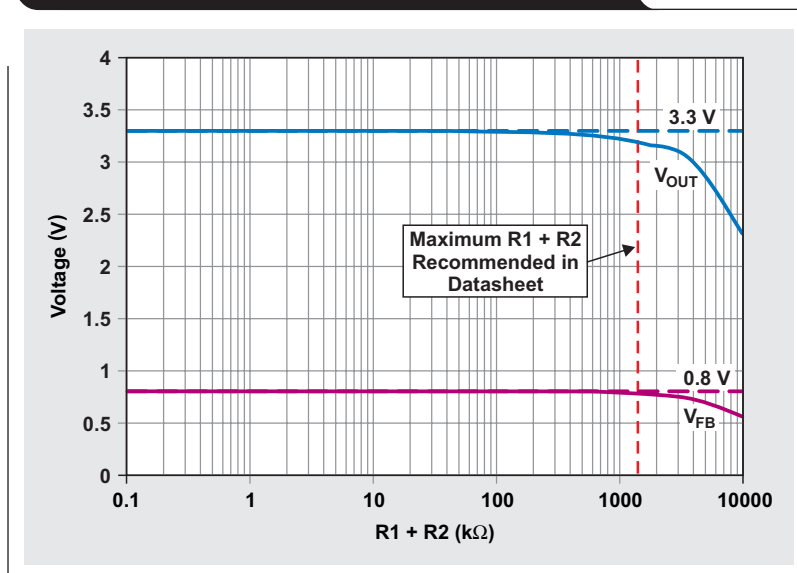

Noise sensitivity

The resistive divider is one source of noise for a converter. This noise, known as thermal noise, is equal to $4K_BTR$, where K_B is Boltzmann's constant, T is the temperature in Kelvin, and R is the resistance. Using large resistance values for the divider increases this noise.

Additionally, large resistances allow more noise to couple into the converter. This noise comes from a multitude of sources, including AM and FM radio waves, cellular phone signals, and switching converters or RF transmitters on the PCB. Noise can even come from the switching DC/DC converter itself, especially if proper PCB-layout practices are not followed. Since the resistive divider is tied to the feedback pin, the noise is amplified by the closed-loop gain of the converter and is seen at the output. To reduce the susceptibility to other noise sources, a designer might use lower feedback resistances, better board layout, or shielding. Using lower feedback resistances does reduce the noise susceptibility, though at the cost of slightly lower efficiency.

Control loop, transient response, and converter stability

A stable converter ideally has at least 45° of phase margin when measured with a network analyzer. This much phase margin gives less or no ringing on the output voltage, which prevents damage to voltage-sensitive loads during an input-voltage transient or load transient.

Depending on the control topology, the datasheet may require or recommend a feedforward capacitor (C_{FF}) to be used with the resistive feedback network. This setup is shown in Figure 4. Adding the feedforward capacitor to the resistive divider produces zero and pole frequencies that generate a phase boost capable of increasing the converter's phase margin and crossover frequency for a higher bandwidth and more stable system. Reference 2 describes this circuit in great detail. From the transfer function of the circuit in Figure 4, the zero frequency (f_z) and the pole frequency (f_p) are calculated with Equations 2 and 3, respectively:

$$f_z = \frac{1}{2\pi R1 \times C_{FF}} \quad (2)$$

Figure 4. Resistive feedback network with feedforward capacitor

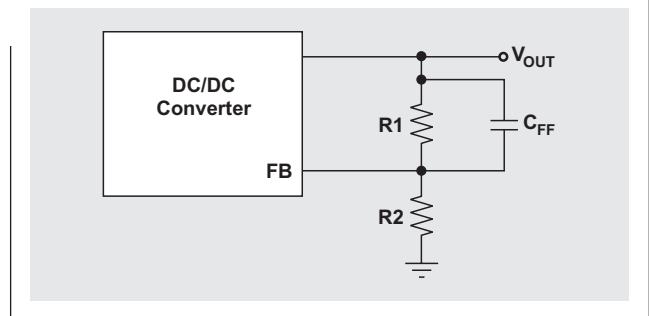

$$f_p = \frac{1}{2\pi C_{FF} \times \frac{R1 \times R2}{R1 + R2}} \quad (3)$$

Clearly, the zero and pole frequencies are functions of the values used for the resistive divider and the feedforward capacitor. Therefore, increasing or decreasing the resistance values to optimize efficiency, voltage accuracy, or noise changes the frequency location of the phase boost and the overall loop of the system. To ensure stability, Equation 4 should be used to calculate a new C_{FF} value based on the previous zero frequency or the zero frequency recommended in the datasheet (whichever value is available):

$$C_{FF}(\text{new}) = \frac{1}{2\pi R1(\text{new}) \times f_z(\text{recommended})} \text{ or} \quad (4)$$

$$\frac{1}{2\pi R1(\text{new}) \times f_z(\text{old})}$$

$$f_z(\text{old}) = \frac{1}{2\pi R1(\text{old}) \times C_{FF}(\text{old})}$$

Design example 3

The effect of the resistive divider on converter stability is seen by using a buck converter. For example 3, the TI TPS62240 buck converter was used, with $V_{IN} = 3.6$ V, $V_{OUT} = 1.8$ V, $L_{OUT} = 2.2$ μ H, $C_{OUT} = 10$ μ F, and $I_{Load} = 300$ mA.

Figures 5 and 6 respectively show the closed-loop response and its corresponding transient response under three different resistive divider networks. A feedforward capacitor was used in each network to illustrate how changing the divider-network components changes the stability of the buck converter. When the values recommended in

the datasheet for the divider-network components were used ($R1 = 365\text{ k}\Omega$, $R2 = 182\text{ k}\Omega$, and $C_{FF} = 22\text{ pF}$), the converter was stable, with a phase margin of 59° . Its transient response verified this with a slight output-voltage drop and no oscillations.

Figure 5. Buck converter's closed-loop frequency response with different R1, R2, and C_{FF} values

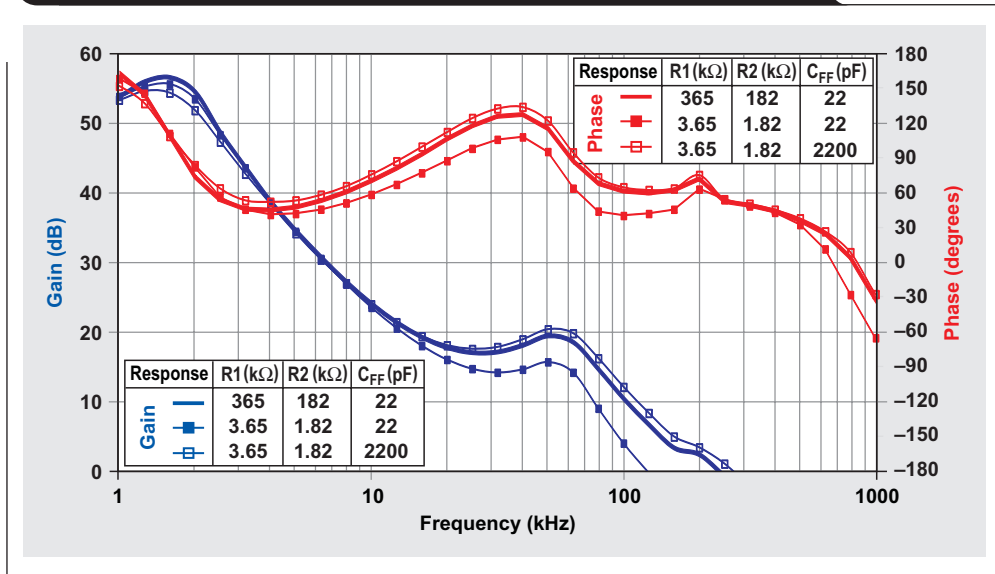
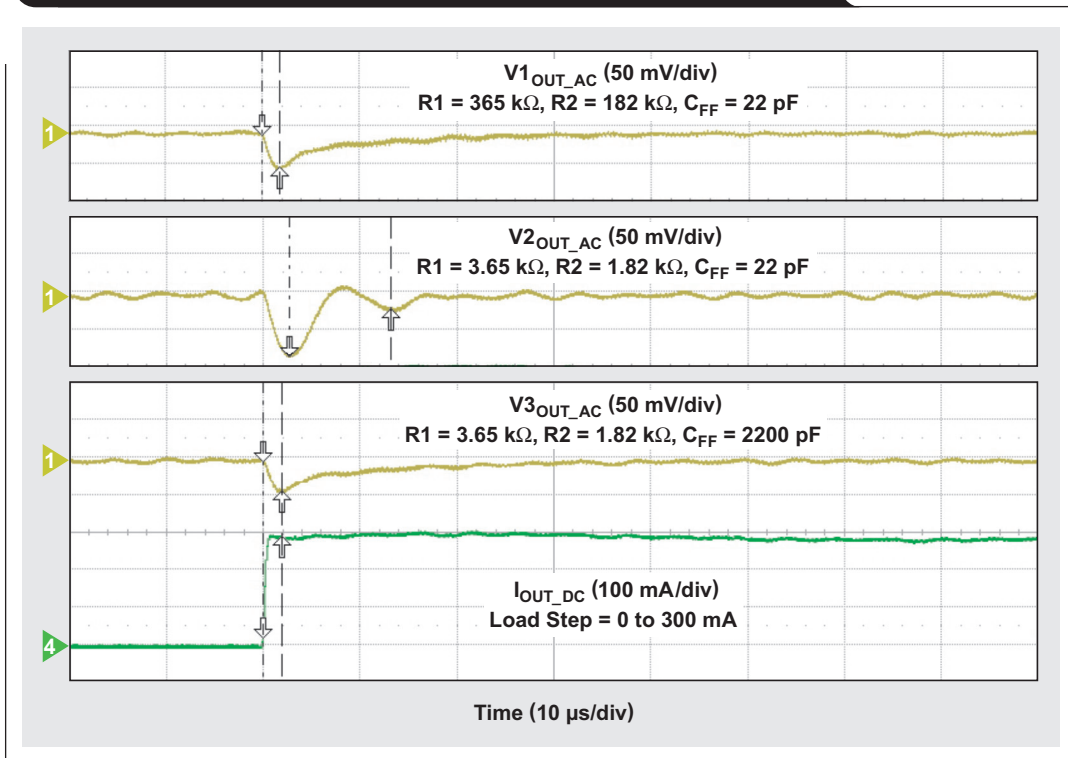

Figure 6. Buck converter's load-transient response with different R1, R2, and C_{FF} values



When the feedback-divider resistances were proportionally reduced to $R1 = 3.65 \text{ k}\Omega$ and $R2 = 1.82 \text{ k}\Omega$, but the same feedforward capacitance ($C_{FF} = 22 \text{ pF}$) was used, the change in the zero and pole frequencies of the feedback network moved the phase boost away from the crossover frequency of the loop. The frequency response showed that the converter was less stable, with a phase margin of 40° . The converter's transient response verified this with a larger output-voltage drop and more ringing. To maintain the original frequency response and stability, the C_{FF} value was recalculated for the new feedback-resistance values.

Using Equation 4 with the smaller resistance values yielded a new value for the feedforward capacitance of 2200 pF . This generated results similar to those of the first condition. The converter was stable with a phase margin of 56° , which its transient response verified with a slight output-voltage drop and no oscillation.

For a converter that utilizes a feedforward capacitor in its control topology, changing the values of the resistive divider can easily make the converter less stable. However, the example just given shows that changing these values maintains the same frequency response and transient response as long as the feedforward capacitance is adjusted appropriately.

Special-case designs

The internal compensation of some converters requires a specific C_{FF} value if a designer must use a feedforward capacitor to improve stability. For these cases, Equation 4 should not be used. Rather, the designer should use the datasheet's recommended design equations. For example, the TI TPS61070 has internal compensation across the high-side feedback resistor ($R1$). Its datasheet recommends using the following design equation for adding a capacitor in parallel to $R1$:

$$C_{FF} = 3 \text{ pF} \times \left(\frac{200 \text{ k}\Omega}{R2} - 1 \right) \tag{5}$$

Conclusion

The resistive feedback divider or network affects the efficiency, output-voltage accuracy, noise sensitivity, and stability of a DC/DC converter. To achieve the performance shown in a particular datasheet, it is important to use the datasheet's recommended values for feedback components. In other cases, system requirements may dictate departing from these recommendations to achieve some other design goal. By understanding the trade-offs between these different parameters, designers can choose larger or smaller resistances to meet their application needs.

References

For more information related to this article, you can download an Acrobat® Reader® file at www.ti.com/lit/litnumber and replace "litnumber" with the **TI Lit. #** for the materials listed below.

Document Title	TI Lit. #
1. Anthony Fagnani, "Optimizing resistor dividers at a comparator input," Application Report	SLVA450
2. Brian Butterfield, "Optimizing transient response of internally compensated dc-dc converters with feedforward capacitor," Application Report.	SLVA289

Related Web sites

power.ti.com
www.ti.com/product/partnumber
 Replace *partnumber* with TPS61070, TPS62060, TPS62130, or TPS62240

TI Worldwide Technical Support

Internet

TI Semiconductor Product Information Center Home Page

support.ti.com

TI E2E™ Community Home Page

e2e.ti.com

Product Information Centers

Americas	Phone	+1(972) 644-5580
Brazil	Phone	0800-891-2616
Mexico	Phone	0800-670-7544
	Fax	+1(972) 927-6377
	Internet/Email	support.ti.com/sc/pic/americas.htm

Europe, Middle East, and Africa

Phone	
European Free Call	00800-ASK-TEXAS (00800 275 83927)
International	+49 (0) 8161 80 2121
Russian Support	+7 (4) 95 98 10 701

Note: The European Free Call (Toll Free) number is not active in all countries. If you have technical difficulty calling the free call number, please use the international number above.

Fax	+ (49) (0) 8161 80 2045
Internet	www.ti.com/asktexas
Direct Email	asktexas@ti.com

Japan

Phone	Domestic	0120-92-3326
Fax	International	+81-3-3344-5317
	Domestic	0120-81-0036
Internet/Email	International	support.ti.com/sc/pic/japan.htm
	Domestic	www.tij.co.jp/pic

Asia

Phone	
International	+91-80-41381665
Domestic	<u>Toll-Free Number</u>
Note: Toll-free numbers do not support mobile and IP phones.	
Australia	1-800-999-084
China	800-820-8682
Hong Kong	800-96-5941
India	1-800-425-7888
Indonesia	001-803-8861-1006
Korea	080-551-2804
Malaysia	1-800-80-3973
New Zealand	0800-446-934
Philippines	1-800-765-7404
Singapore	800-886-1028
Taiwan	0800-006800
Thailand	001-800-886-0010
Fax	+8621-23073686
Email	tiasia@ti.com or ti-china@ti.com
Internet	support.ti.com/sc/pic/asia.htm

Important Notice: The products and services of Texas Instruments Incorporated and its subsidiaries described herein are sold subject to TI's standard terms and conditions of sale. Customers are advised to obtain the most current and complete information about TI products and services before placing orders. TI assumes no liability for applications assistance, customer's applications or product designs, software performance, or infringement of patents. The publication of information regarding any other company's products or services does not constitute TI's approval, warranty or endorsement thereof.

A011012

E2E is a trademark of Texas Instruments. Acrobat and Reader are registered trademarks of Adobe Systems Incorporated. All other trademarks are the property of their respective owners.

IMPORTANT NOTICE

Texas Instruments Incorporated and its subsidiaries (TI) reserve the right to make corrections, modifications, enhancements, improvements, and other changes to its products and services at any time and to discontinue any product or service without notice. Customers should obtain the latest relevant information before placing orders and should verify that such information is current and complete. All products are sold subject to TI's terms and conditions of sale supplied at the time of order acknowledgment.

TI warrants performance of its hardware products to the specifications applicable at the time of sale in accordance with TI's standard warranty. Testing and other quality control techniques are used to the extent TI deems necessary to support this warranty. Except where mandated by government requirements, testing of all parameters of each product is not necessarily performed.

TI assumes no liability for applications assistance or customer product design. Customers are responsible for their products and applications using TI components. To minimize the risks associated with customer products and applications, customers should provide adequate design and operating safeguards.

TI does not warrant or represent that any license, either express or implied, is granted under any TI patent right, copyright, mask work right, or other TI intellectual property right relating to any combination, machine, or process in which TI products or services are used. Information published by TI regarding third-party products or services does not constitute a license from TI to use such products or services or a warranty or endorsement thereof. Use of such information may require a license from a third party under the patents or other intellectual property of the third party, or a license from TI under the patents or other intellectual property of TI.

Reproduction of TI information in TI data books or data sheets is permissible only if reproduction is without alteration and is accompanied by all associated warranties, conditions, limitations, and notices. Reproduction of this information with alteration is an unfair and deceptive business practice. TI is not responsible or liable for such altered documentation. Information of third parties may be subject to additional restrictions.

Resale of TI products or services with statements different from or beyond the parameters stated by TI for that product or service voids all express and any implied warranties for the associated TI product or service and is an unfair and deceptive business practice. TI is not responsible or liable for any such statements.

TI products are not authorized for use in safety-critical applications (such as life support) where a failure of the TI product would reasonably be expected to cause severe personal injury or death, unless officers of the parties have executed an agreement specifically governing such use. Buyers represent that they have all necessary expertise in the safety and regulatory ramifications of their applications, and acknowledge and agree that they are solely responsible for all legal, regulatory and safety-related requirements concerning their products and any use of TI products in such safety-critical applications, notwithstanding any applications-related information or support that may be provided by TI. Further, Buyers must fully indemnify TI and its representatives against any damages arising out of the use of TI products in such safety-critical applications.

TI products are neither designed nor intended for use in military/aerospace applications or environments unless the TI products are specifically designated by TI as military-grade or "enhanced plastic." Only products designated by TI as military-grade meet military specifications. Buyers acknowledge and agree that any such use of TI products which TI has not designated as military-grade is solely at the Buyer's risk, and that they are solely responsible for compliance with all legal and regulatory requirements in connection with such use.

TI products are neither designed nor intended for use in automotive applications or environments unless the specific TI products are designated by TI as compliant with ISO/TS 16949 requirements. Buyers acknowledge and agree that, if they use any non-designated products in automotive applications, TI will not be responsible for any failure to meet such requirements.

Following are URLs where you can obtain information on other Texas Instruments products and application solutions:

Products

Audio	www.ti.com/audio
Amplifiers	amplifier.ti.com
Data Converters	dataconverter.ti.com
DLP® Products	www.dlp.com
DSP	dsp.ti.com
Clocks and Timers	www.ti.com/clocks
Interface	interface.ti.com
Logic	logic.ti.com
Power Mgmt	power.ti.com
Microcontrollers	microcontroller.ti.com
RFID	www.ti-rfid.com
OMAP Mobile Processors	www.ti.com/omap
Wireless Connectivity	www.ti.com/wirelessconnectivity

Applications

Automotive and Transportation	www.ti.com/automotive
Communications and Telecom	www.ti.com/communications
Computers and Peripherals	www.ti.com/computers
Consumer Electronics	www.ti.com/consumer-apps
Energy and Lighting	www.ti.com/energy
Industrial	www.ti.com/industrial
Medical	www.ti.com/medical
Security	www.ti.com/security
Space, Avionics and Defense	www.ti.com/space-avionics-defense
Video and Imaging	www.ti.com/video

TI E2E Community Home Page

e2e.ti.com

Mailing Address: Texas Instruments, Post Office Box 655303, Dallas, Texas 75265
Copyright © 2012, Texas Instruments Incorporated