

AN-1256 Tiny Temperature Sensors for Portable Systems

ABSTRACT

The last year has seen the introduction of silicon temperature sensors in revolutionary small packages, ideal for portable systems. This application report discusses trade-offs in accuracy, as well as how to choose between thermistors and analog output IC temperature sensors.

Contents

1	Tiny Temperature Sensors for Portable Systems	2
---	---	---

List of Figures

1	Comparison of Analog Temperature Sensors to Thermistors	2
2	Connecting a Thermistor or an LM20 to an Analog-to-Digital Converter (ADC).....	2
3	Thermistor Output Voltage Versus Temperature for Different Values of R	3
4	Comparison of Thermistor to LM20 System Performance	4

1 Tiny Temperature Sensors for Portable Systems

Figure 1 shows the output voltage transfer function of various analog output temperature sensors. These sensors are available in tiny packages like the SC70 and the 4-bump micro SMD. The LM20 is the smallest, lowest power (10 μ A max) analog output temperature sensor Texas Instruments has released and is available in the SC70 and micro SMD packages. The LM70 and LM74 are MICROWIRE/SPI compatible digital temperature sensors and are available in the LLP and 8-bump micro SMD packages, respectively. The LM70 and LM74 have resolutions of 0.125°C and 0.0625°C, respectively. The LM74 is the most accurate of the two, with an accuracy of better than $\pm 1.25^\circ\text{C}$.

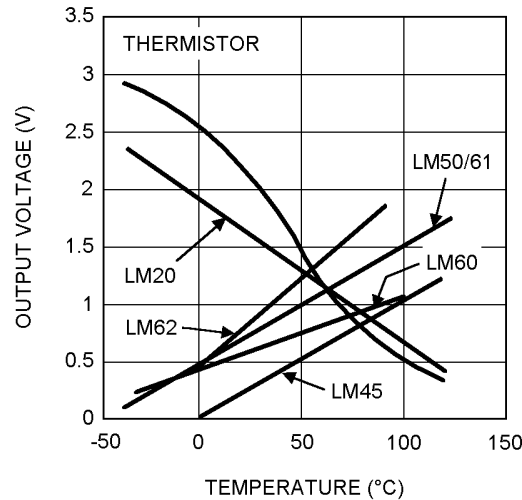

Figure 1. Comparison of Analog Temperature Sensors to Thermistors

The curves shown in Figure 1 compare the temperature-to-voltage transfer functions of silicon temperature sensors with that of an NTC thermistor.

Thermistors come in a variety of packages ranging from probes to beads. However, ICs have surface mount packaging equivalent to thermistors, as in the LM20 micro SMD.

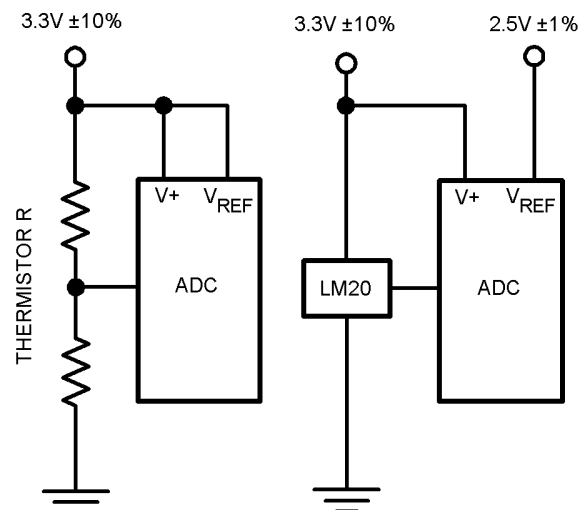

Figure 2. Connecting a Thermistor or an LM20 to an Analog-to-Digital Converter (ADC)

Thermistors, when biased ratiometrically (as shown in Figure 2), have the advantage of not requiring an accurate or stable voltage reference in the system. In ratiometric operation, the error introduced by the reference is cancelled out. If ratiometric operation is not possible, for instance when the ADC reference voltage is in an ASIC and is not pinned out, using ICs like the LM20 result in better total system accuracy. The LM20 draws only 10 μA of current while the current drawn by the thermistor circuit depend on the value of R.

A specific thermistor was analyzed: the Murata NTH5G10P/16P33B103F. This thermistor has an accuracy of 1% at 25°C. The evaluation used ADCs with various resolutions to examine the overall system accuracy that depends on the resolution of the ADC, the ADC's errors (gain, offset and nonlinearity or TUE, total unadjusted error) and the resolution of the compensation table.

Figure 3 shows the voltage applied at the ADC input for the thermistor circuit shown in Figure 2. Note that the ADC input voltage decreases logarithmically with increasing temperature. The 97.6k resistor optimizes the power dissipation (30 μA) in the thermistor. It allows the thermistor to operate at a power level not exceeding its maximum power rating while maintaining specified accuracy.

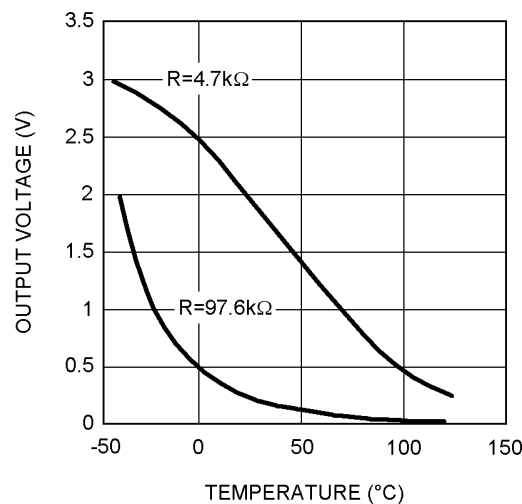

Figure 3. Thermistor Output Voltage Versus Temperature for Different Values of R

Lowering the value of R increases the temperature range over which the thermistor's transfer function is linear. With a 4.7k bias resistor, the slope at higher temperatures increases, providing more resolution, at the cost of greater power consumption (600 μA)

Figure 4 compares the overall system accuracy when using a thermistor with an 8-bit ADC and R=100k, a thermistor with a 10-bit ADC and R=33k, or an LM20 with an 8-bit ADC. The quantization error and ADC total unadjusted error (a combination of offset, gain and linearity errors) was considered to determine the overall system accuracy. The black lines show the min/max system performance of the LM20 superimposed over the blue min/max performance of the thermistor. The overall system accuracy for the LM20 remains constant over temperature. At temperatures above 60°C, the LM20 wins big when compared to the performance of the thermistor and 8-bit ADC.

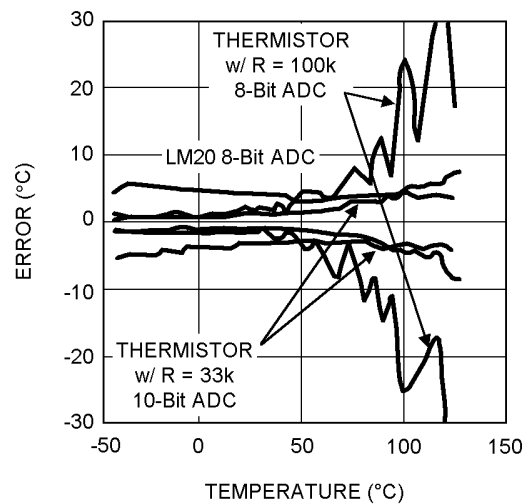

Figure 4. Comparison of Thermistor to LM20 System Performance

Increasing the ADC resolution and decreasing the value of R in the thermistor circuit decreases the overall system error. Improving the accuracy of the voltage reference brings the LM20 system accuracy closer to that of the specifications found on the LM20 data sheet of $\pm 2.5^{\circ}\text{C}$ at $+130^{\circ}\text{C}$ and -55°C , and $\pm 1.5^{\circ}\text{C}$ at $+30^{\circ}\text{C}$. Since the output slope of the LM20 is negative, the gain error introduced by the reference voltage plays less of a role in the overall accuracy as the temperature increases, thus the slight negative slope of the LM20 performance.

Designers have numerous options for sensing temperature. Most common are thermistors, RTDs, thermocouples, and active silicon sensors. IC sensors have major advantages when the temperatures to be measured fall within the normal operating temperature range of silicon ICs. Among these advantages are low system cost, small size, and fast design time (because external signal conditioning circuitry is either minimal or not required). ICs can include extensive additional functions, such as built-in trip-point comparators or digital I/O. Since they include on-chip linearity correction when needed, there is no need for lookup tables to correct linearity errors.

IMPORTANT NOTICE

Texas Instruments Incorporated and its subsidiaries (TI) reserve the right to make corrections, enhancements, improvements and other changes to its semiconductor products and services per JESD46, latest issue, and to discontinue any product or service per JESD48, latest issue. Buyers should obtain the latest relevant information before placing orders and should verify that such information is current and complete. All semiconductor products (also referred to herein as "components") are sold subject to TI's terms and conditions of sale supplied at the time of order acknowledgment.

TI warrants performance of its components to the specifications applicable at the time of sale, in accordance with the warranty in TI's terms and conditions of sale of semiconductor products. Testing and other quality control techniques are used to the extent TI deems necessary to support this warranty. Except where mandated by applicable law, testing of all parameters of each component is not necessarily performed.

TI assumes no liability for applications assistance or the design of Buyers' products. Buyers are responsible for their products and applications using TI components. To minimize the risks associated with Buyers' products and applications, Buyers should provide adequate design and operating safeguards.

TI does not warrant or represent that any license, either express or implied, is granted under any patent right, copyright, mask work right, or other intellectual property right relating to any combination, machine, or process in which TI components or services are used. Information published by TI regarding third-party products or services does not constitute a license to use such products or services or a warranty or endorsement thereof. Use of such information may require a license from a third party under the patents or other intellectual property of the third party, or a license from TI under the patents or other intellectual property of TI.

Reproduction of significant portions of TI information in TI data books or data sheets is permissible only if reproduction is without alteration and is accompanied by all associated warranties, conditions, limitations, and notices. TI is not responsible or liable for such altered documentation. Information of third parties may be subject to additional restrictions.

Resale of TI components or services with statements different from or beyond the parameters stated by TI for that component or service voids all express and any implied warranties for the associated TI component or service and is an unfair and deceptive business practice. TI is not responsible or liable for any such statements.

Buyer acknowledges and agrees that it is solely responsible for compliance with all legal, regulatory and safety-related requirements concerning its products, and any use of TI components in its applications, notwithstanding any applications-related information or support that may be provided by TI. Buyer represents and agrees that it has all the necessary expertise to create and implement safeguards which anticipate dangerous consequences of failures, monitor failures and their consequences, lessen the likelihood of failures that might cause harm and take appropriate remedial actions. Buyer will fully indemnify TI and its representatives against any damages arising out of the use of any TI components in safety-critical applications.

In some cases, TI components may be promoted specifically to facilitate safety-related applications. With such components, TI's goal is to help enable customers to design and create their own end-product solutions that meet applicable functional safety standards and requirements. Nonetheless, such components are subject to these terms.

No TI components are authorized for use in FDA Class III (or similar life-critical medical equipment) unless authorized officers of the parties have executed a special agreement specifically governing such use.

Only those TI components which TI has specifically designated as military grade or "enhanced plastic" are designed and intended for use in military/aerospace applications or environments. Buyer acknowledges and agrees that any military or aerospace use of TI components which have **not** been so designated is solely at the Buyer's risk, and that Buyer is solely responsible for compliance with all legal and regulatory requirements in connection with such use.

TI has specifically designated certain components as meeting ISO/TS16949 requirements, mainly for automotive use. In any case of use of non-designated products, TI will not be responsible for any failure to meet ISO/TS16949.

Products

Audio	www.ti.com/audio
Amplifiers	amplifier.ti.com
Data Converters	dataconverter.ti.com
DLP® Products	www.dlp.com
DSP	dsp.ti.com
Clocks and Timers	www.ti.com/clocks
Interface	interface.ti.com
Logic	logic.ti.com
Power Mgmt	power.ti.com
Microcontrollers	microcontroller.ti.com
RFID	www.ti-rfid.com
OMAP Applications Processors	www.ti.com/omap
Wireless Connectivity	www.ti.com/wirelessconnectivity

Applications

Automotive and Transportation	www.ti.com/automotive
Communications and Telecom	www.ti.com/communications
Computers and Peripherals	www.ti.com/computers
Consumer Electronics	www.ti.com/consumer-apps
Energy and Lighting	www.ti.com/energy
Industrial	www.ti.com/industrial
Medical	www.ti.com/medical
Security	www.ti.com/security
Space, Avionics and Defense	www.ti.com/space-avionics-defense
Video and Imaging	www.ti.com/video

TI E2E Community

e2e.ti.com