

# DS36954

*Application Note 904 An Introduction to the Differential SCSI Interface*



Literature Number: SNLA033

# An Introduction to the Differential SCSI Interface

National Semiconductor  
Application Note 904  
John Goldie  
August 1993



## OVERVIEW

The scope of this application note is to provide an introduction to the SCSI Parallel Interface and insight into the differential option specified by the SCSI standards. This application covers the following topics:

- The SCSI Interface
- Why Differential SCSI?
- The SCSI Bus
- SCSI Bus States
- SCSI Options: Fast and Wide
- The SCSI Termination
- SCSI Controller Requirements
- Summary of SCSI Standards
- References/Standards

## THE SCSI INTERFACE

The Small Computer System Interface is an ANSI (American National Standards Institute) interface standard defining a peer to peer generic input/output bus (I/O bus). The intention of the SCSI standard is to provide a fast, multipoint parallel bus that is easily upgradeable and keeps pace with advancing technologies.

The SCSI interface is commonly the interconnect of choice for high performance hard disk drives. Being a generic interface, the SCSI bus is not limited to only one type of peripheral. It is also commonly used to interconnect optical drives, tape drives, disk arrays, scanners, printers, and other targets to a wide range of terminals, computers, and other hosts. It is important to also remember that a SCSI bus is not a point to point bus, but rather a multipoint bus, allowing up to eight

different devices to be connected to the same daisy chained cable (SCSI-1 and 2 allows up to eight devices while the proposed SCSI-3 standard will allow up to 32 devices). A typical SCSI bus configuration is shown in *Figure 1*.

## WHY DIFFERENTIAL SCSI?

In comparison to single-ended SCSI, differential SCSI costs more and has additional power and PC board space requirements. However, the gained benefits are well worth the additional IC cost, PCB space, and required power in many applications. Differential SCSI provides the following benefits over single-ended SCSI:

• **Reliable High Transfer Rates** — easily capable of operating at 10MT/s (Fast SCSI) without special attention to terminations. Even higher data rates are currently being standardized (FAST-20 @ 20MT/s).

The companion Application Note (AN-905) focuses on the features of National's new RS-485 hex transceiver. The DS36BC956 specifically designed for use in differential SCSI applications is also optimal for use in other high speed, parallel, multipoint applications.

• **High Noise Rejection** — the differential transmission scheme provides excellent common mode rejection over a wide bus voltage range.

• **Long Cable Lengths** — cables can be as long as 25 meters in length compared to 3 meters or less for single-ended interfaces.

• **Superior AC Performance** — high performance transceivers with tightly specified and guaranteed AC performance.

• **Fault Tolerance** — current limiting and thermal shutdown protection integrated into the differential driver design.

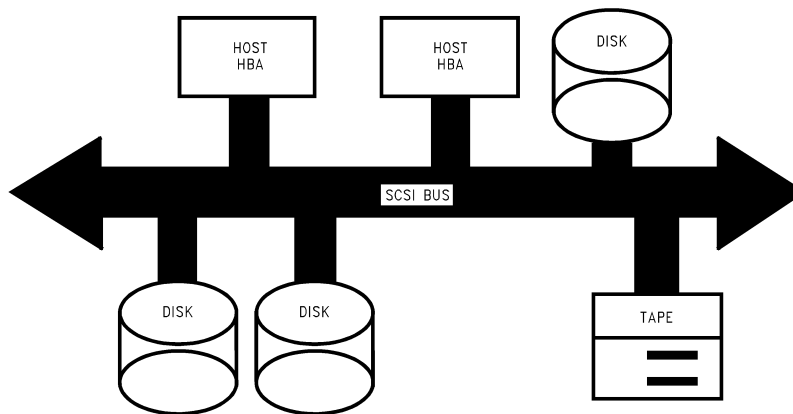

AN011897-1

FIGURE 1. Typical SCSI Bus Configuration-Multiple Hosts/Multiple Targets

Signal quality and long cable runs are the two major enhancements differential SCSI offers over single-ended SCSI. As stated above, differential SCSI allows for cable runs up to

25 meters in length compared to only 3 meters of single-ended SCSI. Differential SCSI is optimal for connecting together terminals with storage arrays located in a sepa-

rate cooled computer room. The differential transmission scheme offers superior noise rejection and signal quality compared to a TTL single-ended bus.

Differential buses are also immune to minor termination problems that commonly plague the single-ended SCSI bus. These problems can, and commonly do have major impact on single-ended system performance. By expanding the cable length beyond 3 meters, by mixing different cable types (impedance), by using different types of termination, or by using the standard passive termination, system throughput may be reduced as great as 50%. Since it has been determined that the original single-ended termination recommended in the SCSI-1 standard does not provide adequate signal termination performance for Fast SCSI, the SCSI-2 and proposed SCSI-3 standards recommend the use of alternate terminations. There are three popular alternatives to the passive resistive terminators. These are the Boulay termination (voltage regulated), Current Regulated Terminations, and the FPT (forced perfect termination). Each has its own merits and limitations, and in fact the FPT offers good performance but is not sanctioned by the standard. Trouble can arise in single-ended SCSI applications when different types of termination are used on the bus. In addition, some SCSI controllers now provide totem pole outputs on the high speed lines (REQ and ACK) to improve the signal quality on those lines on the de-assert edge (active negation in industry jargon). These active negation drivers can become in contention with the alternative termination techniques and cause thermal problems and data corruption. Single-ended SCSI termination have caused much grief, and discussion in the SCSI standard committee.

In contrast Differential SCSI has not encountered the problems that drove the single-ended interface to develop so many alternative terminations. Differential SCSI uses a standard passive resistor termination (described in detail later in this application note). This terminator remains unchanged from the original SCSI-1 standard to the proposed SCSI-3 physical layer.

National's DS36954 Quad Differential Bus Transceiver is designed for Differential SCSI applications up to 10 MT/s.

#### THE SCSI BUS

The SCSI bus is composed of a minimum of 18 signal lines. An option is provided to add extra bytes to boost system throughput (Mega Bytes per second (MB/s)) if required by

the application. The SCSI 1 and 2 standards define two types of electrical characteristics; single-ended and differential.

Single-ended drivers (typically 48 mA open drain drivers) and receivers are commonly integrated onto the SCSI controller chips. For the differential option, external RS-485 transceivers are required. Integrating the differential transceivers onto the SCSI controller is not feasible due to the additional pins required for differential operation, and the additional power dissipation. Additionally the semiconductor processes commonly used for the controllers are not compatible with the special high speed/high voltage breakdown processes used for RS-485 transceivers.

The single-ended and differential modes are exclusive, and can not inter-operate. Of the 18 lines, 9 are data path (data plus parity) and the others are control. The lines are:

- Data Path
  - DB(7-0,P)— Data Bus
- Control
  - REQ— Request
  - ACK— Acknowledge
  - BSY— Busy
  - SEL— Select
  - C/D— Control/Data
  - I/O— Input/Output
  - MSG— Message
  - ATN— Attention
  - RST— Reset

The SCSI Standard has two types of devices, which are "Initiators" (typically a host computer); and "Targets" (typically drives). Of the 18 lines, 9 are bi-directional, 7 are uni-directional direction, and 2 are wire-ORed. The data bus (DB0-DB7 and DBP) are the bi-directional lines. Three control lines are Initiator to Target only lines; these are the ACK, ATN, and SEL\* lines. Four lines are Target to Initiator only lines; these are the C/D, I/O, REQ, and MSG lines. A pictorial representation of the signal lines is shown in *Figure 2*.

(\* SEL can also be a wire-ORed line, but is more commonly implemented as a initiator to target line).

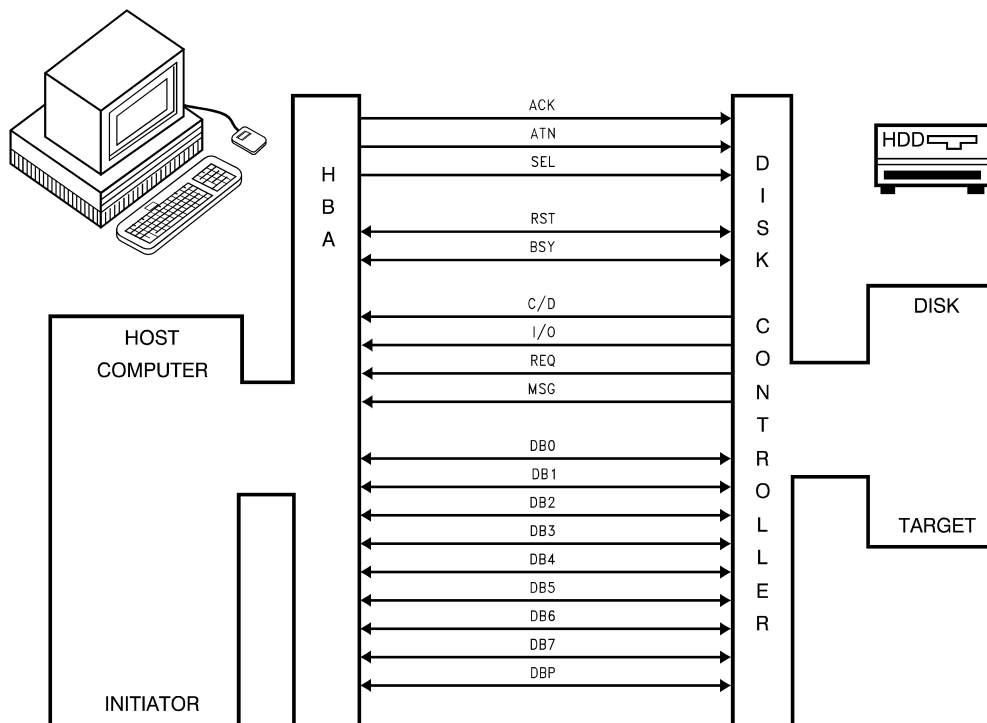

AN011897-2

FIGURE 2. The SCSI Signal Lines

Of the 18 lines, two, REQ and ACK, can operate at switching rates up to 10 MHz. They are defined as handshake lines, that in the asynchronous mode, strobe every byte of data. The maximum defined data transfer rate is 10MT/s for Fast SCSI. This corresponds to a bit width of 100 ns. The data path bits are the second fastest lines on the SCSI bus operating at 10MT/s maximum (5 MHz maximum for a 1-0-1-0 pattern). The other control lines are low speed lines and are level sensitive not edge sensitive. These lines typically only switch between bus states, and a substantial amount of time is provided for settling.

#### SCSI BUS STATES

The SCSI bus has eight different states which are:

- BUS FREE
- ARBITRATION
- SELECTION
- RESELECTION
- COMMAND
- DATA
- STATUS
- MESSAGE

The SCSI bus state is determined by the state of the SEL, BSY, I/O, MSG, and C/D control lines. Initiators are in control of the bus up to the command phase, and targets control the last three information transfer phases. For example when SEL and BSY are both false, the SCSI bus is in a bus free state.

#### SCSI OPTIONS: FAST AND WIDE

The FAST option allows for operation at 10MT/s (Mega Transfers per second) compared to the original 5MT/s specified in the original SCSI standard (now commonly referred to as SCSI-1). Single-ended drivers and receivers should be limited to cables less than 3 meters in length and be properly terminated. In contrast, the differential RS-485 transceivers can operate at 10MT/s over 25 meters of cable and due to the differential scheme, offer high noise rejection. The SCSI-2 (draft, 1993) introduced this option to SCSI and has gained wide acceptance.

The WIDE option (also introduced in the SCSI-2 specification) defines extra lines that double or quadruple the system throughput (MB/s). Adding a second byte of data can be accomplished in two different ways. First, one could select the P cable which, with 68 conductors can house both bytes of data and the nine control lines (for a total of 27 lines). The other option specifies two cables (A and B); the A for the first byte and the nine control lines, while the B cable carries the second byte plus an additional REQ and ACK line (for a total of 29 lines). Since the second option requires two sets of connectors and cables, the P cable has become the more popular of the two, as it saves money and back panel space. The P cable (and Q for Byte 3 and 4) is included in the SCSI-3 Parallel Interface (known as SPI) draft standard, however A and B 50-pin cables are also still allowed. With two bytes of data being transferred, 20MB/s is obtainable.

Four bytes achieves a 40MB/s maximum transfer rate. However, the four byte option is not very popular since it again requires two cables (P and Q).

### THE SCSI TERMINATION

The differential SCSI bus requires line termination at both ends of the cable. Unlike the single-ended SCSI option, only one type of termination is defined. The line is terminated with a 3 resistor network commonly called a power termination. The three resistors are: 330Ω between the -Signal and the termination voltage (+5V), 150Ω between the signal pair (-Signal and +Signal), and 330Ω from +Signal to ground. The equivalent resistance of this network is 122Ω ( $150\Omega // (330\Omega + 330\Omega)$ ), and closely approximates the characteristic impedance ( $Z_0$ ) of the defined cable. The termination network is shown in Figure 3.

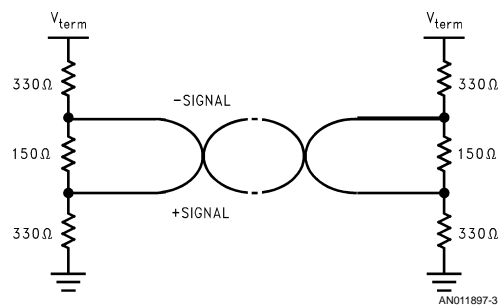

FIGURE 3. The SCSI Differential Termination

By using this termination reflections are minimized and a fail-safe bias is provided. When all drivers are in TRI-STATE® (OFF), the resistors bias the line to approximately -1V differential. The SCSI standard defines this as a FALSE state or not-asserted. The minus sign comes from the fact that the +Signal is less in potential than the -Signal by one volt. It does not imply that the voltage is one volt below ground. A common problem that occurs when installing SCSI networks is employing greater than two termination networks. Devices connected in the middle of the bus should not include (enabled) termination networks. The termination networks should only be located at the extreme ends of the cable. Installing three or more terminations loads down the driver's output signal and reduces or eliminates the noise margin.

### SCSI CONTROLLER REQUIREMENTS

Not all SCSI controllers support the differential mode. This is due to the fact that the external transceivers require direction control signals.

### SUMMARY OF SCSI STANDARDS

This application note provides an introduction and brief overview of the differential option for the SCSI parallel interface. The reader is referenced to the standards listed below for complete, current SCSI specifications. Also, a number of SCSI handbooks are available that cover SCSI basics and protocol details written in plain English compared to the more encrypted standards.

Various manufactures reference different version of the SCSI standard. This creates some confusion to new users. The original version of SCSI released in 1986 is commonly referred to as SCSI or SCSI-1. The ANSI committee has created the second edition of SCSI known as SCSI-2, which is currently in industry ballot (1993). This is still a draft standard until balloting is complete. Approval should occur some time in 1993. Work has started on SCSI-3 also. This proposed standard was broken down into many smaller standards to speed up the ballot/approval process. The parallel interface standard is specified in the SPI document (SCSI Parallel Interface). SCSI-3 differs from SCSI-1 and -2 in the fact that it also specifies alternate physical layers. Currently a serial bus based on a proposed IEEE standard (P1394) is being standardized for small form factor drives and also a fiber physical layer. Table 1 describes some of the major differences in the physical layers in SCSI-1, 2, and 3 standard and draft standards.

TABLE 1. SCSI Standard Comparison

Parameter	SCSI-1	SCSI-2	SCSI-3
Maximum Nodes	8	8	8, 16, and 32
Fast SCSI	NO	YES	YES
Wide SCSI	NO	YES	YES
Maximum Transfer Rate	5MT/s	10MT/s	10MT/s
MB/s-1 Byte	5	10	10
MB/s-2 Byte	X	20	20
MB/s-4 Byte	X	40	40
Document	X3.131 -1986	X3.131 -199x	SPI draft

### REFERENCES/STANDARDS

Electrical Characteristics of Generators and Receivers for use in Balanced Digital Multipoint Systems, EIA RS-485-1983, TIA/EIA  
 Small Computer System Interface (SCSI-1), X3.131-1986, ANSI  
 Small Computer System Interface (SCSI-2), X3.131-199x, ANSI  
 SCSI-3 Parallel Interface (SPI), X3T9.2/91-010, Draft Standard, ANSI





**LIFE SUPPORT POLICY**

NATIONAL'S PRODUCTS ARE NOT AUTHORIZED FOR USE AS CRITICAL COMPONENTS IN LIFE SUPPORT DEVICES OR SYSTEMS WITHOUT THE EXPRESS WRITTEN APPROVAL OF THE PRESIDENT OF NATIONAL SEMICONDUCTOR CORPORATION. As used herein:

1. Life support devices or systems are devices or systems which, (a) are intended for surgical implant into the body, or (b) support or sustain life, and whose failure to perform when properly used in accordance with instructions for use provided in the labeling, can be reasonably expected to result in a significant injury to the user.
2. A critical component in any component of a life support device or system whose failure to perform can be reasonably expected to cause the failure of the life support device or system, or to affect its safety or effectiveness.

 <b>National Semiconductor Corporation</b> Americas Tel: 1-800-272-9959 Fax: 1-800-737-7018 Email: support@nsc.com  www.national.com	<b>National Semiconductor Europe</b> Fax: +49 (0) 1 80-530 85 86 Email: europe.support@nsc.com Deutsch Tel: +49 (0) 1 80-530 85 85 English Tel: +49 (0) 1 80-532 78 32 Français Tel: +49 (0) 1 80-532 93 58 Italiano Tel: +49 (0) 1 80-534 16 80	<b>National Semiconductor Asia Pacific Customer Response Group</b> Tel: 65-2544466 Fax: 65-2504466 Email: sea.support@nsc.com	<b>National Semiconductor Japan Ltd.</b> Tel: 81-3-5620-6175 Fax: 81-3-5620-6179
--	--	--	--

National does not assume any responsibility for use of any circuitry described, no circuit patent licenses are implied and National reserves the right at any time without notice to change said circuitry and specifications.

## IMPORTANT NOTICE

Texas Instruments Incorporated and its subsidiaries (TI) reserve the right to make corrections, modifications, enhancements, improvements, and other changes to its products and services at any time and to discontinue any product or service without notice. Customers should obtain the latest relevant information before placing orders and should verify that such information is current and complete. All products are sold subject to TI's terms and conditions of sale supplied at the time of order acknowledgment.

TI warrants performance of its hardware products to the specifications applicable at the time of sale in accordance with TI's standard warranty. Testing and other quality control techniques are used to the extent TI deems necessary to support this warranty. Except where mandated by government requirements, testing of all parameters of each product is not necessarily performed.

TI assumes no liability for applications assistance or customer product design. Customers are responsible for their products and applications using TI components. To minimize the risks associated with customer products and applications, customers should provide adequate design and operating safeguards.

TI does not warrant or represent that any license, either express or implied, is granted under any TI patent right, copyright, mask work right, or other TI intellectual property right relating to any combination, machine, or process in which TI products or services are used. Information published by TI regarding third-party products or services does not constitute a license from TI to use such products or services or a warranty or endorsement thereof. Use of such information may require a license from a third party under the patents or other intellectual property of the third party, or a license from TI under the patents or other intellectual property of TI.

Reproduction of TI information in TI data books or data sheets is permissible only if reproduction is without alteration and is accompanied by all associated warranties, conditions, limitations, and notices. Reproduction of this information with alteration is an unfair and deceptive business practice. TI is not responsible or liable for such altered documentation. Information of third parties may be subject to additional restrictions.

Resale of TI products or services with statements different from or beyond the parameters stated by TI for that product or service voids all express and any implied warranties for the associated TI product or service and is an unfair and deceptive business practice. TI is not responsible or liable for any such statements.

TI products are not authorized for use in safety-critical applications (such as life support) where a failure of the TI product would reasonably be expected to cause severe personal injury or death, unless officers of the parties have executed an agreement specifically governing such use. Buyers represent that they have all necessary expertise in the safety and regulatory ramifications of their applications, and acknowledge and agree that they are solely responsible for all legal, regulatory and safety-related requirements concerning their products and any use of TI products in such safety-critical applications, notwithstanding any applications-related information or support that may be provided by TI. Further, Buyers must fully indemnify TI and its representatives against any damages arising out of the use of TI products in such safety-critical applications.

TI products are neither designed nor intended for use in military/aerospace applications or environments unless the TI products are specifically designated by TI as military-grade or "enhanced plastic." Only products designated by TI as military-grade meet military specifications. Buyers acknowledge and agree that any such use of TI products which TI has not designated as military-grade is solely at the Buyer's risk, and that they are solely responsible for compliance with all legal and regulatory requirements in connection with such use.

TI products are neither designed nor intended for use in automotive applications or environments unless the specific TI products are designated by TI as compliant with ISO/TS 16949 requirements. Buyers acknowledge and agree that, if they use any non-designated products in automotive applications, TI will not be responsible for any failure to meet such requirements.

Following are URLs where you can obtain information on other Texas Instruments products and application solutions:

### Products

Audio	<a href="http://www.ti.com/audio">www.ti.com/audio</a>
Amplifiers	<a href="http://amplifier.ti.com">amplifier.ti.com</a>
Data Converters	<a href="http://dataconverter.ti.com">dataconverter.ti.com</a>
DLP® Products	<a href="http://www.dlp.com">www.dlp.com</a>
DSP	<a href="http://dsp.ti.com">dsp.ti.com</a>
Clocks and Timers	<a href="http://www.ti.com/clocks">www.ti.com/clocks</a>
Interface	<a href="http://interface.ti.com">interface.ti.com</a>
Logic	<a href="http://logic.ti.com">logic.ti.com</a>
Power Mgmt	<a href="http://power.ti.com">power.ti.com</a>
Microcontrollers	<a href="http://microcontroller.ti.com">microcontroller.ti.com</a>
RFID	<a href="http://www.ti-rfid.com">www.ti-rfid.com</a>
OMAP Mobile Processors	<a href="http://www.ti.com/omap">www.ti.com/omap</a>
Wireless Connectivity	<a href="http://www.ti.com/wirelessconnectivity">www.ti.com/wirelessconnectivity</a>

### Applications

Communications and Telecom	<a href="http://www.ti.com/communications">www.ti.com/communications</a>
Computers and Peripherals	<a href="http://www.ti.com/computers">www.ti.com/computers</a>
Consumer Electronics	<a href="http://www.ti.com/consumer-apps">www.ti.com/consumer-apps</a>
Energy and Lighting	<a href="http://www.ti.com/energy">www.ti.com/energy</a>
Industrial	<a href="http://www.ti.com/industrial">www.ti.com/industrial</a>
Medical	<a href="http://www.ti.com/medical">www.ti.com/medical</a>
Security	<a href="http://www.ti.com/security">www.ti.com/security</a>
Space, Avionics and Defense	<a href="http://www.ti.com/space-avionics-defense">www.ti.com/space-avionics-defense</a>
Transportation and Automotive	<a href="http://www.ti.com/automotive">www.ti.com/automotive</a>
Video and Imaging	<a href="http://www.ti.com/video">www.ti.com/video</a>

TI E2E Community Home Page

[e2e.ti.com](http://e2e.ti.com)

Mailing Address: Texas Instruments, Post Office Box 655303, Dallas, Texas 75265  
Copyright © 2011, Texas Instruments Incorporated