

***Live Insertion with BTL Transceivers***



Literature Number: SNLA161

# Live Insertion with BTL Transceivers

National Semiconductor  
 Application Note 834  
 Joel Martinez  
 Stephen Kempainen  
 July 1992



Live Insertion with BTL Transceivers

This paper investigates the possible glitches caused by inserting a board or module into a powered Futurebus+ backplane. The signal lines on the backplane will be in one of three states; high—when the bus is released, low—when the bus is asserted, and the transition state. In the transition state the bus will be going from a high to a low state or vice versa. The bus will spend the majority of the time in the high or low state. The glitch during live insertion will be investigated for the high and low state.

The LI (live insertion) pin on the Futurebus+ Transceivers helps minimize the loading on the bus during live insertion and after the board has been plugged into the backplane.

When LI is connected to  $V_{CC}$  and the output is in the released state, the output Schottky diode (DS2) remains reversed biased thereby minimizing the output capacitance as shown below. Reducing the capacitance at the output will minimize bus loading.

The measurements were taken from a 10 slot backplane with 1" slot to slot spacing. The lines were terminated with  $39\Omega$  resistors to 2.1V at each end. This is not a Profile A/B/F compliant Futurebus+ backplane. A standard backplane will have 30 mm (1¼") slot to slot spacing, 14 slots and  $33\Omega$  terminations. The board was provided by Hybricon and uses the DS3884A Futurebus+ 6-bit transceiver offered by National Semiconductor. The live insertion glitch taken on this backplane will be similar if taken on a standard Futurebus+ backplane. The measurements were taken directly on the backplane (the rear side of the backplane was probed using a high impedance 2 GHz scope) unless otherwise specified.

The Futurebus+ backplane has two stages of contact. Stage one is when the power pins between the board and the backplane mate. Stage two is when the rest of the signal pins make contact. These two stages are implemented by having short signal pins and long power pins on the backplane. As the board is inserted into the backplane the backplane power pins (VBP and ground) make contact with the board sooner than the signal pins as shown on *Figure 1*. Stage two, when the signal pins make contact with the backplane, will be the subject of this paper.

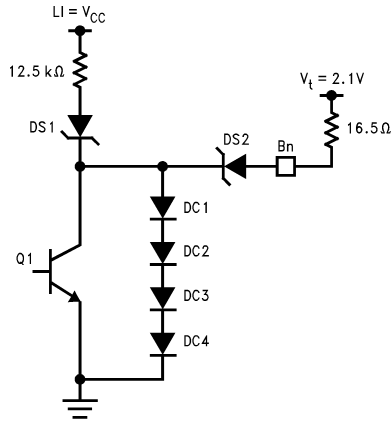

AN011482-1

AN-834

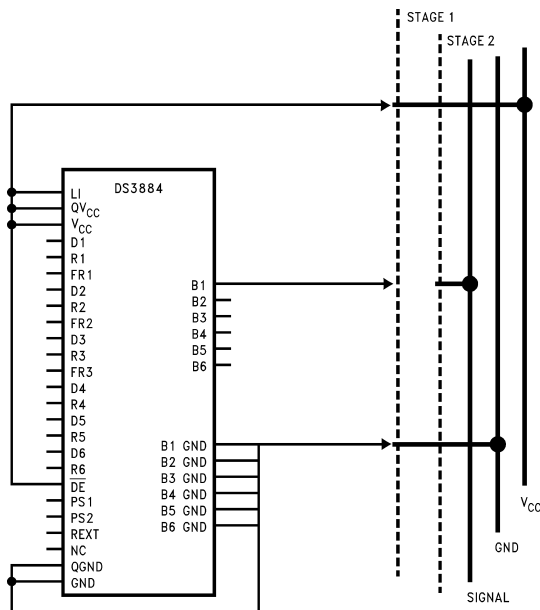

AN011482-2

Live insertion was tested using this basic set-up. Some of the testing done included a 1 M $\Omega$  pull-up or pull-down resistor to V<sub>CC</sub> or ground, respectively. Test done with device and connector excluding the board differs in that QV<sub>CC</sub>, V<sub>CC</sub> and DE were not connected to 5V.

**FIGURE 1. Live Insertion Diagram**

The waveforms shown on *Figure 2* to *Figure 7* are based on multiple board insertions. In each figure several waveforms are superimposed to show the various glitches observed. The waveforms shown were chosen from at least thirty that were taken for each case.

Case 1: All power pins connected—Prior to insertion all the power pins including LI and DE are connected together as shown on *Figure 1*. When the board was inserted into a backplane that was in a high state, the glitch had a maximum

negative amplitude of 150 mV, as shown in *Figure 2*. The glitch reached an absolute minimum level of 1.94V. The noise margin below the glitch is about 320 mV. The noise margin is equal to the absolute minimum level minus V<sub>IH min</sub> of the receiver which is 1.62V.

When the board was inserted into a backplane that was in a low state, no glitch was observed on the backplane as shown on *Figure 3*. The low state on the backplane is accomplished by having another board pull the bus low.

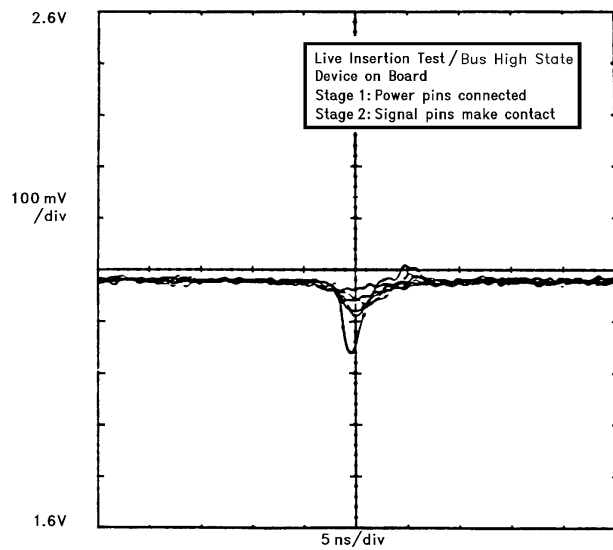

AN011482-3

FIGURE 2.

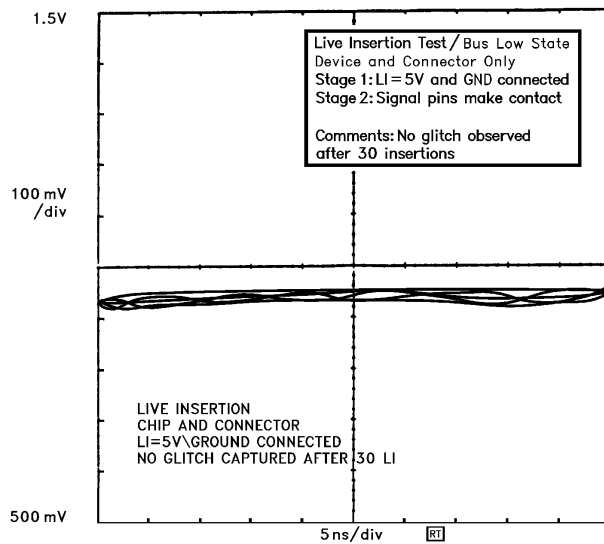

AN011482-4

FIGURE 3.

Case 2: Live insertion pin connected—Prior to insertion, LI is connected to the power pins.  $LV_{CC}$ ,  $QV_{CC}$  and  $\overline{DE}$  are left floating. The device was directly soldered on a connector

since the board was not re-configurable for this set-up. As shown on *Figure 4* and *Figure 5*, no glitch was observed when the backplane was high or low prior to insertion.

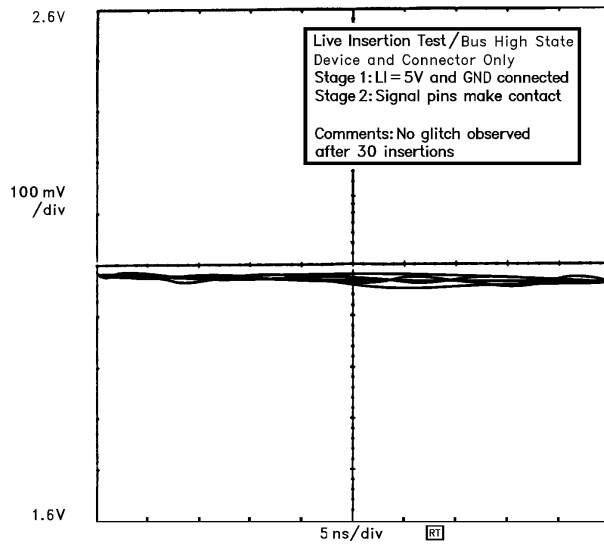

FIGURE 4.

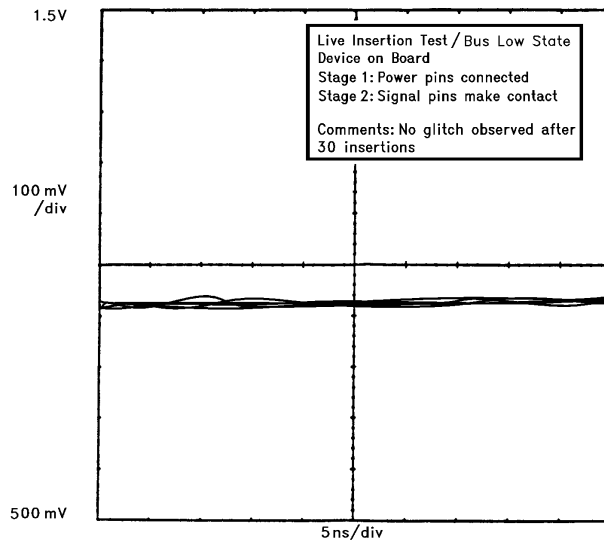

FIGURE 5.

Case 3: Live insertion pin connected to  $V_{CC}$  and B port has a  $1\text{ M}\Omega$  pull-up to  $V_{CC}$ . Case three was performed to insure that the test methodology in case two was correct. To intentionally cause a glitch during insertion, a  $1\text{ M}\Omega$  pull-up resistor was used to bias the output to  $V_{CC}$  before inserting the device into a backplane. The backplane was in a low state prior to insertion. The maximum amplitude of the glitch was 1240 mV as shown in Figure 6. The noise margin above the glitch was 230 mV where noise margin is equal to  $V_{IL}$  of the receiver ( $V_{IL\text{ max}} = 1.47\text{V}$ ) minus maximum amplitude.

Case 4: Live insertion pin connected to  $V_{CC}$  and B port has a  $1\text{ M}\Omega$  pull-down to ground. Case four was performed to insure that the test methodology in case two was correct. To intentionally cause a glitch during insertion, a  $1\text{ M}\Omega$  resistor was used to bias the output to ground before inserting the device into a backplane. The backplane was in a high state prior to insertion. The glitch reached a minimum level of 1.925V which was 325 mV away from  $V_{IH}$  of the receiver ( $V_{IH\text{ min}} = 1.62\text{V}$ ) as shown on Figure 7.

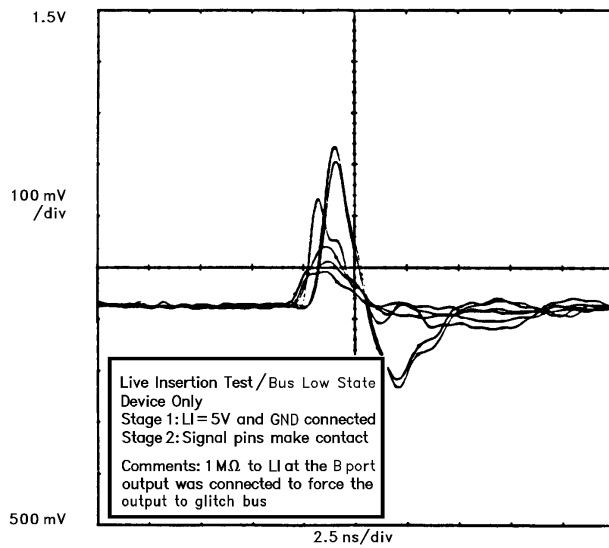

FIGURE 6.

**SUMMARY**

The live insertion pin LI for the Futurebus+ transceiver was designed so that the outputs could be reverse biased during live insertion prior to powering up the whole board. Reverse biasing the outputs will present minimum loading to the bus. Results showed that when LI was pulled up to  $V_{CC}$ , with  $QV_{CC}$  and  $LV_{CC}$  floating, prior to insertion no glitch was observed on the backplane. When all power pins ( $V_{CC}$ , LI,  $QV_{CC}$ ) and driver enable ( $\overline{DE}$ ) were connected to  $V_{CC}$  prior

to insertion, the glitch never crossed threshold. This does not prove that there is no chance of a Live insertion glitch that may cross the threshold, but it does indicate the nature of that possible glitch. The investigations show that the glitch peak amplitude will be of short duration if it should cross the receiver threshold from either direction. If that should be the case, then National's BTL/Futurebus+ transceivers have a natural glitch rejection specified at 1 ns typical, in case a live insertion signal does cross threshold.

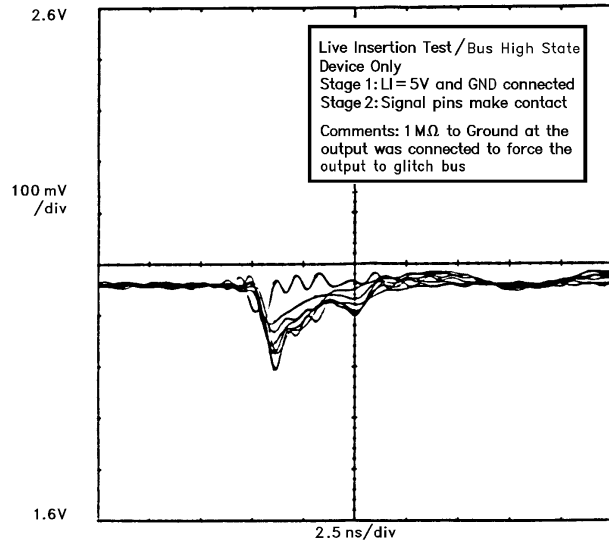
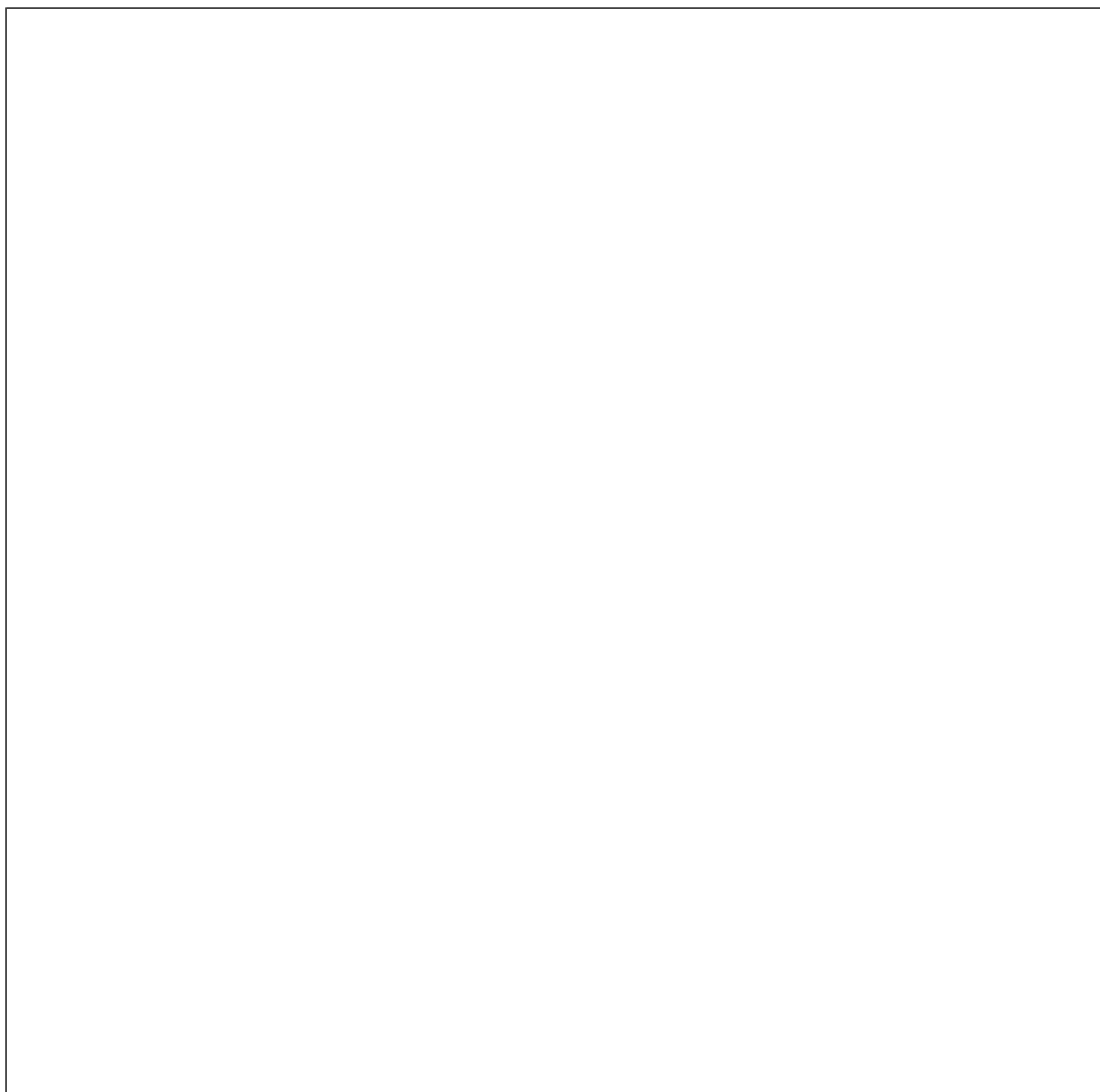

FIGURE 7.



**LIFE SUPPORT POLICY**

NATIONAL'S PRODUCTS ARE NOT AUTHORIZED FOR USE AS CRITICAL COMPONENTS IN LIFE SUPPORT DEVICES OR SYSTEMS WITHOUT THE EXPRESS WRITTEN APPROVAL OF THE PRESIDENT OF NATIONAL SEMICONDUCTOR CORPORATION. As used herein:

- 1. Life support devices or systems are devices or systems which, (a) are intended for surgical implant into the body, or (b) support or sustain life, and whose failure to perform when properly used in accordance with instructions for use provided in the labeling, can be reasonably expected to result in a significant injury to the user.
- 2. A critical component in any component of a life support device or system whose failure to perform can be reasonably expected to cause the failure of the life support device or system, or to affect its safety or effectiveness.

|  |   |  |   |
|--|---|--|---|
|  <p><b>National Semiconductor Corporation</b><br/>Americas<br/>Tel: 1-800-272-9959<br/>Fax: 1-800-737-7018<br/>Email: support@nsc.com</p> | <p><b>National Semiconductor Europe</b><br/>Fax: +49 (0) 1 80-530 85 86<br/>Email: europe.support@nsc.com<br/>Deutsch Tel: +49 (0) 1 80-530 85 85<br/>English Tel: +49 (0) 1 80-532 78 32<br/>Français Tel: +49 (0) 1 80-532 93 58<br/>Italiano Tel: +49 (0) 1 80-534 16 80</p> | <p><b>National Semiconductor Asia Pacific Customer Response Group</b><br/>Tel: 65-2544466<br/>Fax: 65-2504466<br/>Email: sea.support@nsc.com</p> | <p><b>National Semiconductor Japan Ltd.</b><br/>Tel: 81-3-5620-6175<br/>Fax: 81-3-5620-6179</p> |
|--|---|--|---|

www.national.com

National does not assume any responsibility for use of any circuitry described, no circuit patent licenses are implied and National reserves the right at any time without notice to change said circuitry and specifications.

## IMPORTANT NOTICE

Texas Instruments Incorporated and its subsidiaries (TI) reserve the right to make corrections, modifications, enhancements, improvements, and other changes to its products and services at any time and to discontinue any product or service without notice. Customers should obtain the latest relevant information before placing orders and should verify that such information is current and complete. All products are sold subject to TI's terms and conditions of sale supplied at the time of order acknowledgment.

TI warrants performance of its hardware products to the specifications applicable at the time of sale in accordance with TI's standard warranty. Testing and other quality control techniques are used to the extent TI deems necessary to support this warranty. Except where mandated by government requirements, testing of all parameters of each product is not necessarily performed.

TI assumes no liability for applications assistance or customer product design. Customers are responsible for their products and applications using TI components. To minimize the risks associated with customer products and applications, customers should provide adequate design and operating safeguards.

TI does not warrant or represent that any license, either express or implied, is granted under any TI patent right, copyright, mask work right, or other TI intellectual property right relating to any combination, machine, or process in which TI products or services are used. Information published by TI regarding third-party products or services does not constitute a license from TI to use such products or services or a warranty or endorsement thereof. Use of such information may require a license from a third party under the patents or other intellectual property of the third party, or a license from TI under the patents or other intellectual property of TI.

Reproduction of TI information in TI data books or data sheets is permissible only if reproduction is without alteration and is accompanied by all associated warranties, conditions, limitations, and notices. Reproduction of this information with alteration is an unfair and deceptive business practice. TI is not responsible or liable for such altered documentation. Information of third parties may be subject to additional restrictions.

Resale of TI products or services with statements different from or beyond the parameters stated by TI for that product or service voids all express and any implied warranties for the associated TI product or service and is an unfair and deceptive business practice. TI is not responsible or liable for any such statements.

TI products are not authorized for use in safety-critical applications (such as life support) where a failure of the TI product would reasonably be expected to cause severe personal injury or death, unless officers of the parties have executed an agreement specifically governing such use. Buyers represent that they have all necessary expertise in the safety and regulatory ramifications of their applications, and acknowledge and agree that they are solely responsible for all legal, regulatory and safety-related requirements concerning their products and any use of TI products in such safety-critical applications, notwithstanding any applications-related information or support that may be provided by TI. Further, Buyers must fully indemnify TI and its representatives against any damages arising out of the use of TI products in such safety-critical applications.

TI products are neither designed nor intended for use in military/aerospace applications or environments unless the TI products are specifically designated by TI as military-grade or "enhanced plastic." Only products designated by TI as military-grade meet military specifications. Buyers acknowledge and agree that any such use of TI products which TI has not designated as military-grade is solely at the Buyer's risk, and that they are solely responsible for compliance with all legal and regulatory requirements in connection with such use.

TI products are neither designed nor intended for use in automotive applications or environments unless the specific TI products are designated by TI as compliant with ISO/TS 16949 requirements. Buyers acknowledge and agree that, if they use any non-designated products in automotive applications, TI will not be responsible for any failure to meet such requirements.

Following are URLs where you can obtain information on other Texas Instruments products and application solutions:

### Products

|                        |  |
|------------------------|--|
| Audio                  | <a href="http://www.ti.com/audio">www.ti.com/audio</a>                               |
| Amplifiers             | <a href="http://amplifier.ti.com">amplifier.ti.com</a>                               |
| Data Converters        | <a href="http://dataconverter.ti.com">dataconverter.ti.com</a>                       |
| DLP® Products          | <a href="http://www.dlp.com">www.dlp.com</a>   |
| DSP                    | <a href="http://dsp.ti.com">dsp.ti.com</a>   |
| Clocks and Timers      | <a href="http://www.ti.com/clocks">www.ti.com/clocks</a>                             |
| Interface              | <a href="http://interface.ti.com">interface.ti.com</a>                               |
| Logic                  | <a href="http://logic.ti.com">logic.ti.com</a>                                       |
| Power Mgmt             | <a href="http://power.ti.com">power.ti.com</a>                                       |
| Microcontrollers       | <a href="http://microcontroller.ti.com">microcontroller.ti.com</a>                   |
| RFID                   | <a href="http://www.ti-rfid.com">www.ti-rfid.com</a>                                 |
| OMAP Mobile Processors | <a href="http://www.ti.com/omap">www.ti.com/omap</a>                                 |
| Wireless Connectivity  | <a href="http://www.ti.com/wirelessconnectivity">www.ti.com/wirelessconnectivity</a> |

### Applications

|                               |  |
|-------------------------------|--|
| Communications and Telecom    | <a href="http://www.ti.com/communications">www.ti.com/communications</a>                 |
| Computers and Peripherals     | <a href="http://www.ti.com/computers">www.ti.com/computers</a>                           |
| Consumer Electronics          | <a href="http://www.ti.com/consumer-apps">www.ti.com/consumer-apps</a>                   |
| Energy and Lighting           | <a href="http://www.ti.com/energy">www.ti.com/energy</a>                                 |
| Industrial                    | <a href="http://www.ti.com/industrial">www.ti.com/industrial</a>                         |
| Medical                       | <a href="http://www.ti.com/medical">www.ti.com/medical</a>                               |
| Security                      | <a href="http://www.ti.com/security">www.ti.com/security</a>                             |
| Space, Avionics and Defense   | <a href="http://www.ti.com/space-avionics-defense">www.ti.com/space-avionics-defense</a> |
| Transportation and Automotive | <a href="http://www.ti.com/automotive">www.ti.com/automotive</a>                         |
| Video and Imaging             | <a href="http://www.ti.com/video">www.ti.com/video</a>                                   |

TI E2E Community Home Page

[e2e.ti.com](http://e2e.ti.com)

Mailing Address: Texas Instruments, Post Office Box 655303, Dallas, Texas 75265  
Copyright © 2011, Texas Instruments Incorporated