

OA-26 Designing Active High Speed Filters

ABSTRACT

This application report provides a recipe to realize active filters using low cost, high speed operational amplifiers.

Contents

1	Introduction	2
2	Filter Types	2
3	Introduction to the Second Order, Low Pass Sallen-Key Filter	3
4	Transform a Low Pass Filter into a High Pass Filter	5
5	Cascading Filter Sections	6
6	Component Value Sensitivities	7
7	Selecting an Op Amp for Use in an Active Filter	7
8	Bandwidth	7
9	Recommended Gain Range	7
10	Noise	8
11	Dynamic Range	8
12	Secondary Specifications	8
13	Summary of High Speed Dual Op Amps	8
14	Compensation for Finite Bandwidth Amplifiers	8
15	The Active Filter Boards	10
16	Conclusion	10
17	Schematic	10
18	Layout	11
Appendix A	Filter Design Tables	12
Appendix B	Non-Equal C Sallen-Key Filter Methodology	13
Appendix C	Transfer Functions for Some of the Filters	14
Appendix D	Bibliography	14

List of Figures

1	Sallen-Key Low Pass Filter with Equal C_s	3
2	Example of Low Pass Filter.....	4
3	Sallen-Key High Pass Filter	5
4	3 rd Order Sallen-Key Filter	6
5	Low Pass Sallen-Key Filter	9
6	Schematic for Active Filter Board (No longer available as of 1/13/05)	10
7	Top and Bottom Views of Active Filter Evaluation Board (No longer available as of 1/13/05)	11
8	2 Pole Sallen-Key Low Pass Filter with Unequal Capacitors	13

List of Tables

1	Butterworth Low Pass Filter.....	12
2	Bessel Low Pass Filter	12
3	0.1 dB Ripple Chebyshev Filter.....	12
4	1.00 dB Ripple Chebyshev Filter	12

All trademarks are the property of their respective owners.

1 Introduction

Filters built from resistors (R), inductors (L) and capacitors (C) are known as RLC or passive filters and are the dominant type of filter for high frequency applications. The performance of these filters is typically limited by the inductors which are large, expensive and far from ideal in an electrical sense. By using amplifiers and feedback, the same filter characteristics can be achieved without the use of inductors, these filters are known as “active filters”. An active filter will perform well only to the extent that the amplifiers in it behave in an ideal sense, so traditionally active filters have been limited to applications at frequencies below 1 MHz. With the advent of low cost, very high speed operational amplifiers, it is now feasible to realize active filters with frequency ranges in the tens of MHz. With some of the newer high speed amplifiers such as the CLC449 – a 1.2 GHz bandwidth amplifier, filters with corner frequencies above 100 MHz have been built.

The filter topology that is used is the Sallen-Key Filter which uses the operational amplifier as a fixed gain block. This filter topology can be used with current feed-back or voltage feedback amplifiers, and you will be shown how to design low pass, high pass and band pass filters using this filter topology. This application note discusses a printed circuit board which will allow you to prototype active filters of up to 8 pole complexity (As of 1/13/05, board is no longer available). This is not a complete treatment of the subject of active filters, there are several good books published on that topic, some of which are listed in the bibliography. This is a simple method of getting a circuit that will work for most applications. The topics covered are:

- Filter Types
- Introduction to the second order, low pass Sallen-Key Filter
- RC:CR Transformations to realize second order, high pass Sallen-Key Filters
- Cascading filter sections to achieve higher order filters and Band Pass Filters
- Sensitivities to component values
- How to select an Op-amp for use in an active filter
- Compensation for finite Bandwidth Amplifiers
- The TI active filter evaluation boards (as of January 13, 2005, board is no longer available)

2 Filter Types

2.1 Butterworth Response

The Butterworth response maximizes the flatness in the pass band of the filter. The response is very flat near DC then begins to slowly roll off so that it is at -3 dB at the cutoff frequency, and approaches an ultimate rolloff rate of -20ndB/decade where n is the order of the filter. Butterworth filters are used it is very important to maintain gain flatness, especially at low frequencies.

2.2 Bessel Response

In addition to altering the magnitude of the input signal depending upon its frequency, filters introduce a delay into the signal which is dependent upon frequency. This introduces a frequency dependent phase shift which distorts non-sinusoidal signals. Just as the Butterworth response maximizes the amplitude flatness through the passband, a Bessel Response minimizes the phase non-linearity in the passband.

2.3 Chebyshev Response

In some applications, the most important factor is how fast the filter cuts off the unwanted signal. Faster rolloff than what is seen by the Butterworth filter can be achieved if you are willing to accept some ripple in the passband.

Appendix A contains tables with the parameters required to design filters up to order 8 with Butterworth, Bessel, and Chebyshev responses. There are two tables for the Chebyshev response: one for 0.1dB maximum ripple in the passband, and one for 1dB of ripple in the passband.

3 Introduction to the Second Order, Low Pass Sallen-Key Filter

The circuit shown in [Figure 1](#) is a two pole, Sallen-Key Low Pass Filter. This filter (and any two pole filter) can be characterized by three parameters: K, ω_0 and Q. K is the DC gain of the filter. ω_0 is a measure of the corner frequency of the filter, while Q is a measure of how closely spaced the two poles are in the S plane. The values of K, Q and ω_0 are given by:

$$K = 1 + \frac{R_F}{R_G}, \quad Q = \frac{m}{1 + m^2(2-K)}, \quad \omega_0 = \frac{1}{mRC} \quad (1)$$

Q, K are unitless

ω_0 is in units of radians/sec. Divide ω_0 by 2π to get it in Hz.

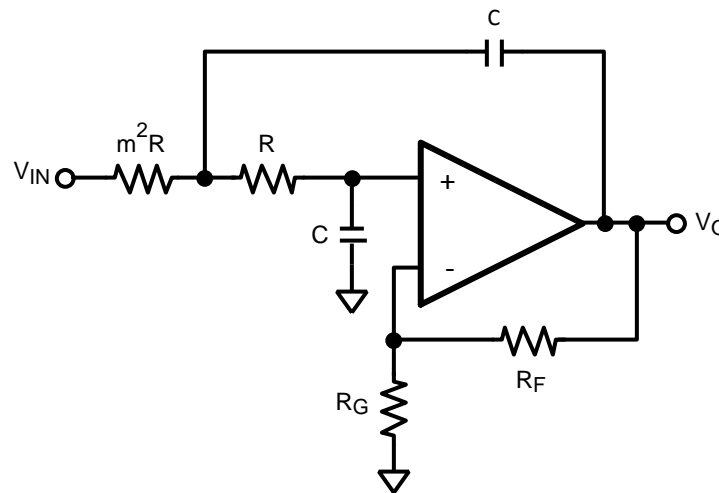

Figure 1. Sallen-Key Low Pass Filter with Equal C_s

The methodology to design a particular filter is to select the desired values for K, Q and ω_0 and then to use the above equations to determine the component values required. Q can be obtained from the filter table in appendix A. ω_0 is your cutoff frequency and will be given to you from the design specification. In most filters, the actual value of ω_0 that you design for must be adjusted by the factor found in the filter table to get the proper -3 dB frequency. K is another parameter that will be provided as part of the filter specification.

Since these three parameters are not completely independent, it may not be possible to meet all three points simultaneously. In this case, you should select another value of K, and then use an amplifier before or after the filter to make the overall gain meet the system requirements.

The methodology to use in selecting component values is outlined:

1. Select R_F and R_G to obtain the desired K. If the amplifier that you are using is a current feedback amplifier, follow the guidelines in the datasheet to select appropriate values of R_F and R_G
2. Determine the value of m required using the following equation and the value of Q found in the design table:

$$m = \frac{1 \pm \sqrt{1 - 4Q^2(2-K)}}{2Q(2-K)}$$

3. If you cannot get a positive real solution for m, then select another value of K and go back to step 1.
4. Arbitrarily select a value for C.
5. Determine the value of ω_0 to use by multiplying your desired cutoff frequency by the value of " ω_p " found in the Appendix A table (ω_p is ω_1 for a single 2^{nd} order stage-additional cascaded stages would be ω_2 , ω_3 , etc.) found in the filter design table. If your frequency specification is in Hz, remember to multiply it by 2π to get it into radians/sec.

6. Determine the value of R required using the equation:

$$R = \frac{1}{\omega_0 m C}$$

7. If R turns out to be too large or too small for practical purposes, select another value for C (if R is too big, select a larger value for C, if R is too small select a smaller value of C) then go back to step 6.

Example:

Design a Butterworth filter, with a cutoff frequency of 10 MHz, and a DC gain of 1.5. The CLC430 will be used in this example.

1. Select $R_F = 700\Omega$, $R_G = 1.4\text{ k}\Omega$ as per the CLC430 data sheet.
2. Find Q from table: 0.707, use this to determine $m = 1.41$
3. Arbitrarily select $C = 0.1\ \mu\text{F}$
4. $\omega_0 = 62.8\text{E}6$ for a 10 MHz filter
5. Calculate R. R turns out to be 0.111Ω
6. R is too small, therefore try a smaller C, and return to step 6. Select $C = 100\ \text{pF}$.
7. $R = 112.5\Omega$, much better.

Figure 2 illustrates the final filter topology.

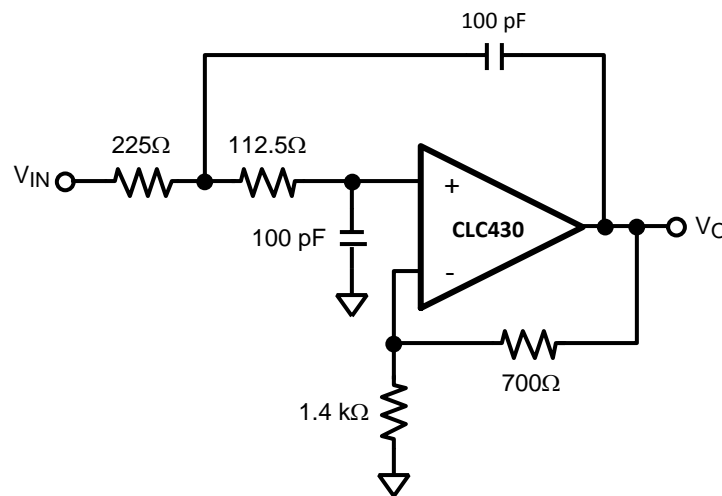

Figure 2. Example of Low Pass Filter

With slight modifications, the CLC430's evaluation board, CLC730013, can be used to test this circuit.

In some cases, it may be difficult to realize the desired filter with the constraint of equal valued capacitors. If this is the case, see appendix B to obtain expressions for Q and ω_0 where the capacitors can take on different values. This is most often necessary when trying to realize a filter with a high Q.

4 Transform a Low Pass Filter into a High Pass Filter

By changing capacitors into resistors, and resistors into capacitors, a low pass filter can be changed into a high pass filter. To make a high pass filter from a lowpass filter, replace each capacitor of value C with a resistor of value $1/\omega_0 C$, and each resistor with a capacitor of value $1/\omega_0 R$. For example the 100 pF capacitors in the example circuit from the previous section should be replaced with 159Ω resistors, the 225Ω resistor should be replaced with a 71 pF capacitor, and the 112Ω resistor should be replaced with a 142 pF cap.

Alternately you can calculate component values using a method similar to that shown in the previous section. Figure 3 is a second order Sallen-Key High pass filter. Q and ω_0 are given by

$$Q = \frac{n}{1 + n^2 (2-K)} \quad \text{and} \quad \omega_0 = \frac{1}{nRC}$$

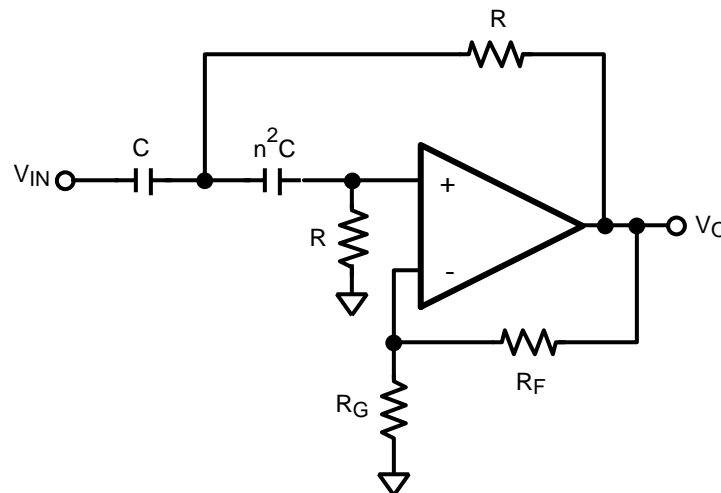

Figure 3. Sallen-Key High Pass Filter

5 Cascading Filter Sections

Higher order filters can be realized by cascading lower order filters. A filter of order n can be realized by cascading $n/2$ second order sections. Note that to obtain a fourth order Butterworth filter you do not cascade two second order Butterworth filter sections. The pole locations for the fourth order filter are all different and different values of Q and ω_0 will need to be used for each section. For example, to get a 4th order Bessel Low Pass filter with a 10 MHz cut-off frequency, here are the ω_0 and Q of the two 2nd order stages:

	f_0 (MHz)	Q
Stage 1	14.2	0.522
Stage 2	15.9	0.806

Cascading active filters of the Sallen-Key topology is easy. Since the output impedances of the filters are very small, cascading them consists of just connecting one section to the next (each filter section is designed assuming 0 source impedance.)

If a filter of odd order is desired, the last pole can be added with a simple passive filter at the output of the active filter as shown in [Figure 4](#).

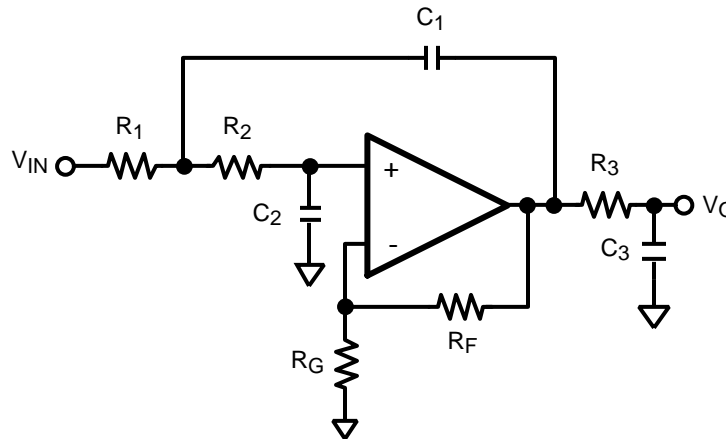

Figure 4. 3rd Order Sallen-Key Filter

When cascading filters, one question that arises is what order the sections should be placed. The answer to this is the same as the answer to all filter questions – “it depends”. Two factors that need to be considered when cascading filter sections are “Am I liable to have intermediate signals that might clip or distort?” and “How important is noise to me?”

In filters with sections where there are large Q s, the maximum amplitude of the signal in between stages may be larger than the input or the output amplitude. This can lead to undue distortion of the signal. This will most likely be an issue if there are filter sections with large Q s, and the input signals are large. Strategies that can be used to combat this effect are to put the stages with the lowest Q s and gains first, and cascade the higher gain sections later. Another way that the dynamic range could be increased would be to use an op-amp with larger dynamic range. The CLC432 is a dual, current feedback op-amp that is well suited to active filter applications and has an output voltage swing of 28 V_{pp} when driving a light load.

In order to minimize the broadband noise that is present in an active filter, stages should be cascaded with the highest Q , and highest gain sections first, then followed by lower gain sections. Other strategies that should be considered when trying for low noise are using the lowest possible value resistors to reduce thermal noise and to select low noise op amps such as the CLC428, dual, voltage feedback op amp.

As you can see from the previous two paragraphs, the order in which to place the filter stages is dependent upon the requirements of your application. There is no best way to cascade your filter stages.

6 Component Value Sensitivities

If the component values used in realizing the filter are not exactly what the calculations arrive at, and they won't be, then the filter characteristics will be different from what was desired. Even if time is spent trimming components to the exact desired value, variations caused by temperature shifts, aging and other external and internal sources will cause the filter characteristics to vary. A good design will result in minimal variation in the filter characteristics as a result of the component value variations that might be expected. To estimate the effect on the filter characteristics as component values vary, sensitivity figures are used.

A sensitivity figure tells how much variation there will be in one characteristic when a parameter is changed. Hence S_R^ω refers to the incremental change in ω for an incremental change in R. If S_R^ω is 2 then there will be a 2% variation in ω for a 1% variation in R. The two parameters with which we are most concerned in our filter designs are Q and ω_0 , therefore it would be useful to look at what component variations have an effect on these parameters, and to determine what these sensitivities are.

S_x^A is defined as:

$$S_x^A = \frac{d(\ln A)}{d(\ln x)} = \frac{x}{A} \frac{dA}{dx}$$

In the lowpass filter of [Figure 1](#), the equation that describes Q, has m and K as its variables, hence Q is only sensitive to the ratio of resistor values and to K which is determined by R_F and R_G . For this filter the sensitivity that we have to worry the most about is the sensitivity to K, which is very large for high Q sections.

7 Selecting an Op Amp for Use in an Active Filter

Although there are many factors that go into selecting an op amp for use in any application, most filter applications can be satisfied by looking at a just four parameters: Bandwidth Recommended Gain range Noise Dynamic Range

- Bandwidth
- Recommended Gain Range
- Noise
- Dynamic Range

8 Bandwidth

As a general rule, when selecting an op amp for a filter, make certain that it has a bandwidth of at least 10x the intended filter frequency, and preferably 20x. As an example to design a 10 MHz low pass filter, use an op amp with at least 100 MHz of bandwidth. If designing a high pass filter, make certain that the bandwidth of the op amps will be sufficient to pass all of your signal. Another point to watch is that your op amp must have this band-width under the conditions that you intend to use it, for example, the same gain, signal level and power supply voltage. An op amp that is specified as a 100 MHz op amp because it has 100 MHz bandwidth with $\pm 15V$ supplies, 50 mV output level and a gain of 1 is not likely to be useful in a 10 MHz filter application. If in doubt, configure the amplifier that you are considering at the gain that you are intending to use (K) and measure its bandwidth.

9 Recommended Gain Range

Your filter design will be dictating to you the gains at which you will be setting your op amps. If the chosen op amp is a voltage feedback op amp, use at gains outside the recommended gain range is liable to lead to lower than expected bandwidth at best and oscillation at worst. For a current feedback op amp, operation at gains outside of the recommended range is liable to force you to use resistor values for R_F and R_G which are way too small or large for practical realization.

10 Noise

The input voltage and current noises of the op amp will contribute to the noise at the output of the filter. In applications where noise is a major concern, you will need to calculate these contributions (as well as the contributions of the thermal noise of the resistors in the circuit) to determine if the added noise encountered with an active filter is acceptable. Noise can be reduced by selecting low noise, high speed op amps such as the CLC425 or CLC428.

11 Dynamic Range

In filters which have high Q sections, it is possible that there will be intermediate signals that are larger than either the input signal or the output signal. For the filter to operate properly, all of these signals must be passed without clipping or excessive distortion.

12 Secondary Specifications

In addition to the four primary specifications above, there are several secondary parameters that you may want to take into consideration. These would include phase linearity (this is generally better in current feedback op amps), packaging (duals, quads available?), power dissipation, price and availability of technical support.

13 Summary of High Speed Dual Op Amps

	Bandwidth (with 500 mV output, $A_V = 2$) (MHz)	Recommended Gain Range in Filter Applications	Noise Voltage (nV/\sqrt{Hz})	Noise Current (pA/\sqrt{Hz}) (Inverting/Non- Inverting Input)	Output Dynamic Range (100 Ω Load (V))
CLC412	250	1-8	3	12/2	+3.1/-2.9
CLC416	80	1-5	2	2	+3.5/-3.5
CLC428	80	1-5	2	2	+3.5/-3.5
LM6172	50	1-5	12	1	+9/-8.5
LM6182	100	1-5	4	16/3	± 11
CLC5602	120	1-5	3	8.5/6.9	± 3.8
CLC5622	150	1-5	2.8	10/7.5	± 3.8
CLC432	62 ($V_O = 4V$)	1-20	3.3	13/2	+6/-6

14 Compensation for Finite Bandwidth Amplifiers

In all of the analysis that we have done, we have assumed that the op amps are ideal op amps with infinite bandwidth. Unfortunately, price and delivery of these op amps makes them a poor choice for actual realizable filters. The effect of using a real op amp in place of an ideal one is to slightly lower the corner frequency of the filter, and if we are somewhat clever, we can compensate for this by pre-distorting the component values of the components so that the final filter is much closer to what we wanted. The mathematical background for this is explained in the *OA-21 Component Pre-distortion for Sallen Key Filters Application Report* ([SNOA369](#)). Since the goal of this application note is to make the design of active filters easy, we are going to skip all of the development work, and go directly to the final result. To make use of this method there is a parameter that you will need to know for the op amp that you intend to use, and this is the time delay through the amplifier, called T. The value of T can be obtained in a few different ways: one is to look at the frequency response plots for the op amp that you are considering using. Find the frequency at which the phase delay is 180°, multiply this frequency by 2 and take the reciprocal to obtain the time delay through the amplifier. In the case of the CLC412, the 180° frequency is about 300 MHz, multiplying by two and taking the reciprocal yields a time delay, T, of 1.7 ns. Another way that you can get a value for T with a Texas Instruments op amp is to use the spice model, and provide the amplifier, configured as you want it, with a pulse, and measure the delay between the input edge and the output edge.

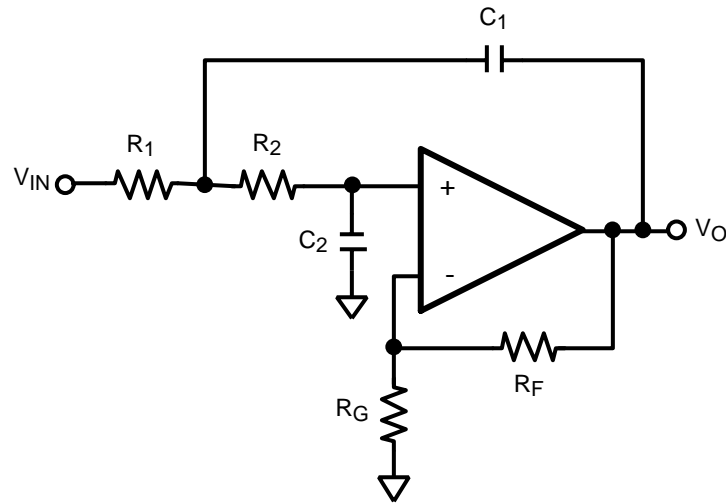

Figure 5. Low Pass Sallen-Key Filter

For the filter shown in Figure 5, you can calculate the values of R_1 and R_2 in the following way: Calculate R_2 by solving:

$$R_2^2 - bR_2 - d = 0$$

where:

$$b = \frac{1}{\omega_0 C_2} \left[\frac{1}{Q} - \omega_0 K T \right] \quad \& \quad d = \left(\frac{1}{\omega_0 C_2} \right)^2 \left(\frac{K T \omega_0}{Q} + K - 1 - \frac{1}{\alpha} \right)$$

$$\alpha = \frac{C_1}{C_2}$$

T = Time Delay through

op amp $\cong \frac{1}{2 f_u}$; f_u is the unity gain crossover
frequency of the op amp.

K = Filter DC gain

Once you have R_2 , you can get R_1 with:

$$R_1 = \frac{R_2 - \frac{1}{\omega_0 C_2 Q}}{\alpha(K - 1) - 1}$$

(2)

15 The Active Filter Boards

To make prototyping active filters easier, Comlinear has designed two different active filter evaluation boards. A schematic of the first board is shown in Figure 6. It consists of a CLC109 (or CLC111) input buffer, followed by four cascaded Sallen Key filter sections, realized with two dual op amps. The board was designed using surface mount components, so the resistors and capacitors are interchangeable. This board is available from Texas Instruments as the CLC730061 board and is shipped as a bare PCB. The top and bottom views of the evaluation board are shown in Figure 7. The other board also allows for up to four cascaded biquad sections but restricts the user to designs using $K = 1$ since rather than op amps, this board uses a quad, unity gain buffer. The board can be ordered as part number CLC730023 and is fully documented in the *CLC114EB/CLC115EB Evaluation Boards* (SNOU039) or in the 1997 Comlinear Databook.

16 Conclusion

Using the principles outlined in this application note, an active filter design need not be a daunting task. You can feel free to impress your friends at a cocktail party by whipping out pencil and paper and doing a design for a 5 MHz low pass filter. You don't have to tell them how easy it really is, just wow them and bask in their awed looks.

17 Schematic

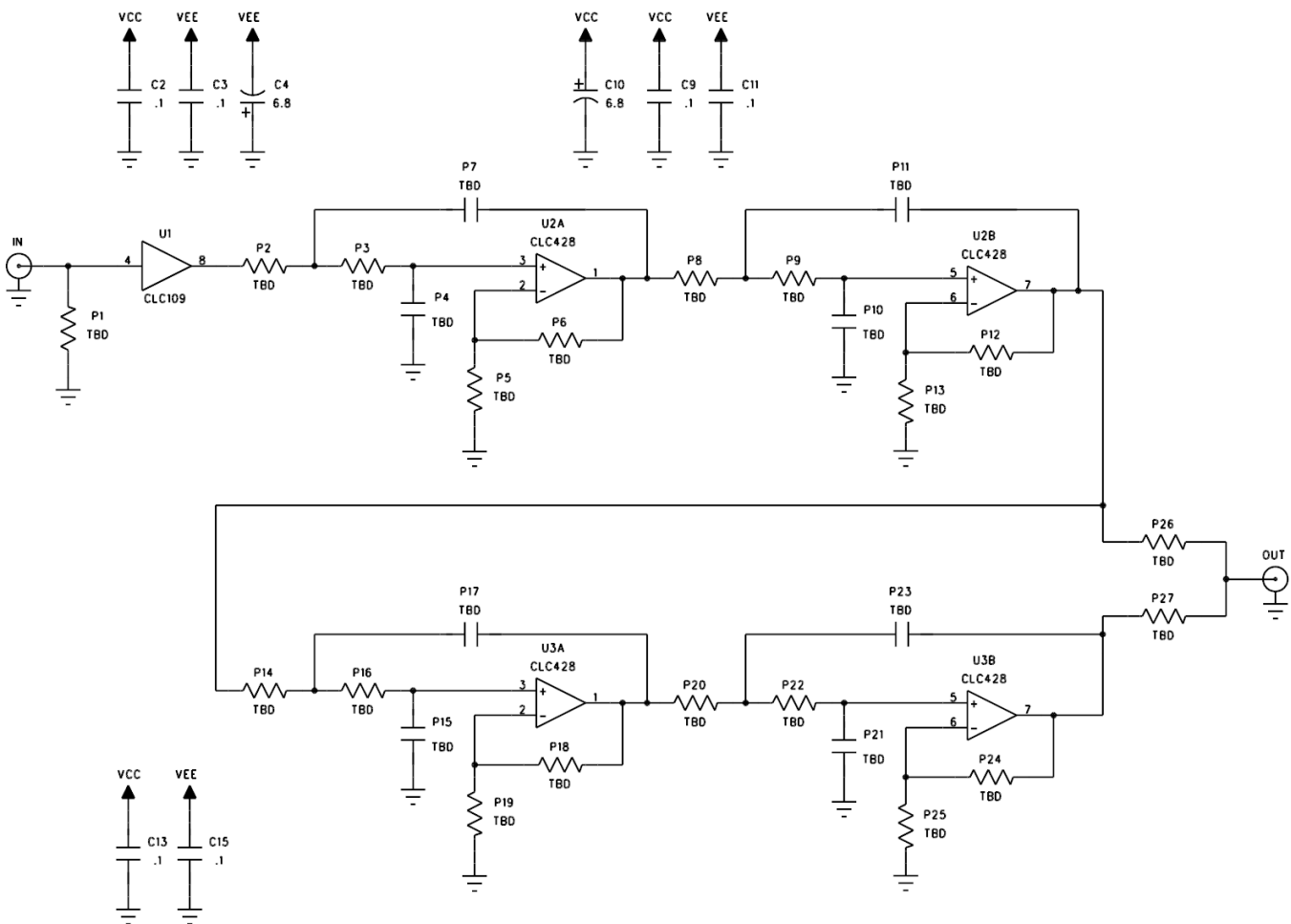

Figure 6. Schematic for Active Filter Board (No longer available as of 1/13/05)

18 Layout

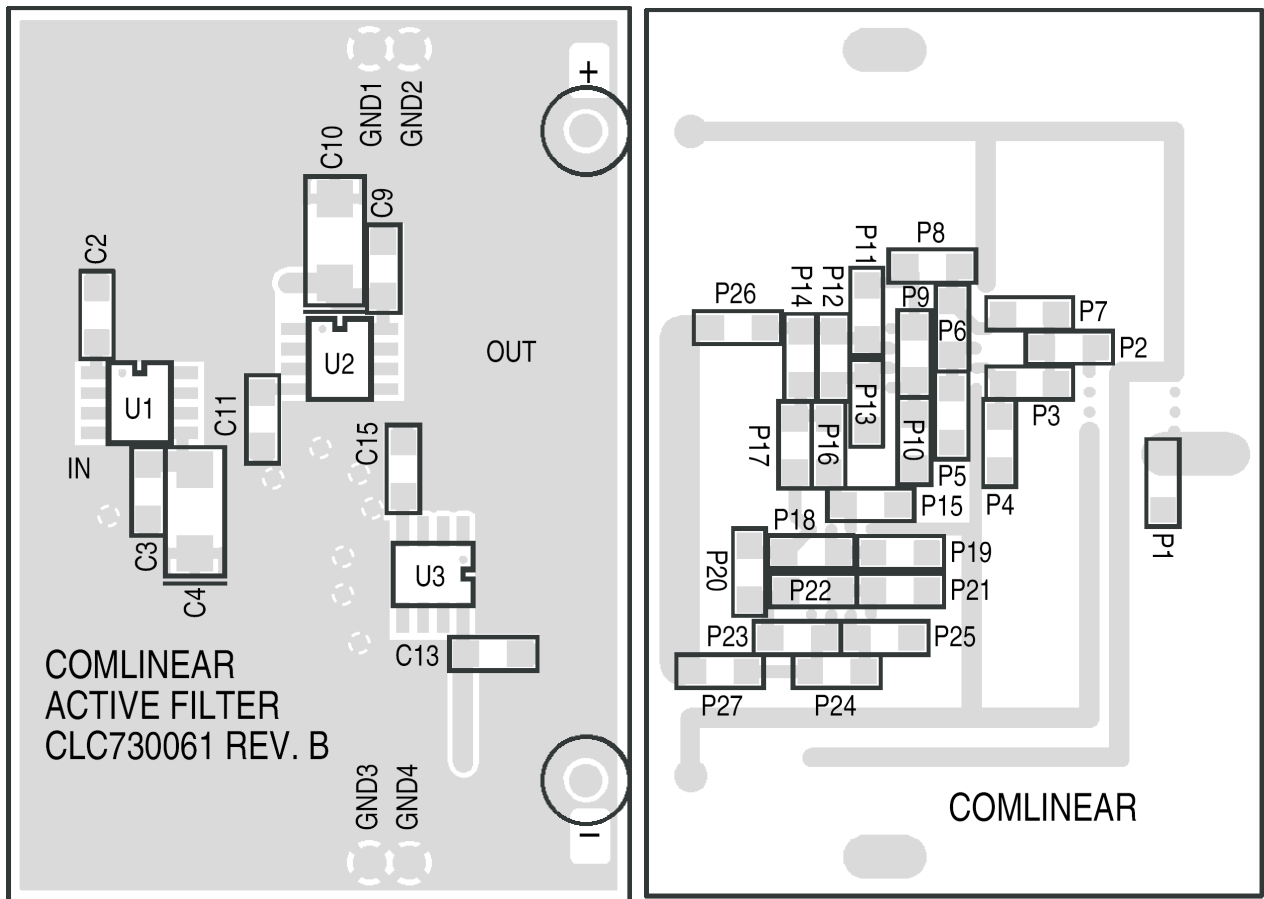

Figure 7. Top and Bottom Views of Active Filter Evaluation Board (No longer available as of 1/13/05)

Appendix A Filter Design Tables

Table 1. Butterworth Low Pass Filter

n	ω_1	Q_1	ω_2	Q_2	ω_3	Q_3	ω_4	Q_4	Attenuation at $2f_c$ (dB)
2	1	0.707							15
3	1	1.000	1						21
4	1	0.541	1	1.306					27
5	1	0.618	1	1.620	1				33
6	1	0.518	1	0.707	1	1.932			39
7	1	0.555	1	0.802	1	2.247	1		45
8	1	0.510	1	0.601	1	0.900	1	2.563	51

Table 2. Bessel Low Pass Filter

n	ω_1	Q_1	ω_2	Q_2	ω_3	Q_3	ω_4	Q_4
2	1.274	0.577						
3	1.453	0.691	1.327					
4	1.419	0.522	1.591	0.806				
5	1.561	0.564	1.760	0.917	1.507			
6	1.606	0.510	1.691	0.611	1.907	1.023		
7	1.719	0.533	1.824	0.661	2.051	1.127	1.685	
8	1.784	0.506	1.838	0.560	1.958	0.711	2.196	1.226

Table 3. 0.1 dB Ripple Chebyshev Filter

n	ω_1	Q_1	ω_2	Q_2	ω_3	Q_3	ω_4	Q_4	Attenuation at $2f_c$ (dB)
2	1.82	0.767							3.31
3	1.300	1.341	0.969						12.24
4	1.153	2.183	0.789	0.619					23.43
5	1.093	3.282	0.797	0.915	0.539				34.85
6	1.063	4.633	0.834	1.332	0.513	0.599			46.29
7	1.045	6.233	0.868	1.847	0.575	0.846	0.377		57.72
8	1.034	8.082	0.894	2.453	0.645	1.183	0.382	0.593	69.16

Table 4. 1.00 dB Ripple Chebyshev Filter

n	ω_1	Q_1	ω_2	Q_2	ω_3	Q_3	ω_4	Q_4	Attenuation at $2f_c$ (dB)
2	1.050	0.957							11.36
3	0.997	2.018	0.494						22.46
4	0.993	3.559	0.529	0.785					33.87
5	0.994	5.556	0.655	1.399	0.289				45.31
6	0.995	8.004	0.747	2.198	0.353	0.761			56.74
7	0.996	10.899	0.808	3.156	0.480	1.297	0.205		68.18
8	0.997	14.240	0.851	4.266	0.584	1.956	0.265	0.753	79.62

Appendix B Non-Equal C Sallen-Key Filter Methodology

The circuit shown in Figure 8 is a two pole, Sallen-Key low pass filter similar to the one seen in the body of this application note. The difference is that in this figure we have removed the constraint that the two capacitors remain equal by adding the “n” as an additional degree of freedom. Like the filter from Figure 1, this filter can be characterized three parameters: K, ω_0 and Q. K is the DC gain of the filter. ω_0 is a measure of the corner frequency of the filter, while Q is a measure of how closely spaced the two poles are in the S plane. The values of K, Q and ω_0 are given by:

$$K = 1 + \frac{R_F}{R_G}$$

$$Q = \frac{mn}{1 + m^2 + (mn)^2(1-K)}$$

$$\omega_0 = \frac{1}{mnRC}$$
(3)

Q, K are unitless

ω_0 is in units of radians/sec. Divide ω_0 by 2π to get it in Hz.

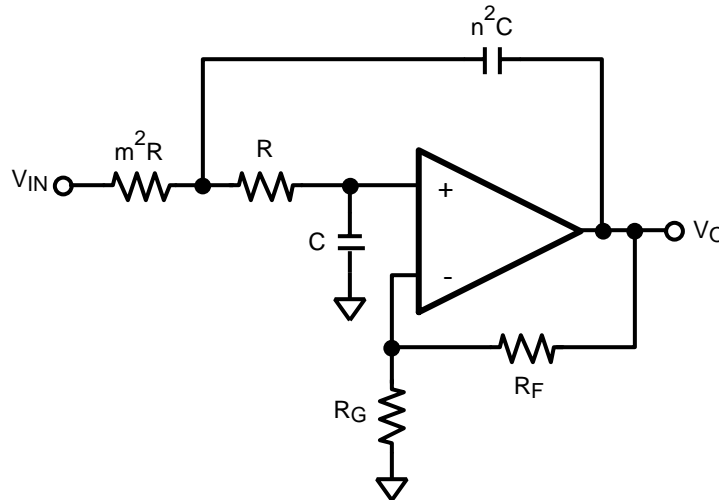

Figure 8. 2 Pole Sallen-Key Low Pass Filter with Unequal Capacitors

The methodology to design a particular filter is to select the desired values for K, Q and ω_0 and then to use the above equations to determine the component values required. Q can be obtained from the filter table in appendix A. ω_0 is your cutoff frequency and will be given to you from the design specification. In most filters, the actual value of ω_0 that you design for must be adjusted by the factor found in the filter table to get the proper -3 dB frequency (see appendix A). K is another parameter that will be provided as part of the filter specification.

The methodology to use in selecting component values is:

1. Select R_F and R_G to obtain the desired K . If the amplifier that you are using is a current feedback amplifier, follow the guidelines in the data sheet to select appropriate values of R_F and R_G .
2. Arbitrarily select a value for n . This value should be small for low Q filters and should be larger for higher Q filters. Remember that the standard values for capacitors are limited, and n should be chosen with this in mind.
3. Determine the value of m required using the following equation and the value of Q found in the design table:

$$m = \frac{\frac{n}{Q} \pm \sqrt{\left(\frac{n}{Q}\right)^2 - 4(1+n^2(1-K))}}{2(1+n^2(1-K))}$$

4. If you cannot get a positive real solution for m , then select another value of K or n and go back to step 1.
5. Arbitrarily select a value for C .
6. Determine the value of ω_0 to use by multiplying your desired cutoff frequency by the value of ω found in the filter design table. If your frequency specification is in Hz, remember to multiply it by 2π to get it into radians/sec.
7. Determine the value of R required using the equation below: $R = \frac{1}{\omega_0 m n C}$
8. If R turns out to be too large or too small for practical purposes, select another value for C (if R is too big, select a larger value for C , if R is too small select a smaller value of C) then go back to step 7.

Appendix C Transfer Functions for Some of the Filters

Transfer function for filter in [Figure 5](#):

$$\frac{V_o}{V_{in}} = \frac{\frac{K}{R_1 R_2 C_1 C_2}}{s^2 + s \left(\frac{1}{C_2 R_2} - \frac{K}{C_2 R_2} + \frac{1}{R_2 C_1} + \frac{1}{R_1 C_1} \right) + \frac{1}{R_1 R_2 C_1 C_2}}$$

Appendix D Bibliography

S. Franco: *Design with Operational Amplifiers and Analog Integrated Circuits*, McGraw Hill, 1988

K. Lacanette, ed.: *Switched Capacitor Filter Handbook*, National Semiconductor, April 1985

G. Temes and S. Mitra: *Modern Filter Theory and Design*, Wiley, 1973

M. Steffes: *Simplified Component Value Pre-Distortion For High Speed Active Filters OA-21*, Comlinear, March 1993

A.B. Williams, F.J. Taylor: *Electronic Filter Design Handbook*, McGraw Hill 1988

Note: The circuits included in this application note have been tested with Texas Instruments parts that may have been obsoleted and/or replaced with newer products. Please refer to the CLC to LMH conversion table to find the appropriate replacement part for the obsolete device..

IMPORTANT NOTICE

Texas Instruments Incorporated and its subsidiaries (TI) reserve the right to make corrections, enhancements, improvements and other changes to its semiconductor products and services per JESD46, latest issue, and to discontinue any product or service per JESD48, latest issue. Buyers should obtain the latest relevant information before placing orders and should verify that such information is current and complete. All semiconductor products (also referred to herein as "components") are sold subject to TI's terms and conditions of sale supplied at the time of order acknowledgment.

TI warrants performance of its components to the specifications applicable at the time of sale, in accordance with the warranty in TI's terms and conditions of sale of semiconductor products. Testing and other quality control techniques are used to the extent TI deems necessary to support this warranty. Except where mandated by applicable law, testing of all parameters of each component is not necessarily performed.

TI assumes no liability for applications assistance or the design of Buyers' products. Buyers are responsible for their products and applications using TI components. To minimize the risks associated with Buyers' products and applications, Buyers should provide adequate design and operating safeguards.

TI does not warrant or represent that any license, either express or implied, is granted under any patent right, copyright, mask work right, or other intellectual property right relating to any combination, machine, or process in which TI components or services are used. Information published by TI regarding third-party products or services does not constitute a license to use such products or services or a warranty or endorsement thereof. Use of such information may require a license from a third party under the patents or other intellectual property of the third party, or a license from TI under the patents or other intellectual property of TI.

Reproduction of significant portions of TI information in TI data books or data sheets is permissible only if reproduction is without alteration and is accompanied by all associated warranties, conditions, limitations, and notices. TI is not responsible or liable for such altered documentation. Information of third parties may be subject to additional restrictions.

Resale of TI components or services with statements different from or beyond the parameters stated by TI for that component or service voids all express and any implied warranties for the associated TI component or service and is an unfair and deceptive business practice. TI is not responsible or liable for any such statements.

Buyer acknowledges and agrees that it is solely responsible for compliance with all legal, regulatory and safety-related requirements concerning its products, and any use of TI components in its applications, notwithstanding any applications-related information or support that may be provided by TI. Buyer represents and agrees that it has all the necessary expertise to create and implement safeguards which anticipate dangerous consequences of failures, monitor failures and their consequences, lessen the likelihood of failures that might cause harm and take appropriate remedial actions. Buyer will fully indemnify TI and its representatives against any damages arising out of the use of any TI components in safety-critical applications.

In some cases, TI components may be promoted specifically to facilitate safety-related applications. With such components, TI's goal is to help enable customers to design and create their own end-product solutions that meet applicable functional safety standards and requirements. Nonetheless, such components are subject to these terms.

No TI components are authorized for use in FDA Class III (or similar life-critical medical equipment) unless authorized officers of the parties have executed a special agreement specifically governing such use.

Only those TI components which TI has specifically designated as military grade or "enhanced plastic" are designed and intended for use in military/aerospace applications or environments. Buyer acknowledges and agrees that any military or aerospace use of TI components which have **not** been so designated is solely at the Buyer's risk, and that Buyer is solely responsible for compliance with all legal and regulatory requirements in connection with such use.

TI has specifically designated certain components as meeting ISO/TS16949 requirements, mainly for automotive use. In any case of use of non-designated products, TI will not be responsible for any failure to meet ISO/TS16949.

Products

Audio	www.ti.com/audio
Amplifiers	amplifier.ti.com
Data Converters	dataconverter.ti.com
DLP® Products	www.dlp.com
DSP	dsp.ti.com
Clocks and Timers	www.ti.com/clocks
Interface	interface.ti.com
Logic	logic.ti.com
Power Mgmt	power.ti.com
Microcontrollers	microcontroller.ti.com
RFID	www.ti-rfid.com
OMAP Applications Processors	www.ti.com/omap
Wireless Connectivity	www.ti.com/wirelessconnectivity

Applications

Automotive and Transportation	www.ti.com/automotive
Communications and Telecom	www.ti.com/communications
Computers and Peripherals	www.ti.com/computers
Consumer Electronics	www.ti.com/consumer-apps
Energy and Lighting	www.ti.com/energy
Industrial	www.ti.com/industrial
Medical	www.ti.com/medical
Security	www.ti.com/security
Space, Avionics and Defense	www.ti.com/space-avionics-defense
Video and Imaging	www.ti.com/video

TI E2E Community

e2e.ti.com