

Measuring R_p of an L-C Sensor for Inductive Sensing

DonLiu

ABSTRACT

Three methods are introduced for the measurement of the R_p value of an L-C tank circuit using common lab equipment.

Contents

1	Introduction	1
2	R_p Measurement Method 1 – Using a Network Analyzer	1
3	R_p Measurement Method 2 – Using an Impedance Analyzer	2
4	Measurement Method 3 – Using a Signal Generator and an Oscilloscope	2
5	Conclusion	3

1 Introduction

When designing an application using TI’s LDC series of inductive sensors, it is necessary to know the L-C sensor’s equivalent parallel resistance R_p at the sensor’s resonant frequency. The R_p value changes as the target is moved; the minimum R_p occurs when the metal target is closest to the sensor. The maximum R_p occurs when the target is at the farthest distance. Accordingly, both values should be measured to ensure that the R_p value is within the proper range as defined in the datasheets.

2 R_p Measurement Method 1 – Using a Network Analyzer

A vector network analyzer can measure the complex impedance of the inductor over a range of frequency. The X_L (reactance) and R_S (series loss resistance) values are displayed at a selected frequency. Then use the formula shown in the figure to calculate the R_p at desired frequency.

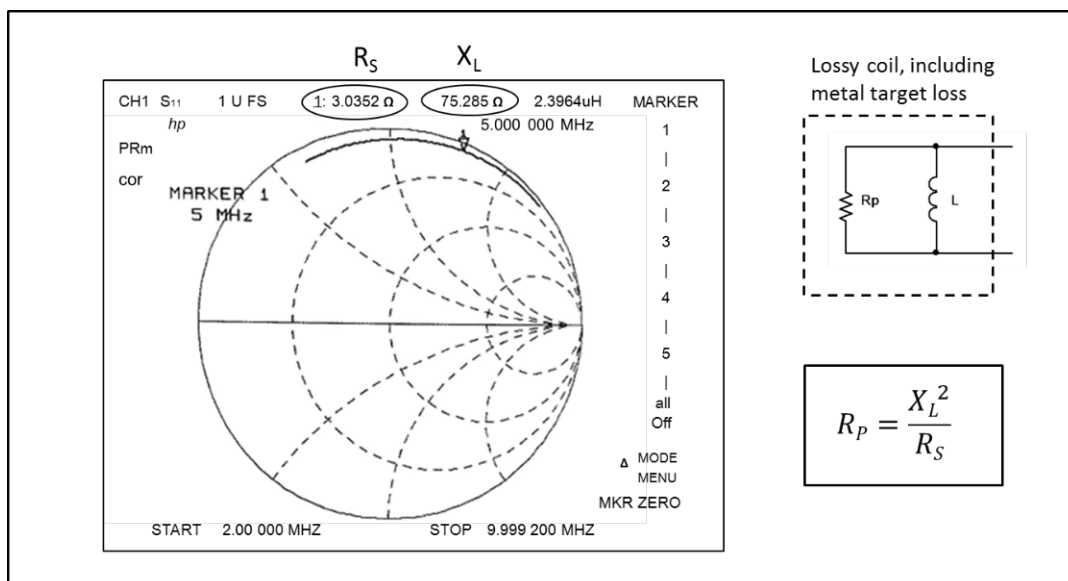

Figure 1. Using a Network Analyzer to Find R_p .

3 R_p Measurement Method 2 – Using an Impedance Analyzer

An impedance analyzer can measure the impedance of the inductor over a range of frequency. Some impedance analyzer has built-in R_p measurement function. If not, the R_p value can be calculated using the L_S (Inductance) and R_S (series loss resistance). Use the formula shown in the figure to calculate the R_p at desired frequency.

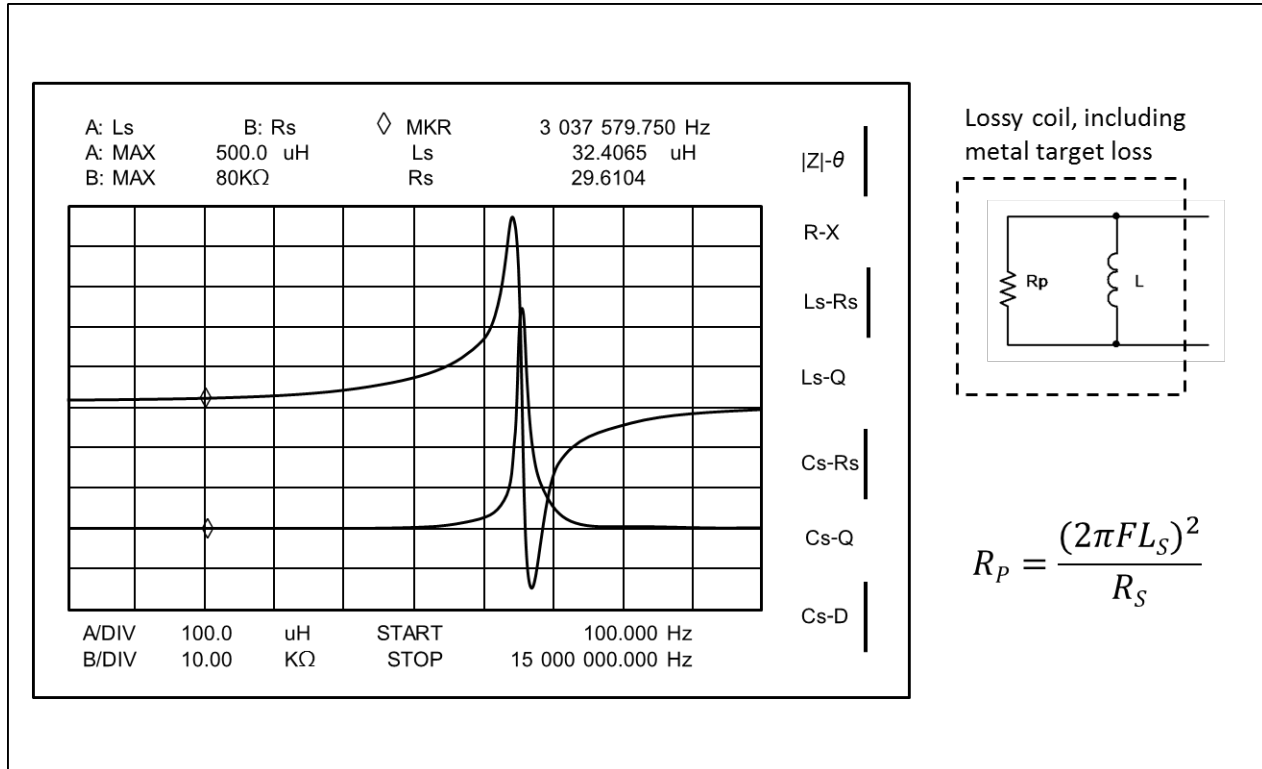

Figure 2. Using an Impedance Analyzer to Find R_p.

4 Measurement Method 3 – Using a Signal Generator and an Oscilloscope

Use a sine-wave signal generator and oscilloscope, as illustrated in Figure 3, below. Note that the LC sensor capacitor is required for this method, therefore the R_p value is measured at the resonant frequency only. Adjust the frequency so that the VPP1 reaches maximum value (resonance occurs). Adjust the R such that VPP2=2VPP1. Repeat the above steps if needed to get better accuracy. Then use an ohm meter to measure R. The value of R is the R_p of the LC sensor.

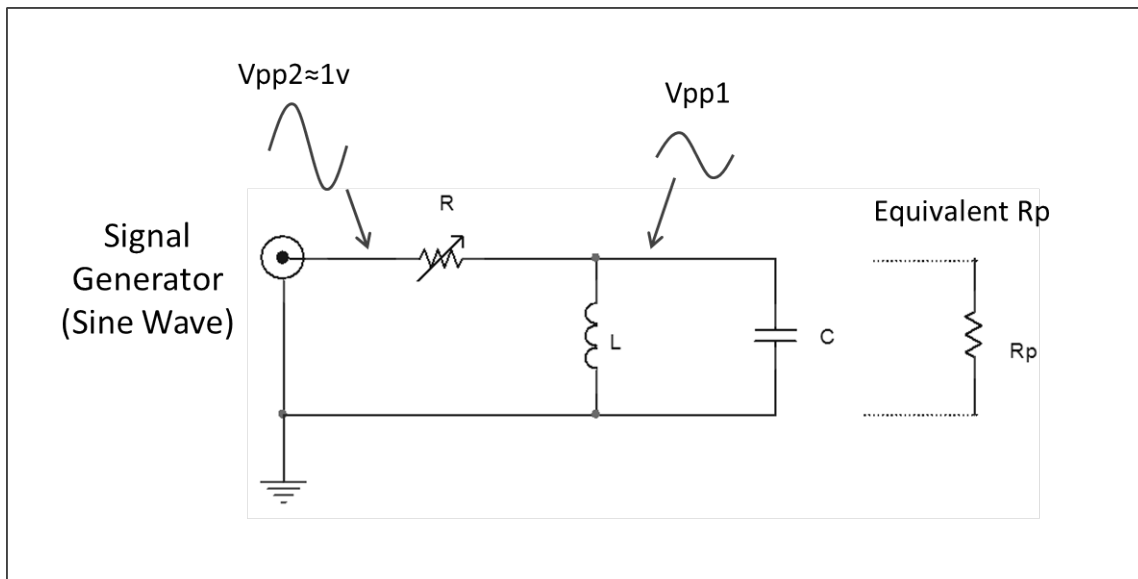

Figure 3. Using a Signal Generator and Oscilloscope to Find R_p .

5 Conclusion

To properly configure an LDC for optimum system operation, it is necessary to know the R_p range for the system. The methods described in this application note can be used to measure the expected R_p range, and combined with the guidance found in application note [Configuring Inductive-to-Digital-Converters for Parallel Resistance \(\$R_p\$ \) Variation in L-C Tank Sensors](#), enable the proper configuration of the relevant LDC device.

IMPORTANT NOTICE

Texas Instruments Incorporated and its subsidiaries (TI) reserve the right to make corrections, enhancements, improvements and other changes to its semiconductor products and services per JESD46, latest issue, and to discontinue any product or service per JESD48, latest issue. Buyers should obtain the latest relevant information before placing orders and should verify that such information is current and complete. All semiconductor products (also referred to herein as "components") are sold subject to TI's terms and conditions of sale supplied at the time of order acknowledgment.

TI warrants performance of its components to the specifications applicable at the time of sale, in accordance with the warranty in TI's terms and conditions of sale of semiconductor products. Testing and other quality control techniques are used to the extent TI deems necessary to support this warranty. Except where mandated by applicable law, testing of all parameters of each component is not necessarily performed.

TI assumes no liability for applications assistance or the design of Buyers' products. Buyers are responsible for their products and applications using TI components. To minimize the risks associated with Buyers' products and applications, Buyers should provide adequate design and operating safeguards.

TI does not warrant or represent that any license, either express or implied, is granted under any patent right, copyright, mask work right, or other intellectual property right relating to any combination, machine, or process in which TI components or services are used. Information published by TI regarding third-party products or services does not constitute a license to use such products or services or a warranty or endorsement thereof. Use of such information may require a license from a third party under the patents or other intellectual property of the third party, or a license from TI under the patents or other intellectual property of TI.

Reproduction of significant portions of TI information in TI data books or data sheets is permissible only if reproduction is without alteration and is accompanied by all associated warranties, conditions, limitations, and notices. TI is not responsible or liable for such altered documentation. Information of third parties may be subject to additional restrictions.

Resale of TI components or services with statements different from or beyond the parameters stated by TI for that component or service voids all express and any implied warranties for the associated TI component or service and is an unfair and deceptive business practice. TI is not responsible or liable for any such statements.

Buyer acknowledges and agrees that it is solely responsible for compliance with all legal, regulatory and safety-related requirements concerning its products, and any use of TI components in its applications, notwithstanding any applications-related information or support that may be provided by TI. Buyer represents and agrees that it has all the necessary expertise to create and implement safeguards which anticipate dangerous consequences of failures, monitor failures and their consequences, lessen the likelihood of failures that might cause harm and take appropriate remedial actions. Buyer will fully indemnify TI and its representatives against any damages arising out of the use of any TI components in safety-critical applications.

In some cases, TI components may be promoted specifically to facilitate safety-related applications. With such components, TI's goal is to help enable customers to design and create their own end-product solutions that meet applicable functional safety standards and requirements. Nonetheless, such components are subject to these terms.

No TI components are authorized for use in FDA Class III (or similar life-critical medical equipment) unless authorized officers of the parties have executed a special agreement specifically governing such use.

Only those TI components which TI has specifically designated as military grade or "enhanced plastic" are designed and intended for use in military/aerospace applications or environments. Buyer acknowledges and agrees that any military or aerospace use of TI components which have **not** been so designated is solely at the Buyer's risk, and that Buyer is solely responsible for compliance with all legal and regulatory requirements in connection with such use.

TI has specifically designated certain components as meeting ISO/TS16949 requirements, mainly for automotive use. In any case of use of non-designated products, TI will not be responsible for any failure to meet ISO/TS16949.

Products

Audio	www.ti.com/audio
Amplifiers	amplifier.ti.com
Data Converters	dataconverter.ti.com
DLP® Products	www.dlp.com
DSP	dsp.ti.com
Clocks and Timers	www.ti.com/clocks
Interface	interface.ti.com
Logic	logic.ti.com
Power Mgmt	power.ti.com
Microcontrollers	microcontroller.ti.com
RFID	www.ti-rfid.com
OMAP Applications Processors	www.ti.com/omap
Wireless Connectivity	www.ti.com/wirelessconnectivity

Applications

Automotive and Transportation	www.ti.com/automotive
Communications and Telecom	www.ti.com/communications
Computers and Peripherals	www.ti.com/computers
Consumer Electronics	www.ti.com/consumer-apps
Energy and Lighting	www.ti.com/energy
Industrial	www.ti.com/industrial
Medical	www.ti.com/medical
Security	www.ti.com/security
Space, Avionics and Defense	www.ti.com/space-avionics-defense
Video and Imaging	www.ti.com/video

TI E2E Community

e2e.ti.com