

FIT Rate, Failure Mode Distribution LM61440-Q1

Automotive 3-V to 36-V, 4-A, Low-Noise Synchronous Step-Down Converter

Functional Block Diagram

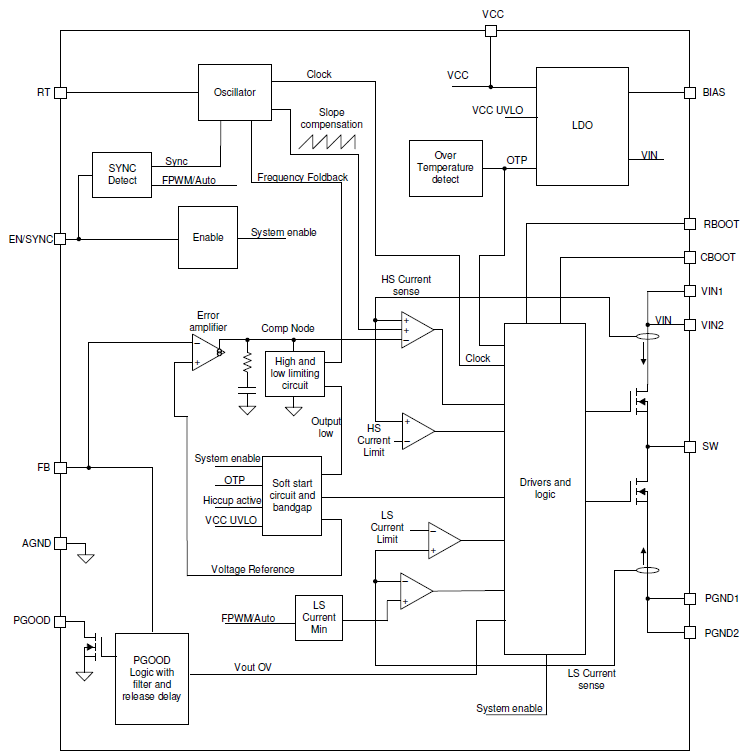

Failure Rate Mission Profile (1)	Per 10 ⁹ Hours (FIT)
Total FIT Rate	16
Die FIT Rate	8
Package FIT Rate	8

Failure Modes	Failure Mode Distribution (%)
SW No output	45%
SW output not in specification – voltage or timing	40%
SW power FET stuck on	5%
PGOOD false trip, fails to trip	5%
Short circuit any two pins	5%

(1) Failure Rate, Mission Profile and Failure Modes Distribution

The failure rate and mission profile information comes from the Reliability data handbook IEC TR 62380 using the reliability modeling for Integrated circuits with automotive motor control mission profiles

Mission Profile: Automotive Motor Control from Table 11

Power dissipation 500mW

Climate type: World-wide Table 8

Package factor lambda 3 Table 17b

Substrate Material: FR4

EOS FIT rate assumed = 0

The failure mode distribution estimation comes from the combination of common failure modes listed in standards such as IEC 61508 and ISO 26262, the ratio of sub-circuit function size and complexity and from best engineering judgment. The failure rates listed reflect random failure events and do not include failures due to misuse or over stress.

LM61440-Q1 are catalog product and not compliant to ISO-26262 standards.

IMPORTANT NOTICE AND DISCLAIMER

TI PROVIDES TECHNICAL AND RELIABILITY DATA (INCLUDING DATASHEETS), DESIGN RESOURCES (INCLUDING REFERENCE DESIGNS), APPLICATION OR OTHER DESIGN ADVICE, WEB TOOLS, SAFETY INFORMATION, AND OTHER RESOURCES "AS IS" AND WITH ALL FAULTS, AND DISCLAIMS ALL WARRANTIES, EXPRESS AND IMPLIED, INCLUDING WITHOUT LIMITATION ANY IMPLIED WARRANTIES OF MERCHANTABILITY, FITNESS FOR A PARTICULAR PURPOSE OR NON-INFRINGEMENT OF THIRD PARTY INTELLECTUAL PROPERTY RIGHTS.

These resources are intended for skilled developers designing with TI products. You are solely responsible for (1) selecting the appropriate TI products for your application, (2) designing, validating and testing your application, and (3) ensuring your application meets applicable standards, and any other safety, security, or other requirements. These resources are subject to change without notice. TI grants you permission to use these resources only for development of an application that uses the TI products described in the resource. Other reproduction and display of these resources is prohibited. No license is granted to any other TI intellectual property right or to any third party intellectual property right. TI disclaims responsibility for, and you will fully indemnify TI and its representatives against, any claims, damages, costs, losses, and liabilities arising out of your use of these resources.

TI's products are provided subject to TI's Terms of Sale (www.ti.com/legal/termsofsale.html) or other applicable terms available either on ti.com or provided in conjunction with such TI products. TI's provision of these resources does not expand or otherwise alter TI's applicable warranties or warranty disclaimers for TI products.

Mailing Address: Texas Instruments, Post Office Box 655303, Dallas, Texas 75265
Copyright © 2020, Texas Instruments Incorporated