

# TMS320TCI6482 Design Guide and Migration from TMS320TCI100

Rick Hennessy and Douglas Harrington

Digital Signal Processing Solutions

## ABSTRACT

This document describes system design considerations for the TMS320TCI6482 (TCI6482). It also gives comparisons to designing with the TMS320TCI100 (TCI100) for those familiar with that device. The objective of this document is to cover system design considerations for the TCI6482. Those familiar with the TCI100 can use the comparisons to migrate a TCI100 design to the TCI6482. In some cases there is information overlapping with the TCI6482 data manual. If the information does not match the data manual information takes precedence.

## Contents

1	TCI6482 Documentation .....	3
2	Device Overview with Comparison to the TCI100.....	3
3	Device Identification (ID).....	5
4	Pin and Package Compatibility .....	5
5	Device Configurations and Initialization .....	6
6	Clocking.....	8
7	Power Supply .....	14
8	I/O Buffers.....	21
9	Peripheral Section .....	22
Appendix A	TCI6482 RGMII 1.5V/1.8V to 2.5V/3.3V Translation .....	40

## List of Figures

1	CLKIN1, CLKIN2 Single Device Clock Solution.....	10
2	PLL1, PLL2 Multiple Device Clock Solution .....	11
3	RIOCLK Single Device LVDS Clock Solution .....	12
4	RIOCLK Multiple Devices LVDS Clock Solution .....	12
5	RIOCLK Multiple Devices LVDS Clock Solution .....	13
6	RIOCLK Multiple Devices LVPECL Clock Solution.....	13
7	Power Supply Generation.....	15
8	Recommended Power Supply Filter .....	16
9	Reference Voltage Generation .....	16
10	Multiple DSP Remote Sense Connections .....	18
11	Single DSP Remote Sense Connections .....	19
12	McBSP 8 Load Routing Topology .....	27
13	HSTL to LVCMOS Translation .....	35
14	VLYNQ Clock Divider Example .....	37
A-1	RGMII Voltage Level Translation Circuit .....	40
A-2	VOUT vs VIN .....	42
A-3	125MHz Signal from A2 to B2 and From B3 to A3 .....	43

## List of Tables

1	TCI6482 Features, Comparison to TCI100 Processor.....	4
---	---	---

---

2	TCI6482 and TCI100 JTAG (BSDL) IDs.....	5
3	Pin and Package Differences .....	6
4	Clocking Differences between TCI6482 and TCI100 .....	8
5	Reference Clock Requirements .....	9
6	Power Supply Differences .....	14
7	Die Voltage Monitor Pins.....	18
8	Bulk Capacitor Examples .....	20
9	Capacitor Recommendations.....	20
10	PTV Compensated Interfaces .....	22
11	EMIFA Comparison: TCI6482 vs TCI100 .....	24
12	HPI Comparison: TCI6482 vs TCI100.....	25
13	PCI Comparison: TCI6482 vs TCI100.....	26
14	McBSP Comparison: TCI6482 vs TCI100 .....	27
15	VCP2 Summary of Changes on TCI6482.....	28
16	VCP2 Usage Change on TCI6482.....	28
17	VCP2 Register Changes on TCI6482 .....	29
18	TCP2 Summary of Changes on TCI6482.....	29
19	TCP2 Usage Change on TCI6482 .....	30
20	TCP2 Register Changes on TCI6482 .....	30
21	GPIO/Interrupt Comparison: TCI6482 vs TCI100.....	31
22	Timer Comparison: TCI6482 vs TCI100 .....	32
23	SRIO PLL Multiplier Settings .....	37
24	JTAG/Emulation Comparison: TCI6482 vs TCI100.....	39

## 1 TCI6482 Documentation

The following is a list of available documents relevant to a TCI6482 based design:

- Data Manual
  - *TMS320TCI6482 Communications Infrastructure Digital Signal Processor*, ([SPRS246](#)). Referred to in this document as the TCI6482 data manual.
- User Guides / Reference Manuals
  - *TMS320C64x/C64x+ DSP CPU and Instruction Set Reference Guide* ([SPRU732](#))
  - *TMS320C64x+ Megamodule Reference Guide* ([SPRU871](#))
  - *TMS320C64x+ DSP Cache User's Guide* ([SPRU862](#))
  - *TMS320C6000 Programmer's Guide* ([SPRU198](#))
  - *TMS320TCI648x DSP PLL Controller Reference Guide* (SPRU806)
  - *TCI648x DSP External Memory Interface (EMIF) Reference Guide* (SPRU925)
  - *TMS320TCI6482 Bootloader User's Guide*
  - *TMS320TCI6482 Preliminary Power Consumption Summary*
  - *TCI648x DSP UHPI User's Guide* (SPRU874)
  - *TCI648x DSP PCI Reference Guide* (SPRUE60)
  - *TMS320C6000 DSP Multichannel Buffered Serial Port (McBSP) Reference Guide* ([SPRU803](#))
  - *TMS320TCI648x DSP Viterbi-Decoder Coprocessor (VCP) Reference Guide* (SPRUE09)
  - *TMS320TCI648x DSP Turbo-Decoder Coprocessor (TCP) Reference Guide* (SPRUE10)
  - *TCI648x DSP General-Purpose Input/Output (GPIO) User's Guide* (SPRU725)
  - *TMS320TCI648x DSP 64-Bit Timer User's Guide* (SPRU818)
  - *TMS320TCI648x DSP Enhanced DMA (EDMA) Controller User's Guide* (SPRU727)
  - *TCI6482 DSP Inter-Integrated Circuit (I<sup>2</sup>C) Module User's Guide* (SPRUE11)
  - *TMS320TCI648x DSP Ethernet Media Access Controller (EMAC)/Management Data Input/Output (MDIO) User's Guide* (SPRUE12)
  - *TMS320TCI648x DSP Universal Test and Operations PHY Interface for ATM 2 (Utopia2) User's Guide*(SPRU726)
  - *Serial RapidIO User's Guide* ([SPRUE13](#))
  - *TMS320TCI648x DSP DDR2 Memory Controller User's Guide* (SPRU894)
  - *High Speed DSP Systems Design Reference Guide* ([SPRU889](#))
  - *60-Pin Emulation Header Technical Reference* ([SPRU655A](#))
- Application Notes
  - *EDMA v3.0 (EDMA3) Migration Guide for TMS320TCI648x DSP* ([SPRAAC1](#))
  - *Implementing Serial Rapid I/O PCB Layout on a TMS320TCI6482 Hardware Design* ([SPRAAB0](#))
  - *Implementing DDR2 PCB Layout on the TMS320TCI6482* ([SPRAAA9](#))
  - *Using IBIS Models for Timing Analysis* ([SPRA839](#))
- Misc
  - TCI6482 IBIS Model File
  - TMS320TCI6482 BSDL file

## 2 Device Overview with Comparison to the TCI100

A high level comparison of the TCI6482 and TCI100/TCI100Q features is given in [Table 1](#). This table does not cover software differences. For more detailed comparisons of peripherals refer to the peripheral sections later in this document.

**Table 1. TCI6482 Features, Comparison to TCI100 Processor**

Hardware Features	TCI6482		TCI100/TCI100Q	
Peripherals Not all peripheral pins are available at the same time. (For more details, see the Device Configuration section of the device data manual)	EMIFA (64-bit data bus) (Clock source = AECLKIN or SYSClk4) (Supports SBSRAM, SRAM, Sync FIFOs, Async memories; SRAM, ROM, Flash)	1	EMIFA (64-bit data bus) (Clock source = AECLKIN, CPU/4, CPU/6) (Supports SBSRAM, SRAM, Sync FIFOs, Async memories; SRAM, ROM, Flash)	1
	DDR Memory Controller EMIF (32-bit data bus width) [1.8V IO] (Clock source = generated from PLL2)	1	EMIFB (16-bit bus width) (supports SDRAM and programmable sync)	N/A
	EDMA3 (64 independent channels) [CPU/3 clock rate]	1	EDMA2	1
	High-speed 1x/4x Serial Rapid IO Port	1	N/A	N/A
	HPI (32 or 16-bit user selectable)	1	same	1
	PCI (32-bit) [66-MHz or 33-MHz]	1	PCI (32-bit) [33-MHz]	1
	McBSP (Internal clock source up to 90 MHz)	2	McBSP	3
	UTOPIA (8-bit mode, 50-MHz, Slave-only)	1	Same	
	10/100/1000 Ethernet MAC (EMAC)	1	N/A	N/A
	Management Data Input/Output (MDIO)	1	N/A	N/A
	64-bit Timers (Configurable) (Internal clock source: CPU Clock/6, External clock source up to CPU clock/24)	2 - 64-bit or 4-32-bit	32-bit Timer	3-32 bit timers
	VLYNQ	1	N/A	N/A
	General Purpose Input/Output (all can be used as external interrupts)	16	General Purpose Input/Output (4 can be used as external interrupts)	16
Decoders Coprocessors	VCP2	1	VCP	1
	TCP2	1	TCP	1
	RSA	1	N/A	N/A
On-Chip Memory	L1P (Configurable as cache and SRAM)	32K-Byte	L1P (Cache only)	16K-Byte
	L1D (Configurable as cache and SRAM)	32K-Byte	L1D (Cache only)	16K-Byte
	L2	2048K-Byte	L2	1024K-Byte
CPU MegaModule Revision ID	Revision ID Register (MM_REVID[15:0]) Byte address = 0x01812000	Read value: 0x0 (silicon revision 1.1)	N/A	N/A

**Table 1. TCI6482 Features, Comparison to TCI100 Processor (continued)**

JTAG BSDL_ID	JTAGID register	Read value: 0x0008A02F	JTAGID register	Read value: 0x008102F
Frequency	Core clock	Up to 1-GHz	Core clock	720MHz, 850MHz
Voltage	Core Supply	1.2V	Core Supply	1.2V
	IO Supplies	3.3V, 1.8V (1.5), 1.2V	IO Supply	3.3V
PLL and PLL controller Options	PLL1 for Core Clock (Software configurable) PLL2 for DDR/EMAC Clock		PLL for Core Clock (Hardware configurable)	
BGA Package	697-Pin BGA Package, 0.8mm pitch, 24mmx24mm	ZTZ Suffix	532-Pin BGA Package, 0.8mm pitch, 23x23mm	GLZ Suffix
Process Technology	0.09um/7-Level Cu Metal Process (CMOS)		0.09um/7-Level Cu Metal Process (CMOS)	
Device Part Numbers	TMX320TCI6482ZTZ		TMS320TCI100GLZ	

### 3 Device Identification (ID)

The JTAG (BSDL) ID and Silicon Revision ID are different than other TMS320C64x DSP devices. The TCI6482 device IDs are shown in the table below and are referred to as JTAG (BSDL) IDs. The JTAG (BSDL) ID is accessible via JTAG on both devices and through the JTAG ID register at address 0x02A80008 on the TCI6482 device.

Table 2 identifies the JTAG (BSDL) ID differences between the TCI100 and TCI6482.

**Table 2. TCI6482 and TCI100 JTAG (BSDL) IDs**

JTAG (BSDL) ID				
Device	Variant [31:28]	Part Number [27:12]	Manufacturer [11:1]	LSB
TCI6482	xxxxb <sup>(1)</sup>	0000000010001010b	00000010111b	1 [0]
TCI100	xxxxb <sup>(2)</sup>	0000000010000001b	00000010111b	1

<sup>(1)</sup> Variant field indicates the silicon version. Refer to the data manual and errata for current silicon versions.

<sup>(2)</sup> Variant field indicates the silicon version. Refer to the data manual and errata for current silicon versions.

The TCI6482 does not have a Silicon Revision ID as found in the TCI100.

### 4 Pin and Package Compatibility

The physical dimensions and pin out of package used for TCI6482 will be different from TCI100. Modification will be needed to account for the different physical dimensions of package and pin out. Changes in substrate may also affect the thermal characteristics of the package used for TCI6482. See the *TMS320TCI6482 Communications Infrastructure Digital Signal Processor (SPRS246)* for additional information regarding package characteristics.

**Table 3. Pin and Package Differences**

Device	Package Type (s)	Pin Count
TCI100	GLZ Ball Grid Array (BGA) 0.8mm pitch, 23 x 23 mm	532
TCI6482	ZTZ Ball Grid Array (BGA) 0.8mm pitch, 24 x 24 mm	697

## 5 Device Configurations and Initialization

On the TCI6482 device, bootmode and certain device configuration/peripheral selections are determined at device reset, while peripheral usage (enabled/disabled) is determined by the Peripheral Configuration registers after the device reset. The peripherals on the TCI6482 device are “disabled” and need to be “enabled”. This is different than the TCI100 in which case the peripherals selected by the boot strap options were enabled on power-up. The basic information on configuration options, boot modes options and use of the Power Configuration registers can be found in the TCI6482 data manual.

### 5.1 Device Reset

There are several ways to reset the TCI6482 and these are described in the TCI6482 data manual. The two external resets,  $\overline{\text{POR}}$  and  $\overline{\text{RESET}}$ , need to be driven to a valid logic level at all times.  $\overline{\text{POR}}$  must be asserted (low) on a power-up while the clocks and power planes become stable.  $\overline{\text{RESET}}$  can be used from the powered up state to issue a warm reset, which performs the same as a  $\overline{\text{POR}}$  except that test and emulation logic are not reset. If a warm reset is not needed,  $\overline{\text{RESET}}$  can be pulled up to DVDD33.

In revision 1.1 silicon, when  $\overline{\text{POR}}$  is held low the internal pull-up and pull-down resistors are disabled. This requires the use of external pull-up and pull-down resistors for all pins that have their states latched by  $\overline{\text{POR}}$ . Alternatively, after  $\overline{\text{POR}}$  is de-asserted long enough for the internal resistors to pull voltage levels to valid states (> 100uS) bringing  $\overline{\text{RESET}}$  low for at least 24 CLKIN1 cycles and then high again will allow re-latching the state of the configuration strapping with valid values from the internal pull-ups, pull-downs. While  $\overline{\text{POR}}$  is low, large currents may be seen on the DVDD33 power plane due to floating inputs (i.e. the EMIF bus). If the user wishes to avoid these currents external pull-ups or pull-downs should be used. Refer to the TCI6482 Silicon Errata document for complete details. In revision 2.0 silicon and later the internal pull-up and pull-down resistors will not be disabled under any conditions.

The RESETSTATz signal indicates the internal reset state. The RESETSTATz is asserted (low) on a power-on reset, warm reset, max reset, or system reset. The only reset that does not cause RESETSTATz to be asserted is a CPU reset (issued from the PCI peripheral).

### 5.2 Device Configuration

The TCI6482 device configuration options are multiplexed on the EMIFA address AEA[19:0] and EMIFA bank address lines ABA[1:0]. There is one dedicated configuration pin, PCI\_EN. Refer to the TCI6482 data manual for details on the configuration options. All reset strapping pins have internal pull-ups or pull-downs in the range of 30K ohms. If the EMIFA bus is not used the internal pull-ups and pull-downs can be used and an external pull-up/down is only needed if the opposite setting is desired. If the configuration pins are routed out from the device, the internal pullup/pulldown resistor should not be relied upon; 1K pull-ups and pull-downs are recommended for all desired settings.

The core clock PLL multiplier is not set by reset configuration strapping as it was on the TCI100. The PLL multiplier can only be set by CPU register writes. The registers are not accessible through boot peripherals. The core clock speed when accessing the internal ROM must be not more than 750MHz. PCI and Serial RapidIO boot modes automatically change the PLL multiplier to 15X, so the CLKIN1 must be no more than 50MHz. For other boot modes it is suggested to set the multiplier early in the boot process in order to reduce boot times. For details on setting the CLKIN1 PLL multiplier and divider settings refer to section 6.1 and the *TMS320TCI648x DSP PLL Controller Reference Guide* (SPRU806).

### 5.3 Peripheral Configuration

Other than the device reset configuration covered in [Section 5.1](#), all other configurations are done by register accesses. The first step to configuring a peripheral is to enable it using Peripheral Configuration Register 0 and 1. Since all peripherals not needed for the selected boot mode are disabled, a first level boot loader may be needed to enable interfaces needed during the full boot load. For example, if the application code to be loaded (.OUT file) loads data into an external memory, a first level boot loader must be loaded and executed to enable the EMIF interface. If the Boot Mode selection specifies a particular interface for boot, it is automatically enabled and configured. Note that Peripheral Configuration Register 0 and 1 are only accessible by the CPU, therefore, it is not possible to configure these registers directly through a host interface like the HPI and PCI. For more details on peripheral configuration refer to the Device Configuration section of the TCI6482 data manual.

The EMAC interface requires some PLL2 configurations. The specific settings are dependent on the MII mode. For details on PLL2 configuration refer to the *TMS320TCI648x DSP PLL Controller Reference Guide* (SPRU806).

For some peripherals, the peripheral operating frequency is dependent on the CPU core clock frequency. This should be accounted for when configuring the peripheral.

All other peripheral configurations are done within the peripheral module. For configuring the peripheral module refer to the specific peripheral's user guide.

### 5.4 Configuration Tables in I2C ROM

I2C ROM contents can contain Configuration Tables which allow customer defined memory map accesses during the I2C boot mode. These accesses can be used to configure peripherals during the boot process. For details refer to the *TMS320TCI6482 Bootloader User's Guide* document.

### 5.5 Boot Modes

The interfaces which support a boot loading process are: I2C, HPI, PCI, Serial RapidIO and EMIF (8-bit ROM). In addition, a first level boot loader (loaded using one of those interfaces) can configure the Ethernet or Utopia interfaces for a secondary boot load. For a summary of the boot modes supported refer to the TCI6482 data manual. For details regarding boot modes, refer to the *TMS320TCI6482 Bootloader User's Guide* document.

Regardless of the boot mode selected, an emulator connection can always reset the device to acquire control.

If the PCI interface is enabled, it supports an optional auto-initialization feature which will load the PCI config registers from an I2C ROM before the boot load is performed.

### 5.6 Boot/Initialization Sequence

Generic bring up procedure:

1. Follow power-up and reset sequencing per the TCI6482 data manual.
2. When the  $\overline{\text{POR}}$  (or  $\overline{\text{RESET}}$  on a warm boot) signal is de-asserted the boot strapping options are latched and the boot mode selection controls what happens next:
  - a. If the PCI interface is selected and auto-initialization is enabled, the auto-initialization is performed
  - b. Booting over I2C loads code contents into L2, code is executed after last code section is copied
  - c. Booting over EMIF starts executing from the base address of CE3 space
  - d. Booting over HPI, PCI or Serial RapidIO puts the device in a state that waits for code to be copied through those interfaces into L2 and an interrupt to initiate the execution of that code.
3. Boot code (at a minimum) should configure the PLL1 core clock frequency and also enable and configure the required peripherals and:
  - a. PCI and SerialRapidIO boot modes configure the PLL1 for a 15x multiplier to allow proper operation of those interfaces. After the boot load is completed, application code should change the PLL1 to final desired multiplier. Due to the use of the 15x multiplier, the CLKIN1 should be no greater than 50MHz when selecting the PCI or SerialRapidIO boot modes.

## 6 Clocking

### 6.1 PLLs

#### 6.1.1 Clock PLL and PLL Controller

A description of the PLLs and PLL controllers along with register definitions can be found in the *TMS320TCI6482 Communications Infrastructure Digital Signal Processor* (SPRS246). [Table 4](#) shows the clocking differences between the TCI6482 and the TCI100.

**Table 4. Clocking Differences between TCI6482 and TCI100**

Device	PLL Type	Input Clock Range	Frequency Multiplication Factors	Program Multiplier via	Clock Input Source	Purpose
TCI100	Analog PLL	42MHz - 75MHz <sup>(1)</sup>	x1, x6, x12, x20	HW config	External clock input	CPU clock
TCI6482	Analog PLL (Main device clock)	33 MHz - 66MHz <sup>(2)(1)</sup>	x15, x20, x25, x30, x32	SW config	External clock input	CPU clock
TCI6482	Analog PLL (Used for DDR2 and EMAC clocking)	12.5MHz - 26MHz	x10	N/A	External clock input	DDR2 and Ethernet (except MII) <sup>(3)</sup>

(1) Supported frequency range and multipliers may change. Refer to the data manual for the latest information.

(2) Clock range is limited to 50MHz if using PCI or SerialRapidIO boot modes.

(3) In silicon version 2.0 and all subsequent versions this PLL is not required for RMII operation.

#### 6.1.2 PLL Operation

The PLL1 controller powers up in bypass (x1) mode with PLL1 in reset. Some boot modes change this multiplier (see [Section 5.6](#)). After the PLL1 is out of reset and running, changing the PLL1 controller multiplier and divider values (or the reference clock frequency) involves using the PLL reset mode to clear the lock condition.

The PLL reset mode is used under the following conditions:

- After power is applied, the PLL is automatically placed in reset mode
- To change the input frequency (CLKIN1)
- To change the value in any divider or multiplier register

The procedures for changing the PLL are described in [Section 6.1.3](#) and [Section 6.2](#).

#### 6.1.3 PLL Configuration after Power-Up

The following process should be followed to set the PLL multiplier after power-on reset. The wait times are conservative durations to guarantee proper operation.

1. Allow PLL1 to become stable, see the device data manual for stabilization time.
2. Program PLLCTL.PLLENSRC=0 to enable the PLLCTL.PLLEN bit.
3. Program PREDIV, PLLM for the desired multiplier and divider.
4. Set PLLRST=0 to de-assert PLL reset.
5. Wait for 3000 CLKIN1 cycles for the PLL to lock.
6. Set PLLEN=1 to switch from Bypass mode to PLL mode.



## 6.2 PLL Configuration During Operation

The following process should be followed to change the PLL after it has been operating. The wait times are conservative durations to guarantee proper operation.

1. Program PLLCTL.PLLENSRC=0 to enable the PLLTL.PLLEN bit.
2. Program PLLEN=0 (PLL bypass mode) and PLLRST=1 (reset PLL) in PLLCTL register.
3. Program PREDIV, PLLM for the desired multiplier and divider.
4. Wait for at least 256 CLKIN1 cycles for the PLL to reset.
5. Set PLLRST=0 to de-assert PLL reset.
6. Wait for 3000 CLKIN1 cycles for the PLL to lock.
7. Set PLLEN=1 to switch from Bypass mode to PLL mode.

## 6.3 PLL1, PLL2, and SRIO Reference Clock Solutions

This section describes the clock requirements and a system solution for the input clocks to the TCI6482 device that require special consideration. CLKIN1 is the reference clock to PLL1 which is used to generate the core clock (up to 1GHz). This clock requires a low jitter clock source. CLKIN2 is the reference clock to PLL2 which is used to generate the clock for the DDR2 and EMAC subsystems. This clock, when used as the reference clock to the DDR2 subsystem, must be low jitter. The SRIO reference clock (RIOCLK, RIOCLK) requires a differential low jitter clock source and proper termination.

It is also assumed that multiple TMS320TCI6482 devices may be used on a board so the proposed system solutions include clock fanout buffers.

### 6.3.1 Clock Requirement

The clock requirements are given in [Table 5](#).

**Table 5. Reference Clock Requirements**

	Logic	Input Jitter <sup>(1)</sup>	Trise/Tfall	Duty Cycle	Stability	Freq <sup>(2)</sup>	PLL Freq
CLKIN1	LVC MOS or LV TTL	100pS pk-pk	Max 1.2nS	40/60%	50PPM	50MHz	1GHz
CLKIN2	LVC MOS or LV TTL	100pS pk-pk	Max 1.2nS	40/60%	50PPM	25MHz	250MHz
RIOCLK, RIOCLK	Differential LVDS or LVPECL	4pS RMS 56ps pk-pk @ 1x10E <sup>-12</sup> BER	50pS - 700pS	45/55%	50PPM	125MHz, 156.25MHz	3.125GHz

<sup>(1)</sup> Assumes a Gaussian distribution. Peak-peak jitter assumes 100,000 points.

<sup>(2)</sup> Recommended operating frequencies based on component availability and supported PLL multipliers.

Trise/Tfall values are given for CLKIN1 and CLKIN2 transitions from 0.8V to 2.0V. This is equivalent to a max Trise/Tfall of 2nS from 20% to 80% of 3.3V. RIOCLK Trise/Tfall values are given for 20% to 80% of the voltage swing. These rise/fall times assume the maximum jitter values. Slower rise/fall times can be used if the jitter is lower.

### 6.3.2 CLKIN1/CLKIN2 Solutions

CLKIN1 and CLKIN2 have similar requirements for a clock source so the same clocking solutions (except for frequency) can be used for both.

#### 6.3.2.1 Single Device Solution

It is assumed that the source clock for each of these clocks is an oscillator on the same board as the TMS320TCI6482. Use of distributed clocks may require a jitter cleaner device such as the CDCM7005 (refer to <http://focus.ti.com/docs/prod/folders/print/cdcm7005.html>). Most PLL based clock generators do not meet the input jitter requirement. If an on-board oscillator is used with one TMS320TCI6482 no other components should be needed except for termination resistors.

For CLKIN1 and CLKIN2, a low jitter CMOS oscillator would be sufficient. A series termination resistor (nominally 22 ohms) at the source is suggested (refer to [Figure 1](#)). An example of an appropriate oscillator is:

- Vectron VCC1 series 3.3V CMOS oscillator
  - <http://www.vectron.com/products/xo/vcc1.pdf>

This oscillator has not been tested but is an example of an oscillator that meet the specification requirements for CLKIN1 and CLKIN2.

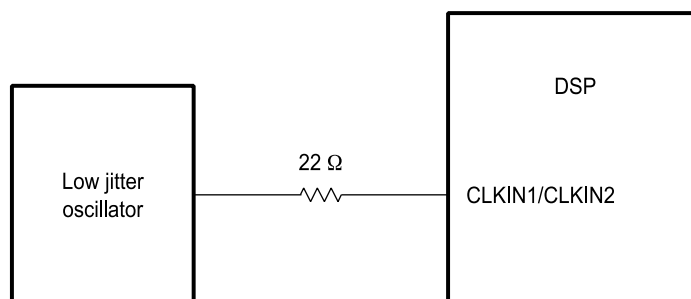

**Figure 1. CLKIN1, CLKIN2 Single Device Clock Solution**

### 6.3.2.2 Fanout Solutions

For systems with multiple TMS320TC16482 devices it may be preferred to use one oscillator and a fanout buffer instead of multiple oscillators. This would allow for fewer components as well as lower cost. The fanout buffer increases the jitter at the clock input so care must be taken in selecting the combination of oscillator and fanout buffer.

In most cases the same oscillators described in [Section 6.3.2.1](#) can be used for the fan out case. The oscillator output specifications should be compared to the fanout buffer input specifications to make sure they are compatible.

A low jitter fanout buffer is required which generally means a non-PLL based fanout buffer should be used. Suggested solutions for fanout buffers are:

- TI CDCV304 1:4 Clock buffer
  - <http://focus.ti.com/lit/ds/symlink/cscv304.pdf>
- TI CDCVF2310 1:10 Clock buffer
  - <http://focus.ti.com/lit/ds/symlink/cdcvf2310.pdf>
- CDCV304 jitter information: <http://focus.ti.com/lit/an/scaa052/scaa052.pdf>
- CDCVF2310 jitter information: <http://focus.ti.com/lit/an/scaa064/scaa064.pdf>

[Figure 2](#) shows a diagram of a solution that allows an oscillator and a fanout buffer to provide CLKIN1 or CLKIN2 for up to 4 DSPs. Up to 10 DSPs could be supported with the CDCVF2310 which would be the same circuit without the series resistors since the CDCVF2310 has built-in 22ohm resistors. The buffer outputs should not be used to drive additional fanout buffers since the jitter will accumulate.

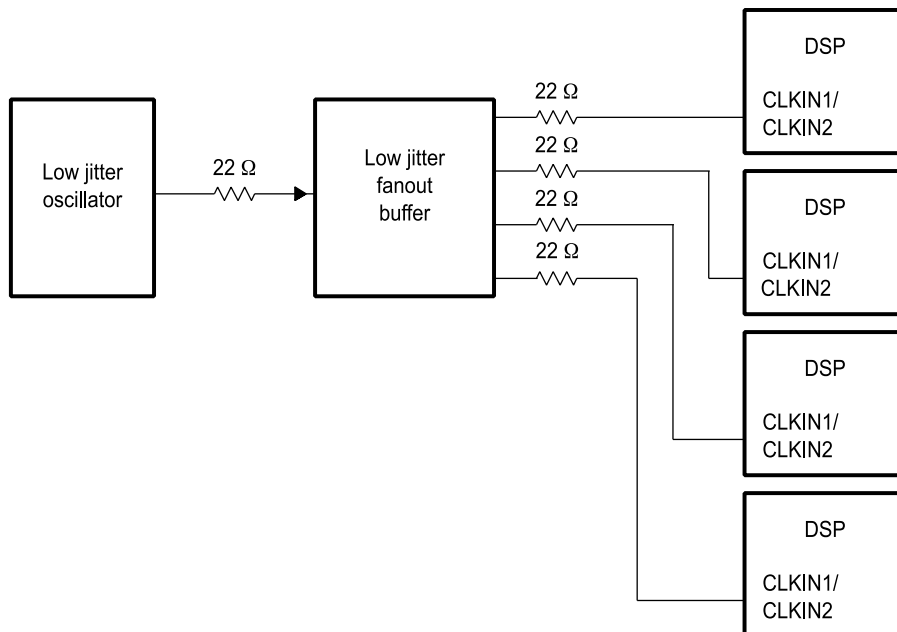

**Figure 2. PLL1, PLL2 Multiple Device Clock Solution**

Another solution would be to use very low jitter PLL clock generators/buffers. TI's CDCE706 and CDCE906 have been tested with at 25MHz and 50MHz and shown to meet the required jitter specifications.

### 6.3.2.3 Layout Recommendations

#### Placement, Terminations

- The oscillator should be placed close to the destination.
- Series termination should be placed close to clock source.
- The value of the series termination resistor should be optimized to reduce over-shoot and under-shoot while not violating the Trise/Tfall input specification. TI suggests the customer use IBIS simulations to determine the correct value of the termination resistor.

#### Trace Routing

- A GND plane should be placed below the oscillator.
- Digital signals should not be routed near or under the clock sources.
- Maintain at least 25 mil spacing to other traces.

### 6.3.3 RIOCLK/RIOCLK Solutions

The SerialRapidIO reference clock requires special considerations because it is differential, must be low jitter, and requires termination. Either an LVDS or LVPECL clock source can be used but they require different terminations. The input buffer sets its own common mode voltage so AC coupling is necessary. It also includes a 100ohm differential termination resistor, eliminating the need for an external 100ohm termination when using an LVDS driver. For generation information on AC termination schemes, refer to *AC Coupling Between Differential LVPECL, LVDS, HSTL and CML* ([scaa059](#)). For information on DC coupling refer to *DC-Coupling Between Differential LVPECL, LVDS, HSTL, and CML* ([scaa062](#)).

### 6.3.3.1 Single Device Solution

It is assumed that the source clock is an oscillator on the same board as the TMS320TCI6482. Use of distributed clocks may require a jitter cleaner device such as the CDCM7005 (refer to <http://focus.ti.com/docs/prod/folders/print/cdcm7005.html>) or the CDCL6010. If an on-board oscillator is used with one TMS320TCI6482 no other components should be needed except for terminations.

For the Serial rapid IO reference clock examples of appropriate oscillators are:

- Pletronics LVDS LV77D oscillator
  - <http://www.pletronics.com/pdf/LV77D%203.3v.pdf>
- Pletronics LVPECL PE77D oscillator
  - <http://www.pletronics.com/pdf/PE77D%203.3v.pdf>

These oscillators have not been tested but are examples of oscillators that meet the specification requirements for RIOCLK/RIOCLK.

Figure 3 shows an LVDS based solution including terminations. Figure 4 shows an LVPECL based solution including terminations. The terminations shown are still being investigated and should be considered preliminary.

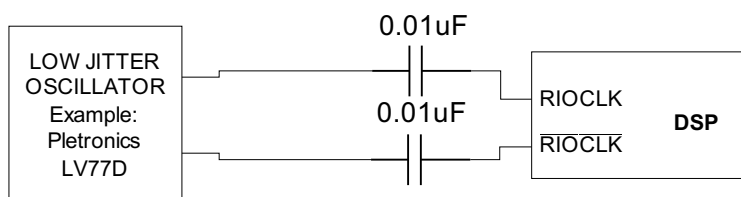

Figure 3. RIOCLK Single Device LVDS Clock Solution

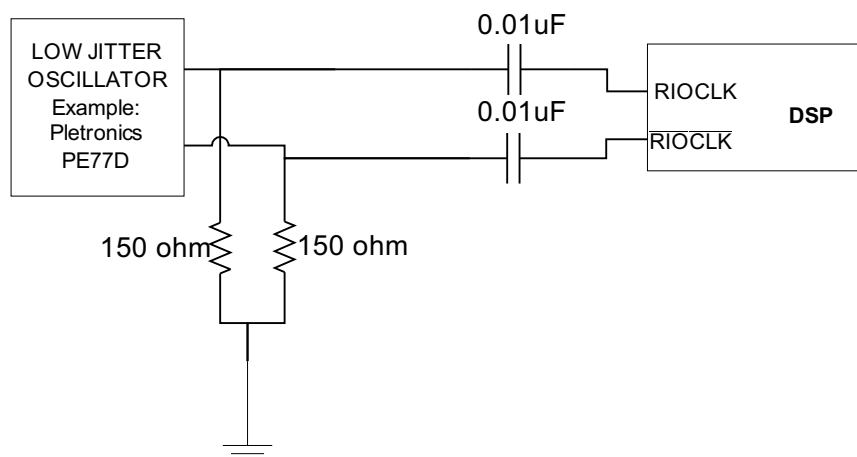

Figure 4. RIOCLK Multiple Devices LVDS Clock Solution

### 6.3.3.2 Fanout Solutions

For systems with multiple TMS320TCI6482 devices it may be preferred to use one oscillator and a fanout buffer instead of multiple oscillators. This would allow for fewer components as well as lower cost. The fanout buffer increases the jitter at the clock input so care must be taken in selecting the combination of oscillator and fanout buffer.

In most cases the same oscillators described in Section 6.3.3.1 can be used for the fan out case. The oscillator output specifications should be compared to the fanout buffer input specifications to make sure they are compatible.

A low jitter fanout buffer is required which generally means a non-PLL based fanout buffers should be used. Suggested solutions for a fanout buffers are:

- TI SN65LVDS108 LVDS 1:8 Clock fanout buffer
  - <http://focus.ti.com/lit/ds/symlink/sn65lvds108.pdf>
- TI CDCLVP110 LVPECL 2:10 Clock fanout buffer
  - <http://focus.ti.com/lit/ds/symlink/cdclvp110.pdf>

There are also 4-port and 16-port versions of the SN65LVDS108. For an integrated jitter cleaner and multiple clock output buffer the CDCL6010 can be used.

These buffers have not been tested but are examples of buffers that meet the specification requirements for RIOCLK / RIOCLK#.

Jitter performance for the SN65LVDS108 is found in its datasheet. For the CDCLVP110 the jitter characteristics of these parts refer to:

- CDCLVP110 Jitter Info: <http://focus.ti.com/lit/an/scaa068/scaa068.pdf>

Figure 5 shows a diagram of a solution that allows an LVDS oscillator and an LVDS fanout buffer to provide RIOCLK / RIOCLK# for up to 8 DSPs. Figure 6 shows an LVPECL solution for up to 10 DSPs. The fanout buffer outputs should not be used to drive additional fanout buffers since the jitter will accumulate.

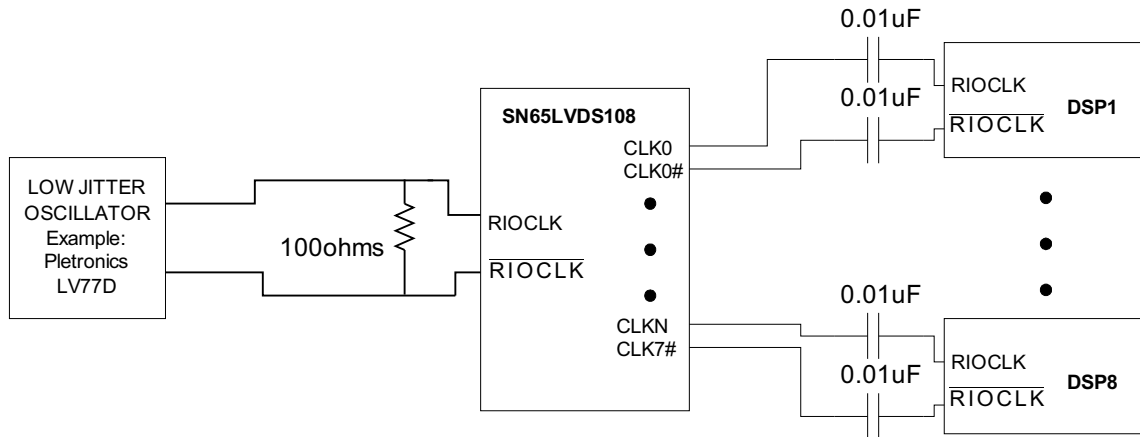

Figure 5. RIOCLK Multiple Devices LVDS Clock Solution

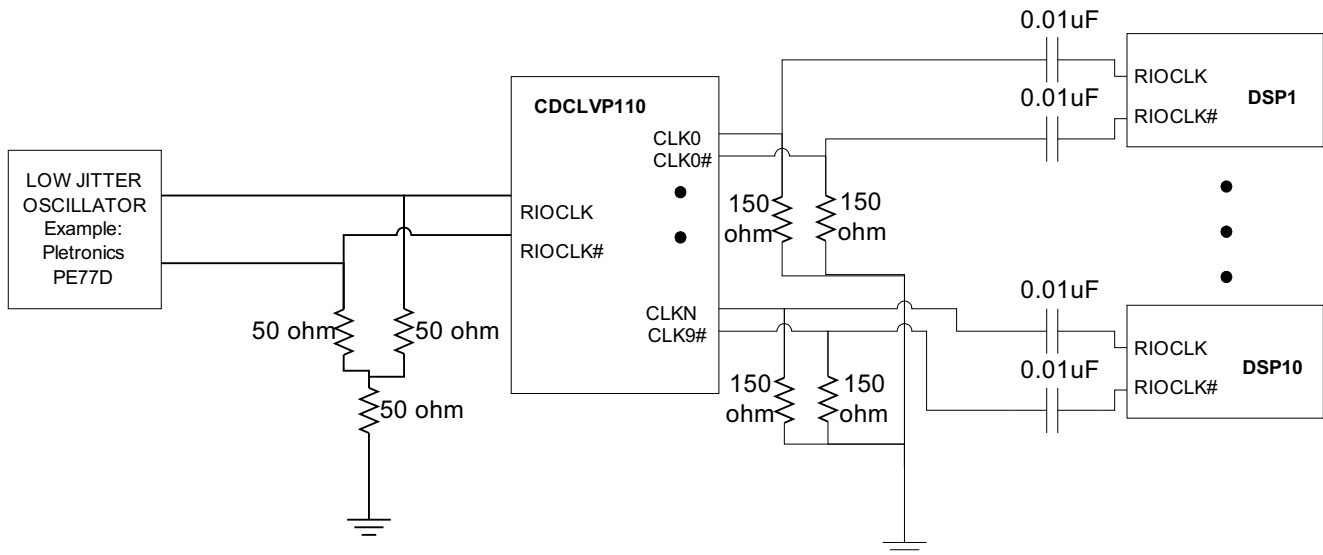

Figure 6. RIOCLK Multiple Devices LVPECL Clock Solution

### 6.3.3.3 Layout Recommendation (LVDS and LVPECL)

Placement:

- The oscillator, buffer, and DSPs should be placed as close to each other as practical
- Fanout buffers should be placed in a central area to equalize the trace lengths to each DSP
- AC coupling capacitors should be placed near the receivers
- 50ohm resistors used in LVPECL DC termination should be placed near the receiver
- 150ohm resistors used in LVPECL AC termination should be placed near the driver
- 100ohm resistors used in LVDS terminations should be placed near the receiver

Trace routing:

- A GND plane should be placed below the oscillator
- Digital signals should not be routed near or under the clock sources.
- Traces should be 100 ohm differential impedance and 50 ohm single ended impedance
- Clock routes should be routed as differential pairs with no more than 2 vias per connection (not counting pin escapes)
- The number of vias on each side of a differential pair should match
- Differential clock routes must be length matched to within 10 mils
- Maintain at least 25 mil spacing to other traces

## 7 Power Supply

A comparison of the voltages needed for the TCI6482 vs. the TCI100 is shown in [Table 6](#). For definitions for the power supplies refer to the TCI6482 data manual.

**Table 6. Power Supply Differences**

Device	Core Supply Voltage		I/O Supply Voltages (Tolerances are +/-5%)				Analog Supply Voltages (Tolerances are +/-5%)		
	CVDD	TOL	DVDD33	DVDD18	DVDD15	DVDD12 (SRIO)	PLL	DDR2 DLL	SRIO
TCI6482	1.2V	±3%	3.3V	1.8V	1.5V or 1.8V	1.2V	1.8V	1.8V	1.2V
TCI100	1.1V 1.2V	±3% ±3%	3.3V	N/A	N/A	N/A	3.3V	N/A	N/A

### 7.1 Power Plane Generation

All power supplies may be generated from switching supplies with the exception of the SRIO 1.2V supplies (DVDD12, AVDDA and AVDDT). Due to the noise sensitivity of the SRIO SERDES links a linear regulator with proper filtering is recommended. A switching regulator plus filtering can be used if the AC noise is guaranteed to be less than +/-25mV. One solution for a suitable 1.8V to 1.2V linear regulator is the UC385-ADJ (<http://focus.ti.com/lit/ds/symlink/uc385-adj.pdf>) which can support multiple DSPs. Filters are also recommended for some other voltage planes. An overview of the recommended power supply generation architecture is shown in [Figure 7](#).

The DVDD15 supply can be operated at either 1.5V or 1.8V. Operation at 1.8V will consume somewhat more power than 1.5V operation but eliminates the need for a 1.5V supply. Most Ethernet PHYs that support RGMII v2.0 operation support the HSTL interface at either 1.5V or 1.8V.

The optional power supplies are noted with dashed lines. These are power pins that can be connected directly to VSS if the associated peripheral is not used and is disabled. If power supplies for SRIO or RGMII are to be connected to VSS, care should be taken that all associated power for that interface must be connected to VSS. Removing power from these interfaces will result in the inability to boundary scan test these interfaces. Refer to the data manual for details.

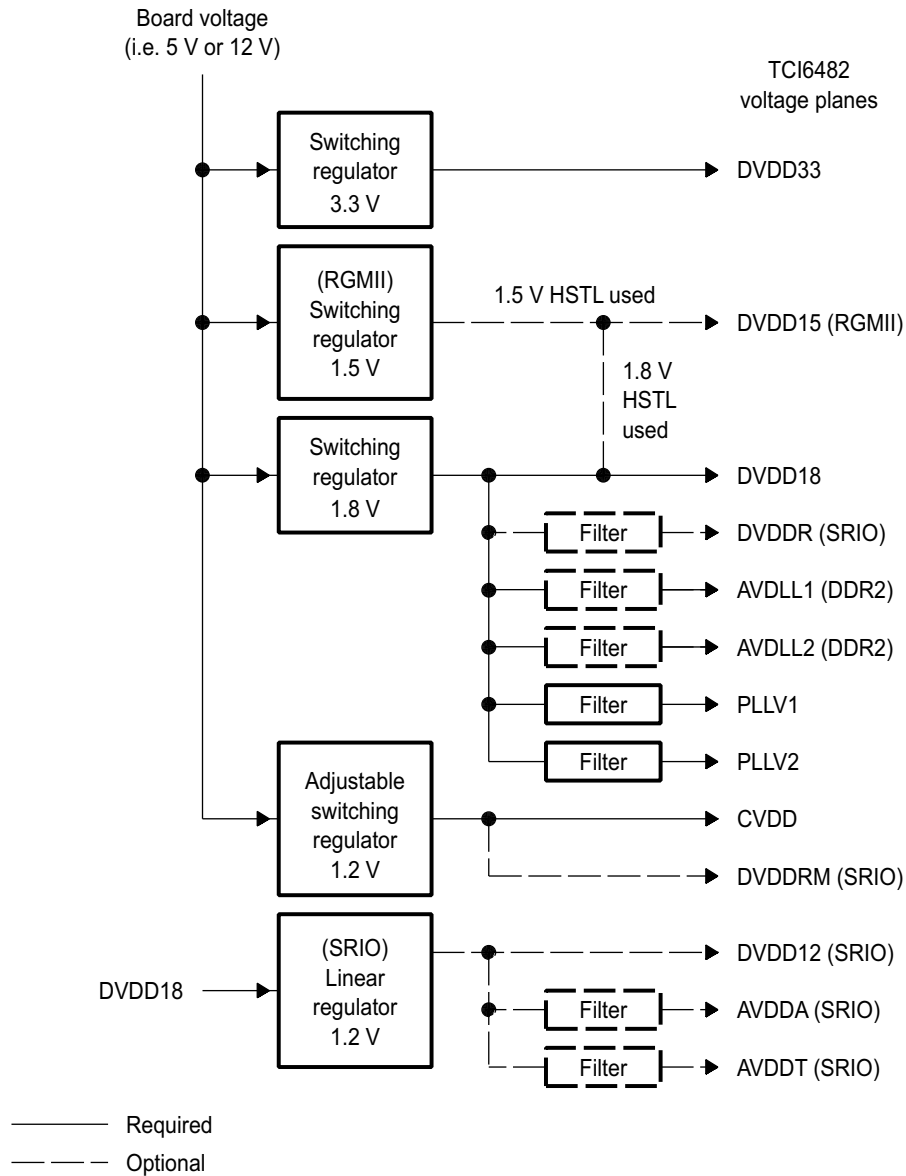

**Figure 7. Power Supply Generation**

Filters on AVDLL1 and AVDLL2 are not needed if the DDR2 interface is not used.

The recommended filter circuit from [Figure 7](#) is given in [Figure 8](#). The filter component shown is a from Murata part. If a different part is cross-referenced, the frequency envelope must be considered. This solution has been tested.

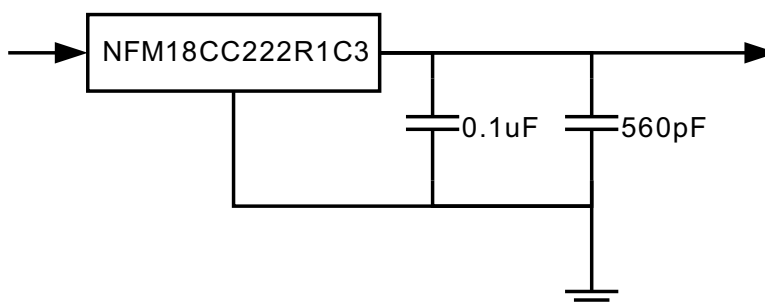

**Figure 8. Recommended Power Supply Filter**

The reference voltages used for the SSTL (DDR2) and HSTL (RGMII) interfaces are intended to operate at half the voltage supplied to those I/Os. This is done through a simple voltage divider as shown in [Figure 9](#). More details on VREFSSTL can be found in: *Implementing DDR2 PCB Layout on the TMS320TCI6482* ([SPRAAA9](#)). Note that if the RGMII interface is not used and is disabled, VREFHSTL can be connected to directly to VSS.

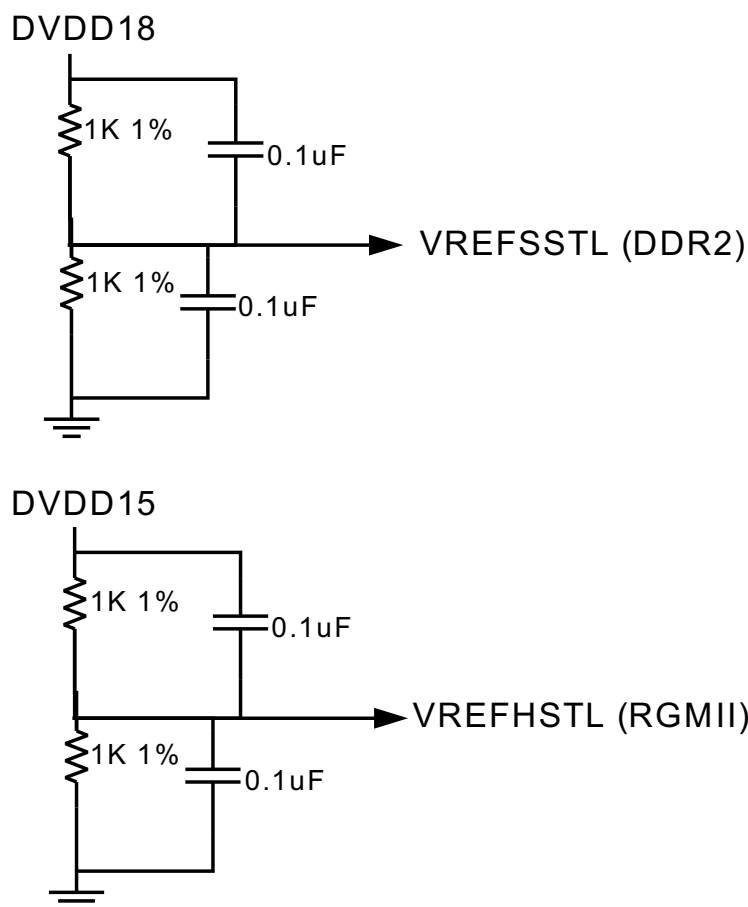

**Figure 9. Reference Voltage Generation**

## 7.2 Power Supply Sequencing [D]

The recommended power sequence is described in the TCI6482 data manual. This is the sequence which is used for manufacturing device test. Other sequences may work but have not been verified at this time. Therefore, it is strongly recommended that this sequence be followed.



Although the power sequence has 3.3V I/O ramping before the core voltage, bus contention will not occur in this case due to special circuitry that has been added that hold the 3.3V I/Os in tri-state during the power ramp-up period.

There are multiple ways to generate a controlled power sequence. A microcontroller or PLD can be used to control power supply sequencing. Alternatively, TI has power management products that can be used such as the TPS3808 (<http://focus.ti.com/lit/ds/symlink/tps3808g33.pdf>).

### 7.3 Voltage Plane Power Requirements

Power requirements are highly dependent on the usage of the device. This includes which peripherals are used as well as the operating frequencies. In order to generate an estimate of the TCI6482 power for a particular application, refer to the TMS320TCI6482 Preliminary Power Consumption Summary.

### 7.4 Power Supply Layout Recommendations

Core and I/O supply voltage regulators should be located close to the DSP (or DSP array) to minimize inductance and resistance in the power delivery path. Additionally, when designing for high-performance applications utilizing the C6000 platform of DSPs, the PCB should include separate power planes for core, I/O and ground, all bypassed with high-quality low-ESL/ESR capacitors.

For VREFHSTL and VREFSSTL, one reference voltage divider should be used for both the TCI6482 and the reference voltage input on the attached device. The same supply should also be used for the I/O voltages between the 2 parts. The VREF resistor divider should be placed between the 2 devices and the routes made as directly as possible with a minimum 20 mil wide trace. There should be a 2x trace width clearance between the routing of the reference voltage and any switching signals.

The DLL signals (AVDLL1 and AVDLL2) can be routed using minimum 15 mil wide traces. There should be a 2x trace width clearance between this and any switching signals.

The filter circuits should be placed as close to the corresponding TCI6482 power supply pin(s) as possible. No digital switching signals should be routed near or directly under the filter circuits.

### 7.5 Voltage Tolerances, Noise, and Transients

The voltage tolerances specified in the datasheet include all DC tolerances and the transient response of the power supply. These specify the absolute maximum and minimum levels that must be maintained at the pins of the TCI6482 under all conditions. Special attention to the power supply solution is needed to achieve this level of performance, especially the 3% tolerance on the core power plane (CVDD).

In order to maintain the 3% tolerance at the pins, the tolerance must be a combination of the power supply DC output accuracy, the voltage drop from the supply to the load and the effect of transients. A reasonable goal for the DC power supply output accuracy is 1.5%, leaving 1.5% for the transients. At 1.2V a 3% tolerance is +/-36mV. This allows 18mV of DC accuracy from the output of the power supply and another 18mV due to transients.

Power plane IR drop is another factor to consider, especially if there are multiple DSPs in a group on a board. Power planes, even if no splits are present, have impedance. With large currents running across the power planes the voltage drop must be considered. This same issue also applies to ground planes with heavy currents.

#### 7.5.1 Using Remote Sense Power Supplies

Use of a power supply that supports the remote sense capability allows the power supply to control the voltage at the load. Special layout care must be used to keep this sense trace from being lost during PCB layout. One solution is placement of a small resistor at the load and connecting the sense trace to the voltage plane through it. If a group of DSPs on the board are supplied by a single core power supply, the sense resistor should be placed at the center of this group. If a negative sense pin is supported by the voltage regulator it should be handled in a similar way. An example of this type of implementation is shown in [Figure 10](#).

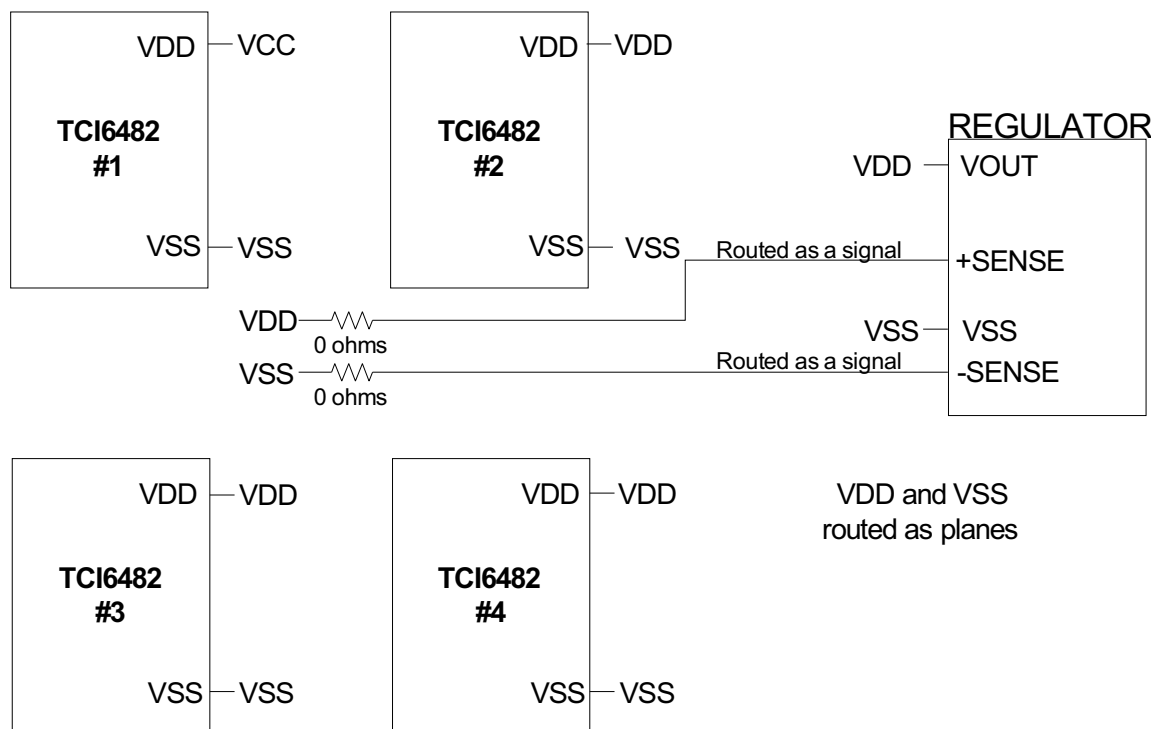

**Figure 10. Multiple DSP Remote Sense Connections**

If the connection is between one DSP and one voltage regulator, there are voltage monitor pins that can be used for this case. The monitor pins indicate the voltage on the die and therefore provide the best remote sense voltage. Early TCI6482 data manuals have these pins grouped with their respective power supplies. The voltage monitor pins are described in [Table 7](#).

**Table 7. Die Voltage Monitor Pins**

Voltage Plane	Pin Number	Description
CVDDMON	N1	Die side core voltage monitor
DVDD33MON	L6	Die side 3.3V (DVDD33) voltage monitor
DVDD18MON	A26	Die side 1.8V (DVDD18) voltage monitor
DVDD15MON	F3	Die side 1.5V or 1.8V (DVDD15) voltage monitor

These monitor pins should be connected directly to the positive side sense pin of the voltage regulator. This may not be needed if the regulator used has a low impedance path between its VOUT and +SENSE pins. Since the voltage regulator output could become unstable and drive to a high voltage if the positive sense line does not receive the correct voltage it is recommended to place a 100 ohm resistor near the DSP between the voltage plane and the monitor pin. If the VDDMON connection to the DSP is not present for some reason the positive sense will still regulate to the proper voltage. If a negative sense pin is provided by the regulator this should be connected to the GND plane near the DSP using a 0 ohm resistor. The single DSP remote sense connections are shown in [Figure 11](#).

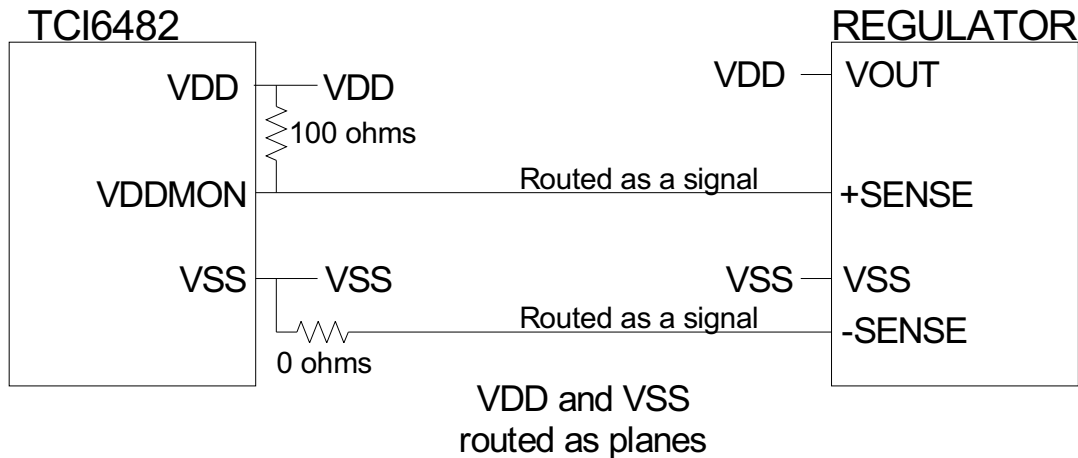

Figure 11. Single DSP Remote Sense Connections

### 7.5.2 Voltage Plane IR Drop

The voltage gradient (IR drop) needs to be considered whether or not a supply with the remote sense capability is used. The DSPs closer to the supply will have a slightly higher voltage and the DSPs farther from the supply will have a slightly lower voltage. This voltage differential can be minimized by making the copper planes thicker or by spacing the DSPs across a wider area of the plane. Be sure to consider both the core power plane(s) and the ground plane(s). The resistance of the plane can be determined by the following formula:

$$R = \rho * \text{length} / (\text{width} * \text{thickness})$$

where rho is the resistivity of copper equal to 1.72E-8 ohm-meters. PCB layer thickness is normally stated in “ounces”. One ounce of copper is about 0.012 inches or 30.5E-6 meters thick. The width must be derated to account for vias and other obstructions. A 50mm wide strip of 1oz copper plane derated 50% for vias will have a resistance of 0.57mohms per inch.

### 7.6 Power-Supply Decoupling and Bulk Capacitors

In order to properly decouple the supply planes from system noise, place as many capacitors (caps) as possible close to the DSP. Assuming 0402 caps, the user should be able to fit the number of capacitors given in [Table 9](#). These caps need to be close to the DSP, no more than 1.25 cm maximum distance to be effective. Ideally, these caps should be connected directly to the via attached to the BGA power pin. Parasitic inductance limits the effectiveness of the decoupling capacitors; therefore the physically smaller 0402 capacitors are recommended. As with selection of any component, verification of capacitor availability over the product’s production lifetime should be considered.

Proper capacitance values are also important. Small bypass caps (near **560 pF**) should be placed closest to the power pins. Medium bypass caps (**100 nF** or as large as can be obtained in a small package) should be the next closest. TI recommends placing decoupling capacitors immediately next to the BGA vias, using the “interior” BGA space and at least the corners of the “exterior”. The inductance of the via connect can eliminate the effectiveness of the capacitor so proper via connections are important. Trace length from the pad to the via should be no more than 10 mils and the width of the trace should be the same width as the pad.

Larger caps can be placed further away for bulk decoupling. Large bulk caps should be furthest away (but still as close as possible).

## 7.6.1 Selecting Bulk Capacitance

There are 2 factors that need to be considered when selecting the bulk capacitance: the effective ESR for the power plane capacitors, and the amount of capacitance needed to provide power during periods when the voltage regulator cannot respond.

The overall impedance of the core power plane is determined by:

$$(Allowable\ Voltage\ Deviation\ due\ to\ Current\ Transients) / (Max\ Current)$$

In [Section 7.5](#), it was suggested that the allowable voltage deviation allowed due to transient response is 18mV. The max transient current is estimated at 1.5A. So the impedance requirement is 18mV / 1.5Amps = 12mohms. The power plane also has some impedance. An estimate of 2mohms will require a total effective ESR of 10mohms. So the effective ESR of the bulk capacitors should not exceed this value. Multiple bulk capacitors in parallel will help achieve this overall ESR.

The amount of the bulk capacitance is determined by the amount of time that the power regulator cannot respond to the power demand and the amount of power that needs to be delivered during this time. The maximum current change measurements have been made which show:

- Max current swing: 1.5Amp

The decoupling caps provide the immediate current through the transition but the bulk capacitors need to supply this current until the voltage regulator can respond. A typical power regulator would have about a 10KHz bandwidth with a large capacitive load (needed to maintain the 18mV deviation). Assuming this bandwidth and a 1.5A current transient, the minimum bulk capacitance needed is estimated at 1500uF. So for this case the bulk capacitance needs to add up to 1500uF and create an effective ESR of 10mohms. The capacitance may need to be further increased to cover temperature derating. Examples of suitable capacitors are shown in [Table 8](#).

**Table 8. Bulk Capacitor Examples**

Manufacturer	Type	Part Number	C	Vmax	ESR	QTY
AVX	Tantalum	TPSD337K004R0035	330uF	4V	35mΩ	5
KEMET	Tantalum	T530X687M004ASE005	680uF	4V	5mΩ	3
SANYO	POS-CAP	2R5TPD1000M5	1000uF	2.5V	5mΩ	2

Capacitor selection should be done as shown above for the specific power supply implementation. If multiple TCI6482 devices are used on a single core power plane the total capacitance could be reduced per device if the expectation was that the transients would not occur on all devices simultaneously.

## 7.6.2 Recommended Capacitance

Recommended capacitor selection is given in [Table 9](#) where it is also compared with the TCI100 capacitor recommendations. The TCI6482 capacitor selection does not necessarily include power supply output capacitance. Output capacitors are provided along with the power supply reference designs.

**Table 9. Capacitor Recommendations**

TCI6482				TCI100			
Voltage Supply	Capacitors	Total Capacitance	Description	Voltage Supply	Capacitors	Total Capacitance	Description
CVDD	10 * 560pF 20 * 100nF 3 * 680uF 2 * 22uF	2084uF	1.2V Core	CVDD	1 * 330uF 32 * 100nF	333.2 uF	Core
DVDD33	16 * 560pF 24 * 100nF 1 * 330uF	330uF	3.3V I/O	DVDD	1 * 330uF 32 * 100nF	333.2 uF	I/O

**Table 9. Capacitor Recommendations (continued)**

DVDD18	8 * 560pF 12 * 100nF 2 * 330uF	661.2uF	1.8V I/O PLLs DLLs				
DVDD15	4 * 560pF 4 * 100nF 2 * 10uF	20.4uF	RGMI				
DVDD12	4 * 560pF 8 * 100nF 3 * 10uF	30.8uF	SRIO				

## 7.7 Discrete and Module Power Supply Solutions

TI can supply recommended power supply designs for discrete or module based solutions upon request.

## 7.8 Power Saving Options

### 7.8.1 Clock Gating unused Unused Peripherals

The TCI6482 can keep (or put) inactive/unused peripherals into a low power state. This capability is discussed in the TCI6482 data manual. All peripherals that are not enabled are clock gated in order to conserve power. After power-up, only those peripherals that are needed should be enabled.

Peripherals can also be disabled and put back into a lower power state. However, this should only be done if no accesses to the peripheral will occur. Once a peripheral has been disabled it cannot be re-enabled until after a reset.

### 7.8.2 Power Down Peripherals

Some peripherals that are disabled via the reset configuration can have their dedicated power planes be connected to VSS. This achieves the lowest possible power dissipation. These peripherals are:

- SRIO: All SRIO power planes (DVDDRM, DVDDR, DVDD12, AVDDA, AVDDT) connect to VSS
- RGMII: DVDD15, VREFHSTL, RSV07, RSV08, RSV13, RSV14 connected to VSS
- DDR2: VREFSSTL, RSV11, RSV12 connect to VSS

Connecting these interfaces to VSS will prohibit the use of boundary scan to test the signals on these interfaces.

For details on how to handle disabled peripherals refer to the peripheral specific chapters at the end of this document.

### 7.8.3 General Power Saving Techniques

The following are some additional methods for reducing power:

- Lower frequency operation means lower power. The core and peripherals should be operated at the lowest frequency that meets the user's requirements.
- SRIO link power does not scale linearly with data rate. So a single 3.125Gbps link consumes less power than three 1.25Gbps links. Generally, running fewer high speed links is more power efficient than multiple slower links.
- RGMII operation at 1.5V will have lower power consumption than at 1.8V.

## 8 I/O Buffers

## 8.1 PTV Compensated Buffers

The impedance of I/O buffers is affected by process, temperature and voltage. For some interfaces, these impedance changes can make it difficult to meet specifications across the full range of these parameters. For that reason, the TCI6482 uses PTV (process, temperature, voltage) compensated I/O buffers for critical interfaces. The PTV compensation works by adjusting internal impedances to nominal values based on external reference resistances. The interfaces that use PTV compensated I/O buffers and the details on the reference resistances are given in [Table 10](#).

**Table 10. PTV Compensated Interfaces**

Interface	Operating Voltage	Reference Resistance
PCI	3.3V (DVDD33)	39 ohm resistor from RSV15 to GND 20 ohm resistor from RSV16 to DVDD33
RGMII	1.5V or 1.8V (DVDD15)	200 ohm resistor from RSV13 to GND 200 ohm resistor from RSV14 to DVDD15
DDR2	1.8V (DVDD18)	200 ohm resistor from RSV11 to GND 200 ohm resistor from RSV12 to DVDD18

The resistors used can be standard 5% tolerance.

## 8.2 I/O Timings

The I/O timings in the TCI6482 data manual are given for the tester test load. These timings need to be adjusted based on the actual board topology. In general, datasheet timings for interfaces that existed on the TCI100 device have remained the same. However, some differences exist. Refer to the datasheet for details. Since the TCI6482 is a completely new device, the nominal timings may be different than the TCI100 and the I/O buffers may perform differently with a particular board topology. For these reasons, it is highly recommended that timing for all high speed interfaces (with the exception of DDR and SRIO) on a TCI6482 design be checked using IBIS simulations. For more details on performing IBIS simulations see, [Using IBIS Models for Timing Analysis \(SPRA839\)](#).

The clock for many peripherals is generated by a divide down from the CPU core clock. Since the CPU core clock is different than the TCI100, the divider and timings should be checked. This impacts the McBSP, EMIFA and Timer Peripherals.

## 8.3 External Terminators

The TCI6482 input/output (I/O) buffers have been modified for the new manufacturing process and have a different output impedance than those of the TCI100. For boards designed with the TCI100, termination resistor values should be checked by running IBIS simulations.

Series impedance is not always needed but is recommended for some interfaces to avoid over-shoot/under-shoot problems. Check the recommendations in the Peripherals chapters and/or perform IBIS simulations on the interface.

## 9 Peripheral Section

This section covers each of the TCI6482 peripherals/modules. This section is intended to be used in addition to the information provided in the TCI6482 data manual, the Module Guides provided for each of the peripherals and relevant application notes. The 4 types of documents should be used as follows:

- Data Manual: AC Timings, Register Offsets
- Module Guide: Functional Description, Programming Guide
- Applications Notes: System level issues
- This Chapter: Configuration, System level issues not covered in a separate application note, Differences to the TCI100

Each peripheral section includes recommendations on how to handle pins on interfaces that are disabled or for unused pins on interfaces that are enabled. Generally, if internal pull-ups or pull-downs are included the pins can be left floating. Any pin that is output only can always be floated. If internal pull-ups and

pull-downs are not included normally pins can still be floated with no functional issues for the device. However, this normally does cause additional leakage currents which can be eliminated if external pull-ups or pull-downs are used. When pull-ups or pull-downs are used the leakage current is approximately 100uA per pin. When the pins are floating the leakage can be several milliamps. Although the recommendations normally indicate using external pull-up resistors, pull-down resistors can also be used. The leakage is the same whether pull-ups or pull-downs are used. Connections directly to power or ground can be used only if the pins can be guaranteed to never be configured as outputs. Use of boundary scan normally drives all signals as outputs so direct connections to power or ground are not recommended if boundary scan is used.

If a peripheral is selected (via the configuration strapping) but not enabled (via the peripheral configuration register), then the I/Os can be treated the same as if the peripheral was not selected.

## 9.1 External Memory Interface (EMIFA)

Documentation for EMIFA:

- *TCI648x DSP External Memory Interface (EMIF) Reference Guide* (SPRU925)
- TCI6482 System Boot
- TCI6482 IBIS Model File
- *Using IBIS Modes for Timing Analysis* ([SPRA839](#))

### 9.1.1 Configuration of EMIFA

The EMIFA peripheral can be disabled using boot strapping options, as defined in the TCI6482 data manual. If the EMIFA is enabled via boot strapping, it still needs to be enabled via software after a reset.

The clock to be used for EMIFA can either be supplied externally to the AECLKIN pin or can be generated internally from the CPU core clock. The internally generated clock is referred to as SYSCLK4. After a reset, SYSCLK4 is CPU core clock / 8. The SYSCLK4 divider can be changed via software register accesses to PLL1.

If the EMIFA peripheral is not used, most EMIFA inputs can be left unconnected. Internal pull-up and pull-down resistors are included on this interface so leakage will be minimal. Some EMIFA signals are used for boot strapping options that are latched on the rising edge of  $\overline{\text{POR}}$  (cold boot) or rising edge of  $\overline{\text{RESET}}$  (warm boot). If these signals are connected to other components it is recommended to have 1K pull-up or pull-down resistors in order to make sure the boot strapping options are properly latched.

If only a portion of the peripheral is used, control pins that are not used should be pulled to a valid state and data pins that are not used can be left floating.

One of the boot modes is Boot over EMIF. In this mode, after reset the DSP immediately begins executing from the base address of CE3 in 8-bit asynchronous mode.

Note that all synchronous memories connected to the EMIF should have clock enable low during device power ramp and reset to avoid any inadvertent clocking of memories during power ramp and reset low. This can be done by having a weak pull-down resistor (i.e. 10K) on the CKE signals.

### 9.1.2 System Implementation of EMIFA

Generally, series resistors should be used on the EMIFA signals to reduce over-shoot and under-shoot. Generally acceptable values are 10, 22 or 33 ohms. To determine the optimum value simulations using the IBIS models should be performed to check for signal integrity and AC timings.

Significant signal degradation can occur when multiple devices are connected on the EMIFA. Simulations are the best mechanism for determining the best physical topologies and the highest frequency obtainable with that topology. Generally, a synchronous interface is best from a performance standpoint and an asynchronous interface has less performance but is easier to implement.

### 9.1.3 TCI6482 EMIFA vs TCI100 EMIFA

Table 11 shows a comparison between the EMIFA features of the TCI6482 and the TCI100. The EDMA3 FIFO addressing mode is not supported so incrementing addressing is always used. This may require not connecting lower address lines when attaching a device with a FIFO interface to the TCI6482 EMIFA interface. The AC timings for the TCI6482 are similar to TCI100 but there are some differences. Refer to the TCI6482 data manual to check AC timings.

**Table 11. EMIFA Comparison: TCI6482 vs TCI100**

	<b>TCI6482</b>	<b>TCI100</b>
Default condition (if enabled)	Disabled	Enabled
Programmable Synchronous Mode (SBSRAM, ZBT, FIFO)	ü	ü
Asynchronous Mode (ROM, SRAM)	ü	ü
Addressable Ranges	64-bit: 8MB 32/16/8-bit: 4MB	64-bit: 8MB 32-bit: 4MB 16-bit: 2MB 8-bit: 1MB
ARDY features	Can be disabled, polarity is programmable Lack of ARDY timeout supported, can generate interrupt	Always enabled and always active high Wait states can lock up the interface indefinitely
Support for late write SRAM	ü	
EMIF Boot Feature	(executes from CE3 space)	ü (1K ROM copied to L2, then executed)
SDRAM Mode		ü
PDT Transfers		ü
Clocking Options	AECLKIN, SYSCLK4 (internal divider)	AECLKIN, Core clock/4, Core clock/6
Buffer Impedance	25 Ohms (data and AECLKOUT) 50 Ohms (control)	25 Ohms

## 9.2 Host Port Interface (HPI) Memory Access

Documentation for HPI:

- *TMS320TCI648x DSP Host Port Interface (HPI) User's Guide* (SPRU874)
- TCI6482 System Boot
- TCI6482 IBIS Model File
- Using IBIS Modes for Timing Analysis ([SPRA839](#))

### 9.2.1 Configuration of HPI

The HPI interface is multiplexed with the PCI interface. Selection between HPI and PCI is done via boot strapping and latched by reset. If HPI is selected, a second boot strapping option selects the HPI bus width as either 16 bit or 32-bit. The supported Boot over HPI option is selected by boot strapping as well. Refer to the TCI6482 data manual for details on the strapping options.

Internally the HPI module is clocked by SYSCLK3, which is CPU core clock / 6. Therefore, the maximum HPI timing is somewhat dependent on the CPU core clock frequency.

If neither HPI nor PCI is used, either PCI or HPI mode can be selected by the boot strapping and the signals may be no-connects (as long as the peripheral is not enabled via the peripheral configuration register). However, there may be additional power consumption when inputs are left floating. This can be avoided by putting pull-up resistors on unused inputs.

If only a portion of the interface is used (i.e. HPI16 mode), control signals should be pulled to an appropriate state and unused data signals can be left floating, although the power consumption will be higher than if external pull-ups are used on these data signals.



### 9.2.2 System Implementation of HPI

Generally, series resistors should be used on the HPI signals to reduce over-shoot and under-shoot to reduce EMI. Generally acceptable values are 10, 22 or 33 ohms. To determine the optimum value simulations using the IBIS models should be performed to check for signal integrity and AC timings.

**Table 12. HPI Comparison: TCI6482 vs TCI100**

	<b>TCI6482</b>	<b>TCI100</b>
Default condition (if selected)	Disabled	Enabled
Supports 16 and 32-bit widths	ü	ü
Supports Boot over HPI	ü	ü
HCNTL[1:0] states	00: HPIC access 01: HPID access (auto inc) 10: HPIA access 11: HPID access (fixed address)	00: HPIC access 01: HPIA access 10: HPID access (auto inc) 11: HPID access (fixed address)
Support for SW polling of HRDY		ü
Host can reset CPU core	ü	
Emulation Free/Soft bits	ü	

## 9.3 PCI Peripheral

Documentation for PCI:

- *TMS320TCI648x DSP Peripheral Component Interconnect (PCI) User's Guide (SPRUE69)*
- TCI6482 System Boot
- TCI6482 IBIS Model File
- *Using IBIS Modes for Timing Analysis (SPRA839)*

### 9.3.1 Configuration of PCI

The PCI interface is multiplexed with the HPI interface. Selection between HPI and PCI is done via boot strapping and latched by reset.

Due to other signal multiplexing, the enabling of PCI limits the Utopia interface to single PHY mode.

If PCI is selected, a second boot strapping option allows the PCI to get auto-initialized from an I2C ROM. The PCI auto-initialization table, if used, needs to be installed at offset 0x400 in the I2C ROM. This allows Boot over I2C ROM and PCI auto-initialization to both utilize the same EEPROM.

Another PCI strapping option selects between 33MHz and 66MHz PCI. This needs to be strapped based on the PCI clock rate being used.

The Boot over PCI option is selected by boot strapping as well.

Refer to the TCI6482 data manual for details on the strapping options.

If neither HPI nor PCI is used, either PCI or HPI mode can be selected by the boot strapping and the signals may be no-connects (as long as the peripheral is not enabled via the peripheral configuration register). However, there may be additional power consumption when inputs are left floating. This can be avoided by putting pull-up resistors on unused inputs.

If the peripheral is used but some control signals are not needed, these control signals should be pulled to an appropriate state.

### 9.3.2 System Implementation of PCI

When the PCI interface is enabled the following PCI signals should have pull-up resistors: PFRAME, PTRDY, PIRDY, PDEVSEL, PSTOP, PSERR, PPERR, and PINTA. Typical resistance values are 8.2Kohms but this is dependent on the number of loads. Refer to the PCI specification for details on determining the optimal pull-up value.

Operating PCI at 66MHz has tight timing requirements and should only be implemented for point-to-point implementations.

The PCI specification gives sufficient guidelines that if followed, simulations are unnecessary. But if the PCI specification guidelines are not followed or there is something unique in the implementation, IBIS models are provided so simulations can be run.

### 9.3.3 TCI6482 PCI vs TCI100 PCI

**Table 13. PCI Comparison: TCI6482 vs TCI100**

	<b>TCI6482</b>	<b>TCI100</b>
Default condition (if selected)	Disabled	Enabled
PCI Conformance	PCI Specification Revision 2.3	PCI Specification Revision 2.2
Operating Frequency	33MHz or 66MHz	33MHz
PCI Auto-Initialization Interface	I2C ROM	McBSP to SPI ROM
Target Window (outbound transfers)	32 8MB programmable target windows mapped to DSP memory space.	1 fixed target window. Maximum of single 64MB transfer.
Target Window (inbound transfers)	6 base programmable windows unlimited access range.	3 fixed base addresses
Supports Boot over PCI	ü	ü

## 9.4 Multichannel Buffered Section Port (McBSP)

Documentation for McBSP:

- *TMS320TCI648x DSP Multichannel Buffered Serial Port (McBSP) Reference Guide (SPRU803)*
- TCI6482 IBIS Model File
- *Using IBIS Modes for Timing Analysis (SPRA839)*

### 9.4.1 Configuration of McBSP

McBSP0 and McBSP1 are multiplexed with the VLYNQ peripheral and a boot strapping option is used to select between them. Another strapping option selects between McBSP1 and GPIO pins. After a reset, software must enable the McBSP interface(s).

The McBSP module receives SYSCLK3 as its input clock, which runs at the CPU core clock / 6. The McBSP port clocks can either be driven by an external clock (CLKS) or by an internal clock which is derived from SYSCLK3. There is only one CLKS input which supplies both McBSP ports, but both ports can individually be programmed to use internal or external (CLKS) clocks.

If the internal clock is selected, the minimum divisor is /2. For example, if the core clock is 1GHz then SYSCLK3 is 166MHz and the maximum McBSP clock is 83MHz.

If a McBSP port is not used or some of the signals are not used, the pins can be left unconnected since internal pull-ups/downs are included. The CLKS also has an internal pull-down so that it may be left unconnected if not used.

### 9.4.2 System Implementation of McBSP

The maximum McBSP performance is achievable only when using source synchronous modes and point-to-point connections. In this case, series resistance should be used to reduce over/under-shoot. Generally acceptable values are 10, 22 or 33 ohms. To determine the optimum value simulations using the IBIS models should be performed to check signal integrity and AC timings.

Multiple DSPs can be connected to a common McBSP bus using TDM mode. The additional loads will require a reduction in the operating frequency. Also, the specific routing topology becomes much more significant as additional DSPs are included. The way to determine the best topology and maximum operating frequency are by performing IBIS simulations.

TI performed simulations on an 8 TCI6482 topology and the best routing topology for this is shown in Figure 12. This topology was able to operate with a 10MHz McBSP clock.

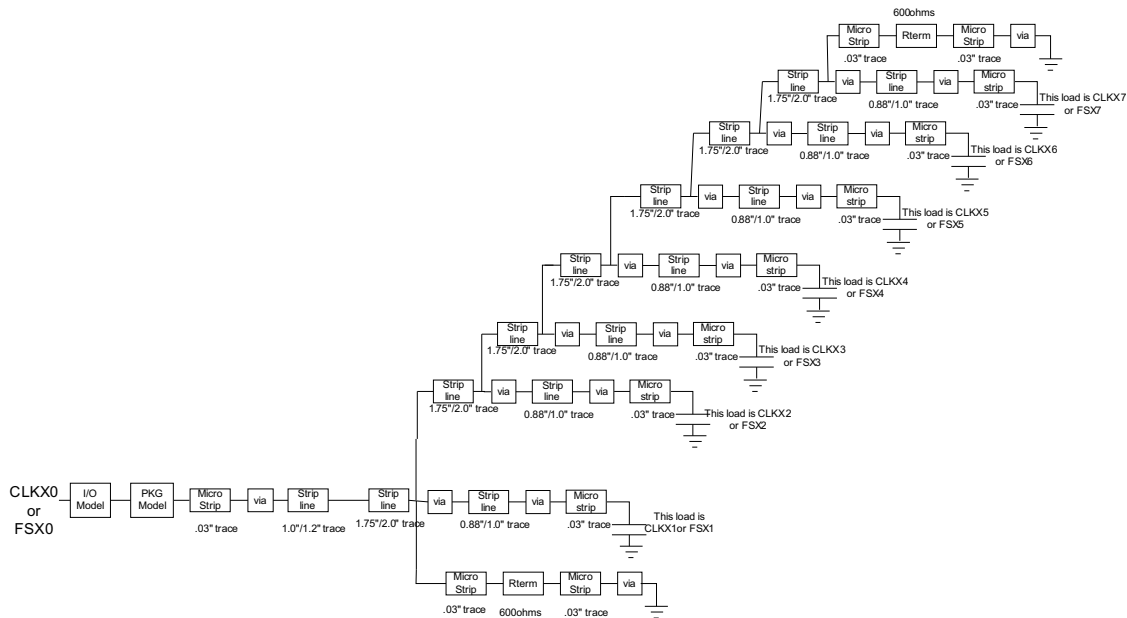

**Figure 12. McBSP 8 Load Routing Topology**

### 9.4.3 TCI6482 McBSP vs TCI100 McBSP

All the same McBSP modes are available on the TCI6482 as the TCI100. The differences between the McBSP implementations are highlighted in Table 14.

**Table 14. McBSP Comparison: TCI6482 vs TCI100**

	<b>TCI6482</b>	<b>TCI100</b>
Default condition (if selected)	Disabled	Enabled
Number of McBSP ports	2	3
CLKS per McBSP port	No, one CLKS for both ports	Yes
Minimum clock period (CLKR/X)	6 * core clock period or 10ns (whichever is greater)	6.67ns (based on internal speeds)
McBSP used for PCI auto-initialization	No, I2C is used	Yes, McBSP2 is used

## 9.5 Enhanced VCP

Documentation for VCP2:

- *TMS320TCI648x DSP Viterbi-Decoder Coprocessor (VCP) Reference Guide (SPRUE09)*

### 9.5.1 Configuration of VCP2

VCP2 needs to be enabled via software after a reset.

The VCP2 operates at CPU core clock / 3.

## 9.5.2 TCI6482 VCP2 vs TCI100 VCP

The VCP2 is backwards compatible with the TCI100 VCP and it is enhanced in terms of performance (data throughput), programmability and usability (bug fixes).

For details on migrating from VCP to VCP2, refer to the migration document listed above. For a summary of the changes refer to [Table 15](#), [Table 16](#), and [Table 17](#).

**Table 15. VCP2 Summary of Changes on TCI6482**

Feature	TCI100 VCP	TCI6482 VCP2	Impact
VCP Clock	CPU Core Clock/4	CPU Core Clock/3	Increased data rate
Branch Metric Resolution	7-bits	8-bits	Increased dynamic range
FMAXI FMAXS FMINS Y-Bit	Only valid for (R + C) % = 4	Valid for all frame lengths	Feature usable for most frame lengths
Traceback Soft Decision RAM	1024 x 96	2048 x 64-bits	Longer sliding windows in soft decision mode
Output FIFO RAM	32 x 64	64 x 64	
Soft Decision Resolution	12-bits	8-bits	
Hard Decision Ordering	Oldest bit is in the MSB	Programmable	More flexibility
Debugging Features	Pause	Pause after each sliding window	Better visibility
Emulation Control	NO	Full Emulation Control	Better visibility for System Debug
HIU/EDMA Interface	Shared HIU 64-bits	Dedicated 64-bit bridge	Reduced EDMA transfer time
RAMs Sleep Mode	NO	YES	More Power Efficient
VCP Errata	See the latest C6416 errata sheet	All critical errata corrected	Usability improvement
Chip Support Library	Available today	Backwards compatible with C6416	Reduce migration effort

**Table 16. VCP2 Usage Change on TCI6482**

Feature	TCI100 VCP	TCI6482 VCP2	Impact
Added in ¼ buffer events	½ buffer events	¼ buffer events and ½ buffer events	Flexibility
Memory Map	Yes	Yes - Modified	Coding Migration

**Table 17. VCP2 Register Changes on TCI6482**

Feature	TCI100 VCP	VCI6482 TCP2	Impact
VCPIC 3-5	Yes	Modified	Coding Migration
VCP Output Register 0-1 (VCPSTAT0)	Yes	Modified	Coding Migration
VCP Status Register 0 (VCPSTAT0)	Yes	Modified	Coding Migration
VCP error register (VCPERR)	Yes	Modified	Coding Migration
VCP Endian Register	Yes	Modified	Coding Migration
VCP Execution Register (VPCXE)	Yes	Modified	Coding Migration
Peripheral Identification Register (PID)	Yes	Modified	Coding Migration
VCP Emulation Control Register (VCPEMU)	Yes	Modified	Coding Migration

## 9.6 Enhanced TCP

Documentation for TCP2:

- *TMS320TCI648x DSP Turbo-Decoder Coprocessor (TCP) Reference Guide (SPRUE10)*

### 9.6.1 Configuration of TCP2

TCP2 needs to be enabled via software after a reset.

The TCP2 operates at CPU core clock frequency / 3.

### 9.6.2 TCI6482 TCP2 vs TCI100 TCP

TCP2 is backwards compatible with TCP and it is enhanced in terms of performance (data throughput), programmability and usability (bug fixes).

For details on migrating from TCP to TCP2, refer to the migration document listed above. For a summary of the changes refer to [Table 18](#), [Table 19](#), and [Table 20](#).

**Table 18. TCP2 Summary of Changes on TCI6482**

Feature	TCI100 TCP	VCI6482 TCP2	Impact
TCP Clock	CPU Core Clock/2	CPU Core Clock/3	Reduced decoding time
Prolong Reduction	NO	YES	
Standalone Frame Size	5114	20730	
Code Rates	½, 1/3, ¼	1/2, 1/3, ¼, ¼, 1/5	Increased Programmability
Input Formats	8-bit, depends on code rate	6-bit, always assumes 1/5	Memory efficiency
Input Sign	Not Programmable	Programmable	Offloads DSP CPU
Stopping Criterion	SNR	SNR or CRC	BER improvement Offloads DSP CPU
Re-encoding	NO	YES	Offloads DSP CPU
Log Equation	Max	Max and Max	Programmability
Interleaver Load	Before decoding	Concurrently with first MAP	Reduced latency
Hard Decision Ordering	Oldest bit is in the MSB	Programmable	Programmability
Decoding Features	Pause	Pause after each MAP, Emulation Support	Better visibility
Extrinsic Scaling	NO	YES, used in max-log-map	Better BER
HIU/EDMA Interface	Shared HIU 64-bits	Dedicated 64-bit bridge	Reduced EDMA transfer time
Memory Sleep Mode	NO	YES	Power efficient

**Table 18. TCP2 Summary of Changes on TCI6482 (continued)**

TCP Errata	See errata sheet	All critical errata corrected	Usability improvement
Chip Support Library	Available today	Backwards compatible with C6416	Reduced migration effort

**Table 19. TCP2 Usage Change on TCI6482**

Feature	TCI100 TCP	TCI6482 TCP2	Impact
Memory Map	Baseline	Modified	Coding Migration

**Table 20. TCP2 Register Changes on TCI6482**

Feature	TCI100 TCP	TCI6482 TCP2	Impact
TCPIC 0-11	YES	YES-Modified	Coding Migration
TCPIC 12-15 (Extrinsic Scaling Registers)	NO	YES	Coding Migration
TCPOUT 0	YES	YES - Modified	Coding Migration
TCPOUT 1- 2	NO	YES	Coding Migration
TCPEXE TCPEND TCPERR TCPSTAT	YES	YES - Modified	Coding Migration
Peripheral ID Register	NO	YES	Coding Migration

## 9.7 GPIO/Device Interrupts

Documentation for GPIO/Interrupts:

- *TMS320TCI648x DSP General-Purpose Input/Output (GPIO) User's Guide (SPRU725)*
- TCI6482 IBIS Model File
- *Using IBIS Modes for Timing Analysis (SPRA839)*

### 9.7.1 Configuration of GPIO/Interrupts

All GPIOs are multiplexed with other peripherals except for GP4 – GP7. The availability of the other GPIOs is dependent on which peripherals are selected by boot strapping. For details on multiplexing options and how to select GPIOs refer to the TCI6482 data manual.

All GPIOs that are selected by boot strapping, as well as GP4 – GP7, need to be enabled via software before they can be configured. All GPIOs default to inputs.

All GPIOs can be used as interrupts and/or EDMA events. The GPIO module operates at CPU core / 6.

The fastest a GPIO can be switched is at half this rate. For example, at a CPU core frequency of 1GHz the GPIO module clock is 166MHz and the max GPIO clock switching rate is 83MHz (or a max clock rate of 41.5MHz).

All GPIOs except GP2 and GP12-GP15 have internal pull-down resistors, so these can be left un-connected if not used. GP2 and GP12-GP15, if selected as GPIOs, can be left floating with a power consumption penalty versus having external pull-up or pull-down resistors.

### 9.7.2 System Implementation of GPIO/Interrupts

It is recommended that GPIO's used as outputs have a series resistance (22 or 33 ohms being typical values). The value (or need) for the series resistor can be determined by simulating with the IBIS models.

If a GPIO needs to default to a particular state (low or high), an external resistor should be used. A pull-up value of 1K is recommended to make sure that it over-rides the internal pull-down present on some GPIOs.

GP0, GP1 and GP3 have output current ratings,  $I_{OH} / I_{OL}$ , of 8mA / -8mA making them more suitable for directly driving some LEDs as opposed to all other GP pins which have 4mA / -4mA output current ratings.

### 9.7.3 TCI6482 GPIO/Interrupt vs TCI100 GPIO/Interrupt

**Table 21. GPIO/Interrupt Comparison: TCI6482 vs TCI100**

	<b>TCI6482</b>	<b>TCI100</b>
Default condition (if selected)	Disabled	Enabled
All GPIOs can generate Interrupts/EDMA Events	Yes	No, only GP0 and GP4-GP7

## 9.8 Timers

Documentation for Timers:

- *TMS320TCI648x DSP 64-Bit Timer User's Guide* (SPRU818)
- *TMS320C64x/C64x+ DSP CPU and Instruction Set Reference Guide* ([SPRU732](#))
- *Using IBIS Modes for Timing Analysis* ([SPRA839](#))

### 9.8.1 Configuration of Timers

There are 2 timer peripherals: Timer0 and Timer1. Each timer needs to be enabled via software after a reset before it can be used.

Each timer can be configured as a single 64-bit timer or as two 32-bit timers. There is an external timer input signal and an external timer output signal for each timer. When a timer is used as two 32-bit timers, the timer input and output can only be used with the lower 32-bit timer.

The timer module is clocked from CPU core clock frequency / 6. The timer input clock can be configured to use the external timer input signal, the internal timer module clock (CPU core clock / 6) or as a gated internal clock where the external timer input signal is used to gate the internal timer module clock.

If the external timer signals are not used, the pins can be left unconnected and the internal pull-downs will bring the input to a low state.

In addition to the timer peripherals the CPU has a 64-bit free running counter that advances each CPU clock after counting is enabled. The counter is accessed using two 32-bit read-only control registers in the CPU. For more details on this timer, refer to the Time Stamp Counter Registers described in the TMS320C64x/C64x+ DSP CPU and Instruction Set Reference Guide.

### 9.8.2 System Implementation of Timers

It is recommended that external timer signals use series resistance (22 or 33 ohms being typical values). The value (or need) for the series resistor can be determined by simulating with the IBIS models.

External timer input signals are synchronized to the internal timer clock. Since the timer operates at CPU core / 6, the timer input can be delayed from the timer input as much as one CPU core / 6 period.

### 9.8.3 TCI6482 Timers vs TCI100 Timers

**Table 22. Timer Comparison: TCI6482 vs TCI100**

	<b>TCI6482</b>	<b>TCI100</b>
Default condition (if selected)	Disabled	Enabled
Number of Timer modules	2	3
Timer size (each)	1 @ 64-bits, 2@ 32-bits	32 bits
Watchdog functionality	Yes	No
Internal Timer clock frequency	CPU core clock / 6	CPU core clock / 8
64 bit free running CPU counter	Yes	No

## 9.9 EDMA3

Documentation for EDMA3:

- *EDMA v3.0 (EDMA3) Migration Guide for TMS320TCI648x DSP* ([SPRAAC1](#))
- *TMS320TCI648x DSP Enhanced DMA (EDMA3) Controller User's Guide* ([SPRU727](#))

### 9.9.1 Configuration of EDMA3

The EDMA is enabled after a reset.

The EDMA is clocked at CPU core clock / 3.

### 9.9.2 System Implementation

Configuration across the EDMA may not take affect immediately. In order to make sure that a peripheral configuration has completed before accessing that peripheral it is recommended to setup an interrupt to occur after the DMA has completed. After the interrupt is asserted the peripheral can be accessed.

### 9.9.3 TCI6482 EDMA3 vs TCI100 EDMA

The FIFO addressing mode of the EDMA3 channel controller is not supported by any of the peripherals on the TCI6482 device, therefore, increment addressing mode should always be used. The migration document referenced above gives a complete overview of the differences between the TCI6482 and the TCI100 EDMA implementations.

## 9.10 Inter-Integrated Circuit (I<sup>2</sup>C)

Documentation for I<sup>2</sup>C:

- *TMS320TCI648x DSP Inter-Integrated Circuit (I2C) Module User's Guide* (SPRUE11)
- TCI6482 System Boot
- TCI6482 IBIS Model File
- *Using IBIS Modes for Timing Analysis* ([SPRA839](#))
- Philip's I2C Version 2.1 Specification:  
[http://www.semiconductors.philips.com/acrobat\\_download/literature/9398/39340011.pdf](http://www.semiconductors.philips.com/acrobat_download/literature/9398/39340011.pdf)

### 9.10.1 Configuration of I<sup>2</sup>C

The I<sup>2</sup>C peripheral needs to be enabled via software before use. The input clock for the I<sup>2</sup>C module is core clock / 6. There is a prescaler in the I<sup>2</sup>C module that needs to be setup to reduce this frequency to an internal module clock of 7 to 12MHz.

If the I<sup>2</sup>C signals are not used, the SDA and SCL pins can be left floating. This does cause a slight increase in power due to leakage which can be avoided by having pull-up resistors.



## 9.10.2 System Implementation of I<sup>2</sup>C

External pull-up resistors to 3.3V are needed on the I<sup>2</sup>C signals (SCL, SDA). The recommended pull-up value is 4.7K ohms.

Multiple I<sup>2</sup>C devices can be connected to the interface but the speed may need to be reduced (400KHz is the maximum) if many devices are connected.

## 9.11 Ethernet Media Access Controller

Documentation for Ethernet Media Access Controller (EMAC):

- *TMS320TCI648x DSP EMAC/MDIO Module Reference Guide* (SPRUE12)
- TCI6482 System Boot
- TCI6482 IBIS Model File
- *Using IBIS Modes for Timing Analysis* ([SPRA839](#))

### 9.11.1 Configuration of EMAC, MII, and MDIO

The EMAC interface MII/RMII/GMII signals are multiplexed with the Utopia interface, so only RGMII is available if the Utopia interface is also used. When EMAC is enabled, the MDIO interface is always enabled. Two other strapping bits are used to select the MII mode (MII, GMII, RMII, RGMII). The MII, GMII and RMII share interface pins. The RGMII uses HSTL buffers and therefore has its own interface. There are 2 sets of MDIO interfaces (LVCMOS and HSTL). If MII, GMII or RMII are selected the LVCMOS MDIO interface (MDCLK, MDIO) is used. If RGMII is selected the HSTL MDIO interface (RGMDCLK, RGMDIO) is used.

Even if EMAC is enabled by boot strapping, it still must be enabled via software before it can be accessed.

The EMAC RMII, GMII, and RGMII require specific clock frequencies from PLL2 and therefore require that CLKIN2 be 25MHz. In silicon version 2.0 and beyond RMII will no longer use the PLL2 output. MII mode does not use the PLL2 output.

The RGMII interface HSTL buffers can either be operated at 1.5V or 1.8V. This is done by powering the DVDD15 at either 1.5V or 1.8V. Operation at either of these voltages uses the same AC timings. 1.8V operation consumes slightly more power than 1.5V but eliminates the need for creation of a separate 1.5V supply. VREFHSTL is generated using a resistor divider from DVDD15 and therefore scales correctly.

In RGMII mode, the MDIO signals run at the same HSTL voltage as the RGMII signals.

For LVCMOS EMAC signals that are not used, these can either be left floating or pulled high. If left floating some additional power is drawn due to leakage through the I/O buffers. If RGMII is not used, the RGMII specific power planes should be connected to GND:

- VREFHSTL, DVDD15, RSV07, RSV08, RSV14. If RGMII power planes are connected to GND all RGMII signals (including RGMDIO and RGMDCLK) should be no-connects.  
CLKIN2 should not be left floating and should be pulled to GND if not needed.

### 9.11.2 System Implementation of MII

For termination, follow the switch/ PHY recommendations. If none are provided, it is recommended to use series resistance termination. Typical values of 22 ohms or 33 ohms are normally adequate but IBIS simulations can be used to verify the best value with a specific board implementation. All MII connections should be point-to-point only.

#### 9.11.2.1 RMII Implementation

In silicon version 1.1 the RMII interface supplies the 50MHz RMII reference clock as an output. This needs to be connected to the reference clock input of the connected RMII device. There is no guaranteed timing relationship between the CLKIN2 25MHz clock and this RMII reference clock. Therefore it cannot be assumed that aligning CLKIN2 to multiple TCI6482 devices results in aligned RMII interfaces.

In silicon version 2.0, the RMI reference clock is an input. An external clock source should provide an aligned reference clock to the TCI6482 RMI reference clock input and to the RMI device connected to the other side of the interface.

Refer to the latest TCI6482 errata sheet for details.

### 9.11.2.2 RGMII Implementation

The RGMII interface is compliant with the RGMII version 2.0 specification found at the following link:  
[http://www.hp.com/rnd/pdfs/RGMIIv2\\_0\\_final\\_hp.pdf](http://www.hp.com/rnd/pdfs/RGMIIv2_0_final_hp.pdf)

The electrical signaling is compatible to JEDEC specification JESD8-6:  
<http://www.jedec.org/download/search/jesd8-6.pdf>

Although the JEDEC specification specifically details 1.5V HSTL signaling, the TCI6482 and most other RGMII v2.0 devices support operation at 1.8V. Some devices support RGMII v1.3 (LVCMOS levels) but not RGMII v2.0 levels. An application note on how to do voltage translation from the TCI6482 1.5V/1.8V interface to an LVCMOS 2.5V/3.3V interface that operates at Gigabit speeds (125MHz) is given in the [Appendix A](#).

The RGMII interface operates at 125MHz and clocks data on both edges of the clocks. This connection should be routed with high speed interface routing rules. The RGMII specification provides timing information at both the receiver and the transmitter. The user must verify that the timing variations due to board topology are not more than allowed by the RGMII specification. TCI6482 HSTL IBIS models are provided to aid in this analysis.

The TCI6482 implements an internal delay (referred to as RGMII-ID in the RGMII specification) on the transmit signals but not on the receive signals. So the connected device should use normal mode on the transmit side (no delay) and internal delay mode on the receive side. If the connected device does not support internal delay on the receive side, the proper delay needs to be created at the board level by routing the RXC signal longer than the receive data signals. The RGMII specification calls for this trace delay to be between 1.5nS and 2.0nS. Assuming a trace flight time of 170pS/inch, the clock should be routed about 10.3 inches longer than the data and control. Flight time is dependent on board stackup and this length should be adjusted for the flight time of the specific board design.

The TCI6482 silicon version 1.1 RGMII implementation relies on the in-band signaling as defined in section 3.4.1 of the RGMII v2.0 specification in order to get link status, link speed and duplex information. Until link status "UP" is indicated on this in-band signaling the TCI6482 will not transmit. It is therefore required that the connected device support the transmission of all the in-band signaling and that this feature is enabled before attempting to use the RGMII interface. Silicon version 2.0 offers a feature to force the internal state of: link status, link speed, and duplex so that the in-band signaling will not be required.

Some RGMII v2.0 devices have the MDIO interface implemented as 2.5V/3.3V LVCMOS. If RGMII is selected on the TCI6482 only the HSTL MDIO interface is active. The circuit shown in [Figure 13](#) has been tested for this purpose. For more information and additional voltage translation options refer to the following application note: *Selecting the Right Level Translation Solution* ([SCEA035](#))

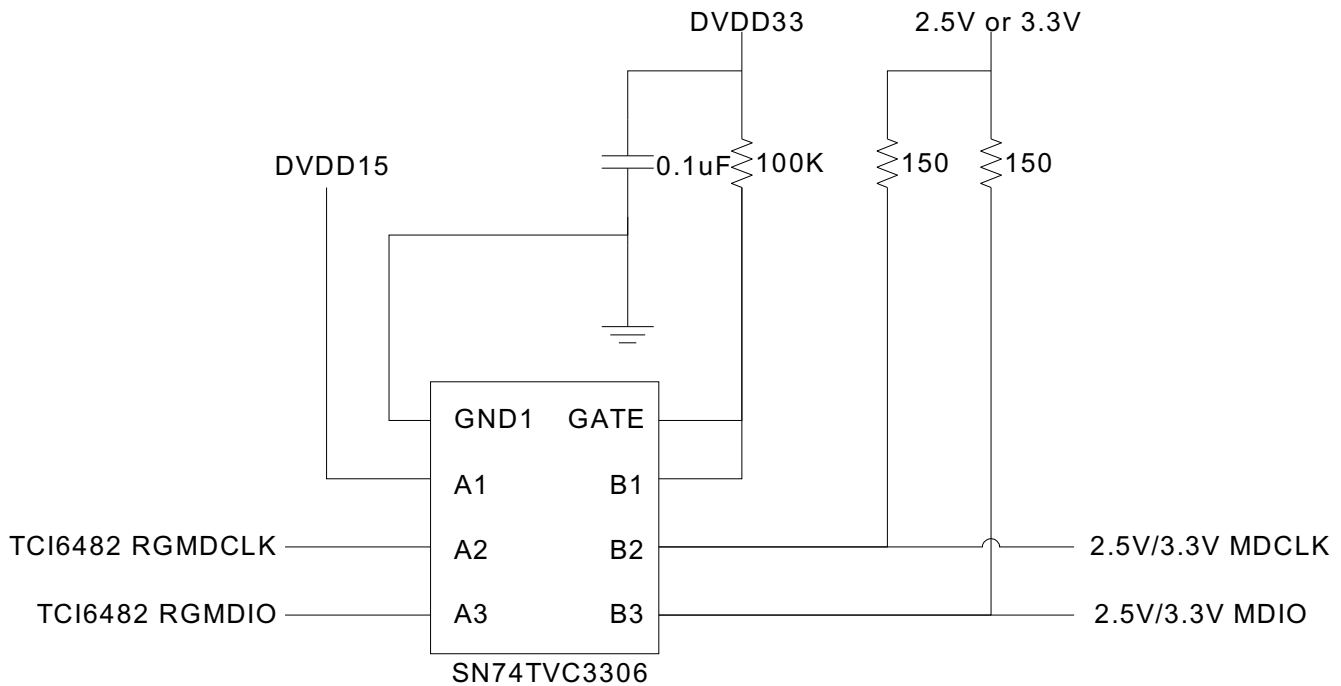

**Figure 13. HSTL to LVCMOS Translation**

## 9.12 UTOPIA

Documentation for UTOPIA:

- *TMS320TCI648x DSP Universal Test & Operations PHY Interface for ATM 2 (UTOPIA2)* (SPRU726)
- TCI6482 System Boot
- TCI6482 IBIS Model File
- *Using IBIS Modes for Timing Analysis* ([SPRA839](#))

### 9.12.1 Configuration of UTOPIA

The Utopia interface is multiplexed with EMAC MII interfaces (except RGMII). So if Utopia is enabled, only the RGMII interface is available for EMAC. Some Utopia address lines are multiplexed with PCI signals. If PCI and Utopia are both enabled Utopia will operate in single PHY mode only. Boot strapping options are used to select the state of the Utopia, EMAC and PCI interfaces. Refer to the TCI6482 data manual for more details.

The Utopia RX and TX clocks are supplied externally and supports clock rates up to 50MHz.

If the Utopia interface is selected, software needs to enable it after reset release before it is accessible.

If the Utopia interface is not enabled, the input pins can be unconnected (floating) but this will result in some additional power due to leakage. This power can be minimized by adding external pull-ups.

If the Utopia interface is enabled but some inputs are not used, external pull-ups or pull-downs are needed to put these inputs into valid states.

### 9.12.2 System Implementation of Utopia

The Utopia interface can support multiple devices on the same bus using multi-PHY mode.

The 50MHz operation should not be an issue in a point-to-point connection. However, if multiple devices are loaded on the bus, operation at 50MHz may not be possible. It is recommended to run IBIS simulations to check the signal integrity and maximum operating frequency for a particular board topology.

### 9.12.3 TCI6482 Utopia vs TCI100 Utopia

The same Utopia module is in the TCI6482 as the TCI100. There should be no differences in the implementations other than the method for configuring the peripheral.

## 9.13 VLYNQ

Documentation for VLYNQ:

- TCI6482 IBIS Model File
- *Using IBIS Modes for Timing Analysis* ([SPRA839](#))

### 9.13.1 Configuration of VLYNQ

The VLYNQ interface is multiplexed with both McBSP ports and some GPIO pins. It is selected on power-up using the boot strap options. If it is selected, software must enable the interface after a reset.

The VLYNQ module logic operates off an internal clock of CPU core clock / 6. For the interface clock, VLYNQ can be configured to use the VCLK pin as an input (external clock mode) or it can use internal clock mode and the VCLK pin becomes an output. The internal clock mode operates from SYSCLK4 which is CPU core clock / 8 by default. This clock is programmable via PLL1. SYSCLK4 is used by both VLYNQ and EMIFA so changing the divider will affect both of these interfaces. The maximum VLYNQ operating frequency (both for internal and external clock modes) is 125MHz.

If the VLYNQ peripheral is not used or some of the signals are not used, the unused VLYNQ pins can be left unconnected. Internal pull-ups/pull-downs will pull the pins to a static level.

### 9.13.2 System Implementation

VLYNQ is used in point-to-point connections only but it can be setup as a daisy chain between multiple devices. For the TXD signals series resistance should be used to reduce over/under-shoot. Generally acceptable values are 10, 22 or 33 ohms. All TXD terminals of a VLYNQ™ device connected to RXD terminals of another VLYNQ device must have equal length point-to-point signal traces without stubs.

If VCLK is used as an output a series termination is required since this is also used as the VCLK input. The series termination should be between 22 and 50 ohms. To determine the optimum series resistance values simulations using the IBIS models should be performed to check signal integrity and AC timings.

For the VCLK routing, the circuit board should be designed using point-to-point connections without stubs and enough bandwidth to support the maximum clock rate. If the VLYNQ clock rate is reduced by changing the value of the “clkdiv” bits in the VLYNQ Control Register, the circuit board must be designed to support half the maximum clock rate. This is necessary because the VLYNQ clock is only high for one cycle of the pre-divided VLYNQ clock for all clkdiv values except zero. [Figure 14](#) below shows an example where the pre-divided VLYNQ clock rate is 125 MHz and the “clkdiv” bits are set to 100 binary. In this example the VLYNQ clock rate is 25 MHz (high for 8 ns and low for 32 ns). However, the 8 ns high pulse width requires the circuit board to be designed for 62.5 MHz.

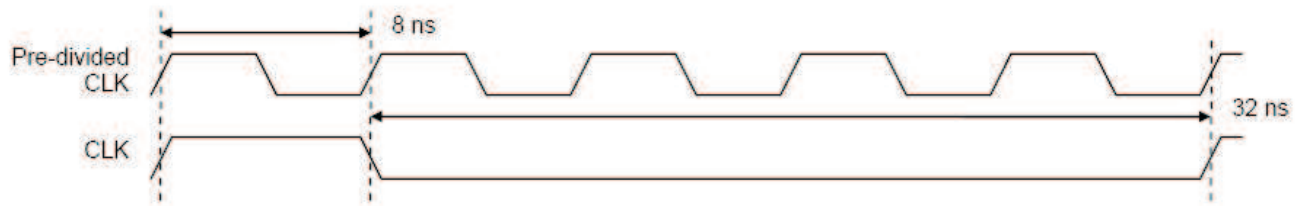

**Figure 14. VLYNQ Clock Divider Example**

If the VLYNQ clock is provided by an external source, the circuit board must be designed so transmission line reflections do not generate glitches or invalid transitions of the VLYNQ clock. In most applications, the external clock source should be connected to the CLK terminal of each VLYNQ device with two equal lengths of etch. This configuration may require series termination resistors near the source of each clock driver trace to prevent signal distortion. It may be possible to optimize timing on the VLYNQ interface by allowing one VLYNQ device to receive the VLYNQ clock before the interconnected VLYNQ device. Refer to [Section 4](#) for more details related to VLYNQ timing. However, series termination may not be the best method for terminating some configurations used to interconnect the external clock source to the two VLYNQ devices.

The width of VLYNQ is adjustable down to 1 bit wide for a 3 signal interface (clock, tx data bit, rx data bit) and has a max width of 4 bits.

## 9.14 Serial Rapid I/O (SRIO)

Relevant documentation for SRIO:

- *TMS320TCI648x DSP Serial Rapid I/O User's Guide (SPRUE13)*
- *Implementing Serial Rapid IO PCB Layout on a TMS320TCI6482 Hardware Design (SPRAAB0)*
- TCI6482 System Boot
- TCI6482 SRIO/DDR Example Schematics

### 9.14.1 Configuration of SRIO

Since the SRIO port is not multiplexed with other peripherals, there is no boot strapping option to enable/disable the SRIO port. SRIO, as with all peripherals, defaults disabled and must be enabled by software before use.

There are 4 SRIO lanes. These can be configured for operation as a single 4x link or as 4 separate 1x links.

SRIO requires a dedicated differential reference clock: RIOCLK,  $\overline{\text{RIOCLK}}$ . Recommended frequencies for this clock are 125MHz and 156.25MHz. The SERDES (serializer/deserializer) used in the SRIO solution has a PLL which needs to be configured based on this reference clock and the desired link rate. Link rates can be full, half or quarter rate relative to the PLL frequency. Refer to [Table 23](#) for PLL multiplier settings relative to link rate.

**Table 23. SRIO PLL Multiplier Settings**

Reference Clock	PLL Multiplier	Full Rate	Half Rate	Quarter Rate
125MHz	12.5	3.125Gbps	not used	not used
125MHz	10	2.5Gbps	1.25Gbps	not used
156.25MHz	10	3.125Gbps	not used	not used
156.25MHz	8	2.5Gbps	1.25Gbps	not used

It is possible to configure the TCI6482 to boot load application code over the SRIIO interface. Boot over SRIIO is a feature that is selected using boot strapping options. For details on boot strapping options refer to the TCI6482 data manual.

If the SRIIO peripheral is not used the SRIIO reference clock inputs and SRIIO link pins can be left floating. SRIIO power planes can be connected to GND in order to reduce power. These power planes are:

- DVDDRM, DVDDR, DVDD12, AVDDA, AVDDT

If the SRIIO peripheral is enabled but not all links are used, the pins of unused links can be left floating and no terminations are needed.

### 9.14.2 System Implementation of SRIIO

Refer to the *Implementing Serial Rapid IO PCB Layout on a TMS320TCI6482 Hardware Design* ([SPRAAB0](#)) for information regarding supported topologies and layout guidelines.

Suggestions on SRIIO reference clocking solutions can be found in [Section 6.3.3](#).

SRIIO power planes and power filtering requirements are covered in [Section 7.1](#).

## 9.15 DDR2

Relevant documentation for DDR2:

- *TMS320TCI648x DSP DDR2 Memory Controller User's Guide* (SPRU894)
- *Implementing DDR2 PCB Layout on the TMS320TCI6482* ([SPRAAA9](#))
- TCI6482 SRIIO/DDR Example schematics
- JEDEC JESD79-2A: <http://www.jedec.org/download/search/JESD79-2A.pdf>

### 9.15.1 Configuration of DDR2

The DDR2 peripheral is enabled/disabled using boot strapping, as defined in the TCI6482 data manual. If it is enabled, it still needs to be enabled via software after a reset.

The DDR2 clock is derived from PLL2, which uses the CLKIN2 reference clock. The DDR2 clock is 10x the CLKIN2 frequency (25MHz CLKIN2 runs the DDR clock at 250MHz). The CLKIN2 range supports a range of DDR2 operating frequencies, up to 533MHz (CLKIN2 = 26.7MHz). PLL2 is used for some of the EMAC MII modes, specifically RMII, GMII, and RGMII. When these MII modes are selected CLKIN2 must be 25MHz.

If the DDR2 peripheral is disabled all interface signals can be left floating since the input buffers are disabled when the peripheral is disabled. CLKIN2 should have an external pull-down if not used. Note that the DDR PLL voltages AVDLL1 and AVDLL2 are required to be at 1.8V even if DDR is not needed but the filter circuit can be omitted.

If the DDR2 is operated in 16 bit mode, the upper DDR2 bi-directional pins should be pulled to valid states. DSDDQS2, DSDDQS3, and DED[31:16] should have pull-up resistors to DVDD18. DSDDQS2z and DSDDQS3z should have pull-downs to GND.

### 9.15.2 System Implementation of DDR2

Refer to the *Implementing DDR2 PCB Layout on the TMS320TCI6482* ([SPRAAA9](#)) for information regarding supported topologies and layout guidelines.

Suggestions on CLKIN2 reference clocking solutions can be found in [Section 6.3.2](#).

DDR power planes and power filtering requirements are covered in [Section 7.1](#).

## 9.16 JTAG/Emulation

Relevant documentation for JTAG/Emulation:

- *60-Pin Emulation Header Technical Reference*, ([SPRU655](#))
- TMS320TCI6482 BSDL file

### 9.16.1 Configuration of JTAG/Emulation

The JTAG interface can be used for boundary scan and emulation. The boundary scan implementation is compliant to both IEEE 1149.1 and 1149.6 (for Serial RapidIO ports). Boundary scan can be used regardless of the device configuration.

As an emulation interface, the JTAG port can be used in various modes:

- Standard emulation: requires only 5 standard JTAG signals
- HS-RTDX emulation: requires 5 standard JTAG signals plus EMU0 and EMU1. EMU0 and EMU1 are bidirectional in this mode.
- Trace port: the trace port allows real-time dumping of certain internal data. The trace port uses the EMU18:0 pins to output the trace data, however the number of pins used is configurable.

Emulation can be used regardless of the device configuration.

For supported JTAG clocking rates (TCLK) refer to the TCI6482 data manual. The EMU18:0 signals can operate up to 166Mbps, depending on the quality of the board level implementation.

Any unused emulation port signals can be left floating.

### 9.16.2 System Implementation of JTAG / Emulation

For most system level implementation details, refer to the Emulation Header Technical Reference document.

For a single DSP connection where the trace feature will not be used a non-buffered implementation can be used if the connections are made per the SPRU655 application note. If the trace will be used, the JTAG signals should be buffered and TCLK and RTCLK should be buffered separately.

If multiple DSPs are included on the board and a chained JTAG interface is desired, the suggested implementation is to use a single 60 pin header with the following connections:

- Buffer and daisy chain the TDI and TDO
- Buffer and connect TCLK, TMS and TRST to all DSPs. RTCLK should be buffered separately from TCLK.
- Connect EMU0 and EMU1 to all DSPs (do not buffer)
- Connect EMU18:2 to one of the DSPs (the one which will be traced)

No external pull-ups/downs are needed since there are internal pull-ups/downs on all emulation signals.

The June 2004 version of the 60-Pin Emulation Header Technical Reference document indicates that there should be a 100K ohm resistor between the TVD pin and the devices JTAG I/O voltage. This value results in a significant voltage drop with some emulators, so the resistor should be 1K ohm instead.

It is not recommended to add both a 60-pin header and a 14-pin header due to signal integrity concerns. 60-pin to 14-pin adapters are available to allow connection to emulators that only support the 14-pin connector.

### 9.16.3 TCI6482 JTAG/Emulation vs TCI100 JTAG/Emulation

**Table 24. JTAG/Emulation Comparison: TCI6482 vs TCI100**

	TCI6482	TCI100
TRST is fully asynchronous	Yes	No
Advanced Emulation pins	19	2
Trace support	Yes	No

## 9.17 Rake Search Accelerator (RSA)

Both RSAs can be enabled by software after a reset. The RSAs operate at CPU core clock speed.

## Appendix A TCI6482 RGMII 1.5V/1.8V to 2.5V/3.3V Translation

The TCI6482 includes a variable voltage Reduced Gigabit Media Independent Interface (RGMII) for connection to a gigabit-capable Ethernet switch or PHY. The TCI6482 interface may be configured to run at either 1.5V or 1.8V I/O; controlled directly by the voltage applied to the DVDD15 pins of the device (see device data manual). These rails are compliant with the RGMII specification; however, in practice it has been found that in many cases a level translation is required between industries offering for Ethernet switch connections, which are slightly slower in migration to these lower voltage nodes.

Voltage translation of the RGMII interface is a somewhat complicated task, insomuch as the interface must be level-translated but still support dual-data rates at up to 125MHz operation. This can be very difficult to achieve using standard LVCMOS-type buffers for two reasons. Firstly, such buffers often add up to 4ns propagation delay to the buffered signals, making timing margins exceptionally small at the 125MHz rate. Secondly, such buffers often provide little to no guarantee of relative propagation delays across buffers in the same device and further specify all timings with only a single output switching, which is not realistic in a gigabit Ethernet application.

As an alternative to the LVCMOS type buffers, a good solution can be found using TVC-type buffers or CBT buffers in a TVC configuration. Texas Instruments has an excellent application note describing the configuration ([SCEA035A](#)). An example of this application is shown in [Figure A-1](#) using a CBT3245 in a TVC voltage-clamp configuration. The CBT3245 is an 8 in/out buffer, making it a nice fit for the 6 lines requiring translation in a single direction of a gigabit Ethernet application. Using this solution, two CBT3245s can be used (one for transmit, one for receive) to complete the translation.

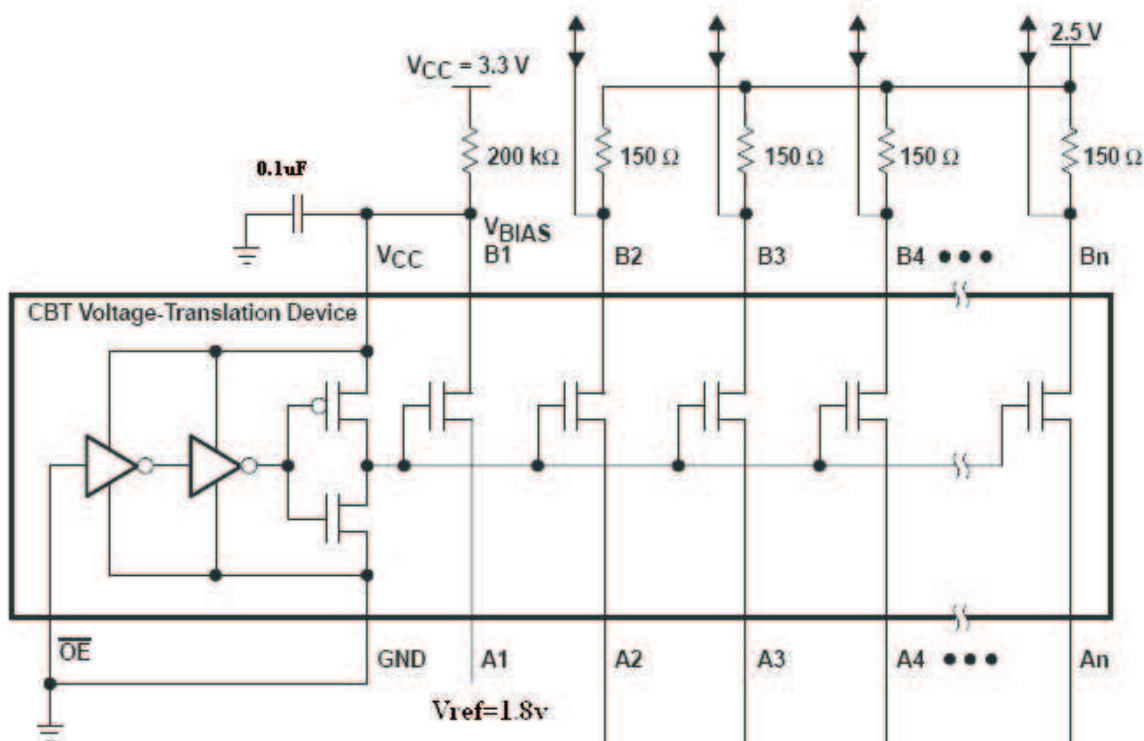

Figure A-1. RGMII Voltage Level Translation Circuit



The CBT and TVC families of buffers are excellent in this application. Both are simple FET switches, which offer sub-ns propagation delays. Because each FET switch is independent; the relative delays are matched very closely because process variations affect all switches equally. Unlike LVCMOS buffers however, these switches offer no additional current drive, however since gigabit Ethernet connections are simple point-point connections this is not a concern.

As a FET switch, the circuit in either the TVC or CBT application is the same. A single in/out pair is chosen to set the voltage clamp voltage to 1.8V on the TCI6482 side (1.5V could also be used if that voltage is used for the TCI6482 RGMII interface). Because all the gates of the CBT/TVC in/out pairs are connected, this sets the clamp voltage for all the other pairs of ins/outs because VGS for the FET is fixed. Note that the buffer itself is powered using a 3.3V supply however. This is necessary to establish a voltage at least 1V greater than the low-side clamp voltage ( $1.8V + 1V = 2.8V$  in this case).

The configuration shown above is technically a bidirectional solution; though gigabit Ethernet by its definition is unidirectional. When driving from the TCI6482 to the switch/PHY, signals will vary from 0V to 1.5V/1.8V. At the low (0V) voltage level, the FET is turned on and both sides of the buffer thus see a low level. When a 1.5V/1.8V logic high is applied, the FET is turned off because this voltage matches (nearly) the voltage applied to the gate. In this case, the pullups on the high voltage side (switch/PHY side) of the buffer pull the output to the high-side rail. Thus, in both cases the logic levels on both sides of the buffer match to their respective rails. The application circuit shown above is shown for the TCI6482's transmit direction; that is; from the TIC6482 to the switch. In the receive direction, the application circuit is the same except that the pullups to the 2.5V side of the buffer, the switch/PHY side that is, are not needed and should be omitted. In this case, pullups to 1.5V/1.8V are not required, as the buffer will act as a clamp and hold the output voltage to the 1.5V/1.8V level, thus providing the translation directly.

The values for the pullups on the high-voltage side of the CBT/TVC buffer are important. The basic trade-off that needs to be made is finding a value that is strong enough to pull to the high-side rail quickly to produce a good low-high edge rate (recall this is when the FET turns off), but is not too strong so as to not allow the low side to pull the output to a level below the VIL specification of the switch/PHY device when a low is driven (and the FET is on). In practice, a 150 Ohm pullup is a good solution.

Shown below are several SPICE plots showing the characteristics of this solution. [Figure A-2](#) shows the relationship between VIN and VOUT that establishes the clamping to the low voltage side rail even when the input voltage exceeds that rail. [Figure A-3](#) shows a square wave driven from each side and the resulting outputs. Note in all cases the extremely low propagation delay and good edge rates that result with this solution.

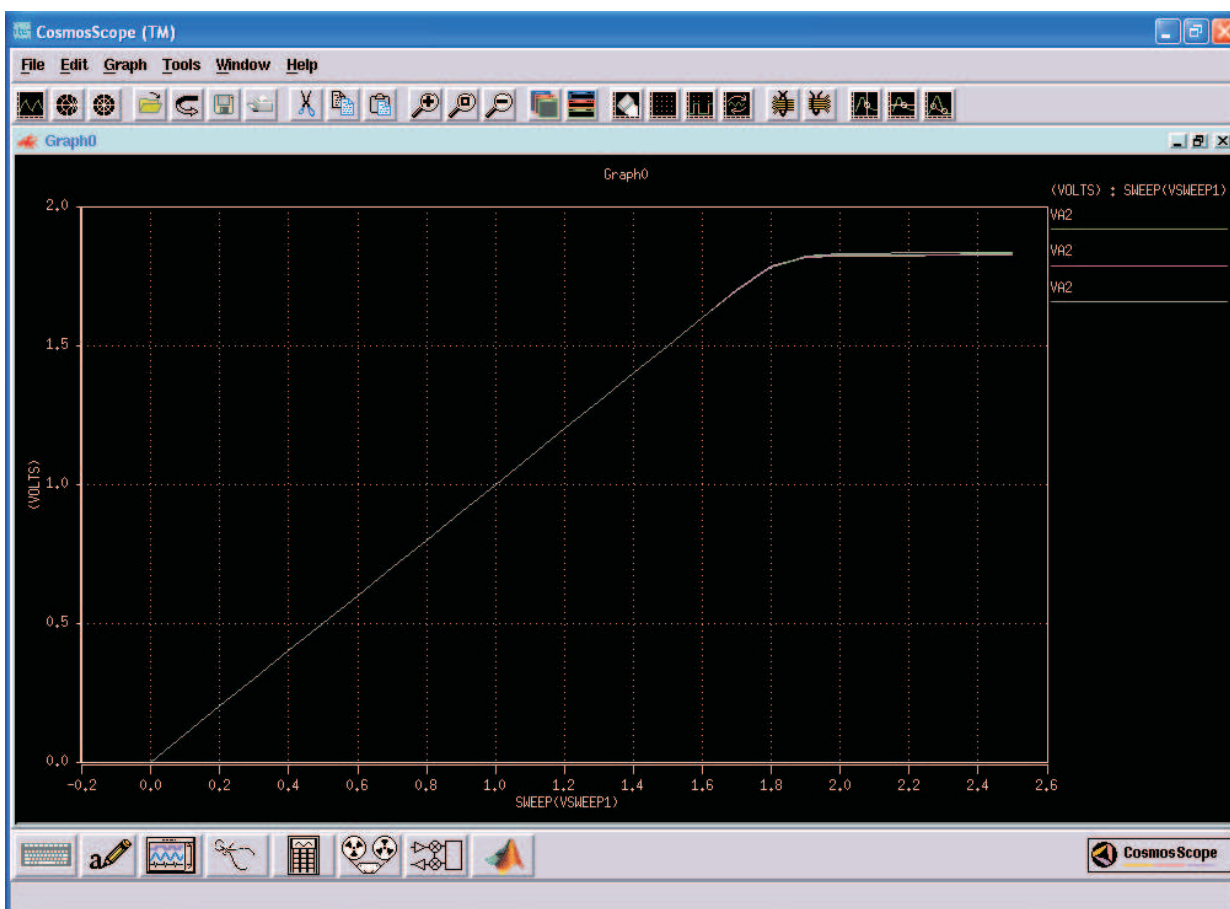

**Figure A-2. VOUT vs VIN**

**Setup for  $V_{OUT}$  vs.  $V_{IN}$  plot:** B2 was swept from 0 to 2.5v in 0.1v steps and the waveform at A2 was observed. A 1Meg resistor to GND was connected at A2.

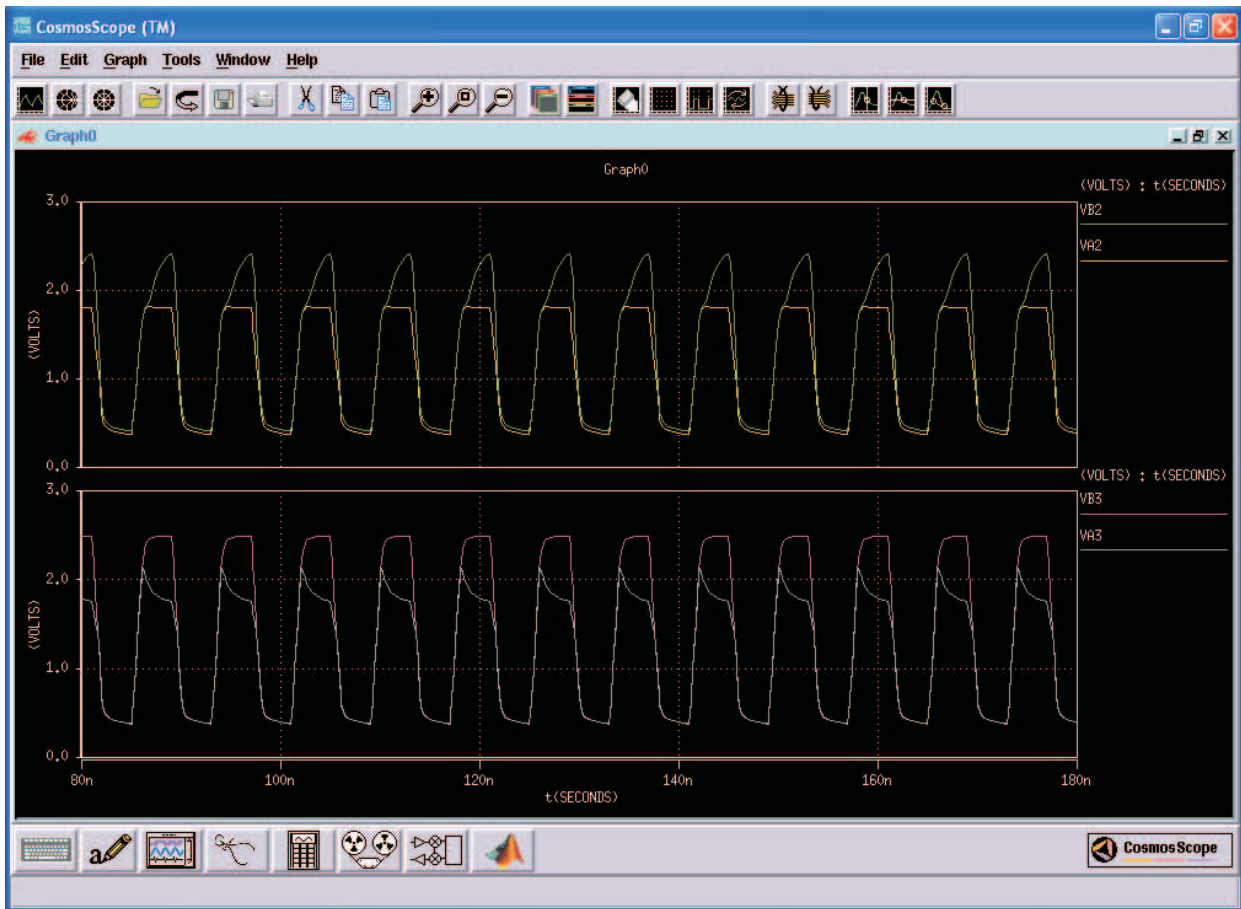

Figure A-3. 125MHz Signal from A2 to B2 and From B3 to A3

## IMPORTANT NOTICE

Texas Instruments Incorporated and its subsidiaries (TI) reserve the right to make corrections, modifications, enhancements, improvements, and other changes to its products and services at any time and to discontinue any product or service without notice. Customers should obtain the latest relevant information before placing orders and should verify that such information is current and complete. All products are sold subject to TI's terms and conditions of sale supplied at the time of order acknowledgment.

TI warrants performance of its hardware products to the specifications applicable at the time of sale in accordance with TI's standard warranty. Testing and other quality control techniques are used to the extent TI deems necessary to support this warranty. Except where mandated by government requirements, testing of all parameters of each product is not necessarily performed.

TI assumes no liability for applications assistance or customer product design. Customers are responsible for their products and applications using TI components. To minimize the risks associated with customer products and applications, customers should provide adequate design and operating safeguards.

TI does not warrant or represent that any license, either express or implied, is granted under any TI patent right, copyright, mask work right, or other TI intellectual property right relating to any combination, machine, or process in which TI products or services are used. Information published by TI regarding third-party products or services does not constitute a license from TI to use such products or services or a warranty or endorsement thereof. Use of such information may require a license from a third party under the patents or other intellectual property of the third party, or a license from TI under the patents or other intellectual property of TI.

Reproduction of information in TI data books or data sheets is permissible only if reproduction is without alteration and is accompanied by all associated warranties, conditions, limitations, and notices. Reproduction of this information with alteration is an unfair and deceptive business practice. TI is not responsible or liable for such altered documentation.

Resale of TI products or services with statements different from or beyond the parameters stated by TI for that product or service voids all express and any implied warranties for the associated TI product or service and is an unfair and deceptive business practice. TI is not responsible or liable for any such statements.

Following are URLs where you can obtain information on other Texas Instruments products and application solutions:

<b>Products</b>		<b>Applications</b>	
Amplifiers	<a href="http://amplifier.ti.com">amplifier.ti.com</a>	Audio	<a href="http://www.ti.com/audio">www.ti.com/audio</a>
Data Converters	<a href="http://dataconverter.ti.com">dataconverter.ti.com</a>	Automotive	<a href="http://www.ti.com/automotive">www.ti.com/automotive</a>
DSP	<a href="http://dsp.ti.com">dsp.ti.com</a>	Broadband	<a href="http://www.ti.com/broadband">www.ti.com/broadband</a>
Interface	<a href="http://interface.ti.com">interface.ti.com</a>	Digital Control	<a href="http://www.ti.com/digitalcontrol">www.ti.com/digitalcontrol</a>
Logic	<a href="http://logic.ti.com">logic.ti.com</a>	Military	<a href="http://www.ti.com/military">www.ti.com/military</a>
Power Mgmt	<a href="http://power.ti.com">power.ti.com</a>	Optical Networking	<a href="http://www.ti.com/opticalnetwork">www.ti.com/opticalnetwork</a>
Microcontrollers	<a href="http://microcontroller.ti.com">microcontroller.ti.com</a>	Security	<a href="http://www.ti.com/security">www.ti.com/security</a>
		Telephony	<a href="http://www.ti.com/telephony">www.ti.com/telephony</a>
		Video & Imaging	<a href="http://www.ti.com/video">www.ti.com/video</a>
		Wireless	<a href="http://www.ti.com/wireless">www.ti.com/wireless</a>

Mailing Address: Texas Instruments  
Post Office Box 655303 Dallas, Texas 75265

Copyright © 2006, Texas Instruments Incorporated