

# Crystal Oscillator and Crystal Selection for the CC13xx, CC26xx and CC23xx Family of Wireless MCUs



James Murdock and Danielle Griffith

## ABSTRACT

The CC13xx, CC26xx and CC23xx family are low-power wireless MCU platforms supporting multiple standards (that is, Bluetooth® low energy, IEEE® 802.15.4, and proprietary RF protocols). The document is valid for all CC13xx, CC26xx and CC23xx family devices, unless otherwise noted. The generic term "CC devices" is used for simplification. The CC devices have integrated 24-MHz (CC13x0 and CC26x0) or 48-MHz (CC13x2, CC26x2, CC23xx) and 32.768-kHz crystal oscillators TI designed for use with low-cost quartz crystals. The 24/48-MHz oscillator (XOSC-HF) generates the reference clock for the RF blocks and the MCU system. RF systems are dependent on accurate clocks for correct operation. A deviation in clock frequency is reflected as a deviation in radio frequency. This deviation can degrade RF performance, violate regulatory requirements, or lead to a nonfunctioning system. In power-down mode, the high-frequency oscillator is typically turned off and a low-frequency oscillator is the system clock. For time-synchronized protocols such as Bluetooth low energy, a tight tolerance on the sleep clock enables longer time in low-power mode and reduced power consumption important in battery-powered applications. For this low-frequency oscillator, typically a 32-kHz crystal oscillator (XOSC-LF) is used.

The scope of this application report is to discuss the requirements and trade-offs of the crystal oscillators for this CC devices and provide information on how to select an appropriate crystal. This document also presents steps to configure the device to operate with a given crystal. You must configure the CC devices based on the crystal used (that is, adjust the internal capacitor array to match the loading capacitor of the crystal for the XOSC-HF). This application report also discusses some measurement approaches that may be used to characterize certain performance metrics, including crystal oscillator amplitude, and start-up time.

## Table of Contents

<b>1 Oscillator and Crystal Basics</b> .....	<b>3</b>
1.1 Oscillator Operation.....	3
1.2 Quartz Crystal Electrical Model.....	3
1.3 Negative Resistance.....	4
1.4 Time Constant of the Oscillator.....	5
<b>2 Overview of Crystal Oscillators for CC devices</b> .....	<b>6</b>
2.1 24-MHz and 48-MHz Crystal Oscillator.....	6
2.2 24-MHz and 48-MHz Crystal Control Loop.....	6
2.3 32.768-kHz Crystal Oscillator.....	7
<b>3 Selecting Crystals for the CC devices</b> .....	<b>8</b>
3.1 Mode of Operation.....	8
3.2 Frequency Accuracy.....	8
3.3 Load Capacitance.....	10
3.4 ESR and Start-Up Time.....	12
3.5 Drive Level and Power Consumption.....	12
3.6 Crystal Package Size.....	12
<b>4 PCB Layout of the Crystal</b> .....	<b>13</b>
<b>5 Measuring the Amplitude of the Oscillations of Your Crystal</b> .....	<b>14</b>
5.1 Measuring Start-Up Time to Determine HPMRAMP1_TH and XOSC_HF_FAST_START.....	14
<b>6 Crystals for CC13xx, CC26xx and CC23xx</b> .....	<b>15</b>
<b>7 High Performance BAW Oscillator</b> .....	<b>17</b>
<b>8 References</b> .....	<b>18</b>

<b>9 Revision History</b> .....	<b>19</b>
---------------------------------	-----------

### List of Figures

Figure 1-1. Pierce Oscillator.....	3
Figure 1-2. Crystal Symbol and the Electrical Model of a Quartz Crystal.....	3
Figure 2-1. Simplified Block Diagram of the CC Devices High-Frequency Oscillator With Quartz Crystal.....	6
Figure 2-2. Simplified Block Diagram of the 32.768-kHz Oscillator With Quartz Crystal.....	7
Figure 3-1. Typical Frequency vs Temperature Curve for a 32.768-kHz Tuning Fork Crystal.....	9
Figure 3-2. The Frequency vs Temperature Curve for the High Frequency Crystal for 13 Closely Spaced Load Capacitance Values.....	11
Figure 3-3. Removing the Offset of the Frequency vs Temperature Curves.....	11
Figure 4-1. Layout of the CC26xx EVM.....	13

### List of Tables

Table 1-1. Crystal Parameters.....	5
Table 3-1. Using External Capacitor Results in Worse Frequency Stability Over Temperature.....	10
Table 6-1. 48-MHz Crystals Suitable for CC13x2, CC26x2 and CC23xx.....	15
Table 6-2. 48-MHz Crystals Suitable for CC23xx only.....	15
Table 6-3. 24-MHz Crystals Suitable for CC13x0 and CC26x0.....	15
Table 6-4. 32.768 kHz Crystals Suitable for CC13xx, CC26xx, and CC23xx.....	16

### Trademarks

SimpleLink™ is a trademark of Texas Instruments.

Bluetooth® is a registered trademark of Bluetooth SIG, Inc.

IEEE® is a registered trademark of Institute of Electrical and Electronics Engineers.

ZigBee® is a registered trademark of ZigBee Alliance.

All trademarks are the property of their respective owners.

## 1 Oscillator and Crystal Basics

This section explains fundamentals of a quartz crystal and the oscillator operations required to understand the trade-offs when selecting a crystal for the CC devices. The complete crystal oscillator circuit includes the loading capacitance, crystal, and the on-chip circuitry.

### 1.1 Oscillator Operation

The circuit used as high-accuracy clock source for TI's low-power RF products is based on a Pierce oscillator as shown in [Figure 1-1](#). There is no on-chip damping resistor and none must be added by the customer. The oscillator circuit consists of an inverting amplifier (shown as an inverter), a feedback resistor, two capacitors, and a crystal. When operating, the crystal and the capacitors form a pi filter that provides an 180-degree phase shift to the internal amplifier, keeping the oscillator locked at the specified frequency.

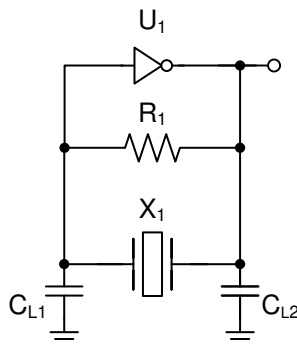

**Figure 1-1. Pierce Oscillator**

### 1.2 Quartz Crystal Electrical Model

A quartz crystal is a piezoelectric device that transforms electric energy to mechanical energy. This transformation occurs at the resonant frequency. [Figure 1-2](#) shows the simplified electric model that describes the quartz crystal, where  $C_0$  is the shunt capacitance,  $L_M$  is motional inductance,  $C_M$  is motional capacitance, and  $R_M$  is motional resistance. The model in [Figure 1-2](#) is a simplified model and includes only the fundamental oscillation frequency. In reality, crystals can also oscillate at odd harmonics of the fundamental frequency.

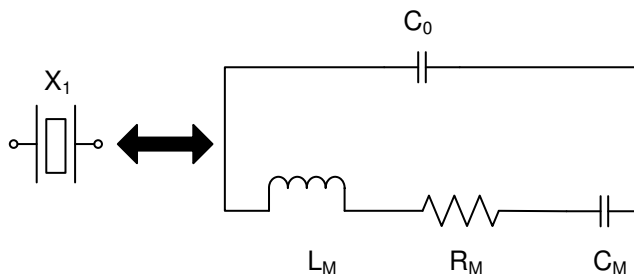

**Figure 1-2. Crystal Symbol and the Electrical Model of a Quartz Crystal**

#### 1.2.1 Frequency of Oscillation

A crystal has two resonant frequencies characterized by a zero-phase shift. [Equation 1](#) is the series resonance.

$$f_s = \frac{1}{2\pi\sqrt{L_M \times C_M}} \quad (1)$$

[Equation 2](#) is the anti-resonant frequency.

$$f_a = \frac{1}{2\pi\sqrt{L_M \times \frac{C_M \times C_0}{C_M + C_0}}} \quad (2)$$

As specified in the data sheet of the crystal, the frequency of oscillation is between the resonance frequencies. See [Equation 3](#).

$$f_s < f_{XTAL} < f_a \quad (3)$$

### 1.2.2 Equivalent Series Resistance

The Equivalent Series Resistance (ESR) is the resistance the crystal exhibits at the series resonant frequency. [Equation 4](#) gives the ESR.

$$ESR = R_M \left( 1 + \frac{C_0}{C_L} \right)^2 \quad (4)$$

Because  $C_0$  is typically on the order of 1 pF and  $C_L$  is 5–9 pF, ESR is approximately  $R_M$  for many crystals, sometimes ESR is approximated as motional resistance.

### 1.2.3 Drive Level

The drive level of a crystal refers to the power dissipated in the crystal. The maximum drive level of a crystal is often specified in the data sheet of the crystal in  $\mu\text{W}$ . Exceeding this value can damage or reduce the life of the crystal. [Equation 5](#) gives the drive level in W.

$$DL = 2 \times ESR (\pi f(C_L + C_0) V_{pp})^2 \quad (5)$$

where,  $V_{pp}$  is the peak-to-peak voltage on the crystal pin.

Calculating the DL and comparing this value to the maximum specified DL in the crystal data sheet may reveal if the crystal is likely to have reliability issues during operation. [Section 5](#) describes how to measure the value of  $V_{pp}$ .

### 1.2.4 Crystal Pulling

The crystal frequency can be pulled by changing the load capacitance. The parameter  $\Delta F$  is the resonance frequency change of the crystal due to a change in its load capacitance. The pulling is given by [Equation 6](#) around the specified (parallel) resonance frequency of the crystal.

$$\Delta F = \frac{F \times C_M}{2} \frac{C_{LMAX} - C_{LMIN}}{(C_0 + C_{LMAX})(C_0 + C_{LMIN})} \quad (6)$$

$C_{LMAX}$  and  $C_{LMIN}$  are the maximum and minimum load capacitance that can be presented to the crystal. For more information, see [CC13xx/CC26xx Hardware Configuration and PCB Design Considerations](#).

## 1.3 Negative Resistance

Negative resistance ( $R_N$ ) is a parameter of the complete oscillator circuit, including capacitor values, crystal parameters, and the on-chip circuit. The CC devices dynamically adjust the oscillator parameters to ensure sufficient oscillator margin during crystal startup and then relax the margins for steady state to decrease the current consumption. This means that when using a crystal within the requirements outlined in the CC data sheets, proper start-up and steady-state margin is ensured over operating conditions.

[Equation 7](#) approximates the negative resistance and shows that a low  $C_L$  gives a larger negative resistance.

$$R_N \approx \frac{-g_m}{(2\pi f)^2 (2C_L)^2} \quad (7)$$

where:

$g_m$  is the transconductance of the active element in the oscillator, and can be approximated as 7 milli-Siemens for the high frequency crystal oscillator and 30 micro-Siemens for the low frequency crystal

$C_L$  is the load capacitance

You can also find the negative resistance of the circuit by introducing a resistor in series with the crystal. To avoid parasitic effects, TI recommends using a 0201 resistor for this task. The threshold of the sum of the extra 0201 external resistance and ESR or the crystal where the oscillator is unable to start up is approximately the same as the circuit negative resistance.

#### 1.4 Time Constant of the Oscillator

The start-up time of a crystal oscillator is determined by transient conditions at turn-on, small-signal envelope expansion due to negative resistance, and large-signal amplitude limiting. The envelope expansion is a function of the total negative resistance and the motional inductance of the crystal. The time constant of the envelope expansion is proportional to the start-up time of the oscillator given by [Equation 8](#).

$$\tau = \frac{-2L_M}{(R_M + R_N)} \approx \frac{-2L_M}{R_N}, |R_n| \gg |R_m| \quad (8)$$

A crystal with a low  $L_M$  gives a shorter start-up time and so does a high-magnitude  $R_N$  (low  $C_L$ ). A trade-off exists between pull-ability due to low-motional capacitance ( $C_M$ ) and fast start-up time due to low-motional inductance ( $L_M$ ), because the frequency of the crystal is dependent on the both  $C_M$  and  $L_M$ . Crystals in smaller package sizes have larger  $L_M$ , and start more slowly than those in larger package sizes (see [Section 1.2.1](#)).

[Table 1-1](#) summarizes crystal parameters and their values for the reference crystals recommended by TI for use with the CC devices.

**Table 1-1. Crystal Parameters**

Parameters	Description	24-MHz Crystal Used in TI CC26x0 Characterization	TI-Assumed Default 32.768-kHz Crystal
Motional Inductance ( $L_M$ )	Partly determines crystal response time (how quickly the crystal responds to a change from the oscillator). Lower $L_m \rightarrow$ crystal responds more quickly to changes from the oscillator. Along with $C_M$ , a major determiner of the crystal quality factor	12.6 mH	5.0 kH
Motional Capacitance ( $C_M$ )	Partly determines crystal response time. Lower $C_M \rightarrow$ crystal responds more slowly to changes from the oscillator.	3.4 fF	4.718 fF
Motional Resistance ( $R_M$ )	At resonance, $L_m$ and $C_M$ cancel and $R_M$ is presented to the oscillator. $R_M \sim$ ESR assuming $C_L \gg C_O$ .	20 $\Omega$ (60- $\Omega$ maximum)	37 k $\Omega$ (70-k $\Omega$ maximum)
Load Capacitance ( $C_L$ )	The amount of load capacitor to tune the crystal to the correct frequency. This load capacitance also helps determine drive level.	9 pF	7 pF
Shunt Capacitance ( $C_O$ )	This is a parasitic capacitance due to crystal packaging. It helps determine the acceptable drive level.	1.2 pF	1 pF
ESR	Equivalent Series Resistance. If $C_L \gg C_O$ , then $ESR \sim R_M$	20 $\Omega$ (60- $\Omega$ maximum)	37 k $\Omega$
Drive Level	The maximum level of power in the crystal for reliable long-term operation, see <a href="#">Equation 5</a>	200 $\mu$ W	<500 nW

## 2 Overview of Crystal Oscillators for CC devices

The CC devices have integrated 24-MHz, 48-MHz and 32.768-kHz crystal oscillators that TI designed for use with low-cost quartz crystals. High-frequency (48 MHz) and low-frequency (32 kHz) RC oscillators are also available on the CC devices, which are beyond the scope of this application note.

### 2.1 24-MHz and 48-MHz Crystal Oscillator

Figure 2-1 shows a simplified block diagram of the XOSC-HF. The oscillator circuit consists of an inverting amplifier, a feedback net, capacitors, and a crystal. The CC devices have an internal capacitor array that can be adjusted and eliminates the requirement for external loading capacitors. The cap-array can be adjusted by the Customer Configuration Flash (CCFG) within a range of 2 pF to 11 pF. For reliable operation, TI requires operating the crystal with  $C_L$  from 5 to 9 pF. [CC13xx/CC26xx Hardware Configuration and PCB Design Considerations](#) shows how to set this value. If no external capacitors are used then the value of  $C_L$  is determined by the internal loading capacitors plus board parasitic capacitance  $C_p$ .

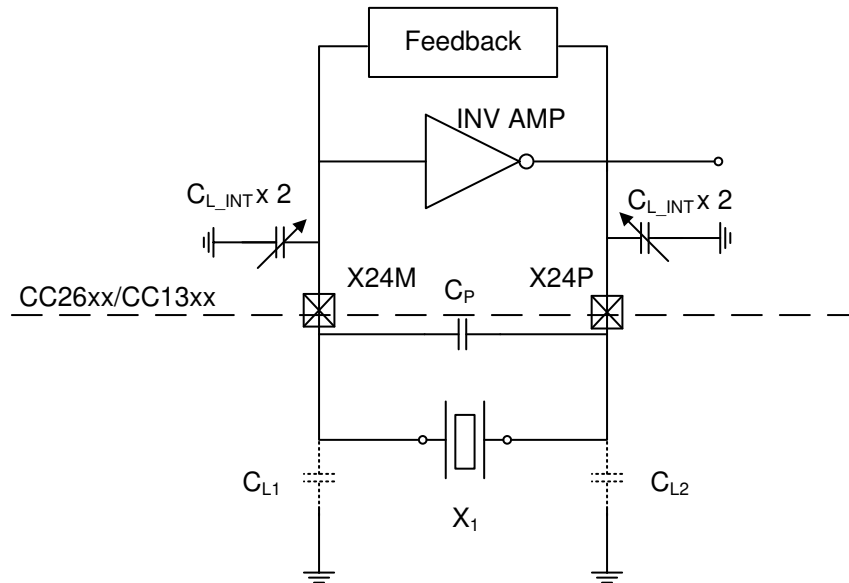

**Figure 2-1. Simplified Block Diagram of the CC Devices High-Frequency Oscillator With Quartz Crystal**

The 24-MHz or 48-MHz crystal is controlled with a control loop described in [Section 2.2](#) and [Section 2.3](#).

### 2.2 24-MHz and 48-MHz Crystal Control Loop

TI intends the amplitude control loop to regulate the amplitude of the oscillations of the crystal for optimal performance. The following are the two primary portions of the control loop:

- Start-up: The control loop injects as much current as possible into the oscillator that drives the crystal resonator to reduce the startup time. Once the amplitude reaches the desired value, the current is reduced to a steady state level.
- Steady state regulation: The amplitude of the crystal oscillator can be regulated in a steady state manner if required.

To turn on the crystal so that the radio can operate, start-up is required. Steady state amplitude regulation is not required for the crystal or radio to function.

### 2.3 32.768-kHz Crystal Oscillator

Figure 2-2 shows a simplified block diagram of the 32.768-kHz crystal oscillator. The oscillator circuit consists of an inverting amplifier, a feedback net, capacitors, and a crystal. The 32-kHz crystal lacks internal capacitors and requires external loading capacitors.

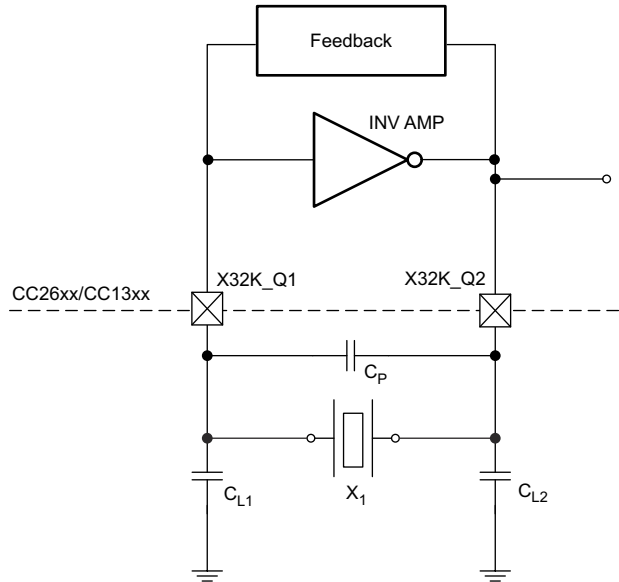

**Figure 2-2. Simplified Block Diagram of the 32.768-kHz Oscillator With Quartz Crystal**

### 3 Selecting Crystals for the CC devices

This section presents some important considerations when selecting crystals for the CC devices. Selecting a crystal for a specific application depends on the following three factors:

- Size (footprint area and height)
- Performance (accuracy over temperature, lifetime, power consumption, and start-up time)
- Cost

Consider the following when selecting a crystal:

- Crystals must be selected to meet requirements listed in the CC data sheets or specifications.
  - ESR must not be greater than can be driven by the CC device.
  - Capacitive loading and frequency tolerance must meet the specifications of the standard used (for example, Blue tooth low energy).
  - Motional inductance must also meet specifications. Many crystal manufactures provide only motional inductance data upon customer request.
- Some other considerations when selecting a crystal include the following:
  - To improve start-up time and reduce power consumption, the crystal must have the following:
    - Low-capacitive loading, at the expense of greater susceptibility to frequency variation caused by the environment
    - Low-motional inductance
    - Low-motional resistance

#### 3.1 Mode of Operation

Quartz crystals are used at the fundamental resonance frequency for frequencies relevant to the CC devices, but there are crystals that operate at an odd overtone of the fundamental frequency. TI recommends using a crystal that operates at the fundamental mode for the CC devices.

#### 3.2 Frequency Accuracy

The total tolerance of the frequency accuracy of a crystal is dependent on several factors:

- Production tolerance
- Temperature tolerance
- Aging effects
- Frequency pulling of the crystal due to mismatched loading capacitance

When selecting the crystal, consider these parameters. [Equation 9](#) gives the total crystal tolerance.

$$Tol_{tot} = Tol_{prod} + Tol_{temp} + Tol_{age} + Tol_{pull} \text{ (ppm)} \quad (9)$$

These values are given in parts per million (ppm) and can be found in the device-specific data sheet of the crystal manufacturer, except pullability, which can be calculated by the formula in [Section 1](#).

##### 3.2.1 24-MHz and 48-MHz Crystal

Because the 24 MHz and 48 MHz crystal oscillators are used as a reference to generate the RF signal, any crystal frequency deviation is directly transferred to deviation of the RF signal. For example, 10 ppm frequency deviation leads a deviation in RF carrier frequency of 10 ppm. Select a crystal with performance within the limits of the RF specifications.

- For 802.15.4 (Thread/ ZigBee®), the maximum deviation in carrier frequency is limited to ±40 ppm (see [\[1\]](#)).
- For Bluetooth® low energy, the limit is ±40 ppm (see [\[2\]](#)).
- Customers of CC13X2 who require frequency accuracy tighter than the crystal can provide can also use a TCXO.



### 3.2.2 32.768-kHz Crystal

The 32.768-kHz crystal oscillator is used as the Read Time Clock (RTC) and is kept running when the device is in Standby mode. Because Bluetooth® low energy is a time-synchronized protocol, an accurate clock also enables longer periods of time in a low-power mode. If a lower-accuracy crystal is used, the device must wake up early to accommodate for the lower accuracy of the clock. To be compliant with Bluetooth® low energy, the clock must have a maximum of  $\pm 500$  ppm of inaccuracy. For more information, see [2]. TI recommends using a tighter tolerance 32.768-kHz crystal to reduce the average power consumption in a typical Bluetooth® low energy connection. In the *SimpleLink™ CC2650 EVM Kit 4XD (CC2650EM-4XD) v1.0.3 Design Files*, TI uses the Epson FC-135 crystal. If a crystal with different specifications is used, this setting must be adjusted for in the Bluetooth® low energy stack. For more details, see the BLE Stack Users Guide.

Note that low-frequency tuning fork crystals have a resonance frequency that changes with temperature with a parabolic coefficient of  $(-0.04 \times 10^{-6}) / ^\circ\text{C}^2$  typically. Figure 3-1 shows an example of this. In Figure 3-1, 40-ppm accuracy is maintained only from  $-10^\circ\text{C}$  to  $50^\circ\text{C}$ .

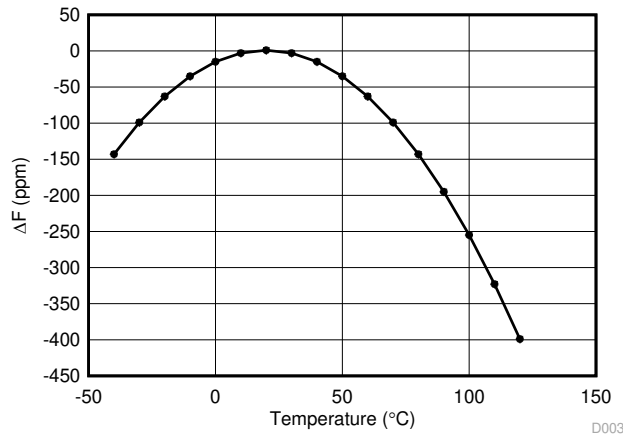

**Figure 3-1. Typical Frequency vs Temperature Curve for a 32.768-kHz Tuning Fork Crystal**

### 3.3 Load Capacitance

The crystal oscillator frequency is dependent on the capacitive loading of the crystal. The crystal data sheet provides the required load capacitance for the crystal,  $C_L$ , for the oscillation to be at the correct frequency. The total  $C_L$  consists of the loading capacitors and the parasitic capacitance of the layout and packaging.  $C_{L1}$  and  $C_{L2}$  are in series with respect to the crystal. Therefore, the effective load capacitance they present is  $C_{L1}/2$ , assuming  $C_{L1}=C_{L2}$ . Extra capacitance between board traces that connect to the crystal will increase the effective  $C_L$ .

Using external capacitors to get the correct frequency means that the internal caps must be set to minimum. For example, an application could use near minimum on-chip capacitance of approximately 2 pF and an off chip capacitance of 7 pF to provide  $C_L=9\text{pF}$  to the crystal. Table 3-1 shows using external caps this way gives slightly worse frequency stability with temperature than using internal capacitors. Certain sub-1GHz users may need to use external load capacitors to reduce spurs at an offset of twice the crystal frequency from the RF carrier frequency.

**Table 3-1. Using External Capacitor Results in Worse Frequency Stability Over Temperature**

	9-pF Internal $C_L$	Minimum Internal $C_L$ /External $C_L$
Frequency variation $-40^\circ\text{C}$ to $+90^\circ\text{C}$	Set by crystal	Set by crystal + 5 ppm
Voltage accuracy, ppm/V	6.9	9

The following presents the relative advantages of crystals with different  $C_L$  values.

The disadvantages of lower  $C_L$  are as follows:

- Crystals with  $< 7\text{-pF}$   $C_L$  are more difficult to source with short lead times.
- Frequency becomes more sensitive to changes in board capacitance as  $C_L$  decreases. It is possible to meet frequency stability specifications with a  $C_L$  as low as 3 pF.
- Lowering  $C_L$  results in degraded RF phase noise.

Advantages of lower  $C_L$  are as follows:

- Lower  $C_L$  causes a much faster start-up time. (Start-up time is proportional to  $C_L^2$ .)
- Lower  $C_L$  causes a faster amplitude control loop response time.
- Lower  $C_L$  makes it easier to use small size crystals ( $2.0 \times 1.6$  and so on) and maintain a start-up time at or less than 400  $\mu\text{s}$ . Start-up time worsens with smaller crystals due to an increase in  $L_M$ .

The internal load capacitance has no appreciable impact on the shape of the frequency vs temperature of the high frequency crystal. This can be seen by looking at the following two plots. Figure 3-2 shows the frequency versus temperature curve for the crystal using 13 different but closely spaced load capacitance. Each different load capacitance shifts the curve up or down, but does not change the overall shape of the curve. This can be seen by removing the offset of each curve, as shown in Figure 3-3.

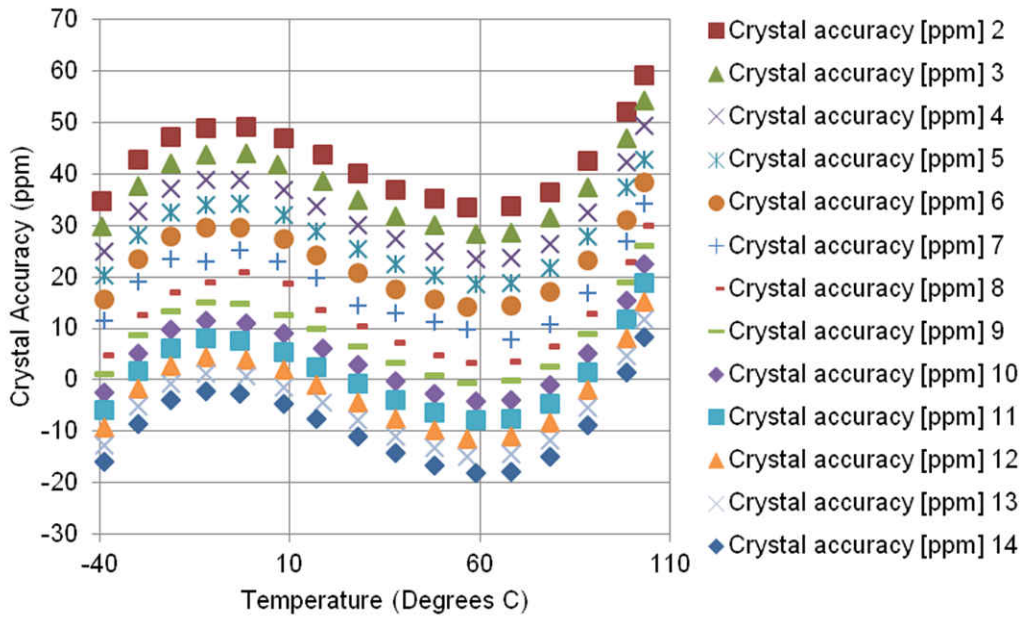

Figure 3-2. The Frequency vs Temperature Curve for the High Frequency Crystal for 13 Closely Spaced Load Capacitance Values

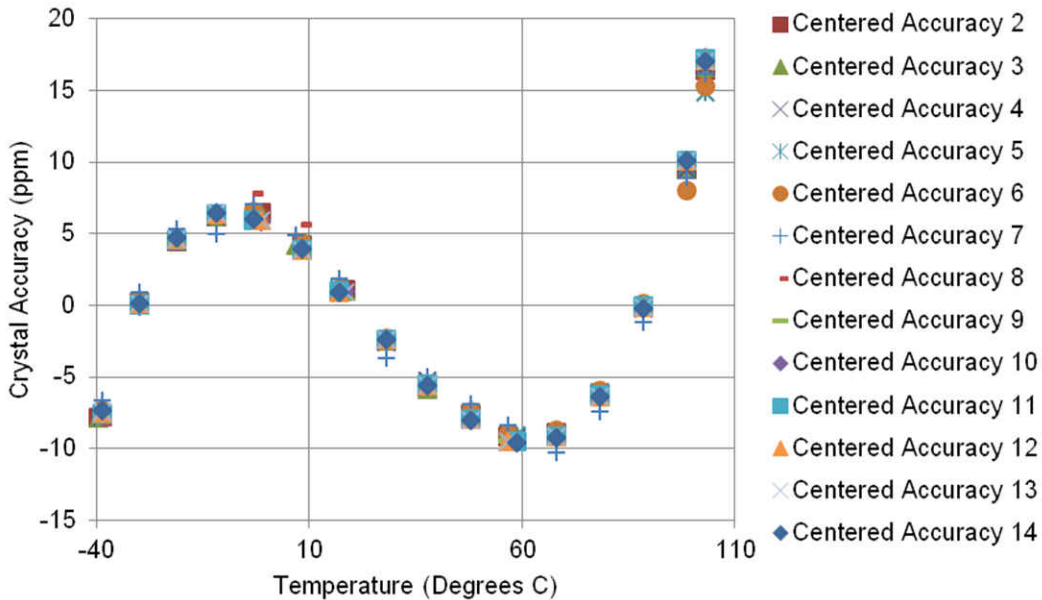

Figure 3-3. Removing the Offset of the Frequency vs Temperature Curves

Figure 3-3 shows that a change in the internal load capacitance does not influence the shape of the frequency vs temperature curve. This indicates that the internal load capacitors have minimal impact on this curve.

A method to change the on-chip load caps of the crystal is discussed in [CC13xx/CC26xx Hardware Configuration and PCB Design Considerations](#).

### 3.4 ESR and Start-Up Time

ESR (equivalent series resistance) is a parameter of the crystal in the data sheet of the crystal. Negative resistance is a parameter of the complete oscillator circuit, including capacitor values, crystal parameters, and an on-chip circuit. To ensure best start-up of the crystal oscillator, the negative resistance magnitude must be at least 3 times greater than  $R_N$  (see [Equation 10](#) and [Equation 11](#)) during initial start-up.

$$ESR < \frac{|R_N|}{3} \quad (10)$$

$$R_N = \frac{-g_m}{(2\pi f)^2 (2C_L)^2} \quad (11)$$

If the negative resistance magnitude is not 3× greater than ESR during initial start-up, the oscillator might not operate optimally or might fail to start in the presence of environmental changes or manufacturing variations in the crystal.

---

#### Note

Crystals with higher ESR typically result in longer start-up times than crystals with lower ESR. A higher-load capacitance decreases the negative resistance of the oscillator and increases the start-up time.

---

### 3.5 Drive Level and Power Consumption

The maximum drive level of a crystal is often specified in the data sheet of the crystal in  $\mu\text{W}$ . Exceeding this value can damage or reduce the lifetime the crystal. The CC13xx and CC26xx devices drive the crystal with a maximum  $1.6 V_{pp\_differential}$  for the 24/48-MHz crystal and  $600 \text{ mV}_{pp\_differential}$  for the 32.768-kHz crystal. As [Section 1.2.3](#) explains, [Equation 5](#) gives the drive level in W.

A higher total capacitance load and ESR require more power to drive the crystal, increasing the power consumption of the oscillator. Because the 32.768-kHz crystal is on for an extended period of time, this increase is important. Selecting a low ESR and low- $C_L$  32.768-kHz crystal is important to achieve low-power consumption in a low-power mode.

---

#### Note

Do not use the internal DC-DC when applying a probe to the probe to the 24 MHz or 48 MHz crystal oscillator pins. Applying the probe can lead to the oscillator stopping and may lead to the internal DC-DC producing a high-output voltage that may damage the device.

---

### 3.6 Crystal Package Size

There are several different packages for crystals. The available board space and cost determines the package size used. Crystals with smaller packages have a higher ESR and motional inductance. These smaller packages cause a longer start-up time of the crystal oscillator. By choosing a crystal with a low  $C_L$  if a smaller package is required, this start-up time increase can be compensated.

## 4 PCB Layout of the Crystal

The layout of the crystal can reduce the parasitic capacitance and, more importantly, reduce noise from coupling on the input of the oscillators. Noise on the input of the oscillator can lead to severe side effects such as clock glitches, flash corruption, or system crashes because the CC26xx and CC13xx devices rely on the crystal oscillators as the high- and low-frequency system clock.

The following are a few recommendations for the layout of the crystals:

- Place the crystal as close as possible to the device to minimize the length of the PCB traces. (This placement reduces crosstalk and minimizes EMI.)
- TI recommends a solid ground plane under the crystal.
- Ensure no high-speed digital signals are close to the crystal to minimize cross-coupling of noise into the oscillator.

Figure 4-1 shows the top layer of the layout of the CC26xx reference design. The bottom layer is a solid ground plane. For more details, see the [SimpleLink™ CC2650 EVM Kit 4XD \(CC2650EM-4XD\) v1.0.3 Design Files](#). The same crystal layout can be used with CC13xx device.

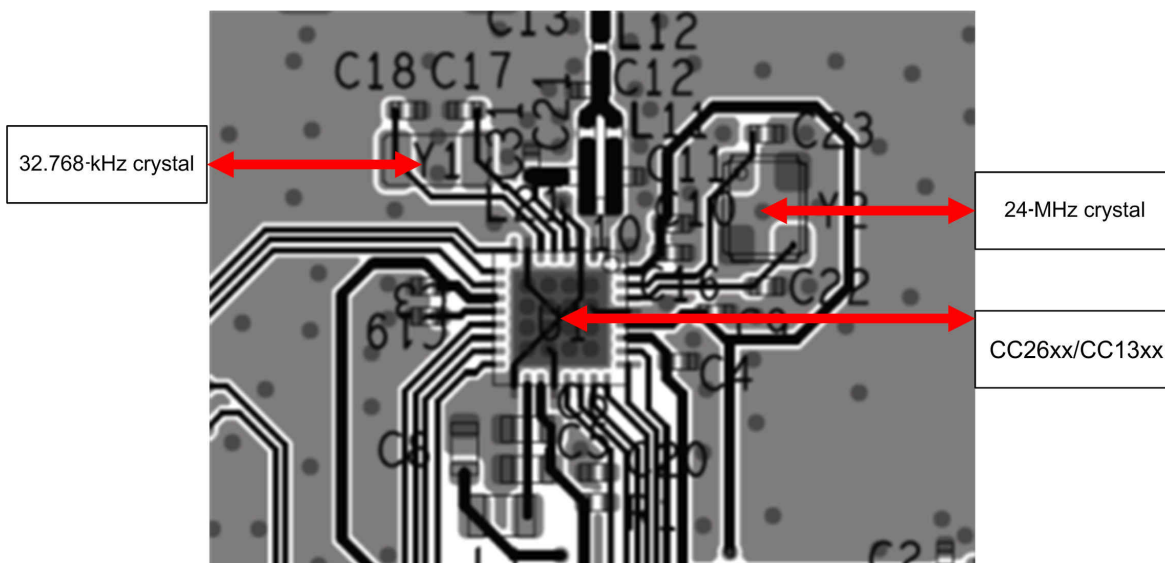

Figure 4-1. Layout of the CC26xx EVM

## 5 Measuring the Amplitude of the Oscillations of Your Crystal

Two functions exist in CC26XX/13XXWARE for measuring the amplitude of the oscillations of the crystal, and comparing this amplitude to the expected amplitude. These functions are as follows:

- `uint32_t OSCHF_DebugGetCrystalAmplitude( void );`
- `uint32_t OSCHF_DebugGetExpectedAvarageCrystalAmplitude( void );`

The first function inserted into a piece of code returns the amplitude of the crystal in mV. The second function returns the expected oscillation amplitude, also in mV. These are debug functions only. The first function uses an on-chip ADC to measure the amplitude of the crystal. If these functions return greatly different values, the crystal may have a problem. The uncertainty of the first function is  $\pm 50$  mV; a 50 mV deviation from the expected value is not cause for concern.

### 5.1 Measuring Start-Up Time to Determine HPMRAMP1\_TH and XOSC\_HF\_FAST\_START

The following code can be used to measure the approximate turn on time of the high frequency crystal for CC26X2 and CC13X2 devices. This function works by counting the number of low frequency clock edges from the enabling of the high frequency clock to the high frequency clock being qualified. For more accurate results, external measurement equipment is required.

```
uint32_t OSCHF_DebugGetCrystalStartupTime( void )
{
    uint32_t lfEdgesFound = 0 ;
    // Start operation in sync with the LF clock
    HWREG( AON_RTC_BASE + AON_RTC_O_SYNCLF );
    OSCHF_TurnOnXosc();
    while ( ! OSCHF_AttemptToSwitchToXosc() ) {
        HWREG( AON_RTC_BASE + AON_RTC_O_SYNCLF );
        lfEdgesFound ++ ;
    }
    OSCHF_SwitchToRCOscTurnOffXosc();
    return ( lfEdgesFound );
}
```

For CC26XX and CC13XX, and CC26X2 and CC13X2 devices, the crystal startup time may also be measured using built in driverlib implementation of `OSCHF_DebugGetCrystalStartupTime()`.

## 6 Crystals for CC13xx, CC26xx and CC23xx

Table 6-1 through Table 6-4 provide appropriate crystals for use with the CC devices.

**Table 6-1. 48-MHz Crystals Suitable for CC13x2, CC26x2 and CC23xx**

Manufacturer	MPN	Package	ESR max [Ω]	CL [pF]	Tol [ppm]	Temp tol [ppm]	Temp range [°C]	Compliant	Comment
Kyocera	CX2016DB 48000C0FPLC1	2016	30	7	±10	±20	-40/85		Used on LAUNCHXL-CC26X2R1
Kyocera	CX2016DB 48000C0FRLC1	2016	30	7	±10	±20	-40/105	AEC-Q200	Meet requirements, but not tested
NDK	NX2016SA 48.000MHz EXS00A-CS05517	2016	40	7	±10	±30	-40/85		Used on CC26x2REM-7ID for characterization
TXC	8Y48072007	2016	40	8	-3/+7	-14/+12	-40/95		
Tai-Saw (TST)	TZ2365D	2016	40	7	±10	±25	-40/105	AEC-Q200	Used on CC26x2REM-7ID-Q1 for characterization

**Table 6-2. 48-MHz Crystals Suitable for CC23xx only**

Recommended for CC23xx only because of the higher negative resistance of this device. We will increase this list as more crystals are evaluated

Manufacturer	MPN	Package	ESR max [Ω]	CL [pF]	Tol [ppm]	Temp tol [ppm]	Temp range [°C]	Compliant	Comment
NDK	NX2016SA 48.000MHz EXS00A-CS14953	2016	40	8		±40 Over all	-40/105		Tested by NDK on Launchpad LP-EM-CC2340R5_E3
NDK	NX1612SA 48MHz EXS00A-CS15039	1612	50	8		±40 Over all	-40/125	AEC-Q200	Tested by NDK on Launchpad LP-EM-CC2340R5_E3
Tai-Saw (TST)	TZ3908AAAO43	2016	30	7	±5	±30	-40/125	AEC-Q200	Used on Launchpad LP-EM-CC2340R5_E3 and characterization

**Table 6-3. 24-MHz Crystals Suitable for CC13x0 and CC26x0**

Manufacturer	MPN	Package	ESR max [Ω]	CL [pF]	Tol [ppm]	Temp tol [ppm]	Temp range [°C]	Compliant	Comment
Epson	TSX-3225 24.0000MF15X-AC3	3225	60	9	±10	±10	-40/85		Used in characterization (EMs)
Epson	TSX-3225 24.0000MF10Z-AC3	3225	60	9	±10	±10	-20/75		Similar spec to F15X, but narrower temperature range.
Epson	TSX-3225 X1E00002104800	3225	40	9	±10	±20	-40/105	AEC-Q200	CC2640Q1EM
NDK	NX2016SA 24 MHz EXS00A-CS08891	2016	60	6	±10	±15	-30/85		Used in CC2640R2F WCSP char.
NDK	NX2016SA 24 MHz EXS00A-CS07553	2016	60	7	±10	±15	-30/85		Tested by NDK
NDK	NX3225SA 24 MHz EXS00A-CS07532	3225	50	9	±10	±15	-30/85		Tested by NDK
Kyocera	CX2016DB 24000C0WPRC1	2016	60	7	±10	±15	-40/85		Tested by Kyocera
Kyocera	CX2016SA 24000C0FRNC1	2016	30	7	±10	±25	-40/105	AEC-Q200	
TXC	8Q24030001	1612	70	5.8	±15	±15	-30/85		Tested by TXC
Murata	XRCGB 24M000FBP12R0	2016	80	6	±15	±20	-40/85		Tested by Murata

**Table 6-4. 32.768 kHz Crystals Suitable for CC13xx, CC26xx, and CC23xx**

Manufacturer	MPN	Package	ESR max [Ω]	CL [pF]	Tol [ppm]	Parabolic coefficient [ppm/°C <sup>2</sup> ]	Temp range [°C]	Compliant	Comment
Epson	FC-135	3215	70k	7	±20	-0.04	-40/85		Lowest current consumption. Used in characterization (EMs)
Epson	FC-13A X1A000091001214	3215	70k	7	±20	-0.04	-40/125	AEC-Q200	Used on LaunchPad CC26x2REM-7ID-Q1_A1
Epson	FC-12M	2012	90k	13	±20	-0.04	-40/85		Smallest size. 200 nA higher current consumption than FC-135 when using GLDO.
NDK	NX3215SA 32.768kHz EXS00A-MU00529	3215	70k	7	±20	-0.04	-40/85		Lowest current consumption. Used in characterization
NDK	NX2012SA 32.768kHz EXS00A-MU00530	2012	80k	7	±20	-0.04	-40/85		
NDK	NX2012SA 32.768kHz EXS00A-MU01792	2012	120k	9	±20	-0.04	-40/125	AEC-Q200	Tested by NDK on Launchpad LP-EM-CC2340R5_E3
Seiko Instruments Inc.	SC-32S 6pF	3215	70k	7	±20	-0.03	-40/85		Tested by Seiko
Seiko Instruments Inc.	SC-20S 7pF	2012	70k	7	±20	-0.03	-40/85		Tested by Seiko
Seiko Instruments Inc.	SC-16S 7pF	1610	90k	7	±20	-0.035	-40/85		Tested by Seiko
Kyocera	ST3215SB 32768C0HPWBB	3215	70k	7	±20	-0.05	-40/85		Tested by Kyocera
Kyocera	ST2012SB 32768C0HPWB4	2012	70k	7	±20	-0.05	-40/85		Tested by Kyocera
Tai-Saw (TST)	TZ3359DAAO73	1610	120k	7	±20	-0.04	-40/125		Used on Launchpad LP-EM-CC2340R5_E3 and characterization
TXC	9H03270072	2012	90k	7	±20	-0.04	-40/105		



## 7 High Performance BAW Oscillator

The SimpleLink™ product family also has a high performance Bulk Acoustic Wave (BAW) oscillator offering that can be used to enable crystal-less radio operation. Multiple technical documents are available that describe this breakthrough technology on TI.com at [SimpleLink™ 32-bit Arm Cortex-M4F Multiprotocol 2.4 GHz Wireless MCU with Crystal-less BAW Resonator](#)

## 8 References

1. [Part 15.4: Wireless Medium Access Control \(MAC\) and Physical Layer \(PHY\) Specifications for Low-Rate Wireless Personal Area Networks \(WPANs\), 802.15.4-2006.](#)
2. [Bluetooth Core Specifications, Version 4.2.](#)
3. Texas Instruments, [CC13xx/CC26xx Hardware Configuration and PCB Design Considerations](#), application note.
4. Texas Instruments, [CC2650 SimpleLink™ Multistandard Wireless MCU](#), data sheet.
5. Texas Instruments, [SimpleLink™ CC2650 EVM Kit 4XD \(CC2650EM-4XD\) v1.0.3 Design Files.](#)
6. Texas Instruments, [CC13x0, CC26x0 SimpleLink™ Wireless MCU](#), technical reference manual.

## 9 Revision History

---

### Changes from Revision I (August 2021) to Revision J (June 2023) Page

- Changed tables, added crystals, changed header (Temp tol [ppm]) on 32.768kHz table..... 15

---

### Changes from Revision H (June 2020) to Revision I (August 2021) Page

- Updated the numbering format for tables, figures and cross-references throughout the document..... 3

---

### Changes from Revision G (August 2019) to Revision H (June 2020) Page

- Changed *Drive Level* topic..... 4
  - Changed *Negative Resistance* topic..... 4
  - Changed *Time Constant of the Oscillator* topic..... 5
  - Changed *24-MHz and 48-MHz Crystal* ..... 8
  - Changed *Load Capacitance* topic..... 10
  - Changed *ESR and Start-Up Time* topic..... 12
  - Changed *Drive Level and Power Consumption* topic..... 12
  - Changes in *Measuring Start-Up Time to Determine HPMRAMP1\_TH and XOSC\_HF\_FAST\_START* topic... 14
  - Added new *High Performance BAW Oscillator* topic..... 17
-

## IMPORTANT NOTICE AND DISCLAIMER

TI PROVIDES TECHNICAL AND RELIABILITY DATA (INCLUDING DATA SHEETS), DESIGN RESOURCES (INCLUDING REFERENCE DESIGNS), APPLICATION OR OTHER DESIGN ADVICE, WEB TOOLS, SAFETY INFORMATION, AND OTHER RESOURCES "AS IS" AND WITH ALL FAULTS, AND DISCLAIMS ALL WARRANTIES, EXPRESS AND IMPLIED, INCLUDING WITHOUT LIMITATION ANY IMPLIED WARRANTIES OF MERCHANTABILITY, FITNESS FOR A PARTICULAR PURPOSE OR NON-INFRINGEMENT OF THIRD PARTY INTELLECTUAL PROPERTY RIGHTS.

These resources are intended for skilled developers designing with TI products. You are solely responsible for (1) selecting the appropriate TI products for your application, (2) designing, validating and testing your application, and (3) ensuring your application meets applicable standards, and any other safety, security, regulatory or other requirements.

These resources are subject to change without notice. TI grants you permission to use these resources only for development of an application that uses the TI products described in the resource. Other reproduction and display of these resources is prohibited. No license is granted to any other TI intellectual property right or to any third party intellectual property right. TI disclaims responsibility for, and you will fully indemnify TI and its representatives against, any claims, damages, costs, losses, and liabilities arising out of your use of these resources.

TI's products are provided subject to [TI's Terms of Sale](#) or other applicable terms available either on [ti.com](https://www.ti.com) or provided in conjunction with such TI products. TI's provision of these resources does not expand or otherwise alter TI's applicable warranties or warranty disclaimers for TI products.

TI objects to and rejects any additional or different terms you may have proposed.

Mailing Address: Texas Instruments, Post Office Box 655303, Dallas, Texas 75265  
Copyright © 2023, Texas Instruments Incorporated