

## OPA2333-Q1 Automotive, 1.8-V, Micropower, CMOS, Zero-Drift Operational Amplifier

### 1 Features

- AEC qualified for automotive applications
  - Temperature grade 1:  $-40^{\circ}\text{C}$  to  $+125^{\circ}\text{C}$ ,  $T_A$
- Low offset voltage:  $23\ \mu\text{V}$  (Max)
- 0.01-Hz to 10-Hz noise:  $1.1\ \mu\text{V}_{PP}$
- Quiescent current:  $17\ \mu\text{A}$
- Single-supply operation
- Supply voltage:  $1.8\ \text{V}$  to  $5.5\ \text{V}$
- Rail-to-rail input/output
- Packages: 8-pin SOIC and VSSOP

### 2 Applications

- [Pump](#)
- [Position sensor](#)
- [Vehicle occupant detection sensor](#)
- Brake system
- Airbag

### 3 Description

The OPA2333-Q1 CMOS operational amplifiers use a proprietary autocalibration technique to simultaneously provide very low offset voltage ( $10\ \mu\text{V}$ , max), and near-zero drift over time and temperature. These miniature high-precision low-quiescent-current amplifiers offer high-impedance inputs that have a common-mode range  $100\ \text{mV}$  beyond the rails and rail-to-rail output that swings within  $50\ \text{mV}$  of the rails. Single or dual supplies as low as  $1.8\ \text{V}$  ( $\pm 0.9\ \text{V}$ ), and up to  $5.5\ \text{V}$  ( $\pm 2.75\ \text{V}$ ) can be used. This device is optimized for low-voltage single-supply operation.

The OPA2333-Q1 offers excellent common-mode rejection ratio (CMRR) without the crossover associated with traditional complementary input stages. This design results in superior performance for driving analog-to-digital converters (ADCs) without degradation of differential linearity.

The OPA2333-Q1 is specified for operation from  $-40^{\circ}\text{C}$  to  $+125^{\circ}\text{C}$ .

#### Device Information<sup>(1)</sup>

PART NUMBER	PACKAGE	BODY SIZE (NOM)
OPA2333-Q1	SOIC (8)	4.90 mm x 3.91 mm
	VSSOP (8)	3.00 mm x 3.00 mm

(1) For all available packages, see the package option addendum at the end of the data sheet.

#### 0.1-Hz to 10-Hz Noise

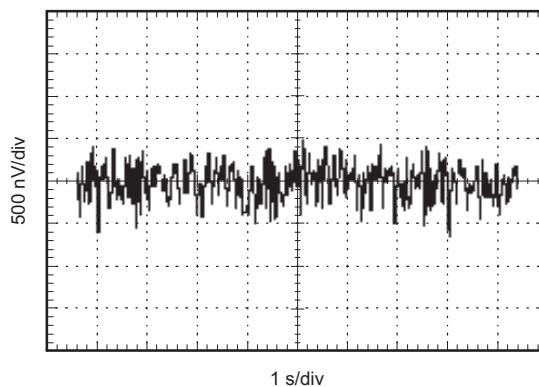

## Table of Contents

<b>1 Features</b> .....	<b>1</b>	7.4 Device Functional Modes.....	<b>9</b>
<b>2 Applications</b> .....	<b>1</b>	<b>8 Application and Implementation</b> .....	<b>10</b>
<b>3 Description</b> .....	<b>1</b>	8.1 Application Information.....	<b>10</b>
<b>4 Revision History</b> .....	<b>2</b>	8.2 Typical Application .....	<b>11</b>
<b>5 Pin Configuration and Functions</b> .....	<b>3</b>	<b>9 Power Supply Recommendations</b> .....	<b>15</b>
<b>6 Specifications</b> .....	<b>4</b>	<b>10 Layout</b> .....	<b>15</b>
6.1 Absolute Maximum Ratings .....	4	10.1 Layout Guidelines .....	15
6.2 ESD Ratings.....	4	10.2 Layout Example .....	15
6.3 Recommended Operating Conditions.....	4	<b>11 Device and Documentation Support</b> .....	<b>16</b>
6.4 Thermal Information .....	4	11.1 Documentation Support .....	16
6.5 Electrical Characteristics: $V_S = 1.8\text{ V to }5.5\text{ V}$ .....	5	11.2 Receiving Notification of Documentation Updates .....	16
6.6 Typical Characteristics .....	6	11.3 Support Resources .....	16
<b>7 Detailed Description</b> .....	<b>9</b>	11.4 Trademarks .....	16
7.1 Overview .....	9	11.5 Electrostatic Discharge Caution.....	16
7.2 Functional Block Diagram .....	9	11.6 Glossary .....	16
7.3 Feature Description.....	9	<b>12 Mechanical, Packaging, and Orderable Information</b> .....	<b>16</b>

## 4 Revision History

### Changes from Revision A (June 2010) to Revision B

**Page**

<ul style="list-style-type: none"> <li>Added <i>Device Information</i> table, <i>Pin Functions</i> table, <i>ESD Ratings</i> table, <i>Recommended Operating Conditions</i> table, <i>Thermal Information</i> table, <i>Feature Description</i> section, <i>Device Functional Modes</i> section, <i>Application and Implementation</i> section, <i>Power Supply Recommendations</i> section, <i>Layout</i> section, <i>Device and Documentation Support</i> section, and <i>Mechanical, Packaging, and Orderable Information</i> section .....</li> </ul>	<b>1</b>
<ul style="list-style-type: none"> <li>Changed input offset voltage (over full temp range) from 22 <math>\mu\text{V}</math> to 15 <math>\mu\text{V}</math> in <i>Electrical Characteristics</i> table .....</li> </ul>	<b>5</b>
<ul style="list-style-type: none"> <li>Added maximum value of 0.05 <math>\mu\text{V}/^\circ\text{C}</math> to the <math>V_{OS}</math> drift parameter in the <i>Electrical Characteristics</i> table .....</li> </ul>	<b>5</b>
<ul style="list-style-type: none"> <li>Deleted <i>Thermal resistance</i> parameter from <i>Electrical Characteristics</i> table .....</li> </ul>	<b>5</b>

## 5 Pin Configuration and Functions

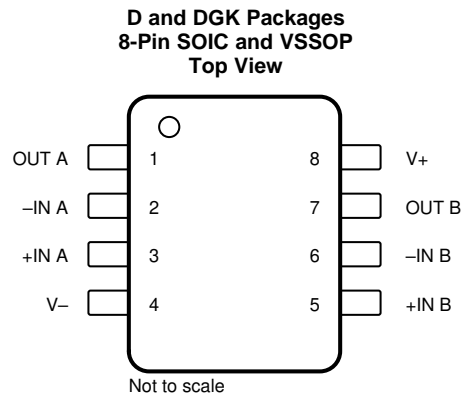

### Pin Functions

PIN		I/O	DESCRIPTION
NO.	NAME		
1	OUT A	O	Channel A output
2	-IN A	I	Channel A inverting input
3	+IN A	I	Channel A noninverting input
4	V-	—	Negative (lowest) supply voltage
5	+IN B	I	Channel B noninverting input
6	-IN B	I	Channel B inverting input
7	OUT B	O	Channel B output
8	V+	—	Positive (highest) supply voltage

## 6 Specifications

### 6.1 Absolute Maximum Ratings

over operating free-air temperature range (unless otherwise noted)<sup>(1)</sup>

		MIN	MAX	UNIT
V <sub>CC</sub>	Supply voltage		7	V
V <sub>I</sub>	Input voltage, signal input pins <sup>(2)</sup>	–0.3	(V+) + 0.3	V
	Output short-circuit <sup>(3)</sup>	Continuous		
T <sub>A</sub>	Operating free-air temperature	–40	125	°C
T <sub>J</sub>	Operating virtual-junction temperature		150	°C
T <sub>stg</sub>	Storage temperature	–65	150	°C

- (1) Stresses beyond those listed under *Absolute Maximum Ratings* may cause permanent damage to the device. These are stress ratings only, which do not imply functional operation of the device at these or any other conditions beyond those indicated under *Recommended Operating Conditions*. Exposure to absolute-maximum-rated conditions for extended periods may affect device reliability.
- (2) Input terminals are diode clamped to the power-supply rails. Input signals that can swing more than 0.3 V beyond the supply rails should be current limited to 10 mA or less.
- (3) Short circuit to ground, one amplifier per package

### 6.2 ESD Ratings

		VALUE	UNIT
V <sub>(ESD)</sub>	Electrostatic discharge	Human-body model (HBM), per AEC Q100-002 <sup>(1)</sup> HBM ESD classification level 2	±2000
		Charged-device model (CDM), per AEC Q100-011 CDM ESD Classification Level C6	±1000

- (1) AEC Q100-002 indicates that HBM stressing shall be in accordance with the ANSI/ESDA/JEDEC JS-001 specification.

### 6.3 Recommended Operating Conditions

over operating free-air temperature range (unless otherwise noted)

		MIN	NOM	MAX	UNIT
V <sub>S</sub>	Specified supply voltage	1.8		5.5	V
T <sub>A</sub>	Specified free-air temperature	–40		125	°C

### 6.4 Thermal Information

THERMAL METRIC <sup>(1)</sup>		OPA2333-Q1		UNIT
		D (SOIC)	DGK (VSSOP)	
		8 PINS	8 PINS	
R <sub>θJA</sub>	Junction-to-ambient thermal resistance	124.0	180.3	°C/W
R <sub>θJC(top)</sub>	Junction-to-case (top) thermal resistance	73.7	48.1	°C/W
R <sub>θJB</sub>	Junction-to-board thermal resistance	64.4	100.9	°C/W
Ψ <sub>JT</sub>	Junction-to-top characterization parameter	18.0	2.4	°C/W
Ψ <sub>JB</sub>	Junction-to-board characterization parameter	63.9	99.3	°C/W
R <sub>θJC(bot)</sub>	Junction-to-case (bottom) thermal resistance	N/A	N/A	°C/W

- (1) For more information about traditional and new thermal metrics, see the [Semiconductor and IC Package Thermal Metrics](#) application report.

## 6.5 Electrical Characteristics: $V_S = 1.8\text{ V to }5.5\text{ V}$

At  $T_A = 25^\circ\text{C}$ ,  $R_L = 10\text{ k}\Omega$  connected to  $V_S/2$ ,  $V_{CM} = V_S/2$ , and  $V_{OUT} = V_S/2$  (unless otherwise noted).

PARAMETER		TEST CONDITIONS	MIN	TYP	MAX	UNIT
<b>OFFSET VOLTAGE</b>						
$V_{OS}$	Input offset voltage	$V_S = 5\text{ V}$		2	10	$\mu\text{V}$
		$V_S = 5\text{ V}$ , $T_A = -40^\circ\text{C to }+125^\circ\text{C}$			15	$\mu\text{V}$
$dV_{OS}/dT$	$V_{OS}$ drift	$V_S = 5\text{ V}$ , $T_A = -40^\circ\text{C to }125^\circ\text{C}$		0.02	0.05	$\mu\text{V}/^\circ\text{C}$
PSRR	Power-supply rejection ratio	$V_S = 1.8\text{ V to }5.5\text{ V}$ , $T_A = -40^\circ\text{C to }+125^\circ\text{C}$		1	6	$\mu\text{V/V}$
	Long-term stability <sup>(1)</sup>			1 <sup>(1)</sup>		$\mu\text{V}$
	Channel separation, dc			0.1		$\mu\text{V/V}$
<b>INPUT BIAS CURRENT</b>						
$I_B$	Input bias current			$\pm 70$	$\pm 200$	$\text{pA}$
		$T_A = -40^\circ\text{C to }+125^\circ\text{C}$		$\pm 150$		$\text{pA}$
$I_{OS}$	Input offset current			$\pm 140$	$\pm 400$	$\text{pA}$
<b>NOISE</b>						
	Input voltage noise	$f = 0.01\text{ Hz to }1\text{ Hz}$		0.3		$\mu\text{V}_{PP}$
		$f = 0.1\text{ Hz to }10\text{ Hz}$		1.1		$\mu\text{V}_{PP}$
$i_n$	Input current noise	$f = 10\text{ Hz}$		100		$\text{fA}/\sqrt{\text{Hz}}$
<b>INPUT VOLTAGE</b>						
$V_{CM}$	Common-mode supply voltage		$(V-) - 0.1$		$(V+) + 0.1$	$\text{V}$
CMRR	Common-mode rejection ratio	$(V-) - 0.1\text{ V} < V_{CM} < (V+) + 0.1\text{ V}$ , $T_A = -40^\circ\text{C to }+125^\circ\text{C}$	102	130		$\text{dB}$
<b>INPUT CAPACITANCE</b>						
	Differential			2		$\text{pF}$
	Common-mode			4		$\text{pF}$
<b>OPEN-LOOP GAIN</b>						
$A_{OL}$	Open-loop voltage gain	$(V-) + 100\text{ mV} < V_O < (V+) - 100\text{ mV}$ , $R_L = 10\text{ k}\Omega$ , $T_A = -40^\circ\text{C to }+125^\circ\text{C}$	104	130		$\text{dB}$
<b>FREQUENCY RESPONSE</b>						
GBW	Gain-bandwidth product	$C_L = 100\text{ pF}$		350		$\text{kHz}$
SR	Slew rate	$G = 1$		0.16		$\text{V}/\mu\text{s}$
<b>OUTPUT</b>						
	Voltage output swing from rail	$R_L = 10\text{ k}\Omega$		30	50	$\text{mV}$
		$R_L = 10\text{ k}\Omega$ , $T_A = -40^\circ\text{C to }+125^\circ\text{C}$			85	$\text{mV}$
$I_{SC}$	Short-circuit current			$\pm 5$		$\text{mA}$
$C_L$	Capacitive load drive					
	<sup>(2)</sup> Open-loop output impedance	$f = 350\text{ kHz}$ , $I_O = 0\text{ A}$		2		$\text{k}\Omega$
<b>POWER SUPPLY</b>						
$I_Q$	Quiescent current per amplifier	$I_O = 0\text{ A}$		17	25	$\mu\text{A}$
		$I_O = 0\text{ A}$ , $T_A = -40^\circ\text{C to }+125^\circ\text{C}$			30	$\mu\text{A}$
	Turn-on time	$V_S = 5\text{ V}$		100		$\mu\text{s}$

(1) 300-hour life test at  $150^\circ\text{C}$  demonstrated randomly distributed variation of approximately  $1\ \mu\text{V}$ .

(2) See the [Typical Characteristics](#) section.

## 6.6 Typical Characteristics

At  $T_A = 25^\circ\text{C}$ ,  $V_S = 5\text{ V}$ , and  $C_L = 0\text{ pF}$  (unless otherwise noted)

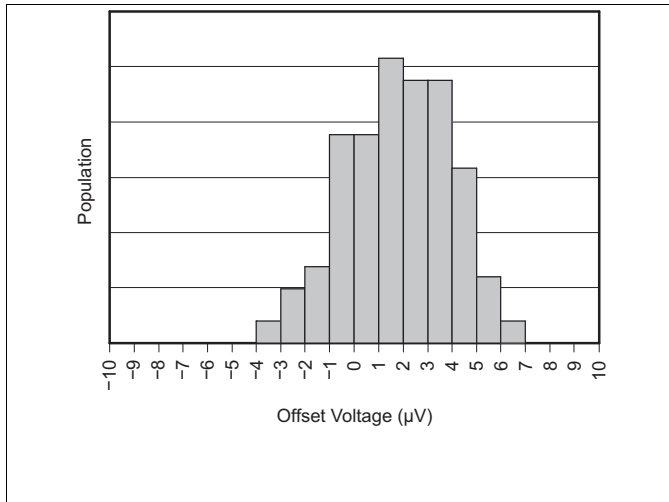

Figure 1. Offset Voltage Production Distribution

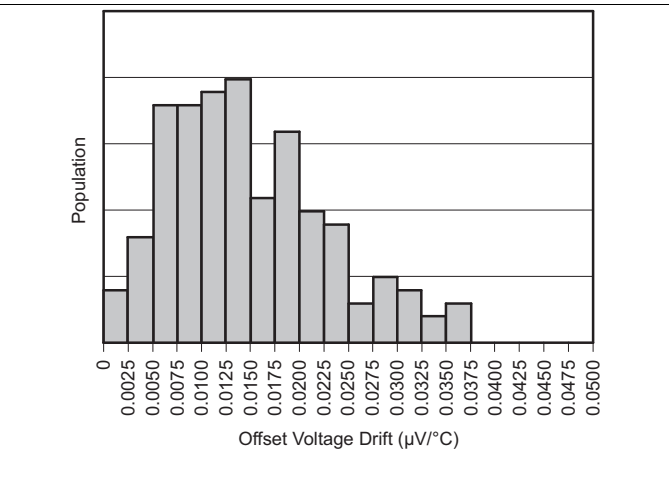

Figure 2. Offset Voltage Drift Production Distribution

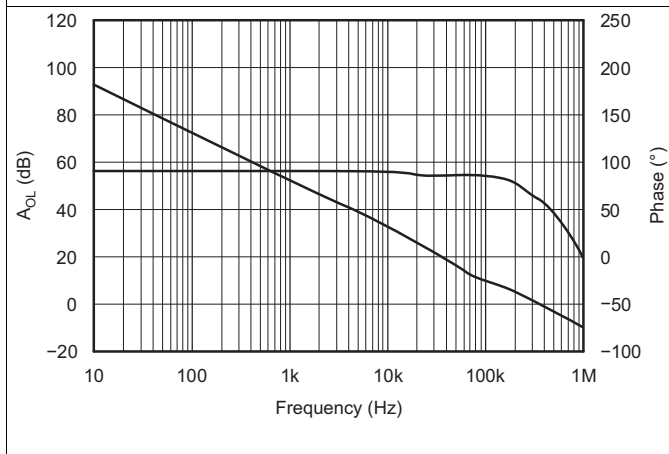

Figure 3. Open-Loop Gain vs Frequency

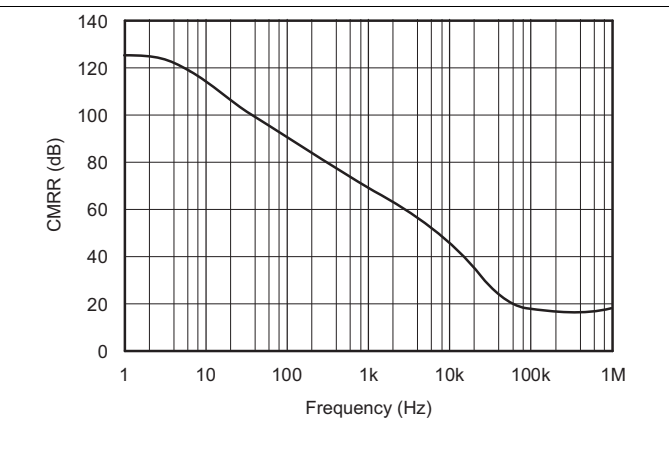

Figure 4. Common-Mode Rejection Ratio vs Frequency

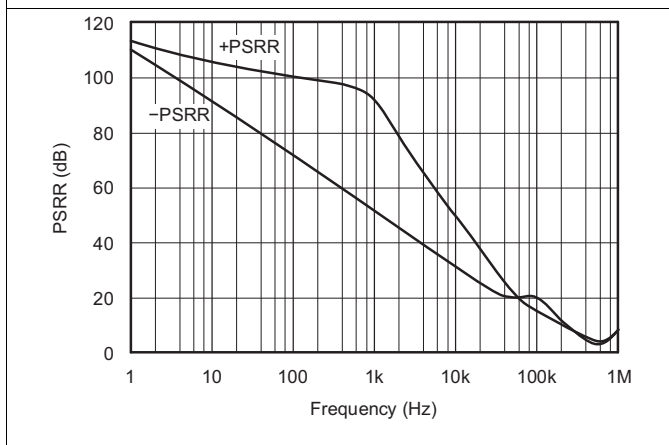

Figure 5. Power-Supply Rejection Range vs Frequency

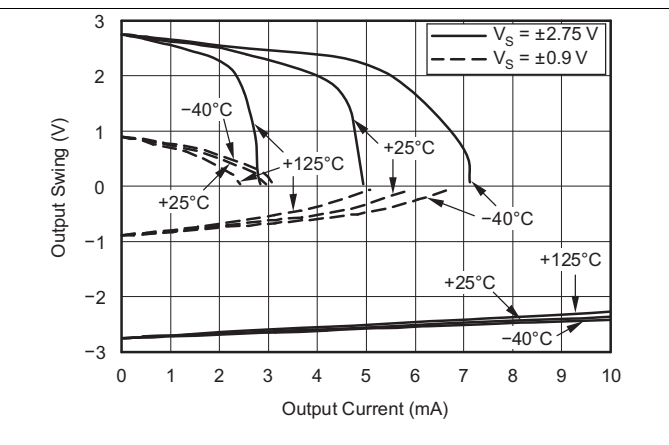
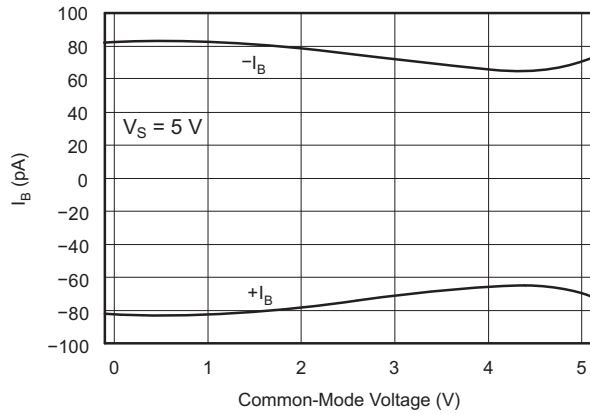

Figure 6. Output Voltage Swing vs Output Current

**Typical Characteristics (continued)**

At  $T_A = 25^\circ\text{C}$ ,  $V_S = 5\text{ V}$ , and  $C_L = 0\text{ pF}$  (unless otherwise noted)



**Figure 7. Input Bias Current vs Common-Mode Voltage**

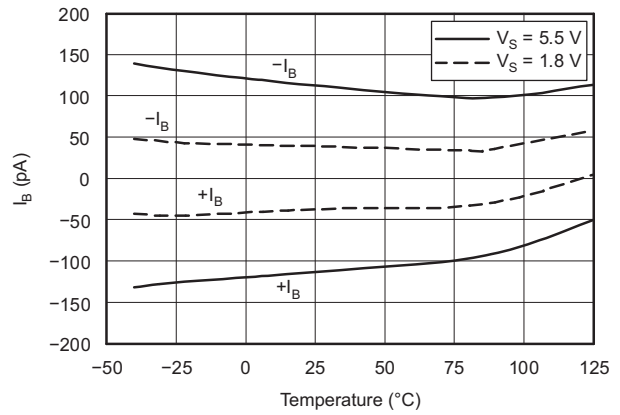

**Figure 8. Input Bias Current vs Temperature**

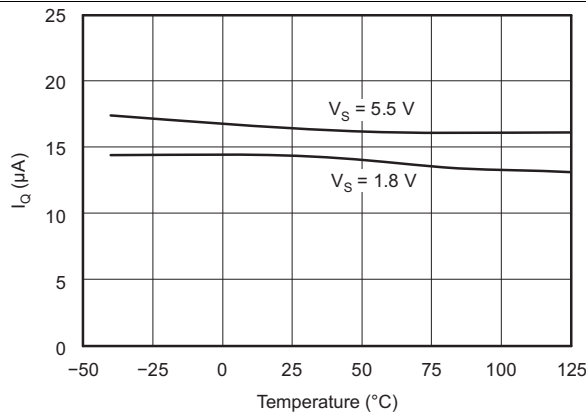

**Figure 9. Quiescent Current vs Temperature**

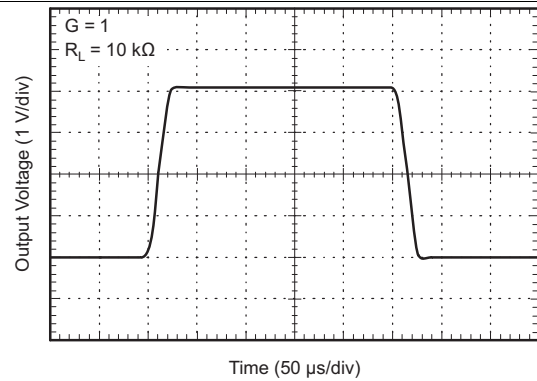

**Figure 10. Large-Signal Step Response**

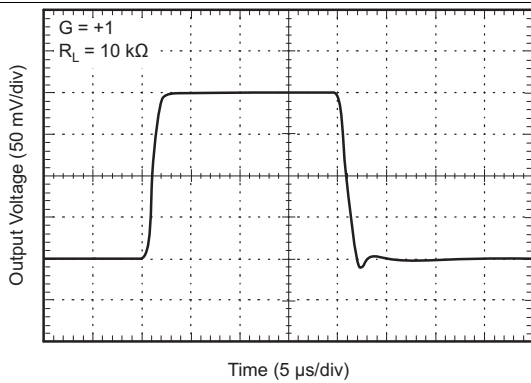

**Figure 11. Small-Signal Step Response**

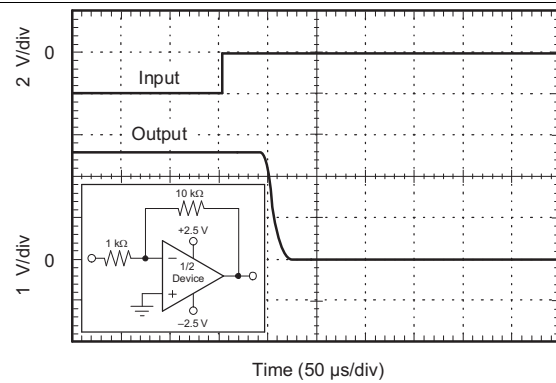

**Figure 12. Positive Over-Voltage Recovery**

Typical Characteristics (continued)

At  $T_A = 25^\circ\text{C}$ ,  $V_S = 5\text{ V}$ , and  $C_L = 0\text{ pF}$  (unless otherwise noted)

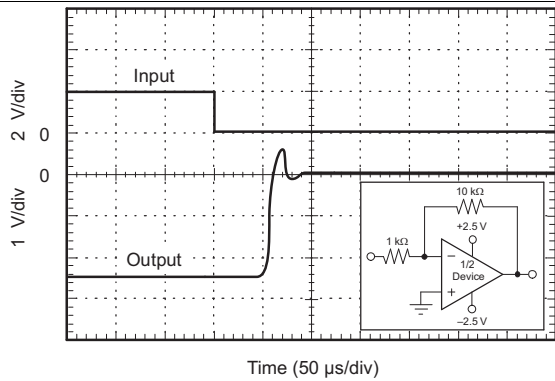

Figure 13. Negative Over-Voltage Recovery

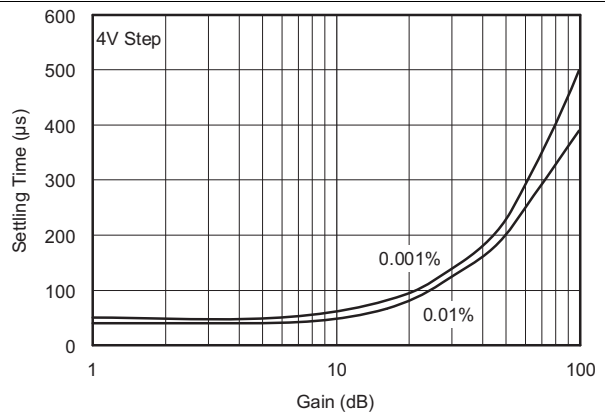

Figure 14. Settling Time vs Closed-Loop Gain

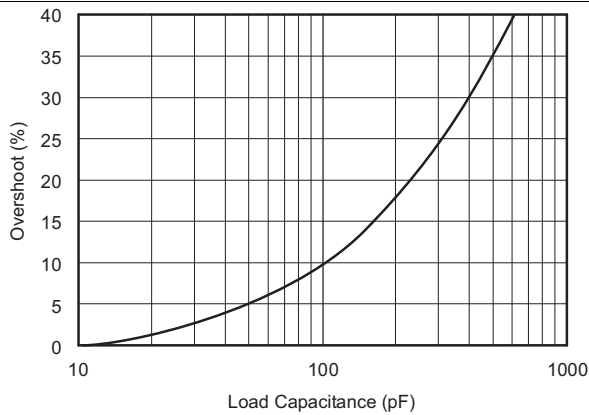

Figure 15. Small-Signal Overshoot vs Load Capacitance

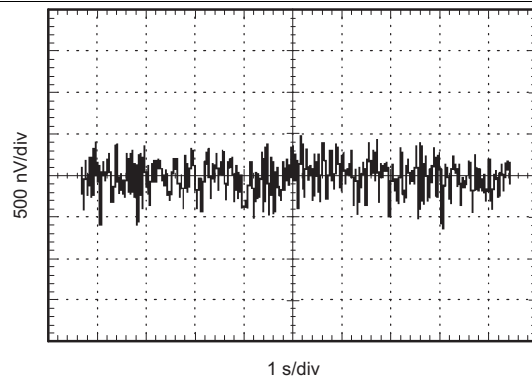

Figure 16. 0.1-Hz to 10-Hz Noise

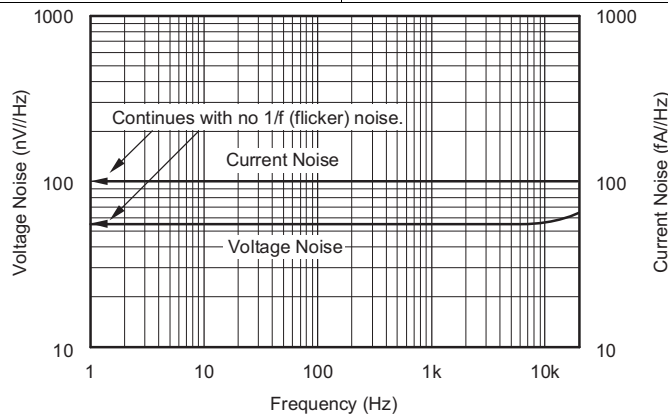

Figure 17. Current and Voltage Spectral Density vs Frequency



## 7 Detailed Description

### 7.1 Overview

The OPA2333-Q1 device is a zero-drift, low-power, rail-to-rail input and output operational amplifier. The device operates from 1.8 V to 5.5 V, is unity-gain stable, and is designed for a wide range of general-purpose applications. The zero-drift architecture provides ultra-low offset voltage and near-zero offset voltage drift.

The OPA2333-Q1 is unity-gain stable and free from unexpected output phase reversal. The device uses a proprietary auto-calibration technique to provide low offset voltage and very low drift over time and temperature.

### 7.2 Functional Block Diagram

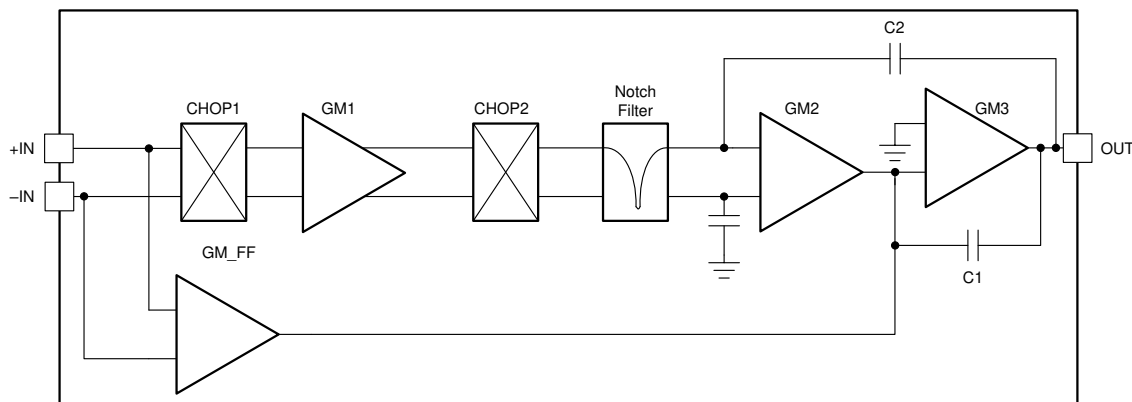

### 7.3 Feature Description

#### 7.3.1 Rail-to-Rail Input Voltage

The OPA2333-Q1 input common-mode voltage range extends 0.1 V beyond the supply rails. The device is designed to cover the full range without the troublesome transition region found in some other rail-to-rail amplifiers.

Normally, input bias current is approximately 70 pA; however, input voltages exceeding the power supplies can cause excessive current to flow into or out of the input pins. Momentary voltages greater than the power supply can be tolerated if the input current is limited to 10 mA. This limitation is easily accomplished with an input resistor (see Figure 18).

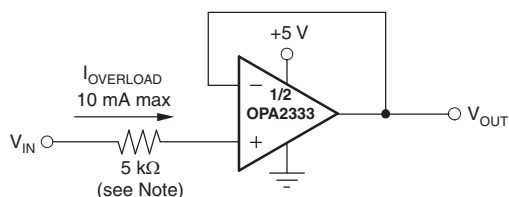

NOTE: A current-limiting resistor required if the input voltage exceeds the supply rails by  $\geq 0.5$  V.

Figure 18. Input Current Protection

#### 7.3.2 Internal Offset Correction

The OPA2333-Q1 op amps use an auto-calibration technique with a time-continuous 350-kHz op amp in the signal path. This amplifier is zero corrected every 8  $\mu$ s using a proprietary technique. At power up, the amplifier requires approximately 100  $\mu$ s to achieve the specified  $V_{OS}$  accuracy. This design has no aliasing or flicker noise.

### 7.4 Device Functional Modes

The OPA2333-Q1 has a single functional mode. The device is powered on as long as the power-supply voltage is between 1.8 V ( $\pm 0.9$  V) and 5.5 V ( $\pm 2.75$  V).

## 8 Application and Implementation

### NOTE

Information in the following applications sections is not part of the TI component specification, and TI does not warrant its accuracy or completeness. TI's customers are responsible for determining suitability of components for their purposes. Customers should validate and test their design implementation to confirm system functionality.

### 8.1 Application Information

The OPA2333-Q1 is a unity-gain stable, precision operational amplifier with very low offset voltage drift. The device is also free from output phase reversal. Applications with noisy or high-impedance power supplies require decoupling capacitors close to the device power-supply pins. In most cases, 0.1- $\mu$ F capacitors are adequate.

#### 8.1.1 Achieving Output Swing to the Op Amp Negative Rail

Some applications require output voltage swings from 0 V to a positive full-scale voltage (such as 2.5 V) with excellent accuracy. With most single-supply op amps, problems arise when the output signal approaches 0 V, near the lower output swing limit of a single-supply op amp. A good single-supply op amp may swing close to single-supply ground, but does not reach ground. The output of the OPA2333-Q1 can be made to swing to ground or slightly below on a single-supply power source. To do so requires the use of another resistor and an additional, more negative, power supply than the op amp negative supply. A pulldown resistor may be connected between the output and the additional negative supply to pull the output down below the value that the output would otherwise achieve (see Figure 19).

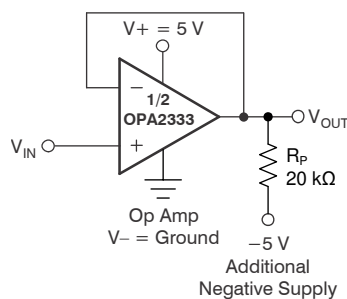

Figure 19.  $V_{OUT}$  Range to Ground

The OPA2333-Q1 has an output stage that allows the output voltage to be pulled to its negative supply rail, or slightly below, using the technique previously described. This technique only works with some types of output stages. The OPA2333-Q1 has been characterized to perform with this technique; however, the recommended resistor value is approximately 20 k $\Omega$ .

### NOTE

This configuration increases the current consumption by several hundreds of microamps.

Accuracy is excellent down to 0 V and as low as -2 mV. Limiting and nonlinearity occurs below -2 mV, but excellent accuracy returns as the output is again driven above -2 mV. Lowering the resistance of the pulldown resistor allows the op amp to swing even further below the negative rail. Resistances as low as 10 k $\Omega$  can be used to achieve excellent accuracy down to -10 mV.

## 8.2 Typical Application

### 8.2.1 High-Side Voltage-to-Current (V-I) Converter

The circuit shown in Figure 20 is a high-side voltage-to-current (V-I) converter. It translates an input voltage of 0 V to 2 V to an output current of 0 mA to 100 mA. Figure 21 shows the measured transfer function for this circuit. The low offset voltage and offset drift of the OPA333-Q1 device facilitate excellent dc accuracy for the circuit.

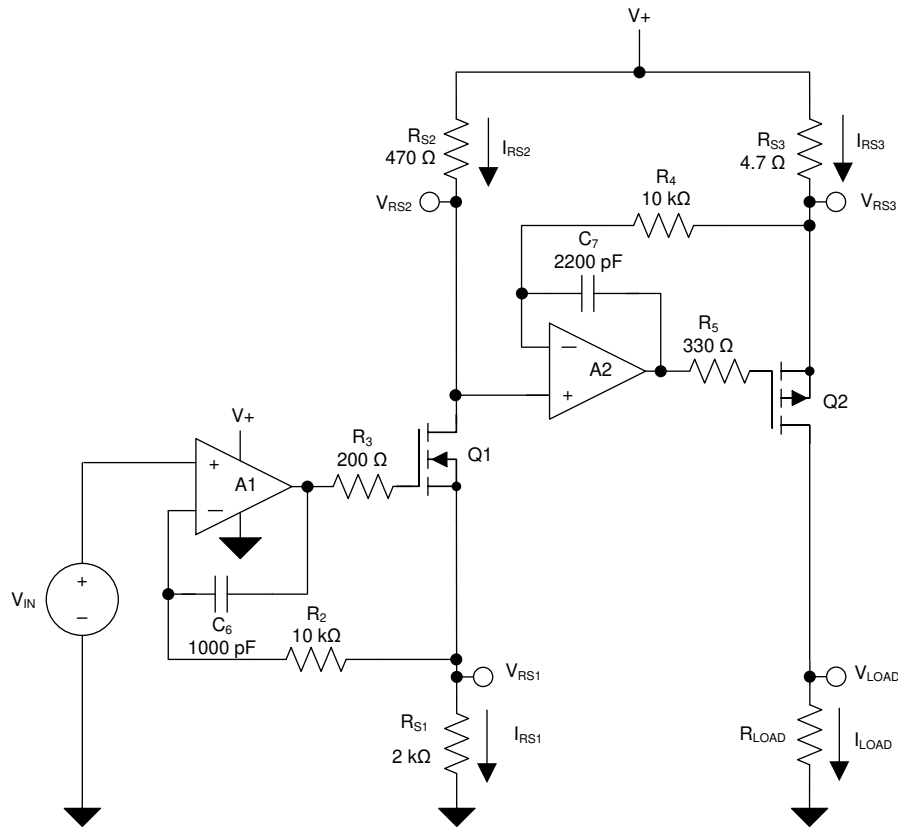

Figure 20. High-Side Voltage-to-Current (V-I) Converter

## Typical Application (continued)

### 8.2.1.1 Design Requirements

The design requirements are as follows:

- Supply voltage: 5 V dc
- Input: 0 V to 2 V dc
- Output: 0 mA to 100 mA dc

### 8.2.1.2 Detailed Design Procedure

The V-I transfer function of the circuit is based on the relationship between the input voltage,  $V_{IN}$ , and the three current sensing resistors,  $R_{S1}$ ,  $R_{S2}$ , and  $R_{S3}$ . The relationship between  $V_{IN}$  and  $R_{S1}$  determines the current that flows through the first stage of the design. The current gain from the first stage to the second stage is based on the relationship between  $R_{S2}$  and  $R_{S3}$ .

For a successful design, pay close attention to the dc characteristics of the operational amplifier chosen for the application. To meet the performance goals, this application benefits from an operational amplifier with low offset voltage, low temperature drift, and rail-to-rail output. The OPA2333-Q1 CMOS operational amplifier is a high-precision, 5- $\mu$ V offset, 0.05- $\mu$ V/ $^{\circ}$ C drift amplifier optimized for low-voltage, single-supply operation with an output swing to within 50 mV of the positive rail. The OPA2333-Q1 uses chopping techniques to provide low initial offset voltage and near-zero drift over time and temperature. Low offset voltage and low drift reduce the offset error in the system, making these devices appropriate for precise dc control. The rail-to-rail output stage of the OPA2333-Q1 makes sure that the output swing of the operational amplifier is able to fully control the gate of the MOSFET devices within the supply rails.

A detailed error analysis, design procedure, and additional measured results are given in the [High-Side V-I Converter reference design](#).

### 8.2.1.3 Application Curve

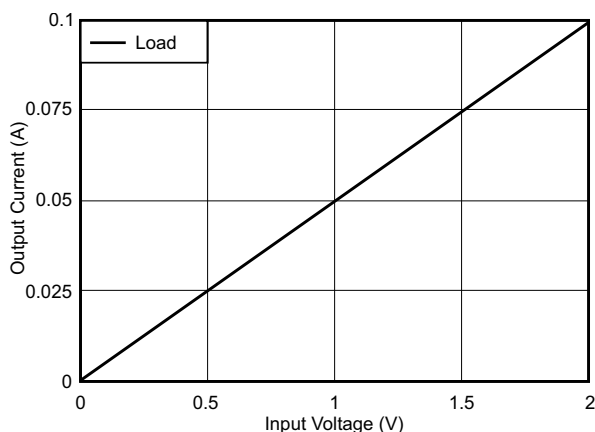

**Figure 21. Measured Transfer Function for High-Side V-I Converter**

## Typical Application (continued)

### 8.2.1.4 Single Op Amp Bridge Amplifier

Figure 22 shows the basic configuration for a bridge amplifier.

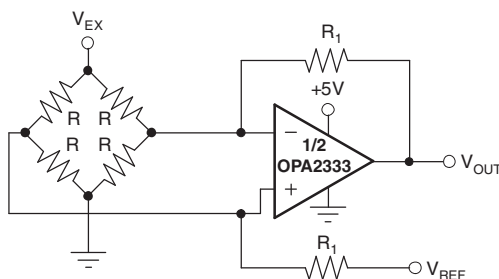
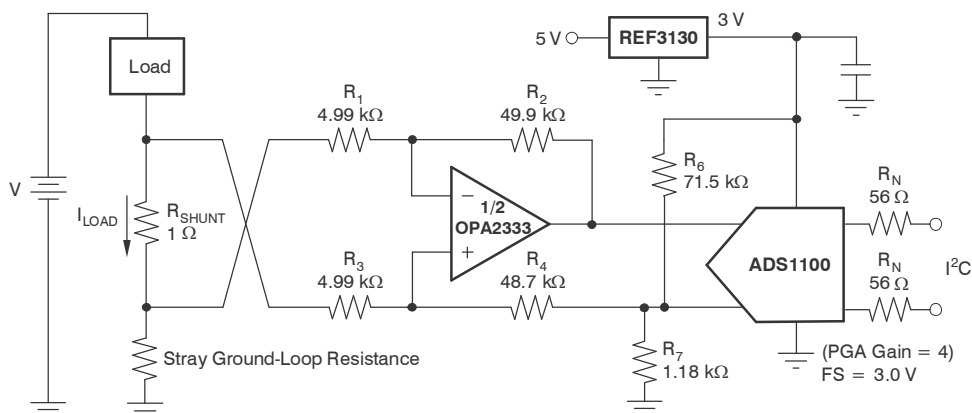

Figure 22. Single Op-Amp Bridge Amplifier

### 8.2.1.5 Low-Side Current Monitor

A low-side current shunt monitor is shown in Figure 23.  $R_N$  are operational resistors used to isolate the ADS1100 from the noise of the digital I<sup>2</sup>C bus. Because the ADS1100 is a 16-bit converter, a precise reference is essential for maximum accuracy. If absolute accuracy is not required, and the 5-V power supply is sufficiently stable, the REF3130 may be omitted.



NOTE: 1% resistors provide adequate common-mode rejection at small ground-loop errors.

Figure 23. Low-Side Current Monitor

**Typical Application (continued)**

**8.2.1.6 High-Side Current Monitor**

Figure 24 shows the use case for a precision single-supply amplifier for a high-side current sensing circuit.

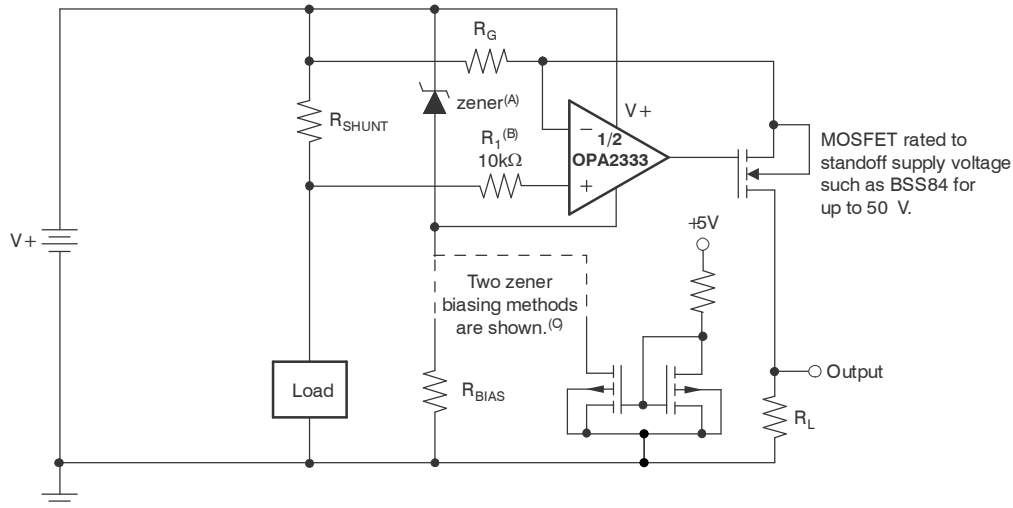

- A. Zener rated for op amp supply capability (that is, 5.1 V for the OPA2333).
- B. Current-limiting resistor.
- C. Choose a Zener biasing resistor or dual NMOSFETs (FDG6301N, NTJD4001N, or Si1034).

**Figure 24. High-Side Current Monitor**

**8.2.1.7 Precision Instrumentation Amplifier**

Figure 25 shows a three op amp implementation for a high-CMRR instrumentation amplifier..

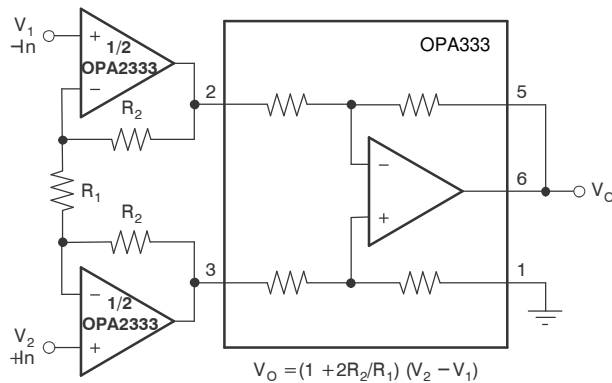

**Figure 25. Precision Instrumentation Amplifier**

## 9 Power Supply Recommendations

The OPA2333-Q1 is specified for operation from 1.8 V to 5.5 V ( $\pm 0.9$  V to  $\pm 2.75$  V); many specifications apply from  $-40^{\circ}\text{C}$  to  $+125^{\circ}\text{C}$ . The *Typical Characteristics* section presents parameters that can exhibit significant variance with regard to operating voltage or temperature.

### CAUTION

Supply voltages greater than 7 V can permanently damage the device (see the *Absolute Maximum Ratings* table).

Place 0.1- $\mu\text{F}$  bypass capacitors near the power-supply pins to reduce coupling errors from noisy or high-impedance power supplies. For more details on bypass capacitor placement, see the *Layout* section.

## 10 Layout

### 10.1 Layout Guidelines

Pay attention to good layout practices. Keep traces short and when possible, use a printed-circuit-board (PCB) ground plane with surface-mount components placed as close to the device pins as possible. Place a 0.1- $\mu\text{F}$  capacitor closely across the supply pins. Apply these guidelines throughout the analog circuit to improve performance and provide benefits, such as reducing the electromagnetic interference (EMI) susceptibility.

Operational amplifiers vary in susceptibility to radio frequency interference (RFI). RFI can generally be identified as a variation in offset voltage or dc signal levels with changes in the interfering RF signal. The OPA2333-Q1 is specifically designed to minimize susceptibility to RFI and demonstrates remarkably low sensitivity compared to previous generation devices. Strong RF fields may still cause varying offset levels.

For lowest offset voltage and precision performance, optimize circuit layout and mechanical conditions. Avoid temperature gradients that create thermoelectric (Seebeck) effects in the thermocouple junctions formed from connecting dissimilar conductors. Cancel these thermally-generated potentials by assuring they are equal on both input terminals. Other layout and design considerations include:

- Use low-thermoelectric-coefficient connections (avoid dissimilar metals).
- Thermally isolate components from power supplies or other heat sources.
- Shield operational amplifier and input circuitry from air currents, such as cooling fans.

Following these guidelines reduces the likelihood of junctions being at different temperatures, which can cause thermoelectric voltages of 0.1  $\mu\text{V}/^{\circ}\text{C}$  or higher, depending on materials used.

### 10.2 Layout Example

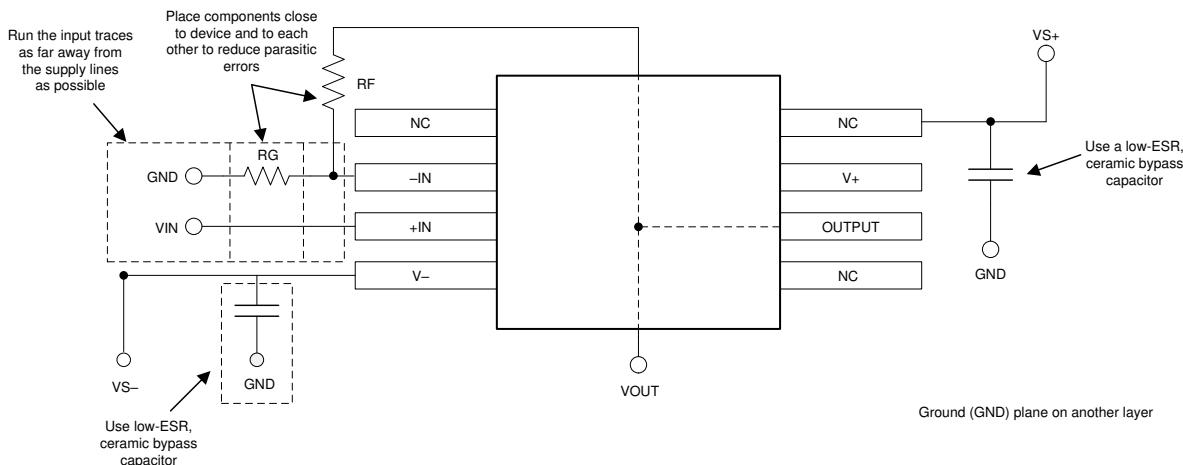

Figure 26. Layout Example

## 11 Device and Documentation Support

### 11.1 Documentation Support

#### 11.1.1 Related Documentation

For related documentation see the following:

- Texas Instruments, [ADS1100 Self-Calibrating, 16-Bit Analog-to-Digital Converter data sheet](#)
- Texas Instruments, [REF31xx 15ppm/°C Maximum, 100-μA, SOT-23 Series Voltage Reference data sheet](#)
- Texas Instruments, [INAx321 microPower, Single-Supply, CMOS Instrumentation Amplifier data sheet](#)
- Texas Instruments, [INA32x Precision, Rail-to-Rail I/O Instrumentation Amplifier data sheet](#)

#### 11.2 Receiving Notification of Documentation Updates

To receive notification of documentation updates, navigate to the device product folder on ti.com. In the upper right corner, click on *Alert me* to register and receive a weekly digest of any product information that has changed. For change details, review the revision history included in any revised document.

#### 11.3 Support Resources

TI E2E™ support forums are an engineer's go-to source for fast, verified answers and design help — straight from the experts. Search existing answers or ask your own question to get the quick design help you need.

Linked content is provided "AS IS" by the respective contributors. They do not constitute TI specifications and do not necessarily reflect TI's views; see TI's [Terms of Use](#).

#### 11.4 Trademarks

E2E is a trademark of Texas Instruments.

All other trademarks are the property of their respective owners.

#### 11.5 Electrostatic Discharge Caution



This integrated circuit can be damaged by ESD. Texas Instruments recommends that all integrated circuits be handled with appropriate precautions. Failure to observe proper handling and installation procedures can cause damage.

ESD damage can range from subtle performance degradation to complete device failure. Precision integrated circuits may be more susceptible to damage because very small parametric changes could cause the device not to meet its published specifications.

#### 11.6 Glossary

[SLYZ022](#) — *TI Glossary*.

This glossary lists and explains terms, acronyms, and definitions.

## 12 Mechanical, Packaging, and Orderable Information

The following pages include mechanical, packaging, and orderable information. This information is the most current data available for the designated devices. This data is subject to change without notice and revision of this document. For browser-based versions of this data sheet, refer to the left-hand navigation.



**PACKAGING INFORMATION**

Orderable Device	Status (1)	Package Type	Package Drawing	Pins	Package Qty	Eco Plan (2)	Lead finish/ Ball material (6)	MSL Peak Temp (3)	Op Temp (°C)	Device Marking (4/5)	Samples
OPA2333AQDGKRQ1	ACTIVE	VSSOP	DGK	8	2500	RoHS & Green	NIPDAU	Level-3-260C-168 HR		OCOQ	<b>Samples</b>
OPA2333AQDRQ1	ACTIVE	SOIC	D	8	2500	RoHS & Green	NIPDAU	Level-1-260C-UNLIM	-40 to 125	02333Q	<b>Samples</b>

(1) The marketing status values are defined as follows:

**ACTIVE:** Product device recommended for new designs.

**LIFEBUY:** TI has announced that the device will be discontinued, and a lifetime-buy period is in effect.

**NRND:** Not recommended for new designs. Device is in production to support existing customers, but TI does not recommend using this part in a new design.

**PREVIEW:** Device has been announced but is not in production. Samples may or may not be available.

**OBSOLETE:** TI has discontinued the production of the device.

(2) **RoHS:** TI defines "RoHS" to mean semiconductor products that are compliant with the current EU RoHS requirements for all 10 RoHS substances, including the requirement that RoHS substance do not exceed 0.1% by weight in homogeneous materials. Where designed to be soldered at high temperatures, "RoHS" products are suitable for use in specified lead-free processes. TI may reference these types of products as "Pb-Free".

**RoHS Exempt:** TI defines "RoHS Exempt" to mean products that contain lead but are compliant with EU RoHS pursuant to a specific EU RoHS exemption.

**Green:** TI defines "Green" to mean the content of Chlorine (Cl) and Bromine (Br) based flame retardants meet JS709B low halogen requirements of <=1000ppm threshold. Antimony trioxide based flame retardants must also meet the <=1000ppm threshold requirement.

(3) MSL, Peak Temp. - The Moisture Sensitivity Level rating according to the JEDEC industry standard classifications, and peak solder temperature.

(4) There may be additional marking, which relates to the logo, the lot trace code information, or the environmental category on the device.

(5) Multiple Device Markings will be inside parentheses. Only one Device Marking contained in parentheses and separated by a "~" will appear on a device. If a line is indented then it is a continuation of the previous line and the two combined represent the entire Device Marking for that device.

(6) Lead finish/Ball material - Orderable Devices may have multiple material finish options. Finish options are separated by a vertical ruled line. Lead finish/Ball material values may wrap to two lines if the finish value exceeds the maximum column width.

**Important Information and Disclaimer:**The information provided on this page represents TI's knowledge and belief as of the date that it is provided. TI bases its knowledge and belief on information provided by third parties, and makes no representation or warranty as to the accuracy of such information. Efforts are underway to better integrate information from third parties. TI has taken and continues to take reasonable steps to provide representative and accurate information but may not have conducted destructive testing or chemical analysis on incoming materials and chemicals. TI and TI suppliers consider certain information to be proprietary, and thus CAS numbers and other limited information may not be available for release.

In no event shall TI's liability arising out of such information exceed the total purchase price of the TI part(s) at issue in this document sold by TI to Customer on an annual basis.

**OTHER QUALIFIED VERSIONS OF OPA2333-Q1 :**

- Catalog: [OPA2333](#)

## NOTE: Qualified Version Definitions:

- Catalog - TI's standard catalog product

**TAPE AND REEL INFORMATION**

**QUADRANT ASSIGNMENTS FOR PIN 1 ORIENTATION IN TAPE**

\*All dimensions are nominal

Device	Package Type	Package Drawing	Pins	SPQ	Reel Diameter (mm)	Reel Width W1 (mm)	A0 (mm)	B0 (mm)	K0 (mm)	P1 (mm)	W (mm)	Pin1 Quadrant
OPA2333AQDGKRQ1	VSSOP	DGK	8	2500	330.0	12.4	5.3	3.3	1.3	8.0	12.0	Q1
OPA2333AQDRQ1	SOIC	D	8	2500	330.0	12.4	6.4	5.2	2.1	8.0	12.0	Q1

**TAPE AND REEL BOX DIMENSIONS**

\*All dimensions are nominal

Device	Package Type	Package Drawing	Pins	SPQ	Length (mm)	Width (mm)	Height (mm)
OPA2333AQDGKRQ1	VSSOP	DGK	8	2500	367.0	367.0	38.0
OPA2333AQDRQ1	SOIC	D	8	2500	356.0	356.0	35.0



D0008A

# PACKAGE OUTLINE

SOIC - 1.75 mm max height

SMALL OUTLINE INTEGRATED CIRCUIT



4214825/C 02/2019

NOTES:

- Linear dimensions are in inches [millimeters]. Dimensions in parenthesis are for reference only. Controlling dimensions are in inches. Dimensioning and tolerancing per ASME Y14.5M.
- This drawing is subject to change without notice.
- This dimension does not include mold flash, protrusions, or gate burrs. Mold flash, protrusions, or gate burrs shall not exceed  $.006$  [0.15] per side.
- This dimension does not include interlead flash.
- Reference JEDEC registration MS-012, variation AA.

# EXAMPLE BOARD LAYOUT

D0008A

SOIC - 1.75 mm max height

SMALL OUTLINE INTEGRATED CIRCUIT



LAND PATTERN EXAMPLE  
 EXPOSED METAL SHOWN  
 SCALE:8X



SOLDER MASK DETAILS

4214825/C 02/2019

NOTES: (continued)

- 6. Publication IPC-7351 may have alternate designs.
- 7. Solder mask tolerances between and around signal pads can vary based on board fabrication site.

# EXAMPLE STENCIL DESIGN

D0008A

SOIC - 1.75 mm max height

SMALL OUTLINE INTEGRATED CIRCUIT



SOLDER PASTE EXAMPLE  
BASED ON .005 INCH [0.125 MM] THICK STENCIL  
SCALE:8X

4214825/C 02/2019

NOTES: (continued)

8. Laser cutting apertures with trapezoidal walls and rounded corners may offer better paste release. IPC-7525 may have alternate design recommendations.
9. Board assembly site may have different recommendations for stencil design.

DGK (S-PDSO-G8)

PLASTIC SMALL-OUTLINE PACKAGE

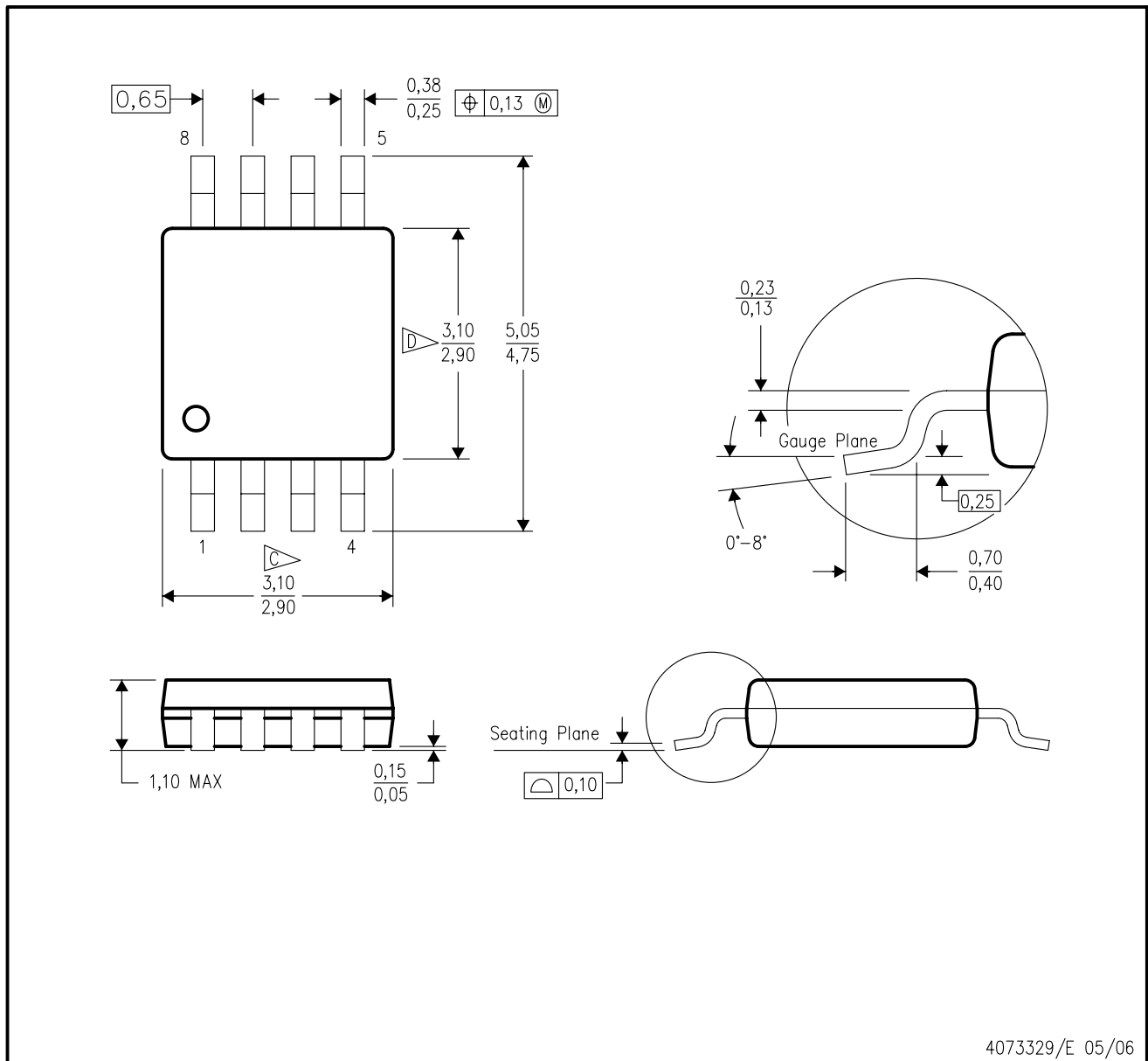

- NOTES:
- A. All linear dimensions are in millimeters.
  - B. This drawing is subject to change without notice.
  - C. Body length does not include mold flash, protrusions, or gate burrs. Mold flash, protrusions, or gate burrs shall not exceed 0.15 per end.
  - D. Body width does not include interlead flash. Interlead flash shall not exceed 0.50 per side.
  - E. Falls within JEDEC MO-187 variation AA, except interlead flash.





- NOTES:
- A. All linear dimensions are in millimeters.
  - B. This drawing is subject to change without notice.
  - C. Publication IPC-7351 is recommended for alternate designs.
  - D. Laser cutting apertures with trapezoidal walls and also rounding corners will offer better paste release. Customers should contact their board assembly site for stencil design recommendations. Refer to IPC-7525 for other stencil recommendations.
  - E. Customers should contact their board fabrication site for solder mask tolerances between and around signal pads.

## IMPORTANT NOTICE AND DISCLAIMER

TI PROVIDES TECHNICAL AND RELIABILITY DATA (INCLUDING DATA SHEETS), DESIGN RESOURCES (INCLUDING REFERENCE DESIGNS), APPLICATION OR OTHER DESIGN ADVICE, WEB TOOLS, SAFETY INFORMATION, AND OTHER RESOURCES "AS IS" AND WITH ALL FAULTS, AND DISCLAIMS ALL WARRANTIES, EXPRESS AND IMPLIED, INCLUDING WITHOUT LIMITATION ANY IMPLIED WARRANTIES OF MERCHANTABILITY, FITNESS FOR A PARTICULAR PURPOSE OR NON-INFRINGEMENT OF THIRD PARTY INTELLECTUAL PROPERTY RIGHTS.

These resources are intended for skilled developers designing with TI products. You are solely responsible for (1) selecting the appropriate TI products for your application, (2) designing, validating and testing your application, and (3) ensuring your application meets applicable standards, and any other safety, security, regulatory or other requirements.

These resources are subject to change without notice. TI grants you permission to use these resources only for development of an application that uses the TI products described in the resource. Other reproduction and display of these resources is prohibited. No license is granted to any other TI intellectual property right or to any third party intellectual property right. TI disclaims responsibility for, and you will fully indemnify TI and its representatives against, any claims, damages, costs, losses, and liabilities arising out of your use of these resources.

TI's products are provided subject to [TI's Terms of Sale](#) or other applicable terms available either on [ti.com](https://www.ti.com) or provided in conjunction with such TI products. TI's provision of these resources does not expand or otherwise alter TI's applicable warranties or warranty disclaimers for TI products.

TI objects to and rejects any additional or different terms you may have proposed.

Mailing Address: Texas Instruments, Post Office Box 655303, Dallas, Texas 75265  
Copyright © 2023, Texas Instruments Incorporated