

CDx4AC245, CDx4ACT245 Octal-Bus Transceiver, Three-State, Non-Inverting

1 Features

- Buffered inputs
- Typical propagation delay
 - 4ns at $V_{CC} = 5V$, $T_A = 25^\circ C$, $C_L = 50pF$
- SCR-latchup-resistant CMOS process and circuit design
- Speed of bipolar FAST™/AS/S with significantly reduced power consumption
- Balanced propagation delays
- AC types feature 1.5V to 5.5V operation and balanced noise immunity at 30% of the supply
- $\pm 24mA$ output drive current
 - Fanout to 15 FAST™ ICs
 - Drives 50 Ω transmission line

2 Description

The 'AC245 and 'ACT245 are octal-bus transceivers that utilize Advanced CMOS Logic technology.

Device Information

PART NUMBER	PACKAGE ⁽¹⁾	PACKAGE SIZE ⁽²⁾	BODY SIZE ⁽³⁾
CD74AC245/ CD74ACT245	N (PDIP, 20)	24.33mm × 9.4mm	24.33mm × 6.35mm
	DW (SOIC, 20)	12.80mm × 10.3mm	12.80mm × 7.50mm
CD54AC245/ CD54ACT245	J (CDIP, 20)	24.2mm × 7.62mm	24.2mm × 6.92mm
CD74ACT245	DB (SSOP, 20)	7.2mm × 7.8mm	7.2mm × 5.3mm

- (1) For more information, see [Section 10](#).
- (2) The package size (length × width) is a nominal value and includes pins, where applicable.
- (3) The body size (length × width) is a nominal value and does not include pins.

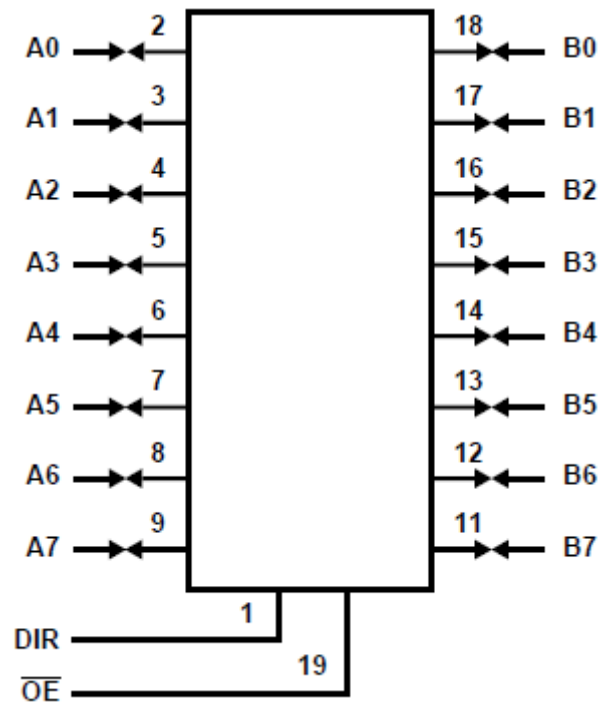

Logic Diagram (Positive Logic)



Table of Contents

1 Features	1	6.3 Device Functional Modes.....	11
2 Description	1	7 Application and Implementation	12
3 Pin Configuration and Functions	3	7.1 Power Supply Recommendations.....	12
4 Specifications	4	7.2 Layout.....	12
4.1 Absolute Maximum Ratings.....	4	8 Device and Documentation Support	13
4.2 Recommended Operating Conditions.....	4	8.1 Documentation Support.....	13
4.3 Thermal Information.....	4	8.2 Receiving Notification of Documentation Updates...	13
4.4 Electrical Characteristics.....	5	8.3 Support Resources.....	13
4.5 Switching Characteristics.....	6	8.4 Trademarks.....	13
4.6 Timing Diagrams	8	8.5 Electrostatic Discharge Caution.....	13
5 Parameter Measurement Information	10	8.6 Glossary.....	13
6 Detailed Description	11	9 Revision History	13
6.1 Overview.....	11	10 Mechanical, Packaging, and Orderable Information	14
6.2 Functional Block Diagram.....	11		

3 Pin Configuration and Functions

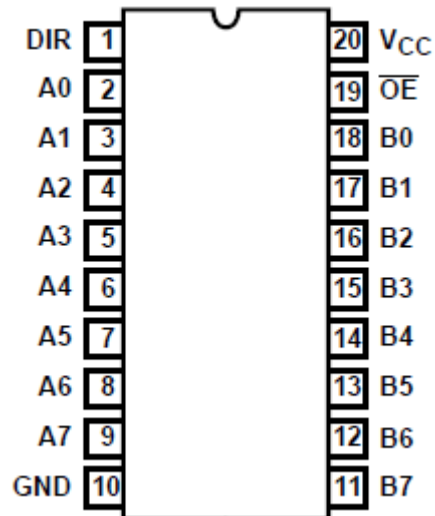

Figure 3-1. CD54AC245, CD54ACT245 (CERDIP), CD74AC245, CD74ACT245 (PDIP, SOIC, SSOP) Top View

Pin Functions

PIN		TYPE ¹	DESCRIPTION
NO.	NAME		
1	DIR	I/O	Direction Pin
2	A0	I/O	A1 Input/Output
3	A1	I/O	A2 Input/Output
4	A2	I/O	A3 Input/Output
5	A3	I/O	A4 Input/Output
6	A4	I/O	A5 Input/Output
7	A5	I/O	A6 Input/Output
8	A6	I/O	A7 Input/Output
9	A7	I/O	A8 Input/Output
10	GND	—	Ground Pin
11	B7	I/O	B7 Input/Output
12	B6	I/O	B6 Input/Output
13	B5	I/O	B5 Input/Output
14	B4	I/O	B4 Input/Output
15	B3	I/O	B3 Input/Output
16	B2	I/O	B2 Input/Output
17	B1	I/O	B1 Input/Output
18	B0	I/O	B0 Input/Output
19	\overline{OE}	I/O	Output Enable
20	V _{CC}	—	Power Pin

(1) Signal Types: I = Input, O = Output, I/O = Input or Output

4 Specifications

4.1 Absolute Maximum Ratings

over operating free-air temperature range (unless otherwise noted)⁽¹⁾

			MIN	MAX	UNIT
V _{CC}	Supply voltage		-0.5	6	V
I _{IK}	Input diode current	V _I < -0.5V or V _I > V _{CC} + 0.5V		± 20	mA
I _{OK}	Output diode current	V _O < -0.5V or V _O > V _{CC} + 0.5V		± 50	mA
I _O	Output source or sink current per output pin	V _O > -0.5V or V _O < V _{CC} + 0.5V		± 50	mA
I _{OK} ⁽²⁾	V _{CC} or ground current	I _{CC} or I _{GND}		± 100	mA
T _{stg}	Storage temperature		-65	150	°C

- (1) Stresses beyond those listed under *Absolute Maximum Ratings* may cause permanent damage to the device. These are stress ratings only, and functional operation of the device at these or any other conditions beyond those indicated under *Recommended Operating Conditions* is not implied. Exposure to absolute-maximum-rated conditions for extended periods may affect device reliability.
- (2) For up to 4 outputs per device, add ±25mA for each additional output.

4.2 Recommended Operating Conditions

over operating free-air temperature range (unless otherwise noted)

		CDx4AC245		CDx4ACT245		UNIT
		MIN	MAX	MIN	MAX	
V _{CC}	Supply voltage ⁽¹⁾	1.5V	5.5V	4.5V	5.5V	V
V _I , V _O	Input or Output Voltage	0V	V _{CC}	0V	V _{CC}	V
dt/dv	Input Rise and Fall Slew Rate	1.5V to 3V		50		ns
		3.6V to 5.5V		20		
		4.5V to 5.5V		10		
T _A	Temperature range	-55	125	-55	125	°C

- (1) Unless otherwise specified, all voltages are referenced to ground.

4.3 Thermal Information

THERMAL METRIC ⁽¹⁾		CDx4AC14/ CDx4ACT14			UNIT
		N (PDIP)	DW (SOIC)	DB (SSOP)	
		20 PINS			
R _{θJA}	Junction-to-ambient thermal resistance	69	98.6	105.4	°C/W

- (1) For more information about traditional and new thermal metrics, see the *Semiconductor and IC Package Thermal Metrics* application report, [SPRA953](#).

4.4 Electrical Characteristics

over recommended operating free-air temperature range (unless otherwise noted)

PARAMETER	TEST CONDITIONS		V_{CC}	$T_A = 25^\circ\text{C}$		$-40^\circ\text{C TO } 85^\circ\text{C}$		$-55^\circ\text{C TO } 125^\circ\text{C}$		UNIT	
	V_I (V)	I_O (mA)		MIN	MAX	MIN	MAX	MIN	MAX		
AC TYPES											
V_{IH}	High-level input voltage		1.5	1.2		1.2		1.2		V	
			3	2.1		2.1		2.1			
			5.5	3.85		3.85		3.85			
V_{IL}	Low-level input voltage	V_{IL}	1.5		0.3		0.3		0.3	V	
			3		0.9		0.9		0.9		
			5.5		1.65		1.65		1.65		
V_{OH}	High-level output voltage	V_{IH} or V_{IL}	-0.05	1.5	1.4		1.4		1.4	V_{VOH}	
			-0.05	3	2.9		2.9		2.9		
			-0.05	4.5	4.4		4.4		4.4		
			-4	3	2.58		2.48		2.4		
			-24	4.5	3.94		3.8		3.7		
			-75	5.5			3.85				
V_{OL}	Low-level output voltage	V_{IH} or V_{IL}	0.05	1.5 V		0.1		0.1	0.1	V	
			0.05	3 V		0.1		0.1	0.1		
			0.05	4.5 V		0.1		0.1	0.1		
			12	3 V		0.36		0.44	0.5		
			24	4.5 V		0.36		0.44	0.5		
			75 ¹	5.5 V				1.65			
I_I	Input leakage current	V_{CC} or GND	5.5			± 0.1		± 1	± 1	μA	
			5.5			± 0.5		± 5	± 10		
			5.5			8		80	160		
			5.5								
			5.5								
			5.5								
ACT TYPES											
V_{IH}	High-level input voltage			4.5 V to 5.5 V	2		2		2	V	
V_{IL}	Low-level input voltage			4.5 V to 5.5 V		0.8		0.8		V	
V_{OH}	High-level output voltage	V_{IH} or V_{IL}	-0.05	4.5 V	4.4		4.4		4.4	0.8	V
			-24	4.5 V	3.94		3.8		3.7		
			-75 ¹	5.5 V			3.85				
			-50	5.5 V					3.85		

over recommended operating free-air temperature range (unless otherwise noted)

PARAMETER	TEST CONDITIONS		V _{CC}	T _A = 25°C		-40°C TO 85°C		-55°C TO 125°C		UNIT
	V _I (V)	I _O (mA)		MIN	MAX	MIN	MAX	MIN	MAX	
V _{OL} Low-level output voltage	V _{IH} or V _{IL}	0.05	4.5	0.1		0.1		0.1		V
		24	4.5	0.36		0.44		0.5		
		75 ¹	5.5			1.65				
		50 ¹	5.5					1.65		
									V	
I _I Input leakage current	V _{CC} or GND		5.5 V	± 0.1		± 1		± 1		µA
I _{OZ} Three-state or leakage current	V _{IH} or V _{IL} , V _O = V _{CC} or GND		5.5 V	± 0.5		± 5		± 10		µA
I _{CC} Quiescent supply current MSI	V _{CC} or GND	0	5.5 V	8		80		160		µA
Δ I _{CC} Additional supply current per input pin TTL inputs high 1 unit load	V _{CC} -2.1		4.5 to 5.5	2.4		2.8		3		mA

1. Test one output at a time for a 1-second maximum duration. Measurement is made by forcing current and measuring voltage to minimize power dissipation. Test verifies a minimum 50Ω transmission-line-drive capability at 85°C, 75Ω at 125°C.

4.5 Switching Characteristics

Input t_r, t_f = 3ns, C_L = 50pF (Worst Case). Over recommended operating free-air temperature range (unless otherwise noted) (see [Load Circuit and Voltage Waveforms](#))

PARAMETER	V _{CC} (V)	-40°C TO 85°C			-55°C TO 125°C			UNIT
		MIN	TYP	MAX	MIN	TYP	MAX	
AC TYPES								
t _{PLH} , t _{PHL} Propagation delay, data to output	1.5			96			106	ns
	3.3	3.2		10.8	3		11.9	
	5	2.2		7.7	2.1		8.5	
t _{PLZ} , t _{PHZ} Propagation delay, output disable to output	1.5			159			175	ns
	3.3	4.7		15.9	4.4		17.5	
	5	3.7		12.7	3.5		14	
t _{PZL} , t _{PZH} Propagation delay, output enable to output	1.5			159			175	ns
	3.3	5.6		19	5.3		21	
	5	3.7		12.7	3.5			
V _{OHV} Minimum (Valley) V _{OH} During switching of other outputs (output under test not switching)	5	4 at 25°C			4 at 25°C			V

Input t_r , $t_f = 3\text{ns}$, $C_L = 50\text{pF}$ (Worst Case). Over recommended operating free-air temperature range (unless otherwise noted) (see [Load Circuit and Voltage Waveforms](#))

PARAMETER		V_{CC} (V)	-40°C TO 85°C			-55°C TO 125°C			UNIT
			MIN	TYP	MAX	MIN	TYP	MAX	
V_{OLP}	Maximum (Peak) V_{OL} During switching of other outputs (output under test not switching)	5	1 at 25°C			1 at 25°C			V
C_O	Three-state output capacitance		15			15			pF
C_I	Input capacitance		10			10			pF
C_{PD}	Power dissipation capacitance		57			57			pF
ACT TYPES									
t_{PLH} , t_{PHL}	Propagation delay, data to output	5	2.7		9.1	2.5		10	ns
t_{PLZ} , t_{PHZ}	Propagation delay, output disable to output	5	3.7		12.7	3.5		14	ns
t_{PZL} , t_{PZH}	Propagation delay, output enable to output	5	3.8		13.1	3.6		14.4	ns
V_{OHV}	Minimum (Valley) V_{OH} During switching of other outputs (output under test not switching)	5	4 at 25°C			4 at 25°C			V
V_{OLP}	Maximum (Peak) V_{OL} During switching of other outputs (output under test not switching)	5	1 at 25°C			1 at 25°C			V
C_O	Three-state output capacitance		15			15			pF
C_I	Input capacitance		10			10			pF
C_{PD}	Power dissipation capacitance		57			57			pF

- Limits tested 100%
- 3.3V Min is at 3.6V, Max is at 3V
- 5V Min is at 5.5V, Max is at 4.5V
- CPD is used to determine the dynamic power consumption per channel
 - AC: $PD = V_{CC}^2 f_i (CPD + CL)$
 - ACT: $PD = V_{CC}^2 f_i (CPD + CL) + V_{CC} \Delta ICC$ where f_i = input frequency, CL = output load capacitance, V_{CC} = supply voltage

4.6 Timing Diagrams

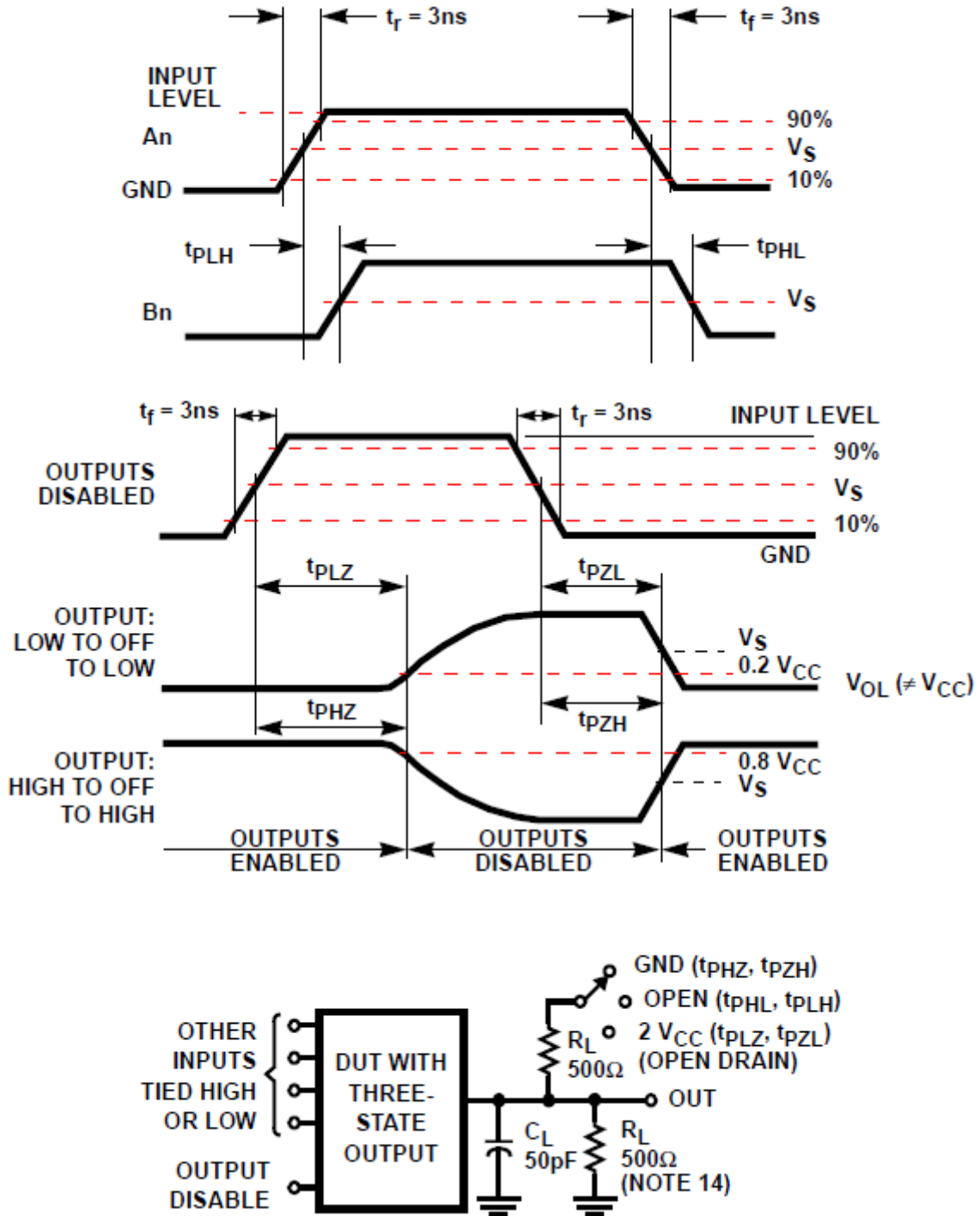

Figure 4-1. THREE-STATE PROPAGATION DELAY TIMES AND TEST CIRCUIT

Figure 4-1. SIMULTANEOUS SWITCHING TRANSIENT WAVEFORMS

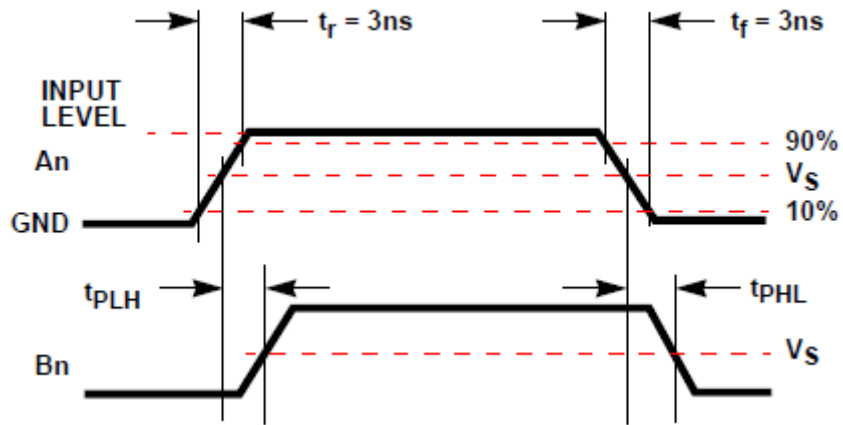
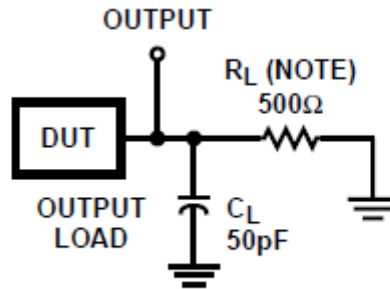

Figure 4-3. PROPAGATION DELAY TIMES



NOTE: For AC Series Only: When $V_{CC} = 1.5\text{V}$, $R_L = 1\text{k}\Omega$.

Table 4-1.

	AC	ACT
Input Level	V_{CC}	3V
Input Switching Voltage, V_S	$0.5 V_{CC}$	1.5V
Output Switching Voltage, V_S	$0.5 V_{CC}$	$0.5 V_{CC}$

Figure 4-4. PROPAGATION DELAY TIMES

5 Parameter Measurement Information

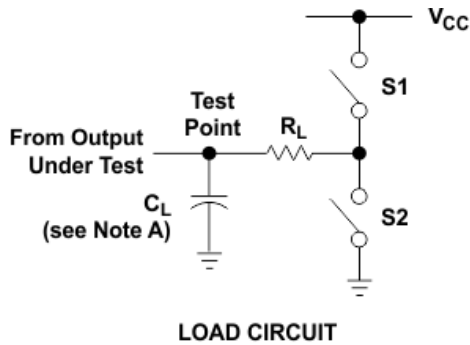

PARAMETER		R_L	C_L	S1	S2
t_{en}	t_{pZH}	1 k Ω	50 pF or 150 pF	Open	Closed
	t_{pZL}			Closed	Open
t_{dis}	t_{pHZ}	1 k Ω	50 pF	Open	Closed
	t_{pLZ}			Closed	Open
t_{pd} or t_t		--	50 pF or 150 pF	Open	Open

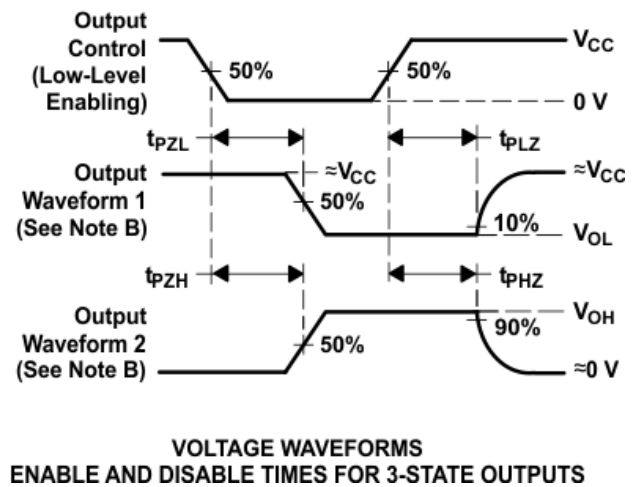
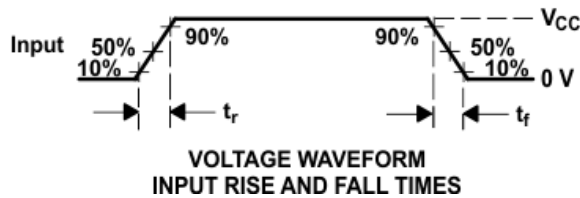
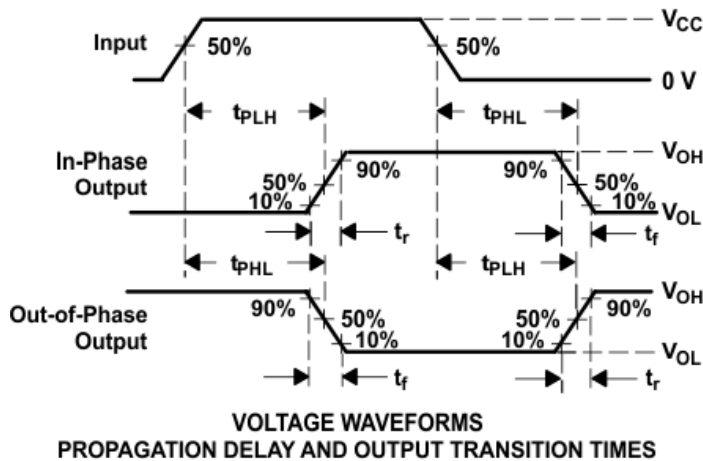

6 Detailed Description

6.1 Overview

The 'AC245 and 'ACT245 are non-inverting three-state bidirectional transceiver-buffers intended for two-way transmission from “A” bus to “B” bus or “B” bus to “A”. The logic level present on the direction input (DIR) determines the data direction. When the output enable input (\overline{OE}) is HIGH, the outputs are in the high-impedance state.

6.2 Functional Block Diagram

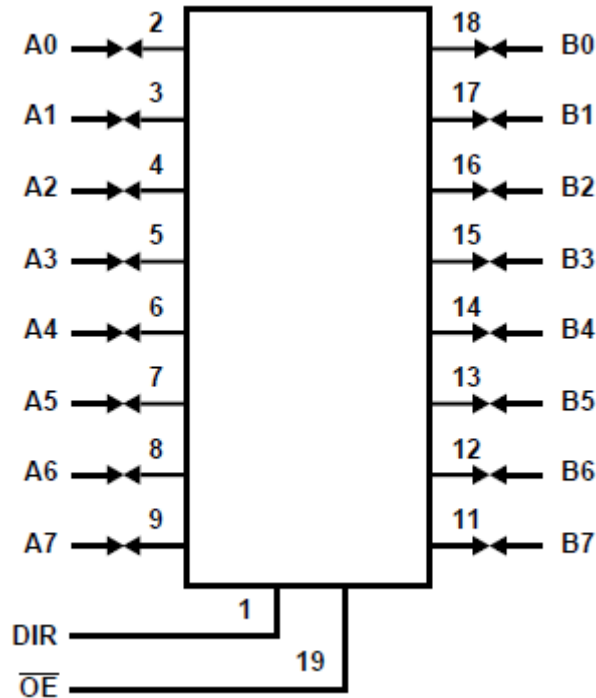

Logic Diagram (Positive Logic)

6.3 Device Functional Modes

[Function Table](#) lists the function modes of the CDx4AC245, CDx4ACT245.

Table 6-1. Function Table

INPUTS ⁽¹⁾		OPERATION
\overline{OE}	DIR	
L	L	B data to A bus
L	H	A data to B bus
H	X	Isolation

(1) H = High Voltage Level, L = Low Voltage Level, X = Don't Care

7 Application and Implementation

Note

Information in the following applications sections is not part of the TI component specification, and TI does not warrant its accuracy or completeness. TI's customers are responsible for determining suitability of components for their purposes, as well as validating and testing their design implementation to confirm system functionality.

7.1 Power Supply Recommendations

The power supply can be any voltage between the MIN and MAX supply voltage rating located in the [Section 4.2](#).

Each V_{CC} pin should have a good bypass capacitor to prevent power disturbance. For devices with a single supply, 0.1 μF is recommended; if there are multiple V_{CC} pins, then 0.01 μF or 0.022 μF is recommended for each power pin. It is acceptable to parallel multiple bypass caps to reject different frequencies of noise. A 0.1 μF and a 1 μF are commonly used in parallel. The bypass capacitor should be installed as close to the power pin as possible for best results.

7.2 Layout

7.2.1 Layout Guidelines

When using multiple-bit logic devices, inputs should never float.

In many cases, functions or parts of functions of digital logic devices are unused, for example, when only two inputs of a triple-input AND gate are used or only 3 of the 4 buffer gates are used. Such input pins should not be left unconnected because the undefined voltages at the outside connections result in undefined operational states. [Section 7.2.2](#) specifies the rules that must be observed under all circumstances. All unused inputs of digital logic devices must be connected to a high or low bias to prevent them from floating. The logic level that should be applied to any particular unused input depends on the function of the device. Generally they will be tied to GND or V_{CC} , whichever makes more sense or is more convenient. It is generally acceptable to float outputs, unless the part is a transceiver. If the transceiver has an output enable pin, it will disable the output section of the part when asserted. This will not disable the input section of the IOs, so they cannot float when disabled.

7.2.2 Layout Example

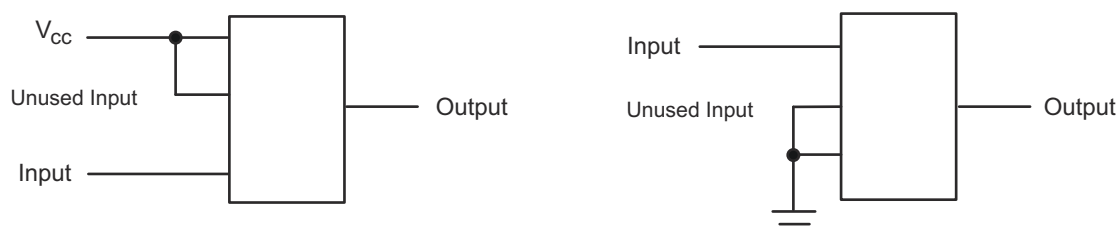

Figure 7-1. Layout Diagram

8 Device and Documentation Support

8.1 Documentation Support

8.1.1 Related Links

The table below lists quick access links. Categories include technical documents, support and community resources, tools and software, and quick access to sample or buy.

Table 8-1. Related Links

PARTS	PRODUCT FOLDER	SAMPLE & BUY	TECHNICAL DOCUMENTS	TOOLS & SOFTWARE	SUPPORT & COMMUNITY
CD54AC245	Click here	Click here	Click here	Click here	Click here
CD74AC245	Click here	Click here	Click here	Click here	Click here
CD54ACT245	Click here	Click here	Click here	Click here	Click here
CD74ACT245	Click here	Click here	Click here	Click here	Click here

8.2 Receiving Notification of Documentation Updates

To receive notification of documentation updates, navigate to the device product folder on [ti.com](#). Click on *Notifications* to register and receive a weekly digest of any product information that has changed. For change details, review the revision history included in any revised document.

8.3 Support Resources

[TI E2E™ support forums](#) are an engineer's go-to source for fast, verified answers and design help — straight from the experts. Search existing answers or ask your own question to get the quick design help you need.

Linked content is provided "AS IS" by the respective contributors. They do not constitute TI specifications and do not necessarily reflect TI's views; see TI's [Terms of Use](#).

8.4 Trademarks

TI E2E™ is a trademark of Texas Instruments.
All trademarks are the property of their respective owners.

8.5 Electrostatic Discharge Caution



This integrated circuit can be damaged by ESD. Texas Instruments recommends that all integrated circuits be handled with appropriate precautions. Failure to observe proper handling and installation procedures can cause damage.

ESD damage can range from subtle performance degradation to complete device failure. Precision integrated circuits may be more susceptible to damage because very small parametric changes could cause the device not to meet its published specifications.

8.6 Glossary

[TI Glossary](#) This glossary lists and explains terms, acronyms, and definitions.

9 Revision History

NOTE: Page numbers for previous revisions may differ from page numbers in the current version.

Changes from Revision C (May 2023) to Revision D (April 2024) Page

- Added *Application and Implementation* section, *Device and Documentation Support* section, and package size to *Device Information* table..... **1**
- Updated RθJA values: DW = 58 to 98.6, DB = 70 to 105.4, all values in °C/W **4**

Changes from Revision B (April 2002) to Revision C (May 2023) Page

- Added *Package Information* table, *Pin Functions* table, and *Thermal Information* table..... **1**

10 Mechanical, Packaging, and Orderable Information

The following pages include mechanical, packaging, and orderable information. This information is the most current data available for the designated devices. This data is subject to change without notice and revision of this document. For browser-based versions of this data sheet, refer to the left-hand navigation.

PACKAGING INFORMATION

Orderable part number	Status (1)	Material type (2)	Package Pins	Package qty Carrier	RoHS (3)	Lead finish/ Ball material (4)	MSL rating/ Peak reflow (5)	Op temp (°C)	Part marking (6)
CD54AC245F3A	Active	Production	CDIP (J) 20	20 TUBE	No	SNPB	N/A for Pkg Type	-55 to 125	CD54AC245F3A
CD54AC245F3A.A	Active	Production	CDIP (J) 20	20 TUBE	No	SNPB	N/A for Pkg Type	-55 to 125	CD54AC245F3A
CD54ACT245F3A	Active	Production	CDIP (J) 20	20 TUBE	No	SNPB	N/A for Pkg Type	-55 to 125	CD54ACT245F3A
CD54ACT245F3A.A	Active	Production	CDIP (J) 20	20 TUBE	No	SNPB	N/A for Pkg Type	-55 to 125	CD54ACT245F3A
CD74AC245E	Active	Production	PDIP (N) 20	20 TUBE	Yes	NIPDAU	N/A for Pkg Type	-55 to 125	CD74AC245E
CD74AC245E.A	Active	Production	PDIP (N) 20	20 TUBE	Yes	NIPDAU	N/A for Pkg Type	-55 to 125	CD74AC245E
CD74AC245EE4	Active	Production	PDIP (N) 20	20 TUBE	Yes	NIPDAU	N/A for Pkg Type	-55 to 125	CD74AC245E
CD74AC245M	Obsolete	Production	SOIC (DW) 20	-	-	Call TI	Call TI	-55 to 125	AC245M
CD74AC245M96	Active	Production	SOIC (DW) 20	2000 LARGE T&R	Yes	NIPDAU	Level-1-260C-UNLIM	-55 to 125	AC245M
CD74AC245M96.A	Active	Production	SOIC (DW) 20	2000 LARGE T&R	Yes	NIPDAU	Level-1-260C-UNLIM	-55 to 125	AC245M
CD74ACT245E	NRND	Production	PDIP (N) 20	20 TUBE	Yes	NIPDAU	N/A for Pkg Type	-55 to 125	CD74ACT245E
CD74ACT245E.A	NRND	Production	PDIP (N) 20	20 TUBE	Yes	NIPDAU	N/A for Pkg Type	-55 to 125	CD74ACT245E
CD74ACT245EE4	NRND	Production	PDIP (N) 20	20 TUBE	Yes	NIPDAU	N/A for Pkg Type	-55 to 125	CD74ACT245E
CD74ACT245M	Obsolete	Production	SOIC (DW) 20	-	-	Call TI	Call TI	-55 to 125	ACT245M
CD74ACT245M96	Active	Production	SOIC (DW) 20	2000 LARGE T&R	Yes	NIPDAU	Level-1-260C-UNLIM	-55 to 125	(ACT245, ACT245M)
CD74ACT245M96.A	Active	Production	SOIC (DW) 20	2000 LARGE T&R	Yes	NIPDAU	Level-1-260C-UNLIM	-55 to 125	(ACT245, ACT245M)
CD74ACT245SM96	Active	Production	SSOP (DB) 20	2000 LARGE T&R	Yes	NIPDAU	Level-1-260C-UNLIM	-55 to 125	(ACT245, ACT245SM)
CD74ACT245SM96.A	Active	Production	SSOP (DB) 20	2000 LARGE T&R	Yes	NIPDAU	Level-1-260C-UNLIM	-55 to 125	(ACT245, ACT245SM)

(1) **Status:** For more details on status, see our [product life cycle](#).

(2) **Material type:** When designated, preproduction parts are prototypes/experimental devices, and are not yet approved or released for full production. Testing and final process, including without limitation quality assurance, reliability performance testing, and/or process qualification, may not yet be complete, and this item is subject to further changes or possible discontinuation. If available for ordering, purchases will be subject to an additional waiver at checkout, and are intended for early internal evaluation purposes only. These items are sold without warranties of any kind.

(3) **RoHS values:** Yes, No, RoHS Exempt. See the [TI RoHS Statement](#) for additional information and value definition.

(4) **Lead finish/Ball material:** Parts may have multiple material finish options. Finish options are separated by a vertical ruled line. Lead finish/Ball material values may wrap to two lines if the finish value exceeds the maximum column width.

⁽⁵⁾ **MSL rating/Peak reflow:** The moisture sensitivity level ratings and peak solder (reflow) temperatures. In the event that a part has multiple moisture sensitivity ratings, only the lowest level per JEDEC standards is shown. Refer to the shipping label for the actual reflow temperature that will be used to mount the part to the printed circuit board.

⁽⁶⁾ **Part marking:** There may be an additional marking, which relates to the logo, the lot trace code information, or the environmental category of the part.

Multiple part markings will be inside parentheses. Only one part marking contained in parentheses and separated by a "~" will appear on a part. If a line is indented then it is a continuation of the previous line and the two combined represent the entire part marking for that device.

Important Information and Disclaimer: The information provided on this page represents TI's knowledge and belief as of the date that it is provided. TI bases its knowledge and belief on information provided by third parties, and makes no representation or warranty as to the accuracy of such information. Efforts are underway to better integrate information from third parties. TI has taken and continues to take reasonable steps to provide representative and accurate information but may not have conducted destructive testing or chemical analysis on incoming materials and chemicals. TI and TI suppliers consider certain information to be proprietary, and thus CAS numbers and other limited information may not be available for release.

In no event shall TI's liability arising out of such information exceed the total purchase price of the TI part(s) at issue in this document sold by TI to Customer on an annual basis.

OTHER QUALIFIED VERSIONS OF CD54AC245, CD54ACT245, CD74AC245, CD74ACT245 :

- Catalog : [CD74AC245](#), [CD74ACT245](#)
- Military : [CD54AC245](#), [CD54ACT245](#)

NOTE: Qualified Version Definitions:

- Catalog - TI's standard catalog product
- Military - QML certified for Military and Defense Applications

TAPE AND REEL INFORMATION

QUADRANT ASSIGNMENTS FOR PIN 1 ORIENTATION IN TAPE

*All dimensions are nominal

Device	Package Type	Package Drawing	Pins	SPQ	Reel Diameter (mm)	Reel Width W1 (mm)	A0 (mm)	B0 (mm)	K0 (mm)	P1 (mm)	W (mm)	Pin1 Quadrant
CD74AC245M96	SOIC	DW	20	2000	330.0	24.4	10.8	13.3	2.7	12.0	24.0	Q1
CD74ACT245M96	SOIC	DW	20	2000	330.0	24.4	10.9	13.3	2.7	12.0	24.0	Q1
CD74ACT245M96	SOIC	DW	20	2000	330.0	24.4	10.8	13.3	2.7	12.0	24.0	Q1
CD74ACT245SM96	SSOP	DB	20	2000	330.0	16.4	8.2	7.5	2.5	12.0	16.0	Q1

TAPE AND REEL BOX DIMENSIONS

*All dimensions are nominal

Device	Package Type	Package Drawing	Pins	SPQ	Length (mm)	Width (mm)	Height (mm)
CD74AC245M96	SOIC	DW	20	2000	356.0	356.0	45.0
CD74ACT245M96	SOIC	DW	20	2000	356.0	356.0	45.0
CD74ACT245M96	SOIC	DW	20	2000	356.0	356.0	45.0
CD74ACT245SM96	SSOP	DB	20	2000	353.0	353.0	32.0

TUBE

*All dimensions are nominal

Device	Package Name	Package Type	Pins	SPQ	L (mm)	W (mm)	T (μm)	B (mm)
CD74AC245E	N	PDIP	20	20	506	13.97	11230	4.32
CD74AC245E.A	N	PDIP	20	20	506	13.97	11230	4.32
CD74AC245EE4	N	PDIP	20	20	506	13.97	11230	4.32
CD74ACT245E	N	PDIP	20	20	506	13.97	11230	4.32
CD74ACT245E.A	N	PDIP	20	20	506	13.97	11230	4.32
CD74ACT245EE4	N	PDIP	20	20	506	13.97	11230	4.32

DB0020A



PACKAGE OUTLINE

SSOP - 2 mm max height

SMALL OUTLINE PACKAGE



4214851/B 08/2019

EXAMPLE BOARD LAYOUT

DB0020A

SSOP - 2 mm max height

SMALL OUTLINE PACKAGE



LAND PATTERN EXAMPLE
EXPOSED METAL SHOWN
SCALE: 10X



4214851/B 08/2019

NOTES: (continued)

- 6. Publication IPC-7351 may have alternate designs.
- 7. Solder mask tolerances between and around signal pads can vary based on board fabrication site.

EXAMPLE STENCIL DESIGN

DB0020A

SSOP - 2 mm max height

SMALL OUTLINE PACKAGE



SOLDER PASTE EXAMPLE
BASED ON 0.125 mm THICK STENCIL
SCALE: 10X

4214851/B 08/2019

NOTES: (continued)

8. Laser cutting apertures with trapezoidal walls and rounded corners may offer better paste release. IPC-7525 may have alternate design recommendations.
9. Board assembly site may have different recommendations for stencil design.

J (R-GDIP-T**)

14 LEADS SHOWN

CERAMIC DUAL IN-LINE PACKAGE



DIM \ PINS **	14	16	18	20
A	0.300 (7,62) BSC	0.300 (7,62) BSC	0.300 (7,62) BSC	0.300 (7,62) BSC
B MAX	0.785 (19,94)	.840 (21,34)	0.960 (24,38)	1.060 (26,92)
B MIN	—	—	—	—
C MAX	0.300 (7,62)	0.300 (7,62)	0.310 (7,87)	0.300 (7,62)
C MIN	0.245 (6,22)	0.245 (6,22)	0.220 (5,59)	0.245 (6,22)



4040083/F 03/03

- NOTES:
- All linear dimensions are in inches (millimeters).
 - This drawing is subject to change without notice.
 - This package is hermetically sealed with a ceramic lid using glass frit.
 - Index point is provided on cap for terminal identification only on press ceramic glass frit seal only.
 - Falls within MIL STD 1835 GDIP1-T14, GDIP1-T16, GDIP1-T18 and GDIP1-T20.

N (R-PDIP-T**)

PLASTIC DUAL-IN-LINE PACKAGE

16 PINS SHOWN



4040049/E 12/2002

- NOTES:
- A. All linear dimensions are in inches (millimeters).
 - B. This drawing is subject to change without notice.
 - (C) Falls within JEDEC MS-001, except 18 and 20 pin minimum body length (Dim A).
 - (D) The 20 pin end lead shoulder width is a vendor option, either half or full width.

DW0020A



PACKAGE OUTLINE

SOIC - 2.65 mm max height

SOIC



NOTES:

1. All linear dimensions are in millimeters. Dimensions in parenthesis are for reference only. Dimensioning and tolerancing per ASME Y14.5M.
2. This drawing is subject to change without notice.
3. This dimension does not include mold flash, protrusions, or gate burrs. Mold flash, protrusions, or gate burrs shall not exceed 0.15 mm per side.
4. This dimension does not include interlead flash. Interlead flash shall not exceed 0.43 mm per side.
5. Reference JEDEC registration MS-013.

EXAMPLE BOARD LAYOUT

DW0020A

SOIC - 2.65 mm max height

SOIC



LAND PATTERN EXAMPLE
SCALE:6X



SOLDER MASK DETAILS

4220724/A 05/2016

NOTES: (continued)

- 6. Publication IPC-7351 may have alternate designs.
- 7. Solder mask tolerances between and around signal pads can vary based on board fabrication site.

EXAMPLE STENCIL DESIGN

DW0020A

SOIC - 2.65 mm max height

SOIC



SOLDER PASTE EXAMPLE
BASED ON 0.125 mm THICK STENCIL
SCALE:6X

4220724/A 05/2016

NOTES: (continued)

8. Laser cutting apertures with trapezoidal walls and rounded corners may offer better paste release. IPC-7525 may have alternate design recommendations.
9. Board assembly site may have different recommendations for stencil design.

IMPORTANT NOTICE AND DISCLAIMER

TI PROVIDES TECHNICAL AND RELIABILITY DATA (INCLUDING DATASHEETS), DESIGN RESOURCES (INCLUDING REFERENCE DESIGNS), APPLICATION OR OTHER DESIGN ADVICE, WEB TOOLS, SAFETY INFORMATION, AND OTHER RESOURCES "AS IS" AND WITH ALL FAULTS, AND DISCLAIMS ALL WARRANTIES, EXPRESS AND IMPLIED, INCLUDING WITHOUT LIMITATION ANY IMPLIED WARRANTIES OF MERCHANTABILITY, FITNESS FOR A PARTICULAR PURPOSE OR NON-INFRINGEMENT OF THIRD PARTY INTELLECTUAL PROPERTY RIGHTS.

These resources are intended for skilled developers designing with TI products. You are solely responsible for (1) selecting the appropriate TI products for your application, (2) designing, validating and testing your application, and (3) ensuring your application meets applicable standards, and any other safety, security, regulatory or other requirements.

These resources are subject to change without notice. TI grants you permission to use these resources only for development of an application that uses the TI products described in the resource. Other reproduction and display of these resources is prohibited. No license is granted to any other TI intellectual property right or to any third party intellectual property right. TI disclaims responsibility for, and you fully indemnify TI and its representatives against any claims, damages, costs, losses, and liabilities arising out of your use of these resources.

TI's products are provided subject to [TI's Terms of Sale](#), [TI's General Quality Guidelines](#), or other applicable terms available either on ti.com or provided in conjunction with such TI products. TI's provision of these resources does not expand or otherwise alter TI's applicable warranties or warranty disclaimers for TI products. Unless TI explicitly designates a product as custom or customer-specified, TI products are standard, catalog, general purpose devices.

TI objects to and rejects any additional or different terms you may propose.

Copyright © 2026, Texas Instruments Incorporated

Last updated 10/2025