

# ADS1x2C14 Low-power, 16- and 24-Bit, 8-Channel, 64kSPS, Delta-Sigma ADC With PGA, Voltage Reference, and I<sup>2</sup>C Interface

## 1 Features

- Low power consumption (as low as 57µA)
- Wide supply voltage range:
  - Analog: 1.74V to 3.6V
  - Digital: 1.65V to 3.6V
- Programmable gain: 0.5 to 256
- Programmable data rate (up to 64kSPS) and speed mode to trade power consumption and noise performance
- Simultaneous 50Hz and 60Hz rejection at 20 or 25SPS with single-cycle settling digital filter
- Analog multiplexer with 8 independently selectable inputs
- Dual-matched programmable current sources
- Internal programmable voltage reference: 1.25V or 2.5V with 25ppm/°C (max) drift
- Internal 1% (max) accurate oscillator
- Internal temperature sensor
- Four general-purpose I/Os (push-pull or open-drain output)
- I<sup>2</sup>C-compatible interface with optional CRC
- Supported I<sup>2</sup>C bus speeds: Sm, Fm, Fm+
- Eight pin-programmable I<sup>2</sup>C addresses

## 2 Applications

- Field transmitters:
  - Temperature, pressure, strain, flow
- PLC and DCS analog input modules
- Temperature controllers
- Patient monitoring systems:
  - Body temperature, blood pressure

## 3 Description

The ADS1x2C14 are precision, low-power, 16- and 24-bit, analog-to-digital converters (ADCs) that offer many integrated features to reduce system cost and component count in the most common sensor measurement applications. The devices feature eight analog inputs through a flexible input multiplexer (MUX), a low-noise, programmable gain amplifier (PGA), a programmable low-drift voltage reference, two programmable excitation current sources, an oscillator, and a temperature sensor.

Four speed modes, with programmable output data rates from 20SPS up to 64kSPS, allow to optimize power consumption and noise performance for each application. At output data rates of 20SPS and 25SPS, the integrated digital filter offers simultaneous 50Hz and 60Hz line-cycle rejection with single-cycle settling.

### Package Information

PART NUMBER	PACKAGE <sup>(1)</sup>	PACKAGE SIZE <sup>(2)</sup>
ADS1x2C14	RTE (WQFN, 16)	3.00mm × 3.00mm
	YBH (DSBGA, 16)	1.87mm × 1.97mm

- (1) For all available packages, see the orderable addendum at the end of the data sheet.
- (2) The package size (length × width) is a nominal value.

Table 3-1. Device Information

PART NUMBER	RESOLUTION	ANALOG INPUTS
ADS112C14	16 Bit	8
ADS122C14	24 Bit	8

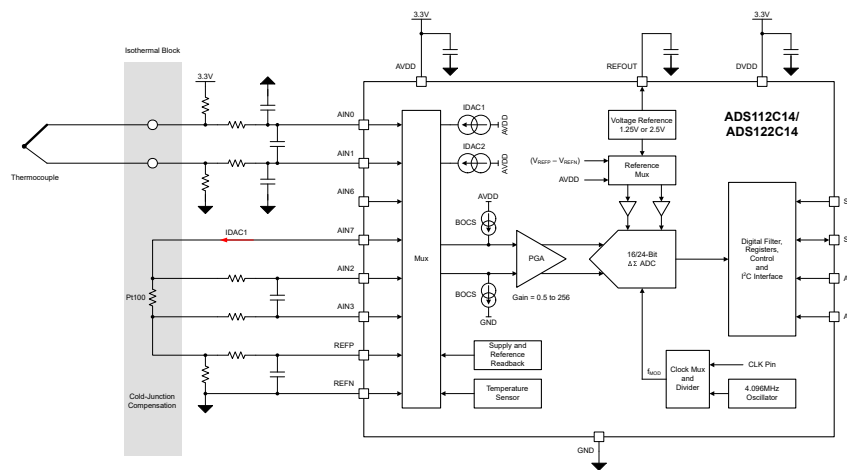

**K-Type Thermocouple Measurement  
With Cold-Junction Compensation Using a 2-wire Pt100 RTD**



## Table of Contents

<b>1 Features</b> .....	1	7.5.7 I <sup>3</sup> C Compatibility.....	37
<b>2 Applications</b> .....	1	7.5.8 Commands.....	38
<b>3 Description</b> .....	1	7.5.9 STATUS Header.....	40
<b>4 Pin Configuration and Functions</b> .....	3	7.5.10 I <sup>2</sup> C CRC.....	40
<b>5 Specifications</b> .....	4	7.5.11 Register Map CRC.....	41
5.1 Absolute Maximum Ratings.....	4	7.5.12 Data Ready (DRDY) Pin.....	42
5.2 ESD Ratings.....	4	7.5.13 Monitoring for New Conversion Data.....	43
5.3 Recommended Operating Conditions.....	5	7.5.14 Conversion Data Format.....	44
5.4 Thermal Information.....	5	<b>8 Registers</b> .....	45
5.5 Electrical Characteristics.....	6	<b>9 Application and Implementation</b> .....	62
5.6 I <sup>2</sup> C Timing Requirements.....	11	9.1 Application Information.....	62
5.7 I <sup>2</sup> C Switching Characteristics.....	12	9.1.1 Serial Interface Connections.....	62
5.8 Timing Diagrams.....	12	9.1.2 Connecting Multiple Devices on the Same I <sup>2</sup> C Bus.....	63
5.9 Typical Characteristics.....	13	9.1.3 Unused Inputs and Outputs.....	63
<b>6 Parameter Measurement Information</b> .....	14	9.1.4 Device Initialization.....	64
6.1 Noise Performance.....	14	9.2 Typical Applications.....	65
<b>7 Detailed Description</b> .....	18	9.2.1 Software-Configurable RTD Measurement Input.....	65
7.1 Overview.....	18	9.2.2 Thermocouple Measurement With Cold-Junction Compensation Using a 2-wire RTD.....	70
7.2 Functional Block Diagram.....	19	9.2.3 Resistive Bridge Sensor Measurement With Temperature Compensation.....	71
7.3 Feature Description.....	19	9.3 Power Supply Recommendations.....	73
7.3.1 Analog Inputs and Multiplexer.....	19	9.3.1 Power Supplies.....	73
7.3.2 Programmable Gain Amplifier (PGA).....	21	9.3.2 Power-Supply Sequencing.....	73
7.3.3 Voltage Reference.....	22	9.3.3 Power-Supply Decoupling.....	73
7.3.4 Clock Source.....	22	9.4 Layout.....	74
7.3.5 Delta-Sigma Modulator.....	23	9.4.1 Layout Guidelines.....	74
7.3.6 Digital Filter.....	23	9.4.2 Layout Example.....	75
7.3.7 Excitation Current Sources (IDACs).....	28	<b>10 Device and Documentation Support</b> .....	76
7.3.8 Burn-Out Current Sources (BOCS).....	29	10.1 Documentation Support.....	76
7.3.9 General Purpose IOs (GPIOs).....	29	10.1.1 Related Documentation.....	76
7.3.10 System Monitors.....	30	10.2 Receiving Notification of Documentation Updates..	76
7.3.11 Monitors and Status Flags.....	31	10.3 Support Resources.....	76
7.4 Device Functional Modes.....	33	10.4 Trademarks.....	76
7.4.1 Power-up and Reset.....	33	10.5 Electrostatic Discharge Caution.....	76
7.4.2 Operating Modes.....	34	10.6 Glossary.....	76
7.5 Programming.....	36	<b>11 Revision History</b> .....	76
7.5.1 I <sup>2</sup> C Interface.....	36	<b>12 Mechanical, Packaging, and Orderable Information</b> .....	76
7.5.2 I <sup>2</sup> C Address.....	36		
7.5.3 Serial Clock (SCL) and Serial Data (SDA).....	36		
7.5.4 I <sup>2</sup> C Bus Speed.....	36		
7.5.5 I <sup>2</sup> C Data Transfer Protocol.....	37		
7.5.6 I <sup>2</sup> C General Call (Software Reset).....	37		

## 4 Pin Configuration and Functions

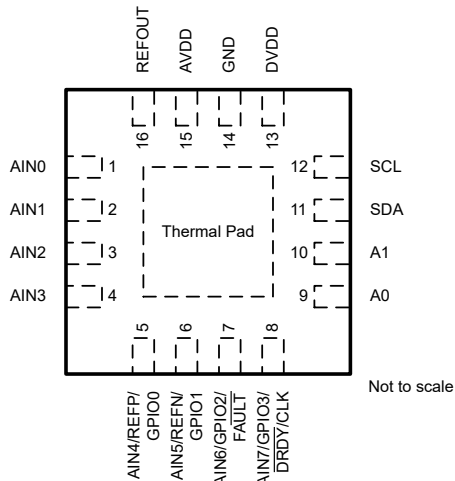

**Figure 4-1. ADS1x2C14, RTE Package, 16-pin WQFN, Top View**

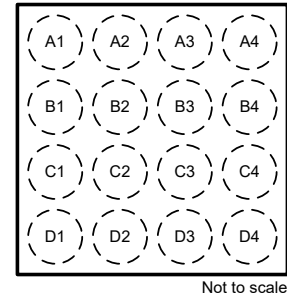

**Figure 4-2. ADS1x2C14, YBH Package, 16-pin DSBGA, Top View**

**Table 4-1. ADS1x2C14 Pin Functions**

NAME	PIN		TYPE	DESCRIPTION <sup>(1)</sup>
	RTE	YBH		
A0	9	C2	Digital Input	I <sup>2</sup> C target address select pin 0. See the <a href="#">I<sup>2</sup>C Address</a> section for details. <sup>(5)</sup>
A1	10	D1	Digital Input	I <sup>2</sup> C target address select pin 1. See the <a href="#">I<sup>2</sup>C Address</a> section for details. <sup>(5)</sup>
AIN0	1	A4	Analog Input	Analog input 0
AIN1	2	B4	Analog Input	Analog input 1
AIN2	3	C4	Analog Input	Analog input 2
AIN3	4	D4	Analog Input	Analog input 3
AIN4/REFP/ GPIO0	5	B3	Analog Input/ Digital IO	Analog input 4. Positive external reference input. General purpose digital input/output 0. <sup>(2) (4)</sup>
AIN5/REFN/ GPIO1	6	C3	Analog Input/ Digital IO	Analog input 5. Negative external reference input. General purpose digital input/output 1. <sup>(2) (4)</sup>
AIN6/ GPIO2/FAULT	7	D3	Analog Input/ Digital IO	Analog input 6. General purpose digital input/output 2. <sup>(2) (4)</sup> Pin can be configured as dedicated FAULT output.
AIN7/ GPIO3/DRDY/CLK	8	D2	Analog Input/ Digital IO	Analog input 7. General purpose digital input/output 3. <sup>(2) (4)</sup> Pin can be configured as dedicated DRDY output or external clock input.
AVDD	15	A2	Analog Supply	Positive analog supply. Connect a 100nF capacitor to GND.
DVDD	13	A1	Digital Supply	Digital supply. Connect a 100nF capacitor to GND.
GND	14	B2	Ground	Ground
REFOUT	16	A3	Analog Output	Internal voltage reference output. Connect a 100nF capacitor to GND.
SCL	12	B1	Digital Input	Serial clock input. Connect to DVDD using a pullup resistor. <sup>(5)</sup>
SDA	11	C1	Digital Output	Serial data input and output. Connect to DVDD using a pullup resistor. <sup>(3) (5)</sup>
Thermal Pad	-	N/A	-	Thermal power pad. Connect to GND.

(1) See the [Unused Inputs and Outputs](#) section for details on how to connect unused pins.

(2) Configurable as push-pull or open-drain output.

(3) Open-drain output.

(4) Logic levels referenced to AVDD.

(5) Logic levels referenced to DVDD.

## 5 Specifications

### 5.1 Absolute Maximum Ratings

over operating ambient temperature range (unless otherwise noted)<sup>(1)</sup>

		MIN	MAX	UNIT
Power supply voltage	AVDD to GND	-0.3	5	V
	DVDD to GND	-0.3	5.5	V
Analog input voltage	AINx, REFP, REFN	GND - 0.3	AVDD + 0.3	V
Digital input voltage	GPIO0, GPIO1, GPIO2/ $\overline{\text{FAULT}}$ , GPIO3/ $\overline{\text{DRDY}}$ /CLK	GND - 0.3	AVDD + 0.3	V
Digital input voltage	SCL, SDA, A0	GND - 0.3	5.5	V
	A1	GND - 0.3	DVDD + 0.3	V
Input current	Continuous, any pin except power-supply pins	-10	10	mA
Temperature	Junction, T <sub>J</sub>		140	°C
	Storage, T <sub>stg</sub>	-60	150	°C

- (1) Operation outside the *Absolute Maximum Ratings* may cause permanent device damage. *Absolute Maximum Ratings* do not imply functional operation of the device at these or any other conditions beyond those listed under *Recommended Operating Conditions*. If used outside the *Recommended Operating Conditions* but within the *Absolute Maximum Ratings*, the device may not be fully functional, and this may affect device reliability, functionality, performance, and shorten the device lifetime.

### 5.2 ESD Ratings

			VALUE	UNIT
V <sub>(ESD)</sub>	Electrostatic discharge	Human body model (HBM), per ANSI/ESDA/JEDEC JS-001 <sup>(1)</sup>	±2000	V
		Charged-device model (CDM), per ANSI/ESDA/JEDEC JS-002 <sup>(2)</sup>	±750	

- (1) JEDEC document JEP155 states that 500V HBM allows safe manufacturing with a standard ESD control process.  
 (2) JEDEC document JEP157 states that 250V CDM allows safe manufacturing with a standard ESD control process.

### 5.3 Recommended Operating Conditions

over operating ambient temperature range (unless otherwise noted)

			MIN	NOM	MAX	UNIT
<b>POWER SUPPLY</b>						
	Analog power supply	AVDD to GND, $I_{IDAC} \leq 500\mu A$	1.74		3.6	V
		AVDD to GND, $I_{IDAC} > 500\mu A$ or internal $V_{REF} = 2.5V$	2.7		3.6	
	Digital power supply	DVDD to GND	1.65		3.6	V
<b>ANALOG INPUTS<sup>(1)</sup></b>						
$V_{AINx}$	Absolute input voltage	Gain = 0.5 to 10	GND		AVDD – 0.35	V
		Gain = 16 to 256	GND + 0.35		AVDD – 0.4	
$V_{IN}$	Differential input voltage <sup>(2)</sup>	Unipolar straight binary coding	0		$V_{REF} / \text{Gain}$	V
		Binary two's complement coding	$-V_{REF} / \text{Gain}$		$V_{REF} / \text{Gain}$	
<b>VOLTAGE REFERENCE INPUTS</b>						
$V_{REF}$	Differential reference input voltage	$V_{REF} = (V_{REFP} - V_{REFN})$	0.5		AVDD	V
$V_{REFN}$	Absolute negative reference voltage	Negative reference buffer disabled	GND – 0.05			V
		Negative reference buffer enabled	GND + 0.1			V
$V_{REFP}$	Absolute positive reference voltage	Positive reference buffer disabled			AVDD + 0.05	V
		Positive reference buffer enabled			AVDD – 0.1	V
<b>EXTERNAL CLOCK SOURCE<sup>(3)</sup></b>						
$f_{CLK}$	External clock frequency		3	4.096	4.15	MHz
	Duty Cycle		40%	50%	60%	
<b>GENERAL-PURPOSE INPUTS (GPIOs)</b>						
	Input voltage		GND		AVDD	V
<b>DIGITAL INPUTS (other than GPIOs)</b>						
	Input voltage	SCL, SDA, A0	GND		5.5	V
		A1	GND		DVDD	V
<b>TEMPERATURE RANGE</b>						
	Specified ambient temperature		–40		125	°C
$T_A$	Operating ambient temperature		–50		125	°C

- (1)  $A_{INP}$  and  $A_{INN}$  denote the positive and negative inputs of the PGA. Any of the available analog inputs ( $A_{INx}$ ) can be selected as either  $A_{INP}$  or  $A_{INN}$  by the input multiplexer.
- (2)  $V_{IN} = (V_{AINP} - V_{AINN})$ . Excluding the effects of offset and gain error.
- (3) An external clock is not required when the internal oscillator is used.

### 5.4 Thermal Information

THERMAL METRIC <sup>(1)</sup>		WQFN (RTE)	DSBGA (YBH)	UNIT
		16 PINS	16 PINS	
$R_{\theta JA}$	Junction-to-ambient thermal resistance	59.3	86.4	°C/W
$R_{\theta JC(top)}$	Junction-to-case (top) thermal resistance	40.2	0.2	°C/W
$R_{\theta JB}$	Junction-to-board thermal resistance	31.6	22.9	°C/W
$\Psi_{JT}$	Junction-to-top characterization parameter	0.8	0.2	°C/W
$\Psi_{JB}$	Junction-to-board characterization parameter	31.5	22.9	°C/W
$R_{\theta JC(bot)}$	Junction-to-case (bottom) thermal resistance	27.2	N/A	°C/W

- (1) For more information about traditional and new thermal metrics, see the [Semiconductor and IC Package Thermal Metrics](#) application note.

## 5.5 Electrical Characteristics

minimum and maximum specifications apply from  $T_A = -40^\circ\text{C}$  to  $+125^\circ\text{C}$ ; typical specifications are at  $T_A = 25^\circ\text{C}$ ; all specifications are at  $AVDD = 1.74\text{V}$  to  $3.6\text{V}$ ,  $DVDD = 1.65\text{V}$  to  $3.6\text{V}$ , internal reference, internal oscillator, all speed modes, all data rates, all gain settings, and global chop disabled (unless otherwise noted)

PARAMETER	TEST CONDITIONS	MIN	TYP	MAX	UNIT	
<b>ANALOG INPUTS</b>						
Absolute input current <sup>(1)</sup>	All gains, $f_{\text{DATA}} = 20\text{SPS}$ or $25\text{SPS}$ , global chop enabled or disabled, $V_{\text{AINX(MIN)}} \leq V_{\text{AINX}} \leq V_{\text{AINX(MAX)}}$ , $V_{\text{IN}} = 0\text{V}$	-2	$\pm 0.3$	2	nA	
Absolute input current drift <sup>(1)</sup>	All gains, $f_{\text{DATA}} = 20\text{SPS}$ or $25\text{SPS}$ , global chop enabled or disabled, $V_{\text{AINX(MIN)}} \leq V_{\text{AINX}} \leq V_{\text{AINX(MAX)}}$ , $V_{\text{IN}} = 0\text{V}$		2		pA/ $^\circ\text{C}$	
Differential input current <sup>(1)</sup>	All gains, $f_{\text{DATA}} = 20\text{SPS}$ or $25\text{SPS}$ , global chop enabled or disabled, $V_{\text{CM}} = AVDD/2$ , $-V_{\text{REF}/\text{Gain}} \leq V_{\text{IN}} \leq V_{\text{REF}/\text{Gain}}$	-2	$\pm 0.1$	2	nA	
Differential input current drift <sup>(1)</sup>	All gains, $f_{\text{DATA}} = 20\text{SPS}$ or $25\text{SPS}$ , global chop enabled or disabled, $V_{\text{CM}} = AVDD/2$ , $-V_{\text{REF}/\text{Gain}} \leq V_{\text{IN}} \leq V_{\text{REF}/\text{Gain}}$		2		pA/ $^\circ\text{C}$	
<b>PGA</b>						
Gain settings			0.5, 1, 2, 4, 5, 8, 10, 16, 20, 32, 50, 64, 100, 128, 200, 256			
<b>SYSTEM PERFORMANCE</b>						
Resolution (no missing codes)	ADS112C14	16			Bits	
	ADS122C14	24				
$f_{\text{DATA}}$	Output data rate	Speed mode 0 ( $f_{\text{MOD}} = 32\text{kHz}$ )	20		2k	SPS
		Speed mode 1 ( $f_{\text{MOD}} = 256\text{kHz}$ )	20		16k	
		Speed mode 2 ( $f_{\text{MOD}} = 512\text{kHz}$ )	20		32k	
		Speed mode 3 ( $f_{\text{MOD}} = 1024\text{kHz}$ )	20		64k	
INL	Integral nonlinearity	$V_{\text{CM}} = AVDD/2$ , best fit		5	15	ppm <sub>FSR</sub>
$V_{\text{IO}}$	Input offset voltage	$T_A = 25^\circ\text{C}$ , gain = 0.5, global chop disabled	-250	$\pm 50$	250	$\mu\text{V}$
		$T_A = 25^\circ\text{C}$ , gains = 1 to 10, global chop disabled	-150	$\pm 20$	150	
		$T_A = 25^\circ\text{C}$ , gain $\geq 16$ , global chop disabled	-50	$\pm 10$	50	
		$T_A = 25^\circ\text{C}$ , gain = 0.5, global chop enabled	-5	$\pm 0.5$	5	
		$T_A = 25^\circ\text{C}$ , gain $\geq 1$ , global chop enabled	-2	$\pm 0.2$	2	
Offset drift		Gains $\leq 10$ , global chop disabled		60	300	nV/ $^\circ\text{C}$
		Gains $\geq 16$ , global chop disabled		20	125	
		All gains, global chop enabled		10	50	
Gain error		$T_A = 25^\circ\text{C}$ , all gains, external reference	-0.3	$\pm 0.08$	0.3	%
Gain drift		All gains, external reference		0.5	2.5	ppm/ $^\circ\text{C}$
Noise (input-referred)		See the <a href="#">Noise Performance</a> section				
NMRR	Normal-mode rejection ratio	$f_{\text{IN}} = 50\text{Hz}$ or $60\text{Hz}$ ( $\pm 1\text{Hz}$ ), $f_{\text{DATA}} = 20\text{SPS}$	82	95		dB
		$f_{\text{IN}} = 50\text{Hz}$ or $60\text{Hz}$ ( $\pm 1\text{Hz}$ ), $f_{\text{DATA}} = 20\text{SPS}$ , external $f_{\text{CLK}} = 4.096\text{MHz}$	95			
		$f_{\text{IN}} = 50\text{Hz}$ or $60\text{Hz}$ ( $\pm 1\text{Hz}$ ), $f_{\text{DATA}} = 25\text{SPS}$	57	62		
		$f_{\text{IN}} = 50\text{Hz}$ or $60\text{Hz}$ ( $\pm 1\text{Hz}$ ), $f_{\text{DATA}} = 25\text{SPS}$ , external $f_{\text{CLK}} = 4.096\text{MHz}$	62			
CMRR	Common-mode rejection ratio	At dc		120		dB
		$f_{\text{CM}} = 50\text{Hz}$ or $60\text{Hz}$ ( $\pm 1\text{Hz}$ ), $f_{\text{DATA}} = 20\text{SPS}$ or $25\text{SPS}$		130		
		$f_{\text{CM}} = 50\text{Hz}$ or $60\text{Hz}$ ( $\pm 1\text{Hz}$ ), $f_{\text{DATA}} > 25\text{SPS}$		120		
PSRR	Power-supply rejection ratio	AVDD at dc		110		dB
		DVDD at dc		115		

minimum and maximum specifications apply from  $T_A = -40^{\circ}\text{C}$  to  $+125^{\circ}\text{C}$ ; typical specifications are at  $T_A = 25^{\circ}\text{C}$ ; all specifications are at  $\text{AVDD} = 1.74\text{V}$  to  $3.6\text{V}$ ,  $\text{DVDD} = 1.65\text{V}$  to  $3.6\text{V}$ , internal reference, internal oscillator, all speed modes, all data rates, all gain settings, and global chop disabled (unless otherwise noted)

PARAMETER		TEST CONDITIONS	MIN	TYP	MAX	UNIT
<b>VOLTAGE REFERENCE INPUTS</b>						
Absolute input current		REF buffer disabled, speed mode 0 <sup>(2)</sup>	-1.5	±1	1.5	µA/V
		REF buffer disabled, speed mode 1 <sup>(2)</sup>	-7	±6	7	
		REF buffer disabled, speed mode 2 <sup>(2)</sup>	-8	±7	8	
		REF buffer disabled, speed mode 3 <sup>(2)</sup>	-9	±8	9	
		REF buffer enabled, speed mode 0	-2	±0.2	2	nA
		REF buffer enabled, speed mode 1		3	7	
		REF buffer enabled, speed mode 2		10	12	
		REF buffer enabled, speed mode 3		17	23	
<b>INTERNAL VOLTAGE REFERENCE</b>						
$V_{\text{REF}}$	Output voltage	$\text{AVDD} < 2.7\text{V}$		1.25		V
		$\text{AVDD} \geq 2.7\text{V}$		1.25, 2.5		
	Accuracy	$T_A = 25^{\circ}\text{C}$	-0.15	±0.05	0.15	%
	Temperature drift			10	25	ppm/°C
	Output current	$V_{\text{REF}} = 1.25\text{V}$ , sink or source	-5		5	mA
		$V_{\text{REF}} = 2.5\text{V}$ , $\text{AVDD} \geq 2.75\text{V}$ , sink or source	-10		5	
	Short-circuit current limit	Sink or source		±25		mA
PSRR	Power-supply rejection ratio	$\text{AVDD}$ at dc		90		dB
	Load regulation	Load current = -5mA to 0mA (source)		100		µV/mA
	Capacitive load stability		50	100	1300	nF
	Reference noise	$f = 0.1\text{Hz}$ to $10\text{Hz}$ , 100nF capacitor on REFOUT		4		ppm <sub>pp</sub>
	Start-up time	From power-down mode, 100nF capacitor on REFOUT, 0.01% settling			10	ms
<b>INTERNAL OSCILLATOR</b>						
$f_{\text{OSC}}$	Frequency			4.096		MHz
	Accuracy		-1		1	%
<b>EXCITATION CURRENT SOURCES (IDACS)</b>						
	Current settings	IDAC unit current = 1µA		1 to 100		µA
		IDAC unit current = 10µA, $\text{AVDD} < 2.7\text{V}$		10 to 500		
		IDAC unit current = 10µA, $\text{AVDD} \geq 2.7\text{V}$		10 to 1000		
	Compliance voltage	$I_{\text{IDAC}} < 100\mu\text{A}$ , current changes by less than 1% from $(\text{AVDD} - 1\text{V})$	GND		$\text{AVDD} - 0.3$	V
		$I_{\text{IDAC}} = 100\mu\text{A}$ to $700\mu\text{A}$ , current changes by less than 1% from $(\text{AVDD} - 1\text{V})$	GND		$\text{AVDD} - 0.4$	
		$I_{\text{IDAC}}$ current $\geq 800\mu\text{A}$ , current changes by less than 1% from $(\text{AVDD} - 1\text{V})$	GND		$\text{AVDD} - 0.45$	
	Accuracy	$I_{\text{IDAC}} = 1\mu\text{A}$ , $T_A = 25^{\circ}\text{C}$	-6	±0.4	6	%
		$I_{\text{IDAC}} = 10\mu\text{A}$ to $1\text{mA}$ , $T_A = 25^{\circ}\text{C}$	-3	±0.4	3	
	Current mismatch between IDACs	$I_{\text{IDAC}} \leq 10\mu\text{A}$ , IDAC1 and IDAC2 set to same value, $T_A = 25^{\circ}\text{C}$		0.5	2	%
		$I_{\text{IDAC}} \geq 20\mu\text{A}$ , IDAC1 and IDAC2 set to same value, $T_A = 25^{\circ}\text{C}$		0.05	0.5	
	Temperature drift	$I_{\text{IDAC}} = 1\mu\text{A}$		50	300	ppm/°C
		$I_{\text{IDAC}} \geq 10\mu\text{A}$		25	110	
	Temperature drift matching	$I_{\text{IDAC}} \leq 10\mu\text{A}$ , IDAC1 and IDAC2 set to same value		12	70	ppm/°C
		$I_{\text{IDAC}} \geq 20\mu\text{A}$ , IDAC1 and IDAC2 set to same value		1	10	

minimum and maximum specifications apply from  $T_A = -40^{\circ}\text{C}$  to  $+125^{\circ}\text{C}$ ; typical specifications are at  $T_A = 25^{\circ}\text{C}$ ; all specifications are at  $\text{AVDD} = 1.74\text{V}$  to  $3.6\text{V}$ ,  $\text{DVDD} = 1.65\text{V}$  to  $3.6\text{V}$ , internal reference, internal oscillator, all speed modes, all data rates, all gain settings, and global chop disabled (unless otherwise noted)

PARAMETER		TEST CONDITIONS	MIN	TYP	MAX	UNIT
<b>BURNOUT CURRENT SOURCES (BOCS)</b>						
	Current settings			0.2, 1, 10		$\mu\text{A}$
	Accuracy	Sink and source		$\pm 2$		%
<b>TEMPERATURE SENSOR</b>						
$\text{TS}_{\text{Offset}}$	Output voltage	$T_A = 25^{\circ}\text{C}$		119.5		mV
$\text{TS}_{\text{TC}}$	Temperature coefficient			405		$\mu\text{V}/^{\circ}\text{C}$
<b>MONITORS</b>						
$\text{TH}_{\text{DVDD\_POR}}$	DVDD POR threshold			1.55		V
$\text{TH}_{\text{AVDD\_UV}}$	AVDD undervoltage threshold <sup>(3)</sup>		1.2		1.5	V
$\text{TH}_{\text{REF\_UV}}$	Reference undervoltage threshold <sup>(3)</sup>		0.5		0.6	V
	System monitor voltage readback accuracy	$(V_{\text{REFP}} - V_{\text{REFN}}) / 8$		$\pm 0.5$		%
		$\text{AVDD} / 8$		$\pm 1$		
		$\text{DVDD} / 8$		$\pm 1$		
<b>GENERAL-PURPOSE INPUTS/OUTPUTS (GPIOs)</b>						
$V_{\text{IL}}$	Logic input level, low		GND		$0.3 \text{ AVDD}$	V
$V_{\text{IH}}$	Logic input level, high		$0.7 \text{ AVDD}$		$\text{AVDD}$	V
$V_{\text{OL}}$	Logic output level, low	$I_{\text{OL}} = 100\mu\text{A}$ , open-drain or push-pull output	GND		$0.2 \text{ AVDD}$	V
$V_{\text{OH}}$	Logic output level, high	$I_{\text{OH}} = -100\mu\text{A}$ , push-pull output	$0.8 \text{ AVDD}$		$\text{AVDD}$	V
	Input hysteresis			10		mV
<b>DIGITAL INPUTS/OUTPUTS</b>						
$V_{\text{IL}}$	Logic input level, low		GND		$0.3 \text{ DVDD}$	V
$V_{\text{IH}}$	Logic input level, high		$0.7 \text{ DVDD}$		5.5	V
$V_{\text{hys}}$	Hysteresis of Schmitt-trigger inputs			180		mV
$V_{\text{OL}}$	Logic output level, low	$I_{\text{OL}} = 3\text{mA}$	GND		0.3	V
$I_{\text{OL}}$	Low-level output current	$V_{\text{OL}} = 0.4\text{V}$ , fast-mode plus, $\text{DVDD} = 1.65\text{V}$ to $2\text{V}$		12		mA
		$V_{\text{OL}} = 0.4\text{V}$ , fast-mode plus, $\text{DVDD} = 2\text{V}$ to $3.6\text{V}$		20		
		$V_{\text{OL}} = 0.6\text{V}$ , fast-mode		6		
$C_{\text{i}}$	Capacitance	Each pin			10	pF
	Input current	$\text{GND} \leq V_{\text{Digital Input}} \leq \text{DVDD}$		-1	1	$\mu\text{A}$

minimum and maximum specifications apply from  $T_A = -40^{\circ}\text{C}$  to  $+125^{\circ}\text{C}$ ; typical specifications are at  $T_A = 25^{\circ}\text{C}$ ; all specifications are at  $AVDD = 1.74\text{V}$  to  $3.6\text{V}$ ,  $DVDD = 1.65\text{V}$  to  $3.6\text{V}$ , internal reference, internal oscillator, all speed modes, all data rates, all gain settings, and global chop disabled (unless otherwise noted)

PARAMETER	TEST CONDITIONS	MIN	TYP	MAX	UNIT	
<b>ANALOG SUPPLY CURRENTS (<math>AVDD = 3.3\text{V}</math>, External Reference, Reference Buffers Disabled, IDACs Disabled, All Data Rates, <math>V_{IN} = 0\text{V}</math>)</b>						
$I_{AVDD}$	Analog supply current	Power-down mode		0.2	2	$\mu\text{A}$
		Standby mode		10	16	
		Conversion mode, speed mode 0, gain = 0.5 to 2		52	59	
		Conversion mode, speed mode 0, gain = 4 and 5		55	63	
		Conversion mode, speed mode 0, gain = 8 to 50		61	68	
		Conversion mode, speed mode 0, gain = 64 to 256		57	64	
		Conversion mode, speed mode 1, gain = 0.5 to 2		135	145	
		Conversion mode, speed mode 1, gain = 4 and 5		155	170	
		Conversion mode, speed mode 1, gain = 8 to 50		205	220	
		Conversion mode, speed mode 1, gain = 64 to 256		255	275	
		Conversion mode, speed mode 2, gain = 0.5 to 2		315	335	
		Conversion mode, speed mode 2, gain = 4 and 5		360	380	
		Conversion mode, speed mode 2, gain = 8 to 50		450	480	
		Conversion mode, speed mode 2, gain = 64 to 256		670	705	
		Conversion mode, speed mode 3, gain = 0.5 to 2		540	570	
		Conversion mode, speed mode 3, gain = 4 and 5		640	680	
Conversion mode, speed mode 3, gain = 8 to 50		870	920			
Conversion mode, speed mode 3, gain = 64 to 256		1090	1140			
<b>ADDITIONAL ANALOG SUPPLY CURRENTS PER FUNCTION (<math>AVDD = 3.3\text{V}</math>, <math>V_{REF} = 2.5\text{V}</math>)</b>						
$I_{AVDD}$	Analog supply current	Internal voltage reference, speed mode 0		4.5	6	$\mu\text{A}$
		Internal voltage reference, speed mode 1		25	28	
		Internal voltage reference, speed mode 2		35	40	
		Internal voltage reference, speed mode 3		65	75	
		Either REFP or REFN buffer enabled, speed mode 0		4.5	6	
		Either REFP or REFN buffer enabled, speed mode 1		25	28	
		Either REFP or REFN buffer enabled, speed mode 2		35	40	
		Either REFP or REFN buffer enabled, speed mode 3		65	75	
		Both REFP and REFN buffers enabled, speed mode 0		6.5	9	
		Both REFP and REFN buffers enabled, speed mode 1		33	39	
		Both REFP and REFN buffers enabled, speed mode 2		51	60	
		Both REFP and REFN buffers enabled, speed mode 3		106	124	
		IDAC overhead, IDAC unit current = $1\mu\text{A}$		4	6	
IDAC overhead, IDAC unit current = $10\mu\text{A}$		16	28			
<b>DIGITAL SUPPLY CURRENTS (<math>DVDD = 3.3\text{V}</math>, All Data Rates, <math>I^2\text{C}</math> Not Active)</b>						
$I_{DVDD}$	Digital supply current	Power-down mode		1.6	6.5	$\mu\text{A}$
		Standby mode, speed mode 0		8	13	
		Standby mode, speed mode 1		20	26	
		Standby mode, speed mode 2		26	33	
		Standby mode, speed mode 3		40	47	
		Conversion mode, speed mode 0		9	16	
		Conversion mode, speed mode 1		30	38	
		Conversion mode, speed mode 2		48	56	
Conversion mode, speed mode 3		82	92			

minimum and maximum specifications apply from  $T_A = -40^\circ\text{C}$  to  $+125^\circ\text{C}$ ; typical specifications are at  $T_A = 25^\circ\text{C}$ ; all specifications are at  $AVDD = 1.74\text{V}$  to  $3.6\text{V}$ ,  $DVDD = 1.65\text{V}$  to  $3.6\text{V}$ , internal reference, internal oscillator, all speed modes, all data rates, all gain settings, and global chop disabled (unless otherwise noted)

PARAMETER		TEST CONDITIONS	MIN	TYP	MAX	UNIT
<b>ANALOG SUPPLY CURRENTS (<math>AVDD = 1.8\text{V}</math>, External Reference, Reference Buffers Disabled, IDACs Disabled, All Data Rates, <math>V_{IN} = 0\text{V}</math>)</b>						
$I_{AVDD}$	Analog supply current	Power-down mode		0.2	2	$\mu\text{A}$
		Standby mode		8	14	
		Conversion mode, speed mode 0, gain = 0.5 to 2		48	55	
		Conversion mode, speed mode 0, gain = 4 and 5		51	58	
		Conversion mode, speed mode 0, gain = 8 to 50		57	64	
		Conversion mode, speed mode 0, gain = 64 to 256		53	60	
		Conversion mode, speed mode 1, gain = 0.5 to 2		120	130	
		Conversion mode, speed mode 1, gain = 4 and 5		140	155	
		Conversion mode, speed mode 1, gain = 8 to 50		190	205	
		Conversion mode, speed mode 1, gain = 64 to 256		240	260	
		Conversion mode, speed mode 2, gain = 0.5 to 2		285	305	
		Conversion mode, speed mode 2, gain = 4 and 5		325	345	
		Conversion mode, speed mode 2, gain = 8 to 50		420	445	
		Conversion mode, speed mode 2, gain = 64 to 256		635	670	
		Conversion mode, speed mode 3, gain = 0.5 to 2		485	515	
		Conversion mode, speed mode 3, gain = 4 and 5		580	620	
Conversion mode, speed mode 3, gain = 8 to 50		810	860			
Conversion mode, speed mode 3, gain = 64 to 256		1020	1080			
<b>ADDITIONAL ANALOG SUPPLY CURRENTS PER FUNCTION (<math>AVDD = 1.8\text{V}</math>, <math>V_{REF} = 1.25\text{V}</math>)</b>						
$I_{AVDD}$	Analog supply current	Internal voltage reference, speed mode 0		3.5	5	$\mu\text{A}$
		Internal voltage reference, speed mode 1		16	20	
		Internal voltage reference, speed mode 2		26	31	
		Internal voltage reference, speed mode 3		56	66	
		Either REFP or REFN buffer enabled, speed mode 0		3.5	5	
		Either REFP or REFN buffer enabled, speed mode 1		16	20	
		Either REFP or REFN buffer enabled, speed mode 2		26	31	
		Either REFP or REFN buffer enabled, speed mode 3		56	66	
		Both REFP and REFN buffers enabled, speed mode 0		5.5	8	
		Both REFP and REFN buffers enabled, speed mode 1		25	30	
		Both REFP and REFN buffers enabled, speed mode 2		43	53	
		Both REFP and REFN buffers enabled, speed mode 3		100	120	
		IDAC overhead, IDAC unit current = $1\mu\text{A}$		4	6	
		IDAC overhead, IDAC unit current = $10\mu\text{A}$		16	28	
<b>DIGITAL SUPPLY CURRENTS (<math>DVDD = 1.8\text{V}</math>, All Data Rates, <math>I^2\text{C}</math> Not Active)</b>						
$I_{DVDD}$	Digital supply current	Power-down mode		1.6	6.5	$\mu\text{A}$
		Standby mode, speed mode 0		7	13	
		Standby mode, speed mode 1		19	26	
		Standby mode, speed mode 2		25	33	
		Standby mode, speed mode 3		39	47	
		Conversion mode, speed mode 0		9	16	
		Conversion mode, speed mode 1		30	38	
		Conversion mode, speed mode 2		48	56	
Conversion mode, speed mode 3		82	92			

- (1) Input currents scale with speed mode, data rate, gain, and global-chop mode settings.
- (2) Current is flowing into REFP and out of REFN.
- (3) Undervoltage monitor does always trip below the specified MIN value and does never trip above the specified MAX value.

## 5.6 I<sup>2</sup>C Timing Requirements

over operating ambient temperature range and DVDD = 1.65V to 3.6V (unless otherwise noted)

		MIN	MAX	UNIT
<b>STANDARD-MODE (Sm)</b>				
f <sub>SCL</sub>	SCL clock frequency	0	100	kHz
t <sub>HD,STA</sub>	Hold time, (repeated) START condition. After this period, the first clock pulse is generated.	4		μs
t <sub>LOW</sub>	Pulse duration, SCL low	4.7		μs
t <sub>HIGH</sub>	Pulse duration, SCL high	4.0		μs
t <sub>SU,STA</sub>	Setup time, repeated START condition	4.7		μs
t <sub>HD,DAT</sub>	Hold time, data	0		μs
t <sub>SU,DAT</sub>	Setup time, data	250		ns
t <sub>r</sub>	Rise time, SCL, SDA		1000	ns
t <sub>f</sub>	Fall time, SCL, SDA		250	ns
t <sub>SU,STO</sub>	Setup time, STOP condition	4.0		μs
t <sub>BUF</sub>	Bus free time, between STOP and START conditions	4.7		μs
t <sub>VD,DAT</sub>	Valid time, data		3.45	μs
t <sub>VD,ACK</sub>	Valid time, acknowledge		3.45	μs
<b>FAST-MODE (Fm)</b>				
f <sub>SCL</sub>	SCL clock frequency	0	400	kHz
t <sub>HD,STA</sub>	Hold time, (repeated) START condition. After this period, the first clock pulse is generated.	0.6		μs
t <sub>LOW</sub>	Pulse duration, SCL low	1.3		μs
t <sub>HIGH</sub>	Pulse duration, SCL high	0.6		μs
t <sub>SU,STA</sub>	Setup time, repeated START condition	0.6		μs
t <sub>HD,DAT</sub>	Hold time, data	0		μs
t <sub>SU,DAT</sub>	Setup time, data	100		ns
t <sub>r</sub>	Rise time, SCL, SDA	20	300	ns
t <sub>f</sub>	Fall time, SCL, SDA		250	ns
t <sub>SU,STO</sub>	Setup time, STOP condition	0.6		μs
t <sub>BUF</sub>	Bus free time, between STOP and START conditions	1.3		μs
t <sub>VD,DAT</sub>	Valid time, data		0.9	μs
t <sub>VD,ACK</sub>	Valid time, acknowledge		0.9	μs
t <sub>SP</sub>	Pulse duration of spikes that must be suppressed by the input filter	0	50	ns
<b>FAST-MODE PLUS (Fm+)</b>				
f <sub>SCL</sub>	SCL clock frequency	0	1000	kHz
t <sub>HD,STA</sub>	Hold time, (repeated) START condition. After this period, the first clock pulse is generated.	0.26		μs
t <sub>LOW</sub>	Pulse duration, SCL low	0.5		μs
t <sub>HIGH</sub>	Pulse duration, SCL high	0.26		μs
t <sub>SU,STA</sub>	Setup time, repeated START condition	0.26		μs
t <sub>HD,DAT</sub>	Hold time, data	0		μs
t <sub>SU,DAT</sub>	Setup time, data	50		ns
t <sub>r</sub>	Rise time, SCL, SDA		120	ns
t <sub>f</sub>	Fall time, SCL, SDA		120	ns
t <sub>SU,STO</sub>	Setup time, STOP condition	0.26		μs
t <sub>BUF</sub>	Bus free time, between STOP and START conditions	0.5		μs
t <sub>VD,DAT</sub>	Valid time, data		0.45	μs
t <sub>VD,ACK</sub>	Valid time, acknowledge		0.45	μs
t <sub>SP</sub>	Pulse duration of spikes that must be suppressed by the input filter	0	50	ns

over operating ambient temperature range and DVDD = 1.65V to 3.6V (unless otherwise noted)

		MIN	MAX	UNIT
<b>RESET</b>				
$t_{d(RST)}$	Delay time, I <sup>2</sup> C communication start after software reset using RESET[5:0] bit field	500		$\mu$ s
$t_{d(POR)}$	Delay time, I <sup>2</sup> C communication start after DVDD exceeds minimum DVDD voltage	5		ms

### 5.7 I<sup>2</sup>C Switching Characteristics

over operating ambient temperature range, DVDD = 1.65V to 3.6V (unless otherwise noted)

PARAMETER	TEST CONDITIONS	MIN	TYP	MAX	UNIT
$t_{w(DRH)}$	Pulse duration, DRDY high	2			$t_{MOD}$

### 5.8 Timing Diagrams

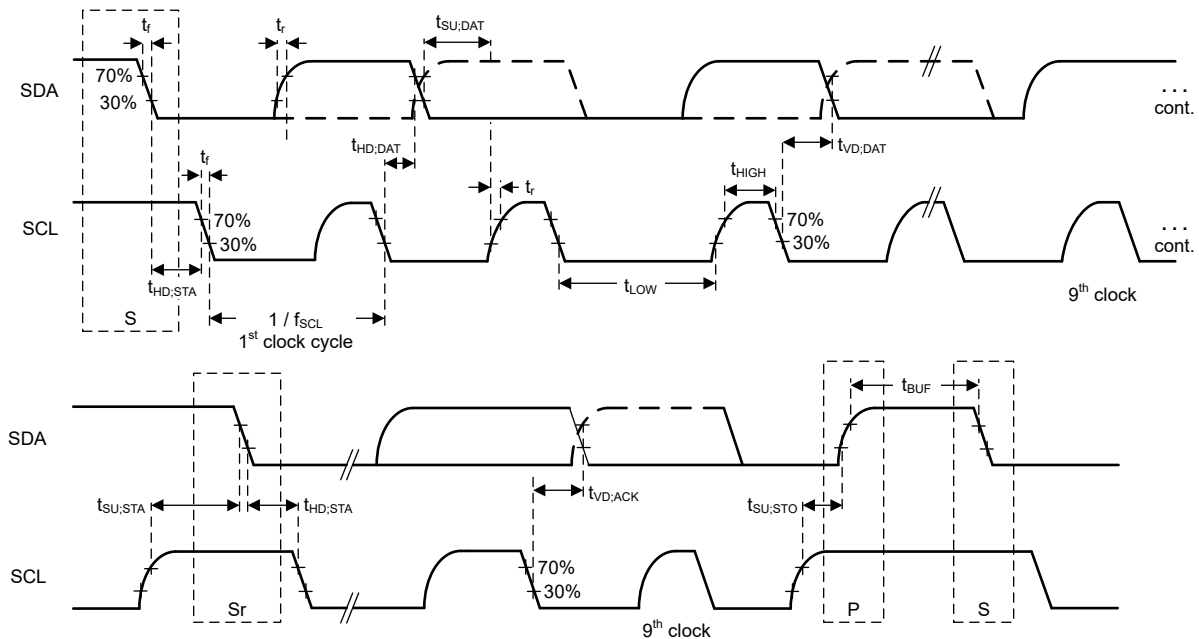

Figure 5-1. I<sup>2</sup>C Timing Requirements

## 5.9 Typical Characteristics

at  $T_A = 25^\circ\text{C}$  (unless otherwise noted)

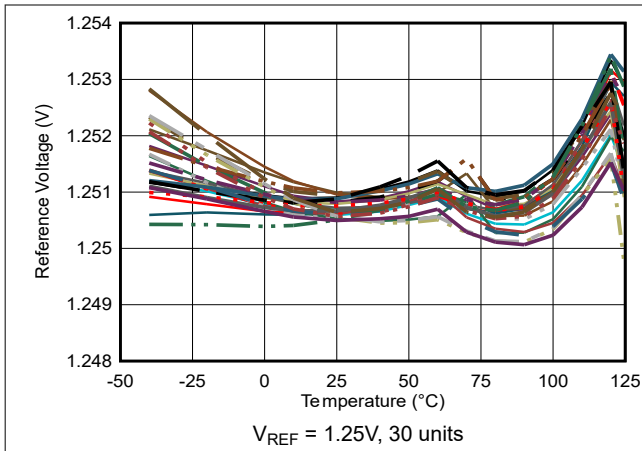

Figure 5-2. Internal Reference Voltage vs Temperature

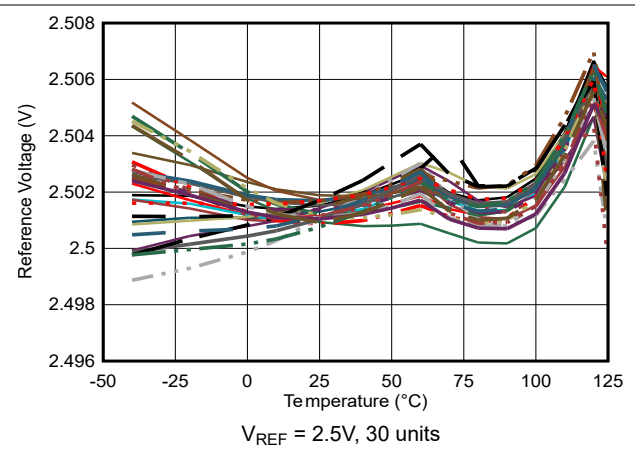

Figure 5-3. Internal Reference Voltage vs Temperature

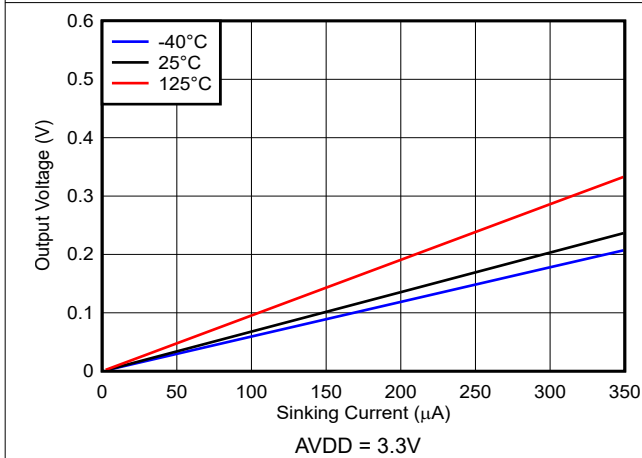

Figure 5-4. GPIO Pin Output Voltage vs Sinking Current

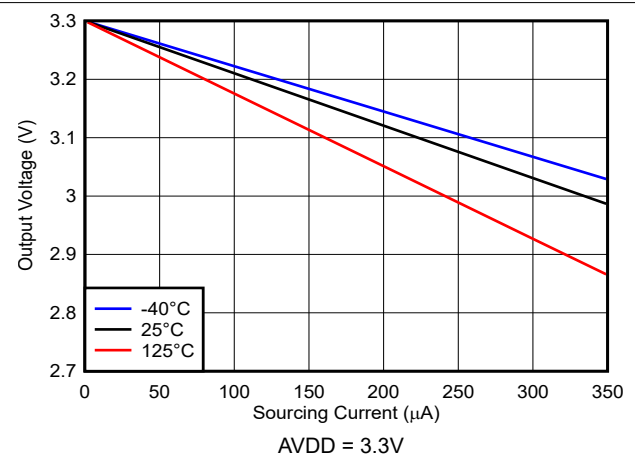

Figure 5-5. GPIO Pin Output Voltage vs Sourcing Current

## 6 Parameter Measurement Information

### 6.1 Noise Performance

Delta-sigma ( $\Delta\Sigma$ ) analog-to-digital converters (ADCs) are based on the principle of oversampling. The input signal of a  $\Delta\Sigma$  ADC is sampled at a high frequency (modulator frequency) and subsequently filtered and decimated in the digital domain to yield a conversion result at the respective output data rate. The ratio between modulator frequency and output data rate is called the oversampling ratio (OSR). By increasing the OSR, and thus reducing the output data rate, the noise performance of the ADC can be optimized. In other words, the input-referred noise drops when reducing the output data rate because more samples of the internal modulator are averaged to yield one conversion result. Increasing the gain also reduces the input-referred noise, which is particularly useful when measuring low-level signals.

Table 6-1 to Table 6-3 summarize the typical device noise performance at  $T_A = 25^\circ\text{C}$  using  $f_{\text{CLK}} = 4.096\text{MHz}$ . The data shown are typical input-referred noise results ( $e_n$ ) in units of  $\mu\text{V}_{\text{RMS}}$  with the analog inputs shorted together. A minimum of 1,000 consecutive conversions or 10 seconds of consecutive conversions (whichever occurs first) are used to measure RMS noise. Because of the statistical nature of noise, repeated noise measurements can yield higher or lower noise results.

Use Equation 1 or Equation 2 to calculate effective resolution from the provided  $\mu\text{V}_{\text{RMS}}$  numbers, depending on the selected coding scheme.

$$\text{Binary two's complement coding: Effective Resolution} = \ln[(2 \times V_{\text{REF}} / \text{Gain}) / e_{n(\text{RMS})}] / \ln(2) \quad (1)$$

$$\text{Unipolar straight binary coding: Effective Resolution} = \ln[(V_{\text{REF}} / \text{Gain}) / e_{n(\text{RMS})}] / \ln(2) \quad (2)$$

Input-referred noise ( $e_n$ ) in units of  $\mu\text{V}_{\text{PP}}$  can be estimated as  $e_{n(\text{PP})} = 6.6 \times e_{n(\text{RMS})}$ . Use Equation 3 or Equation 4 to calculate noise-free resolution from the estimated  $\mu\text{V}_{\text{PP}}$  numbers, depending on the selected coding scheme.

$$\text{Binary two's complement coding: Noise-free Resolution} = \ln[(2 \times V_{\text{REF}} / \text{Gain}) / e_{n(\text{PP})}] / \ln(2) \quad (3)$$

$$\text{Unipolar straight binary coding: Noise-free Resolution} = \ln[(V_{\text{REF}} / \text{Gain}) / e_{n(\text{PP})}] / \ln(2) \quad (4)$$

Input-referred noise performance using shorted inputs does only change insignificantly with the reference voltage. That is, Table 6-1 to Table 6-3 also apply to other reference voltage values.

In global-chop mode, the device averages two measurements of the ADC with the inputs swapped. Global-chop mode significantly reduces the input offset of the device, and reduces noise by a factor of  $\sqrt{2}$ .

Noise data is measured using the 24-bit version of the device. For the 16-bit device, clip the noise data at the LSB size.

**Table 6-1. Input-referred Noise in  $\mu\text{V}_{\text{RMS}}$ ,  
at AVDD = 3.3V, Global-Chop Mode Disabled, Internal 2.5V Reference, Gain = 0.5 to 8**

OSR	DATA RATE (SPS) <sup>(1)</sup>	GAIN					
		0.5	1	2	4	5	8
<b>SPEED MODE 0 (<math>f_{\text{MOD}} = 32\text{kHz}</math>)</b>							
1600	20	8.06	3.91	2.20	1.44	1.37	0.99
1280	25	8.44	4.36	2.46	1.51	1.50	1.10
1024	31.25	8.27	4.22	3.32	1.46	1.44	1.07
512	62.5	11.5	5.82	3.27	2.09	2.00	1.47
256	125	16.1	8.18	4.44	2.91	2.91	2.08
128	250	21.6	10.9	6.20	3.80	3.80	2.75
32	1000	33.1	16.5	9.24	5.80	5.80	4.13
16	2000	51.7	26.0	14.1	8.37	8.37	5.81
<b>SPEED MODE 1 (<math>f_{\text{MOD}} = 256\text{kHz}</math>)</b>							
12800	20	2.46	1.32	0.80	0.57	0.57	0.49
10240	25	2.64	1.41	0.82	0.61	0.59	0.54
1024	250	7.34	3.87	2.33	1.69	1.69	1.53
512	500	10.4	5.41	3.23	2.37	2.37	2.15
256	1000	14.4	7.44	4.51	3.31	3.31	2.98
128	2000	19.5	10.2	6.08	4.39	4.39	3.93
32	8000	29.4	15.2	9.10	6.56	6.56	5.76
16	16000	49.4	25.3	14.5	9.78	9.77	8.26
<b>SPEED MODE 2 (<math>f_{\text{MOD}} = 512\text{kHz}</math>)</b>							
25600	20	1.74	0.90	0.51	0.33	0.33	0.28
20480	25	1.85	0.99	0.55	0.35	0.35	0.30
1024	500	7.36	3.75	2.11	1.42	1.40	1.18
512	1000	10.2	5.16	2.93	1.97	1.97	1.65
256	2000	14.3	7.16	4.13	2.73	2.73	2.27
128	4000	19.3	9.82	5.55	3.66	3.65	3.04
32	16000	29.0	14.8	8.34	5.40	5.40	4.45
16	32000	49.4	25.1	13.6	8.31	8.31	6.48
<b>SPEED MODE 3 (<math>f_{\text{MOD}} = 1024\text{kHz}</math>)</b>							
51200	20	1.27	0.67	0.39	0.28	0.28	0.26
40960	25	1.36	0.70	0.41	0.30	0.30	0.27
1024	1000	7.43	3.86	2.27	1.64	1.63	1.55
512	2000	10.4	5.42	3.18	2.29	2.29	2.18
256	4000	14.5	7.47	4.43	3.17	3.17	3.02
128	8000	19.6	10.2	5.93	4.27	4.26	4.03
32	32000	29.5	15.2	8.89	6.31	6.30	5.93
16	64000	50.1	25.6	14.3	9.56	9.56	8.52

(1) Using  $f_{\text{CLK}} = 4.096\text{MHz}$

**Table 6-2. Input-referred Noise in  $\mu\text{V}_{\text{RMS}}$ ,  
at AVDD = 3.3V, Global-Chop Mode Disabled, Internal 2.5V Reference, Gain = 10 to 64**

OSR	DATA RATE (SPS) <sup>(1)</sup>	GAIN					
		10	16	20	32	50	64
<b>SPEED MODE 0 (<math>f_{\text{MOD}} = 32\text{kHz}</math>)</b>							
1600	20	1.02	0.57	0.57	0.42	0.41	0.33
1280	25	1.07	0.60	0.60	0.43	0.43	0.35
1024	31.25	1.06	0.61	0.58	0.44	0.44	0.34
512	62.5	1.44	0.84	0.79	0.61	0.61	0.48
256	125	2.08	1.15	1.13	0.80	0.80	0.65
128	250	2.75	1.57	1.54	1.11	1.11	0.91
32	1000	4.13	2.36	2.33	1.66	1.66	1.35
16	2000	5.81	3.25	3.25	2.30	2.30	1.80
<b>SPEED MODE 1 (<math>f_{\text{MOD}} = 256\text{kHz}</math>)</b>							
12800	20	0.49	0.31	0.31	0.28	0.28	0.16
10240	25	0.53	0.34	0.34	0.30	0.30	0.17
1024	250	1.51	0.97	0.97	0.87	0.87	0.49
512	500	2.12	1.33	1.31	1.25	1.25	0.68
256	1000	2.98	1.90	1.89	1.72	1.72	0.94
128	2000	3.88	2.42	2.41	2.18	2.16	1.19
32	8000	5.76	3.50	3.50	3.10	3.10	1.59
16	16000	8.26	4.97	4.96	4.37	4.36	2.21
<b>SPEED MODE 2 (<math>f_{\text{MOD}} = 512\text{kHz}</math>)</b>							
25600	20	0.28	0.19	0.19	0.16	0.15	0.10
20480	25	0.30	0.21	0.21	0.17	0.17	0.10
1024	500	1.18	0.82	0.82	0.69	0.69	0.43
512	1000	1.64	1.15	1.15	0.96	0.96	0.59
256	2000	2.27	1.59	1.59	1.37	1.37	0.83
128	4000	3.04	2.10	2.10	1.77	1.74	1.08
32	16000	4.45	3.03	3.03	2.50	2.49	1.55
16	32000	6.48	4.35	4.35	3.53	3.52	2.17
<b>SPEED MODE 3 (<math>f_{\text{MOD}} = 1024\text{kHz}</math>)</b>							
51200	20	0.26	0.17	0.17	0.16	0.16	0.09
40960	25	0.27	0.19	0.19	0.16	0.16	0.10
1024	1000	1.54	1.09	1.09	0.93	0.93	0.58
512	2000	2.17	1.54	1.54	1.31	1.31	0.80
256	4000	2.99	2.13	2.13	1.81	1.81	1.11
128	8000	4.03	2.83	2.83	2.41	2.37	1.48
32	32000	5.92	4.16	4.16	3.47	3.47	2.14
16	64000	8.50	5.92	5.91	4.91	4.91	3.02

(1) Using  $f_{\text{CLK}} = 4.096\text{MHz}$

**Table 6-3. Input-referred Noise in  $\mu\text{V}_{\text{RMS}}$ ,  
at AVDD = 3.3V, Global-Chop Mode Disabled, Internal 2.5V Reference, Gain = 100 to 256**

OSR	DATA RATE (SPS) <sup>(1)</sup>	GAIN			
		100	128	200	256
<b>SPEED MODE 0 (<math>f_{\text{MOD}} = 32\text{kHz}</math>)</b>					
1600	20	0.327	0.299	0.299	0.268
1280	25	0.347	0.310	0.308	0.305
1024	31.25	0.333	0.301	0.301	0.278
512	62.5	0.474	0.435	0.421	0.387
256	125	0.654	0.589	0.572	0.552
128	250	0.914	0.776	0.776	0.773
32	1000	1.349	1.190	1.187	1.117
16	2000	1.812	1.587	1.574	1.510
<b>SPEED MODE 1 (<math>f_{\text{MOD}} = 256\text{kHz}</math>)</b>					
12800	20	0.146	0.143	0.141	0.134
10240	25	0.164	0.152	0.152	0.141
1024	250	0.482	0.438	0.438	0.426
512	500	0.661	0.635	0.617	0.593
256	1000	0.944	0.900	0.857	0.822
128	2000	1.186	1.086	1.086	1.036
32	8000	1.593	1.441	1.441	1.350
16	16000	2.211	1.987	1.980	1.859
<b>SPEED MODE 2 (<math>f_{\text{MOD}} = 512\text{kHz}</math>)</b>					
25600	20	0.099	0.083	0.083	0.073
20480	25	0.102	0.086	0.084	0.079
1024	500	0.425	0.353	0.353	0.316
512	1000	0.589	0.507	0.505	0.440
256	2000	0.832	0.690	0.690	0.609
128	4000	1.080	0.902	0.896	0.782
32	16000	1.541	1.260	1.251	1.078
16	32000	2.167	1.747	1.746	1.489
<b>SPEED MODE 3 (<math>f_{\text{MOD}} = 1024\text{kHz}</math>)</b>					
51200	20	0.093	0.080	0.079	0.068
40960	25	0.101	0.085	0.083	0.074
1024	1000	0.576	0.484	0.474	0.414
512	2000	0.801	0.666	0.666	0.589
256	4000	1.114	0.929	0.929	0.804
128	8000	1.477	1.221	1.208	1.045
32	32000	2.140	1.742	1.742	1.490
16	64000	3.007	2.436	2.434	2.067

(1) Using  $f_{\text{CLK}} = 4.096\text{MHz}$

## 7 Detailed Description

### 7.1 Overview

The ADS1x2C14 are small, low-power, 16- and 24-bit,  $\Delta\Sigma$  ADCs that offer many integrated features to reduce system cost and component count in the most common sensor measurement applications. The devices are available in a 3mm × 3mm WQFN-16, as well as in a 1.87mm × 1.97mm DSBGA-16 package for extremely space-constrained applications.

Key integrated analog features include:

- A flexible input multiplexer which allows to select any of the eight analog inputs or GND as positive or negative input.
- A low-noise, high input-impedance PGA with programmable gain from 0.5 to 256.
  - Gain of 0.5 allows to measure signals which are larger than the selected reference voltage.
  - Single-ended measurements, where the negative input is connected to GND, are possible for gain settings between 0.5 and 10.
- A low-drift voltage reference programmable to 1.25V or 2.5V. A buffered version of the internal voltage reference is available on the REFOUT pin which can be used to bias external circuitry.
- One external, differential reference input with optional reference buffers that can be individually enabled and disabled.
- Two matched, sensor-excitation current sources (IDACs) which can be routed to any of the eight analog inputs to bias resistive sensors, such as thermistors, resistance temperature detectors (RTDs), or bridge sensors. Excitation currents between 1 $\mu$ A and 1mA can be programmed with fine granularity.
- A set of programmable burn-out current sources that are used for sensor fault detection.
- A low-drift 4.096MHz oscillator which establishes the device main clock. Alternatively an external clock can be provided.
- A linear temperature sensor.
- Analog supply and reference undervoltage monitors. Depending on the circuit implementation, the reference undervoltage monitor is especially helpful to detect open sensor conditions.
- Four general-purpose input/output pins (GPIOs) which are shared with analog inputs. Push-pull or open-drain output configurations can be individually selected for each general-purpose output. The GPIOs use logic levels based on the analog supply.

The devices also include a variety of digital features to accommodate a wide range of applications:

- Four speed modes allow to optimize the power consumption and noise performance for each application.
- Depending on the selected speed mode, output data rates from 20SPS up to 64kSPS can be achieved by adjusting the oversampling ratio (OSR) of the integrated digital filter. At output data rates of 20SPS and 25SPS, the digital filter offers simultaneous 50Hz and 60Hz line-cycle rejection with single-cycle settling.
- A global-chop mode which reduces offset and offset drift to a minimum.
- Selection between single-shot and continuous-conversion modes.
- An I<sup>2</sup>C-compatible serial interface to read conversion and register data, as well as to configure and control the device. Supported I<sup>2</sup>C-bus speeds: Standard-mode (Sm), Fast-mode (FM), and Fast-mode Plus (Fm+). The devices can be operated on an I<sup>3</sup>C bus.
- Eight pin-programmable I<sup>2</sup>C addresses.
- Data integrity features, such as I<sup>2</sup>C CRC, register map CRC, and internal memory CRC to detect communication faults and unintended bit flips.
- Selection between two output data coding schemes: binary two's complement and unipolar straight binary format. The unipolar straight binary format is beneficial for applications where the differential input signal is always positive.

## 7.2 Functional Block Diagram

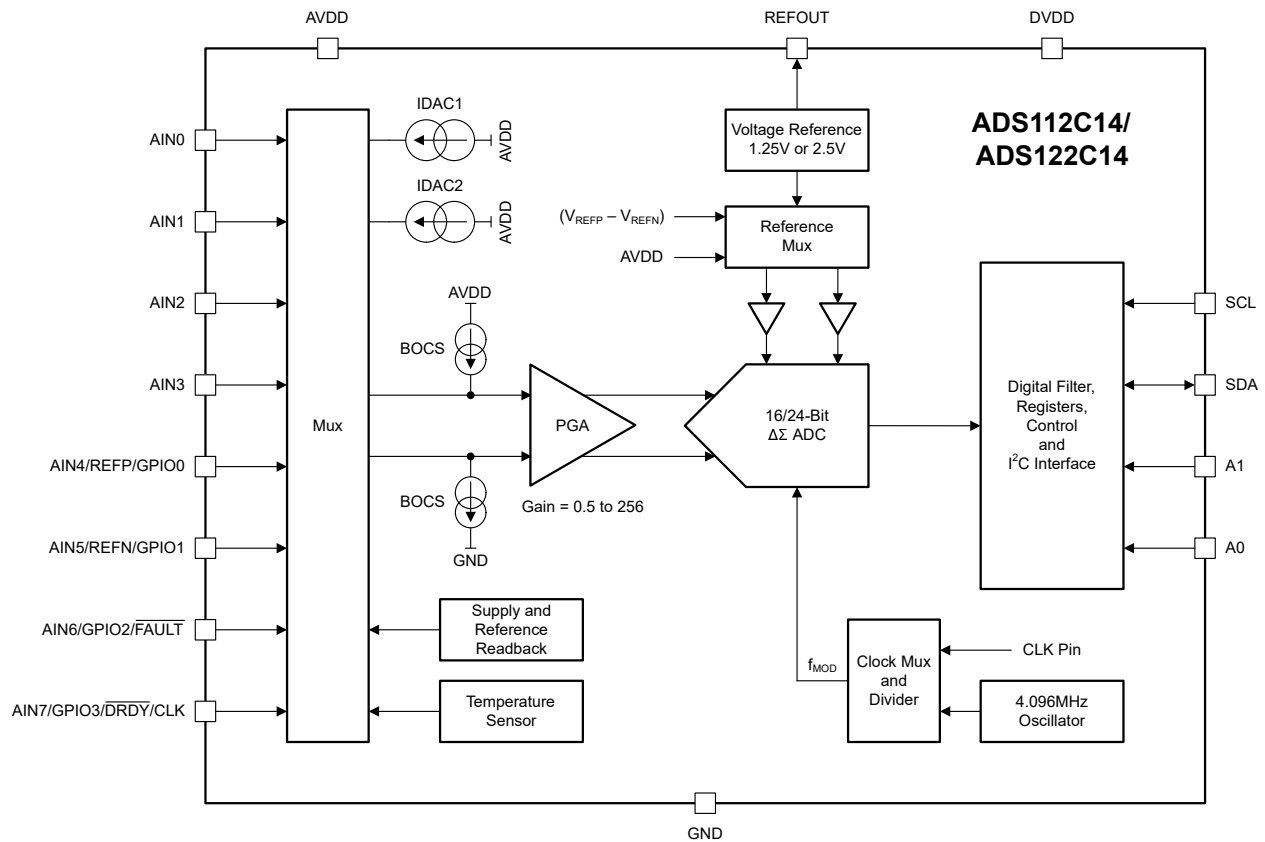

## 7.3 Feature Description

### 7.3.1 Analog Inputs and Multiplexer

The ADS1x2C14 contain a flexible input multiplexer; see [Figure 7-1](#). Select any of the eight analog inputs as the positive or negative input for the PGA using the AINP[3:0] and AINN[3:0] bits. In addition, an internal GND connection can be selected as the positive or negative PGA input.

The multiplexer also routes the two integrated excitation current sources to any of the eight analog input pins to bias resistive sensors (bridges, RTDs, and thermistors).

In addition, the ADS1x2C14 contain the following system monitor functions which can be selected for measurement through the multiplexer using the SYS\_MON[2:0] bits:

- The inputs of the PGA can be shorted together to mid-supply, ( $AVDD / 2$ ), to measure and calibrate the input offset of the internal signal chain.
- An integrated temperature sensor that provides an output signal proportional to the device temperature.
- The attenuated external reference voltage,  $(V_{REFP} - V_{REFN}) / 8$ .
- The attenuated analog and digital supplies,  $(AVDD / 8)$  and  $(DVDD / 8)$ , respectively.

Electrostatic discharge (ESD) diodes to AVDD and GND protect the inputs. To prevent the ESD diodes from turning on, the absolute voltage on any input must stay within the range provided by [Equation 5](#):

$$GND - 0.3V < V_{AINx} < AVDD + 0.3V \quad (5)$$

External Schottky clamp diodes or series resistors can be required to limit the input current to safe values (see the [Absolute Maximum Ratings](#) table). Overdriving an unselected input on the device can affect conversions taking place on other input pins.

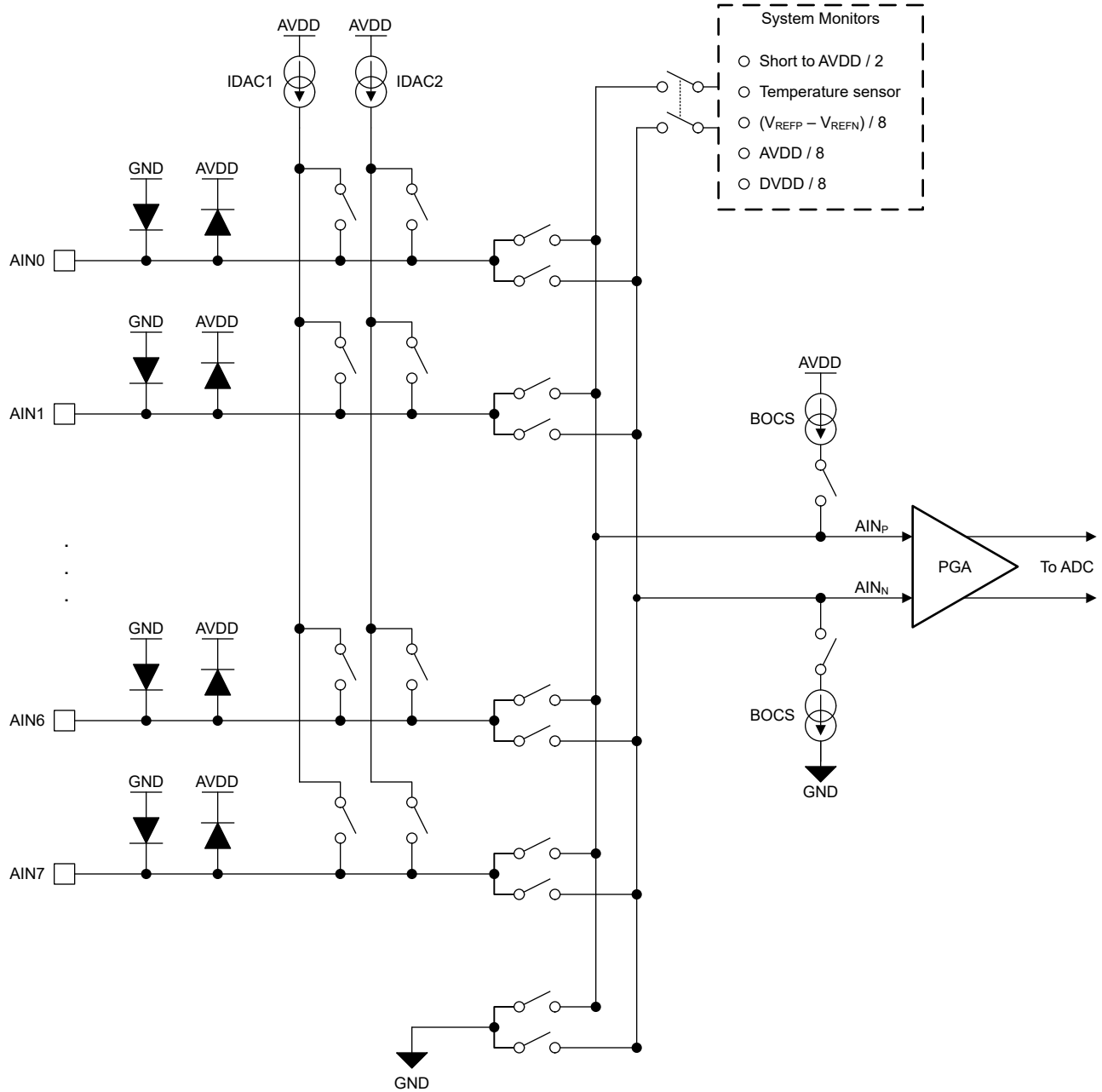

**Figure 7-1. Input Multiplexer**

### 7.3.2 Programmable Gain Amplifier (PGA)

The ADS1x2C14 integrate a low-drift, low-noise, high input impedance programmable gain amplifier (PGA). Use the GAIN[3:0] bits to configure the PGA for gains of 0.5, 1, 2, 4, 5, 8, 10, 16, 20, 32, 50, 64, 100, 128, 200, or 256. The full-scale input voltage range (FSR) of the PGA is defined by the gain setting, the reference voltage, and the conversion data coding setting, as shown in [Equation 6](#) and [Equation 7](#):

$$\text{Binary two's complement coding: FSR} = \pm V_{\text{REF}} / \text{Gain} \quad (6)$$

$$\text{Unipolar straight binary coding: FSR} = 0\text{V to } +V_{\text{REF}} / \text{Gain} \quad (7)$$

[Table 7-1](#) shows the corresponding nominal full-scale ranges using binary two's complement coding for a 1.25V and a 2.5V reference voltage, respectively.

**Table 7-1. PGA Full-Scale Range (Binary Two's Complement Coding)**

GAIN SETTING	$V_{\text{REF}} = 1.25\text{V}$	$V_{\text{REF}} = 2.5\text{V}$
0.5	$\pm 2.5\text{V}$	$\pm 5\text{V}$
1	$\pm 1.25\text{V}$	$\pm 2.5\text{V}$
2	$\pm 0.625\text{V}$	$\pm 1.25\text{V}$
4	$\pm 0.313\text{V}$	$\pm 0.625\text{V}$
5	$\pm 0.25\text{V}$	$\pm 0.5\text{V}$
8	$\pm 0.156\text{V}$	$\pm 0.313\text{V}$
10	$\pm 0.125\text{V}$	$\pm 0.25\text{V}$
16	$\pm 78.125\text{mV}$	$\pm 0.156\text{V}$
20	$\pm 62.5\text{mV}$	$\pm 0.125\text{V}$
32	$\pm 39.063\text{mV}$	$\pm 78.125\text{mV}$
50	$\pm 25\text{mV}$	$\pm 50\text{mV}$
64	$\pm 19.531\text{mV}$	$\pm 30.063\text{mV}$
100	$\pm 12.5\text{mV}$	$\pm 25\text{mV}$
128	$\pm 9.766\text{mV}$	$\pm 19.531\text{mV}$
200	$\pm 6.25\text{mV}$	$\pm 12.5\text{mV}$
256	$\pm 4.883\text{mV}$	$\pm 9.766\text{mV}$

Depending on the gain setting, the PGA has certain voltage headroom requirements to stay within the linear operating range that must be met for the selected positive and negative analog inputs as specified by the *absolute input voltage* parameter in the [Recommended Operating Conditions](#). Both the positive and negative PGA inputs need to stay within those voltage limits, even for FSR settings which in principle extend beyond those limits. For example, assume  $AV_{\text{DD}} = 3.3\text{V}$ , gain = 0.5,  $V_{\text{REF}} = 2.5\text{V}$ , unipolar coding scheme, and AINN connected to GND. In this case AINP needs to stay between 0V and  $(3.3\text{V} - 0.35\text{V}) = 2.95\text{V}$ . Therefore only a portion of the full code range (FSR = 0V to 5V) is utilized.

For gain settings 0.5 to 10, the devices allow single-ended measurements with the negative analog input held at GND. The negative analog input can be connected to GND externally using one of the analog inputs or the internal GND connection of the multiplexer in this case. The devices offer a unipolar, straight binary conversion data coding scheme that can be selected using the CODING bit. This coding scheme is beneficial for single-ended measurements, because the full code range is mapped to the 0V to  $+V_{\text{REF}} / \text{Gain}$  voltage range.

For gain settings 16 to 256 the PGA requires some voltage headroom from GND and  $AV_{\text{DD}}$  on both the positive and negative analog inputs.

The PGA remains active in idle mode, but turns off in standby and power-down mode.

### 7.3.3 Voltage Reference

The ADC requires a reference voltage for operation. The magnitude of the reference voltage together with the PGA gain setting establishes the ADC full-scale range. Use the REF\_SEL[1:0] bits to select from one of the following reference sources:

- Internal voltage reference
- External reference connected between the REFP and REFN pins ( $V_{REF} = V_{REFP} - V_{REFN}$ )
- Analog supply ( $V_{REF} = AVDD$ )

#### 7.3.3.1 Internal Reference

The devices integrate a precision, low-drift voltage reference. Select between a 1.25V and 2.5V reference voltage option using the REF\_VAL bit. When changing the REF\_VAL bit setting, allow at least 250 $\mu$ s for the device to switch the reference value before starting any conversions. The internal voltage reference requires a certain voltage headroom from the AVDD supply for operation as specified in the [Electrical Characteristics](#) table. Keep this headroom in mind when selecting the 2.5V reference value.

The internal reference is always enabled even when the external reference or the analog supply is selected as the reference source. The internal voltage reference only powers down in power-down mode.

The REFOUT pin provides a buffered version of the internal reference voltage. The REFOUT pin can both source and sink current to bias external circuitry. Connect a 100nF capacitor between REFOUT and GND. Larger capacitor values up to 1.3 $\mu$ F can be used to help filter more noise at the expense of a longer reference start-up time. The capacitor is required for the internal voltage reference stability, even when the REFOUT pin is not used to bias any external circuitry, and even when the external reference or the analog supply is selected as the reference source. Keep the reference settling time in mind after device power-up or when coming out of power-down mode before starting any conversions.

#### 7.3.3.2 External Reference

An external reference can be applied between the REFP and REFN pins ( $V_{REF} = V_{REFP} - V_{REFN}$ ). The differential reference input allows freedom in the reference common-mode voltage. However, the polarity of the reference voltage must be positive. Follow the requirements in the [Recommended Operating Conditions](#) for the absolute and differential reference input voltages.

The REFP and REFN inputs are combined with the AIN4 and AIN5 pins. AIN4 and AIN5 can still be used as analog inputs, even when the inputs are configured as external reference inputs.

#### 7.3.3.3 Reference Buffers

The devices provide two individually selectable reference input buffers to lower the reference input current. Use the REFP\_BUF\_EN and REFN\_BUF\_EN bits to enable or disable the positive and negative reference buffers respectively.

Disable the negative reference buffer when the external negative reference input (REFN) is at GND. Disable the positive reference buffer when the external positive reference input (REFP) is at AVDD. Disable both reference buffers when either the internal voltage reference or the analog supply is selected as the reference source.

The reference buffers remain active in idle mode, but turn off in standby and power-down mode.

### 7.3.4 Clock Source

The ADS1x2C14 require a main clock for operation. The main clock is provided in one of two ways:

- The internal low-drift 4.096MHz oscillator or
- An external clock on the CLK input pin

Use the CLK\_SEL bit to select the clock source. At device power-up or after device reset, the internal oscillator is selected as the clock source by default.

The external CLK input is combined with the AIN7/GPIO3 pin. To change from the internal oscillator to the external clock, first set GPIO3\_CFG = 01b to configure the GPIO3 pin as external clock input, then set CLK\_SEL = 1b.

The modulator clock for the delta-sigma ADC is derived from the main clock. A clock divider divides the main clock frequency ( $f_{CLK}$ ) by a division factor based on the selected speed mode to create the modulator frequency ( $f_{MOD} = f_{CLK} / DIV$ ). Table 7-2 shows the respective clock divider settings per speed mode together with the nominal modulator frequencies.

**Table 7-2. Clock Divider Settings**

SPEED MODE	CLOCK DIVIDER (DIV)	MODULATOR FREQUENCY ( $f_{MOD}$ ) <sup>(1)</sup>
0	128	32kHz
1	16	256kHz
2	8	512kHz
3	4	1.024MHz

(1) Using a nominal clock frequency of  $f_{CLK} = 4.096\text{MHz}$ .

### 7.3.5 Delta-Sigma Modulator

The ADS1x2C14 use an inherently stable, third-order, delta-sigma modulator. The modulator samples the analog input voltage at the modulator frequency ( $f_{MOD} = 1 / t_{MOD}$ ) and converts the analog input to a ones-density bitstream representing the ratio between the input signal and the reference voltage. The modulator shapes the noise of the converter to high frequency, where the noise is removed by the digital filter.

### 7.3.6 Digital Filter

The delta-sigma modulator bitstream feeds into a digital filter. The digital filter low-pass filters and decimates the low-resolution, high-speed modulator output to produce high-resolution ADC data at an output data rate of  $f_{DATA}$ . The decimation factor, defined as per Equation 8, is called the oversampling ratio (OSR).

$$OSR = f_{MOD} / f_{DATA} \quad (8)$$

The OSR determines the amount of averaging that is applied to the modulator output in the digital filter and, therefore, the filter bandwidth and conversion noise. Higher OSRs lead to lower filter bandwidth and better noise performance.

Use the FLTR\_OS[2:0] bits to select the OSR and to select between the following digital filter types:

- Sinc4 filter for OSRs 16 and 32
- Sinc4 filter followed by a Sinc1 filter for OSRs 128 to 1024
- Finite impulse response (FIR) filter with speed-mode independent data rate options of 20SPS and 25SPS, which offers simultaneous 50Hz and 60Hz line-cycle rejection

Figure 7-2 shows the digital filter architecture.

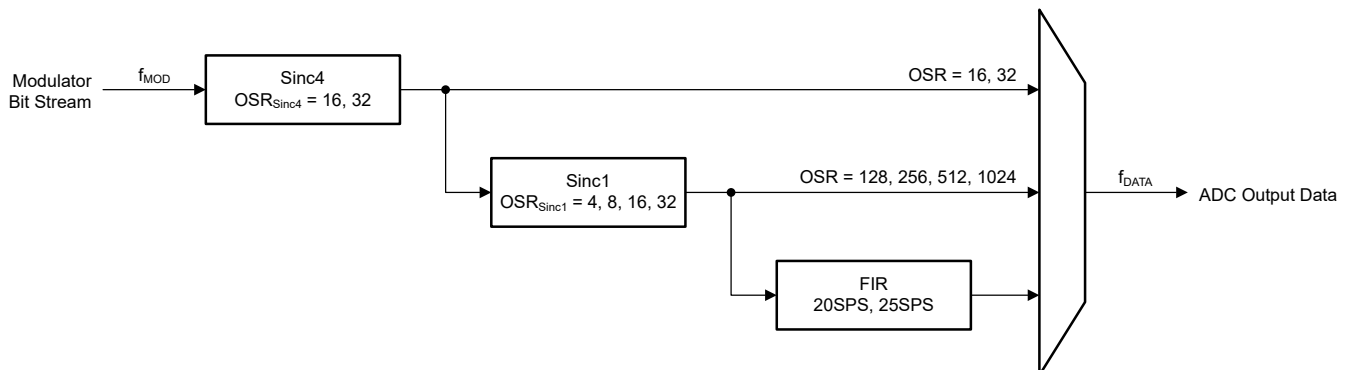

**Figure 7-2. Digital Filter Architecture**

### 7.3.6.1 Sinc4 and Sinc4 + Sinc1 Filter

The Sinc filter path is made up of one or two stages based on the FLTR\_OSR[2:0] setting as shown in [Figure 7-2](#). For OSR settings 16 and 32, a pure Sinc4 filter is used. For OSR settings 128 to 1024, the Sinc4 filter operates at an OSR = 32, and is followed by a Sinc1 filter stage with OSRs selectable between 4, 8, 16, and 32. [Table 7-3](#) provides an overview of the Sinc filter configurations based on the FLTR\_OSR[2:0] setting.

**Table 7-3. Sinc Filter OSR Settings**

FLTR_OSR[2:0]	SINC4 OSR	SINC1 OSR	OVERALL OSR
000b	16	–	16
001b	32	–	32
010b	32	4	128
011b	32	8	256
100b	32	16	512
101b	32	32	1024

[Table 7-4](#) provides an overview of the resulting output data rates for the various speed modes based on the OSR setting. The data rates scale with  $f_{CLK}$ .

**Table 7-4. Sinc Filter Output Data Rates**

OSR	–3dB Frequency	OUTPUT DATA RATE ( $f_{DATA}$ ) <sup>(1)</sup>			
		SPEED MODE 0 ( $f_{MOD} = 32\text{kHz}$ )	SPEED MODE 1 ( $f_{MOD} = 256\text{kHz}$ )	SPEED MODE 2 ( $f_{MOD} = 512\text{kHz}$ )	SPEED MODE 3 ( $f_{MOD} = 1.024\text{MHz}$ )
16	$0.228 \times f_{DATA}$	2kSPS	16kSPS	32kSPS	64kSPS
32	$0.228 \times f_{DATA}$	1kSPS	8kSPS	16kSPS	32kSPS
128	$0.410 \times f_{DATA}$	250SPS	2kSPS	4kSPS	8kSPS
256	$0.434 \times f_{DATA}$	125SPS	1kSPS	2kSPS	4kSPS
512	$0.440 \times f_{DATA}$	62.5SPS	500SPS	1kSPS	2kSPS
1024	$0.442 \times f_{DATA}$	31.25SPS	250SPS	500SPS	1kSPS

(1) Based on a nominal clock frequency of  $f_{CLK} = 4.096\text{MHz}$

The frequency response of the combined Sinc4 + Sinc1 filter is given by [Equation 9](#). For the pure Sinc4 filter frequency response ignore the second term in the equation.

$$|H(f)| = \left| \frac{\sin\left[\frac{A\pi f}{f_{MOD}}\right]}{A \sin\left[\frac{\pi f}{f_{MOD}}\right]} \right|^4 \cdot \left| \frac{\sin\left[\frac{B\pi f}{f_{MOD}}\right]}{B \sin\left[\frac{\pi f}{f_{MOD}}\right]} \right| \quad (9)$$

where:

- $f$  = Signal frequency
- $f_{MOD}$  = Modulator frequency
- $A$  = Sinc4 filter OSR
- $B$  = Sinc1 filter OSR

[Figure 7-3](#) to [Figure 7-6](#) show the filter frequency responses of the Sinc filters normalized to the output data rate. A Sinc filter has infinite attenuation at integer multiples of the output data rate except for integer multiples of  $f_{MOD}$ , as shown in [Figure 7-4](#). As with all digital filters, the digital filter response repeats at integer multiples of the modulator frequency,  $f_{MOD}$ . The data rate and filter notch frequencies scale with  $f_{MOD}$ .

The –3dB frequencies for the various Sinc filter configurations are given in [Table 7-4](#).

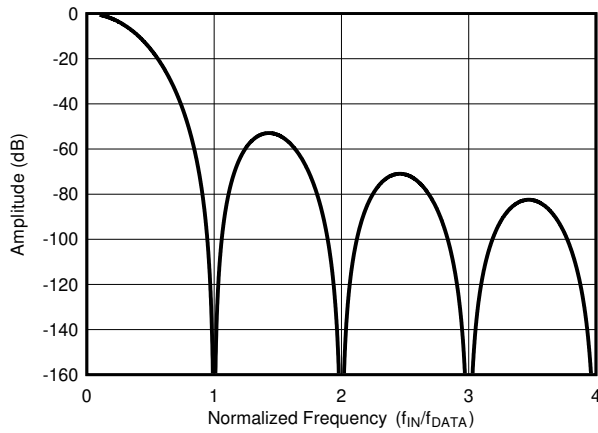

Figure 7-3. Sinc4 Frequency Response

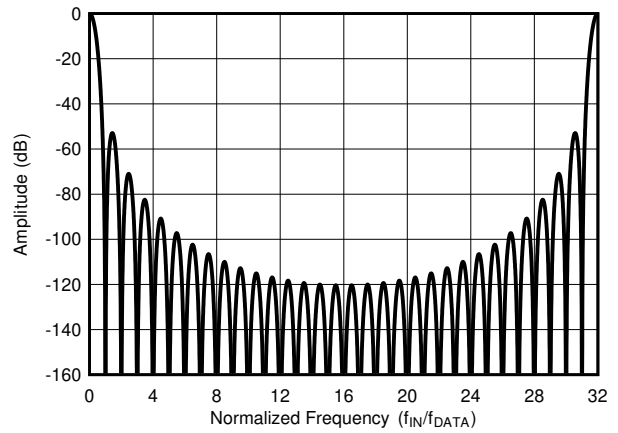

Figure 7-4. Sinc4 Frequency Response to  $f_{MOD}$  (OSR = 32)

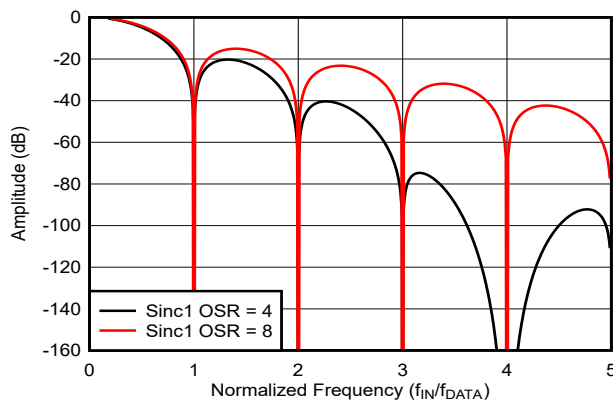

Figure 7-5. Sinc4 + Sinc1 Frequency Response (Sinc4 OSR = 32)

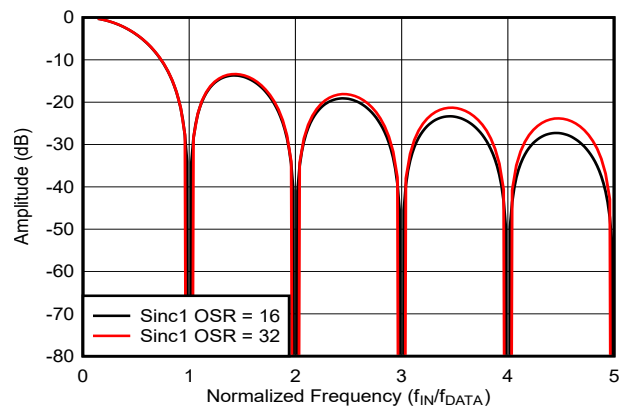

Figure 7-6. Sinc4 + Sinc1 Frequency Response (Sinc4 OSR = 32)

### 7.3.6.2 FIR Filter

In addition to the Sinc filters, the devices also provide two FIR filter options which offer simultaneous 50Hz and 60Hz line-cycle rejection. Select between a 20SPS and 25SPS data rate option using the FLTR\_OSRR[2:0] bits. The FIR filter adjusts the OSR based on the selected speed mode to provide data rates of 20SPS and 25SPS in all four speed modes as shown in Table 7-5.

Table 7-5. FIR Filter OSR Settings

OUTPUT DATA RATE <sup>(1)</sup>	-3dB Frequency	OSR			
		SPEED MODE 0 ( $f_{MOD} = 32\text{kHz}$ )	SPEED MODE 1 ( $f_{MOD} = 256\text{kHz}$ )	SPEED MODE 2 ( $f_{MOD} = 512\text{kHz}$ )	SPEED MODE 3 ( $f_{MOD} = 1.024\text{MHz}$ )
20SPS	13.2Hz	1600	12800	25600	51200
25SPS	15.1Hz	1280	10240	20480	40960

(1) Based on a nominal clock frequency of  $f_{CLK} = 4.096\text{MHz}$

Figure 7-7 to Figure 7-10 show the filter frequency responses for the two FIR filter configurations. The -3dB frequencies for the two FIR filters are given in Table 7-5.

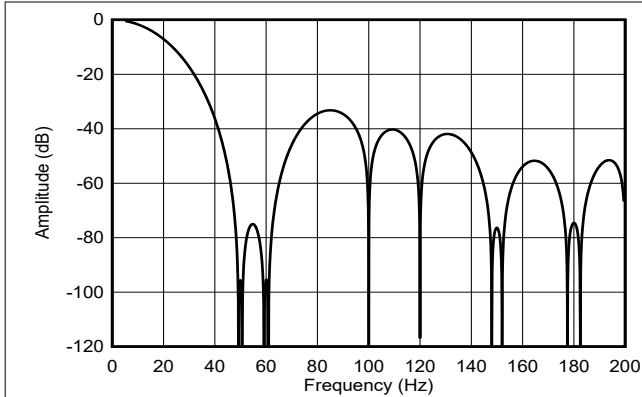

Figure 7-7. 20SPS Frequency Response

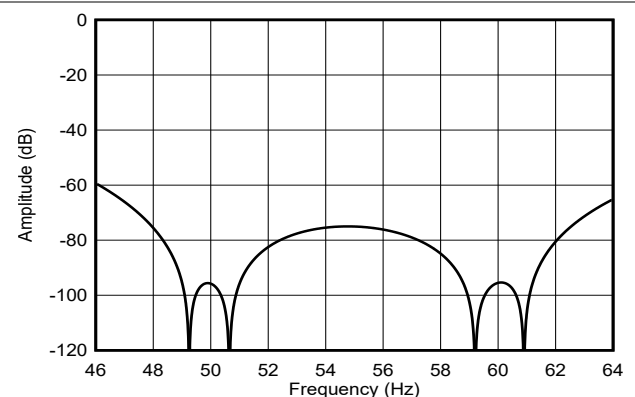

Figure 7-8. 20SPS Frequency Response (Zoomed)

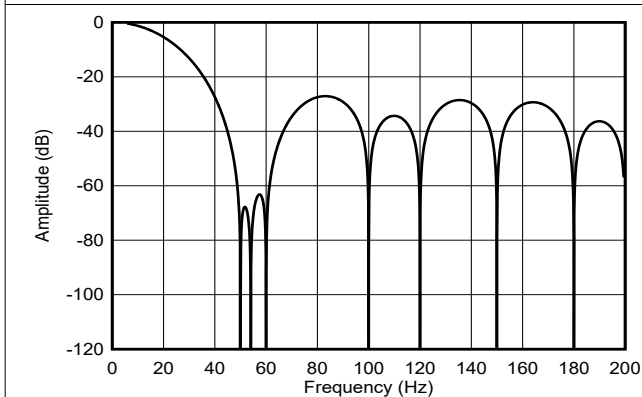

Figure 7-9. 25SPS Frequency Response

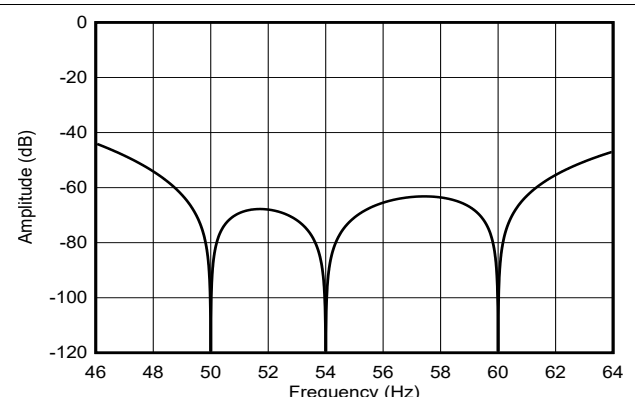

Figure 7-10. 25SPS Frequency Response (Zoomed)

### 7.3.6.3 Digital Filter Latency

When starting or restarting conversions, the digital filter resets and requires a certain amount of time to provide settled output data. This time is called the latency time,  $t_{\text{LATENCY}}$ . The ADS1x2C14 hides the unsettled data internally and only indicate when settled conversion data are available, by means of a falling  $\overline{\text{DRDY}}$  edge or the DRDY bit. Table 7-6 and Table 7-7 summarize the latency times for the various speed modes and digital filter settings. The latency times are measured from the rising SCL edge of the ACK bit after the CONVERSION\_CTRL register is written in idle mode, to the first falling  $\overline{\text{DRDY}}$  edge. Because the SCL rising edge in the SCL clock domain is latched by the digital filter logic running on the modulator clock domain, the latency times provided have an uncertainty of  $\pm 1 t_{\text{MOD}}$ . The conversion period for the second and all subsequent conversions equals  $t_{\text{DATA}} = 1 / f_{\text{DATA}} = \text{OSR} / f_{\text{MOD}}$  as shown in Figure 7-11.

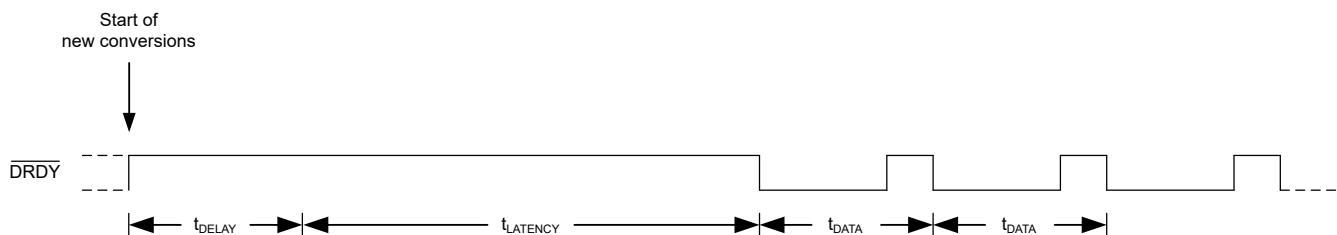

Figure 7-11. Latency Time and Conversion Period

The latency time increases in certain situations:

- when starting conversions from standby mode: adds  $5 t_{\text{MOD}}$  (Speed Mode 0),  $27 t_{\text{MOD}}$  (Speed Modes 1 and 2),  $35 t_{\text{MOD}}$  (Speed Mode 3)
- when restarting ongoing conversions by writing to a register which restarts conversions: adds  $6 t_{\text{MOD}}$

In addition, a programmable delay time can be added to delay the start of the conversion cycle after the START bit is set. This delay time allows for settling of external components, such as the voltage reference after exiting standby mode, or for additional settling time when switching the signal through the multiplexer. The delay time is only added to the first conversion after a conversion start as shown in Figure 7-11. Subsequent conversions are not delayed. Use the DELAY[3:0] bits to configure the delay time.

**Table 7-6. Sinc Filter Latency**

OSR	LATENCY IN $t_{MOD}$ <sup>(1)</sup> (ABSOLUTE TIME <sup>(2)</sup> )			
	SPEED MODE 0 ( $f_{MOD} = 32\text{kHz}$ )	SPEED MODE 1 ( $f_{MOD} = 256\text{kHz}$ )	SPEED MODE 2 ( $f_{MOD} = 512\text{kHz}$ )	SPEED MODE 3 ( $f_{MOD} = 1.024\text{MHz}$ )
16	80 (2.5ms)	88 (344 $\mu\text{s}$ )	88 (172 $\mu\text{s}$ )	104 (102 $\mu\text{s}$ )
32	144 (4.5ms)	152 (594 $\mu\text{s}$ )	152 (297 $\mu\text{s}$ )	168 (164 $\mu\text{s}$ )
128	240 (7.5ms)	248 (969 $\mu\text{s}$ )	248 (484 $\mu\text{s}$ )	264 (258 $\mu\text{s}$ )
256	368 (11.5ms)	376 (1.47ms)	376 (734 $\mu\text{s}$ )	392 (383 $\mu\text{s}$ )
512	624 (19.5ms)	632 (2.47ms)	632 (1.23ms)	648 (633 $\mu\text{s}$ )
1024	1136 (35.5ms)	1144 (4.47ms)	1144 (2.23ms)	1160 (1.13ms)

- (1)  $t_{MOD} = 1 / f_{MOD}$ . Latency time is measured when starting conversions from idle mode.
- (2) Based on a nominal clock frequency of  $f_{CLK} = 4.096\text{MHz}$ .

**Table 7-7. FIR Filter Latency**

OUTPUT DATA RATE	LATENCY IN $t_{MOD}$ <sup>(1)</sup> (ABSOLUTE TIME <sup>(2)</sup> )			
	SPEED MODE 0 ( $f_{MOD} = 32\text{kHz}$ )	SPEED MODE 1 ( $f_{MOD} = 256\text{kHz}$ )	SPEED MODE 2 ( $f_{MOD} = 512\text{kHz}$ )	SPEED MODE 3 ( $f_{MOD} = 1.024\text{MHz}$ )
20SPS	1736 (54.25ms)	12944 (50.56ms)	25744 (50.28ms)	51360 (50.16ms)
25SPS	1416 (44.25ms)	10384 (40.56ms)	20624 (40.28ms)	41120 (40.16ms)

- (1)  $t_{MOD} = 1 / f_{MOD}$ . Latency time is measured when starting conversions from idle mode.
- (2) Based on a nominal clock frequency of  $f_{CLK} = 4.096\text{MHz}$ .

**7.3.6.4 Global-Chop Mode**

The signal chain of the ADS1x2C14 uses a very low-drift, chopper-stabilized PGA and delta-sigma modulator to provide very low offset error and offset drift. However, a small amount of offset drift remains in normal measurement. For that reason, the devices incorporate an optional global-chop mode to reduce offset error and offset drift over both temperature and time to exceptionally low levels. When the global-chop mode is enabled by setting the GC\_EN bit, the device performs two consecutive conversions with alternate input signal polarity to cancel offset error. The first conversion is taken with normal input polarity. The global-chop control logic inverts the input polarity and resets the digital filter for the second conversion. The average of the two conversions yields the final offset-corrected result. Figure 7-12 illustrates a block diagram of the global-chop implementation.  $V_{OFS}$  models the combined PGA and ADC internal offset voltage. Only this device-inherent offset voltage is reduced by the global-chop mode. Any offset in the external circuitry connected to the analog inputs is not affected by global-chop mode.

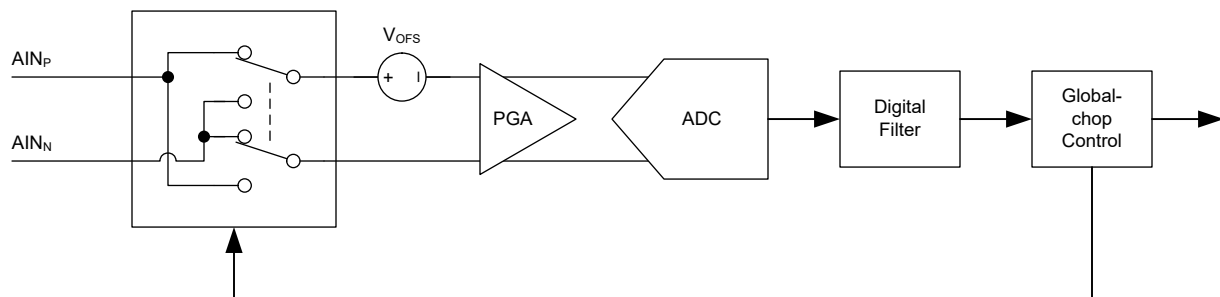

**Figure 7-12. Global-Chop Mode Control Diagram**

The operational sequence of global-chop mode is as follows:

- Conversion C1:  $V_{AINP} - V_{AINN} - V_{OFS} \rightarrow$  First conversion withheld after conversion start
- Conversion C2:  $V_{AINN} - V_{AINP} - V_{OFS} \rightarrow$  Output 1 =  $(V_{C1} - V_{C2}) / 2 = V_{AINP} - V_{AINN}$
- Conversion C3:  $V_{AINP} - V_{AINN} - V_{OFS} \rightarrow$  Output 2 =  $(V_{C3} - V_{C2}) / 2 = V_{AINP} - V_{AINN}$
- ...

The first conversion result (Output 1) after a conversion start is available after the device performed two settled conversions. Equation 10 calculates the time required to output the first conversion result after a conversion start.

In continuous-conversion mode with global-chop mode enabled, subsequent conversions complete in  $t_{GC\_DATA}$ , as calculated by Equation 11.

$$t_{GC\_LATENCY} = 2 \times (t_{DELAY} + t_{LATENCY}) - 12 t_{MOD} \quad (10)$$

$$t_{GC\_DATA} = t_{DELAY} + t_{LATENCY} - 12 t_{MOD} \quad (11)$$

Where:

- $t_{LATENCY}$  is the latency time given in Table 7-6 and Table 7-7
- $t_{DELAY}$  is the delay time programmable through the DELAY[3:0] bits

The device waits the programmable delay time after inverting the input polarity before starting the next conversion, to allow for the internal circuitry to settle. In some cases, the programmable delay time must be increased to allow for settling of external components.

Global-chop mode reduces the ADC noise by a factor of  $\sqrt{2}$  because two conversions are averaged. Divide the input-referred noise values in Table 6-1 to Table 6-3 by  $\sqrt{2}$  to derive the noise performance when global-chop mode is enabled.

The digital filter notches do not change in global-chop mode. However, additional filter notches appear at multiples of  $f_{GC\_DATA} / 2$ .

### 7.3.7 Excitation Current Sources (IDACs)

The devices incorporate two programmable, matched current sources (IDAC1 and IDAC2). The current sources provide excitation current to resistive temperature devices (RTDs), thermistors, diodes, and other resistive sensors that require constant current biasing. Each current source is independently programmable to output values between 1 $\mu$ A to 1mA.

Use the I1MAG[3:0] and I2MAG[3:0] bits in combination with the IUNIT bit to set the desired output current for each IDAC. The IUNIT bit sets the base current for both IDAC1 and IDAC2 to either 1 $\mu$ A or 10 $\mu$ A. The I1MAG[3:0] and I2MAG[3:0] bits act as multipliers of that base current to configure the individual IDAC1 and IDAC2 output currents.

Best matching between current sources is achieved when both IDACs are set to the same current value. In three-wire RTD applications, the matched current sources can be used to cancel errors caused by sensor lead resistance (see the [Software-Configurable RTD Measurement Input](#) section for more details).

Each current source can be routed to any of the analog inputs AINx using the I1MUX[2:0] and I2MUX[2:0] bits. Both current sources can also be combined onto the same pin by setting I1MUX[2:0] and I2MUX[2:0] to the same bit values, if excitation current values up to 2mA are required. Analog inputs AIN3 to AIN7 can be configured as analog inputs, reference inputs, or GPIOs irrespective of the IDAC routing. A pin that is selected as a current source output can still be used as an analog or reference input at the same time. However, note that the IDAC current causes a voltage drop along the internal signal trace of the analog or reference input path which leads to an offset that needs to be taken into consideration. Figure 7-1 shows the IDAC connections through the input multiplexer.

The current sources require voltage headroom to the AVDD supply to operate. This voltage headroom is also called the compliance voltage. When driving resistive loads, take care not to exceed the compliance voltage of

the IDACs, otherwise the specified accuracy of the IDAC current is not always met. For the IDAC compliance voltage specifications, see the [Electrical Characteristics](#) table.

The IDACs remain active in idle mode, but turn off in standby and power-down mode.

### 7.3.8 Burn-Out Current Sources (BOCS)

To help detect potential sensor faults, the ADS1x2C14 provide a pair of programmable burn-out current sources (BOCS). Use the BOCS[1:0] bits to enable the current sources and to set the values to 0.2 $\mu$ A, 1 $\mu$ A, or 10 $\mu$ A.

The BOCS connect to the PGA inputs after the internal multiplexer. When enabled, one BOCS sources current from AVDD to the selected positive analog input (AINP) and the other BOCS sinks current from the selected negative analog input (AINN) to GND.

In case of an open-circuit in the external sensor or a sensor wire disconnection, these BOCS pull the positive input toward AVDD and the negative input toward GND, resulting in a full-scale reading. A full-scale reading can also indicate that the sensor is overloaded or that the reference voltage is absent. A near-zero reading can indicate a shorted sensor. Distinguishing a shorted sensor condition from a normal reading can be difficult, especially if an RC filter is used at the inputs. The voltage drop across the external filter resistance and the residual resistance of the internal multiplexer created by the current sources can cause the ADC output to read a value larger than zero.

The ADC readings of a functional sensor can be corrupted when the burn-out current sources are enabled. Therefore, disable the burn-out current sources when performing precision measurements, and only enable the BOCS to test for sensor fault conditions during a dedicated diagnostic measurement.

Disable the BOCS when using global-chop mode (GC\_EN = 1b). The burn-out current source function is not compatible with global-chop mode.

The burn-out current sources remain active in idle mode, but turn off in standby and power-down mode.

### 7.3.9 General Purpose IOs (GPIOs)

The ADS1x2C14 provide four analog inputs (AIN4 to AIN7) that can be configured as general purpose inputs and outputs (GPIOs). The logic levels of those GPIOs are referenced to the AVDD supply. Use the GPIOx\_CFG[1:0] (x = 0 to 3) bits to configure the pins as either analog inputs, digital inputs or digital outputs with either push-pull or open-drain characteristic.

Set the digital output levels of the GPIOs using the GPIOx\_DAT\_OUT bits. The GPIOx\_DAT\_OUT bit setting has no effect when GPIOx is configured as an analog or digital input.

The GPIOx\_DAT\_IN bits indicate the readback values at the GPIOx pins irrespective if the pins are configured as digital inputs or outputs. The GPIOx\_DAT\_IN bits read back 0b when GPIOx is configured as an analog input.

In addition, the following special functions are available:

- GPIO2 can be configured as a  $\overline{\text{FAULT}}$  indication output.
- GPIO3 can be configured as a dedicated  $\overline{\text{DRDY}}$  output.
- GPIO3 can be configured as an external clock input. See the [Clock Source](#) section for details.

#### 7.3.9.1 $\overline{\text{FAULT}}$ Output

Configure GPIO2 as a  $\overline{\text{FAULT}}$  output by setting GPIO2\_CFG = 10b or 11b and GPIO2\_SRC = 1b. The  $\overline{\text{FAULT}}$  pin is low when any of the AVDD\_UVn, REF\_UVn, REG\_MAP\_CRC\_FAULTn, or MEM\_FAULTn status bits are 0b to indicate a fault. Connect a pulldown resistor from GPIO2 to GND to also detect potential device resets because the pin reverts back to a high-Z analog input during and after reset.

Use the FAULT\_PIN\_BEHAVIOR bit to select from the following  $\overline{\text{FAULT}}$  output behaviors:

- Static output. The  $\overline{\text{FAULT}}$  output is low when a fault occurred, otherwise the output is high.
- Heart beat output. The  $\overline{\text{FAULT}}$  output is low when a fault occurred, otherwise the output is a 50% duty-cycle signal with a frequency of  $f_{\text{MOD}} / 256$ . The heart beat signal frequency can be monitored by the host to detect potential device clock faults.

### 7.3.9.2 $\overline{\text{DRDY}}$ Output

Configure GPIO3 as a dedicated  $\overline{\text{DRDY}}$  output by setting GPIO3\_CFG = 10b or 11b and GPIO3\_SRC = 1b. A falling edge on the  $\overline{\text{DRDY}}$  pin indicates the completion of new conversion data.

### 7.3.10 System Monitors

The devices offer a set of system monitoring functions which can be routed to the PGA inputs internally for measurement through the input multiplexer. Use the SYS\_MON[2:0] bits to select from one of the following system monitors:

- The inputs of the PGA can be shorted together to mid-supply, (AVDD / 2), to measure and calibrate the input offset of the internal signal chain.
- An integrated temperature sensor that provides an output signal proportional to the device temperature.
- The attenuated external reference voltage,  $(V_{\text{REFP}} - V_{\text{REFN}}) / 8$ .
- The attenuated analog and digital supplies, (AVDD / 8) and (DVDD / 8), respectively.

The AINP[3:0] and AINN[3:0] bits have no effect and the analog inputs are disconnected from the PGA when one of the system monitors is selected. The internal reference with the value set by the REF\_VAL bit is automatically selected for SYS\_MON[2:0] settings 010b to 101b irrespective of the REF\_SEL[1:0] bit setting. Select an appropriate PGA gain setting for the respective measurement.

#### 7.3.10.1 Internal Short (Offset Calibration)

The system monitor offers the option to short both PGA inputs (AINP and AINN) to mid-supply (AVDD / 2). This option can be used to measure and calibrate the device offset by storing the result of the shorted input voltage reading in a microcontroller and consequently subtracting the result from each following reading. Take multiple readings with the inputs shorted and average the result to reduce the effect of noise.

#### 7.3.10.2 Internal Temperature Sensor

The ADS1x2C14 provide an integrated temperature sensors (TS) to measure the die temperature. The temperature sensor outputs a voltage that is proportional to the die temperature. The output voltage characteristic ( $TS_{\text{Offset}}$ ,  $TS_{\text{TC}}$ ) of the temperature sensor is specified in the [Electrical Characteristics](#) table.

Equation 12 shows how to convert the measured temperature sensor output voltage to die temperature:

$$\text{Die temperature } [^{\circ}\text{C}] = 25^{\circ}\text{C} + (\text{Measured voltage} - TS_{\text{Offset}}) / TS_{\text{TC}} \quad (12)$$

Select a gain setting for the PGA so that the maximum temperature sensor output voltage that can occur in the application is smaller than  $V_{\text{REF}} / \text{Gain}$ .

#### 7.3.10.3 External Reference Voltage Readback

The system monitor allows to monitor the external voltage reference connected between the REFP and REFN pins. For this purpose, select the attenuated external reference voltage,  $(V_{\text{REFP}} - V_{\text{REFN}}) / 8$  for measurement.

#### 7.3.10.4 Power-Supply Readback

The system monitor allows to monitor both the analog and digital supplies. For this purpose, select either the attenuated analog supply (AVDD / 8) or the attenuated digital supply (DVDD / 8) for measurement.

### 7.3.11 Monitors and Status Flags

The ADS1x2C14 provide a set of monitors with corresponding status flags to detect and indicate specific device or system faults to the host. [Table 7-8](#) provides an overview of the available monitors. Some monitors need to be enabled using a dedicated monitor enable bit. The monitor fault flags are available in the STATUS\_MSB register for readout. If a monitor detects a fault, the according low-active fault flag is set to 0b immediately, even when no conversions are ongoing.

**Table 7-8. Monitor Overview**

MONITOR NAME	MONITOR ENABLE BIT	MONITOR FAULT FLAG	FAULT FLAG RESET MECHANISM
Reset	N/A	RESETE <sub>n</sub>	Write 1b to clear bit to 1b
AVDD undervoltage	N/A	AVDD_UV <sub>n</sub>	Write 1b to clear bit to 1b
Reference undervoltage	REV_UV_EN	REF_UV <sub>n</sub>	Write 1b to clear bit to 1b
Register Map CRC	REG_MAP_CRC_EN	REG_MAP_CRC_FAULT <sub>n</sub>	Write 1b to clear bit to 1b
Memory Map CRC	N/A	MEM_FAULT <sub>n</sub>	Reset or power-cycle the device
Register Write Fault	N/A	REG_WRITE_FAULT <sub>n</sub>	Updates with the next register write command

In addition to the monitors, a data ready indication bit (DRDY) is available in the STATUS\_MSB register, and a 4-bit conversion counter in the STATUS\_LSB register.

Instead of reading the STATUS\_MSB or STATUS\_LSB registers on demand using a register read command, the devices can output a STATUS header as the first two bytes of every conversion data read. Enable the STATUS header transmission using the STATUS\_EN bit. The 16-bit STATUS header is a concatenation of the STATUS\_MSB[7:0] and STATUS\_LSB[7:0] register bits.

#### 7.3.11.1 Reset (RESETE<sub>n</sub> flag)

The RESETE<sub>n</sub> flag indicates if a device reset happened since the last time the bit was cleared to 1b. Write 1b to clear the RESETE<sub>n</sub> bit to 1b.

#### 7.3.11.2 AVDD Undervoltage Monitor (AVDD\_UV<sub>n</sub> flag)

The AVDD undervoltage monitor detects if the analog supply dropped below the AVDD undervoltage threshold (TH<sub>AVDD\_UV</sub>). Write 1b to clear the AVDD\_UV<sub>n</sub> bit to 1b.

The AVDD undervoltage monitor is always active, except in power-down mode. AVDD\_UV<sub>n</sub> sets to 0b when entering power-down mode even when the AVDD supply did not drop below the AVDD undervoltage threshold. The AVDD\_UV<sub>n</sub> bit can set to 0b unintentionally when changing the internal voltage reference value using the REF\_VAL bit.

The device does not reset when the analog supply drops below the AVDD threshold as long as the DVDD supply is still present.

#### 7.3.11.3 Reference Undervoltage Monitor (REV\_UV<sub>n</sub> flag)

The reference undervoltage monitor detects if the reference voltage selected by the REF\_SEL[1:0] bits dropped below the reference undervoltage threshold (TH<sub>REF\_UV</sub>). Enable the reference undervoltage monitor using the REF\_UV\_EN bit. However, the reference undervoltage monitor is inactive in standby and power-down mode irrespective of the REF\_UV\_EN bit setting. The REF\_UV<sub>n</sub> bit can set to 0b unintentionally, when enabling the reference undervoltage monitor, when changing the reference voltage source, or when coming out of power-down or standby mode. Write 1b to clear the REF\_UV<sub>n</sub> bit to 1b.

#### 7.3.11.4 Register Map CRC Fault (REG\_MAP\_CRC\_FAULT<sub>n</sub> flag)

The REG\_MAP\_CRC\_FAULT<sub>n</sub> flag indicates if a register map CRC fault occurred due to an unintended register bit flip. Enable the register map CRC using the REG\_MAP\_CRC\_EN bit. However, the register map CRC stops in standby and power-down mode irrespective of the REG\_MAP\_CRC\_EN bit setting. Write 1b to clear the REG\_MAP\_CRC\_FAULT<sub>n</sub> bit to 1b. See the [Register Map CRC](#) section for details about the register map CRC implementation.

#### 7.3.11.5 Internal Memory Fault (MEM\_FAULTn flag)

The MEM\_FAULTn flag indicates if a memory map CRC fault occurred. Similar to the register map CRC, the devices use a memory map CRC to check the internal memory for unintended bit changes. Changes to the internal memory bits can cause undetermined device behavior or degraded device performance. The memory map CRC is always enabled, except in standby and power-down mode, and constantly calculates the CRC value across the internal memory map. The devices compare the calculation result against a memory map CRC value that is stored in the memory map in production. If the internal calculation result and the stored memory map CRC value do not match, the MEM\_FAULTn flag is set to 0b. No other action is taken by the device in the event of a memory map CRC fault. Perform a power cycle or reset the device when the MEM\_FAULTn bit is 0b.

#### 7.3.11.6 Register Write Fault (REG\_WRITE\_FAULTn flag)

The REG\_WRITE\_FAULTn flag indicates if a write access to an invalid register address occurred. This flag sets when an invalid register address is written to, and updates at the next register write command. Reading from an invalid register address does not set the flag.

#### 7.3.11.7 DRDY Indicator (DRDY bit)

The DRDY bit indicates if new data are available for readout. The bit is the inverse of the  $\overline{\text{DRDY}}$  pin. When the transmission of the STATUS header is enabled (STATUS\_EN = 1b), the DRDY bit indicates if the conversion data read within the current I<sup>2</sup>C frame are new or are repeated data from the last read operation.

#### 7.3.11.8 Conversion Counter (CONV\_COUNT[3:0])

The conversion counter (CONV\_COUNT[3:0]) increments every time a new conversion completes. After reaching a counter value of Fh, the counter rolls over to 0h with the completion of the next conversion. Reset the counter to Fh by putting the device into power-down mode or by resetting the device. At the completion of the first conversion after reset or power down, the counter reads 0h.

When the conversion counter is output as part of the STATUS header (STATUS\_EN = 1b), the devices make sure that the conversion counter value always matches to the ADC conversion result that is output in the same I<sup>2</sup>C frame.

## 7.4 Device Functional Modes

### 7.4.1 Power-up and Reset

The ADS1x2C14 is reset in one of three ways:

- Power-on reset (POR)
- Writing to the RESET[5:0] bit field (software reset)
- I<sup>2</sup>C general call reset (software reset)

After a reset occurs, the user registers reset to the respective default settings and the device is in idle mode; no conversions are started. I<sup>2</sup>C communication with the device is possible after the reset process completes. See the [I<sup>2</sup>C Timing Requirements](#) for timing specifications to consider after the various reset events before starting communication with the device.

The RESETn bit indicates if a reset occurred since the last time the RESETn bit was cleared to 1b. Clear the RESETn bit to 1b right after a device reset to get notified of unintended device resets during operation.

#### 7.4.1.1 Power-On Reset (POR)

A power-on reset (POR) circuit holds the device in reset until the DVDD supply exceeds the DVDD POR threshold (TH<sub>DVDD\_POR</sub>). The power-on reset also ensures that the device starts operating in a known good state in case a brown-out event occurred, where the DVDD supply dipped below the DVDD POR threshold. An undervoltage event on AVDD does not cause a device reset, but is indicated by the AVDD\_UVn flag.

#### 7.4.1.2 Reset by Register Write

Initiate a software reset by writing 010110b to the RESET[5:0] bit field. Writing any other value to this bit field does not result in reset.

#### 7.4.1.3 I<sup>2</sup>C General Call Reset

The ADS1x2C14 respond to the I<sup>2</sup>C general-call address (0000 000b) if the R $\overline{W}$  bit is 0b. The device acknowledges the general-call address and, if the next byte is 06h, performs a reset. The general-call software reset has the same effect as writing 010110b to the RESET[5:0] bit field.

## 7.4.2 Operating Modes

The ADS1x2C14 offer four operating modes: power-scalable conversion mode, standby, idle, and power-down mode. Figure 7-13 shows how the device transitions between the different operating modes.

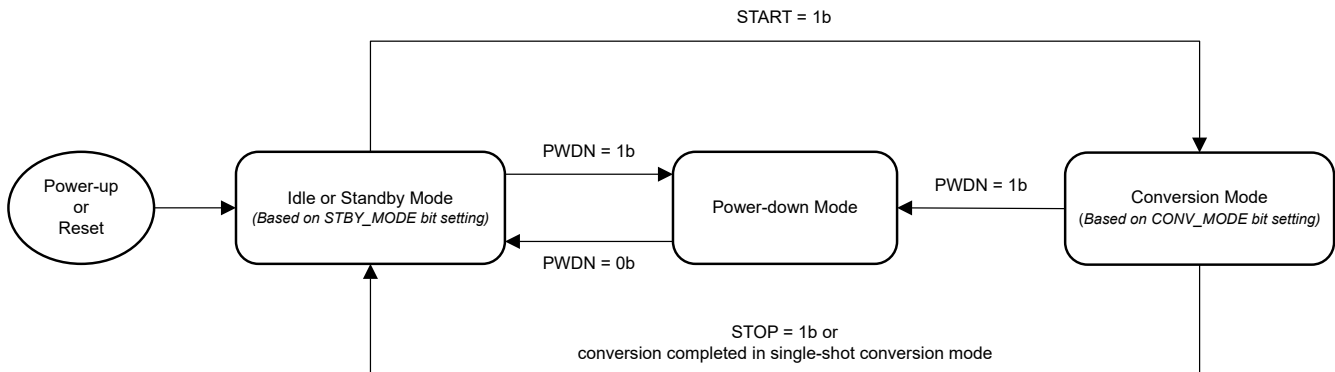

**Figure 7-13. Operating Mode State Diagram**

### 7.4.2.1 Idle and Standby Mode

After reset, the device is in idle mode. All analog circuitry is powered up, based on the respective register bit settings, but no conversions are ongoing, and the digital filter is held in reset.

In standby mode, the ADC, PGA, IDACs, BOCS, reference buffers, reference undervoltage monitor, register map CRC, and memory map CRC power down, irrespective of the register bit settings. The internal voltage reference and oscillator stay powered-up in standby mode.

Setting the START bit to 1b, exits idle or standby mode and starts conversions. When conversions stop, the device transitions to either idle or standby mode depending on the STBY\_MODE bit setting.

Use standby mode to save power when conversions stop. When starting conversions from standby mode, the latency time for the first conversion is longer compared to the latency time when starting conversions from idle mode as explained in the [Digital Filter Latency](#) section.

### 7.4.2.2 Power-Down Mode

In power-down mode, all analog and digital circuitry are powered off, except for circuitry which is required to retain the user register settings. I<sup>2</sup>C communication is still possible. Setting the PWDN bit to 1b powers the device down immediately; any ongoing conversions are aborted. In power-down mode, the conversion counter (CONV\_COUNT[3:0]) resets to Fh, the conversion data clears, and the START bit is ignored.

Any analog inputs configured as GPIO digital outputs transition into a Hi-Z state in power-down mode. To maintain a certain GPIO logic level during power-down, consider external pullup or pulldown resistors on the respective GPIO pins.

Allow the internal voltage reference to start up and settle when coming out of power-down mode before starting any conversions.

### 7.4.2.3 Power-Scalable Conversion Modes

The ADS1x2C14 offer two conversion modes: continuous-conversion and single-shot conversion mode. The CONV\_MODE bit selects the conversion mode.

In addition, the devices offer four speed modes to trade off power consumption, resolution, and data rate. Each speed mode corresponds to a specific modulator clock frequency and device bias current setting. Speed mode 3 ( $f_{MOD} = 1.024\text{MHz}$ ) offers the highest data rates (up to 64kSPS) and the lowest noise at the 20SPS data rate setting. In contrast, speed mode 0 ( $f_{MOD} = 32\text{kHz}$ ) minimizes power consumption at the expense of noise performance. Select the speed mode using the SPEED\_MODE[1:0] bits based on the desired data rate, resolution, and device power consumption requirements.

#### 7.4.2.3.1 Continuous-Conversion Mode

In continuous-conversion mode, the ADC converts indefinitely until stopped by the user. Set the START bit to 1b to start conversions. Setting the START bit to 1b while conversions are ongoing aborts the ongoing conversion and restarts conversions.

Use the STOP bit to stop conversions. The currently ongoing conversion is allowed to finish after the STOP bit is set to 1b. After setting the STOP bit, the STOP bit reads back 1b until conversions are stopped. When conversions stopped, the STOP bit reads back 0b to indicate the device transitioned to idle or standby mode.

Writing 1b to both the START and STOP bits at the same time has no effect.

The last conversion result is still available for readout after conversions stopped. The conversion results only clear after a device reset, in power-down mode, or are overwritten when a new conversion result becomes available.

The START bit takes effect at the rising SCL edge of the ACK bit after the CONVERSION\_CTRL register is written.

If  $\overline{\text{DRDY}}$  is low, setting the START bit drives the  $\overline{\text{DRDY}}$  pin high, however the old conversion data can still be read until the new conversions become available.

When conversions are started or restarted using the START bit, the device hides unsettled conversions and only provides a settled conversion result after the conversion latency period ( $t_{\text{LATENCY}}$ ) plus the optional delay time ( $t_{\text{DELAY}}$ ) as shown in [Digital Filter Settling Time and Conversion Period](#). All subsequent conversions have a conversion period of  $t_{\text{DATA}} = 1 / f_{\text{DATA}} = \text{OSR} / f_{\text{MOD}}$ .

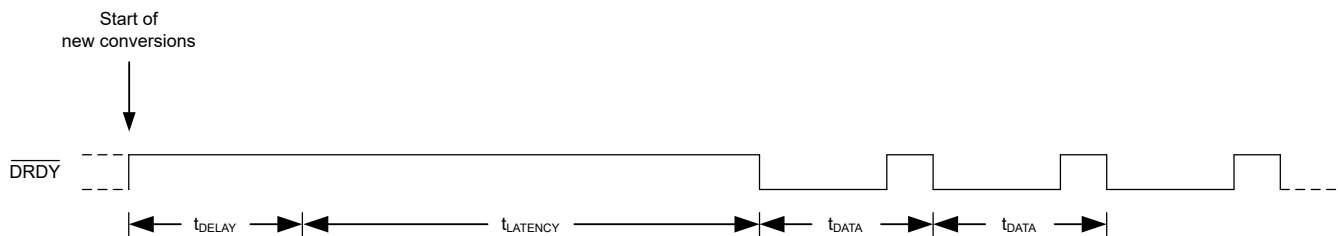

Figure 7-14. Digital Filter Settling Time and Conversion Period

#### 7.4.2.3.2 Single-shot Conversion Mode

In single-shot conversion mode, the ADC performs one single conversion after the START bit is set to 1b. Setting the START bit while a conversion is ongoing aborts the ongoing conversion and restarts a single new conversion. The STOP bit has no effect in single-shot conversion mode.

Equivalent to continuous-conversion mode, the START bit takes effect at the rising SCL edge of the ACK bit after the CONVERSION\_CTRL register is written.

Every conversion in single-shot conversion mode is available after the conversion latency period ( $t_{\text{LATENCY}}$ ) plus the optional delay time. If an input step change occurs during the conversion process, the conversion result is not always fully settled. Another subsequent single-shot conversion is required in that case to output a settled conversion result.

## 7.5 Programming

### 7.5.1 I<sup>2</sup>C Interface

The ADS1x2C14 use an I<sup>2</sup>C-compatible (inter-integrated circuit) interface for serial communication. I<sup>2</sup>C is a 2-wire communication interface that allows communication of a controller device with multiple target devices on the same bus through the use of device addressing. Each target device on an I<sup>2</sup>C bus must have a unique address. Communication on the I<sup>2</sup>C bus always takes place between two devices: one acting as the controller and the other as the target. Both the controller and target can receive and transmit data, but the target can only read or write under the direction of the controller. The ADS1x2C14 always act as I<sup>2</sup>C target devices.

An I<sup>2</sup>C bus consists of two lines: SDA and SCL. SDA carries data and SCL provides the clock. Devices on the I<sup>2</sup>C bus drive the bus lines low by connecting the lines to ground; the devices never drive the bus lines high. Instead, the bus wires are pulled high by pullup resistors; thus, the bus wires are always high when a device is not driving the lines low. As a result of this configuration, two devices do not conflict. If two devices drive the bus simultaneously, there is no driver contention.

See the [I<sup>2</sup>C-Bus Specification and User Manual](#) from NXP Semiconductors™ for more details.

### 7.5.2 I<sup>2</sup>C Address

The ADS1x2C14 have two address pins: A0 and A1. The A0 address pin can be tied to either GND, DVDD, SDA, or SCL, and the A1 address pin can be tied to either GND or DVDD, providing eight unique address options. This pin-configurable address selection allows up to eight different ADS1x2C14 devices to be present on the same I<sup>2</sup>C bus. [Table 7-9](#) shows the truth table for the I<sup>2</sup>C addresses for the possible address pin connections.

At the start of every transaction, that is between the START condition (first falling edge of SDA) and the first falling SCL edge of the address byte, the ADS1x2C14 decode the address configuration again.

**Table 7-9. I<sup>2</sup>C Address Truth Table**

A1	A0	I <sup>2</sup> C ADDRESS
GND	GND	100 0000b
GND	DVDD	100 0001b
GND	SDA	100 0010b
GND	SCL	100 0011b
DVDD	GND	100 0100b
DVDD	DVDD	100 0101b
DVDD	SDA	100 0110b
DVDD	SCL	100 0111b

### 7.5.3 Serial Clock (SCL) and Serial Data (SDA)

The serial clock (SCL) line is used to clock data in and out of the device. The controller always drives the clock line. The ADS1x2C14 cannot act as a controller and as a result can never drive SCL.

The serial data (SDA) line allows for bidirectional communication between the host (the controller) and the ADS1x2C14 (the target). When the controller reads from a ADS1x2C14, the ADS1x2C14 drives the data line; when the controller writes to a ADS1x2C14, the controller drives the data line.

Data on the SDA line must be stable during the high period of the clock. The high or low state of the data line can only change when the SCL line is low. One clock pulse is generated for each data bit transferred. When in an idle state, the controller must hold SCL high.

### 7.5.4 I<sup>2</sup>C Bus Speed

The ADS1x2C14 support I<sup>2</sup>C bus speeds up to 1Mbps. Standard-mode (Sm) with bit rates up to 100kbps, fast-mode (Fm) with bit rates up to 400kbps, and fast-mode plus (Fm+) with bit rates up to 1Mbps are supported. High-speed mode (Hs-mode) is not supported.

### 7.5.5 I<sup>2</sup>C Data Transfer Protocol

Figure 7-15 shows the format of the data transfer. The controller initiates all transactions with the ADS1x2C14 by generating a START (S) condition. A high-to-low transition on the SDA line while SCL is high defines a START condition. The bus is considered to be busy after the START condition.

Following the START condition, the controller sends the 7-bit target address corresponding to the address of the ADS1x2C14 that the controller wants to communicate with. The controller then sends an eighth bit that is a data direction bit ( $R/\overline{W}$ ). A  $R/\overline{W}$  bit of 0b indicates a write operation, and a  $R/\overline{W}$  bit of 1b indicates a read operation. After the  $R/\overline{W}$  bit, the controller generates a ninth SCL pulse and releases the SDA line to allow the ADS1x2C14 to acknowledge (ACK) the reception of the target address by pulling SDA low. In case the device does not recognize the target address, the ADS1x2C14 holds SDA high to indicate a not acknowledge (NACK) signal.

Next follows the data transmission. If the transaction is a read ( $R/\overline{W} = 1b$ ), the ADS1x2C14 outputs data on SDA. If the transaction is a write ( $R/\overline{W} = 0b$ ), the controller outputs data on SDA. Data are transferred byte-wise, most significant bit (MSB) first. The number of bytes that can be transmitted per transfer is unrestricted. Each byte must be acknowledged (via the ACK bit) by the receiver. If the transaction is a read, the controller issues the ACK. If the transaction is a write, the ADS1x2C14 issues the ACK.

The controller terminates all transactions by generating a STOP (P) condition. A low-to-high transition on the SDA line while SCL is high defines a STOP condition. The bus is considered free again  $t_{BUF}$  (bus-free time) after the STOP condition.

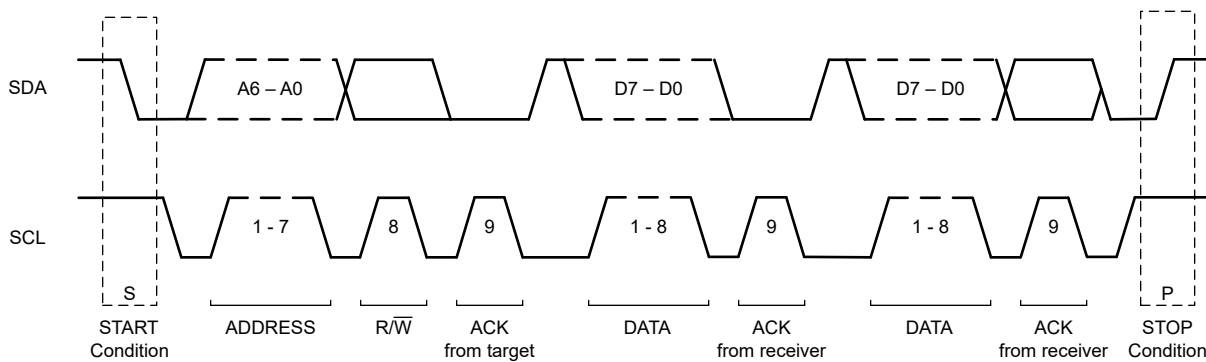

**Figure 7-15. I<sup>2</sup>C Data Transfer Format**

### 7.5.6 I<sup>2</sup>C General Call (Software Reset)

The ADS1x2C14 respond to the I<sup>2</sup>C general-call address (0000 000b) if the  $R/\overline{W}$  bit is 0b. The device acknowledges the general-call address and, if the next byte is 06h, performs a reset. The general-call software reset has the same effect as writing 010110b to the RESET[5:0] bit field.

### 7.5.7 I<sup>2</sup>C Compatibility

The ADS1x2C14 do not perform clock-stretching and include a 50ns glitch filter. Operating the devices on an I<sup>3</sup>C bus is therefore possible.



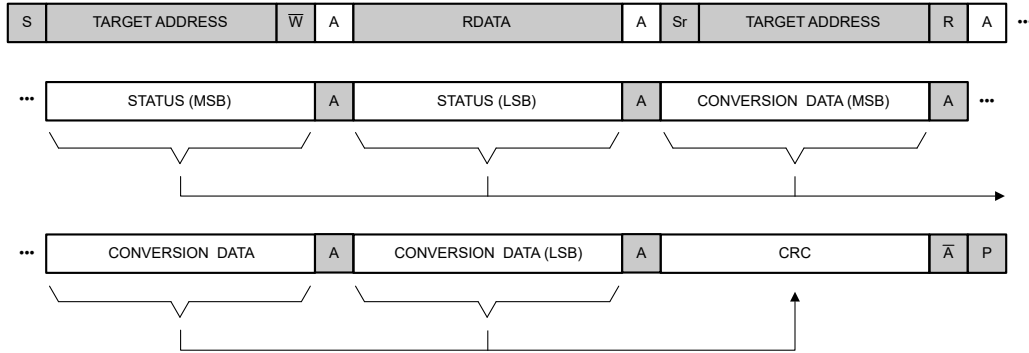

Figure 7-19. Read Conversion Data Sequence (24-Bit Device, STATUS Header and CRC Enabled)

The device outputs a zero-padding byte between the conversion data and CRC byte as shown in Figure 7-20, when the CRC is enabled for the 16-bit device. The zero-padding byte is included in the CRC calculation.

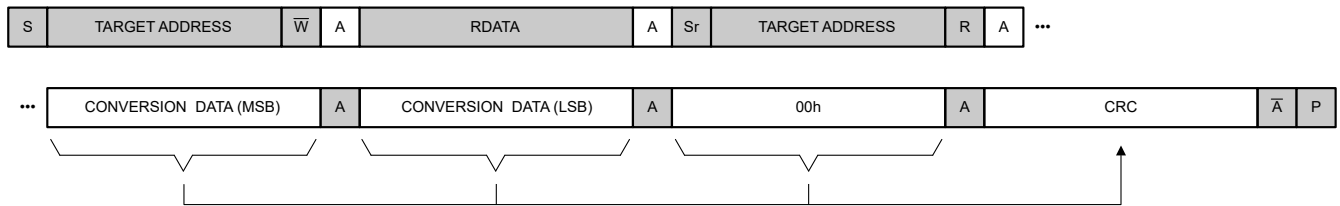

Figure 7-20. Read Conversion Data Sequence (16-Bit Device, STATUS Header Disabled, CRC Enabled)

#### 7.5.8.2 RREG (0100 rrrrb)

The RREG command reads the value of the register at address rrrr. Reading a register must be performed as shown in Figure 7-21 by using two I<sup>2</sup>C communication frames. The first frame is an I<sup>2</sup>C write operation where the R/W bit at the end of the address byte is 0b to indicate a write. In this frame, the controller sends the RREG command including the register address to the ADS1x2C14. The second frame is an I<sup>2</sup>C read operation where the R/W bit at the end of the address byte is 1b to indicate a read. The ADS1x2C14 reports the contents of the requested register in this second I<sup>2</sup>C frame.

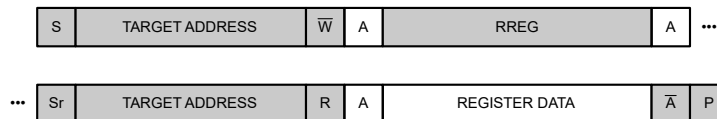

Figure 7-21. Read Register Sequence (CRC Disabled)

Figure 7-22 shows the sequence for reading register data with the CRC enabled (I2C\_CRC\_EN = 1b).

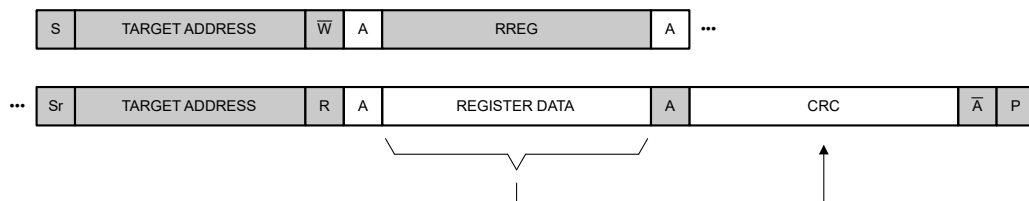

Figure 7-22. Read Register Sequence (CRC Enabled)

### 7.5.8.3 WREG (1000 rrrrb)

The WREG command writes one register byte to the register at address rrrr. Multiple registers can be written within the same I<sup>2</sup>C frame by simply issuing another WREG command without providing a STOP condition following the previous register write. Figure 7-23 shows the sequence for writing an arbitrary number of registers. The R/W bit at the end of the address byte is 0b to indicate a write.

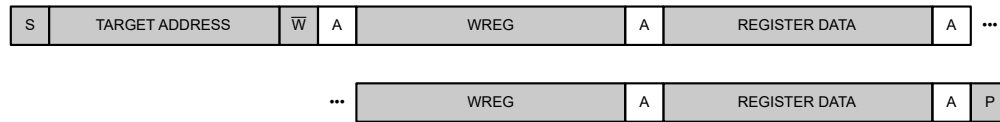

Figure 7-23. Write Register Sequence

### 7.5.9 STATUS Header

The ADS1x2C14 outputs an optional STATUS header as the first two bytes of every conversion data read. Enable the STATUS header transmission using the STATUS\_EN bit. The 16-bit STATUS header is a concatenation of the STATUS\_MSB[7:0] and STATUS\_LSB[7:0] register bits. The fault flags, DRDY bit, GPIO input data, and the conversion counter are all part of these bits. See the Monitors and Status Flags section and the respective register bit descriptions in the Registers section for details.

### 7.5.10 I<sup>2</sup>C CRC

The ADS1x2C14 can output an 8-bit cyclic redundancy check (CRC) code when sending conversion data or register data to the controller to detect transmission errors. Use the I2C\_CRC\_EN bit to enable the I<sup>2</sup>C CRC. The devices append the CRC byte after the conversion data or register data, respectively, as shown in Figure 7-19, Figure 7-20, and Figure 7-22.

The number of bytes used to calculate the CRC code depends on the amount of data bytes transmitted in the frame. Table 7-11 shows the data included in the CRC calculation.

Table 7-11. Data Covered by CRC

ACTION	DEVICE RESOLUTION	STATUS HEADER ENABLED	DATA COVERED BY CRC
Conversion data read	16 bit	No	16 bits of conversion data + 8 bits of zero padding
		Yes	16 bits STATUS header + 16 bits of conversion data + 8 bits of zero padding
	24 bit	No	24 bits of conversion data
		Yes	16 bits STATUS header + 24 bits of conversion data
Register data read	16 or 24 bit	N/A	8 bits of register data

The CRC code calculation is the 8-bit remainder of the bitwise exclusive-OR (XOR) operation of the variable length argument with the CRC polynomial. The CRC is based on the CRC-8-ATM (HEC) polynomial:  $X^8 + X^2 + X^1 + 1$ . The nine coefficients of the polynomial are: 10000111. The CRC calculation is initialized to all 1s to detect errors in the event that SDI and  $\overline{\text{SDO/DRDY}}$  are either stuck high or low.

Figure 7-24 shows a visual representation of the CRC calculation. The following procedure calculates the CRC value:

- Preload the 8-bit shift register, which has XOR blocks located at positions that correspond to the CRC polynomial (07h), with the seed value of FFh.
- Shift in all data bits starting with the most-significant bit (MSB) and re-compute the shift-register value after each bit.
- The resulting shift-register value after all data bits have been shifted in is the computed CRC value.

The example C code available for download [here](#) includes a potential CRC implementation.

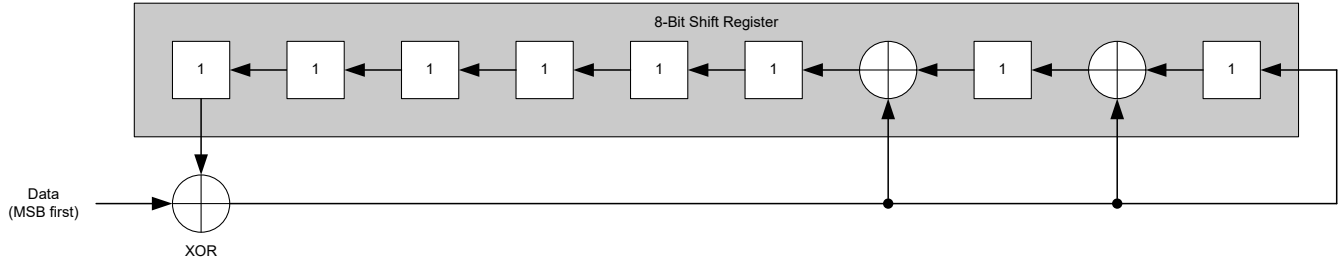

**Figure 7-24. Visual Representation of CRC Calculation**

Register data written to the devices are not CRC protected. To detect transmission errors when writing to the devices, read back the register data after a register has been written.

### 7.5.11 Register Map CRC

The register map CRC detects unintended changes in the register map contents. Register addresses 00h to 04h are excluded from the CRC protection. The CRC calculation is performed across the register address space from 05h to 0Eh. Enable the register map CRC using the REG\_MAP\_CRC\_EN bit. When the register map CRC is enabled, the device constantly calculates an 8-bit CRC value across that register map section and compares the internal calculation result against the CRC value provided by the user in the REG\_MAP\_CRC\_VAL[7:0] bit field. If the internal calculation result and the REG\_MAP\_CRC\_VAL[7:0] do not match, the REG\_MAP\_CRC\_FAULTn flag is set to 0b. No other action is taken by the device in the event of a register map CRC fault.

The CRC calculation begins with the MSB of the register at address 05h and ends with the LSB of the register at address 0Eh using the CRC-8-ATM (HEC) polynomial:  $X^8 + X^2 + X^1 + 1$ . The nine coefficients of the polynomial are: 10000111. See the [I<sup>2</sup>C CRC](#) section for details on the CRC calculation. The CRC calculation is initialized with the seed value of FFh.

The REG\_MAP\_CRC\_FAULTn flag does not indicate unintended bit changes immediately because the CRC calculation is implemented serially. Up to  $t_{p(\text{REG\_MAP\_CRC})} = 640 t_{\text{CLK}}$  cycles can elapse for the REG\_MAP\_CRC\_FAULTn flag to indicate a fault.

Use the following procedure to change register bits without accidentally causing a REG\_MAP\_CRC\_FAULTn indication:

- Disable the register map by setting REG\_MAP\_CRC\_EN = 0b
- Wait the fault response time  $t_{p(\text{REG\_MAP\_CRC})}$
- If the REG\_MAP\_CRC\_FAULTn flag is set to 0b, clear the fault flag by writing 1b to the REG\_MAP\_CRC\_FAULTn bit
- Optional: Verify the REG\_MAP\_CRC\_FAULTn fault flag is cleared to 1b
- Change the device register bits as needed
- Update the REG\_MAP\_CRC\_VAL[7:0] bits based on the new register map settings
- Enable the register map CRC by setting REG\_MAP\_CRC\_EN = 1b

Register bits can also be changed while the register map CRC is enabled, as discussed in the following procedure, but can cause unintended REG\_MAP\_CRC\_FAULTn indications.

- Change the register bits as needed while the register map CRC is enabled
- Update the REG\_MAP\_CRC\_VAL[7:0] bits based on the new register map settings
- Wait the fault response time  $t_{p(\text{REG\_MAP\_CRC})}$
- If the REG\_MAP\_CRC\_FAULTn flag is set to 0b, clear the fault flag by writing 1b to the REG\_MAP\_CRC\_FAULTn bit
- Optional: Verify the REG\_MAP\_CRC\_FAULTn fault flag is cleared to 1b

### 7.5.12 Data Ready ( $\overline{\text{DRDY}}$ ) Pin

GPIO3 can be configured as a dedicated  $\overline{\text{DRDY}}$  output pin (GPIO3\_CFG[1:0] = 10b or 11b, GPIO3\_SRC = 1b).  $\overline{\text{DRDY}}$  drives high when conversions are started, and drives low when conversion data are ready, as shown in Figure 7-27.  $\overline{\text{DRDY}}$  drives back high after the eighth bit of the MSB conversion data is transmitted, as shown in Figure 7-25.

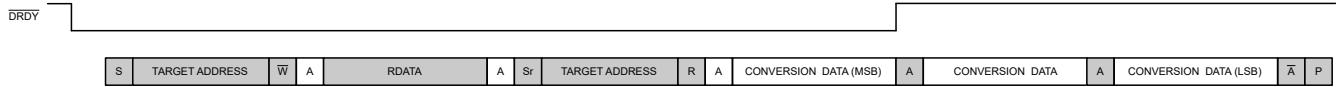

**Figure 7-25.  $\overline{\text{DRDY}}$  Pin Behavior: Reading Latest Available Conversion Data**

If a new conversion completes in the middle of or after the RDATA command byte, the state of the  $\overline{\text{DRDY}}$  pin at the end of the data read operation signals whether the old or the new result is output. If the old result is output,  $\overline{\text{DRDY}}$  stays low, indicating that the new result is not read out, as shown in Figure 7-26. The new conversion result is output when  $\overline{\text{DRDY}}$  is high at the end of the data read operation.

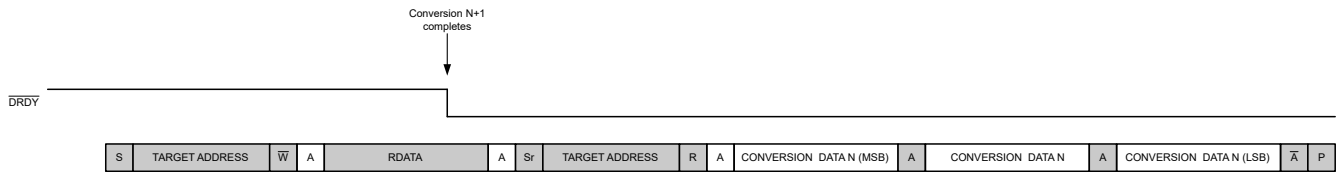

**Figure 7-26.  $\overline{\text{DRDY}}$  Pin Behavior: Reading Old Conversion Data While New Conversion Completes**

If conversion data are not read,  $\overline{\text{DRDY}}$  pulses high  $t_{W(DRH)}$  before the next falling edge, as shown in Figure 7-27.

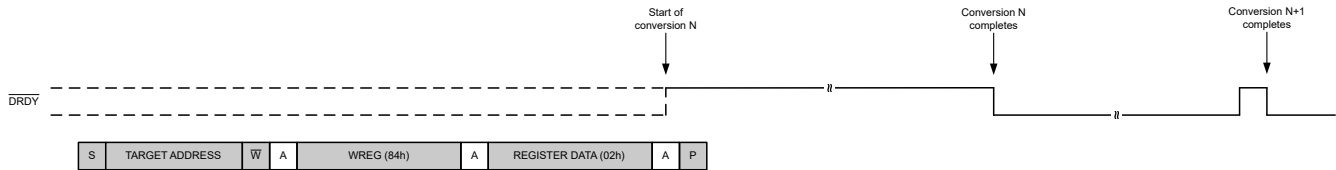

**Figure 7-27.  $\overline{\text{DRDY}}$  Pin Behavior: Missed Reading Intermediate Conversion Result**

Whenever the device is programmed to enter standby mode (STBY\_MODE bit = 1b) after conversions stopped,  $\overline{\text{DRDY}}$  is driven back high  $4 t_{MOD}$  after transitioning low. Figure 7-28 shows an example of the  $\overline{\text{DRDY}}$  pin behavior when entering standby mode using single-shot conversion mode.

Polling the DRDY bit or the state of the  $\overline{\text{DRDY}}$  pin to check for the completion of the conversion is not practical in this particular scenario (STBY\_MODE bit = 1b) because of the short period the  $\overline{\text{DRDY}}$  pin is low. Use one of the other available options to determine when new data are available, such as the  $\overline{\text{DRDY}}$  pin falling edge, reading the conversion counter, or waiting a fixed amount of time equal to or longer than the conversion period.

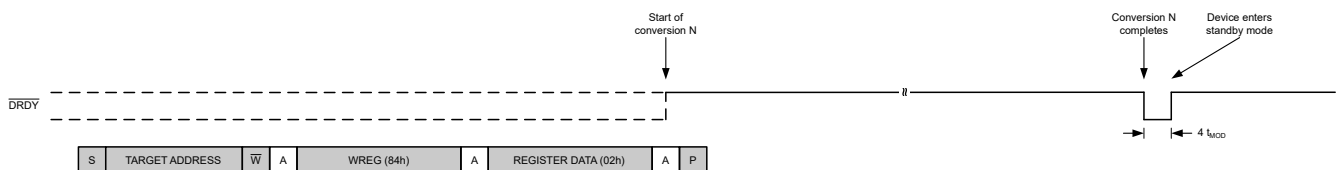

**Figure 7-28.  $\overline{\text{DRDY}}$  Pin Behavior: Entering Standby Mode (Single-Shot Conversion Mode)**

### 7.5.13 Monitoring for New Conversion Data

There are several methods available to determine when new conversion data are ready for retrieval.

1. Monitor the  $\overline{\text{DRDY}}$  pin.
2. Poll the DRDY bit.
3. Evaluate the DRDY bit and conversion counter transmitted as part of the STATUS header.
4. Clock counting using an external clock: Count the number of ADC main clocks to predict when data are ready.

#### 7.5.13.1 $\overline{\text{DRDY}}$ Pin Monitoring

A falling edge on the  $\overline{\text{DRDY}}$  pin indicates that a new conversion completed. Connect the  $\overline{\text{DRDY}}$  pin to a falling edge triggered interrupt-capable GPIO of the host controller. After the host detected the falling  $\overline{\text{DRDY}}$  signal edge, the host reads the conversion data before the next  $\overline{\text{DRDY}}$  falling edge. If an interrupt-capable GPIO is not available, the host can monitor the  $\overline{\text{DRDY}}$  pin level. A logic low level indicates that the latest available conversion result has not been read. A logic high level indicates that no new conversion results are available, and that the latest conversion result has been read previously. Conversion data can be read at any time without concern of data corruption.

#### 7.5.13.2 Reading DRDY Bit and Conversion Counter

Evaluate the DRDY bit to determine when new conversion data are available for readout. Use one of the following two methods to evaluate the DRDY bit:

- The controller periodically reads the STATUS\_MSB register to poll the DRDY bit. If the DRDY bit is set, indicating that a new conversion result is ready for retrieval, the controller subsequently issues an RDATA command to retrieve the data.
- With the STATUS header output enabled, the host periodically issues an RDATA command to receive the STATUS header together with the conversion data within the same I<sup>2</sup>C transaction. If the DRDY bit in that transaction reads 1b, the received conversion data are new. If the DRDY bit is 0b, the host discards the conversion data received in that transaction because the same conversion result has been read previously. In addition, the conversion counter transmitted as part of the STATUS header indicates the count of the conversion that is retrieved within the current I<sup>2</sup>C transaction. The host controller can evaluate the conversion counter to understand if the host read the same conversion result multiple times or if the host missed to read a conversion result.

To avoid missing data, evaluate the DRDY bit at least as often as the output data rate.

#### 7.5.13.3 Clock Counting

Another method to determine when new data are ready is to count ADC main clock cycles, because each conversion requires a deterministic amount of clock cycles. This method is only possible when using an external clock because the internal clock oscillator is not observable. After conversion start, the number of clock cycles required for the first conversion is larger compared to the clock cycles required for all following conversions. The initial number of clock cycles is equal to the latency time of the digital filter as listed in the [Digital Filter Latency](#) section.

### 7.5.14 Conversion Data Format

Conversion data are coded depending on the CODING bit setting. By default, conversion data are coded in binary two's-complement format, MSB first (sign bit). Set the CODING bit to 1b for unipolar straight binary format. Table 7-12 and Table 7-13 show the output code for the 16-bit and 24-bit device, respectively. In binary two's-complement format, the conversion data clips to positive and negative full-scale codes when the input signal exceeds the respective positive and negative full-scale values. In unipolar straight binary format, conversion data clips to the full-scale code when the input signal exceeds the full-scale value, or to the zero code when the input signal value is below zero.

**Table 7-12. Ideal Output Code Versus Input Signal (16-Bit Device)**

DIFFERENTIAL INPUT VOLTAGE (V)	IDEAL OUTPUT CODE <sup>(1)</sup>	
	BINARY TWO'S-COMPLEMENT FORMAT (CODING = 0b)	UNIPOLAR STRAIGHT BINARY FORMAT (CODING = 1b)
$\geq \text{FSR} \times (2^{16} - 1) / 2^{16}$	7FFFh	FFFFh
$\geq \text{FSR} \times (2^{15} - 1) / 2^{15}$		FFFEh
$\text{FSR} / 2^{15}$	0001h	0002h
0	0000h	0000h
$-\text{FSR} / 2^{15}$	FFFFh	
$-\text{FSR} \times (2^{15} - 1) / 2^{15}$	8001h	
$\leq -\text{FSR}$	8000h	

(1) Ideal output data, excluding offset, gain, linearity, and noise errors.

**Table 7-13. Ideal Output Code Versus Input Signal (24-Bit Device)**

DIFFERENTIAL INPUT VOLTAGE (V)	IDEAL OUTPUT CODE <sup>(1)</sup>	
	BINARY TWO'S-COMPLEMENT FORMAT (CODING = 0b)	UNIPOLAR STRAIGHT BINARY FORMAT (CODING = 1b)
$\geq \text{FSR} \times (2^{24} - 1) / 2^{24}$	7FFFFFFh	FFFFFFh
$\geq \text{FSR} \times (2^{23} - 1) / 2^{23}$		FFFFFEh
$\text{FSR} / 2^{23}$	000001h	000002h
0	000000h	000000h
$-\text{FSR} / 2^{23}$	FFFFFFh	
$-\text{FSR} \times (2^{23} - 1) / 2^{23}$	800001h	
$\leq -\text{FSR}$	800000h	

(1) Ideal output data, excluding offset, gain, linearity, and noise errors.

## 8 Registers

Table 8-1 lists the memory-mapped registers for the Registers registers. All register offset addresses not listed in Table 8-1 should be considered as reserved locations and the register contents should not be modified.

**Table 8-1. Register Map**

Address	Acronym	Reset	Bit 7	Bit 6	Bit 5	Bit 4	Bit 3	Bit 2	Bit 1	Bit 0		
ID Registers - not covered by register map CRC												
00h	DEVICE_ID	XXh								DEV_ID[7:0]		
01h	REVISION_ID	XXh								REV_ID[7:0]		
Status Registers - not covered by register map CRC												
02h	STATUS_MSB	3Eh	RESETn	AVDD_UVn	REF_UVn	RESERVED	REG_MAP_CR C_FAULTn	MEM_FAULTn	REG_WRITE_F AULTn	DRDY		
03h	STATUS_LSB	F0h	CONV_COUNT[3:0]				GPIO3_DAT_IN	GPIO2_DAT_IN	GPIO1_DAT_IN	GPIO0_DAT_IN		
Conversion Control Register - not covered by register map CRC												
04h	CONVERSION_CTRL	00h	RESET[5:0]						START	STOP		
Device Configuration Registers - covered by register map CRC												
05h	DEVICE_CFG	00h	PWDN	STBY_MODE	BOCS[1:0]		CLK_SEL	CONV_MODE	SPEED_MODE[1:0]			
06h	DATA_RATE_CFG	00h	DELAY[3:0]				GC_EN	FLTR_OSR[2:0]				
07h	MUX_CFG	01h	AINP[3:0]				AINN[3:0]					
08h	GAIN_CFG	01h	SPARE	SYS_MON[2:0]			GAIN[3:0]					
09h	REFERENCE_CFG	00h	REF_UV_EN	RESERVED	REFP_BUF_EN	REFN_BUF_EN	RESERVED	REF_VAL	REF_SEL[1:0]			
0Ah	DIGITAL_CFG	00h	SPARE	REG_MAP_CR C_EN	I2C_CRC_EN	STATUS_EN	FAULT_PIN_BE HAVIOR	RESERVED	CODING	RESERVED		
0Bh	GPIO_CFG	00h	GPIO3_CFG[1:0]		GPIO2_CFG[1:0]		GPIO1_CFG[1:0]		GPIO0_CFG[1:0]			
0Ch	GPIO_DATA_OUTPUT	00h	GPIO3_SRC	GPIO2_SRC	RESERVED		GPIO3_DAT_O UT	GPIO2_DAT_O UT	GPIO1_DAT_O UT	GPIO0_DAT_O UT		
0Dh	IDAC_MAG_CFG	00h	I2MAG[3:0]				I1MAG[3:0]					
0Eh	IDAC_MUX_CFG	10h	IUNIT	I2MUX[2:0]			RESERVED	I1MUX[2:0]				
Register Map CRC Value Register												
0Fh	REG_MAP_CRC	00h									REG_MAP_CRC_VAL[7:0]	

Complex bit access types are encoded to fit into small table cells. Table 8-2 shows the codes that are used for access types in this section.

**Table 8-2. Registers Access Type Codes**

Access Type	Code	Description
Read Type		
R	R	Read
Write Type		
W	W	Write
Reset or Default Value		
-n		Value after reset or the default value

### 8.1 DEVICE\_ID Register (Address = 00h) [Reset = XXh]

Return to the [Summary Table](#).

**Figure 8-1. DEVICE\_ID Register**

7	6	5	4	3	2	1	0
DEV_ID[7:0]							
R-xxxxxxx							

**Table 8-3. DEVICE\_ID Register Field Descriptions**

Bit	Field	Type	Reset	Description
7:0	DEV_ID[7:0]	R	xxxxxxx	Device ID DEV_ID[7:4] bits are subject to change without notice. DEV_ID[3:0] bits always read 1111b for the 24-bit device and 1110b for the 16-bit device.

## 8.2 REVISION\_ID Register (Address = 01h) [Reset = XXh]

Return to the [Summary Table](#).

**Figure 8-2. REVISION\_ID Register**

7	6	5	4	3	2	1	0
REV_ID[7:0]							
R-xxxxxxx							

**Table 8-4. REVISION\_ID Register Field Descriptions**

Bit	Field	Type	Reset	Description
7:0	REV_ID[7:0]	R	xxxxxxx	Revision ID Values are subject to change without notice.

### 8.3 STATUS\_MSB Register (Address = 02h) [Reset = 3Eh]

Return to the [Summary Table](#).

**Figure 8-3. STATUS\_MSB Register**

7	6	5	4	3	2	1	0
RESETh	AVDD_UVn	REF_UVn	RESERVED	REG_MAP_CRC_FAULTn	MEM_FAULTn	REG_WRITE_FAULTn	DRDY
R/W-0b	R/W-0b	R/W-1b	R-1b	R/W-1b	R-1b	R-1b	R-0b

**Table 8-5. STATUS\_MSB Register Field Descriptions**

Bit	Field	Type	Reset	Description
7	RESETh	R/W	0b	Reset flag Indicates a device reset occurred. Write 1b to clear bit to 1b. 0b = Reset occurred 1b = No reset occurred
6	AVDD_UVn	R/W	0b	AVDD undervoltage fault flag Indicates the AVDD supply voltage dropped below the AVDD undervoltage threshold. AVDD_UVn always sets to 0b when entering power-down mode even when the AVDD supply did not drop below the AVDD undervoltage threshold. Write 1b to clear bit to 1b. 0b = Undervoltage fault occurred 1b = No undervoltage fault occurred
5	REF_UVn	R/W	1b	Reference voltage undervoltage fault flag Indicates the reference voltage selected by the REF_SEL[1:0] bits dropped below the reference undervoltage threshold. Write 1b to clear bit to 1b. Enable the reference undervoltage monitor using the REF_UV_EN bit. 0b = Undervoltage fault occurred 1b = No undervoltage fault occurred
4	RESERVED	R	1b	Reserved Always reads back 1b.
3	REG_MAP_CRC_FAULTn	R/W	1b	Register map CRC fault flag Indicates a register map CRC fault occurred. Write 1b to clear bit to 1b. Enable the register map CRC using the REG_MAP_CRC_EN bit. 0b = Register map CRC fault occurred 1b = No register map CRC fault occurred
2	MEM_FAULTn	R	1b	Memory map CRC fault flag Indicates a memory map CRC fault in the internal memory occurred. Perform a power cycle or reset the device when the bit is 0b. 0b = Memory map CRC fault occurred 1b = No memory map CRC fault occurred
1	REG_WRITE_FAULTn	R	1b	Register access fault flag Indicates a write access to an invalid register address occurred. This flag sets when an invalid register address is written to, and updates at the next register write command. Reading from an invalid register address does not set the flag. 0b = Register access fault occurred 1b = No register access fault occurred
0	DRDY	R	0b	Data-ready indication bit Indicates if new data are available for readout. When the transmission of the STATUS header is enabled (STATUS_EN = 1b), the DRDY bit indicates, if the conversion data read within the current I <sup>2</sup> C frame are new or are repeated data from the last read operation. 0b = Data are not new 1b = Data are new

### 8.4 STATUS\_LSB Register (Address = 03h) [Reset = F0h]

Return to the [Summary Table](#).

**Figure 8-4. STATUS\_LSB Register**

7	6	5	4	3	2	1	0
CONV_COUNT[3:0]			GPIO3_DAT_IN	GPIO2_DAT_IN	GPIO1_DAT_IN	GPIO0_DAT_IN	
R-1111b			R-0b	R-0b	R-0b	R-0b	

**Table 8-6. STATUS\_LSB Register Field Descriptions**

Bit	Field	Type	Reset	Description
7:4	CONV_COUNT[3:0]	R	1111b	Conversion counter The conversion counter increments every time a new conversion completes. After reaching a counter value of Fh, the counter rolls over to 0h with the completion of the next conversion. The counter only resets to Fh (and the conversion data clear) in power-down mode or after a device reset. At the completion of the first conversion after reset or power down, the counter reads 0h.
3	GPIO3_DAT_IN	R	0b	GPIO3 data Read back value of GPIO3 when AIN7/GPIO3/DRDY/CLK is configured as digital input, digital output, or DRDY output. Bit reads 0b when the GPIO function is disabled (GPIO3_CFG[1:0] = 00b) or the clock input function is selected (GPIO3_CFG[1:0] = 01b, CLK_SEL = 1b). 0b = Low 1b = High
2	GPIO2_DAT_IN	R	0b	GPIO2 data Read back value of GPIO2 when AIN6/GPIO2/FAULT is configured as digital input, digital output, or static FAULT output. Bit reads 0b when the GPIO function is disabled (GPIO2_CFG[1:0] = 00b) or when GPIO2 is configured as FAULT output with heart beat function (GPIO2_CFG[1:0] = 10b or 11b, GPIO2_SRC = 1b, FAULT_PIN_BEHAVIOR = 1b). 0b = Low 1b = High
1	GPIO1_DAT_IN	R	0b	GPIO1 data Read back value of GPIO1 when AIN5/REFN/GPIO1 is configured as digital input or output. Bit reads 0b when the GPIO function is disabled (GPIO1_CFG[1:0] = 00b). 0b = Low 1b = High
0	GPIO0_DAT_IN	R	0b	GPIO0 data Read back value of GPIO0 when AIN4/REFP/GPIO0 is configured as digital input or output. Bit reads 0b when the GPIO function is disabled (GPIO0_CFG[1:0] = 00b). 0b = Low 1b = High

### 8.5 CONVERSION\_CTRL Register (Address = 04h) [Reset = 00h]

Return to the [Summary Table](#).

**Figure 8-5. CONVERSION\_CTRL Register**

7	6	5	4	3	2	1	0
RESET[5:0]						START	STOP
R/W-000000b						R/W-0b	R/W-0b

**Table 8-7. CONVERSION\_CTRL Register Field Descriptions**

Bit	Field	Type	Reset	Description
7:2	RESET[5:0]	R/W	000000b	Reset device Write 010110b to reset the ADC. The START and STOP bits must be set to 0b in the same write operation to reset the ADC. These bits always read 000000b.
1	START	R/W	0b	Start conversion Write 1b to start or restart conversions. In single-shot conversion mode, one conversion is started. In continuous conversion mode, conversions are started and continue until stopped by the STOP bit. Writing 1b while a conversion is ongoing restarts the conversion. Writing 1b to both the START and STOP bits at the same time has no effect. The START bit is self-clearing and always reads 0b. 0b = No operation 1b = Start or restart conversion
0	STOP	R/W	0b	Stop conversion Write 1b to stop conversions in continuous-conversion mode. Ongoing conversions are allowed to complete. The STOP bit has no effect in single-shot conversion mode. Writing 1b to both the START and STOP bits at the same time has no effect. The STOP bit clears to 0b after the ongoing conversion finishes or when the START bit is set before the ongoing conversion finishes, which aborts the ongoing conversion and restarts a new conversion. 0b = No operation 1b = Stop conversion after the current conversion completes

## 8.6 DEVICE\_CFG Register (Address = 05h) [Reset = 00h]

Return to the [Summary Table](#).

**Figure 8-6. DEVICE\_CFG Register**

7	6	5	4	3	2	1	0
PWDN	STBY_MODE	BOCS[1:0]		CLK_SEL	CONV_MODE	SPEED_MODE[1:0]	
R/W-0b	R/W-0b	R/W-00b		R/W-0b	R/W-0b	R/W-00b	

**Table 8-8. DEVICE\_CFG Register Field Descriptions**

Bit	Field	Type	Reset	Description
7	PWDN	R/W	0b	Power-down mode selection Powers down all circuitry except for circuitry necessary to retain the user register settings. I <sup>2</sup> C communication is still possible. In power-down mode, the conversion counter (CONV_COUNT[3:0]) resets to Fh, the conversion data clears, and the START bit is ignored. Setting the PWDN bit to 1b powers the device down immediately; any ongoing conversions are aborted. Any analog inputs configured as GPIO digital outputs transition into a Hi-Z state in power-down mode. To maintain a certain logic level during power down, consider external pullup or pulldown resistors on the respective GPIO pins. 0b = Active mode 1b = Power-down mode
6	STBY_MODE	R/W	0b	Standby mode selection This bit enables the auto engagement of the low-power standby mode after conversions are stopped. 0b = Idle mode; device remains fully powered when conversions stop. 1b = Standby mode; when conversions stop, the ADC, PGA, IDACs, BOCS, REF buffers and REF UV monitor power down and the heart beat output signal of the FAULTn pin, if enabled, stops. The FAULTn pin behaves as if configured for static output in standby mode. The internal VREF and AVDD UV monitor stay powered up. The register map CRC and memory map CRC are disabled in standby mode. Standby mode is exited when conversions restart.
5:4	BOCS[1:0]	R/W	00b	Burnout current source and sink selection Enables and selects the value of the burnout current source and sink. Disable the burnout current sources when using global chop mode (GC_EN = 1b). 00b = Disabled 01b = 0.2μA 10b = 1μA 11b = 10μA
3	CLK_SEL	R/W	0b	Clock source selection Selects the clock source for the device. To change from internal oscillator to external clock, first set GPIO3_CFG = 01b to configure the GPIO3 pin as external clock input, then set CLK_SEL = 1b. 0b = Internal oscillator 1b = External clock
2	CONV_MODE	R/W	0b	Conversion mode selection Selects the conversion mode for the device. 0b = Continuous-conversion mode 1b = Single-shot conversion mode
1:0	SPEED_MODE[1:0]	R/W	00b	Speed mode selection Selects the speed mode for the device. 00b = Speed mode 0 (f <sub>MOD</sub> = 32kHz) 01b = Speed mode 1 (f <sub>MOD</sub> = 256kHz) 10b = Speed mode 2 (f <sub>MOD</sub> = 512kHz) 11b = Speed mode 3 (f <sub>MOD</sub> = 1024kHz)

### 8.7 DATA\_RATE\_CFG Register (Address = 06h) [Reset = 00h]

Return to the [Summary Table](#).

**Figure 8-7. DATA\_RATE\_CFG Register**

7	6	5	4	3	2	1	0
DELAY[3:0]				GC_EN	FLTR_OSR[2:0]		
R/W-0000b				R/W-0b	R/W-000b		

**Table 8-9. DATA\_RATE\_CFG Register Field Descriptions**

Bit	Field	Type	Reset	Description
7:4	DELAY[3:0]	R/W	0000b	<p>Programmable conversion start delay selection Sets the programmable conversion start delay time for the first conversion after a digital filter reset. This delay time is also used as the delay between conversions when global-chop mode is enabled.</p> <p>0000b = 0x <math>t_{MOD}</math>                      0001b = 1x <math>t_{MOD}</math>                      0010b = 2x <math>t_{MOD}</math>                      0011b = 4x <math>t_{MOD}</math>                      0100b = 8x <math>t_{MOD}</math>                      0101b = 16x <math>t_{MOD}</math>                      0110b = 32x <math>t_{MOD}</math>                      0111b = 64x <math>t_{MOD}</math>                      1000b = 128x <math>t_{MOD}</math>                      1001b = 256x <math>t_{MOD}</math>                      1010b = 512x <math>t_{MOD}</math>                      1011b = 1024x <math>t_{MOD}</math>                      1100b = 2048x <math>t_{MOD}</math>                      1101b = 4096x <math>t_{MOD}</math>                      1110b = 8192x <math>t_{MOD}</math>                      1111b = 16384x <math>t_{MOD}</math></p>
3	GC_EN	R/W	0b	<p>Global-chop mode enable Enables global-chop mode. When enabled, the device automatically swaps the analog inputs and takes the average of two consecutive conversions to cancel the internal offset voltage.</p> <p>0b = Disabled                      1b = Enabled</p>
2:0	FLTR_OSR[2:0]	R/W	000b	<p>Filter OSR selection Selects the OSR of the digital filter or the output data rate. For settings where an OSR is stated, the output data rate calculates to <math>f_{DATA} = f_{MOD} / OSR</math>. For the 20SPS and 25SPS data rate settings, the digital filter adjusts the OSR automatically based on the selected speed mode. The 20SPS and 25SPS data rates are valid for a nominal clock frequency of <math>f_{CLK} = 4.096\text{MHz}</math>. The data rates scale proportional with the clock frequency. At output data rates of 20SPS and 25SPS the digital filter provides 50Hz and 60Hz line-cycle rejection.</p> <p>000b = OSR = 16 (Sinc4 OSR = 16)                      001b = OSR = 32 (Sinc4 OSR = 32)                      010b = OSR = 128 (Sinc4 OSR = 32, Sinc1 OSR = 4)                      011b = OSR = 256 (Sinc4 OSR = 32, Sinc1 OSR = 8)                      100b = OSR = 512 (Sinc4 OSR = 32, Sinc1 OSR = 16)                      101b = OSR = 1024 (Sinc4 OSR = 32, Sinc1 OSR = 32)                      110b = <math>f_{DATA} = 25\text{SPS}</math> (independent of speed mode)                      111b = <math>f_{DATA} = 20\text{SPS}</math> (independent of speed mode)</p>

### 8.8 MUX\_CFG Register (Address = 07h) [Reset = 01h]

Return to the [Summary Table](#).

**Figure 8-8. MUX\_CFG Register**

7	6	5	4	3	2	1	0
AINP[3:0]				AINN[3:0]			
R/W-0000b				R/W-0001b			

**Table 8-10. MUX\_CFG Register Field Descriptions**

Bit	Field	Type	Reset	Description
7:4	AINP[3:0]	R/W	0000b	<p>Positive multiplexer input selection Selects the positive analog input for the ADC. Analog inputs AIN4 and AIN5 can still be used as analog inputs, even when the inputs are configured as REFP and REFN inputs, respectively. When an analog input is configured as GPIO, the analog input can still be selected by the Mux and used to measure back the voltage on the GPIO pin.</p> <p>0000b = AIN0 0001b = AIN1 0010b = AIN2 0011b = AIN3 0100b = AIN4 0101b = AIN5 0110b = AIN6 0111b = AIN7 1000b = GND 1001b = GND 1010b = GND 1011b = GND 1100b = GND 1101b = GND 1110b = GND 1111b = GND</p>
3:0	AINN[3:0]	R/W	0001b	<p>Negative multiplexer input selection Selects the negative analog input for the ADC. Analog inputs AIN4 and AIN5 can still be used as analog inputs, even when the inputs are configured as REFP and REFN inputs, respectively. When an analog input is configured as GPIO, the analog input can still be selected by the Mux and used to measure back the voltage on the GPIO pin.</p> <p>0000b = AIN0 0001b = AIN1 0010b = AIN2 0011b = AIN3 0100b = AIN4 0101b = AIN5 0110b = AIN6 0111b = AIN7 1000b = GND 1001b = GND 1010b = GND 1011b = GND 1100b = GND 1101b = GND 1110b = GND 1111b = GND</p>

### 8.9 GAIN\_CFG Register (Address = 08h) [Reset = 01h]

Return to the [Summary Table](#).

Figure 8-9. GAIN\_CFG Register

7	6	5	4	3	2	1	0
SPARE	SYS_MON[2:0]			GAIN[3:0]			
R/W-0b	R/W-000b			R/W-0001b			

Table 8-11. GAIN\_CFG Register Field Descriptions

Bit	Field	Type	Reset	Description
7	SPARE	R/W	0b	Spare bit Bit setting has no effect. Provided as R/W bit as a means to check the register map CRC.
6:4	SYS_MON[2:0]	R/W	000b	System monitor selection Selects one of the system monitors as the inputs for the PGA. The AINP[3:0] and AINN[3:0] bits have no effect when one of the system monitors is selected. The analog inputs are disconnected from the PGA when a system monitor is selected. The internal reference with the value set in the REF_VAL bit is automatically selected for settings 010b to 101b. Select an appropriate PGA gain setting for the respective measurement. 000b = Disabled 001b = Internal short of differential PGA inputs to (AVDD / 2) 010b = Internal temperature sensor 011b = External ( $V_{REFP} - V_{REFN}$ ) / 8 100b = AVDD / 8 101b = DVDD / 8 110b = Do not use 111b = Do not use
3:0	GAIN[3:0]	R/W	0001b	PGA gain selection Selects the gain of the PGA. 0000b = 0.5 0001b = 1 0010b = 2 0011b = 4 0100b = 5 0101b = 8 0110b = 10 0111b = 16 1000b = 20 1001b = 32 1010b = 50 1011b = 64 1100b = 100 1101b = 128 1110b = 200 1111b = 256

## 8.10 REFERENCE\_CFG Register (Address = 09h) [Reset = 00h]

Return to the [Summary Table](#).

**Figure 8-10. REFERENCE\_CFG Register**

7	6	5	4	3	2	1	0
REF_UV_EN	RESERVED	REFP_BUF_EN	REFN_BUF_EN	RESERVED	REF_VAL	REF_SEL[1:0]	
R/W-0b	R-0b	R/W-0b	R/W-0b	R-0b	R/W-0b	R/W-00b	

**Table 8-12. REFERENCE\_CFG Register Field Descriptions**

Bit	Field	Type	Reset	Description
7	REF_UV_EN	R/W	0b	Reference voltage monitor enable Enables the voltage reference monitor to detect when the selected voltage reference, as selected by the REF_SEL[1:0] bits, drops below the reference undervoltage threshold. 0b = Disabled 1b = Enabled
6	RESERVED	R	0b	Reserved Always reads back 0b.
5	REFP_BUF_EN	R/W	0b	Positive reference buffer enable Enables the positive reference buffer. Disable the positive reference buffer when the internal reference or the analog supply is selected as the reference source using the REF_SEL[1:0] bit field. 0b = Disabled 1b = Enabled
4	REFN_BUF_EN	R/W	0b	Negative reference buffer enable Enables the negative reference buffer. Disable the negative reference buffer when the internal reference or the analog supply is selected as the reference source using the REF_SEL[1:0] bit field. 0b = Disabled 1b = Enabled
3	RESERVED	R	0b	Reserved Always reads back 0b.
2	REF_VAL	R/W	0b	Internal reference voltage value selection Selects the voltage of the internal reference. The internal voltage reference is always enabled. 0b = 1.25V 1b = 2.5V
1:0	REF_SEL[1:0]	R/W	00b	Reference voltage selection Selects the reference voltage for the ADC. Set GPIO0_CFG[1:0] = 00b and GPIO1_CFG[1:0] = 00b when the external voltage reference is selected. 00b = Internal voltage reference 01b = External voltage reference 10b = AVDD 11b = AVDD

### 8.11 DIGITAL\_CFG Register (Address = 0Ah) [Reset = 00h]

Return to the [Summary Table](#).

**Figure 8-11. DIGITAL\_CFG Register**

7	6	5	4	3	2	1	0
SPARE	REG_MAP_CRC_EN	I2C_CRC_EN	STATUS_EN	FAULT_PIN_BEHAVI OR	RESERVED	CODING	RESERVED
R/W-0b	R/W-0b	R/W-0b	R/W-0b	R/W-0b	R-0b	R/W-0b	R-0b

**Table 8-13. DIGITAL\_CFG Register Field Descriptions**

Bit	Field	Type	Reset	Description
7	SPARE	R/W	0b	Spare bit Bit setting has no effect. Provided as R/W bit as a means to check the register map CRC.
6	REG_MAP_CRC_EN	R/W	0b	Register map CRC enable Enables the register map CRC for register addresses 05h to 0Eh. 0b = Disabled 1b = Enabled
5	I2C_CRC_EN	R/W	0b	I <sup>2</sup> C CRC enable Enables the I <sup>2</sup> C output CRC for register and conversion data reads. 0b = Disabled 1b = Enabled
4	STATUS_EN	R/W	0b	STATUS header output enable Enables the STATUS header (STATUS_MSB + STATUS_LSB registers) transmission as the first two bytes of every conversion data read. 0b = Disabled 1b = Enabled
3	FAULT_PIN_BEHAVIOR	R/W	0b	FAULT pin behavior selection Selects the behavior of the FAULT pin, when GPIO2 is configured as FAULT output (GPIO2_CFG = 10b or 11b, GPIO2_SRC = 1b). 0b = Static. Output is low when a fault occurred, otherwise output is high. 1b = Heart beat. Output is low when a fault occurred, otherwise output is a 50% duty-cycle signal with a frequency of $f_{MOD} / 256$ .
2	RESERVED	R	0b	Reserved Always reads back 0b.
1	CODING	R/W	0b	Conversion data coding selection Selects the coding of the conversion data. 0b = Binary two's complement 1b = Unipolar straight binary
0	RESERVED	R	0b	Reserved Always reads back 0b.

## 8.12 GPIO\_CFG Register (Address = 0Bh) [Reset = 00h]

Return to the [Summary Table](#).

**Figure 8-12. GPIO\_CFG Register**

7	6	5	4	3	2	1	0
GPIO3_CFG[1:0]		GPIO2_CFG[1:0]		GPIO1_CFG[1:0]		GPIO0_CFG[1:0]	
R/W-00b		R/W-00b		R/W-00b		R/W-00b	

**Table 8-14. GPIO\_CFG Register Field Descriptions**

Bit	Field	Type	Reset	Description
7:6	GPIO3_CFG[1:0]	R/W	00b	GPIO3 configuration Configures the GPIO3 pin behavior. 00b = Disabled (High-Z) 01b = Digital input (CLK_SEL = 0b) or external clock input (CLK_SEL = 1b) 10b = Push-pull digital output (with readback) 11b = Open-drain digital output (with readback)
5:4	GPIO2_CFG[1:0]	R/W	00b	GPIO2 configuration Configures the GPIO2 pin behavior. 00b = Disabled (High-Z) 01b = Digital input 10b = Push-pull digital output (with readback) 11b = Open-drain digital output (with readback)
3:2	GPIO1_CFG[1:0]	R/W	00b	GPIO1 configuration Configures the GPIO1 pin behavior. 00b = Disabled (High-Z) 01b = Digital input 10b = Push-pull digital output (with readback) 11b = Open-drain digital output (with readback)
1:0	GPIO0_CFG[1:0]	R/W	00b	GPIO0 configuration Configures the GPIO0 pin behavior. 00b = Disabled (High-Z) 01b = Digital input 10b = Push-pull digital output (with readback) 11b = Open-drain digital output (with readback)

### 8.13 GPIO\_DATA\_OUTPUT Register (Address = 0Ch) [Reset = 00h]

Return to the [Summary Table](#).

**Figure 8-13. GPIO\_DATA\_OUTPUT Register**

7	6	5	4	3	2	1	0
GPIO3_SRC	GPIO2_SRC	RESERVED		GPIO3_DAT_OUT	GPIO2_DAT_OUT	GPIO1_DAT_OUT	GPIO0_DAT_OUT
R/W-0b	R/W-0b	R-00b		R/W-0b	R/W-0b	R/W-0b	R/W-0b

**Table 8-15. GPIO\_DATA\_OUTPUT Register Field Descriptions**

Bit	Field	Type	Reset	Description
7	GPIO3_SRC	R/W	0b	GPIO3 data source selection Selects the data source of the GPIO3 pin when GPIO3 is configured as digital output. 0b = GPIO3_DAT_OUT bit 1b = DRDY
6	GPIO2_SRC	R/W	0b	GPIO2 data source selection Selects the data source of the GPIO2 pin when GPIO2 is configured as digital output. The FAULT pin is low when any of the AVDD_UVn, REF_UVn, REG_MAP_CRC_FAULTn, or MEM_FAULTn status bits are 0b. 0b = GPIO2_DAT_OUT bit 1b = FAULT
5:4	RESERVED	R	00b	Reserved Always reads back 00b.
3	GPIO3_DAT_OUT	R/W	0b	GPIO3 data Write value of GPIO3 when configured as digital output. Bit setting has no effect when GPIO3 is configured as digital input or as digital output with DRDY as the data source. 0b = Low 1b = High
2	GPIO2_DAT_OUT	R/W	0b	GPIO2 data Write value of GPIO2 when configured as digital output. Bit setting has no effect when GPIO2 is configured as digital input or as digital output with FAULT as the data source. 0b = Low 1b = High
1	GPIO1_DAT_OUT	R/W	0b	GPIO1 data Write value of GPIO1 when configured as digital output. Bit setting has no effect when GPIO1 is configured as digital input. 0b = Low 1b = High
0	GPIO0_DAT_OUT	R/W	0b	GPIO0 data Write value of GPIO0 when configured as digital output. Bit setting has no effect when GPIO0 is configured as digital input. 0b = Low 1b = High

### 8.14 IDAC\_MAG\_CFG Register (Address = 0Dh) [Reset = 00h]

Return to the [Summary Table](#).

**Figure 8-14. IDAC\_MAG\_CFG Register**

7	6	5	4	3	2	1	0
I2MAG[3:0]				I1MAG[3:0]			
R/W-0000b				R/W-0000b			

**Table 8-16. IDAC\_MAG\_CFG Register Field Descriptions**

Bit	Field	Type	Reset	Description
7:4	I2MAG[3:0]	R/W	0000b	IDAC2 magnitude selection Selects the value of the excitation current source, IDAC2. 0000b = Disabled 0001b = 1x IUNIT 0010b = 10x IUNIT 0011b = 20x IUNIT 0100b = 30x IUNIT 0101b = 40x IUNIT 0110b = 50x IUNIT 0111b = 60x IUNIT 1000b = 70x IUNIT 1001b = 80x IUNIT 1010b = 90x IUNIT 1011b = 100x IUNIT 1100b = 100x IUNIT 1101b = 100x IUNIT 1110b = 100x IUNIT 1111b = 100x IUNIT
3:0	I1MAG[3:0]	R/W	0000b	IDAC1 magnitude selection Selects the value of the excitation current source, IDAC1. 0000b = Disabled 0001b = 1x IUNIT 0010b = 10x IUNIT 0011b = 20x IUNIT 0100b = 30x IUNIT 0101b = 40x IUNIT 0110b = 50x IUNIT 0111b = 60x IUNIT 1000b = 70x IUNIT 1001b = 80x IUNIT 1010b = 90x IUNIT 1011b = 100x IUNIT 1100b = 100x IUNIT 1101b = 100x IUNIT 1110b = 100x IUNIT 1111b = 100x IUNIT

### 8.15 IDAC\_MUX\_CFG Register (Address = 0Eh) [Reset = 10h]

Return to the [Summary Table](#).

**Figure 8-15. IDAC\_MUX\_CFG Register**

7	6	5	4	3	2	1	0
IUNIT	I2MUX[2:0]			RESERVED	I1MUX[2:0]		
R/W-0b	R/W-001b			R-0b	R/W-000b		

**Table 8-17. IDAC\_MUX\_CFG Register Field Descriptions**

Bit	Field	Type	Reset	Description
7	IUNIT	R/W	0b	IDAC unit current selection Selects the unit current for the excitation current sources, IDAC1 and IDAC2. 0b = 1µA 1b = 10µA
6:4	I2MUX[2:0]	R/W	001b	IDAC2 output pin selection Selects the output pin for IDAC2. IDAC1 and IDAC2 can be routed to the same pin if needed. An analog input that is used as an IDAC2 output, can still be used as an analog or reference input. 000b = AIN0 001b = AIN1 010b = AIN2 011b = AIN3 100b = AIN4 101b = AIN5 110b = AIN6 111b = AIN7
3	RESERVED	R	0b	Reserved Always reads back 0b.
2:0	I1MUX[2:0]	R/W	000b	IDAC1 output pin selection Selects the output pin for IDAC1. IDAC1 and IDAC2 can be routed to the same pin if needed. An analog input that is used as an IDAC1 output, can still be used as an analog or reference input. 000b = AIN0 001b = AIN1 010b = AIN2 011b = AIN3 100b = AIN4 101b = AIN5 110b = AIN6 111b = AIN7

**8.16 REG\_MAP\_CRC Register (Address = 0Fh) [Reset = 00h]**

Return to the [Summary Table](#).

**Figure 8-16. REG\_MAP\_CRC Register**

7	6	5	4	3	2	1	0
REG_MAP_CRC_VAL[7:0]							
R/W-00000000b							

**Table 8-18. REG\_MAP\_CRC Register Field Descriptions**

Bit	Field	Type	Reset	Description
7:0	REG_MAP_CRC_VAL[7:0]	R/W	00000000 b	Register map CRC value The register map CRC value is the user-computed CRC value of registers 05h to 0Eh. The CRC value written to this register is compared to an internal CRC calculation. If the values do not match, the REG_MAP_CRC_FAULTn bit in the STATUS_MSB register is set. Enable the register map CRC using the REG_MAP_CRC_EN bit.

## 9 Application and Implementation

### Note

Information in the following applications sections is not part of the TI component specification, and TI does not warrant its accuracy or completeness. TI's customers are responsible for determining suitability of components for their purposes, as well as validating and testing their design implementation to confirm system functionality.

### 9.1 Application Information

#### 9.1.1 Serial Interface Connections

Figure 9-1 shows the basic interface connections for the ADS1x2C14.

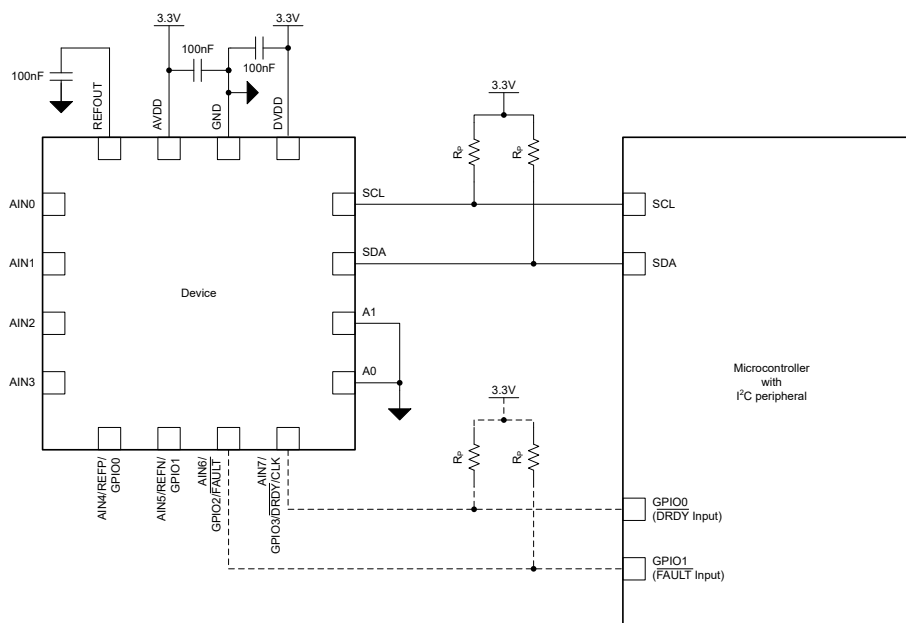

**Figure 9-1. Serial Interface Connections**

The ADS1x2C14 interface directly to I<sup>2</sup>C controllers with standard-mode, fast-mode, or fast-mode plus bus speeds. The devices can be used on an I<sup>3</sup>C bus because the devices do not perform clock-stretching and include a 50ns glitch filter.

Pullup resistors are required on both the SDA and SCL lines. The size of these resistors depends on the bus speed and capacitance of the bus lines. Higher-value resistors yield lower power consumption when the bus lines are pulled low, but increase the transition times on the bus, which limits the bus speed. Lower-value resistors allow higher interface speeds, but at the expense of higher power consumption when the bus lines are pulled low. Long bus lines have higher capacitance and require smaller pullup resistors to compensate. See the [I<sup>2</sup>C-Bus Specification and User Manual](#) for details on pullup resistor sizing.

Optionally, route the dedicated  $\overline{\text{DRDY}}$  pin to a falling edge triggered interrupt-capable GPIO of the host controller in case new data ready indication through an interrupt is desired. For that purpose, configure the AIN7/GPIO3/ $\overline{\text{DRDY}}$ /CLK pin as a  $\overline{\text{DRDY}}$  output (GPIO3\_CFG = 10b or 11b and GPIO3\_SRC = 1b).

The  $\overline{\text{FAULT}}$  pin can be interfaced to the host controller as well in case fault indication through a pin is desired besides the fault indication through the fault flags. For that purpose, configure the AIN6/GPIO2/ $\overline{\text{FAULT}}$  pin as a  $\overline{\text{FAULT}}$  output (GPIO2\_CFG = 10b or 11b and GPIO2\_SRC = 1b).

Add pullup resistors at the  $\overline{\text{DRDY}}$  or  $\overline{\text{FAULT}}$  pins in case the pins are configured as open-drain outputs.

### 9.1.2 Connecting Multiple Devices on the Same I<sup>2</sup>C Bus

Up to eight ADS1x2C14 devices can be operated on a single I<sup>2</sup>C bus by using different address pin configurations for each device. Use the address pins, A0 and A1, to set the ADS1x2C14 to one of eight different I<sup>2</sup>C addresses as specified in the [I<sup>2</sup>C Address](#) section.

Figure 9-2 shows an example with three ADS1x2C14 devices on the same I<sup>2</sup>C bus. One set of pullup resistors is required per bus line. If needed, decrease the pullup resistor values to compensate for the additional bus capacitance presented by multiple devices and increased line length.

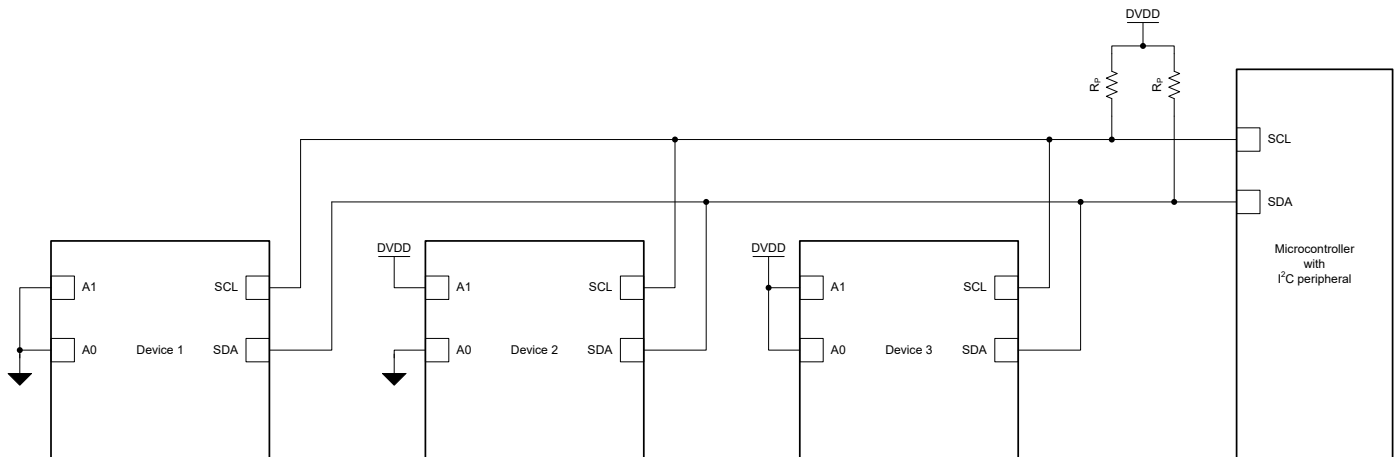

**Figure 9-2. Connecting Multiple ADS1x2C14 Devices on the Same I<sup>2</sup>C Bus**

### 9.1.3 Unused Inputs and Outputs

Follow these guidelines for unused device pin connections:

- Leave any unused analog inputs floating or connect the unused analog inputs to GND.
- When not using the REFP, REFN, GPIO0, GPIO1, GPIO2, GPIO3,  $\overline{\text{FAULT}}$ ,  $\overline{\text{DRDY}}$ , or CLK functions, configure the respective pins as analog inputs (GPIOx\_CFG[1:0] = 00b) and follow the guidelines for unused analog inputs above.

### 9.1.4 Device Initialization

Figure 9-3 illustrates the sequence steps required to initialize the ADS1x2C14, and to start conversions in continuous-conversion mode. In this example, the device uses the dedicated  $\overline{\text{DRDY}}$  pin to indicate availability of new conversion data to the host controller.

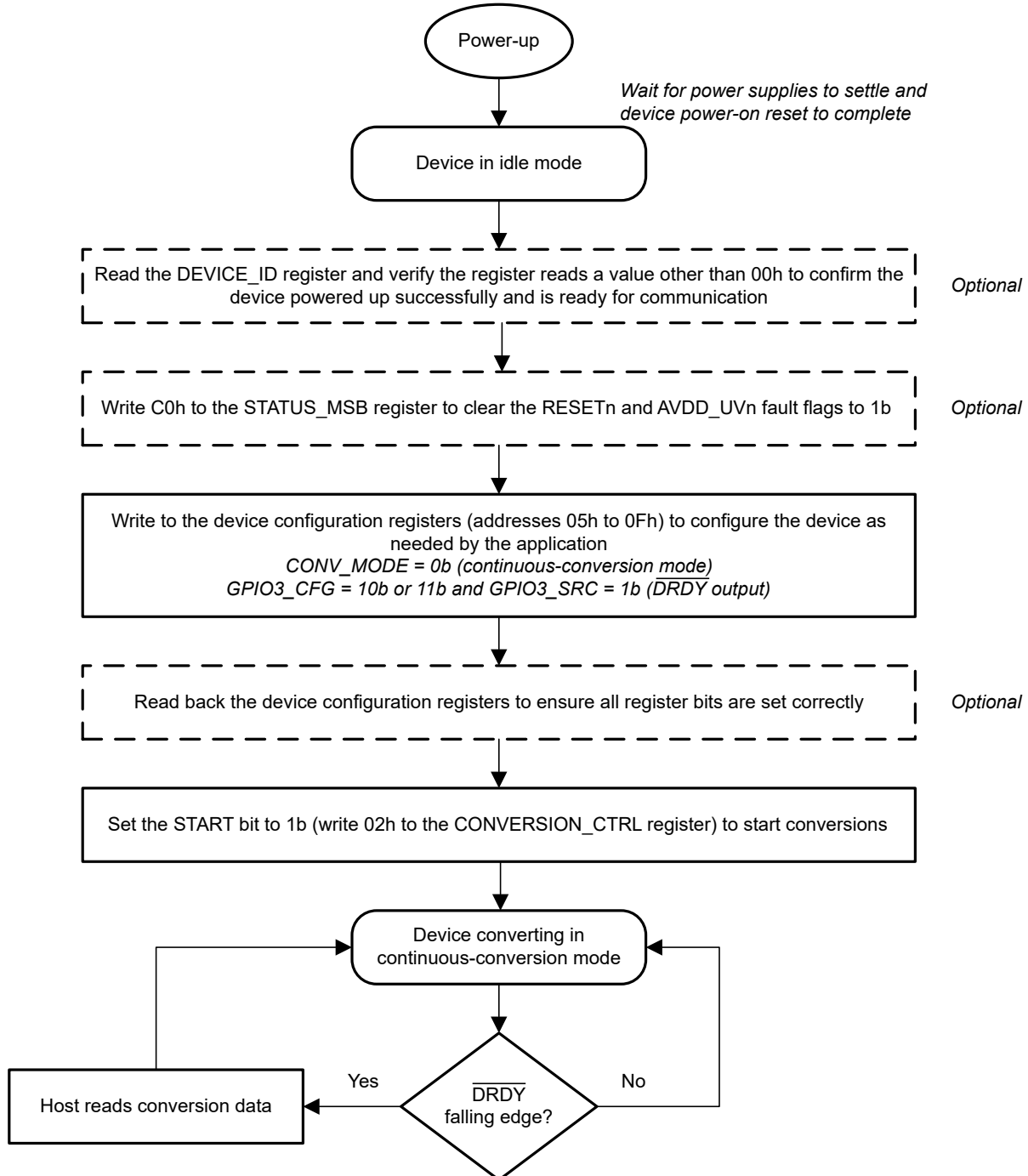

Figure 9-3. Device Initialization Flow Chart

## 9.2 Typical Applications

### 9.2.1 Software-Configurable RTD Measurement Input

The ADS1x2C14 integrate all necessary features (such as excitation current sources, buffered external reference inputs, and a PGA) to implement a ratiometric RTD measurement input module, which accommodates 2-, 3-, and 4-wire RTDs by means of software configuration. Figure 9-4 shows an example implementation for such a software-configurable RTD measurement input module.

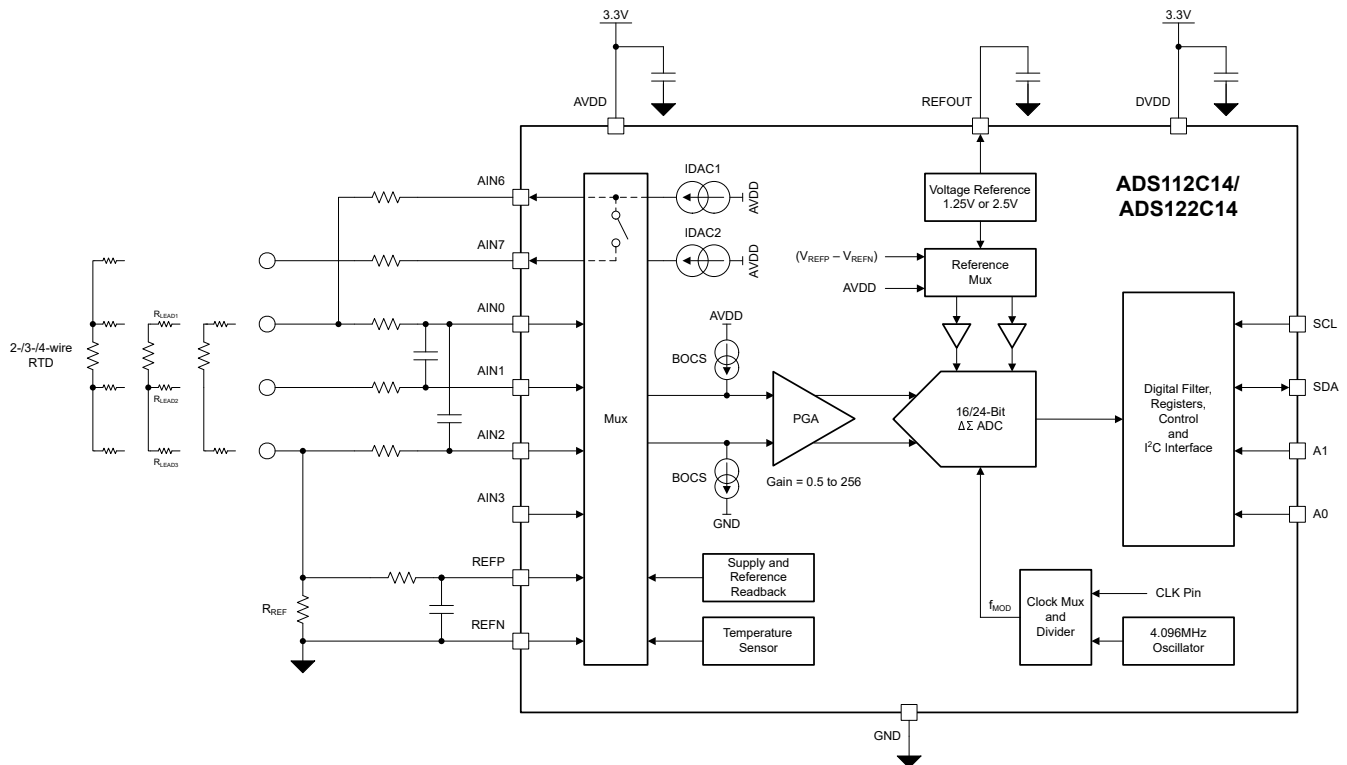

Figure 9-4. Software-Configurable RTD Measurement Input

#### 9.2.1.1 Design Requirements

Table 9-1. Design Parameters

DESIGN PARAMETER	VALUE
Supply voltage	3.3V
Supported RTD types	2-, 3-, 4-wire Pt100
Current consumption	500μA (max)
Temperature measurement range	-200°C to +850°C
Measurement accuracy at $T_A = 25^\circ\text{C}$	$\pm 0.1^\circ\text{C}$
Line-cycle rejection at 50Hz or 60Hz ( $\pm 1\text{Hz}$ )	80dB (min)
Maximum overvoltage at the RTD terminals	$\pm 10\text{V}$

#### 9.2.1.2 Detailed Design Procedure

The circuit in Figure 9-4 employs a ratiometric measurement configuration. In other words, the sensor signal (that is, the voltage across the RTD in this case) and the reference voltage for the ADC are derived from the same excitation source. Therefore, errors resulting from temperature drift or noise of the excitation source cancel because these errors are common to both the sensor signal and the reference.

To implement a ratiometric RTD measurement using the device, route IDAC1 to either AIN7 (for a 4-wire RTD connection) or to AIN6 (for 2- and 3-wire RTD connections) using the I1MUX[2:0] bits. Select the excitation current source value using the I1MAG[3:0] bits. The excitation current flows through the RTD and a precision, low-drift reference resistor,  $R_{REF}$  to ground. The voltage,  $V_{REF}$ , generated across the reference resistor (as shown in Equation 13) is used as the ADC reference voltage. For that purpose, select the external voltage reference between pins AIN4/REFP and AIN5/REFN using the REF\_SEL[1:0]

$$V_{REF} = I_{IDAC1} \times R_{REF} \quad (13)$$

To simplify the following discussion, the individual lead resistance values of the RTDs ( $R_{LEADx}$ ) are set to zero. As Equation 14 shows, IDAC1 excites the RTD to produce a voltage ( $V_{RTD}$ ) proportional to the temperature-dependent RTD value and the IDAC1 value.

$$V_{RTD} = R_{RTD} \times I_{IDAC1} \quad (14)$$

Select the analog inputs using the AINP[3:0] and AINN[3:0] bits to measure  $V_{RTD}$  based on the RTD type:

- For a 2-wire RTD, measure between  $AIN_P = AIN0$  and  $AIN_N = AIN2$ .
- For a 3- or 4-wire RTD, measure between  $AIN_P = AIN0$  and  $AIN_N = AIN1$ .

The device internally amplifies the voltage across the RTD using the PGA and compares the resulting voltage against the reference voltage to produce a digital output code according to Equation 15.

$$\text{Code} / 2^n = V_{RTD} \times \text{Gain} / V_{REF} = (R_{RTD} \times I_{IDAC1} \times \text{Gain}) / (I_{IDAC1} \times R_{REF}) \quad (15)$$

$$\text{Code} / 2^n = (R_{RTD} \times \text{Gain}) / R_{REF} \quad (16)$$

Where n depends on the selected coding scheme and the ADC resolution:

- n = 15 (16bit ADC, binary two's complement format)
- n = 16 (16bit ADC, unipolar straight binary format)
- n = 23 (24bit ADC, binary two's complement format)
- n = 24 (24bit ADC, unipolar straight binary format)

As shown in Equation 16, the output code only depends on the value of the RTD, the PGA gain, and the reference resistor ( $R_{REF}$ ), but not on the IDAC1 value. The absolute accuracy and temperature drift of the excitation current therefore does not matter. However, because the value of the reference resistor directly affects the measurement result, choosing a reference resistor with good initial accuracy and very low temperature coefficient is important to limit measurement errors introduced by  $R_{REF}$ .

The reference resistor  $R_{REF}$  not only serves to generate the reference voltage for the device, but also sets the voltages at the leads of the RTD to within the specified absolute input voltage range of the PGA. This is important in case PGA gains greater than 10 are used, because the PGA needs headroom from GND to operate when using gains greater than 10.

When designing the circuit, care must also be taken to meet the compliance voltage requirement of the IDAC. The IDAC requires that the maximum voltage drop developed across the current path to GND be equal to or less than the specified compliance voltage to operate accurately.

As stated in the Design Requirements, this design example discusses the circuit implementation for a Pt100 element measuring temperatures ranging from  $-200^{\circ}\text{C}$  to  $+850^{\circ}\text{C}$ . The excitation current for the Pt100 is chosen as  $I_{IDAC1} = 400\mu\text{A}$  to meet the required power budget of this example. As mentioned previously, besides creating the reference voltage for the ADC, the voltage across  $R_{REF}$  also sets the absolute input voltages for the RTD measurement. In general, select the largest reference voltage possible that maintains the compliance voltage of the IDAC and meets the absolute input voltage requirement of the PGA. Setting the common-mode voltage at or below half the analog supply is a good starting point for a design. 1.6V is used as the target common-mode voltage in this example. Consequently, use Equation 17 to calculate the value for  $R_{REF}$ :

$$R_{REF} = V_{REF} / I_{IDAC1} = 1.6\text{V} / 400\mu\text{A} = 4\text{k}\Omega \quad (17)$$

The stability of  $R_{REF}$  is critical to achieve good measurement accuracy over temperature and time. Choosing a reference resistor with a temperature coefficient of  $\pm 10\text{ppm}/^\circ\text{C}$  or better is advisable.

As a last step, select the PGA gain to match the maximum input signal to the FSR of the ADC. The resistance of a Pt100 increases with temperature. Therefore, the maximum voltage to be measured ( $V_{INMAX}$ ) occurs at the positive temperature extreme. At  $850^\circ\text{C}$ , a Pt100 has an equivalent resistance of approximately  $391\Omega$  as per the NIST tables. The voltage across the Pt100 equates to [Equation 18](#):

$$V_{INMAX} = V_{RTD} \text{ (at } 850^\circ\text{C)} = R_{RTD} \text{ (at } 850^\circ\text{C)} \times I_{IDAC1} = 391\Omega \times 400\mu\text{A} = 156.4\text{mV} \quad (18)$$

The maximum gain that can be applied when using a 1.6V reference is then calculated as  $(1.6\text{V} / 156.4\text{mV}) = 10.23$ . The next smaller PGA gain setting available in the ADS1x2C14 is 10. At a gain of 10, the device offers an FSR value as described in [Equation 19](#):

$$\text{FSR} = \pm V_{REF} / \text{Gain} = \pm 1.6\text{V} / 10 = \pm 160\text{mV} \quad (19)$$

This range allows for margin with respect to initial accuracy and drift of the IDACs and reference resistor.

To keep the ADC power consumption at a minimum, speed mode 0 ( $f_{MOD} = 32\text{kHz}$ ) is selected using the SPEED\_MODE[1:0] bits. And to meet the line-cycle rejection requirement at 50Hz and 60Hz, the 20SPS output data rate is chosen using the FLTR\_OSR[2:0] bits. The measurement *resolution* (determined by the ADC noise) increases at the expense of higher power consumption, when choosing a faster speed mode with the same 20SPS output data rate setting. However the measurement *accuracy* (determined by the ADC DC errors, such as gain and offset error) is largely unaffected by the speed mode setting.

The primary purpose of the series resistors at the analog and positive reference inputs is to protect the device inputs from any overvoltage conditions. In case overvoltage conditions at the RTD terminals can occur in the application, select the series resistor value such that the currents into the analog and positive reference inputs get limited to less than 10mA. Series resistor values of  $2.2\text{k}\Omega$  are chosen in this example to limit the input currents to less than 5mA when overvoltages up to  $\pm 10\text{V}$  are present at the RTD terminals. Consider the interaction of the series resistors with the input currents into the analog and reference inputs when selecting the resistor values. The voltage drop created across the series resistors causes a potential offset error. In addition, the series resistors together with the input capacitors form first order RC antialiasing filters. The exact corner frequency of the RC filters is not very critical with this delta-sigma ADC. A general recommendation is to select a corner frequency which is at least 10 times lower than the modulator frequency of the ADC.

After selecting the values for the IDAC,  $R_{REF}$ , PGA gain, and the series resistors, make sure to double check that the settings meet the absolute input voltage requirements of the PGA and the compliance voltage of the IDAC. Include the voltage drop created by IDAC1 across the RTD lead resistances and the series resistor at the IDAC1 output pin in the calculations.

Lead-wire compensation for 3-wire RTDs in this example is achieved by implementing a two-step measurement approach.

1. In step one, measure the voltage ( $V_1$ ) between AIN0 and AIN1.
2. In a second measurement step, measure the voltage ( $V_2$ ) between AIN0 and AIN2.

[Equation 20](#) and [Equation 21](#) represent the two measurements.

$$V_1 = I_{IDAC1} (R_{LEAD1} + R_{RTD}) \quad (20)$$

$$V_2 = I_{IDAC1} (R_{LEAD1} + R_{RTD} + R_{LEAD3}) \quad (21)$$

To assume that all three lead resistances have the same value,  $R_{LEAD}$ , is reasonable. Consequently, use [Equation 22](#) to calculate the lead-wire compensated RTD voltage.

$$V_{RTD} = 2 \times V_1 - V_2 = 2 \times [I_{IDAC1} (R_{LEAD} + R_{RTD})] - I_{IDAC1} (2 \times R_{LEAD} + R_{RTD}) = I_{IDAC1} \times R_{RTD} \quad (22)$$

RTD Measurement Register Bit Settings shows the critical register bit settings for the various measurements in this design example.

**Table 9-2. RTD Measurement Register Bit Settings**

REGISTER BITS	2-WIRE RTD	3-WIRE RTD		4-WIRE RTD
		V <sub>1</sub>	V <sub>2</sub>	
SPEED_MODE[1:0]		00b (Speed Mode 0)		
FLTR_OSR[2:0]		111b (f <sub>DATA</sub> = 20SPS)		
GAIN[3:0]		0110b (Gain = 10)		
REFP_BUF_EN		1b (REFP buffer enabled)		
REFN_BUF_EN		0b (REFN buffer disabled)		
REF_SEL[1:0]		01b (External reference)		
IUNIT		1b (IUNIT = 10µA)		
I2MAG[3:0]		0000b (IDAC2 disabled)		
I2MUX[2:0]		Don't care		
I1MAG[3:0]		0101b (I <sub>IDAC1</sub> = 40 × IUNIT)		
I1MUX[2:0]	110b (AIN6)	110b (AIN6)	110b (AIN6)	111b (AIN7)
AINP[3:0]	0000b (AIN0)	0000b (AIN0)	0000b (AIN0)	0000b (AIN0)
AINN[3:0]	0010b (AIN2)	0001b (AIN1)	0010b (AIN2)	0001b (AIN1)

For more information about RTD measurement circuits and the implementation using TI ADCs see the [A Basic Guide to RTD Measurements](#) application note. Various strategies for sensor fault detection using features similar to the ones integrated in ADS1x2C14 are discussed in the [RTD Wire-Break Detection Using Precision Delta-Sigma ADCs](#) application note. A software library using C code showing how to implement the RTD linearization algorithm in the host controller is available [here](#).

### 9.2.1.3 Application Performance Plots

Figure 9-5 and Figure 9-6 show the measurement results for a 4-wire Pt100. The measurements are taken at T<sub>A</sub> = 25°C using precision resistors instead of a 4-wire Pt100. Figure 9-5 shows both the resistance measurement error without any calibration and after a system offset and gain calibration. The respective temperature measurement error in Figure 9-6 is calculated from the offset and gain error corrected data in Figure 9-5 using the NIST tables.

The design meets the required temperature measurement accuracy given in the [Design Requirements](#). However, the measurement error shown in Figure 9-6 does not include the error of the RTD.

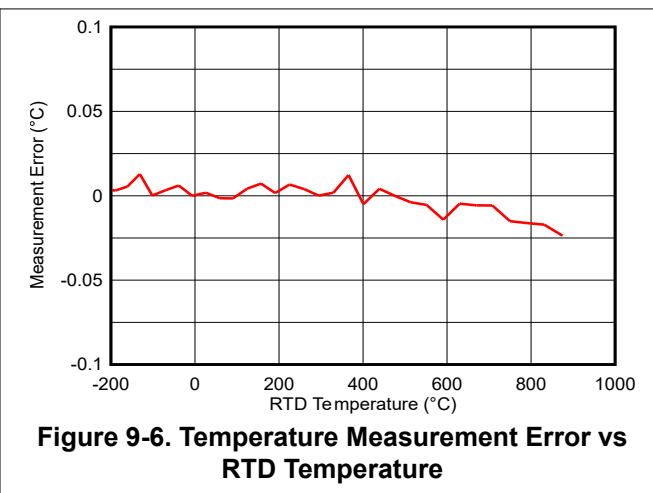
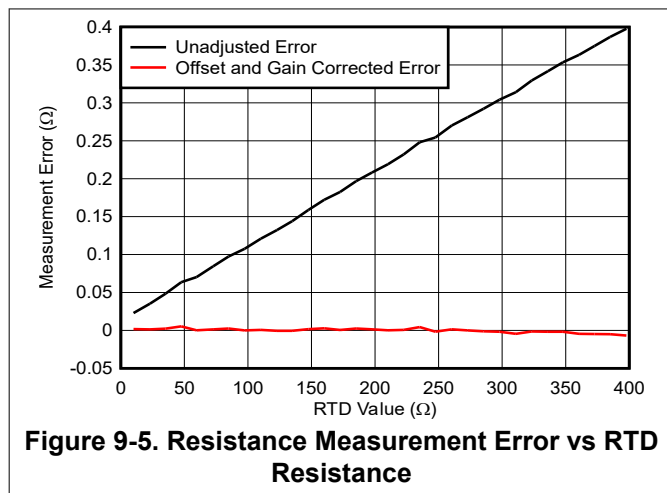

### 9.2.1.4 Design Variant – 3-Wire RTD Measurement With Automatic Lead-Wire Compensation Using Two IDACs

The circuit implementation shown in Figure 9-4 requires two measurements to compensate for the lead-wire resistance of a 3-wire RTD. Alternatively, leverage the second IDAC to implement automatic 3-wire RTD lead-wire compensation as shown in Figure 9-7, which does not require a separate lead wire resistance measurement step.

For that purpose, route IDAC2 to AIN3 and connect AIN3 to the point where the terminal connects to the series resistor in front of AIN1. Change both excitation current values from 400µA to 200µA (or the reference resistor value from 4kΩ to 2kΩ) in this configuration and the PGA gain from 10 to 20. A single measurement between AIN0 and AIN1 is sufficient to get a lead-wire compensated RTD value. Use Equation 23 to calculate the resistance of the 3-wire RTD in this implementation.

$$\text{Code} / 2^n = (R_{\text{RTD}} \times \text{Gain}) / (2 \times R_{\text{REF}}) \quad (23)$$

Where n follows the guidelines of Equation 16.

For more details see the *A Basic Guide to RTD Measurements* application note.

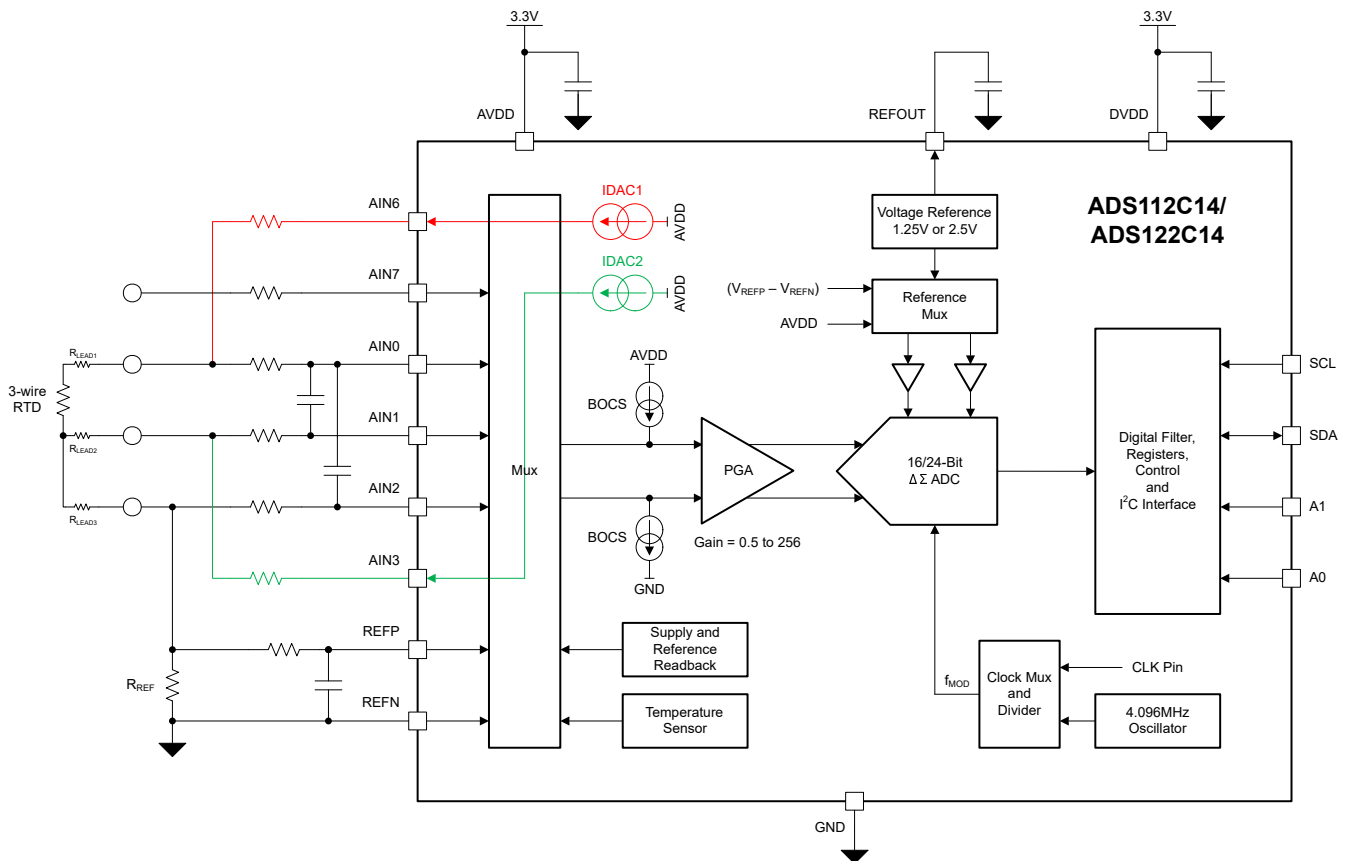

Figure 9-7. 3-wire RTD Measurement Implementation Using Two IDACs for Automatic Lead-Wire Compensation

### 9.2.2 Thermocouple Measurement With Cold-Junction Compensation Using a 2-wire RTD

Figure 9-8 shows the implementation of a thermocouple measurement using a 2-wire RTD for cold-junction temperature measurement. Other ways to measure the cold-junction temperature can be used with the ADS1x2C14 as well, such as a thermistor (for example TMP61), an analog output temperature sensor (for example LMT70A), or using the integrated temperature sensor.

Equation 24 provides the relationship between ADC codes and the thermocouple voltage ( $V_{TC}$ ) measured between AIN0 and AIN1.

$$\text{Code} / 2^n = (V_{TC} \times \text{Gain}) / V_{REF} \quad (24)$$

Where n follows the guidelines of Equation 16.

An important aspect of the circuit implementation is the biasing of the thermocouple so that the voltages at the thermocouple terminals meet the input voltage requirements of the ADS1x2C14. In this example pullup and pulldown resistors (typically in the range of 1MΩ to 10MΩ) in front of the RC filter are used to bias the thermocouple output voltage to  $AVDD / 2$ . At the same time, the pullup and pulldown resistors serve as a means to detect an open sensor connection. In case of an open sensor connection, the positive analog input (AIN0) is pulled to AVDD, and the negative analog input (AIN1) to GND. This condition leads to a measurement result which is outside the normal measurement range for the thermocouple.

Many other ways to bias the thermocouple can be used as well. For example the reference output voltage can be used by connecting REFOUT to the negative thermocouple terminal instead of the pulldown resistor. For more information about thermocouple measurement circuits and the implementation using TI ADCs see the [Basic Guide to Thermocouple Measurements](#) application note. A software library using C code showing how to implement the thermocouple linearization and cold-junction compensation algorithms in the host controller is available [here](#).

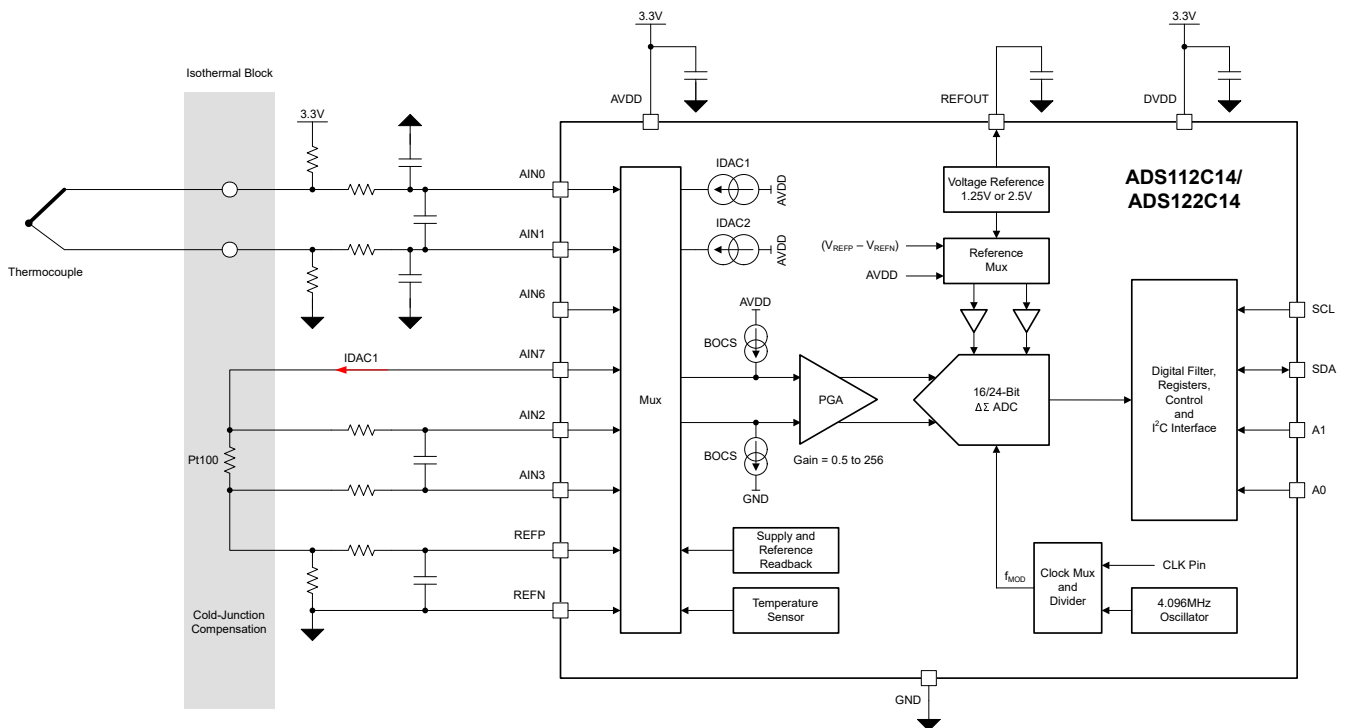

Figure 9-8. Thermocouple Measurement With Cold-Junction Compensation Using a 2-wire RTD

### 9.2.3 Resistive Bridge Sensor Measurement With Temperature Compensation

Figure 9-9 and Figure 9-10 show two examples of how to implement a resistive bridge sensor measurement with temperature compensation using the ADS1x2C14. The bridge temperature is typically used in the host controller to compensate for the bridge temperature drift.

The circuit implementation in Figure 9-9 uses the analog supply to excite the bridge sensor. Use the bridge excitation voltage as the external reference voltage for the ADC to implement a *ratiometric* bridge measurement. Instead of the analog supply, one of the integrated excitation current sources can be used to excite the bridge as well. Equation 25 through Equation 27 show how to derive the relationship between ADC output codes and the applied bridge signal using a pressure sensor as an example. Equation 27 shows that the output codes are independent of the excitation voltage in this ratiometric circuit implementation.

$$V_{\text{Bridge}} = V_{\text{AIN2}} - V_{\text{AIN3}} = (\text{Pressure}_{\text{APL}} / \text{Pressure}_{\text{MAX}}) \times \text{Sensitivity} \times V_{\text{Excitation}} \quad (25)$$

$$\text{Code} / 2^n = V_{\text{Bridge}} \times \text{Gain} / V_{\text{REF}} \quad (26)$$

$$\text{Code} / 2^n = (\text{Pressure}_{\text{APL}} / \text{Pressure}_{\text{MAX}}) \times \text{Sensitivity} \times \text{Gain} \quad (27)$$

Where:

- $V_{\text{Excitation}} = V_{\text{REF}} = \text{AVDD}$
- $\text{Pressure}_{\text{APL}}$  = the applied pressure
- $\text{Pressure}_{\text{MAX}}$  = the maximum capacity of the pressure sensor. Means the pressure where the bridge sensor outputs the full-scale output signal
- Sensitivity = the sensitivity of the bridge sensor typically given in mV/V of bridge excitation
- n follows the guidelines of Equation 16

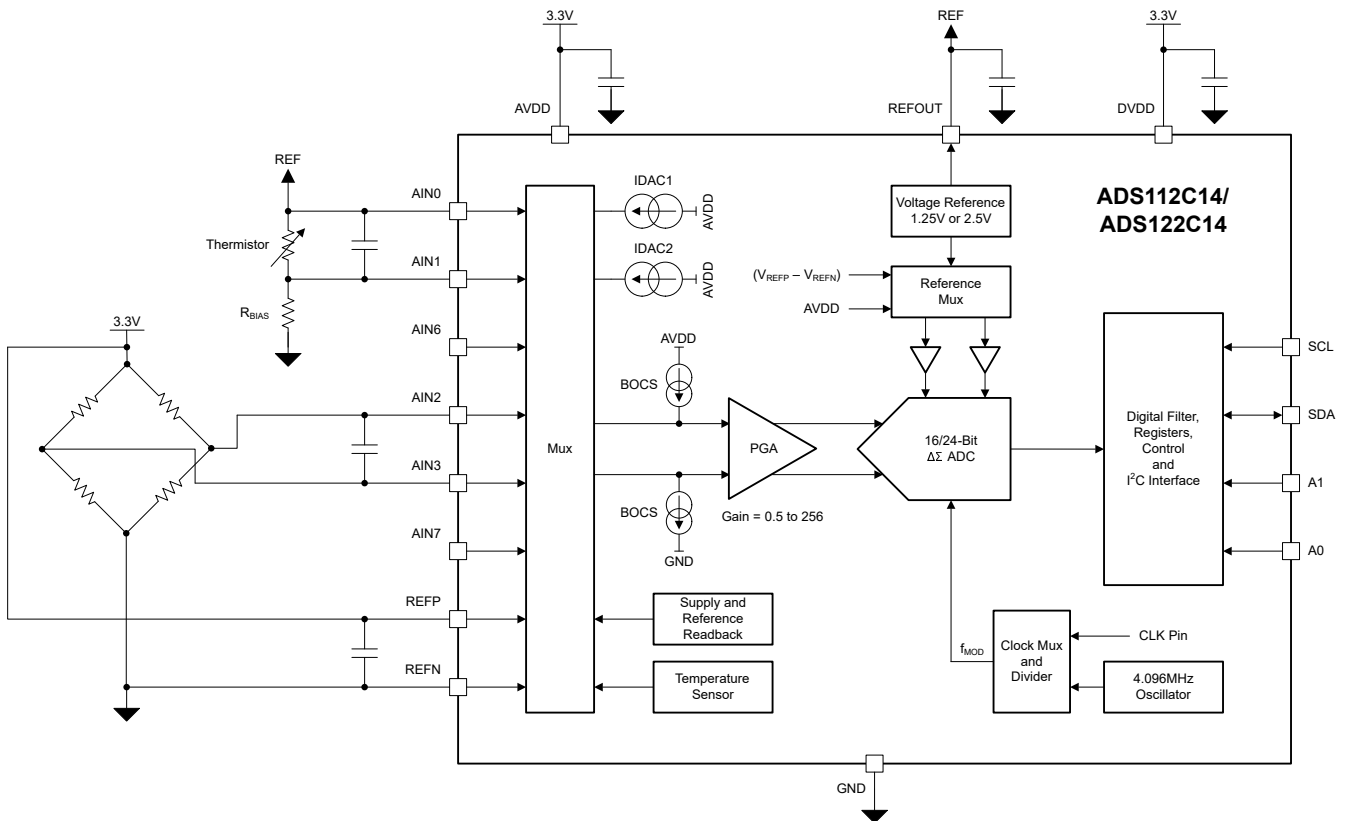

**Figure 9-9. Resistive Bridge Sensor Measurement Example 1**  
(Using the Analog Supply as Bridge Excitation and a Thermistor for Bridge Temperature Measurement)

The example shows a thermistor to measure the bridge temperature. The reference voltage output is used in this case to implement a *ratiometric* thermistor measurement. The conversion result according to Equation 29 is only dependent on the bias resistor ( $R_{BIAS}$ ) and the PGA gain setting.

$$V_{Thermistor} = V_{AIN0} - V_{AIN1} = V_{REF} \times R_{Thermistor} / (R_{Thermistor} + R_{BIAS}) \quad (28)$$

$$Code / 2^n = (V_{Thermistor} \times Gain) / V_{REF} = (R_{Thermistor} \times Gain) / (R_{Thermistor} + R_{BIAS}) \quad (29)$$

Where n follows the guidelines of Equation 16.

Figure 9-10 shows an alternative circuit implementation where the reference output is used to excite the bridge and the measurement of the temperature-dependent bridge resistance (measurement between AIN0 and AIN3) is used to determine the bridge temperature. Similar to the thermistor measurement above, the bridge resistance measurement is ratiometric and only dependent on the bias resistor and the PGA gain setting as shown in Equation 30.

$$Code / 2^n = (R_{Bridge} \times Gain) / (R_{Bridge} + R_{BIAS}) \quad (30)$$

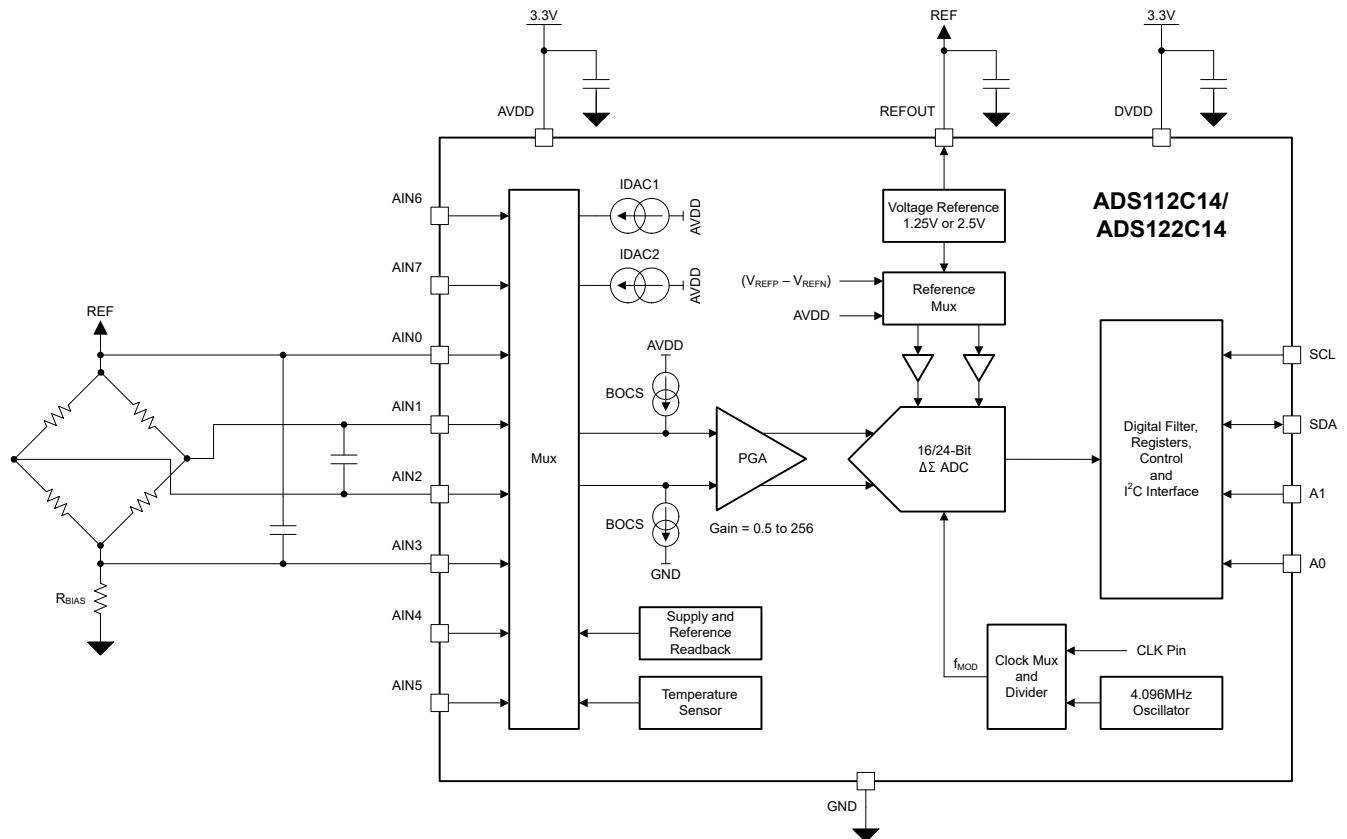

**Figure 9-10. Resistive Bridge Sensor Measurement Example 2  
(Using the Reference Output as Bridge Excitation and the Bridge Resistance as Temperature Measurement)**

Use one of the GPIO outputs to control a switch placed between the bridge sensor and GND for applications where the bridge sensor needs to be powered down periodically to save power.

For more information about resistive bridge sensor measurement circuits and the implementation using TI ADCs see the [A Basic Guide to Bridge Measurements](#) application note.

## 9.3 Power Supply Recommendations

### 9.3.1 Power Supplies

The device requires two power supplies: analog (AVDD) and digital (DVDD). The analog power supply can be independently chosen from the digital power supply. The DVDD supply sets the logic levels for the serial interface pins (SCL, SDA, A0, A1). The AVDD supply sets the logic levels for the GPIOs (GPIO0 to GPIO3).

### 9.3.2 Power-Supply Sequencing

The power supplies can be sequenced in any order, but in no case must any analog or digital inputs exceed the respective analog or digital power-supply voltage and current limits. Wait  $t_{d(POR)}$  after the DVDD supply stabilized before communicating with the device to allow the power-on reset process to complete.

### 9.3.3 Power-Supply Decoupling

Good power-supply decoupling is important to achieve optimum device performance. As shown in [Figure 9-11](#), AVDD and DVDD must each be decoupled with at least a 100nF capacitor to GND. Place the supply bypass capacitors as close to the device power-supply pins as possible using low-impedance connections. Use multi-layer ceramic chip capacitors (MLCCs) that offer low equivalent series resistance (ESR) and inductance (ESL) characteristics for power-supply decoupling purposes. For very sensitive systems, or for systems in harsh noise environments, avoiding the use of vias for connecting the capacitors to the device pins can offer enhanced noise immunity. The use of multiple vias in parallel lowers the overall inductance and is beneficial for connections to ground planes.

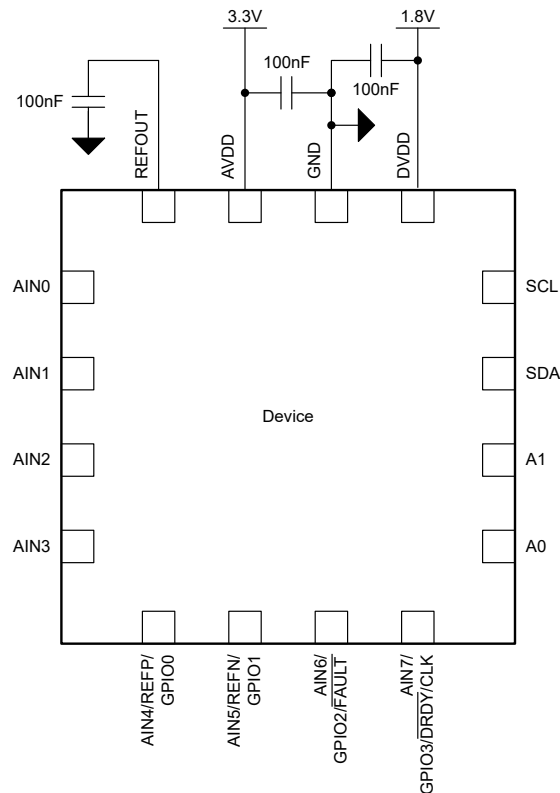

**Figure 9-11. Power Supply Decoupling**

## 9.4 Layout

### 9.4.1 Layout Guidelines

The following basic recommendations for the ADS1x2C14 layout help achieve the best possible performance of the ADC.

- For best performance, dedicate an entire PCB layer to a ground plane and do not route any other signal traces on this layer.
- Use ceramic capacitors (for example, X7R grade) for the power-supply decoupling capacitors. High-K capacitors (Y5V) are not recommended. Place the required capacitors as close as possible to the device pins using short, direct traces. Placing the bypass capacitors on the same layer as close to the device yields the best results.
- Route digital traces away from all analog inputs and associated components to minimize interference.
- Provide good ground return paths. Signal return currents flow on the path of least impedance. If the ground plane is cut or has other traces that block the current from flowing right next to the signal trace, another path must be found to return to the source and complete the circuit. If forced into a larger path, the chance that the signal radiates increases. Sensitive signals are more susceptible to EMI interference.
- Consider the resistance and inductance of the routing. Often, traces for the inputs have resistances that react with the input bias current and cause an added error voltage. Reducing the loop area enclosed by the source signal and the return current reduces the inductance in the path. Reducing the inductance reduces the EMI pickup and reduces the high-frequency impedance at the input of the device.
- Watch for parasitic thermocouples in the layout. Dissimilar metals going from each analog input to the sensor can create a parasitic thermocouple that can add an offset to the measurement. Differential inputs must be matched for both the inputs going to the measurement source.
- Use C0G capacitors for the RC filters on the analog inputs.
- Fill void areas on signal layers with ground fill.
- When applying an external clock, be sure the clock is free of overshoot and glitches. A source-termination resistor placed at the clock buffer often helps reduce overshoot. Glitches present on the clock input can lead to noise within the conversion data.

### 9.4.2 Layout Example

Figure 9-12 shows a basic layout example for the ADS1x2C14:

- C1 is the required capacitor at the REFOUT pin to GND. Place C1 as close as possible to the REFOUT pin.
- C2 and C3 are the power supply decoupling capacitors. Place C2 and C3 as close as possible to the respective supply pins.
- Connect the GND pin through the decoupling capacitors to the ground plane.
- Differential antialiasing RC-filters are shown for the differential analog input pairs AIN0-AIN1, AIN2-AIN3 and AIN4-AIN5, respectively.
- R5 and R6 are the I<sup>2</sup>C bus pullup resistors.

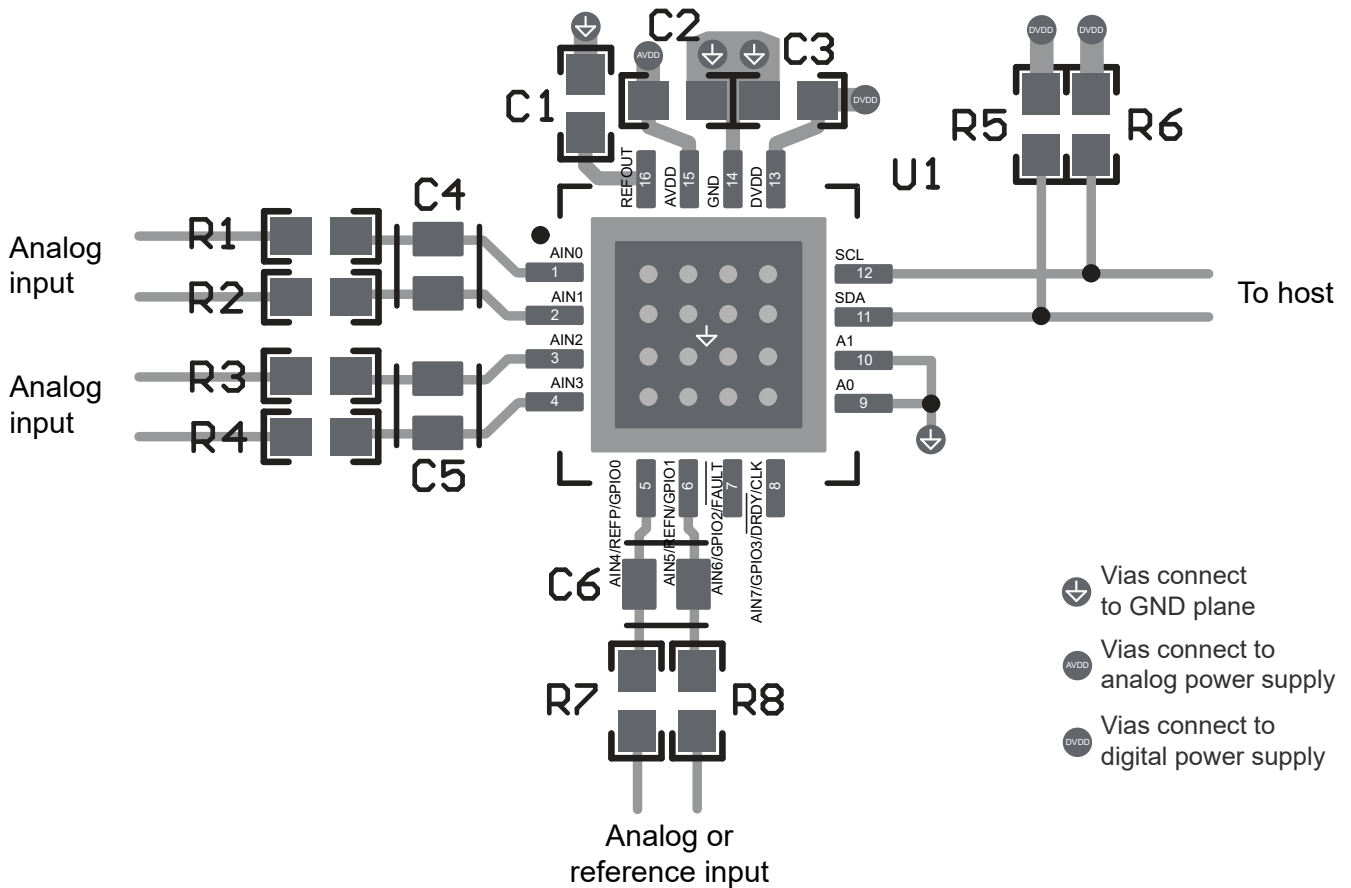

**Figure 9-12. Layout Example**

## 10 Device and Documentation Support

TI offers an extensive line of development tools. Tools and software to evaluate the performance of the device, generate code, and develop solutions are listed below.

### 10.1 Documentation Support

#### 10.1.1 Related Documentation

1. Texas Instruments, [A Basic Guide to RTD Measurements](#) application note
2. Texas Instruments, [RTD Wire-Break Detection Using Precision Delta-Sigma ADCs](#) application note
3. Texas Instruments, [A Basic Guide to Thermocouple Measurements](#) application note
4. Texas Instruments, [A Basic Guide to Bridge Measurements](#) application note
5. Texas Instruments, [Temperature-sensor \(RTD, thermocouple, thermistor\) firmware for precision ADCs](#) tool page

### 10.2 Receiving Notification of Documentation Updates

To receive notification of documentation updates, navigate to the device product folder on [ti.com](http://ti.com). Click on *Notifications* to register and receive a weekly digest of any product information that has changed. For change details, review the revision history included in any revised document.

### 10.3 Support Resources

[TI E2E™ support forums](#) are an engineer's go-to source for fast, verified answers and design help — straight from the experts. Search existing answers or ask your own question to get the quick design help you need.

Linked content is provided "AS IS" by the respective contributors. They do not constitute TI specifications and do not necessarily reflect TI's views; see TI's [Terms of Use](#).

### 10.4 Trademarks

NXP Semiconductors™ is a trademark of NXP Semiconductors.

TI E2E™ is a trademark of Texas Instruments.

All trademarks are the property of their respective owners.

### 10.5 Electrostatic Discharge Caution



This integrated circuit can be damaged by ESD. Texas Instruments recommends that all integrated circuits be handled with appropriate precautions. Failure to observe proper handling and installation procedures can cause damage.

ESD damage can range from subtle performance degradation to complete device failure. Precision integrated circuits may be more susceptible to damage because very small parametric changes could cause the device not to meet its published specifications.

### 10.6 Glossary

[TI Glossary](#) This glossary lists and explains terms, acronyms, and definitions.

## 11 Revision History

NOTE: Page numbers for previous revisions may differ from page numbers in the current version.

DATE	REVISION	NOTES
December 2025	*	Initial Release

## 12 Mechanical, Packaging, and Orderable Information

The following pages include mechanical, packaging, and orderable information. This information is the most current data available for the designated devices. This data is subject to change without notice and revision of this document. For browser-based versions of this data sheet, refer to the left-hand navigation.

**PACKAGING INFORMATION**

Orderable part number	Status (1)	Material type (2)	Package   Pins	Package qty   Carrier	RoHS (3)	Lead finish/ Ball material (4)	MSL rating/ Peak reflow (5)	Op temp (°C)	Part marking (6)
<a href="#">ADS112C14IRTER</a>	Active	Production	WQFN (RTE)   16	3000   LARGE T&R	Yes	NIPDAU	Level-2-260C-1 YEAR	-50 to 125	A12C14
<a href="#">ADS122C14IRTER</a>	Active	Production	WQFN (RTE)   16	3000   LARGE T&R	Yes	NIPDAU	Level-2-260C-1 YEAR	-50 to 125	A22C14

(1) **Status:** For more details on status, see our [product life cycle](#).

(2) **Material type:** When designated, preproduction parts are prototypes/experimental devices, and are not yet approved or released for full production. Testing and final process, including without limitation quality assurance, reliability performance testing, and/or process qualification, may not yet be complete, and this item is subject to further changes or possible discontinuation. If available for ordering, purchases will be subject to an additional waiver at checkout, and are intended for early internal evaluation purposes only. These items are sold without warranties of any kind.

(3) **RoHS values:** Yes, No, RoHS Exempt. See the [TI RoHS Statement](#) for additional information and value definition.

(4) **Lead finish/Ball material:** Parts may have multiple material finish options. Finish options are separated by a vertical ruled line. Lead finish/Ball material values may wrap to two lines if the finish value exceeds the maximum column width.

(5) **MSL rating/Peak reflow:** The moisture sensitivity level ratings and peak solder (reflow) temperatures. In the event that a part has multiple moisture sensitivity ratings, only the lowest level per JEDEC standards is shown. Refer to the shipping label for the actual reflow temperature that will be used to mount the part to the printed circuit board.

(6) **Part marking:** There may be an additional marking, which relates to the logo, the lot trace code information, or the environmental category of the part.

Multiple part markings will be inside parentheses. Only one part marking contained in parentheses and separated by a "~" will appear on a part. If a line is indented then it is a continuation of the previous line and the two combined represent the entire part marking for that device.

**Important Information and Disclaimer:**The information provided on this page represents TI's knowledge and belief as of the date that it is provided. TI bases its knowledge and belief on information provided by third parties, and makes no representation or warranty as to the accuracy of such information. Efforts are underway to better integrate information from third parties. TI has taken and continues to take reasonable steps to provide representative and accurate information but may not have conducted destructive testing or chemical analysis on incoming materials and chemicals. TI and TI suppliers consider certain information to be proprietary, and thus CAS numbers and other limited information may not be available for release.

In no event shall TI's liability arising out of such information exceed the total purchase price of the TI part(s) at issue in this document sold by TI to Customer on an annual basis.

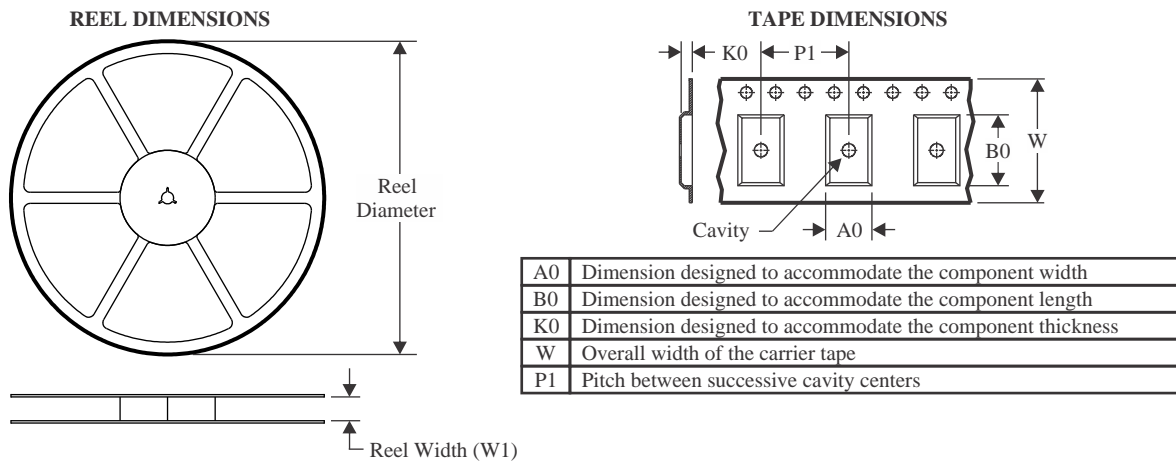
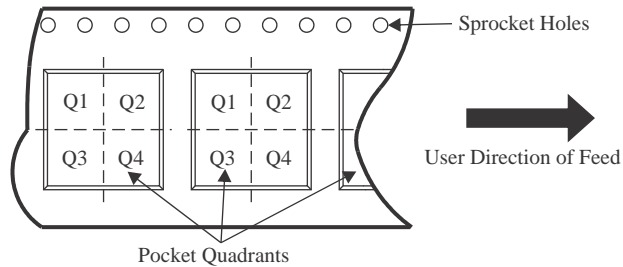
**TAPE AND REEL INFORMATION**

**QUADRANT ASSIGNMENTS FOR PIN 1 ORIENTATION IN TAPE**

\*All dimensions are nominal

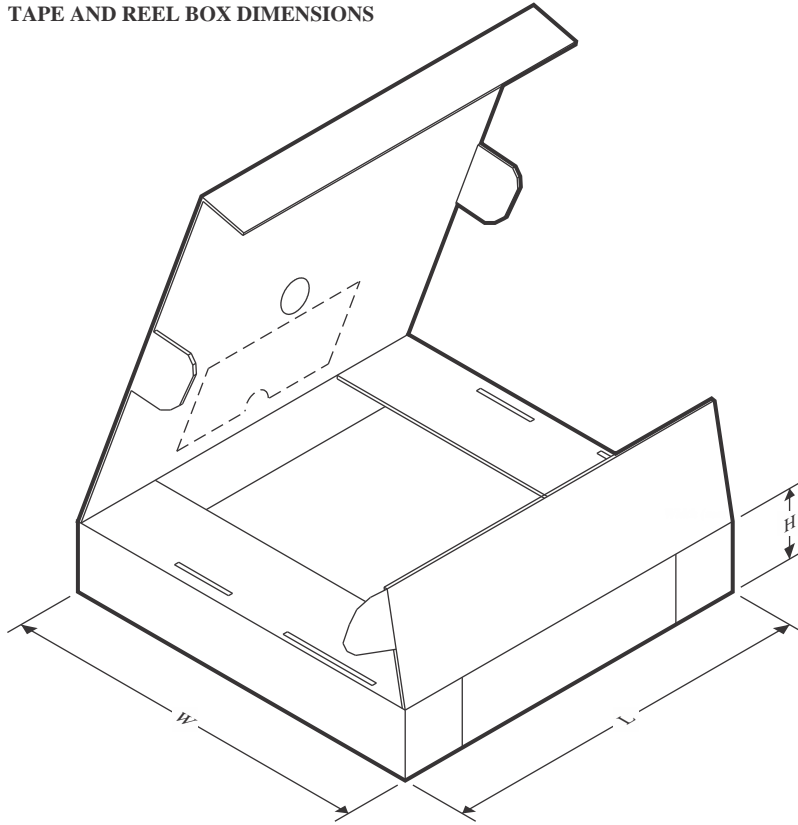
Device	Package Type	Package Drawing	Pins	SPQ	Reel Diameter (mm)	Reel Width W1 (mm)	A0 (mm)	B0 (mm)	K0 (mm)	P1 (mm)	W (mm)	Pin1 Quadrant
ADS122C14IRTER	WQFN	RTE	16	3000	330.0	12.4	3.3	3.3	1.1	8.0	12.0	Q2

**TAPE AND REEL BOX DIMENSIONS**

\*All dimensions are nominal

Device	Package Type	Package Drawing	Pins	SPQ	Length (mm)	Width (mm)	Height (mm)
ADS122C14IRTER	WQFN	RTE	16	3000	367.0	367.0	35.0

## GENERIC PACKAGE VIEW

**RTE 16**

**WQFN - 0.8 mm max height**

3 x 3, 0.5 mm pitch

PLASTIC QUAD FLATPACK - NO LEAD

This image is a representation of the package family, actual package may vary.  
Refer to the product data sheet for package details.

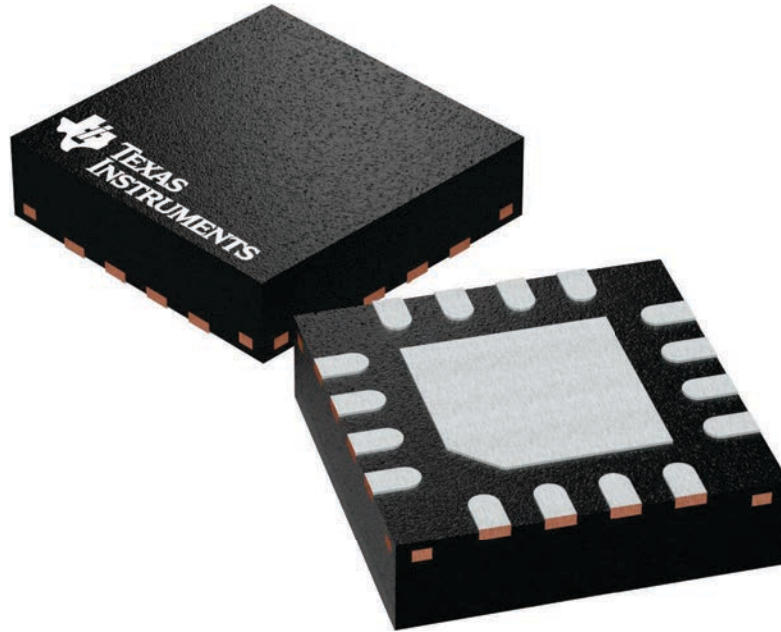

4225944/A

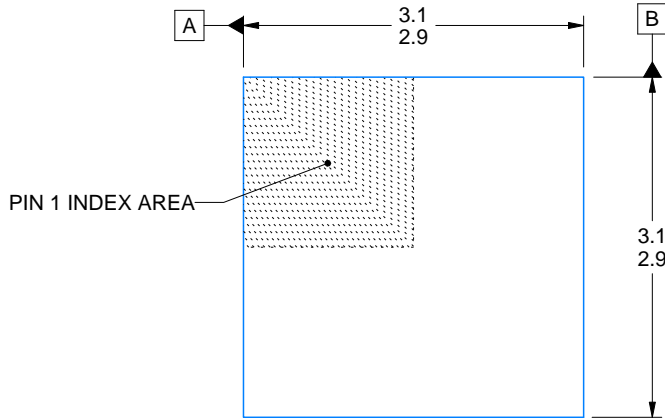

SIDE WALL METAL THICKNESS DIM A	
OPTION 1	OPTION 2
0.1	0.2

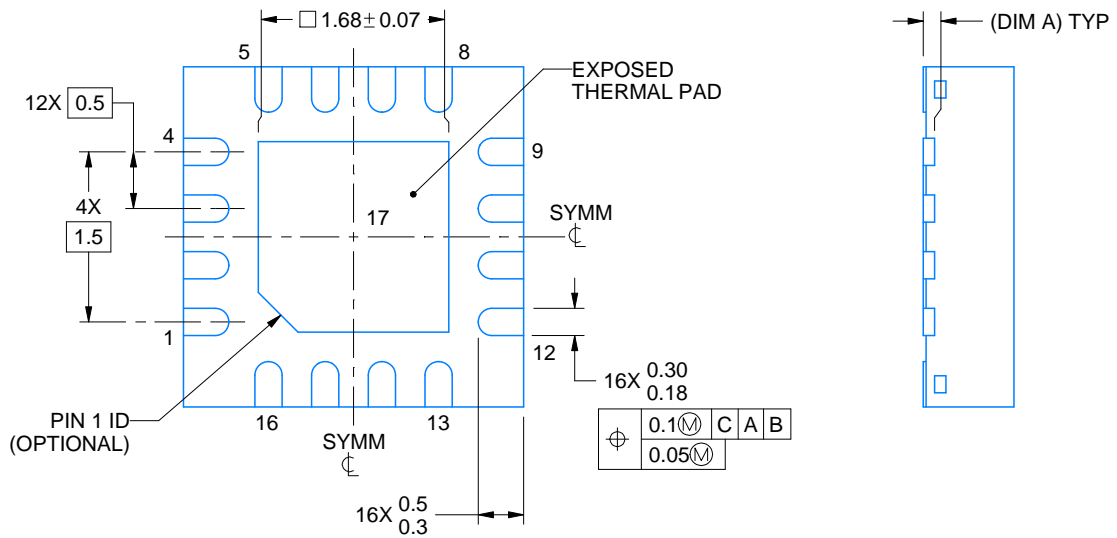
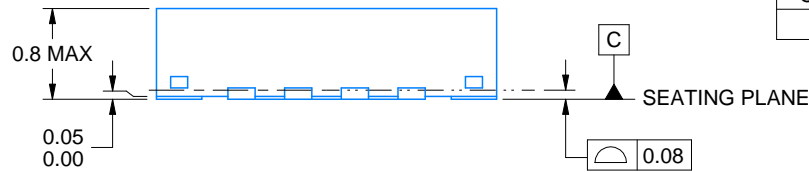

4219117/B 04/2022

NOTES:

1. All linear dimensions are in millimeters. Any dimensions in parenthesis are for reference only. Dimensioning and tolerancing per ASME Y14.5M.
2. This drawing is subject to change without notice.
3. The package thermal pad must be soldered to the printed circuit board for thermal and mechanical performance.

# EXAMPLE BOARD LAYOUT

RTE0016C

WQFN - 0.8 mm max height

PLASTIC QUAD FLATPACK - NO LEAD

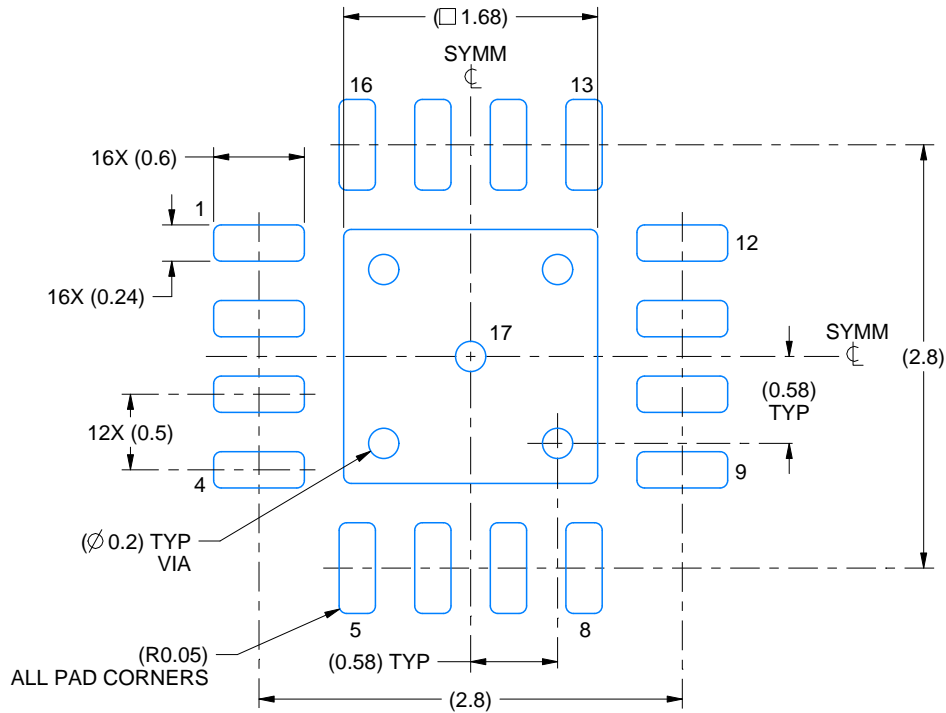

LAND PATTERN EXAMPLE  
EXPOSED METAL SHOWN  
SCALE:20X

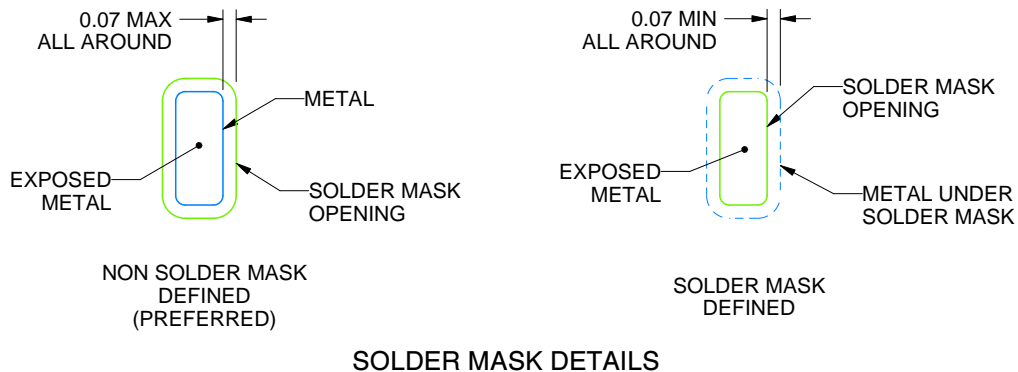

SOLDER MASK DETAILS

4219117/B 04/2022

NOTES: (continued)

- This package is designed to be soldered to a thermal pad on the board. For more information, see Texas Instruments literature number SLUA271 ([www.ti.com/lit/slua271](http://www.ti.com/lit/slua271)).
- Vias are optional depending on application, refer to device data sheet. If any vias are implemented, refer to their locations shown on this view. It is recommended that vias under paste be filled, plugged or tented.

# EXAMPLE STENCIL DESIGN

RTE0016C

WQFN - 0.8 mm max height

PLASTIC QUAD FLATPACK - NO LEAD

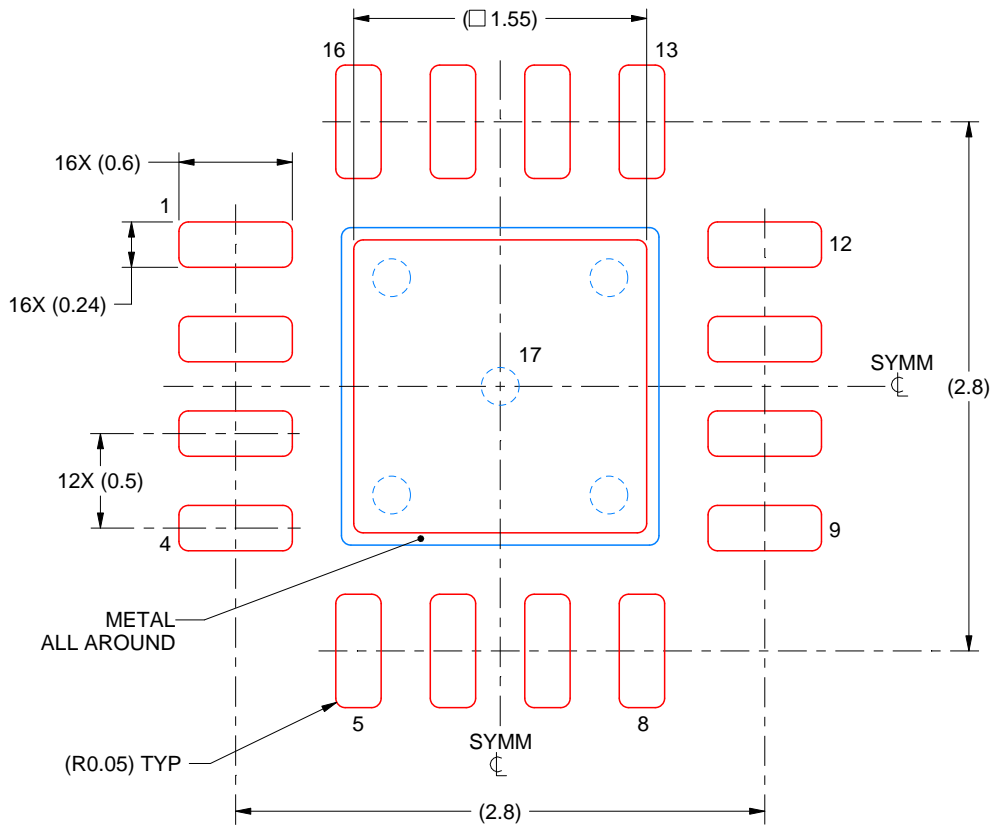

**SOLDER PASTE EXAMPLE**  
BASED ON 0.125 mm THICK STENCIL

EXPOSED PAD 17:  
85% PRINTED SOLDER COVERAGE BY AREA UNDER PACKAGE  
SCALE:25X

4219117/B 04/2022

NOTES: (continued)

6. Laser cutting apertures with trapezoidal walls and rounded corners may offer better paste release. IPC-7525 may have alternate design recommendations.

## IMPORTANT NOTICE AND DISCLAIMER

TI PROVIDES TECHNICAL AND RELIABILITY DATA (INCLUDING DATASHEETS), DESIGN RESOURCES (INCLUDING REFERENCE DESIGNS), APPLICATION OR OTHER DESIGN ADVICE, WEB TOOLS, SAFETY INFORMATION, AND OTHER RESOURCES "AS IS" AND WITH ALL FAULTS, AND DISCLAIMS ALL WARRANTIES, EXPRESS AND IMPLIED, INCLUDING WITHOUT LIMITATION ANY IMPLIED WARRANTIES OF MERCHANTABILITY, FITNESS FOR A PARTICULAR PURPOSE OR NON-INFRINGEMENT OF THIRD PARTY INTELLECTUAL PROPERTY RIGHTS.

These resources are intended for skilled developers designing with TI products. You are solely responsible for (1) selecting the appropriate TI products for your application, (2) designing, validating and testing your application, and (3) ensuring your application meets applicable standards, and any other safety, security, regulatory or other requirements.

These resources are subject to change without notice. TI grants you permission to use these resources only for development of an application that uses the TI products described in the resource. Other reproduction and display of these resources is prohibited. No license is granted to any other TI intellectual property right or to any third party intellectual property right. TI disclaims responsibility for, and you fully indemnify TI and its representatives against any claims, damages, costs, losses, and liabilities arising out of your use of these resources.

TI's products are provided subject to [TI's Terms of Sale](#), [TI's General Quality Guidelines](#), or other applicable terms available either on [ti.com](http://ti.com) or provided in conjunction with such TI products. TI's provision of these resources does not expand or otherwise alter TI's applicable warranties or warranty disclaimers for TI products. Unless TI explicitly designates a product as custom or customer-specified, TI products are standard, catalog, general purpose devices.

TI objects to and rejects any additional or different terms you may propose.

Copyright © 2026, Texas Instruments Incorporated

Last updated 10/2025