

# AMC1303x Small, High-Precision, Reinforced Isolated Delta-Sigma Modulators With Internal Clock

## 1 Features

- Pin-compatible family optimized for shunt-resistor-based current measurements:
  - $\pm 50\text{mV}$  or  $\pm 250\text{mV}$  input voltage ranges
  - Manchester-coded or uncoded bitstream options
  - 10MHz and 20MHz clock options
- Excellent DC performance:
  - Offset error:  $\pm 50\mu\text{V}$  or  $\pm 100\mu\text{V}$  (max)
  - Offset drift:  $\pm 1\mu\text{V}/^\circ\text{C}$  (max)
  - Gain error:  $\pm 0.2\%$  (max)
  - Gain drift:  $\pm 40\text{ppm}/^\circ\text{C}$  (max)
- Transient immunity: 100kV/ $\mu\text{s}$  (typ)
- System-level diagnostic features
- Safety-related certifications:
  - 7000V<sub>PK</sub> reinforced isolation per DIN EN IEC 60747-17 (VDE 0884-17)
  - 5000V<sub>RMS</sub> isolation for 1 minute per UL1577
  - CAN/CSA no. 5A-component acceptance service notice and IEC 62368-1 end equipment standard
- Fully specified over the extended industrial temperature range:  $-40^\circ\text{C}$  to  $+125^\circ\text{C}$

## 2 Applications

- Shunt-resistor-based current sensing and isolated voltage measurement in:
  - [Industrial motor drives](#)
  - [Photovoltaic inverters](#)
  - [Uninterruptible and isolated power supplies](#)
  - [Power factor correction circuits](#)

## 3 Description

The AMC1303 (AMC1303x0510, AMC1303x0520, AMC1303x2510, and AMC1303x2520) is a family of precision, isolated delta-sigma ( $\Delta\Sigma$ ) modulators. The output is separated from the input circuitry by a capacitive isolation barrier that is highly resistant to magnetic interference. This barrier is certified to provide reinforced isolation of up to 7000V<sub>PK</sub> according to the DIN EN IEC 60747-17 (VDE 0884-17) and UL1577 standards, and supports a working voltage up to 1.5kV<sub>RMS</sub>.

The input of the AMC1303 device is optimized for direct connection to shunt resistors or other, low-impedance signal sources. The small size, high DC accuracy, low temperature drift, and high common-mode transient immunity (CMTI) support accurate isolated current sensing in noisy high-voltage applications.

The output bitstream of the AMC1303 is synchronized to the internally generated clock and is Manchester coded (AMC1303Ex) or uncoded (AMC1303Mx). Combined with a digital low-pass filter (such as a Sinc-filter) the device achieves 85dB of dynamic range at an effective output data rate of 78kSPS.

### Package Information

PART NUMBER	PACKAGE <sup>(1)</sup>	PACKAGE SIZE <sup>(2)</sup>
AMC1303x	DWV (SOIC, 8)	5.85mm × 11.5mm

(1) For more information, see the [Mechanical, Packaging, and Orderable Information](#).

(2) The package size (length × width) is a nominal value and includes pins, where applicable.

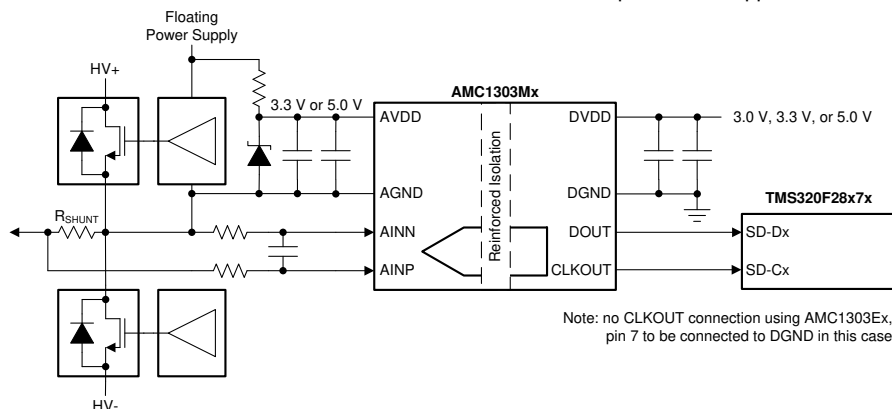

### Application Schematic



## Table of Contents

<b>1 Features</b> .....	1	7.1 Overview.....	20
<b>2 Applications</b> .....	1	7.2 Functional Block Diagram.....	20
<b>3 Description</b> .....	1	7.3 Feature Description.....	21
<b>4 Device Comparison Table</b> .....	3	7.4 Device Functional Modes.....	25
<b>5 Pin Configuration and Functions</b> .....	3	<b>8 Application and Implementation</b> .....	26
<b>6 Specifications</b> .....	4	8.1 Application Information.....	26
6.1 Absolute Maximum Ratings.....	4	8.2 Typical Applications.....	27
6.2 ESD Ratings.....	4	8.3 Power Supply Recommendations.....	32
6.3 Recommended Operating Conditions.....	4	8.4 Layout.....	33
6.4 Thermal Information.....	5	<b>9 Device and Documentation Support</b> .....	34
6.5 Power Ratings.....	5	9.1 Device Support.....	34
6.6 Insulation Specifications.....	6	9.2 Documentation Support.....	34
6.7 Safety-Related Certifications.....	7	9.3 Receiving Notification of Documentation Updates... 34	
6.8 Safety Limiting Values.....	7	9.4 Support Resources.....	34
6.9 Electrical Characteristics: AMC1303x05x.....	8	9.5 Trademarks.....	34
6.10 Electrical Characteristics: AMC1303x25x.....	10	9.6 Electrostatic Discharge Caution.....	34
6.11 Switching Characteristics.....	12	9.7 Glossary.....	34
6.12 Timing Diagrams.....	12	<b>10 Revision History</b> .....	34
6.13 Insulation Characteristics Curves.....	13	<b>11 Mechanical, Packaging, and Orderable Information</b> .....	35
6.14 Typical Characteristics.....	14		
<b>7 Detailed Description</b> .....	20		

## 4 Device Comparison Table

DEVICE	LINEAR INPUT VOLTAGE RANGE	DIFFERENTIAL INPUT RESISTANCE	DIGITAL OUTPUT INTERFACE	INTERNAL CLOCK FREQUENCY
AMC1303E0510	±50mV	4.9kΩ	Manchester-coded CMOS	10MHz
AMC1303E2510	±250mV	22kΩ	Manchester-coded CMOS	
AMC1303M0510	±50mV	4.9kΩ	Uncoded CMOS	
AMC1303M2510	±250mV	22kΩ	Uncoded CMOS	
AMC1303E0520	±50mV	4.9kΩ	Manchester-coded CMOS	20MHz
AMC1303E2520	±250mV	22kΩ	Manchester-coded CMOS	
AMC1303M0520	±50mV	4.9 kΩ	Uncoded CMOS	
AMC1303M2520	±250mV	22kΩ	Uncoded CMOS	
AMC1303M2520F <sup>(1)</sup>	±250mV	22kΩ	Uncoded CMOS	

(1) Optimised for lower radiated emission

## 5 Pin Configuration and Functions

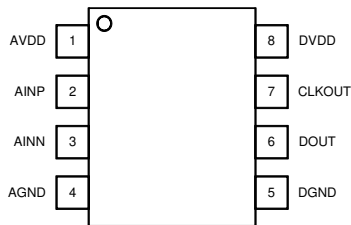

**Figure 5-1. AMC1303Mx: DWV Package, 8-Pin SOIC (Top View)**

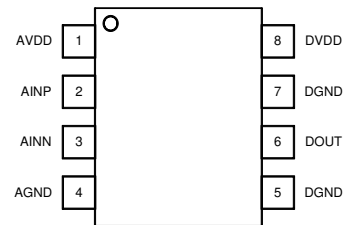

**Figure 5-2. AMC1303Ex: DWV Package, 8-Pin SOIC (Top View)**

**Table 5-1. Pin Functions**

NAME	PIN		TYPE	DESCRIPTION
	AMC1303Mx	AMC1303Ex		
AGND	4	4	—	Analog (high-side) ground reference.
AINN	3	3	I	Inverting analog input.
AINP	2	2	I	Noninverting analog input.
AVDD	1	1	—	Analog (high-side) power supply, 3.0V to 5.5V. See the <a href="#">Power Supply Recommendations</a> section for decoupling recommendations.
CLKOUT	7	—	O	Modulator clock output, 10MHz (on AMC1303Mxx10) or 20MHz (on AMC1303Mxx20) nominal.
DGND	5	5	—	Digital (controller-side) ground reference.
DGND	—	7	—	Connect this pin to the controller-side ground for AMC1303Ex derivatives.
DOUT	6	6	O	Modulator bitstream output. This pin is a Manchester coded output for the AMC1303Ex derivatives.
DVDD	8	8	—	Digital (controller-side) power supply, 2.7V to 5.5V. See the <a href="#">Power Supply Recommendations</a> section for decoupling recommendations.

## 6 Specifications

### 6.1 Absolute Maximum Ratings

see (1)

	MIN	MAX	UNIT
Supply voltage, AVDD to AGND or DVDD to DGND	-0.3	6.5	V
Analog input voltage at AINP, AINN	AGND - 6	AVDD + 0.5	V
Digital output voltage at DOUT, CLKOUT	DGND - 0.5	DVDD + 0.5	V
Input current to any pin except supply pins	-10	10	mA
Junction temperature, T <sub>J</sub>		150	°C
Storage temperature, T <sub>stg</sub>	-65	150	°C

- (1) Stresses beyond those listed under *Absolute Maximum Ratings* may cause permanent damage to the device. These are stress ratings only, which do not imply functional operation of the device at these or any other conditions beyond those indicated under *Recommended Operating Conditions*. Exposure to absolute-maximum-rated conditions for extended periods may affect device reliability.

### 6.2 ESD Ratings

			VALUE	UNIT
V <sub>(ESD)</sub>	Electrostatic discharge	Human-body model (HBM), per ANSI/ESDA/JEDEC JS-001 <sup>(1)</sup>	±2000	V
		Charged-device model (CDM), per JEDEC specification JESD22-C101 <sup>(2)</sup>	±1000	

- (1) JEDEC document JEP155 states that 500V HBM allows safe manufacturing with a standard ESD control process.  
 (2) JEDEC document JEP157 states that 250V CDM allows safe manufacturing with a standard ESD control process.

### 6.3 Recommended Operating Conditions

over operating ambient temperature range (unless otherwise noted)

		MIN	NOM	MAX	UNIT
AVDD	Analog (high-side) supply voltage (AVDD to AGND)	3.0	5.0	5.5	V
DVDD	Digital (controller-side) supply voltage (DVDD to DGND)	2.7	3.3	5.5	V
T <sub>A</sub>	Operating ambient temperature	-40		125	°C

## 6.4 Thermal Information

THERMAL METRIC <sup>(1)</sup>		AMC1303x	UNIT
		DWV (SOIC)	
		8 PINS	
R <sub>θJA</sub>	Junction-to-ambient thermal resistance	112.2	°C/W
R <sub>θJC(top)</sub>	Junction-to-case (top) thermal resistance	47.6	°C/W
R <sub>θJB</sub>	Junction-to-board thermal resistance	60.0	°C/W
ψ <sub>JT</sub>	Junction-to-top characterization parameter	23.1	°C/W
ψ <sub>JB</sub>	Junction-to-board characterization parameter	60.0	°C/W
R <sub>θJC(bot)</sub>	Junction-to-case (bottom) thermal resistance	N/A	°C/W

(1) For more information about traditional and new thermal metrics, see the [Semiconductor and IC Package Thermal Metrics application note](#).

## 6.5 Power Ratings

PARAMETER		TEST CONDITIONS	MIN	TYP	MAX	UNIT
P <sub>D</sub>	Maximum power dissipation (both sides)	AMC1303Exxx20, AVDD = DVDD = 5.5V			89.65	mW
		AMC1303Mxxx20, AVDD = DVDD = 5.5V			93.50	
P <sub>D1</sub>	Maximum power dissipation (high-side supply)	AMC1303xxx20, AVDD = 5.5V			53.90	mW
P <sub>D2</sub>	Maximum power dissipation (low-side supply)	AMC1303Exxx20, DVDD = 5.5V			35.75	mW
		AMC1303Mxxx20, DVDD = 5.5V			39.60	

## 6.6 Insulation Specifications

over operating ambient temperature range (unless otherwise noted)

PARAMETER		TEST CONDITIONS	VALUE	UNIT
<b>GENERAL</b>				
CLR	External clearance <sup>(1)</sup>	Shortest pin-to-pin distance through air	≥ 8.5	mm
CPG	External creepage <sup>(1)</sup>	Shortest pin-to-pin distance across the package surface	≥ 8.5	mm
DTI	Distance through insulation	Minimum internal gap (internal clearance) of the double insulation (2 × 0.0105mm)	≥ 0.021	mm
CTI	Comparative tracking index	DIN EN 60112 (VDE 0303-11); IEC 60112	≥ 600	V
	Material group	According to IEC 60664-1	I	
	Overvoltage category per IEC 60664-1	Rated mains voltage ≤ 300V <sub>RMS</sub>	I-IV	
		Rated mains voltage ≤ 600V <sub>RMS</sub>	I-IV	
		Rated mains voltage ≤ 1000V <sub>RMS</sub>	I-III	
<b>DIN EN IEC 60747-17 (VDE 0884-17)<sup>(2)</sup></b>				
V <sub>IORM</sub>	Maximum repetitive peak isolation voltage	At ac voltage (bipolar)	2121	V <sub>PK</sub>
V <sub>IOWM</sub>	Maximum-rated isolation working voltage	At ac voltage (sine wave)	1500	V <sub>RMS</sub>
		At dc voltage	2121	V <sub>DC</sub>
V <sub>IOTM</sub>	Maximum transient isolation voltage	V <sub>TEST</sub> = V <sub>IOTM</sub> , t = 60s (qualification test) V <sub>TEST</sub> = 1.2 × V <sub>IOTM</sub> , t = 1s (100% production test)	7000	V <sub>PK</sub>
V <sub>IMP</sub>	Maximum impulse voltage <sup>(3)</sup>	Tested in air, 1.2/50μs waveform per IEC 62368-1	9800	V <sub>PK</sub>
V <sub>IOSM</sub>	Maximum surge isolation voltage <sup>(4)</sup>	Tested in oil (qualification test), 1.2/50μs waveform per IEC 62368-1	12800	V <sub>PK</sub>
q <sub>pd</sub>	Apparent charge <sup>(5)</sup>	Method a, after input/output safety test subgroup 2 / 3, V <sub>ini</sub> = V <sub>IOTM</sub> , t <sub>ini</sub> = 60s, V <sub>pd(m)</sub> = 1.2 × V <sub>IORM</sub> = 2545V <sub>PK</sub> , t <sub>m</sub> = 10s	≤ 5	pC
		Method a, after environmental tests subgroup 1, V <sub>ini</sub> = V <sub>IOTM</sub> , t <sub>ini</sub> = 60s, V <sub>pd(m)</sub> = 1.6 × V <sub>IORM</sub> = 3394V <sub>PK</sub> , t <sub>m</sub> = 10s	≤ 5	
		Method b1, at routine test (100% production) and type test, V <sub>ini</sub> = V <sub>IOTM</sub> , t <sub>ini</sub> = 1s, V <sub>pd(m)</sub> = 1.875 × V <sub>IORM</sub> = 3977V <sub>PK</sub> , t <sub>m</sub> = 1s	≤ 5	
C <sub>IO</sub>	Barrier capacitance, input to output <sup>(6)</sup>	V <sub>IO</sub> = 0.5V <sub>PP</sub> at 1MHz	~1	pF
R <sub>IO</sub>	Insulation resistance, input to output <sup>(6)</sup>	V <sub>IO</sub> = 500V at T <sub>A</sub> = 25°C	> 10 <sup>12</sup>	Ω
		V <sub>IO</sub> = 500V at 100°C ≤ T <sub>A</sub> ≤ 125°C	> 10 <sup>11</sup>	Ω
		V <sub>IO</sub> = 500V at T <sub>S</sub> = 150°C	> 10 <sup>9</sup>	Ω
	Pollution degree		2	
	Climatic category		40/125/21	
<b>UL1577</b>				
V <sub>ISO</sub>	Withstand isolation voltage	V <sub>TEST</sub> = V <sub>ISO</sub> , t = 60s (qualification), V <sub>TEST</sub> = 1.2 × V <sub>ISO</sub> , t = 1s (100% production test)	5000	V <sub>RMS</sub>

- (1) Apply creepage and clearance requirements according to the specific equipment isolation standards of an application. Maintain the creepage and clearance distance of a board design and make sure the mounting pads of the isolator on the printed circuit board (PCB) do not reduce this distance. Creepage and clearance on a PCB become equal in certain cases. Techniques such as inserting grooves and ribs on the PCB help increase these specifications.
- (2) This coupler is suitable for *safe electrical insulation* only within the safety ratings. Compliance with the safety ratings is specified by means of suitable protective circuits.
- (3) Testing is carried out in air to determine the surge immunity of the package.
- (4) Testing is carried out in air or oil to determine the intrinsic surge immunity of the isolation barrier.
- (5) Apparent charge is electrical discharge caused by a partial discharge (pd).
- (6) All pins on each side of the barrier are tied together, creating a two-pin device.

## 6.7 Safety-Related Certifications

VDE	UL
DIN EN IEC 60747-17 (VDE 0884-17), EN IEC 60747-17, DIN EN IEC 62368-1 (VDE 0868-1), EN IEC 62368-1, IEC 62368-1 Clause : 5.4.3 ; 5.4.4.4 ; 5.4.9	Recognized under 1577 component recognition and CSA component acceptance NO 5 programs
Reinforced insulation	Single protection
Certificate number: 40040142	File number: E181974

## 6.8 Safety Limiting Values

Safety limiting intends to minimize potential damage to the isolation barrier upon failure of input or output circuitry.

PARAMETER		TEST CONDITIONS	MIN	TYP	MAX	UNIT
I <sub>S</sub>	Safety input, output, or supply current, see <a href="#">Figure 6-3</a>	R <sub>θJA</sub> = 112.2°C/W, VDD1 = VDD2 = 5.5 V, T <sub>J</sub> = 150°C, T <sub>A</sub> = 25°C			202.5	mA
		R <sub>θJA</sub> = 112.2°C/W, VDD1 = VDD2 = 3.6 V, T <sub>J</sub> = 150°C, T <sub>A</sub> = 25°C			309.4	
P <sub>S</sub>	Safety input, output, or total power, see <a href="#">Figure 6-4</a>	R <sub>θJA</sub> = 112.2°C/W, T <sub>J</sub> = 150°C, T <sub>A</sub> = 25°C			1114 <sup>(1)</sup>	mW
T <sub>S</sub>	Maximum safety temperature				150	°C

- (1) The maximum safety temperature, T<sub>S</sub>, has the same value as the maximum junction temperature, T<sub>J</sub>, specified for the device. The I<sub>S</sub> and P<sub>S</sub> parameters represent the safety current and safety power, respectively. Do not exceed the maximum limits of I<sub>S</sub> and P<sub>S</sub>. These limits vary with the ambient temperature, T<sub>A</sub>.

The junction-to-air thermal resistance, R<sub>θJA</sub>, in the [Thermal Information](#) table is that of a device installed on a high-K test board for leaded surface-mount packages. Use these equations to calculate the value for each parameter:

$T_J = T_A + R_{\theta JA} \times P$ , where P is the power dissipated in the device.

$T_{J(max)} = T_S = T_A + R_{\theta JA} \times P_S$ , where T<sub>J(max)</sub> is the maximum junction temperature.

$P_S = I_S \times AVDD_{max} + I_S \times AVDD_{max}$ , where AVDD<sub>max</sub> is the maximum high-side supply voltage and DVDD<sub>max</sub> is the maximum controller-side supply voltage.

## 6.9 Electrical Characteristics: AMC1303x05x

minimum and maximum specifications apply from  $T_A = -40^\circ\text{C}$  to  $+125^\circ\text{C}$ ,  $AVDD = 3.0\text{V}$  to  $5.5\text{V}$ ,  $DVDD = 2.7\text{V}$  to  $5.5\text{V}$ ,  $A_{INP} = -50\text{mV}$  to  $50\text{mV}$ ,  $A_{INN} = \text{AGND}$ , and sinc<sup>3</sup> filter with  $\text{OSR} = 256$  (unless otherwise noted); typical specifications are at  $T_A = 25^\circ\text{C}$ ,  $AVDD = 5\text{V}$ , and  $DVDD = 3.3\text{V}$

PARAMETER		TEST CONDITIONS	MIN	TYP	MAX	UNIT
<b>ANALOG INPUTS</b>						
$V_{\text{Clipping}}$	Differential input voltage before clipping output	$V_{\text{IN}} = A_{\text{INP}} - A_{\text{INN}}$		$\pm 64$		mV
FSR	Specified linear differential full-scale	$V_{\text{IN}} = A_{\text{INP}} - A_{\text{INN}}$	-50		50	mV
	Absolute common-mode input voltage <sup>(1)</sup>	$(A_{\text{INP}} + A_{\text{INN}}) / 2$ to AGND	-2		AVDD	V
$V_{\text{CM}}$	Operating common-mode input voltage	$(A_{\text{INP}} + A_{\text{INN}}) / 2$ to AGND	-0.032		AVDD - 2.1	V
$V_{\text{CMov}}$	Common-mode overvoltage detection level	$(A_{\text{INP}} + A_{\text{INN}}) / 2$ to AGND	AVDD - 2			V
	Hysteresis of the common-mode overvoltage detection level			90		mV
$C_{\text{IN}}$	Single-ended input capacitance	$A_{\text{INN}} = \text{AGND}$		4		pF
$C_{\text{IND}}$	Differential input capacitance			2		pF
$R_{\text{IN}}$	Single-ended input resistance	$A_{\text{INN}} = \text{AGND}$		4.75		k $\Omega$
$R_{\text{IND}}$	Differential input resistance			4.9		k $\Omega$
$I_{\text{IB}}$	Input bias current	$A_{\text{INP}} = A_{\text{INN}} = \text{AGND}$ , $I_{\text{IB}} = I_{\text{IBP}} + I_{\text{IBN}}$	-97	-72	-57	$\mu\text{A}$
$I_{\text{IO}}$	Input offset current			$\pm 10$		nA
CMTI	Common-mode transient immunity		50	100		kV/ $\mu\text{s}$
CMRR	Common-mode rejection ratio	$A_{\text{INP}} = A_{\text{INN}}$ , $f_{\text{IN}} = 0\text{Hz}$ , $V_{\text{CM min}} \leq V_{\text{IN}} \leq V_{\text{CM max}}$		-99		dB
		$A_{\text{INP}} = A_{\text{INN}}$ , $f_{\text{IN}}$ from 0.1Hz to 50kHz, $V_{\text{CM min}} \leq V_{\text{IN}} \leq V_{\text{CM max}}$		-98		
PSRR	Power-supply rejection ratio	$A_{\text{INP}} = A_{\text{INN}} = \text{AGND}$ , $3.0\text{V} \leq AVDD \leq 5.5\text{V}$ , at dc		-108		dB
		$A_{\text{INP}} = A_{\text{INN}} = \text{AGND}$ , $3.0\text{V} \leq AVDD \leq 5.5\text{V}$ , 10kHz, 100mV ripple		-107		
BW	Input bandwidth <sup>(2)</sup>	AMC1303x0510		430		kHz
		AMC1303x0520		800		
<b>DC ACCURACY</b>						
DNL	Differential nonlinearity	Resolution: 16 bits	-0.99		0.99	LSB
INL	Integral nonlinearity <sup>(3)</sup>	Resolution: 16 bits	-4	$\pm 1$	4	LSB
$E_{\text{O}}$	Offset error	Initial, at $T_A = 25^\circ\text{C}$ , $A_{\text{INP}} = A_{\text{INN}} = \text{AGND}$	-50	$\pm 2.5$	50	$\mu\text{V}$
$TCE_{\text{O}}$	Offset error thermal drift <sup>(4)</sup>		-1	$\pm 0.25$	1	$\mu\text{V}/^\circ\text{C}$
$E_{\text{G}}$	Gain error	Initial, at $T_A = 25^\circ\text{C}$	-0.2%	$\pm 0.005\%$	0.2%	
$TCE_{\text{G}}$	Gain error thermal drift <sup>(5)</sup>		-40	$\pm 20$	40	ppm/ $^\circ\text{C}$
<b>AC ACCURACY</b>						
SNR	Signal-to-noise ratio	AMC1303x0510, $f_{\text{IN}} = 35\text{Hz}$	81	84		dB
		AMC1303x0520, $f_{\text{IN}} = 35\text{Hz}$	79	83		
THD	Total harmonic distortion	$f_{\text{IN}} = 35\text{Hz}$		-97	-86	dB
SFDR	Spurious-free dynamic range	AMC1303x0510, $f_{\text{IN}} = 35\text{Hz}$		96		dB
		AMC1303x0520, $f_{\text{IN}} = 35\text{Hz}$		97		



## 6.9 Electrical Characteristics: AMC1303x05x (continued)

minimum and maximum specifications apply from  $T_A = -40^\circ\text{C}$  to  $+125^\circ\text{C}$ ,  $AVDD = 3.0\text{V}$  to  $5.5\text{V}$ ,  $DVDD = 2.7\text{V}$  to  $5.5\text{V}$ ,  $A_{INP} = -50\text{mV}$  to  $50\text{mV}$ ,  $A_{INN} = \text{AGND}$ , and sinc<sup>3</sup> filter with OSR = 256 (unless otherwise noted); typical specifications are at  $T_A = 25^\circ\text{C}$ ,  $AVDD = 5\text{V}$ , and  $DVDD = 3.3\text{V}$

PARAMETER		TEST CONDITIONS	MIN	TYP	MAX	UNIT
<b>DIGITAL OUTPUTS (CMOS Logic)</b>						
$C_{LOAD}$	Output load capacitance			30		pF
$V_{OH}$	High-level output voltage	$I_{OH} = -20\mu\text{A}$	DVDD – 0.1			V
		$I_{OH} = -4\text{mA}$	DVDD – 0.4			
$V_{OL}$	Low-level output voltage	$I_{OL} = 20\mu\text{A}$			0.1	V
		$I_{OL} = 4\text{mA}$			0.4	
<b>POWER SUPPLY</b>						
$I_{AVDD}$	High-side supply current	AMC1303x0510, $3.0\text{V} \leq AVDD \leq 3.6\text{V}$		5.4	7.3	mA
		AMC1303x0510, $4.5\text{V} \leq AVDD \leq 5.5\text{V}$		6.0	8.0	
		AMC1303x0520, $3.0\text{V} \leq AVDD \leq 3.6\text{V}$		6.3	8.5	
		AMC1303x0520, $4.5\text{V} \leq AVDD \leq 5.5\text{V}$		7.2	9.8	
$I_{DVDD}$	Controller-side supply current	AMC1303E0510, $2.7\text{V} \leq DVDD \leq 3.6\text{V}$ , $C_{LOAD} = 15\text{pF}$		3.3	4.5	mA
		AMC1303E0510, $4.5\text{V} \leq DVDD \leq 5.5\text{V}$ , $C_{LOAD} = 15\text{pF}$		3.6	5.0	
		AMC1303M0510, $2.7\text{V} \leq DVDD \leq 3.6\text{V}$ , $C_{LOAD} = 15\text{pF}$		3.5	4.7	
		AMC1303M0510, $4.5\text{V} \leq DVDD \leq 5.5\text{V}$ , $C_{LOAD} = 15\text{pF}$		3.9	5.4	
		AMC1303E0520, $2.7\text{V} \leq DVDD \leq 3.6\text{V}$ , $C_{LOAD} = 15\text{pF}$		4.1	5.5	
		AMC1303E0520, $4.5\text{V} \leq DVDD \leq 5.5\text{V}$ , $C_{LOAD} = 15\text{pF}$		4.7	6.5	
		AMC1303M0520, $2.7\text{V} \leq DVDD \leq 3.6\text{V}$ , $C_{LOAD} = 15\text{pF}$		4.6	6.0	
		AMC1303M0520, $4.5\text{V} \leq DVDD \leq 5.5\text{V}$ , $C_{LOAD} = 15\text{pF}$		5.4	7.2	

- Steady-state voltage supported by the device in case of a system failure. See the specified common-mode input voltage  $V_{CM}$  for normal operation. Observe analog input voltage range as specified in the [Absolute Maximum Ratings](#) table.
- This parameter is the –3dB, second-order, roll-off frequency of the integrated differential input amplifier to consider for antialiasing filter designs.
- Integral nonlinearity is defined as the maximum deviation from a straight line passing through the end-points of the ideal ADC transfer function expressed as number of LSBs or as a percent of the specified linear full-scale range FSR.

- Offset error drift is calculated using the box method as described by the following equation:

$$TCE_o = \frac{value_{MAX} - value_{MIN}}{TempRange}$$

- Gain error drift is calculated using the box method as described by the following equation:

$$TCE_g (ppm) = \left( \frac{value_{MAX} - value_{MIN}}{value \times TempRange} \right) \times 10^6$$

## 6.10 Electrical Characteristics: AMC1303x25x

minimum and maximum specifications apply from  $T_A = -40^\circ\text{C}$  to  $+125^\circ\text{C}$ ,  $AVDD = 3.0\text{V}$  to  $5.5\text{V}$ ,  $DVDD = 2.7\text{V}$  to  $5.5\text{V}$ ,  $A_{INP} = -250\text{mV}$  to  $250\text{mV}$ ,  $A_{INN} = \text{AGND}$ , and sinc<sup>3</sup> filter with  $\text{OSR} = 256$  (unless otherwise noted); typical specifications are at  $T_A = 25^\circ\text{C}$ ,  $AVDD = 5\text{V}$ , and  $DVDD = 3.3\text{V}$

PARAMETER		TEST CONDITIONS	MIN	TYP	MAX	UNIT
<b>ANALOG INPUTS</b>						
$V_{\text{Clipping}}$	Differential input voltage before clipping output	$V_{\text{IN}} = A_{\text{INP}} - A_{\text{INN}}$		±320		mV
FSR	Specified linear differential full-scale	$V_{\text{IN}} = A_{\text{INP}} - A_{\text{INN}}$	-250		250	mV
	Absolute common-mode input voltage <sup>(1)</sup>	$(A_{\text{INP}} + A_{\text{INN}}) / 2$ to AGND	-2		AVDD	V
$V_{\text{CM}}$	Operating common-mode input voltage	$(A_{\text{INP}} + A_{\text{INN}}) / 2$ to AGND	-0.16		AVDD - 2.1	V
$V_{\text{CMov}}$	Common-mode overvoltage detection level	$(A_{\text{INP}} + A_{\text{INN}}) / 2$ to AGND	AVDD - 2			V
	Hysteresis of common-mode overvoltage detection level			90		mV
$C_{\text{IN}}$	Single-ended input capacitance	$A_{\text{INN}} = \text{AGND}$		2		pF
$C_{\text{IND}}$	Differential input capacitance			1		pF
$R_{\text{IN}}$	Single-ended input resistance	$A_{\text{INN}} = \text{AGND}$		19		kΩ
$R_{\text{IND}}$	Differential input resistance			22		kΩ
$I_{\text{IB}}$	Input bias current	$A_{\text{INP}} = A_{\text{INN}} = \text{AGND}$ , $I_{\text{IB}} = I_{\text{IBP}} + I_{\text{IBN}}$	-82	-60	-48	μA
$I_{\text{IO}}$	Input offset current			±5		nA
CMTI	Common-mode transient immunity		50	100		kV/μs
CMRR	Common-mode rejection ratio	$A_{\text{INP}} = A_{\text{INN}}$ , $f_{\text{IN}} = 0\text{Hz}$ , $V_{\text{CM min}} \leq V_{\text{IN}} \leq V_{\text{CM max}}$		-98		dB
		$A_{\text{INP}} = A_{\text{INN}}$ , $f_{\text{IN}}$ from 0.1Hz to 50kHz, $V_{\text{CM min}} \leq V_{\text{IN}} \leq V_{\text{CM max}}$		-98		
PSRR	Power-supply rejection ratio	$A_{\text{INP}} = A_{\text{INN}} = \text{AGND}$ , $3.0\text{V} \leq AVDD \leq 5.5\text{V}$ , at dc		-97		dB
		$A_{\text{INP}} = A_{\text{INN}} = \text{AGND}$ , $3.0\text{V} \leq AVDD \leq 5.5\text{V}$ , 10kHz, 100mV ripple		-94.5		
BW	Input bandwidth <sup>(2)</sup>	AMC1303x2510		510		kHz
		AMC1303x2520		900		
<b>DC ACCURACY</b>						
DNL	Differential nonlinearity	Resolution: 16 bits	-0.99		0.99	LSB
INL	Integral nonlinearity <sup>(3)</sup>	Resolution: 16 bits	-4	±1	4	LSB
$E_{\text{O}}$	Offset error	Initial, at $T_A = 25^\circ\text{C}$ , $A_{\text{INP}} = A_{\text{INN}} = \text{AGND}$	-100	±4.5	100	μV
$TCE_{\text{O}}$	Offset error thermal drift <sup>(4)</sup>		-1	±0.15	1	μV/°C
$E_{\text{G}}$	Gain error	Initial, at $T_A = 25^\circ\text{C}$	-0.2%	-0.005%	0.2%	
$TCE_{\text{G}}$	Gain error thermal drift <sup>(5)</sup>		-40	±20	40	ppm/°C
<b>AC ACCURACY</b>						
SNR	Signal-to-noise ratio	AMC1303x2510, $f_{\text{IN}} = 35\text{Hz}$	85	87		dB
		AMC1303x2520, $f_{\text{IN}} = 35\text{Hz}$	84.5	86.5		
THD	Total harmonic distortion	AMC1303x2510, $f_{\text{IN}} = 35\text{Hz}$		-97	-86	dB
		AMC1303x2520, $f_{\text{IN}} = 35\text{Hz}$		-101	-86	
SFDR	Spurious-free dynamic range	$f_{\text{IN}} = 35\text{Hz}$		98		dB

## 6.10 Electrical Characteristics: AMC1303x25x (continued)

minimum and maximum specifications apply from  $T_A = -40^\circ\text{C}$  to  $+125^\circ\text{C}$ ,  $AVDD = 3.0\text{V}$  to  $5.5\text{V}$ ,  $DVDD = 2.7\text{V}$  to  $5.5\text{V}$ ,  $A_{INP} = -250\text{mV}$  to  $250\text{mV}$ ,  $A_{INN} = \text{AGND}$ , and sinc<sup>3</sup> filter with  $\text{OSR} = 256$  (unless otherwise noted); typical specifications are at  $T_A = 25^\circ\text{C}$ ,  $AVDD = 5\text{V}$ , and  $DVDD = 3.3\text{V}$

PARAMETER		TEST CONDITIONS	MIN	TYP	MAX	UNIT
<b>DIGITAL OUTPUTS (CMOS LOGIC)</b>						
$C_{\text{LOAD}}$	Output load capacitance			30		pF
$V_{\text{OH}}$	High-level output voltage	$I_{\text{OH}} = -20\mu\text{A}$	DVDD – 0.1			V
		$I_{\text{OH}} = -4\text{mA}$	DVDD – 0.4			
$V_{\text{OL}}$	Low-level output voltage	$I_{\text{OL}} = 20\mu\text{A}$			0.1	V
		$I_{\text{OL}} = 4\text{mA}$			0.4	
<b>POWER SUPPLY</b>						
$I_{\text{AVDD}}$	High-side supply current	AMC1303x2510, $3.0\text{V} \leq AVDD \leq 3.6\text{V}$		5.4	7.3	mA
		AMC1303x2510, $4.5\text{V} \leq AVDD \leq 5.5\text{V}$		6.0	8.0	
		AMC1303x2520, $3.0\text{V} \leq AVDD \leq 3.6\text{V}$		6.3	8.5	
		AMC1303x2520, $4.5\text{V} \leq AVDD \leq 5.5\text{V}$		7.2	9.8	
$I_{\text{DVDD}}$	Controller-side supply current	AMC1303E2510, $2.7\text{V} \leq DVDD \leq 3.6\text{V}$ , $C_{\text{LOAD}} = 15\text{pF}$		3.3	4.5	mA
		AMC1303E2510, $4.5\text{V} \leq DVDD \leq 5.5\text{V}$ , $C_{\text{LOAD}} = 15\text{pF}$		3.6	5.0	
		AMC1303M2510, $2.7\text{V} \leq DVDD \leq 3.6\text{V}$ , $C_{\text{LOAD}} = 15\text{pF}$		3.5	4.7	
		AMC1303M2510, $4.5\text{V} \leq DVDD \leq 5.5\text{V}$ , $C_{\text{LOAD}} = 15\text{pF}$		3.9	5.4	
		AMC1303E2520, $2.7\text{V} \leq DVDD \leq 3.6\text{V}$ , $C_{\text{LOAD}} = 15\text{pF}$		4.1	5.5	
		AMC1303E2520, $4.5\text{V} \leq DVDD \leq 5.5\text{V}$ , $C_{\text{LOAD}} = 15\text{pF}$		4.7	6.5	
		AMC1303M2520, $2.7\text{V} \leq DVDD \leq 3.6\text{V}$ , $C_{\text{LOAD}} = 15\text{pF}$		4.6	6.0	
		AMC1303M2520, $4.5\text{V} \leq DVDD \leq 5.5\text{V}$ , $C_{\text{LOAD}} = 15\text{pF}$		5.4	7.2	

- Steady-state voltage supported by the device in case of a system failure. See the specified common-mode input voltage  $V_{\text{CM}}$  for normal operation. Observe analog input voltage range as specified in the [Absolute Maximum Ratings](#) table.
- This parameter is the –3dB, second-order, roll-off frequency of the integrated differential input amplifier to consider for antialiasing filter designs.
- Integral nonlinearity is defined as the maximum deviation from a straight line passing through the end-points of the ideal ADC transfer function expressed as number of LSBs or as a percent of the specified linear full-scale range FSR.

- Offset error drift is calculated using the box method as described by the following equation:

$$TCE_o = \frac{\text{value}_{\text{MAX}} - \text{value}_{\text{MIN}}}{\text{TempRange}}$$

- Gain error drift is calculated using the box method as described by the following equation:

$$TCE_g(\text{ppm}) = \left( \frac{\text{value}_{\text{MAX}} - \text{value}_{\text{MIN}}}{\text{value} \times \text{TempRange}} \right) \times 10^6$$

## 6.11 Switching Characteristics

over operating ambient temperature range (unless otherwise noted)

PARAMETER		TEST CONDITIONS	MIN	TYP	MAX	UNIT
f <sub>CLK</sub>	Internal clock frequency, on the CLKOUT pin of the AMC1303Mx only	AMC1303Mxx10	9.6	10	10.4	MHz
		AMC1303Mxx20	19.2	20	20.8	
	Internal clock duty cycle <sup>(1)</sup> , on the CLKOUT pin of the AMC1303Mx only		45%	50%	55%	
t <sub>h</sub>	DOUT hold time after rising edge of CLKOUT	AMC1303Mx, C <sub>LOAD</sub> = 15pF	7			ns
t <sub>d</sub>	DOUT delay time after rising edge of CLKOUT	AMC1303Mx, C <sub>LOAD</sub> = 15pF			15	ns
t <sub>r</sub>	DOUT, CLKOUT rise time	10% to 90%, 2.7V ≤ DVDD ≤ 3.6V, C <sub>LOAD</sub> = 15pF		0.8	3.5	ns
		10% to 90%, 4.5V ≤ DVDD ≤ 5.5 V, C <sub>LOAD</sub> = 15pF		1.8	3.9	
t <sub>f</sub>	DOUT, CLKOUT fall time	90% to 10%, 2.7V ≤ DVDD ≤ 3.6V, C <sub>LOAD</sub> = 15pF		0.8	3.5	ns
		90% to 10%, 4.5V ≤ DVDD ≤ 5.5V, C <sub>LOAD</sub> = 15pF		1.8	3.9	
t <sub>ASTART</sub>	Analog start-up time	AVDD step to 3.0V with DVDD ≥ 2.7V		0.5		ms

(1) Duty cycle values are specified by design.

## 6.12 Timing Diagrams

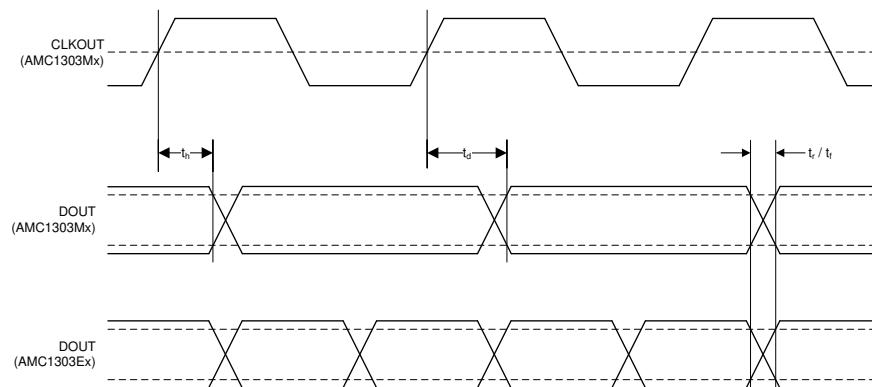

Figure 6-1. AMC1303Mx Digital Interface Timing

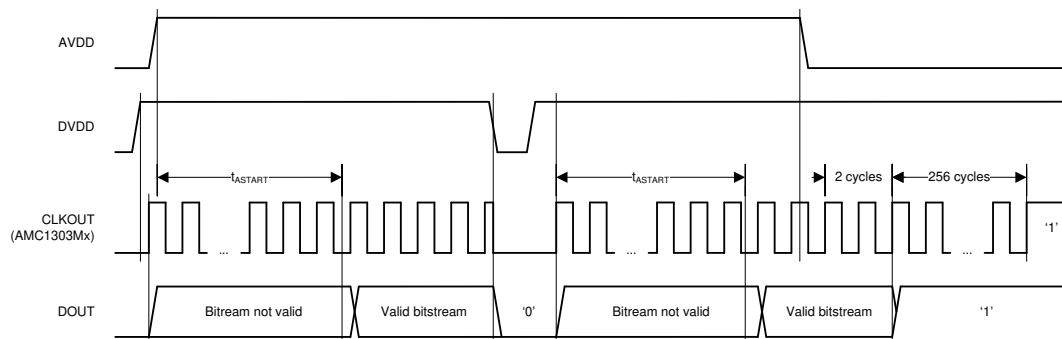

Figure 6-2. Digital Interface Start-Up Timing

### 6.13 Insulation Characteristics Curves

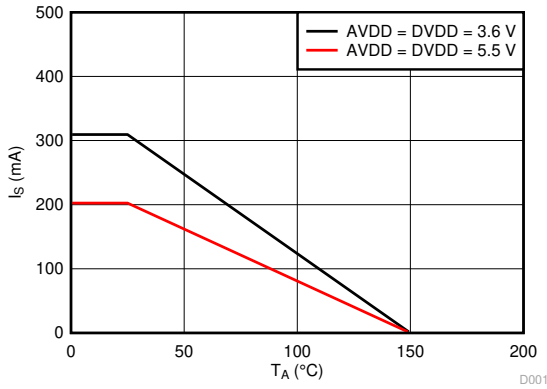

Figure 6-3. Thermal Derating Curve for Safety-Limiting Current per VDE

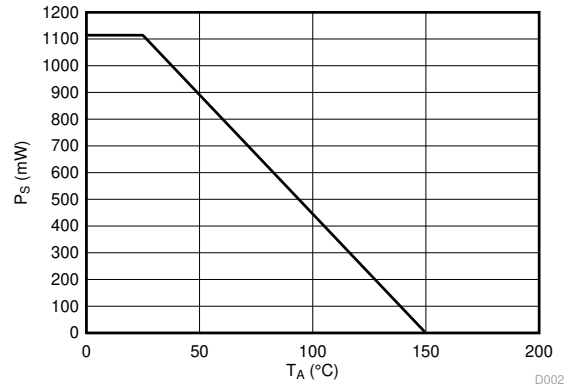
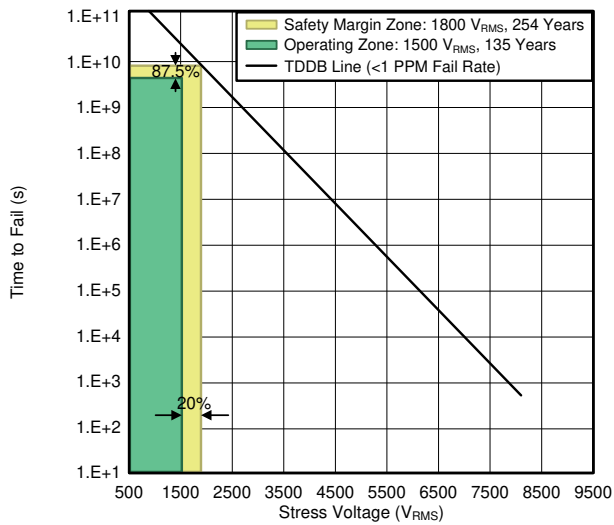

Figure 6-4. Thermal Derating Curve for Safety-Limiting Power per VDE



$T_A$  up to 150°C, stress-voltage frequency = 60Hz, isolation working voltage = 1500V<sub>RMS</sub>, operating lifetime = 135 years

Figure 6-5. Reinforced Isolation Capacitor Lifetime Projection

## 6.14 Typical Characteristics

at  $T_A = 25^\circ\text{C}$ ,  $AV_{DD} = 5\text{V}$ ,  $DV_{DD} = 3.3\text{V}$ ,  $A_{INP} = -50\text{mV}$  to  $50\text{mV}$  (AMC1303x05x) or  $-250\text{mV}$  to  $250\text{mV}$  (AMC1303x25x),  $A_{INN} = \text{AGND}$ , and sinc<sup>3</sup> filter with OSR = 256 (unless otherwise noted)

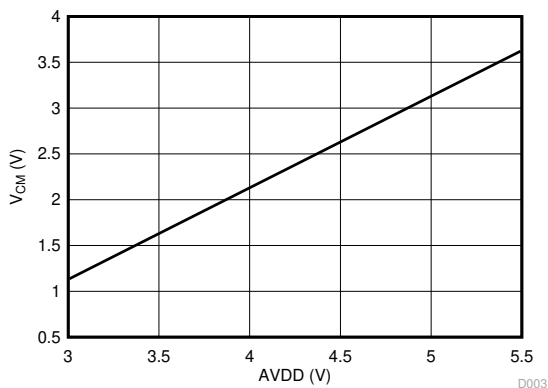

**Figure 6-6. Maximum Operating Common-Mode Input Voltage vs High-Side Supply Voltage**

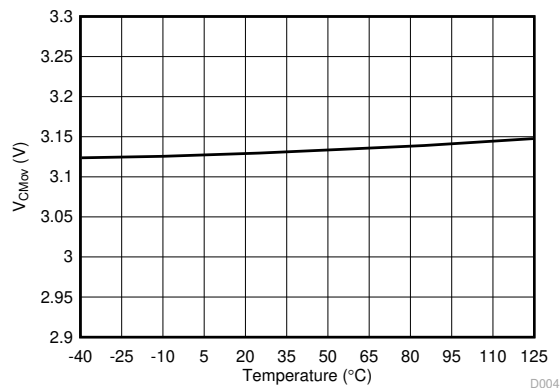

**Figure 6-7. Common-Mode Overvoltage Detection Level vs Temperature**

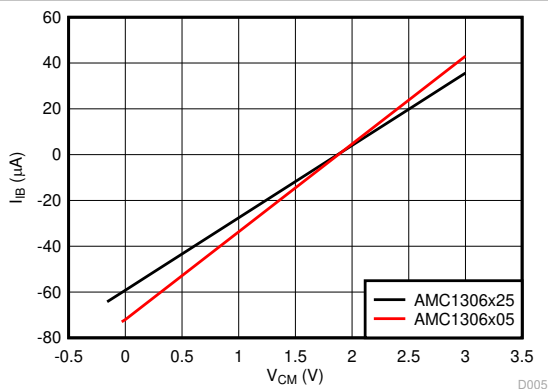

**Figure 6-8. Input Bias Current vs Common-Mode Input Voltage**

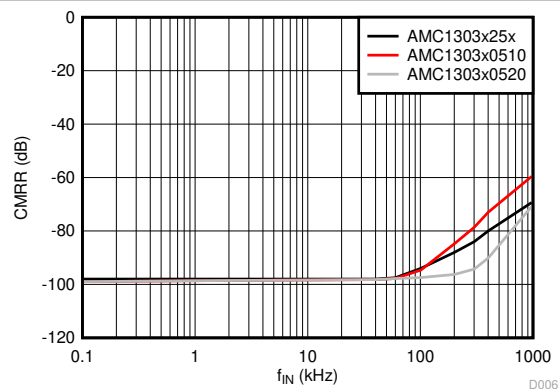

**Figure 6-9. Common-Mode Rejection Ratio vs Input Signal Frequency**

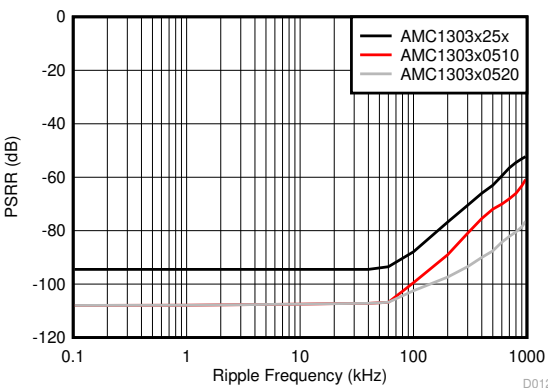

**Figure 6-10. Power-Supply Rejection Ratio vs Ripple Frequency**

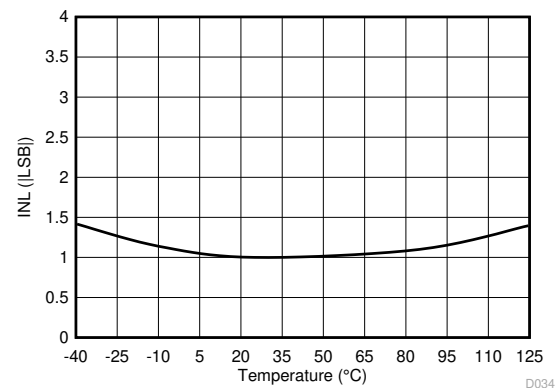

**Figure 6-11. Integral Nonlinearity vs Temperature**

### 6.14 Typical Characteristics (continued)

at  $T_A = 25^\circ\text{C}$ ,  $AVDD = 5\text{V}$ ,  $DVDD = 3.3\text{V}$ ,  $AINP = -50\text{mV}$  to  $50\text{mV}$  (AMC1303x05x) or  $-250\text{mV}$  to  $250\text{mV}$  (AMC1303x25x),  $AINN = AGND$ , and sinc<sup>3</sup> filter with  $OSR = 256$  (unless otherwise noted)

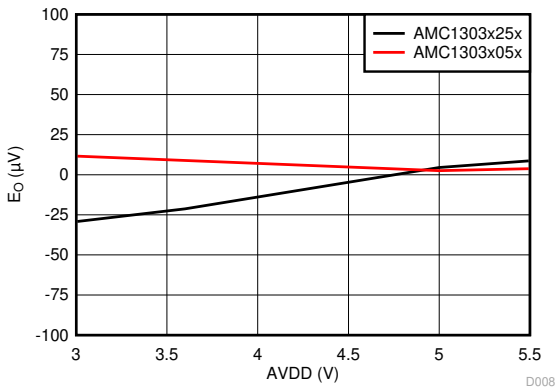

**Figure 6-12. Offset Error vs High-Side Supply Voltage**

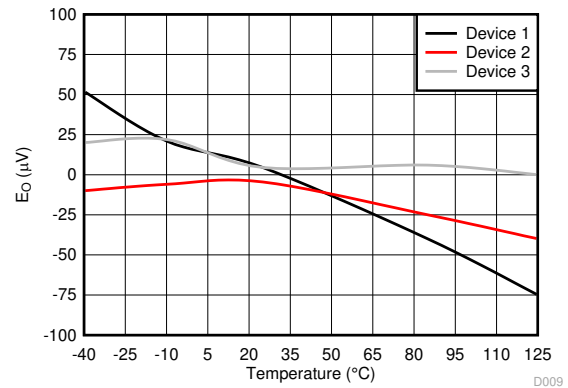

**Figure 6-13. Offset Error vs Temperature**

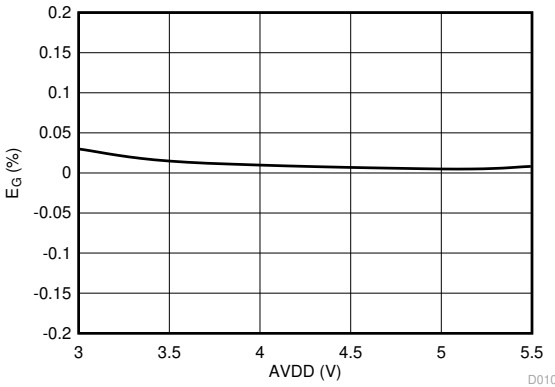

**Figure 6-14. Gain Error vs High-Side Supply Voltage**

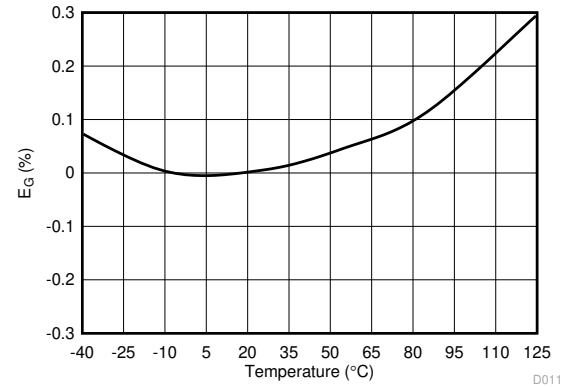

**Figure 6-15. Gain Error vs Temperature**

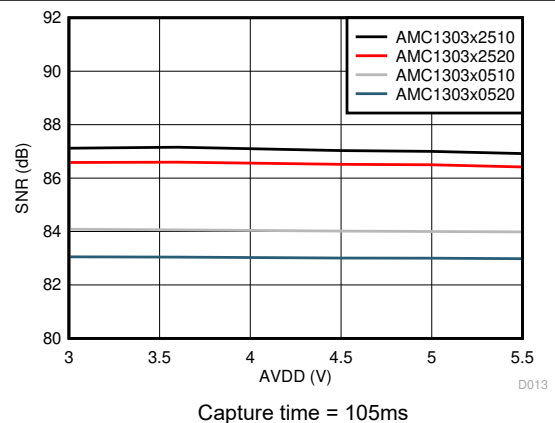

**Figure 6-16. Signal-to-Noise Ratio vs High-Side Supply Voltage**

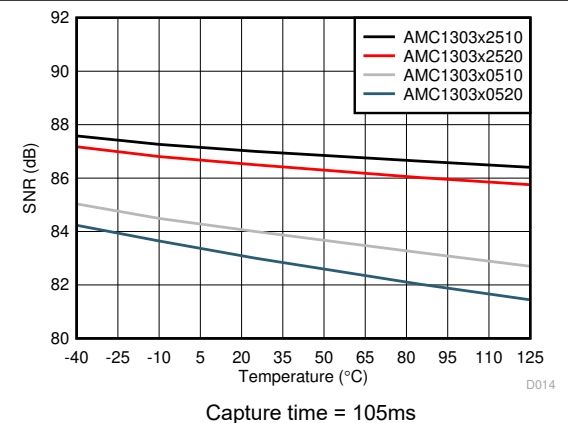

**Figure 6-17. Signal-to-Noise Ratio vs Temperature**

## 6.14 Typical Characteristics (continued)

at  $T_A = 25^\circ\text{C}$ ,  $AV_{DD} = 5\text{V}$ ,  $DV_{DD} = 3.3\text{V}$ ,  $A_{INP} = -50\text{mV}$  to  $50\text{mV}$  (AMC1303x05x) or  $-250\text{mV}$  to  $250\text{mV}$  (AMC1303x25x),  $A_{INN} = \text{AGND}$ , and sinc<sup>3</sup> filter with OSR = 256 (unless otherwise noted)

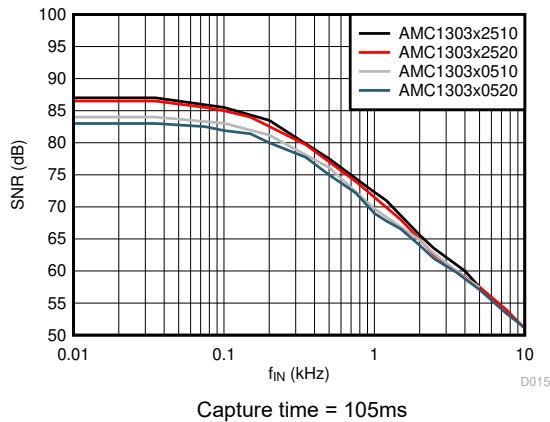

**Figure 6-18. Signal-to-Noise Ratio vs Input Signal Frequency**

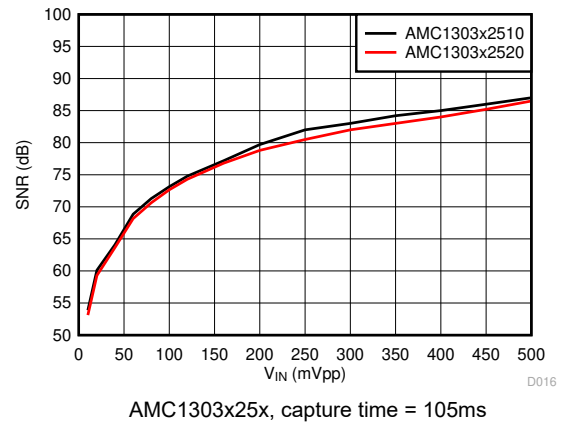

**Figure 6-19. Signal-to-Noise Ratio vs Input Signal Amplitude**

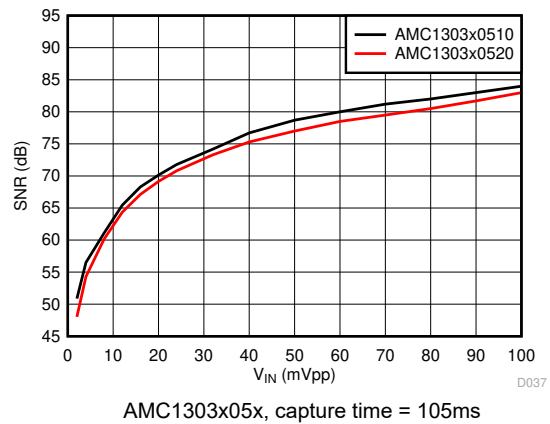

**Figure 6-20. Signal-to-Noise Ratio vs Input Signal Amplitude**

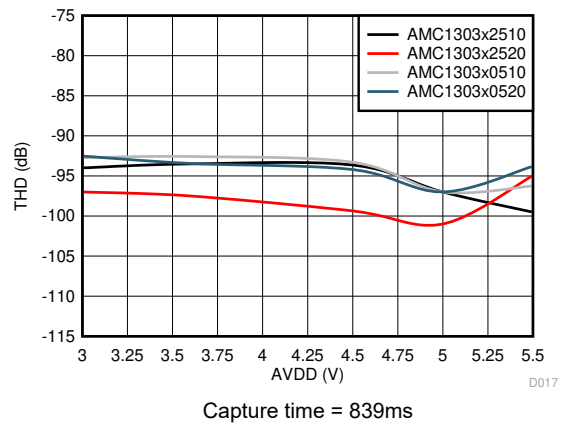

**Figure 6-21. Total Harmonic Distortion vs High-Side Supply Voltage**

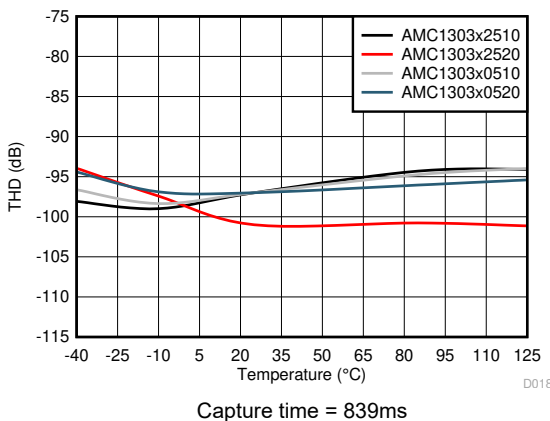

**Figure 6-22. Total Harmonic Distortion vs Temperature**

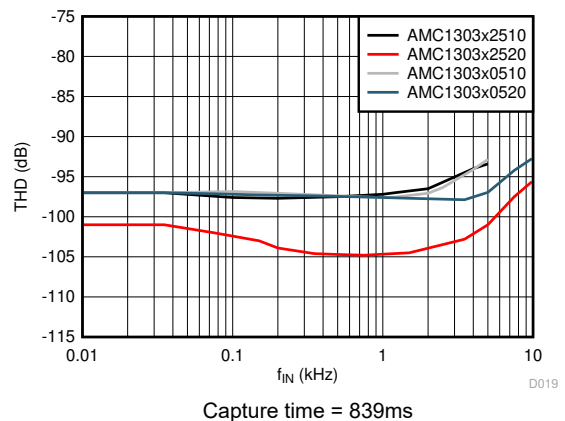
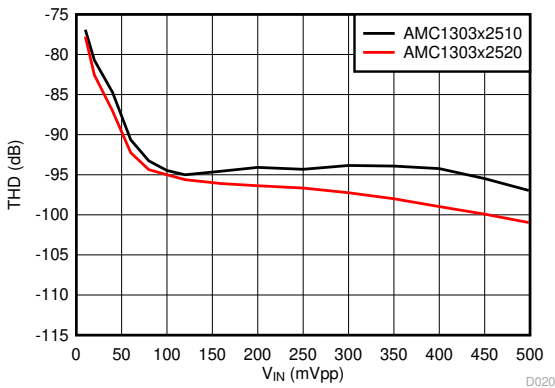

**Figure 6-23. Total Harmonic Distortion vs Input Signal Frequency**



### 6.14 Typical Characteristics (continued)

at  $T_A = 25^\circ\text{C}$ ,  $AV_{DD} = 5\text{V}$ ,  $DV_{DD} = 3.3\text{V}$ ,  $A_{INP} = -50\text{mV}$  to  $50\text{mV}$  (AMC1303x05x) or  $-250\text{mV}$  to  $250\text{mV}$  (AMC1303x25x),  $A_{INN} = \text{AGND}$ , and sinc<sup>3</sup> filter with OSR = 256 (unless otherwise noted)



AMC1303x25x, capture time = 839ms  
**Figure 6-24. Total Harmonic Distortion vs Input Signal Amplitude**

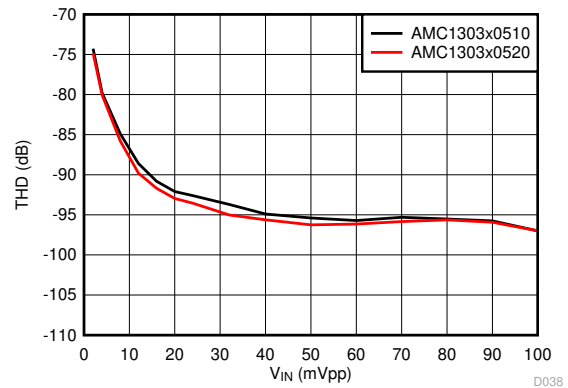

AMC1303x05x, capture time = 839ms  
**Figure 6-25. Total Harmonic Distortion vs Input Signal Amplitude**

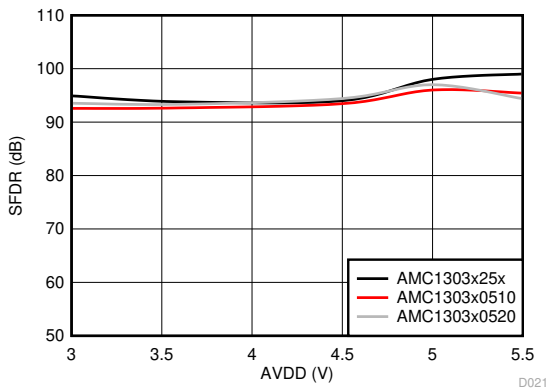

Capture time = 105ms  
**Figure 6-26. Spurious-Free Dynamic Range vs High-Side Supply Voltage**

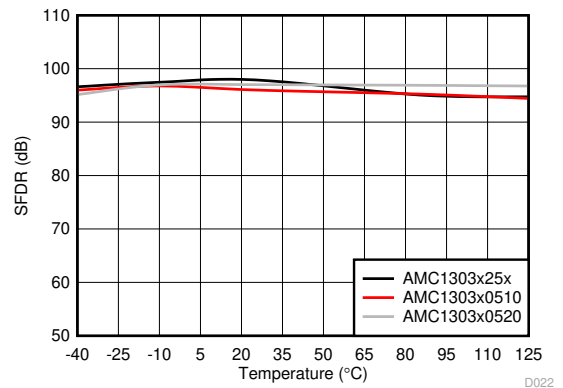

Capture time = 105ms  
**Figure 6-27. Spurious-Free Dynamic Range vs Temperature**

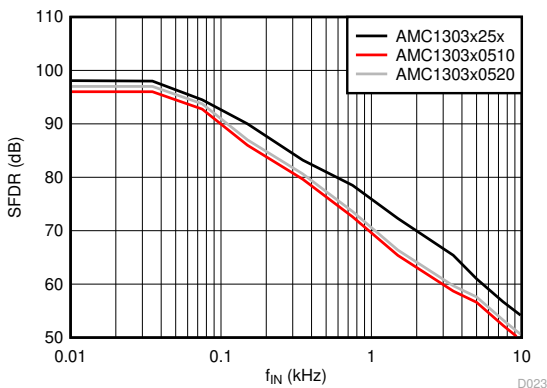

Capture time = 105ms  
**Figure 6-28. Spurious-Free Dynamic Range vs Input Signal Frequency**

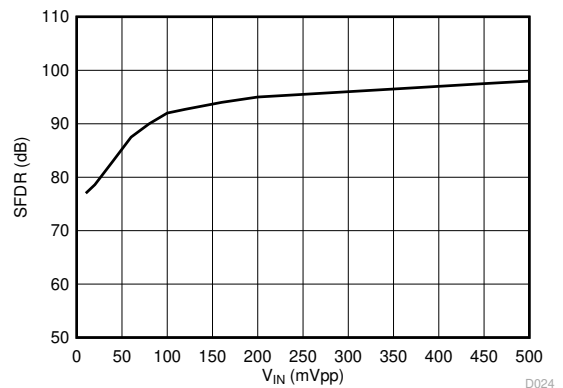

AMC1303x25x, capture time = 105ms  
**Figure 6-29. Spurious-Free Dynamic Range vs Input Signal Amplitude**

## 6.14 Typical Characteristics (continued)

at  $T_A = 25^\circ\text{C}$ ,  $AV_{DD} = 5\text{V}$ ,  $DV_{DD} = 3.3\text{V}$ ,  $A_{INP} = -50\text{mV}$  to  $50\text{mV}$  (AMC1303x05x) or  $-250\text{mV}$  to  $250\text{mV}$  (AMC1303x25x),  $A_{INN} = \text{AGND}$ , and sinc<sup>3</sup> filter with OSR = 256 (unless otherwise noted)

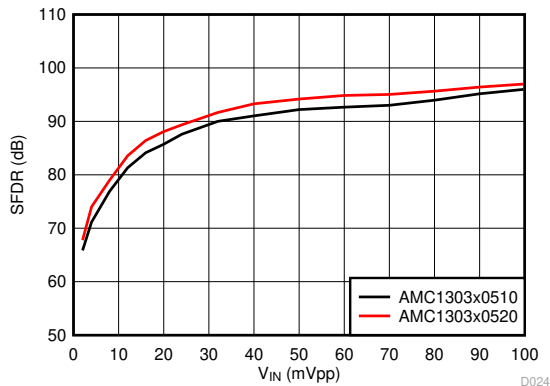

AMC1303x05x, capture time = 105ms

**Figure 6-30. Spurious-Free Dynamic Range vs Input Signal Amplitude**

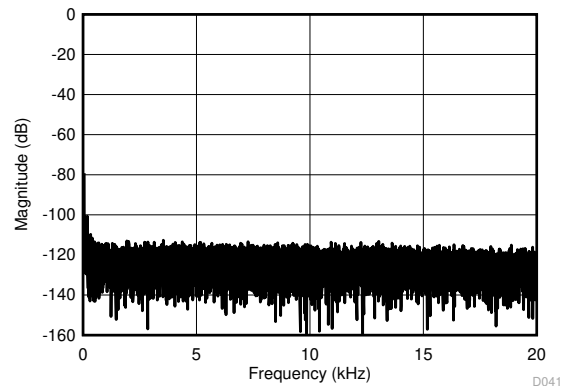

AMC1303x0510, capture time = 839ms,  $V_{IN} = 100\text{mV}_{PP}$

**Figure 6-31. Frequency Spectrum With 35Hz Input Signal**

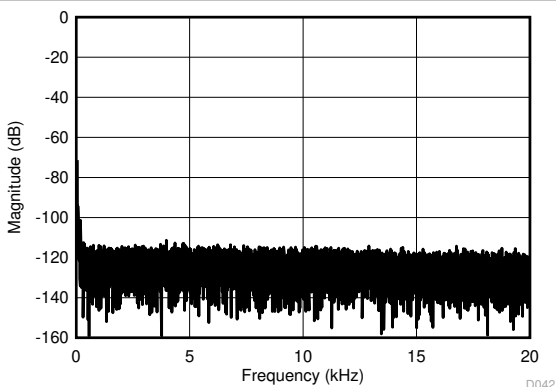

AMC1303x0520, capture time = 839ms,  $V_{IN} = 100\text{mV}_{PP}$

**Figure 6-32. Frequency Spectrum With 35Hz Input Signal**

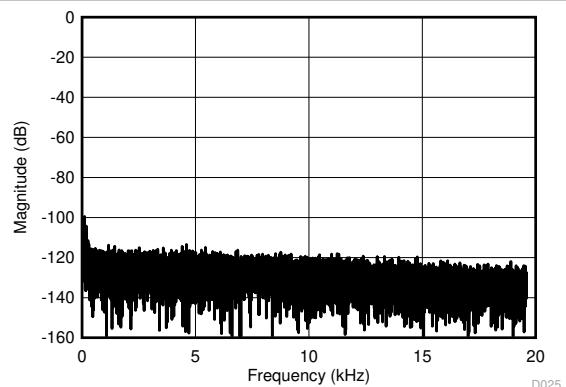

AMC1303x2510, capture time = 839ms,  $V_{IN} = 500\text{mV}_{PP}$

**Figure 6-33. Frequency Spectrum With 35Hz Input Signal**

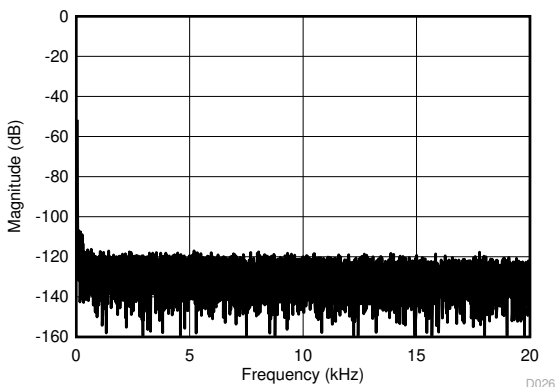

AMC1303x2520, capture time = 839ms,  $V_{IN} = 500\text{mV}_{PP}$

**Figure 6-34. Frequency Spectrum With 35Hz Input Signal**

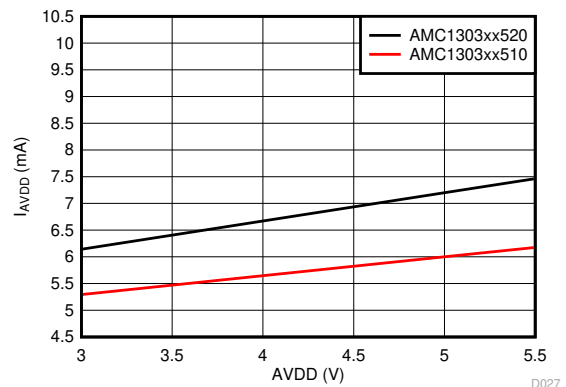

**Figure 6-35. High-Side Supply Current vs High-Side Supply Voltage**

### 6.14 Typical Characteristics (continued)

at  $T_A = 25^\circ\text{C}$ ,  $AVDD = 5\text{V}$ ,  $DVDD = 3.3\text{V}$ ,  $AINP = -50\text{mV}$  to  $50\text{mV}$  (AMC1303x05x) or  $-250\text{mV}$  to  $250\text{mV}$  (AMC1303x25x),  $AINN = AGND$ , and sinc<sup>3</sup> filter with  $OSR = 256$  (unless otherwise noted)

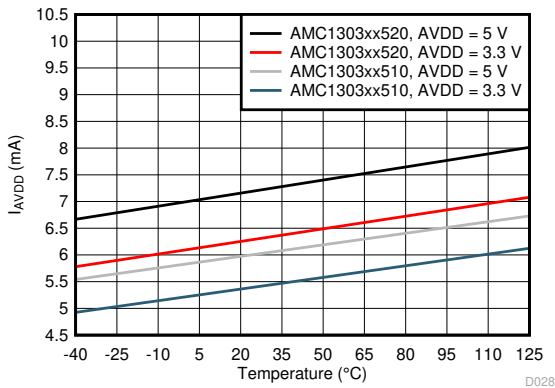

**Figure 6-36. High-Side Supply Current vs Temperature**

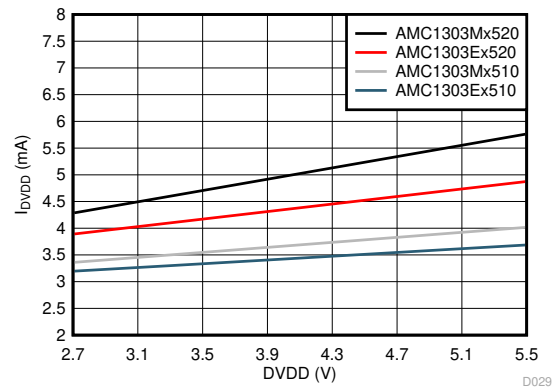

**Figure 6-37. Controller-Side Supply Current vs Controller-Side Supply Voltage**

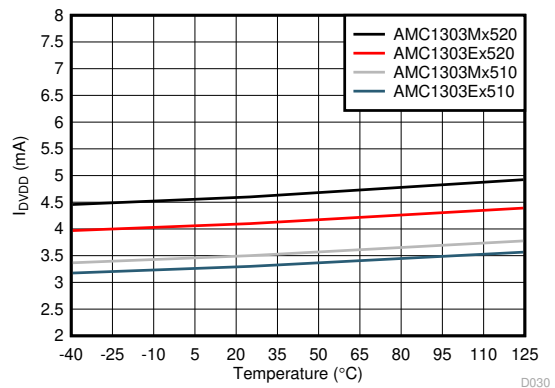

**Figure 6-38. Controller-Side Supply Current vs Temperature**

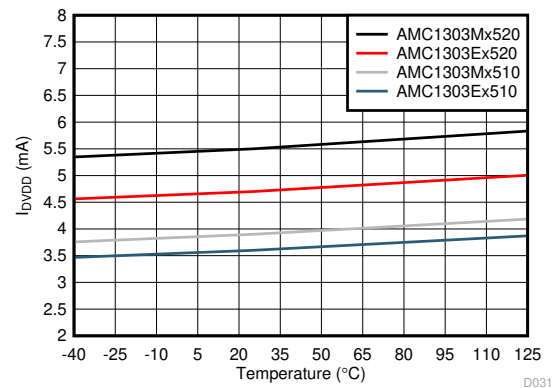

**Figure 6-39. Controller-Side Supply Current vs Temperature**

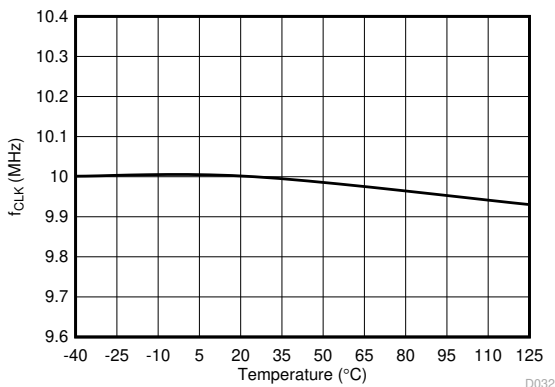

**Figure 6-40. Output Clock Frequency vs Temperature**

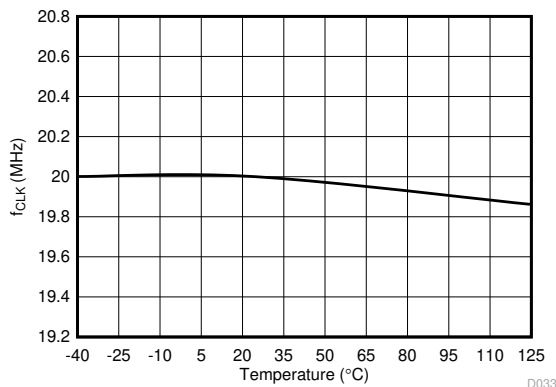

**Figure 6-41. Output Clock Frequency vs Temperature**

## 7 Detailed Description

### 7.1 Overview

The analog input stage of the AMC1303 is a fully differential amplifier feeding the switched-capacitor input of a second-order, delta-sigma ( $\Delta\Sigma$ ) modulator stage that digitizes the input signal into a 1-bit output stream. The isolated data output DOUT of the converter provides a stream of digital ones and zeros that is synchronous to the internally-generated clock at the CLKOUT pin (active on AMC1303Mx derivatives only) with a frequency as specified in the [Switching Characteristics](#) table. The time average of this serial bit-stream output is proportional to the analog input voltage.

The [Functional Block Diagram](#) section shows a detailed block diagram of the AMC1303. The analog input range is tailored to directly accommodate a voltage drop across a shunt resistor used for current sensing. The SiO<sub>2</sub>-based capacitive isolation barrier supports a high level of magnetic field immunity as described in the [ISO72x Digital Isolator Magnetic-Field Immunity application note](#), available for download at [www.ti.com](http://www.ti.com). The extended clock frequency of 20MHz on the AMC1303xxx20 supports faster control loops and higher performance levels compared to the other solutions available on the market.

### 7.2 Functional Block Diagram

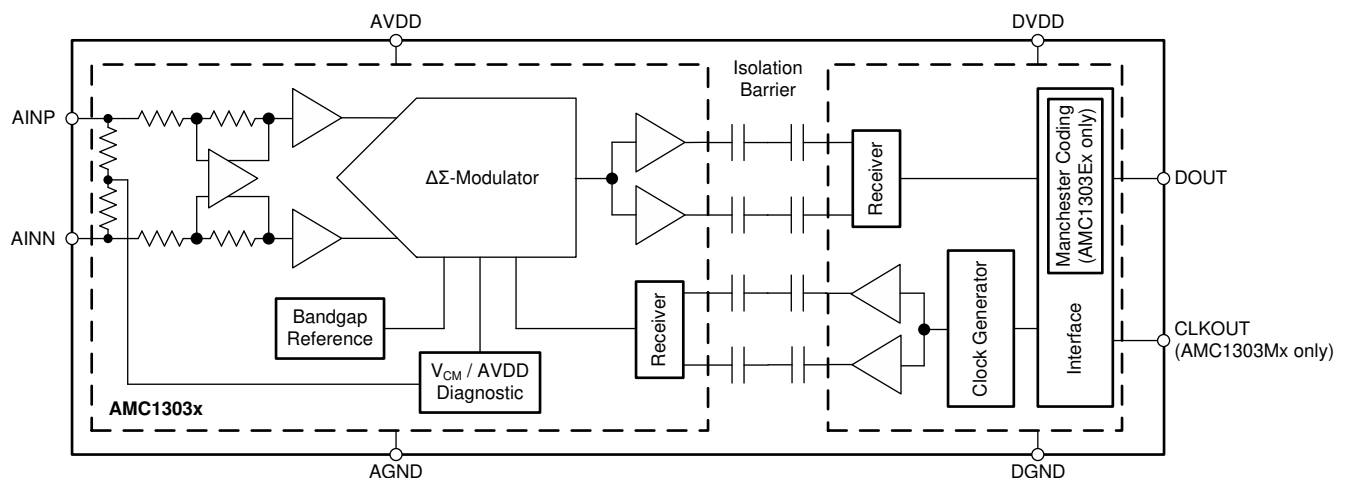

## 7.3 Feature Description

### 7.3.1 Analog Input

The AMC1303 incorporates a front-end circuitry that contains a differential amplifier and sampling stage, followed by a  $\Delta\Sigma$  modulator. The gain of the differential amplifier is set by internal precision resistors to a factor of 4 for devices with a specified input voltage range of  $\pm 250\text{mV}$  (for the AMC1303x25x), or to a factor of 20 in devices with a  $\pm 50\text{mV}$  input voltage range (for the AMC1303x05x), resulting in a differential input resistance of  $4.9\text{k}\Omega$  (for the AMC1303x05x) or  $22\text{k}\Omega$  (for the AMC1303x25x).

For reduced offset and offset drift, the differential amplifier is chopper-stabilized with the switching frequency set at  $625\text{kHz}$ . [Figure 7-1](#) shows that the switching frequency generates a spur.

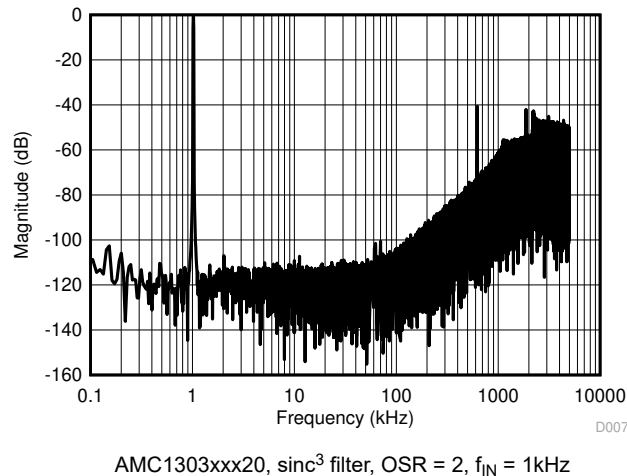

**Figure 7-1. Quantization Noise Shaping**

Consider the input resistance of the AMC1303 in designs with high-impedance signal sources that cause degradation of gain and offset specifications. The importance of this effect, however, depends on the desired system performance. Additionally, the input bias current caused by the internal common-mode voltage at the output of the differential amplifier causes an offset that is dependent on the actual amplitude of the input signal. See the [Isolated Voltage Sensing](#) section for more details on reducing these effects.

There are two restrictions on the analog input signals (AINP and AINN). First, if the input voltage exceeds the range  $\text{AGND} - 6\text{V}$  to  $\text{AVDD} + 0.5\text{V}$ , limit the input current to  $10\text{mA}$  because the device input electrostatic discharge (ESD) diodes turn on. In addition, the linearity and noise performance of the device are specified only when the differential analog input voltage remains within the specified linear full-scale range (FSR), that is  $\pm 250\text{mV}$  (for the AMC1303x25x) or  $\pm 50\text{mV}$  (for the AMC1303x05x), and within the specified input common-mode voltage range.

### 7.3.2 Modulator

The modulator implemented in the AMC1303 (such as the one conceptualized in Figure 7-2) is a second-order, switched-capacitor, feed-forward  $\Delta\Sigma$  modulator. The analog input voltage  $V_{IN}$  and the output  $V_5$  of the 1-bit digital-to-analog converter (DAC) are subtracted, providing an analog voltage  $V_1$  at the input of the first integrator stage. The output of the first integrator feeds the input of the second integrator stage, resulting in output voltage  $V_3$  that is subtracted from the input signal  $V_{IN}$  and the output of the first integrator  $V_2$ . Depending on the polarity of the resulting voltage  $V_4$ , the output of the comparator is changed. In this case, the 1-bit DAC responds on the next clock pulse by changing its analog output voltage  $V_5$ , causing the integrators to progress in the opposite direction and forcing the value of the integrator output to track the average value of the input.

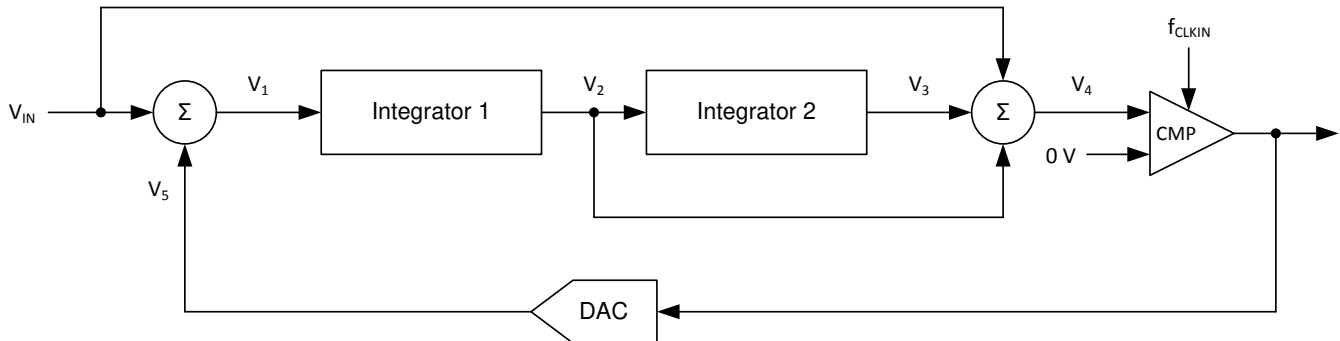
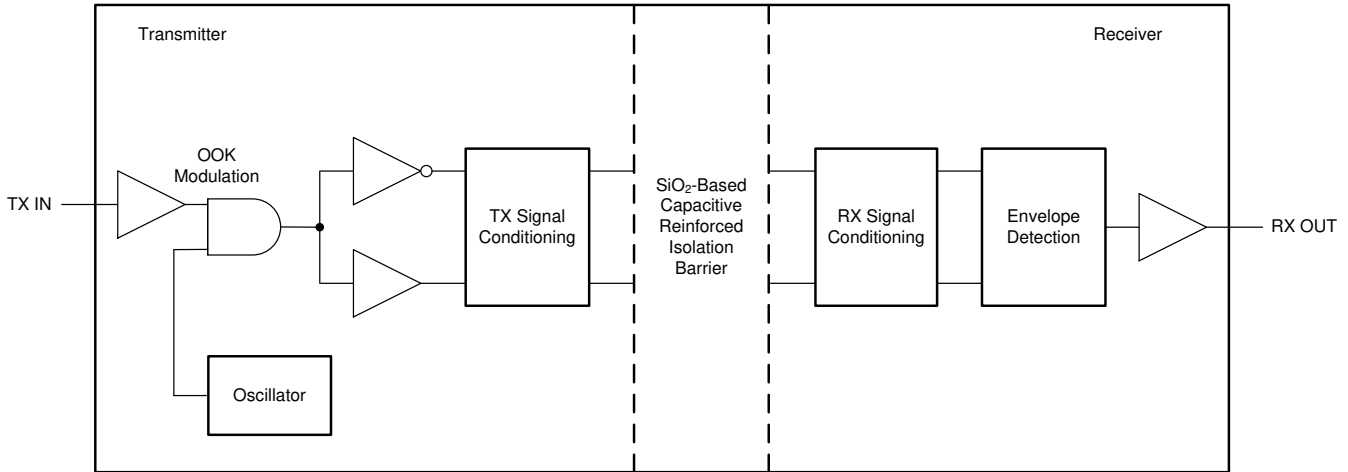

**Figure 7-2. Block Diagram of a Second-Order Modulator**

The modulator shifts the quantization noise to high frequencies; see Figure 7-1. Therefore, use a low-pass digital filter at the output of the device to increase the overall performance. This filter is also used to convert the 1-bit data stream at a high sampling rate into a higher-bit data word at a lower rate (decimation). TI's microcontroller families [TMS320F2807x](#) and [TMS320F2837x](#) offer a suitable programmable, hardwired filter structure called a *sigma-delta filter module* (SDFM) optimized for usage with the AMC1303 family. Also, SD24\_B converters on the [MSP430F677x](#) microcontrollers offer a path to directly access the integrated sinc-filters, thus offering a system-level solution for multichannel, isolated current sensing. An additional option using an appropriate application-specific device, such as the [AMC1210](#) (a four-channel digital sinc-filter). Alternatively, use a field-programmable gate array (FPGA) to implement the filter.

### 7.3.3 Isolation Channel Signal Transmission

The AMC1303 uses an on-off keying (OOK) modulation scheme to transmit the modulator output bitstream across the capacitive SiO<sub>2</sub>-based isolation barrier. The transmitter modulates the bitstream at TX IN in Figure 7-3 with an internally generated, 480MHz carrier across the isolation barrier to represent a digital zero and sends a *no signal* to represent the digital one. The receiver demodulates the signal after advanced signal conditioning and produces the output. The symmetrical design of each isolation channel improves the CMTI performance and reduces the radiated emissions caused by the high-frequency carrier. Figure 7-3 shows a block diagram of an isolation channel integrated in the AMC1303.



**Figure 7-3. Block Diagram of an Isolation Channel**

Figure 7-4 shows the concept of the on-off keying scheme.

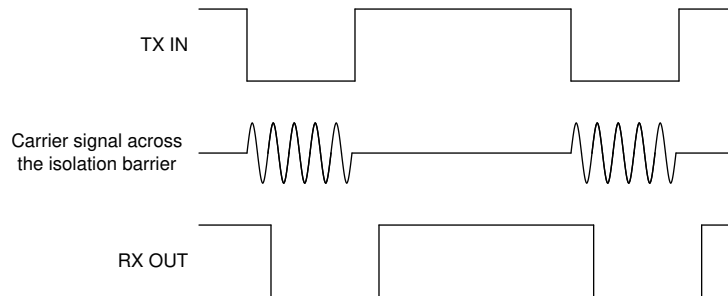

**Figure 7-4. OOK-Based Modulation Scheme**

### 7.3.4 Digital Output

A differential input signal of 0V ideally produces a stream of ones and zeros that are high 50% of the time. A differential input of 250mV (for the AMC1303x25x) or 50 mV (for the AMC1303x05x) produces a stream of ones and zeros that are high 89.06% of the time. With 16 bits of resolution on the decimation filter, that percentage ideally corresponds to code 58368. A differential input of –250mV (–50mV for the AMC1303x05x) produces a stream of ones and zeros that are high 10.94% of the time and ideally results in code 7168 with a 16-bit resolution decimation filter. These input voltages are also the specified linear ranges of the different AMC1303 versions with performance as specified in this document. If the input voltage value exceeds these ranges, the output of the modulator shows nonlinear behavior where the quantization noise increases. The output of the modulator clips with a stream of only zeros with an input less than or equal to –320mV (–64mV for the AMC1303x05x) or with a stream of only ones with an input greater than or equal to 320mV (64mV for the AMC1303x05x). In this case, however, the AMC1303 generates a single 1 (if the input is at negative full-scale) or 0 every 128 clock cycles to indicate proper device function (see the [Fail-Safe Output](#) section for more details). [Figure 7-5](#) shows the input voltage versus the output modulator signal.

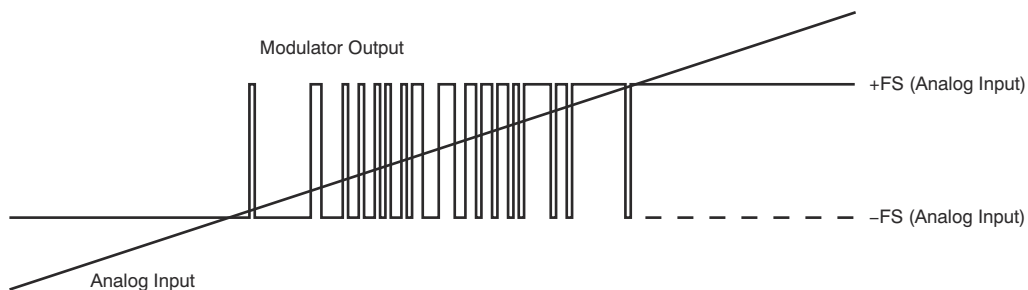

**Figure 7-5. Analog Input versus AMC1303 Modulator Output**

[Equation 1](#) calculates the density of ones in the output bitstream for any input voltage value (with the exception of a full-scale input signal, as described in the [Section 7.4.2](#) section):

$$\frac{V_{IN} + V_{Clipping}}{2 \times V_{Clipping}} \quad (1)$$

The AMC1303 internally generates the clock signal required for the modulator. This clock is provided externally at the CLKOUT pin on AMC1303Mx devices only. For more details, see the [Switching Characteristics](#) section.

### 7.3.5 Manchester Coding Feature

The AMC1303Ex offers the IEEE 802.3-compliant Manchester-coding feature that generates at least one transition per bit to support clock signal recovery from the bitstream. A Manchester-coded bitstream is free of dc components. The Manchester coding combines the clock and data information using exclusive or (XOR) logical operation. [Figure 7-6](#) shows the resulting bitstream.

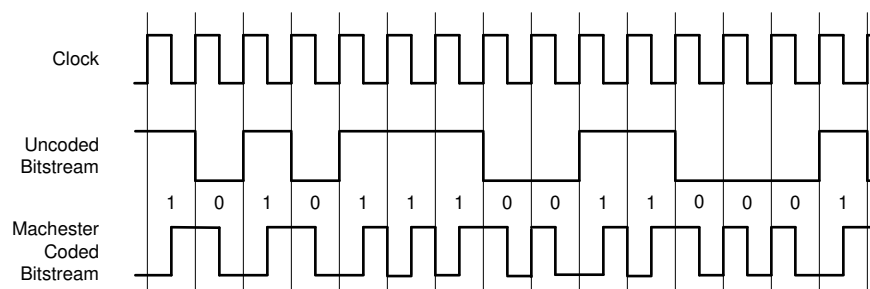

**Figure 7-6. Manchester-Coded Output of the AMC1303Ex**



## 7.4 Device Functional Modes

### 7.4.1 Fail-Safe Output

In the case of a missing high-side supply voltage AVDD, the output of the  $\Delta\Sigma$  modulator is not defined and can cause a system malfunction. In systems with high safety requirements, this behavior is not acceptable. Therefore, the AMC1303 implements a fail-safe output function that pulls the DOUT and CLKOUT outputs (AMC1303Mx only) to a steady-state logic 1 in case of a missing AVDD; see [Figure 6-2](#).

Similarly, as also shown in [Figure 7-7](#), if the common-mode voltage of the input reaches or exceeds the specified common-mode overvoltage detection level  $V_{CMov}$  as defined in the [Electrical Characteristics](#) table, the AMC1303 generates a steady-state bitstream of logic 1's at the DOUT output.

In both cases, the steady-state logic 1 occurs on the DOUT output with a delay of two clock cycles after the event of either exceeded common-mode input voltage or missing AVDD. Another 256 clock cycles are required for the CLKOUT pin of the AMC1303Mx to be held at logic 1.

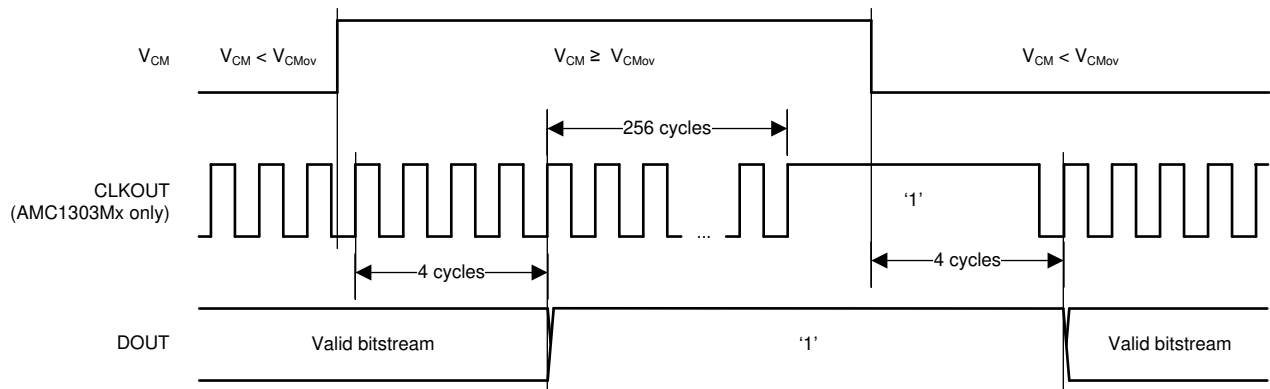

**Figure 7-7. Fail-Safe Output of the AMC1303**

### 7.4.2 Output Behavior in Case of a Full-Scale Input

When an input signal is applied to the AMC1303 that exceeds the clipping voltage ( $|V_{IN}| \geq |V_{Clipping}|$ ), the AMC1303 outputs a bitstream as shown in [Figure 7-8](#). A zero or one is generated every 128th clock cycle depending on the actual polarity of the signal being sensed. In this way, differentiating between a missing AVDD and a full-scale input signal is possible on the system level.

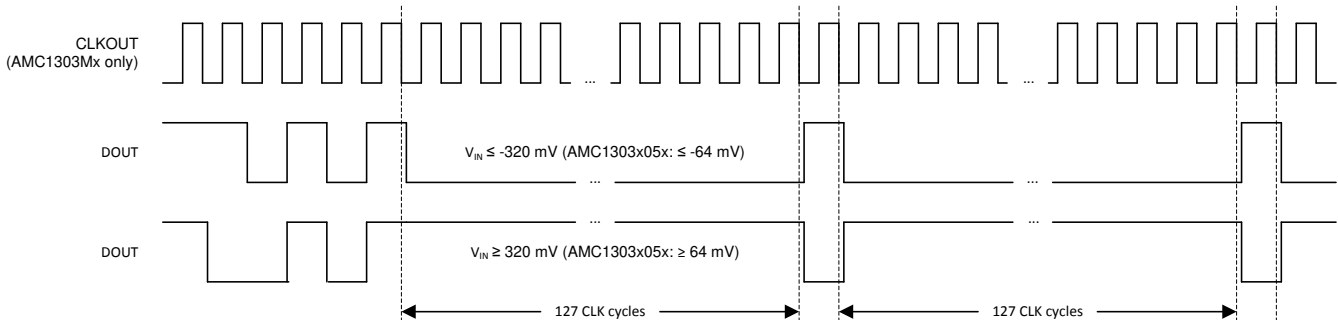

**Figure 7-8. Overrange Output of the AMC1303**

## 8 Application and Implementation

### Note

Information in the following applications sections is not part of the TI component specification, and TI does not warrant its accuracy or completeness. TI's customers are responsible for determining suitability of components for their purposes, as well as validating and testing their design implementation to confirm system functionality.

### 8.1 Application Information

#### 8.1.1 Digital Filter Usage

The modulator generates a bitstream that is processed by a digital filter to obtain a digital word similar to a conversion result of a conventional analog-to-digital converter (ADC). A very simple filter, shown in Equation 2, built with minimal effort and hardware, is a sinc<sup>3</sup>-type filter:

$$H(z) = \left( \frac{1 - z^{-OSR}}{1 - z^{-1}} \right)^3 \quad (2)$$

This filter provides the best output performance at the lowest hardware size (count of digital gates) for a second-order modulator. All the characterization in this document is done with a sinc<sup>3</sup> filter with an oversampling ratio (OSR) of 256 and an output word size of 16 bits.

The effective number of bits (ENOB) is often used to compare the performance of ADCs and  $\Delta\Sigma$  modulators. Figure 8-1 shows the ENOB of the AMC1303 with different oversampling ratios. In this document, Equation 3 calculates this number from the SINAD by using the following equation:

$$\text{SINAD} = 1.76 + 6.02\text{dB} \times \text{ENOB} \quad (3)$$

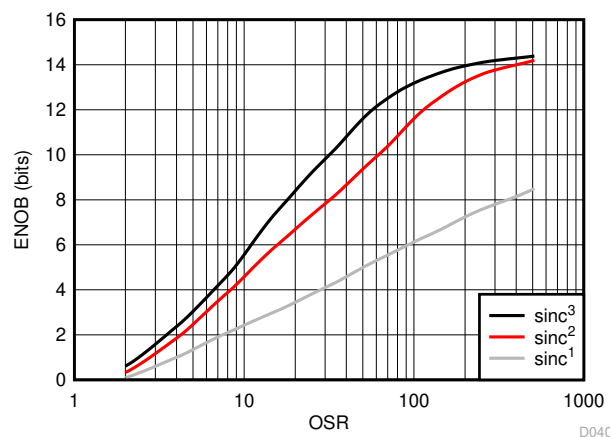

**Figure 8-1. Measured Effective Number of Bits versus Oversampling Ratio**

An example code for implementing a sinc<sup>3</sup> filter in an FPGA is discussed in the [Combining ADS1202 with FPGA Digital Filter for Current Measurement in Motor Control Applications](#) application note, available for download at [www.ti.com](http://www.ti.com).

## 8.2 Typical Applications

### 8.2.1 Frequency Inverter Application

Isolated  $\Delta\Sigma$  modulators are widely used in frequency inverter designs because of the device high ac and dc performance. Frequency inverters are critical parts of industrial motor drives, photovoltaic inverters (string and central inverters), uninterruptible power supplies (UPS), and other industrial applications.

Figure 8-2 shows a simplified schematic of the AMC1303Mx in a typical frequency inverter application as used in industrial motor drives with shunt resistors ( $R_{SHUNT}$ ) used for current sensing. Depending on the system design, either all three or only two motor phase currents are sensed.

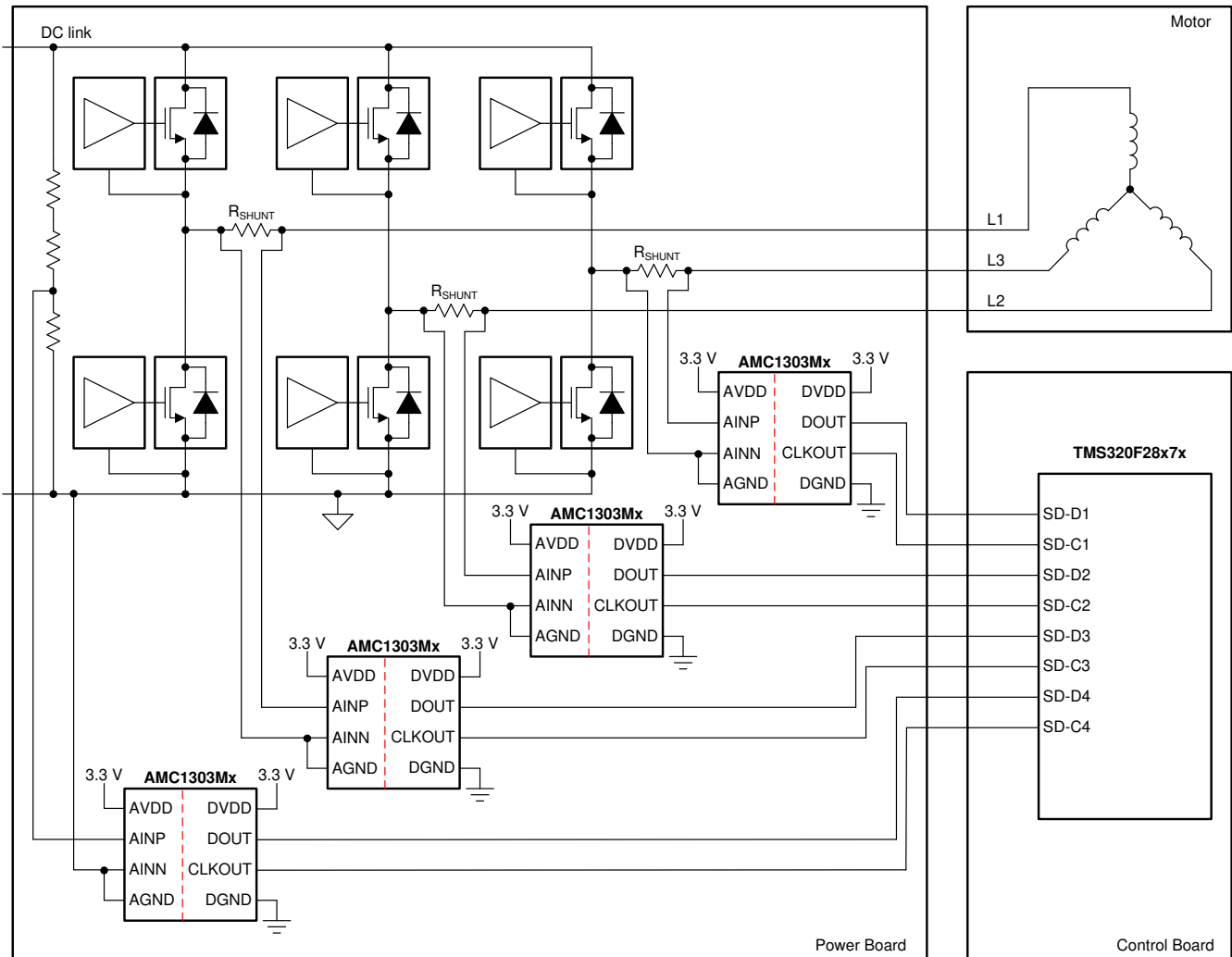

**Figure 8-2. Simplified Diagram of the AMC1303Mx in a Frequency Inverter Application**

Figure 8-3 shows how the Manchester-coded bitstream output of the AMC1303Ex minimizes the wiring efforts of the connection between the power and the control board. This bitstream output also allows the clock to be generated locally on the power board without the having to adjust the propagation delay time of each DOUT connection to fulfill the setup and hold time requirements of the microcontroller.

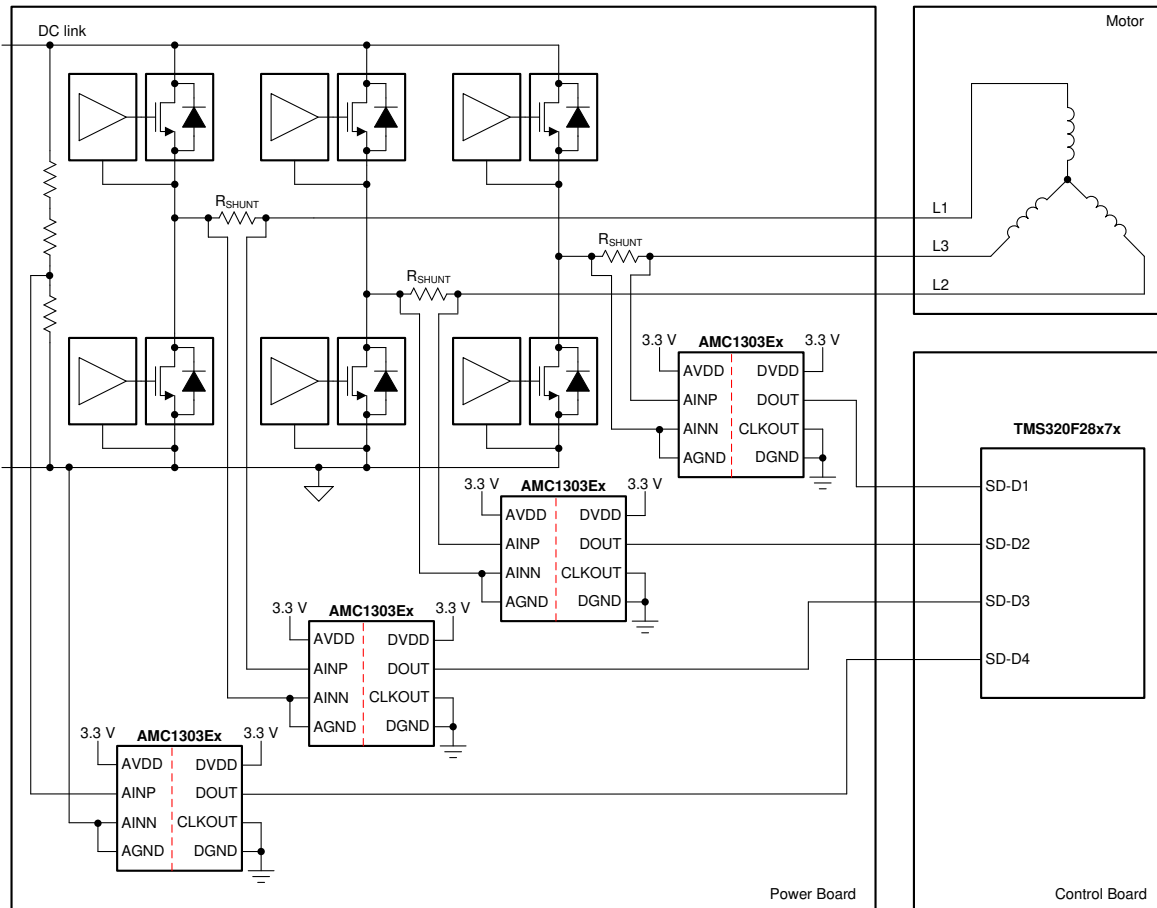

**Figure 8-3. Simplified Diagram of the AMC1303Ex in a Frequency Inverter Application**

In both examples shown previously, an additional fourth AMC1303 is used to support isolated voltage sensing of the dc link. This high voltage is reduced using a resistive divider and is sensed by the device across a smaller resistor. The value of this resistor degrades the performance of the measurement, as described in the [Isolated Voltage Sensing](#) section.

### 8.2.1.1 Design Requirements

Table 8-1 lists the parameters for the typical application in the [Frequency Inverter Application](#) section.

**Table 8-1. Design Requirements**

PARAMETER	VALUE
High-side supply voltage	3.3V or 5V
Low-side supply voltage	3.3V or 5V
Voltage drop across the shunt for a linear response	AMC1303x25x: $\pm 250\text{mV}$ (maximum)
	AMC1303x05x: $\pm 50\text{mV}$ (maximum)

### 8.2.1.2 Detailed Design Procedure

The high-side power supply (AVDD) for the AMC1303 device is derived from the power supply of the upper gate driver. Further details are provided in the [Power Supply Recommendations](#) section.

The floating ground reference (AGND) is derived from one of the ends of the shunt resistor that is connected to the negative input of the AMC1303 (AINN). If a four-pin shunt is used, the inputs of the device are connected to the inner leads and AGND is connected to one of the outer shunt leads.

Use Ohm's Law to calculate the voltage drop across the shunt resistor ( $V_{SHUNT}$ ) for the desired measured current:  $V_{SHUNT} = I \times R_{SHUNT}$ .

Consider the following two restrictions to choose the proper value of the shunt resistor  $R_{SHUNT}$ :

- Make sure the voltage drop caused by the nominal current range does not exceed the recommended differential input voltage range:  $V_{SHUNT} \leq \pm 250\text{mV}$
- Make sure the voltage drop caused by the maximum allowed overcurrent does not exceed the input voltage that causes a clipping output:  $|V_{SHUNT}| \leq |V_{Clipping}|$

The typically recommended RC filter in front of a  $\Delta\Sigma$  modulator to improve signal-to-noise performance of the signal path is not required for the AMC1303. By design, the input bandwidth of the analog front-end of the device is limited as specified in the [Electrical Characteristics](#) table.

For modulator output bitstream filtering, use a device from TI's [TMS320F2807x](#) family of low-cost microcontrollers (MCUs) or [TMS320F2837x](#) family of dual-core MCUs. These families support up to eight channels of dedicated hardwired filter structures that significantly simplify system level design by offering two filtering paths per channel: one providing high accuracy results for the control loop and one fast response path for overcurrent detection.

### 8.2.1.3 Application Curves

In motor control applications, a very fast response time for overcurrent detection is required. The time for fully settling the filter in case of a step-signal at the input of the modulator depends on the order; that is, a  $\text{sinc}^3$  filter requires three data updates for full settling (with  $f_{DATA} = f_{CLK} / \text{OSR}$ ). Therefore, for overcurrent protection,  $\text{sinc}^2$  filters with a lower OSR are a better choice. [Figure 8-4](#) and [Figure 8-5](#) compare the settling times of different filter orders.

The delay time of a  $\text{sinc}$  filter with a continuous signal is half the settling time.

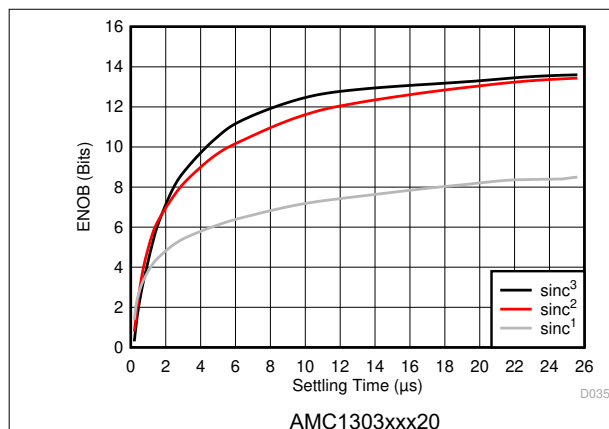

**Figure 8-4. Measured Effective Number of Bits versus Settling Time**

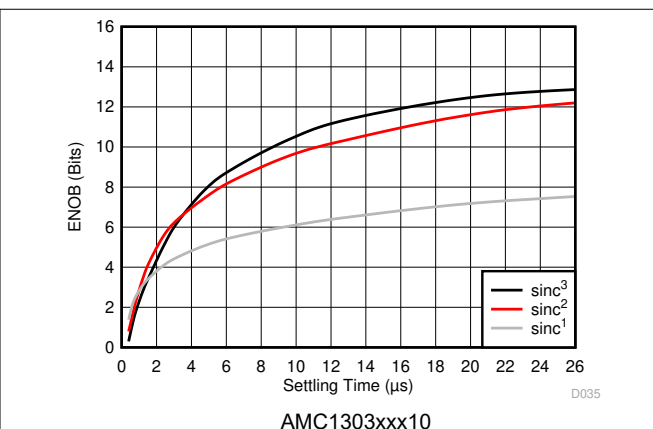

**Figure 8-5. Measured Effective Number of Bits versus Settling Time**

## 8.2.2 Isolated Voltage Sensing

The AMC1303 is optimized for usage in current-sensing applications using low-resistance shunts. However, the device is also suitable for isolated voltage-sensing applications as long as the effect of the input bias current is considered. For best performance, use the  $\pm 250\text{mV}$  versions of the device (AMC1303x25xx) in this case.

Figure 8-6 shows a simplified circuit typically used in high-voltage-sensing applications. The high value resistors (R1 and R2) are used as voltage dividers and dominate the current value definition. The resistance of the sensing resistor R3 is chosen to meet the input voltage range of the AMC1303. This resistor and the differential input resistance of the AMC1303x25x is  $22\text{k}\Omega$  also create a voltage divider that results in an additional gain error. With the assumption of R1, R2, and  $R_{\text{IND}}$  having a considerably higher value than R3, the resulting total gain error is estimated using Equation 4, with  $E_G$  being the gain error of the AMC1303.

$$|E_{\text{Gtot}}| = |E_G| + \frac{R3}{R_{\text{IN}}} \quad (4)$$

This gain error is minimized during the initial system-level gain calibration procedure.

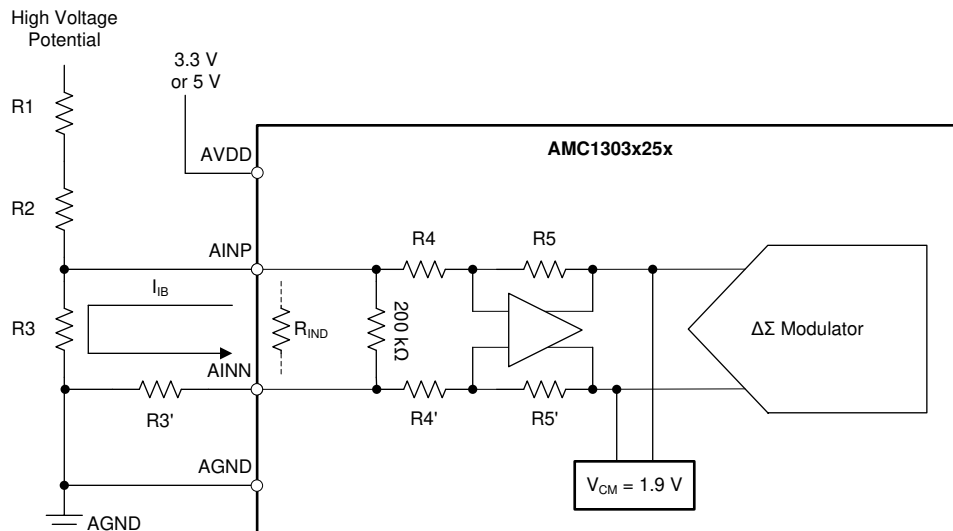

**Figure 8-6. Using the AMC1303x25x for Isolated Voltage Sensing**

### 8.2.2.1 Design Requirements

Table 8-2 lists the parameters for the typical application in the *Isolated Voltage Sensing* section.

**Table 8-2. Design Requirements**

PARAMETER	VALUE
High-side supply voltage	3.3V or 5V
Low-side supply voltage	3.3V or 5V
Voltage drop across the resistor R3 for a linear response	AMC1303x25x: $\pm 250\text{mV}$ (maximum)

### 8.2.2.2 Detailed Design Procedure

As indicated in Figure 8-6, the output of the integrated differential amplifier is internally biased to a common-mode voltage of  $1.9\text{V}$ . This voltage results in a bias current  $I_B$  through the resistive network R4 and R5 (or R4' and R5') used for setting the gain of the amplifier. The value range of this current is specified in the *Electrical Characteristics* table. This bias current generates additional offset error that depends on the value of the resistor

R3. Because the value of this bias current depends on the actual common-mode amplitude of the input signal (as illustrated in Figure 8-7), the initial system offset calibration does not minimize the effect. Therefore, in systems with high accuracy requirements, use a series resistor at the negative input (AINN) of the AMC1303 with a value equal to the shunt resistor R3 (that is,  $R3' = R3$  in Figure 8-6) to eliminate the effect of the bias current.

This additional series resistor ( $R3'$ ) influences the gain error of the circuit. The effect is calculated using Equation 5 with  $R5 = R5' = 50k\Omega$  and  $R4 = R4' = 12.5k\Omega$  for the AMC1303x25x.

$$E_G(\%) = \left(1 - \frac{R4}{R4' + R3'}\right) \times 100\% \tag{5}$$

### 8.2.2.3 Application Curve

Figure 8-7 shows the dependency of the input bias current on the common-mode voltage at the input of the AMC1303x25x.

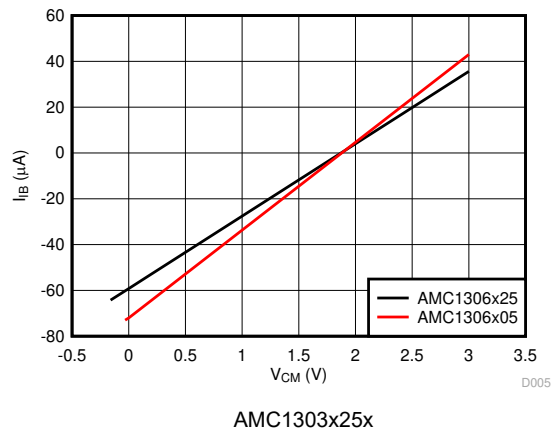

**Figure 8-7. Input Current vs Input Common-Mode Voltage**

### 8.2.3 Best Design Practices

Do not leave the inputs of the AMC1303 unconnected (floating) when the device is powered up. If both modulator inputs are left floating, the input bias current drives these inputs to the output common-mode voltage of the differential amplifier of approximately 1.9V. If that voltage is above the specified input common-mode range, the gain of the differential amplifier diminishes and the modulator outputs a bitstream resembling a zero differential input voltage.

### 8.3 Power Supply Recommendations

In a typical frequency-inverter application, the device high-side power supply (AVDD) is directly derived from the floating power supply of the upper gate driver. For lowest system-level cost, use a Zener diode to limit the voltage to 5V or 3.3V ( $\pm 10\%$ ). Alternatively, use a low-cost, low-drop regulator (LDO), for example the LM317-N, to adjust the supply voltage level and minimize noise on the power-supply node. Use a 0.1 $\mu$ F, low-ESR decoupling capacitor to filter this power-supply path. Place this capacitor (C2 in Figure 8-8) as close as possible to the AVDD pin of the AMC1303 for best performance. Further, use an additional capacitor with a value in the range of 2.2 $\mu$ F to 10 $\mu$ F.

The floating ground reference (AGND) is derived from the end of the shunt resistor, which is connected to the negative input (AINN) of the device. If using a four-pin shunt, connect the inputs of the device to the sense terminals of the shunt. Route the ground connection as a separate trace to the shunt to minimize offset and improve accuracy.

To decouple the digital power supply on the controller side, use a 0.1 $\mu$ F and 2.2 $\mu$ F capacitor placed as close to the DVDD pin of the AMC1303 as possible.

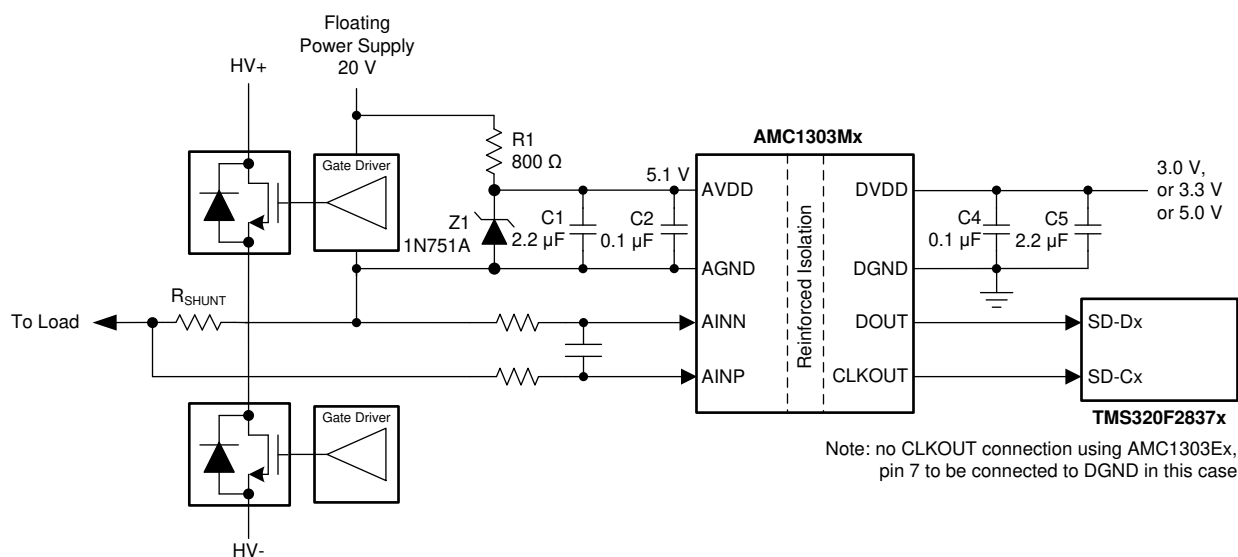

**Figure 8-8. Decoupling the AMC1303**



## 8.4 Layout

### 8.4.1 Layout Guidelines

Figure 8-9 shows a layout recommendation detailing the critical placement of the decoupling capacitors (as close as possible to the AMC1303). This figure also shows the placement of other components required by the device. For best performance, place the shunt resistor and the antialiasing filter components as close as possible to the AINP and AINN inputs of the AMC1303. Keep the layout of both connections symmetrical.

### 8.4.2 Layout Example

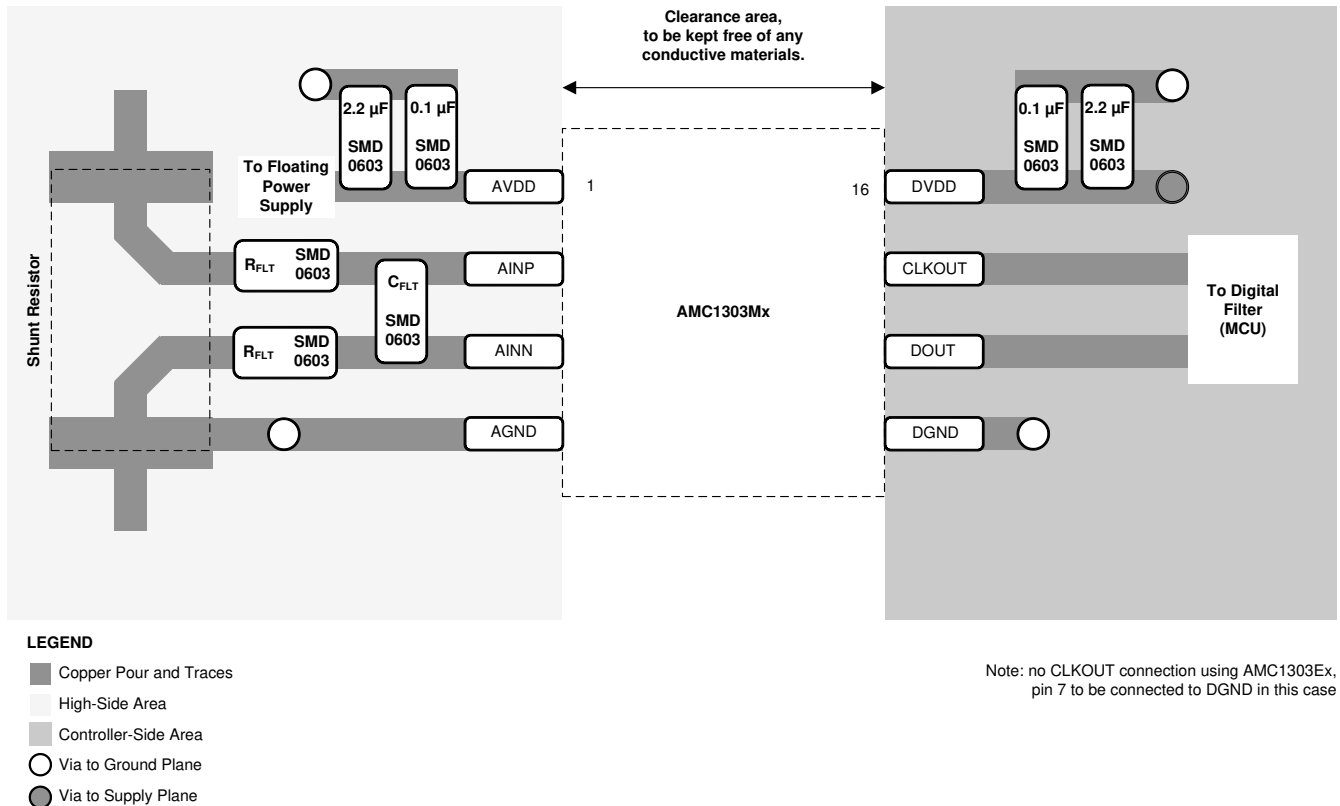

**Figure 8-9. Recommended Layout of the AMC1303**

## 9 Device and Documentation Support

### 9.1 Device Support

#### 9.1.1 Device Nomenclature

##### 9.1.1.1 Isolation Glossary

See the [Isolation Glossary](#)

### 9.2 Documentation Support

#### 9.2.1 Related Documentation

- Texas Instruments, [AMC1210 Quad Digital Filter for 2nd-Order Delta-Sigma Modulator data sheet](#)
- Texas Instruments, [MSP430F677x Polyphase Metering SoCs data sheet](#)
- Texas Instruments, [TMS320F2807x Piccolo™ Microcontrollers data sheet](#)
- Texas Instruments, [TMS320F2837xD Dual-Core Delfino™ Microcontrollers data sheet](#)
- Texas Instruments, [ISO72x Digital Isolator Magnetic-Field Immunity application note](#)
- Texas Instruments, [Combining ADS1202 with FPGA Digital Filter for Current Measurement in Motor Control Applications application note](#)

### 9.3 Receiving Notification of Documentation Updates

To receive notification of documentation updates, navigate to the device product folder on [ti.com](#). Click on *Notifications* to register and receive a weekly digest of any product information that has changed. For change details, review the revision history included in any revised document.

### 9.4 Support Resources

[TI E2E™ support forums](#) are an engineer's go-to source for fast, verified answers and design help — straight from the experts. Search existing answers or ask your own question to get the quick design help you need.

Linked content is provided "AS IS" by the respective contributors. They do not constitute TI specifications and do not necessarily reflect TI's views; see TI's [Terms of Use](#).

### 9.5 Trademarks

TI E2E™ is a trademark of Texas Instruments.

All trademarks are the property of their respective owners.

### 9.6 Electrostatic Discharge Caution



This integrated circuit can be damaged by ESD. Texas Instruments recommends that all integrated circuits be handled with appropriate precautions. Failure to observe proper handling and installation procedures can cause damage.

ESD damage can range from subtle performance degradation to complete device failure. Precision integrated circuits may be more susceptible to damage because very small parametric changes could cause the device not to meet its published specifications.

### 9.7 Glossary

[TI Glossary](#) This glossary lists and explains terms, acronyms, and definitions.

## 10 Revision History

NOTE: Page numbers for previous revisions may differ from page numbers in the current version.

Changes from Revision C (February 2020) to Revision D (October 2024)	Page
• Changed isolation standard from <i>DIN VDE V 0884-11 (VDE V 0884-11)</i> to <i>DIN EN IEC 60747-17 (VDE 0884-17)</i> and updated the <i>Insulation Specifications</i> and <i>Safety-Related Certifications</i> tables accordingly.....	1
• Added AMC1303M2520F device to Device Comparison Table .....	3
• Changed chopper frequency from $f_{CLK} / 32$ to fixed 625kHz.....	21
• Changed <i>Output Behavior in Case of a Full-Scale Input</i> section.....	25

<b>Changes from Revision B (June 2018) to Revision C (February 2020)</b>	<b>Page</b>
• Changed <i>Safety-related certifications</i> bullet in <i>Features</i> section: changed VDE certification revision from <i>DIN V VDE V 0884-10 (VDE V 0884-11)</i> to <i>DIN VDE V 0884-11</i> and changed <i>IEC 60950-1</i> , and <i>IEC 60065</i> to <i>IEC 62368-1</i> .....	1
• Changed <i>DIN V VDE V</i> to <i>DIN VDE V</i> in <i>Description</i> section .....	1
• Changed CLR and CPG values from $\geq 9$ mm to $\geq 8.5$ mm in <i>Insulation Specifications</i> table .....	6
• Changed <i>Insulation Specifications</i> table header row from <i>DIN V VDE V 0884-11 (VDE V 0884-11): 2017-01</i> to <i>DIN VDE V 0884-11: 2017-01</i> .....	6
• Changed VDE certification details in <i>Safety-Related Certifications</i> table .....	7
• Changed <i>Safety Limiting Values</i> table format as per current standard .....	7
• Changed <i>Functional Block Diagram</i> to include input resistors used for VCM diagnostic.....	20
• Changed <i>Equation 3</i> and text reference in <i>Digital Filter Usage</i> section.....	26

## 11 Mechanical, Packaging, and Orderable Information

The following pages include mechanical, packaging, and orderable information. This information is the most current data available for the designated devices. This data is subject to change without notice and revision of this document. For browser-based versions of this data sheet, refer to the left-hand navigation.

**PACKAGING INFORMATION**

Orderable Device	Status (1)	Package Type	Package Drawing	Pins	Package Qty	Eco Plan (2)	Lead finish/ Ball material (6)	MSL Peak Temp (3)	Op Temp (°C)	Device Marking (4/5)	Samples
AMC1303E0510DWV	ACTIVE	SOIC	DWV	8	64	RoHS & Green	NIPDAU	Level-3-260C-168 HR	-40 to 125	1303E051	<a href="#">Samples</a>
AMC1303E0510DWVR	ACTIVE	SOIC	DWV	8	1000	RoHS & Green	NIPDAU	Level-3-260C-168 HR	-40 to 125	1303E051	<a href="#">Samples</a>
AMC1303E0520DWV	ACTIVE	SOIC	DWV	8	64	RoHS & Green	NIPDAU	Level-3-260C-168 HR	-40 to 125	1303E052	<a href="#">Samples</a>
AMC1303E0520DWVR	ACTIVE	SOIC	DWV	8	1000	RoHS & Green	NIPDAU	Level-3-260C-168 HR	-40 to 125	1303E052	<a href="#">Samples</a>
AMC1303E2510DWV	ACTIVE	SOIC	DWV	8	64	RoHS & Green	NIPDAU	Level-3-260C-168 HR	-40 to 125	1303E251	<a href="#">Samples</a>
AMC1303E2510DWVR	ACTIVE	SOIC	DWV	8	1000	RoHS & Green	NIPDAU	Level-3-260C-168 HR	-40 to 125	1303E251	<a href="#">Samples</a>
AMC1303E2520DWV	ACTIVE	SOIC	DWV	8	64	RoHS & Green	NIPDAU	Level-3-260C-168 HR	-40 to 125	1303E252	<a href="#">Samples</a>
AMC1303E2520DWVR	ACTIVE	SOIC	DWV	8	1000	RoHS & Green	NIPDAU	Level-3-260C-168 HR	-40 to 125	1303E252	<a href="#">Samples</a>
AMC1303M0510DWV	ACTIVE	SOIC	DWV	8	64	RoHS & Green	NIPDAU	Level-3-260C-168 HR	-40 to 125	1303M051	<a href="#">Samples</a>
AMC1303M0510DWVR	ACTIVE	SOIC	DWV	8	1000	RoHS & Green	NIPDAU	Level-3-260C-168 HR	-40 to 125	1303M051	<a href="#">Samples</a>
AMC1303M0520DWV	ACTIVE	SOIC	DWV	8	64	RoHS & Green	NIPDAU	Level-3-260C-168 HR	-40 to 125	1303M052	<a href="#">Samples</a>
AMC1303M0520DWVR	ACTIVE	SOIC	DWV	8	1000	RoHS & Green	NIPDAU	Level-3-260C-168 HR	-40 to 125	1303M052	<a href="#">Samples</a>
AMC1303M2510DWV	ACTIVE	SOIC	DWV	8	64	RoHS & Green	NIPDAU	Level-3-260C-168 HR	-40 to 125	1303M251	<a href="#">Samples</a>
AMC1303M2510DWVR	ACTIVE	SOIC	DWV	8	1000	RoHS & Green	NIPDAU	Level-3-260C-168 HR	-40 to 125	1303M251	<a href="#">Samples</a>
AMC1303M2520DWV	ACTIVE	SOIC	DWV	8	64	RoHS & Green	NIPDAU	Level-3-260C-168 HR	-40 to 125	1303M252	<a href="#">Samples</a>
AMC1303M2520DWVR	ACTIVE	SOIC	DWV	8	1000	RoHS & Green	NIPDAU	Level-3-260C-168 HR	-40 to 125	1303M252	<a href="#">Samples</a>
AMC1303M2520FDWVR	ACTIVE	SOIC	DWV	8	1000	RoHS & Green	NIPDAU	Level-3-260C-168 HR	40 to 125	303M252F	<a href="#">Samples</a>

(1) The marketing status values are defined as follows:

**ACTIVE:** Product device recommended for new designs.

**LIFEBUY:** TI has announced that the device will be discontinued, and a lifetime-buy period is in effect.

**NRND:** Not recommended for new designs. Device is in production to support existing customers, but TI does not recommend using this part in a new design.

**PREVIEW:** Device has been announced but is not in production. Samples may or may not be available.

**OBSOLETE:** TI has discontinued the production of the device.

(2) **RoHS:** TI defines "RoHS" to mean semiconductor products that are compliant with the current EU RoHS requirements for all 10 RoHS substances, including the requirement that RoHS substance do not exceed 0.1% by weight in homogeneous materials. Where designed to be soldered at high temperatures, "RoHS" products are suitable for use in specified lead-free processes. TI may reference these types of products as "Pb-Free".

**RoHS Exempt:** TI defines "RoHS Exempt" to mean products that contain lead but are compliant with EU RoHS pursuant to a specific EU RoHS exemption.

**Green:** TI defines "Green" to mean the content of Chlorine (Cl) and Bromine (Br) based flame retardants meet JS709B low halogen requirements of  $\leq 1000$ ppm threshold. Antimony trioxide based flame retardants must also meet the  $\leq 1000$ ppm threshold requirement.

(3) MSL, Peak Temp. - The Moisture Sensitivity Level rating according to the JEDEC industry standard classifications, and peak solder temperature.

(4) There may be additional marking, which relates to the logo, the lot trace code information, or the environmental category on the device.

(5) Multiple Device Markings will be inside parentheses. Only one Device Marking contained in parentheses and separated by a "~" will appear on a device. If a line is indented then it is a continuation of the previous line and the two combined represent the entire Device Marking for that device.

(6) Lead finish/Ball material - Orderable Devices may have multiple material finish options. Finish options are separated by a vertical ruled line. Lead finish/Ball material values may wrap to two lines if the finish value exceeds the maximum column width.

**Important Information and Disclaimer:** The information provided on this page represents TI's knowledge and belief as of the date that it is provided. TI bases its knowledge and belief on information provided by third parties, and makes no representation or warranty as to the accuracy of such information. Efforts are underway to better integrate information from third parties. TI has taken and continues to take reasonable steps to provide representative and accurate information but may not have conducted destructive testing or chemical analysis on incoming materials and chemicals. TI and TI suppliers consider certain information to be proprietary, and thus CAS numbers and other limited information may not be available for release.

In no event shall TI's liability arising out of such information exceed the total purchase price of the TI part(s) at issue in this document sold by TI to Customer on an annual basis.

**TAPE AND REEL INFORMATION**

**QUADRANT ASSIGNMENTS FOR PIN 1 ORIENTATION IN TAPE**

\*All dimensions are nominal

Device	Package Type	Package Drawing	Pins	SPQ	Reel Diameter (mm)	Reel Width W1 (mm)	A0 (mm)	B0 (mm)	K0 (mm)	P1 (mm)	W (mm)	Pin1 Quadrant
AMC1303E0510DWVR	SOIC	DWV	8	1000	330.0	16.4	12.05	6.15	3.3	16.0	16.0	Q1
AMC1303E0520DWVR	SOIC	DWV	8	1000	330.0	16.4	12.05	6.15	3.3	16.0	16.0	Q1
AMC1303E2510DWVR	SOIC	DWV	8	1000	330.0	16.4	12.05	6.15	3.3	16.0	16.0	Q1
AMC1303E2520DWVR	SOIC	DWV	8	1000	330.0	16.4	12.05	6.15	3.3	16.0	16.0	Q1
AMC1303M0510DWVR	SOIC	DWV	8	1000	330.0	16.4	12.05	6.15	3.3	16.0	16.0	Q1
AMC1303M0520DWVR	SOIC	DWV	8	1000	330.0	16.4	12.05	6.15	3.3	16.0	16.0	Q1
AMC1303M2510DWVR	SOIC	DWV	8	1000	330.0	16.4	12.05	6.15	3.3	16.0	16.0	Q1
AMC1303M2520DWVR	SOIC	DWV	8	1000	330.0	16.4	12.05	6.15	3.3	16.0	16.0	Q1
AMC1303M2520FDWVR	SOIC	DWV	8	1000	330.0	16.4	12.15	6.2	3.05	16.0	16.0	Q1

**TAPE AND REEL BOX DIMENSIONS**

\*All dimensions are nominal

Device	Package Type	Package Drawing	Pins	SPQ	Length (mm)	Width (mm)	Height (mm)
AMC1303E0510DWVR	SOIC	DWV	8	1000	350.0	350.0	43.0
AMC1303E0520DWVR	SOIC	DWV	8	1000	350.0	350.0	43.0
AMC1303E2510DWVR	SOIC	DWV	8	1000	350.0	350.0	43.0
AMC1303E2520DWVR	SOIC	DWV	8	1000	350.0	350.0	43.0
AMC1303M0510DWVR	SOIC	DWV	8	1000	350.0	350.0	43.0
AMC1303M0520DWVR	SOIC	DWV	8	1000	350.0	350.0	43.0
AMC1303M2510DWVR	SOIC	DWV	8	1000	350.0	350.0	43.0
AMC1303M2520DWVR	SOIC	DWV	8	1000	350.0	350.0	43.0
AMC1303M2520FDWVR	SOIC	DWV	8	1000	353.0	353.0	32.0

**TUBE**

\*All dimensions are nominal

Device	Package Name	Package Type	Pins	SPQ	L (mm)	W (mm)	T (μm)	B (mm)
AMC1303E0510DWV	DWV	SOIC	8	64	505.46	13.94	4826	6.6
AMC1303E0520DWV	DWV	SOIC	8	64	505.46	13.94	4826	6.6
AMC1303E2510DWV	DWV	SOIC	8	64	505.46	13.94	4826	6.6
AMC1303E2520DWV	DWV	SOIC	8	64	505.46	13.94	4826	6.6
AMC1303M0510DWV	DWV	SOIC	8	64	505.46	13.94	4826	6.6
AMC1303M0520DWV	DWV	SOIC	8	64	505.46	13.94	4826	6.6
AMC1303M2510DWV	DWV	SOIC	8	64	505.46	13.94	4826	6.6
AMC1303M2520DWV	DWV	SOIC	8	64	505.46	13.94	4826	6.6





DWV0008A

SOIC - 2.8 mm max height

SOIC

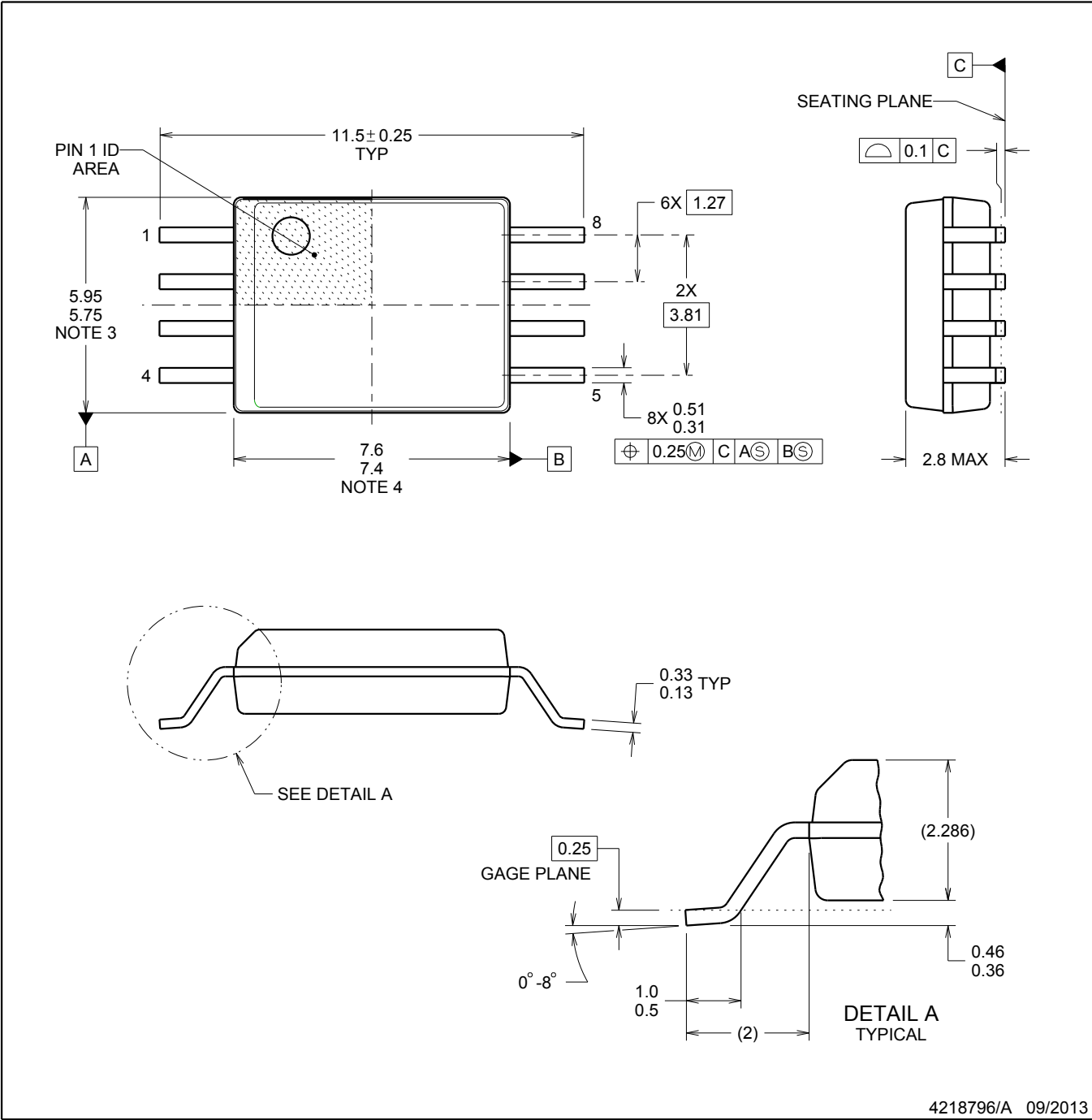

4218796/A 09/2013

NOTES:

- 1. All linear dimensions are in millimeters. Dimensions in parenthesis are for reference only. Dimensioning and tolerancing per ASME Y14.5M.
- 2. This drawing is subject to change without notice.
- 3. This dimension does not include mold flash, protrusions, or gate burrs. Mold flash, protrusions, or gate burrs shall not exceed 0.15 mm, per side.
- 4. This dimension does not include interlead flash. Interlead flash shall not exceed 0.25 mm, per side.



LAND PATTERN EXAMPLE  
9.1 mm NOMINAL CLEARANCE/CREEPAGE  
SCALE:6X

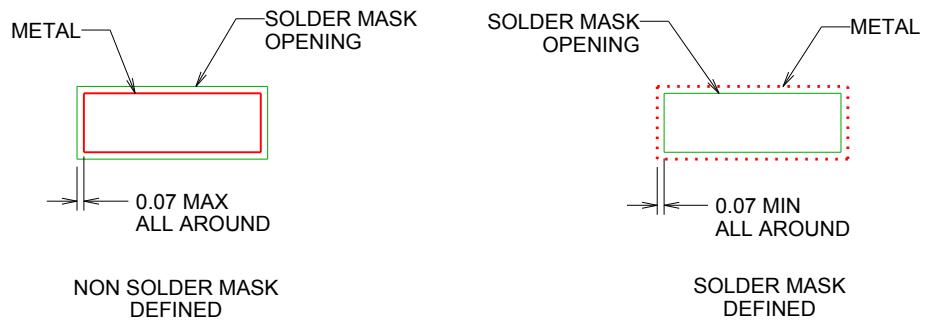

SOLDER MASK DETAILS

4218796/A 09/2013

NOTES: (continued)

- 5. Publication IPC-7351 may have alternate designs.
- 6. Solder mask tolerances between and around signal pads can vary based on board fabrication site.

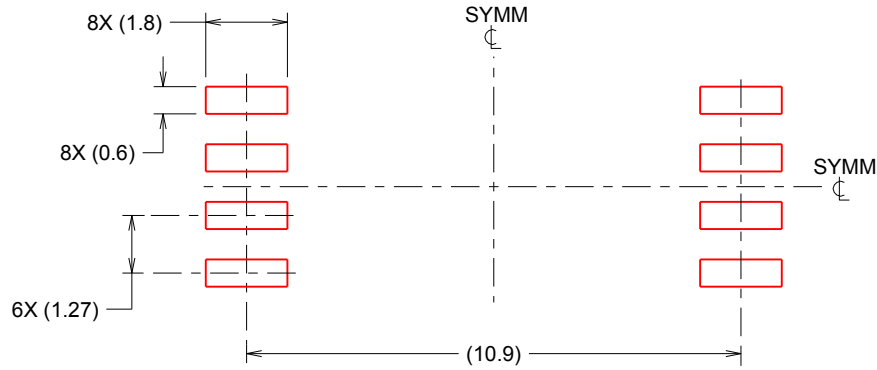

SOLDER PASTE EXAMPLE  
 BASED ON 0.125 mm THICK STENCIL  
 SCALE:6X

4218796/A 09/2013

NOTES: (continued)

- 7. Laser cutting apertures with trapezoidal walls and rounded corners may offer better paste release. IPC-7525 may have alternate design recommendations.
- 8. Board assembly site may have different recommendations for stencil design.

## IMPORTANT NOTICE AND DISCLAIMER

TI PROVIDES TECHNICAL AND RELIABILITY DATA (INCLUDING DATA SHEETS), DESIGN RESOURCES (INCLUDING REFERENCE DESIGNS), APPLICATION OR OTHER DESIGN ADVICE, WEB TOOLS, SAFETY INFORMATION, AND OTHER RESOURCES "AS IS" AND WITH ALL FAULTS, AND DISCLAIMS ALL WARRANTIES, EXPRESS AND IMPLIED, INCLUDING WITHOUT LIMITATION ANY IMPLIED WARRANTIES OF MERCHANTABILITY, FITNESS FOR A PARTICULAR PURPOSE OR NON-INFRINGEMENT OF THIRD PARTY INTELLECTUAL PROPERTY RIGHTS.

These resources are intended for skilled developers designing with TI products. You are solely responsible for (1) selecting the appropriate TI products for your application, (2) designing, validating and testing your application, and (3) ensuring your application meets applicable standards, and any other safety, security, regulatory or other requirements.

These resources are subject to change without notice. TI grants you permission to use these resources only for development of an application that uses the TI products described in the resource. Other reproduction and display of these resources is prohibited. No license is granted to any other TI intellectual property right or to any third party intellectual property right. TI disclaims responsibility for, and you will fully indemnify TI and its representatives against, any claims, damages, costs, losses, and liabilities arising out of your use of these resources.

TI's products are provided subject to [TI's Terms of Sale](#) or other applicable terms available either on [ti.com](#) or provided in conjunction with such TI products. TI's provision of these resources does not expand or otherwise alter TI's applicable warranties or warranty disclaimers for TI products.

TI objects to and rejects any additional or different terms you may have proposed.

Mailing Address: Texas Instruments, Post Office Box 655303, Dallas, Texas 75265

Copyright © 2025, Texas Instruments Incorporated