

## Lead-Acid Fast-Charge IC

### Features

- ▶ Conforms to battery manufacturers' charge recommendations for cyclic and float charge
- ▶ Pin-selectable charge algorithms
  - Two-Step Voltage with temperature-compensated constant-voltage maintenance
  - Two-Step Current with constant-rate pulsed current maintenance
  - Pulsed Current: hysteretic, on-demand pulsed current
- ▶ Pin-selectable charge termination by maximum voltage,  $\Delta^2V$ , minimum current, and maximum time
- ▶ Pre-charge qualification detects shorted, opened, or damaged cells and conditions battery
- ▶ Charging continuously qualified by temperature and voltage limits
- ▶ Internal temperature-compensated voltage reference
- ▶ Pulse-width modulation control

- Ideal for high-efficiency switch-mode power conversion
- Configurable for linear or gated current use
- ▶ Direct LED control outputs display charge status and fault conditions

### General Description

The bq2031 Lead-Acid Fast Charge IC is designed to optimize charging of lead-acid chemistry batteries. A flexible pulse-width modulation regulator allows the bq2031 to control constant-voltage, constant-current, or pulsed-current charging. The regulator frequency is set by an external capacitor for design flexibility. The switch-mode design keeps power dissipation to a minimum for high charge current applications.

A charge cycle begins when power is applied or the battery is replaced. For safety, charging is inhibited until the battery voltage is within configured limits. If the battery voltage is less than the low-voltage threshold, the bq2031 provides trickle-current

charging until the voltage rises into the allowed range or an internal timer runs out and places the bq2031 in a Fault condition. This procedure prevents high-current charging of cells that are possibly damaged or reversed. Charging is inhibited anytime the temperature of the battery is outside the configurable, allowed range. All voltage thresholds are temperature-compensated.

The bq2031 terminates fast (bulk) charging based on the following:

- Maximum voltage
- Second difference of cell voltage ( $\Delta^2V$ )
- Minimum current (in constant-voltage charging)
- Maximum time-out (MTO)

After bulk charging, the bq2031 provides temperature-compensated maintenance (float) charging to maintain battery capacity.

### Pin Connections

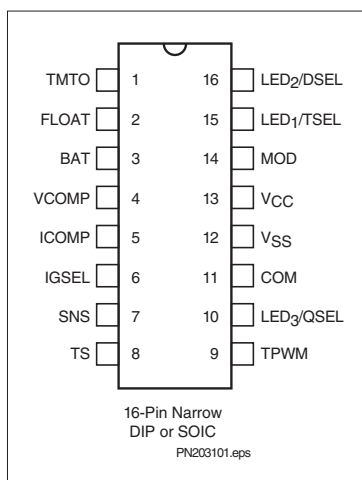

### Pin Names

TMTO	Time-out timebase input	LED <sub>3</sub> /QSEL	Charge status output 3/ Charge algorithm select input 1
FLOAT	State control output	COM	Common LED output
BAT	Battery voltage input	V <sub>SS</sub>	System ground
VCOMP	Voltage loop comp input	V <sub>CC</sub>	5.0V±10% power
ICOMP	Current loop comp input	MOD	Modulation control output
IGSEL	Current gain select input	LED <sub>1</sub> /TSEL	Charge status output 1/ Charge algorithm select input 2
SNS	Sense resistor input	LED <sub>2</sub> /DSEL	Charge status output 2/ Display select input
TS	Temperature sense input		
TPWM	Regulator timebase input		

# bq2031

---

## Pin Descriptions

<b>TMTO</b>	<b>Time-out timebase input</b>  This input sets the maximum charge time. The resistor and capacitor values are determined using equation 6. Figure 9 shows the resistor/capacitor connection.
<b>FLOAT</b>	<b>Float state control output</b>  This open-drain output uses an external resistor divider network to control the BAT input voltage threshold ( $V_{FLT}$ ) for the float charge regulation. See Figure 1.
<b>BAT</b>	<b>Battery voltage input</b>  BAT is the battery voltage sense input. This potential is generally developed using a high-impedance resistor divider network connected between the positive and the negative terminals of the battery. See Figure 6 and equation 2.
<b>VCOMP</b>	<b>Voltage loop compensation input</b>  This input uses an external C or R-C network for voltage loop stability.
<b>IGSEL</b>	<b>Current gain select input</b>  This three-state input is used to set $I_{MIN}$ for fast charge termination in the Two-Step Voltage algorithm and for maintenance current regulation in the Two-Step Current algorithm. See Tables 3 and 4.
<b>ICOMP</b>	<b>Current loop compensation input</b>  This input uses an external C or R-C network for current loop stability.
<b>SNS</b>	<b>Charging current sense input</b>  Battery current is sensed via the voltage developed on this pin by an external sense resistor, $R_{SNS}$ , connected in series with the low side of the battery. See equation 8.
<b>TS</b>	<b>Temperature sense input</b>  This input is for an external battery temperature monitoring thermistor or probe. An external resistor divider network sets the lower and upper temperature thresholds. See Figures 7 and 8 and equations 4 and 5.

<b>TPWM</b>	<b>Regulation timebase input</b>  This input uses an external timing capacitor to ground the pulse-width modulation (PWM) frequency. See equation 9.
<b>COM</b>	<b>Common LED output</b>  Common output for LED <sub>1-3</sub> . This output is in a high-impedance state during initialization to read program inputs on TSEL, QSEL, and DSEL.
<b>QSEL</b>	<b>Charge regulation select input</b>  With TSEL, selects the charge algorithm. See Table 1.
<b>MOD</b>	<b>Current-switching control output</b>  MOD is a pulse-width modulated push/pull output that is used to control the charging current to the battery. MOD switches high to enable current flow and low to inhibit current flow.
<b>LED<sub>1-3</sub></b>	<b>Charger display status 1–3 outputs</b>  These charger status output drivers are for the direct drive of the LED display. Display modes are shown in Table 2. These outputs are tri-stated during initialization so that QSEL, TSEL, and DSEL can be read.
<b>DSEL</b>	<b>Display select input</b>  This three-level input controls the LED <sub>1-3</sub> charge display modes. See Table 2.
<b>TSEL</b>	<b>Termination select input</b>  With QSEL, selects the charge algorithm. See Table 1.
<b>V<sub>CC</sub></b>	<b>V<sub>CC</sub> supply</b>  5.0V, ± 10% power
<b>V<sub>SS</sub></b>	<b>Ground</b>

## Functional Description

The bq2031 functional operation is described in terms of:

- Charge algorithms
- Charge qualification
- Charge status display
- Voltage and current monitoring
- Temperature monitoring

- Fast charge termination
- Maintenance charging
- Charge regulation

### Charge Algorithms

Three charge algorithms are available in the bq2031:

- Two-Step Voltage
- Two-Step Current
- Pulsed Current

The state transitions for these algorithms are described in Table 1 and are shown graphically in Figures 2 through 4. The user selects a charge algorithm by configuring pins QSEL and TSEL.

### Charge Qualification

The bq2031 starts a charge cycle when power is applied while a battery is present or when a battery is inserted. Figure 1 shows the state diagram for pre-charge qualification and temperature monitoring. The bq2031 first checks that the battery temperature is within the allowed, user-configurable range. If the temperature is out-of-range (or the thermistor is missing), the bq2031 enters the Charge Pending state and waits until the battery temperature is within the allowed range. Charge Pending is announced by LED<sub>3</sub> flashing.

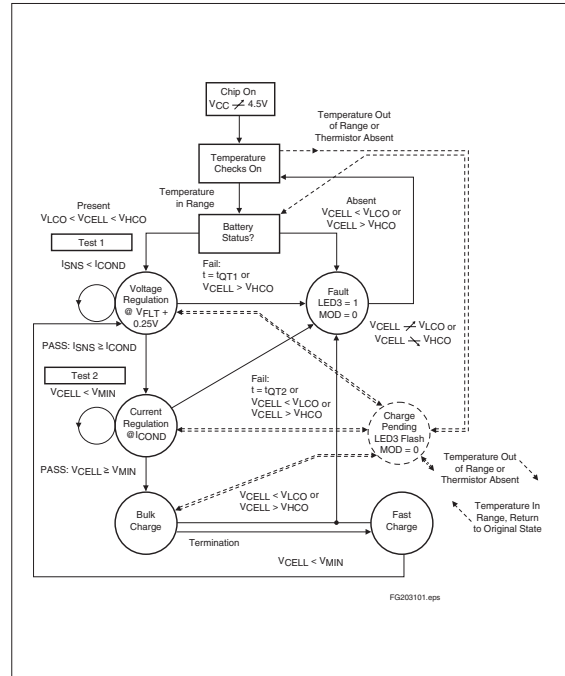

Figure 1. Cycle Start/Battery Qualification State Diagram

Table 1. bq2031 Charging Algorithms

Algorithm/State	QSEL	TSEL	Conditions	MOD Output
<b>Two-Step Voltage</b>	L	H/L <sup>Note 1</sup>	-	-
Fast charge, phase 1			while $V_{BAT} < V_{BLK}$ , $I_{SNS} = I_{MAX}$	Current regulation
Fast charge, phase 2			while $I_{SNS} > I_{MIN}$ , $V_{BAT} = V_{BLK}$	Voltage regulation
Primary termination			$I_{SNS} = I_{MIN}$	
Maintenance			$V_{BAT} = V_{FLT}$	Voltage regulation
<b>Two-Step Current</b>	H	L	-	-
Fast charge			while $V_{BAT} < V_{BLK}$ , $I_{SNS} = I_{MAX}$	Current regulation
Primary termination			$V_{BAT} = V_{BLK}$ or $\Delta^2V < -8mV$ <sup>Note 2</sup>	
Maintenance			$I_{SNS}$ pulsed to average $I_{FLT}$	Fixed pulse current
<b>Pulsed Current</b>	H	H	-	-
Fast charge			while $V_{BAT} < V_{BLK}$ , $I_{SNS} = I_{MAX}$	Current regulation
Primary termination			$V_{BAT} = V_{BLK}$	
Maintenance			$I_{SNS} = I_{MAX}$ after $V_{BAT} = V_{FLT}$ ; $I_{SNS} = 0$ after $V_{BAT} = V_{BLK}$	Hysteretic pulsed current

- Notes:**
1. May be high or low, but do not float.
  2. A Unitrode proprietary algorithm for accumulating successive differences between samples of  $V_{BAT}$ .

## bq2031

Thermal monitoring continues throughout the charge cycle, and the bq2031 enters the Charge Pending state anytime the temperature is out of range. (There is one exception; if the bq2031 is in the Fault state—see below—the out-of-range temperature is not recognized until the bq2031 leaves the Fault state.) All timers are suspended (but not reset) while the bq2031 is in Charge Pending. When the temperature comes back into range, the bq2031 returns to the point in the charge cycle where the out-of-range temperature was detected.

When the temperature is valid, the bq2031 performs two tests on the battery. In test 1, the bq2031 regulates a voltage of  $V_{FLT} + 0.25V$  across the battery and observes  $I_{SNS}$ . If  $I_{SNS}$  does not rise to at least  $I_{COND}$  within a time-out period (e.g., the cell has failed open), the bq2031 enters the Fault state. If test 1 passes, the bq2031 then regulates current to  $I_{COND}$  ( $= I_{MAX}/5$ ) and watches  $V_{CELL}$  ( $= V_{BAT} - V_{SNS}$ ). If  $V_{CELL}$  does not rise to at least  $V_{FLT}$  within a time-out period (e.g., the cell has failed short), again the bq2031 enters the Fault state. A hold-off period is enforced at the beginning of qualification

test 2 before the bq2031 recognizes its “pass” criterion. If this second test passes, the bq2031 begins fast (bulk) charging.

Once in the Fault state, the bq2031 waits until  $V_{CC}$  is cycled or a battery insertion is detected. It then starts a new charge cycle and begins the qualification process again.

### Charge Status Display

Charge status is announced by the LED driver outputs  $LED_1$ – $LED_3$ . Three display modes are available in the bq2031; the user selects a display mode by configuring pin DSEL. Table 2 shows the three modes and their programming pins.

The bq2031 does not distinguish between an over-voltage fault and a “battery absent” condition. The bq2031 enters the Fault state, announced by turning on  $LED_3$ , whenever the battery is absent. The bq2031, therefore, gives an indication that the charger is on even when no battery is in place to be charged.

**Table 2. bq2031 Display Output Summary**

Mode	Charge Action State	$LED_1$	$LED_2$	$LED_3$
DSEL = 0 (Mode 1)	Battery absent or over-voltage fault	Low	Low	High
	Pre-charge qualification	Flash	Low	Low
	Fast charging	High	Low	Low
	Maintenance charging	Low	High	Low
	Charge pending (temperature out of range)	X	X	Flash
	Charging fault	X	X	High
DSEL = 1 (Mode 2)	Battery absent or over-voltage fault	Low	Low	High
	Pre-charge qualification	High	High	Low
	Fast charge	Low	High	Low
	Maintenance charging	High	Low	Low
	Charge pending (temperature out of range)	X	X	Flash
	Charging fault	X	X	High
DSEL = Float (Mode 3)	Battery absent or over-voltage fault	Low	Low	High
	Pre-charge qualification	Flash	Flash	Low
	Fast charge: current regulation	Low	High	Low
	Fast charge: voltage regulation	High	High	Low
	Maintenance charging	High	Low	Low
	Charge pending (temperature out of range)	X	X	Flash
	Charging fault	X	X	High

**Notes:** 1 =  $V_{CC}$ ; 0 =  $V_{SS}$ ; X = LED state when fault occurred; Flash =  $\frac{1}{6}$  s low,  $\frac{1}{6}$  s high.

In the Pulsed Current algorithm, the bq2031 announces maintenance when charging current is off and fast charge whenever charging current is on.

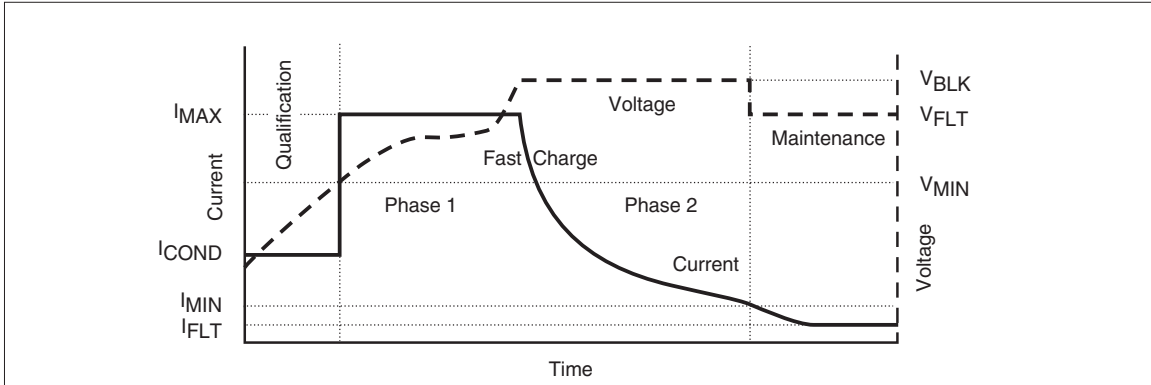

Figure 2. Two-Step Voltage Algorithm

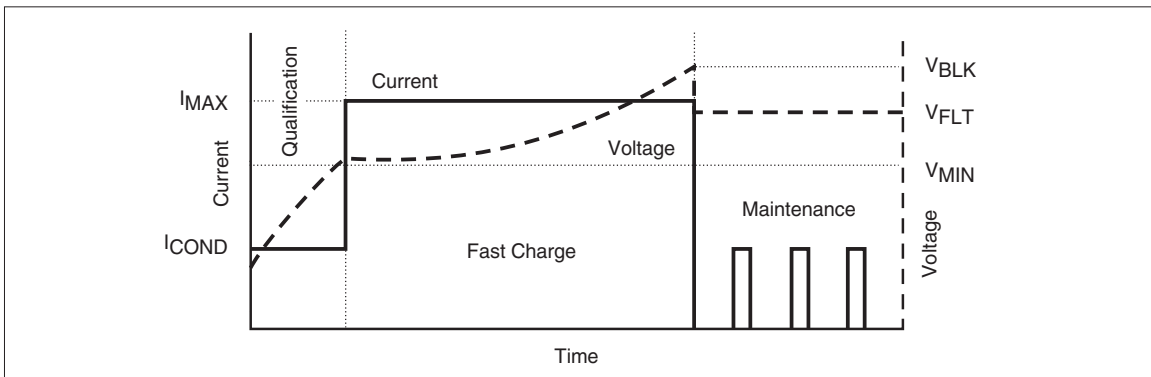

Figure 3. Two-Step Current Algorithm

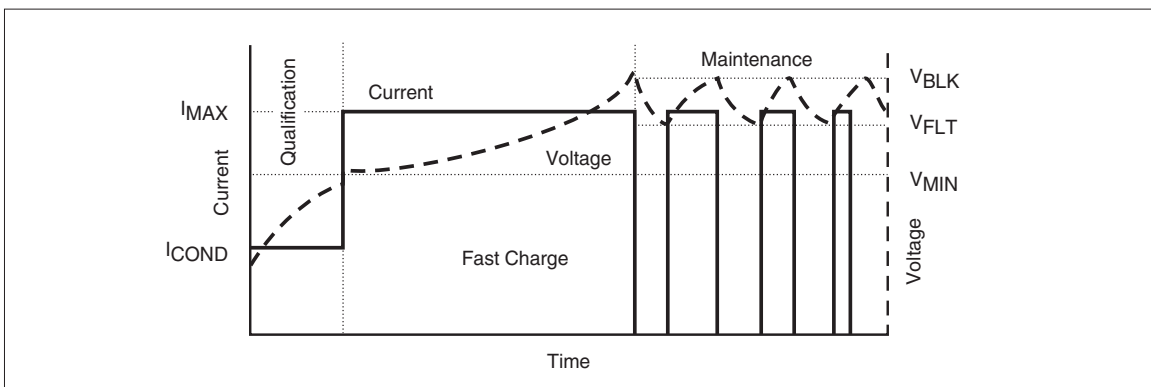

Figure 4. Pulsed Current Algorithm

# bq2031

## Configuring Algorithm and Display Modes

QSEL/LED<sub>3</sub>, DSEL/LED<sub>2</sub>, and TSEL/LED<sub>1</sub> are bi-directional pins with two functions; they are LED driver pins as outputs and programming pins for the bq2031 as inputs. The selection of pull-up, pull-down, or no pull resistor programs the charging algorithm on QSEL and TSEL per Table 1 and the display mode on DSEL per Table 2. The bq2031 latches the program states when any of the following events occurs:

1. VCC rises to a valid level.
2. The bq2031 leaves the Fault state.
3. The bq2031 detects battery insertion.

The LEDs go blank for approximately 750ms (typical) while new programming data is latched.

For example, Figure 5 shows the bq2031 configured for the Pulsed Current algorithm and display mode 2.

## Voltage and Current Monitoring

The bq2031 monitors battery pack voltage at the BAT pin. A voltage divider between the positive and negative terminals of the battery pack is used to present a scaled battery pack voltage to the BAT pin and an appropriate value for regulation of float (maintenance) voltage to the FLOAT pin. The bq2031 also uses the voltage across a

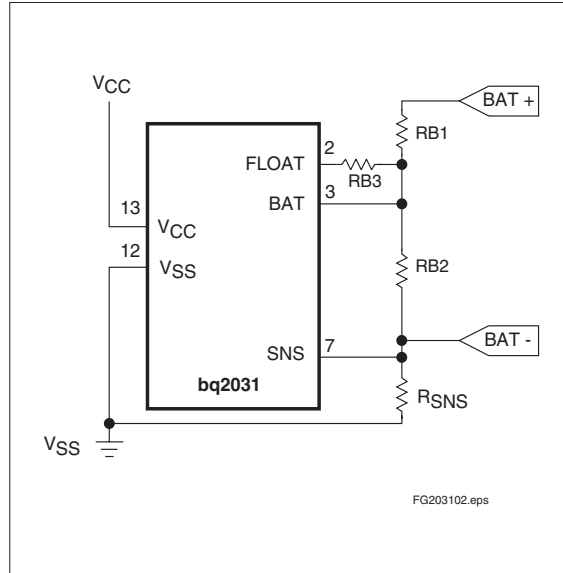

Figure 6. Configuring the Battery Divider

sense resistor ( $R_{SNS}$ ) between the negative terminal of the battery pack and ground to monitor current. See Figure 6 for the configuration of this network.

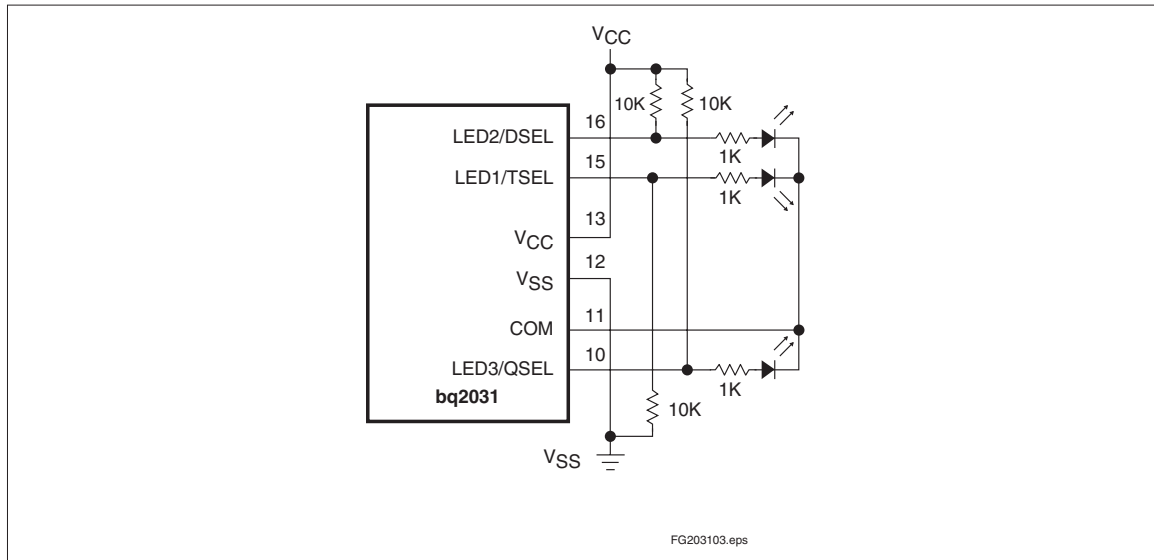

Figure 5. Configuring Charging Algorithm and Display Mode

The resistor values are calculated from the following:

Equation 1

$$\frac{RB1}{RB2} = \frac{(N * V_{FLT})}{2.2V} - 1$$

Equation 2

$$\frac{RB1}{RB2} + \frac{RB1}{RB3} = \left( \frac{N * V_{BLK}}{2.2} \right) - 1$$

Equation 3

$$I_{MAX} = \frac{0.250V}{R_{SNS}}$$

where:

- N = Number of cells
- V<sub>FLT</sub> = Desired float voltage
- V<sub>BLK</sub> = Desired bulk charging voltage
- I<sub>MAX</sub> = Desired maximum charge current

These parameters are typically specified by the battery manufacturer. The total resistance presented across the battery pack by RB1 + RB2 should be between 150kΩ and 1MΩ. The minimum value ensures that the divider network does not drain the battery excessively when the power source is disconnected. Exceeding the maximum value increases the noise susceptibility of the BAT pin.

An empirical procedure for setting the values in the resistor network is as follows:

1. Set RB2 to 49.9 kΩ. (for 3 to 18 series cells)
2. Determine RB1 from equation 1 given V<sub>FLT</sub>
3. Determine RB3 from equation 2 given V<sub>BLK</sub>
4. Calculate R<sub>SNS</sub> from equation 3 given I<sub>MAX</sub>

### Battery Insertion and Removal

The bq2031 uses V<sub>BAT</sub> to detect the presence or absence of a battery. The bq2031 determines that a battery is present when V<sub>BAT</sub> is between the High-Voltage Cutoff (V<sub>HCO</sub> = 0.6 \* V<sub>CC</sub>) and the Low-Voltage Cutoff (V<sub>LCO</sub> = 0.8V). When V<sub>BAT</sub> is outside this range, the bq2031 determines that no battery is present and transitions to the Fault state. Transitions into and out of the range between V<sub>LCO</sub> and V<sub>HCO</sub> are treated as battery insertions and removals, respectively. Besides being used to detect battery insertion, the V<sub>HCO</sub> limit implicitly serves as an over-voltage charge termination, because exceeding this limit causes the bq2031 to believe that the battery has been removed.

The user must include a pull-up resistor from the positive terminal of the battery stack to VDC (and a diode to prevent battery discharge through the power supply when the supply is turned off) in order to detect battery removal during periods of voltage regulation. Voltage regulation occurs in pre-charge qualification test 1 prior to all of the fast charge algorithms, and in phase 2 of the Two-Step Voltage fast charge algorithm.

### Temperature Monitoring

The bq2031 monitors temperature by examining the voltage presented between the TS and SNS pins (V<sub>TEMP</sub>) by a resistor network that includes a Negative Temperature Coefficient (NTC) thermistor. Resistance variations around that value are interpreted as being proportional to the battery temperature (see Figure 7).

The temperature thresholds used by the bq2031 and their corresponding TS pin voltage are:

- TCO—Temperature cutoff—Higher limit of the temperature range in which charging is allowed. V<sub>TCO</sub> = 0.4 \* V<sub>CC</sub>
- HTF—High-temperature fault—Threshold to which temperature must drop after temperature cutoff is exceeded before charging can begin again. V<sub>HTF</sub> = 0.44 \* V<sub>CC</sub>

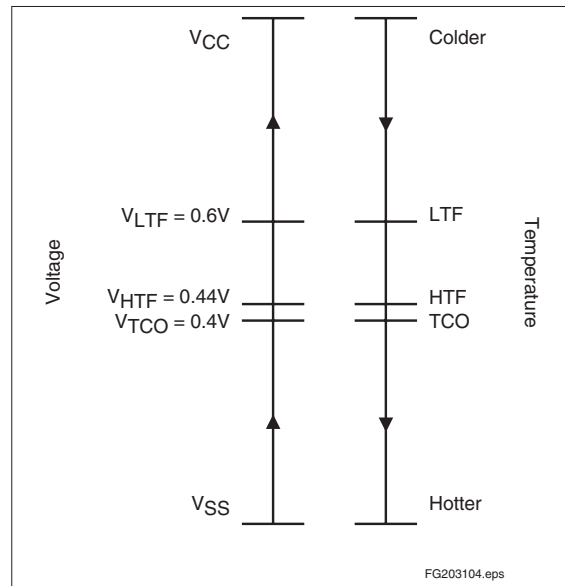

Figure 7. Voltage Equivalent of Temperature Thresholds

## bq2031

- LTF—Low-temperature fault—Lower limit of the temperature range in which charging is allowed.  $V_{LTF} = 0.6 * V_{CC}$

A resistor-divider network must be implemented that presents the defined voltage levels to the TS pin at the desired temperatures (see Figure 8).

The equations for determining RT1 and RT2 are:

Equation 4

$$0.6 * V_{CC} = \frac{(V_{CC} - 0.250V)}{1 + \frac{RT1 * (RT2 + R_{LTF})}{(RT2 * R_{LTF})}}$$

Equation 5

$$0.44 = \frac{1}{1 + \frac{RT1 * (RT2 + R_{HTF})}{(RT2 * R_{HTF})}}$$

where:

- $R_{LTF}$  = thermistor resistance at LTF
- $R_{HTF}$  = thermistor resistance at HTF

TCO is determined by the values of RT1 and RT2. 1% resistors are recommended.

### Disabling Temperature Sensing

Temperature sensing can be disabled by removing RT and using a 100kΩ resistor for RT1 and RT2.

### Temperature Compensation

The internal voltage reference used by the bq2031 for all voltage threshold determinations is compensated for temperature. The temperature coefficient is -3.9mV/°C, normalized to 25°C. Voltage thresholds in the bq2031 vary by this proportion as ambient conditions change.

### Fast-Charge Termination

Fast-charge termination criteria are programmed with the fast charge algorithm per Table 1. Note that not all criteria are applied in all algorithms.

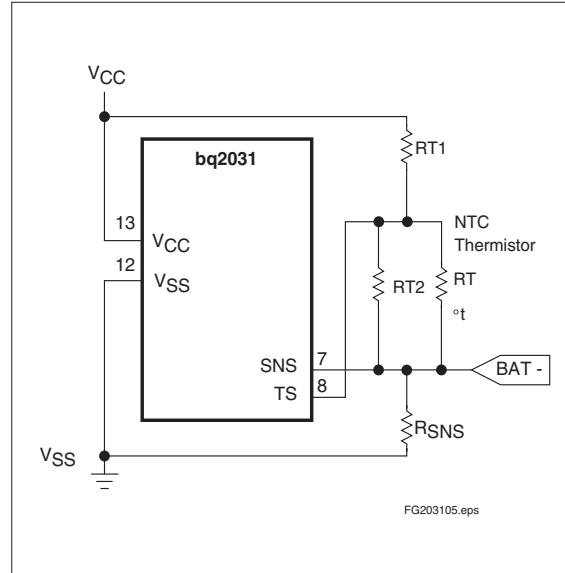

**Figure 8. Configuring Temperature Sensing**

### Minimum Current

Fast charge terminates when the charging current drops below a minimum current threshold programmed by the value of IGSEL (see Table 3). This is used by the Two-Step Voltage algorithm.

**Table 3. I<sub>MIN</sub> Termination Thresholds**

IGSEL	I <sub>MIN</sub>
0	I <sub>MAX</sub> /10
1	I <sub>MAX</sub> /20
Z	I <sub>MAX</sub> /30



## Second Difference ( $\Delta^2V$ )

Second difference is a Unitrode proprietary algorithm that accumulates the difference between successive samples of  $V_{BAT}$ . The bq2031 takes a sample and makes a termination decision at a frequency equal to  $0.008 * t_{MTO}$ . Fast charge terminates when the accumulated difference is  $\leq -8mV$ . Second difference is used only in the Two-Step Current algorithm, and is subject to a hold-off period (see below).

## Maximum Voltage

Fast charge terminates when  $V_{CELL} \geq V_{BLK}$ .  $V_{BLK}$  is set per equation 2. Maximum voltage is used for fast charge termination in the Two-Step Current and Pulsed Current algorithms, and for transition from phase 1 to phase 2 in the Two-Step Voltage algorithm. This criterion is subject to a hold-off period.

## Hold-off Periods

Maximum V and  $\Delta^2V$  termination criteria are subject to a hold-off period at the start of fast charge equal to  $0.15 * t_{MTO}$ . During this time, these termination criteria are ignored.

## Maximum Time-Out

Fast charge terminates if the programmed MTO time is reached without some other termination shutting off fast charge. MTO is programmed from 1 to 24 hours by an R-C network on TMTO (see Figure 9) per the equation:

Equation 6

$$t_{MTO} = 0.5 * R * C$$

where R is in k $\Omega$ , C is in  $\mu F$ , and  $t_{MTO}$  is in hours. Typically, the maximum value for C of 0.1 $\mu F$  is used.

Fast-charge termination by MTO is a Fault only in the Pulsed Current algorithm; the bq2031 enters the Fault state and waits for a new battery insertion, at which time it begins a new charge cycle. In the Two-Step Voltage and Two-Step Current algorithms, the bq2031 transitions to the maintenance phase on MTO time-out.

The MTO timer starts at the beginning of fast charge. In the Two-Step Voltage algorithm, it is cleared and restarted when the bq2031 transitions from phase 1 (current regulation) to phase 2 (voltage regulation). The MTO timer is suspended (but not reset) during the out-of-range temperature (Charge Pending) state.

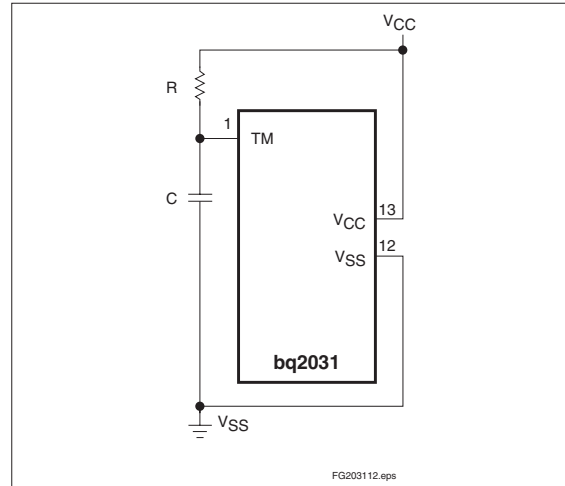

Figure 9. R-C Network for Setting MTO

## Maintenance Charging

Three algorithms are used in maintenance charging:

- Two-Step Voltage algorithm
- Two-Step Current algorithm
- Pulsed Current algorithm

### Two-Step Voltage Algorithm

In the Two-Step Voltage algorithm, the bq2031 provides charge maintenance by regulating charging voltage to  $V_{FLT}$ . Charge current during maintenance is limited to  $I_{COND}$ .

### Two-Step Current Algorithm

Maintenance charging in the Two-Step Current Algorithm is implemented by varying the period ( $T_P$ ) of a fixed current ( $I_{COND} = I_{MAX}/5$ ) and duration (0.2 seconds) pulse to achieve the configured average maintenance current value. See Figure 10.

Maintenance current can be calculated by:

Equation 7

$$\text{Maintenance current} = \frac{((0.2) * I_{COND})}{T_P} = \frac{((0.04) * I_{MAX})}{T_P}$$

where  $T_P$  is the period of the waveform in seconds.

Table 4 gives the values of P programmed by IGSEL.

# bq2031

**Table 4. Fixed-Pulse Period by IGSEL**

IGSEL	T <sub>P</sub> (sec.)
L	0.4
H	0.8
Z	1.6

## Pulsed Current Algorithm

In the Pulsed Current algorithm, charging current is turned off after the initial fast charge termination until V<sub>CELL</sub> falls to V<sub>FLT</sub>. Full fast charge current (I<sub>MAX</sub>) is then re-enabled to the battery until V<sub>CELL</sub> rises to V<sub>BLK</sub>. This cycle repeats indefinitely.

## Charge Regulation

The bq2031 controls charging through pulse-width modulation of the MOD output pin, supporting both constant-current and constant-voltage regulation. Charge current is monitored by the voltage at the SNS pin, and charge voltage by voltage at the BAT pin. These voltages are compared to an internal temperature-compensated reference, and the MOD output modulated to maintain the desired value.

Voltage at the SNS pin is determined by the value of resistor R<sub>SNS</sub>, so nominal regulated current is set by:

Equation 8

$$I_{MAX} = 0.250V/R_{SNS}$$

The switching frequency of the MOD output is determined by an external capacitor (C<sub>PWM</sub>) between the pin TPWM and ground, per the following:

Equation 9

$$F_{PWM} = 0.1/C_{PWM}$$

where C is in μF and F is in kHz. A typical switching rate is 100kHz, implying C<sub>PWM</sub> = 0.001μF. MOD pulse width is modulated between 0 and 80% of the switching period.

To prevent oscillation in the voltage and current control loops, frequency compensation networks (C or R-C) are typically required on the VCOMP and ICOMP pins (respectively) to add poles and zeros to the loop control equations. A software program, “CNFG2031,” is available to assist in configuring these networks for buck type regulators. For more detail on the control loops in buck topology, see the application note, “Switch-Mode Power Conversion Using the bq2031.” For assistance with other power supply topologies, contact the factory.

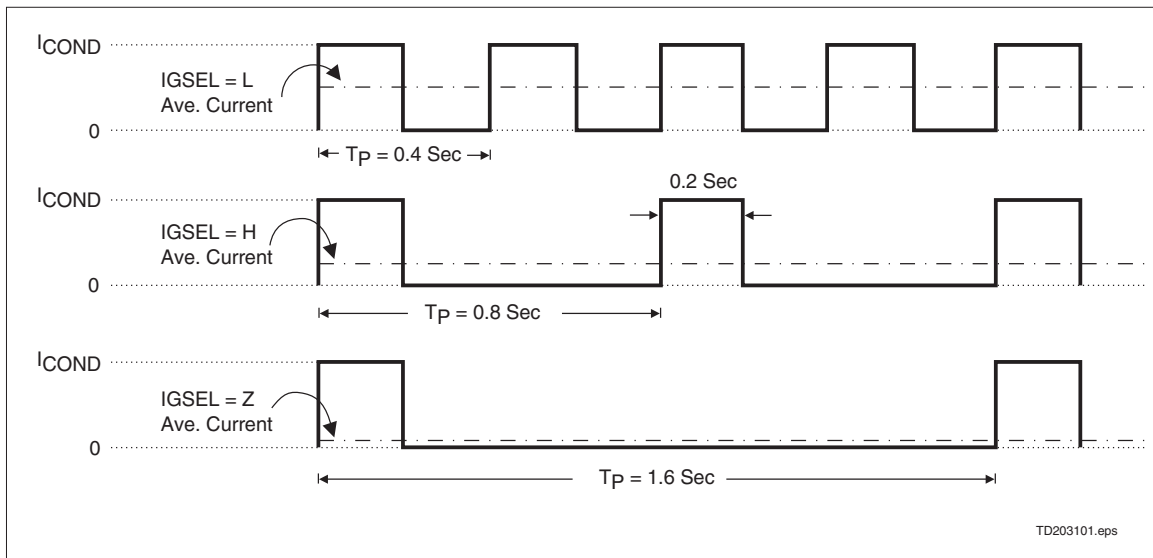

**Figure 10. Implementation of Fixed-Pulse Maintenance Charge**

## Absolute Maximum Ratings

Symbol	Parameter	Minimum	Maximum	Unit	Notes
V <sub>CC</sub>	V <sub>CC</sub> relative to V <sub>SS</sub>	-0.3	+7.0	V	
V <sub>T</sub>	DC voltage applied on any pin excluding V <sub>CC</sub> relative to V <sub>SS</sub>	-0.3	+7.0	V	
T <sub>OPR</sub>	Operating ambient temperature	-20	+70	°C	Commercial
T <sub>STG</sub>	Storage temperature	-55	+125	°C	
T <sub>SOLDER</sub>	Soldering temperature	-	+260	°C	10 s. max.
T <sub>BIAS</sub>	Temperature under bias	-40	+85	°C	

Note: Permanent device damage may occur if **Absolute Maximum Ratings** are exceeded. Functional operation should be limited to the Recommended DC Operating Conditions detailed in this data sheet. Exposure to conditions beyond the operational limits for extended periods of time may affect device reliability.

## DC Thresholds (T<sub>A</sub> = T<sub>OPR</sub>; V<sub>CC</sub> = 5V ±10%)

Symbol	Parameter	Rating	Unit	Tolerance	Notes
V <sub>REF</sub>	Internal reference voltage	2.20	V	1%	T <sub>A</sub> = 25°C
	Temperature coefficient	-3.9	mV/°C	10%	
V <sub>LTF</sub>	TS maximum threshold	0.6 * V <sub>CC</sub>	V	±0.03V	Low-temperature fault
V <sub>HTF</sub>	TS hysteresis threshold	0.44 * V <sub>CC</sub>	V	±0.03V	High-temperature fault
V <sub>TCO</sub>	TS minimum threshold	0.4 * V <sub>CC</sub>	V	±0.03V	Temperature cutoff
V <sub>HCO</sub>	High cutoff voltage	0.60 * V <sub>CC</sub>	V	±0.03V	
V <sub>MIN</sub>	Under-voltage threshold at BAT	0.34 * V <sub>CC</sub>	V	±0.03V	
V <sub>LCO</sub>	Low cutoff voltage	0.8	V	±0.03V	
V <sub>SNS</sub>	Current sense at SNS	0.250	V	10%	I <sub>MAX</sub>
		0.05	V	10%	I <sub>COND</sub>

# bq2031

## Recommended DC Operating Conditions (TA = TOPR)

Symbol	Parameter	Minimum	Typical	Maximum	Unit	Notes
V <sub>CC</sub>	Supply voltage	4.5	5.0	5.5	V	
V <sub>TEMP</sub>	TS voltage potential	0	-	V <sub>CC</sub>	V	V <sub>TS</sub> - V <sub>SNS</sub>
V <sub>CELL</sub>	Battery voltage potential	0	-	V <sub>CC</sub>	V	V <sub>BAT</sub> - V <sub>SNS</sub>
I <sub>CC</sub>	Supply current	-	2	4	mA	Outputs unloaded
I <sub>IZ</sub>	DSEL tri-state open detection	-2	-	2	μA	Note 2
	IGSEL tri-state open detection	-2	-	2	μA	
V <sub>IH</sub>	Logic input high	V <sub>CC</sub> -1.0	-	-	V	QSEL, TSEL
		V <sub>CC</sub> -0.3	-	-	V	DSEL, IGSEL
V <sub>IL</sub>	Logic input low	-	-	V <sub>SS</sub> +1.0	V	QSEL, TSEL
		-	-	V <sub>SS</sub> +0.3	V	DSEL, IGSEL
V <sub>OH</sub>	LED <sub>1</sub> , LED <sub>2</sub> , LED <sub>3</sub> , output high	V <sub>CC</sub> -0.8	-	-	V	I <sub>OH</sub> ≤ 10mA
	MOD output high	V <sub>CC</sub> -0.8	-	-	V	I <sub>OH</sub> ≤ 10mA
V <sub>OL</sub>	LED <sub>1</sub> , LED <sub>2</sub> , LED <sub>3</sub> , output low	-	-	V <sub>SS</sub> +0.8V	V	I <sub>OL</sub> ≤ 10mA
	MOD output low	-	-	V <sub>SS</sub> +0.8V	V	I <sub>OL</sub> ≤ 10mA
	FLOAT output low	-	-	V <sub>SS</sub> +0.8V	V	I <sub>OL</sub> ≤ 5mA, Note 3
	COM output low	-	-	V <sub>SS</sub> +0.5	V	I <sub>OL</sub> ≤ 30mA
I <sub>OH</sub>	LED <sub>1</sub> , LED <sub>2</sub> , LED <sub>3</sub> , source	-10	-	-	mA	V <sub>OH</sub> = V <sub>CC</sub> -0.5V
	MOD source	-5.0	-	-	mA	V <sub>OH</sub> = V <sub>CC</sub> -0.5V
I <sub>OL</sub>	LED <sub>1</sub> , LED <sub>2</sub> , LED <sub>3</sub> , sink	10	-	-	mA	V <sub>OL</sub> = V <sub>SS</sub> +0.5V
	MOD sink	5	-	-	mA	V <sub>OL</sub> = V <sub>SS</sub> +0.8V
	FLOAT sink	5	-	-	mA	V <sub>OL</sub> = V <sub>SS</sub> +0.8V, Note 3
	COM sink	30	-	-	mA	V <sub>OL</sub> = V <sub>SS</sub> +0.5V
I <sub>IL</sub>	DSEL logic input low source	-	-	+30	μA	V = V <sub>SS</sub> to V <sub>SS</sub> + 0.3V, Note 2
	IGSEL logic input low source	-	-	+70	μA	V = V <sub>SS</sub> to V <sub>SS</sub> + 0.3V
I <sub>IH</sub>	DSEL logic input high source	-30	-	-	μA	V = V <sub>CC</sub> - 0.3V to V <sub>CC</sub>
	IGSEL logic input high source	-70	-	-	μA	V = V <sub>CC</sub> - 0.3V to V <sub>CC</sub>
I <sub>L</sub>	Input leakage	-	-	±1	μA	QSEL, TSEL, Note 2

- Notes:**
1. All voltages relative to V<sub>SS</sub> except where noted.
  2. Conditions during initialization after V<sub>CC</sub> applied.
  3. SNS = 0V.

## Impedance

Symbol	Parameter	Minimum	Typical	Maximum	Unit	Notes
R <sub>BATZ</sub>	BAT pin input impedance	50	-	-	MΩ	
R <sub>SNSZ</sub>	SNS pin input impedance	50	-	-	MΩ	
R <sub>TSZ</sub>	TS pin input impedance	50	-	-	MΩ	
R <sub>PROG1</sub>	Soft-programmed pull-up or pull-down resistor value (for programming)	-	-	10	kΩ	DSEL, TSEL, and QSEL
R <sub>PROG2</sub>	Pull-up or pull-down resistor value	-	-	3	kΩ	IGSEL
R <sub>MTO</sub>	Charge timer resistor	20	-	480	kΩ	

## Timing (T<sub>A</sub> = T<sub>OPR</sub>; V<sub>CC</sub> = 5V ±10%)

Symbol	Parameter	Minimum	Typical	Maximum	Unit	Notes
t <sub>MTO</sub>	Charge time-out range	1	-	24	hours	See Figure 9
t <sub>QT1</sub>	Pre-charge qual test 1 time-out period	-	0.02t <sub>MTO</sub>	-	-	
t <sub>QT2</sub>	Pre-charge qual test 2 time-out period	-	0.16t <sub>MTO</sub>	-	-	
t <sub>DV</sub>	Δ <sup>2</sup> V termination sample frequency	-	0.008t <sub>MTO</sub>	-	-	
t <sub>H01</sub>	Pre-charge qual test 2 hold-off period	-	0.002t <sub>MTO</sub>	-	-	
t <sub>H02</sub>	Bulk charge hold-off period	-	0.015t <sub>MTO</sub>	-	-	
F <sub>PWM</sub>	PWM regulator frequency range	-	100		kHz	See Equation 9

## Capacitance

Symbol	Parameter	Minimum	Typical	Maximum	Unit
C <sub>MTO</sub>	Charge timer capacitor	-	0.1	0.1	μF
C <sub>PWM</sub>	PWM R-C capacitance	-	0.001	-	μF

# bq2031

## 16-Pin DIP Narrow (PN)

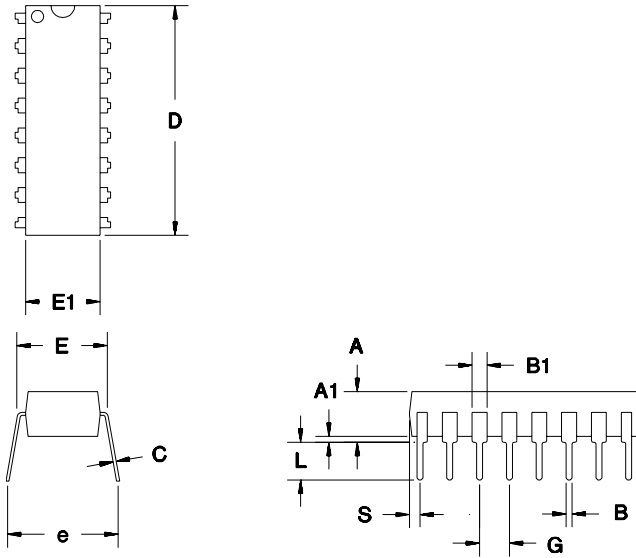

### 16-Pin PN (0.300" DIP)

Dimension	Inches		Millimeters	
	Min.	Max.	Min.	Max.
A	0.160	0.180	4.06	4.57
A1	0.015	0.040	0.38	1.02
B	0.015	0.022	0.38	0.56
B1	0.055	0.065	1.40	1.65
C	0.008	0.013	0.20	0.33
D	0.740	0.770	18.80	19.56
E	0.300	0.325	7.62	8.26
E1	0.230	0.280	5.84	7.11
e	0.300	0.370	7.62	9.40
G	0.090	0.110	2.29	2.79
L	0.115	0.150	2.92	3.81
S	0.020	0.040	0.51	1.02

## 16-Pin SOIC Narrow (SN)

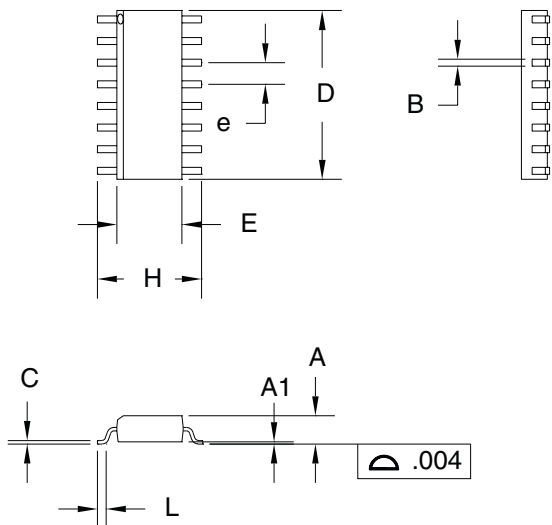

### 16-Pin SN (0.150" SOIC)

Dimension	Inches		Millimeters	
	Min.	Max.	Min.	Max.
A	0.060	0.070	1.52	1.78
A1	0.004	0.010	0.10	0.25
B	0.013	0.020	0.33	0.51
C	0.007	0.010	0.18	0.25
D	0.385	0.400	9.78	10.16
E	0.150	0.160	3.81	4.06
e	0.045	0.055	1.14	1.40
H	0.225	0.245	5.72	6.22
L	0.015	0.035	0.38	0.89

## Data Sheet Revision History

Change No.	Page No.	Description	Nature of Change
1		Descriptions	Clarified and consolidated
1		Renamed	Dual-Level Constant Current Mode to Two-Step Current Mode V <sub>MCV</sub> to V <sub>HCO</sub> V <sub>INT</sub> to V <sub>LCO</sub> t <sub>UV1</sub> to t <sub>QT1</sub> t <sub>UV2</sub> to t <sub>QT2</sub>
1		Consolidation	Tables 1 and 2
1		Added figures	Start-up states Temperature sense input voltage thresholds Pulsed maintenance current implementation
1		Updated figures	Figures 1 through 6
1		Added equations	Thermistor divider network configuration equations
1		Raised condition	MOD V <sub>OL</sub> and V <sub>OH</sub> parameters from ≤5mA to ≤10μA
1		Corrected Conditions	VSNS rating from V <sub>MAX</sub> and V <sub>MIN</sub> to I <sub>MAX</sub> and I <sub>MIN</sub>
1		Added table	Capacitance table for C <sub>MTO</sub> and C <sub>PWM</sub>
2	6	Changed values in Figure 5	Was 51K; is now 10K
3	7, 10	Changed values in Equations 3 and 8	Was: I <sub>MAX</sub> = 0.275V/R <sub>SNS</sub> ; is now I <sub>MAX</sub> = 0.250V/R <sub>SNS</sub>
3	8	Changed values in Equation 4	Was: (V <sub>CC</sub> - 0.275); is now (V <sub>CC</sub> - 0.250V)
3	11	Changed rating value for V <sub>SNS</sub> in DC Thresholds table	Was 0.275; is now 0.250
4	11	T <sub>OPR</sub>	Deleted industrial temperature range.

**Notes:** Change 1 = Dec. 1995 B changes from June 1995 A.  
Change 2 = Sept. 1996 C changes from Dec. 1995 B.  
Change 3 = April 1997 D changes from Sept. 1996 C.  
Change 4 = June 1999 E changes from April 1997 D.

## Ordering Information

**bq2031**

Package Option:

PN = 16-pin plastic DIP

SN = 16-pin narrow SOIC

Device:

bq2031 Lead Acid Charge IC

## PACKAGING INFORMATION

Orderable part number	Status (1)	Material type (2)	Package   Pins	Package qty   Carrier	RoHS (3)	Lead finish/ Ball material (4)	MSL rating/ Peak reflow (5)	Op temp (°C)	Part marking (6)
<a href="#">BQ2031PN-A5</a>	Active	Production	PDIP (N)   16	25   TUBE	Yes	NIPDAU	N/A for Pkg Type	-20 to 70	2031PN-A5
<a href="#">BQ2031SN-A5</a>	Active	Production	SOIC (D)   16	40   TUBE	Yes	NIPDAU	Level-1-260C-UNLIM	-20 to 70	2031 (-A5, A5)
<a href="#">BQ2031SN-A5TR</a>	Active	Production	SOIC (D)   16	2500   LARGE T&R	Yes	NIPDAU	Level-1-260C-UNLIM	-20 to 70	2031 (-A5, A5)

(1) **Status:** For more details on status, see our [product life cycle](#).

(2) **Material type:** When designated, preproduction parts are prototypes/experimental devices, and are not yet approved or released for full production. Testing and final process, including without limitation quality assurance, reliability performance testing, and/or process qualification, may not yet be complete, and this item is subject to further changes or possible discontinuation. If available for ordering, purchases will be subject to an additional waiver at checkout, and are intended for early internal evaluation purposes only. These items are sold without warranties of any kind.

(3) **RoHS values:** Yes, No, RoHS Exempt. See the [TI RoHS Statement](#) for additional information and value definition.

(4) **Lead finish/Ball material:** Parts may have multiple material finish options. Finish options are separated by a vertical ruled line. Lead finish/Ball material values may wrap to two lines if the finish value exceeds the maximum column width.

(5) **MSL rating/Peak reflow:** The moisture sensitivity level ratings and peak solder (reflow) temperatures. In the event that a part has multiple moisture sensitivity ratings, only the lowest level per JEDEC standards is shown. Refer to the shipping label for the actual reflow temperature that will be used to mount the part to the printed circuit board.

(6) **Part marking:** There may be an additional marking, which relates to the logo, the lot trace code information, or the environmental category of the part.

Multiple part markings will be inside parentheses. Only one part marking contained in parentheses and separated by a "-" will appear on a part. If a line is indented then it is a continuation of the previous line and the two combined represent the entire part marking for that device.

**Important Information and Disclaimer:**The information provided on this page represents TI's knowledge and belief as of the date that it is provided. TI bases its knowledge and belief on information provided by third parties, and makes no representation or warranty as to the accuracy of such information. Efforts are underway to better integrate information from third parties. TI has taken and continues to take reasonable steps to provide representative and accurate information but may not have conducted destructive testing or chemical analysis on incoming materials and chemicals. TI and TI suppliers consider certain information to be proprietary, and thus CAS numbers and other limited information may not be available for release.

In no event shall TI's liability arising out of such information exceed the total purchase price of the TI part(s) at issue in this document sold by TI to Customer on an annual basis.



**TAPE AND REEL INFORMATION**

**QUADRANT ASSIGNMENTS FOR PIN 1 ORIENTATION IN TAPE**

\*All dimensions are nominal

Device	Package Type	Package Drawing	Pins	SPQ	Reel Diameter (mm)	Reel Width W1 (mm)	A0 (mm)	B0 (mm)	K0 (mm)	P1 (mm)	W (mm)	Pin1 Quadrant
BQ2031SN-A5TR	SOIC	D	16	2500	330.0	16.4	6.5	10.3	2.1	8.0	16.0	Q1

**TAPE AND REEL BOX DIMENSIONS**

\*All dimensions are nominal

Device	Package Type	Package Drawing	Pins	SPQ	Length (mm)	Width (mm)	Height (mm)
BQ2031SN-A5TR	SOIC	D	16	2500	356.0	356.0	35.0

**TUBE**

\*All dimensions are nominal

Device	Package Name	Package Type	Pins	SPQ	L (mm)	W (mm)	T (μm)	B (mm)
BQ2031PN-A5	N	PDIP	16	25	506	13.97	11230	4.32
BQ2031PN-A5.Z	N	PDIP	16	25	506	13.97	11230	4.32
BQ2031PN-A5E4	N	PDIP	16	25	506	13.97	11230	4.32
BQ2031SN-A5	D	SOIC	16	40	506.6	8	3940	4.32
BQ2031SN-A5.Z	D	SOIC	16	40	506.6	8	3940	4.32

## IMPORTANT NOTICE AND DISCLAIMER

TI PROVIDES TECHNICAL AND RELIABILITY DATA (INCLUDING DATA SHEETS), DESIGN RESOURCES (INCLUDING REFERENCE DESIGNS), APPLICATION OR OTHER DESIGN ADVICE, WEB TOOLS, SAFETY INFORMATION, AND OTHER RESOURCES "AS IS" AND WITH ALL FAULTS, AND DISCLAIMS ALL WARRANTIES, EXPRESS AND IMPLIED, INCLUDING WITHOUT LIMITATION ANY IMPLIED WARRANTIES OF MERCHANTABILITY, FITNESS FOR A PARTICULAR PURPOSE OR NON-INFRINGEMENT OF THIRD PARTY INTELLECTUAL PROPERTY RIGHTS.

These resources are intended for skilled developers designing with TI products. You are solely responsible for (1) selecting the appropriate TI products for your application, (2) designing, validating and testing your application, and (3) ensuring your application meets applicable standards, and any other safety, security, regulatory or other requirements.

These resources are subject to change without notice. TI grants you permission to use these resources only for development of an application that uses the TI products described in the resource. Other reproduction and display of these resources is prohibited. No license is granted to any other TI intellectual property right or to any third party intellectual property right. TI disclaims responsibility for, and you will fully indemnify TI and its representatives against, any claims, damages, costs, losses, and liabilities arising out of your use of these resources.

TI's products are provided subject to [TI's Terms of Sale](#) or other applicable terms available either on [ti.com](https://www.ti.com) or provided in conjunction with such TI products. TI's provision of these resources does not expand or otherwise alter TI's applicable warranties or warranty disclaimers for TI products.

TI objects to and rejects any additional or different terms you may have proposed.

Mailing Address: Texas Instruments, Post Office Box 655303, Dallas, Texas 75265

Copyright © 2025, Texas Instruments Incorporated