

## 16-BIT DIGITAL-TO-ANALOG CONVERTER with 16-Bit Bus Interface

### FEATURES

- **HIGH-SPEED, 16-BIT PARALLEL DOUBLE-BUFFERED INTERFACE**
- **VOLTAGE OUTPUT:  $\pm 10\text{V}$**
- **13-, 14-, AND 15-BIT LINEARITY GRADES**
- **16-BIT MONOTONIC OVER TEMPERATURE (L GRADE)**
- **POWER DISSIPATION: 600mW max**
- **GAIN AND OFFSET ADJUST: Convenient for Auto-Cal D/A Converters**
- **28-LEAD DIP AND SOIC PACKAGES**

### DESCRIPTION

The DAC712 is a complete 16-bit resolution digital-to-analog (D/A) converter with 16 bits of monotonicity over temperature.

The DAC712 has a precision  $+10\text{V}$  temperature-compensated voltage reference,  $\pm 10\text{V}$  output amplifier, and 16-bit port bus interface.

The digital interface is fast, 60ns minimum write pulse width, double-buffered, and has a CLEAR function that resets the analog output to bipolar zero.

GAIN and OFFSET adjustment inputs are arranged so that they can be easily trimmed by external D/A converters as well as by potentiometers.

The DAC712 is available in two linearity error performance grades:  $\pm 4\text{LSB}$  and  $\pm 2\text{LSB}$ , and three differential linearity grades:  $\pm 4\text{LSB}$ ,  $\pm 2\text{LSB}$ , and  $\pm 1\text{LSB}$ . The DAC712 is specified at power-supply voltages of  $\pm 12\text{V}$  and  $\pm 15\text{V}$ .

The DAC712 is packaged in a 28-pin, 0.3" wide plastic DIP and in a 28-lead, wide-body plastic SOIC. The DAC712P, U, PB, and UB are specified over the  $-40^\circ\text{C}$  to  $+85^\circ\text{C}$  temperature range and the DAC712PK, UK, PL, and UL are specified over the  $0^\circ\text{C}$  to  $+70^\circ\text{C}$  range.

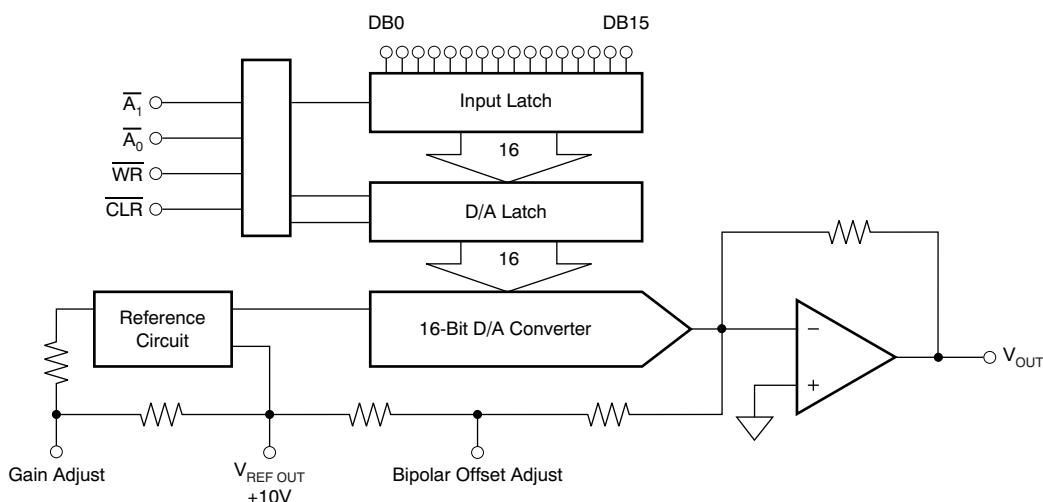

Please be aware that an important notice concerning availability, standard warranty, and use in critical applications of Texas Instruments semiconductor products and disclaimers thereto appears at the end of this data sheet.

All trademarks are the property of their respective owners.



This integrated circuit can be damaged by ESD. Texas Instruments recommends that all integrated circuits be handled with appropriate precautions. Failure to observe proper handling and installation procedures can cause damage.

ESD damage can range from subtle performance degradation to complete device failure. Precision integrated circuits may be more susceptible to damage because very small parametric changes could cause the device not to meet its published specifications.

**PACKAGE/ORDERING INFORMATION<sup>(1)</sup>**

PRODUCT	LINEARITY ERROR MAX AT +25°C	DIFFERENTIAL LINEARITY ERROR MAX AT +25°C	PACKAGE-LEAD	PACKAGE DESIGNATOR	SPECIFIED TEMPERATURE RANGE
DAC712P	±4LSB	±4LSB	PDIP-28	NT	-40°C to +85°C
DAC712U	±4LSB	±4LSB	SOIC-28	DW	-40°C to +85°C
DAC712PB	±2LSB	±2LSB	PDIP-28	NT	-40°C to +85°C
DAC712UB	±2LSB	±2LSB	SOIC-28	DW	-40°C to +85°C
DAC712PK	±2LSB	±2LSB	PDIP-28	NT	0°C to +70°C
DAC712UK	±2LSB	±2LSB	SOIC-28	DW	0°C to +70°C
DAC712PL	±2LSB	±1LSB	PDIP-28	NT	0°C to +70°C
DAC712UL	±2LSB	±1LSB	SOIC-28	DW	0°C to +70°C

(1) For the most current package and ordering information see the Package Option Addendum at the end of this document, or see the TI web site at [www.ti.com](http://www.ti.com).

**ABSOLUTE MAXIMUM RATINGS<sup>(1)</sup>**

	DAC712	UNIT
+V <sub>CC</sub> to COMMON	0, +17	V
-V <sub>CC</sub> to COMMON	0, -17	V
+V <sub>CC</sub> to -V <sub>CC</sub>	34	V
Digital Inputs to COMMON	-1 to +V <sub>CC</sub> - 0.7	V
External Voltage Applied to BPO and Range Resistors	±V <sub>CC</sub>	V
V <sub>REF OUT</sub>	Indefinite Short to COMMON	
V <sub>OUT</sub>	Indefinite Short to COMMON	
Power Dissipation	750	mW
Storage Temperature Range	-60 to +150	°C

(1) Stresses above these ratings may cause permanent damage. Exposure to absolute maximum conditions for extended periods may degrade device reliability. These are stress ratings only, and functional operation of the device at these or any other conditions beyond those specified is not implied.

**TRUTH TABLE**

$\overline{A_0}$	$\overline{A_1}$	$\overline{WR}$	$\overline{CLR}$	DESCRIPTION
0	1	1 → 0 → 1	1	Load Input Latch
1	0	1 → 0 → 1	1	Load D/A Latch
1	1	1 → 0 → 1	1	No Change
0	0	0	1	Latches Transparent
X	X	1	1	No Change
X	X	X	0	Reset D/A Latch

**ELECTRICAL CHARACTERISTICS: DAC712P, U, PB, UB**

 At  $T_A = +25^\circ\text{C}$ ,  $+V_{CC} = +12\text{V}$  and  $+15\text{V}$ , and  $-V_{CC} = -12\text{V}$  and  $-15\text{V}$ , unless otherwise noted.

PARAMETER	TEST CONDITIONS	DAC712P, U			DAC712PB, UB <sup>(1)</sup>			UNIT
		MIN	TYP	MAX	MIN	TYP	MAX	
<b>INPUT</b>								
<b>RESOLUTION</b>								
Resolution			16					Bits
<b>DIGITAL INPUTS</b>								
Input Code		Binary Twos Complement						
Logic Levels <sup>(2)</sup>								
$V_{IH}$		+2.0		$+V_{CC} - 1.4$				V
$V_{IL}$		0		+0.8				V
$I_{IH}$ ( $V_I = +2.7\text{V}$ )				$\pm 10$				$\mu\text{A}$
$I_{IL}$ ( $V_I = +0.4\text{V}$ )				$\pm 10$				$\mu\text{A}$
<b>TRANSFER CHARACTERISTICS</b>								
<b>ACCURACY</b>								
Linearity Error				$\pm 4$			$\pm 2$	LSB
$T_{MIN}$ to $T_{MAX}$				$\pm 8$			$\pm 4$	LSB
Differential Linearity Error				$\pm 4$			$\pm 2$	LSB
$T_{MIN}$ to $T_{MAX}$				$\pm 8$			$\pm 4$	LSB
Monotonicity Over Temperature		13			14			Bits
Gain Error <sup>(3)</sup>				$\pm 0.1$				%
$T_{MIN}$ to $T_{MAX}$				$\pm 0.2$			$\pm 0.15$	%
Bipolar Zero Error <sup>(3)</sup>				$\pm 0.1$				% FSR <sup>(4)</sup>
				$\pm 20$				mV
$T_{MIN}$ to $T_{MAX}$				$\pm 0.2$			$\pm 0.15$	% FSR
				$\pm 40$			$\pm 30$	mV
Power-Supply Sensitivity of Full-Scale				$\pm 0.003$				% FSR/% $V_{CC}$
				$\pm 30$				ppm FSR/% $V_{CC}$
<b>DYNAMIC PERFORMANCE</b>								
Settling Time (to $\pm 0.003\%$ FSR, $5\text{k}\Omega \parallel 500\text{pF}$ Load) <sup>(5)</sup>								
20V Output Step			6				10	$\mu\text{s}$
1LSB Output Step <sup>(6)</sup>			4					$\mu\text{s}$
Output Slew Rate			10					$\text{V}/\mu\text{s}$
Total Harmonic Distortion + Noise								
0dB, 1001Hz, $f_S = 100\text{kHz}$			0.005					%
-20dB, 1001Hz, $f_S = 100\text{kHz}$			0.03					%
-60dB, 1001Hz, $f_S = 100\text{kHz}$			3.0					%
SINAD								
1001Hz, $f_S = 100\text{kHz}$			87					dB
Digital Feedthrough <sup>(6)</sup>			2					nV-s
Digital-to-Analog Glitch Impulse <sup>(6)</sup>			15					nV-s
Output Noise Voltage (Includes Reference)			120					$\text{nV}/\sqrt{\text{Hz}}$

(1) Shaded cells indicate same specification as the DAC712P, U grade.

(2) Digital inputs are TTL- and +5V CMOS-compatible over the specified temperature range.

(3) Errors externally adjustable to zero.

(4) FSR means Full-Scale Range. For example, for a  $\pm 10\text{V}$  output, FSR = 20V.

(5) Maximum represents the  $3\sigma$  limit. Not 100% tested for this parameter.

(6) For the worst-case code changes: FFFFh to 0000h and 0000h to FFFFh. These are binary twos complement (BTC) codes.

**ELECTRICAL CHARACTERISTICS: DAC712P, U, PB, UB (continued)**

At  $T_A = +25^\circ\text{C}$ ,  $+V_{CC} = +12\text{V}$  and  $+15\text{V}$ , and  $-V_{CC} = -12\text{V}$  and  $-15\text{V}$ , unless otherwise noted.

PARAMETER	TEST CONDITIONS	DAC712P, U			DAC712PB, UB <sup>(1)</sup>			UNIT
		MIN	TYP	MAX	MIN	TYP	MAX	
<b>ANALOG OUTPUT</b>								
Output Voltage Range								
+ $V_{CC}$ , - $V_{CC} = \pm 11.4\text{V}$		$\pm 10$						V
Output Current		$\pm 5$						mA
Output Impedance			0.1					$\Omega$
Short-Circuit to ACOM, Duration			Indefinite					
<b>REFERENCE VOLTAGE</b>								
Voltage		+9.975	+10.000	+10.025				V
$T_{MIN}$ to $T_{MAX}$		+9.960		+10.040				V
Output Resistance			1					$\Omega$
Source Current		2						mA
Short-Circuit to ACOM, Duration			Indefinite					
<b>POWER-SUPPLY REQUIREMENTS</b>								
Voltage								
+ $V_{CC}$		+11.4	+15	+16.5				V
- $V_{CC}$		-11.4	-15	-16.5				V
Current (No Load, $\pm 15\text{V}$ Supplies)								
+ $V_{CC}$			13	15				mA
- $V_{CC}$			22	25				mA
Power Dissipation <sup>(7)</sup>			525	600				mW
<b>TEMPERATURE RANGES</b>								
Specified Temperature Range (All Grades)		-40		+85				$^\circ\text{C}$
Storage Temperature Range		-60		+150				$^\circ\text{C}$
Thermal Coefficient, $\theta_{JA}$								
DIP Package			75					$^\circ\text{C/W}$
SOIC Package			75					$^\circ\text{C/W}$

(7) Typical supply voltages times maximum currents.

**ELECTRICAL CHARACTERISTICS: DAC712PK, UK, PL, UL**

 At  $T_A = +25^\circ\text{C}$ ,  $+V_{CC} = +12\text{V}$  and  $+15\text{V}$ , and  $-V_{CC} = -12\text{V}$  and  $-15\text{V}$ , unless otherwise noted.

PARAMETER	TEST CONDITIONS	DAC712PK, UK			DAC712PL, UL <sup>(1)</sup>			UNIT
		MIN	TYP	MAX	MIN	TYP	MAX	
<b>INPUT</b>								
<b>RESOLUTION</b>								
Resolution			16					Bits
<b>DIGITAL INPUTS</b>								
Input Code		Binary Twos Complement						
Logic Levels <sup>(2)</sup>								
$V_{IH}$		+2.0		$+V_{CC} - 1.4$				V
$V_{IL}$		0		+0.8				V
$I_{IH}$ ( $V_I = +2.7\text{V}$ )				$\pm 10$				$\mu\text{A}$
$I_{IL}$ ( $V_I = +0.4\text{V}$ )				$\pm 10$				$\mu\text{A}$
<b>TRANSFER CHARACTERISTICS</b>								
<b>ACCURACY</b>								
Linearity Error				$\pm 2$				LSB
$T_{MIN}$ to $T_{MAX}$				$\pm 2$				LSB
Differential Linearity Error				$\pm 2$			$\pm 1$	LSB
$T_{MIN}$ to $T_{MAX}$				$\pm 2$			$\pm 1$	LSB
Monotonicity Over Temperature		15			16			Bits
Gain Error <sup>(3)</sup>				$\pm 0.1$				%
$T_{MIN}$ to $T_{MAX}$				$\pm 0.15$			$\pm 0.2$	%
Bipolar Zero Error <sup>(3)</sup>				$\pm 0.1$				% FSR <sup>(4)</sup>
				$\pm 20$				mV
$T_{MIN}$ to $T_{MAX}$				$\pm 0.15$				% FSR
				$\pm 30$				mV
Power-Supply Sensitivity of Full-Scale				$\pm 0.003$				% FSR/% $V_{CC}$
				$\pm 30$				ppm FSR/% $V_{CC}$
<b>DYNAMIC PERFORMANCE</b>								
Settling Time (to $\pm 0.003\%$ FSR, $5\text{k}\Omega \parallel 500\text{pF}$ Load) <sup>(5)</sup>								
20V Output Step			6	10				$\mu\text{s}$
1LSB Output Step <sup>(6)</sup>			4					$\mu\text{s}$
Output Slew Rate			10					V/ $\mu\text{s}$
Total Harmonic Distortion + Noise								
0dB, 1001Hz, $f_S = 100\text{kHz}$			0.005					%
-20dB, 1001Hz, $f_S = 100\text{kHz}$			0.03					%
-60dB, 1001Hz, $f_S = 100\text{kHz}$			3.0					%
SINAD								
1001Hz, $f_S = 100\text{kHz}$			87					dB
Digital Feedthrough <sup>(6)</sup>			2					nV-s
Digital-to-Analog Glitch Impulse <sup>(6)</sup>			15					nV-s
Output Noise Voltage (Includes Reference)			120					$\text{nV}/\sqrt{\text{Hz}}$

(1) Shaded cells indicate same specification as the DAC712PK, UK grade.

(2) Digital inputs are TTL- and +5V CMOS-compatible over the specified temperature range.

(3) Errors externally adjustable to zero.

 (4) FSR means Full-Scale Range. For example, for a  $\pm 10\text{V}$  output, FSR = 20V.

 (5) Maximum represents the  $3\sigma$  limit. Not 100% tested for this parameter.

(6) For the worst-case code changes: FFFFh to 0000h and 0000h to FFFFh. These are binary twos complement (BTC) codes.

**ELECTRICAL CHARACTERISTICS: DAC712PK, UK, PL, UL (continued)**At  $T_A = +25^\circ\text{C}$ ,  $+V_{CC} = +12\text{V}$  and  $+15\text{V}$ , and  $-V_{CC} = -12\text{V}$  and  $-15\text{V}$ , unless otherwise noted.

PARAMETER	TEST CONDITIONS	DAC712PK, UK			DAC712PL, UL <sup>(1)</sup>			UNIT
		MIN	TYP	MAX	MIN	TYP	MAX	
<b>ANALOG OUTPUT</b>								
Output Voltage Range								
+ $V_{CC}$ , - $V_{CC} = \pm 11.4\text{V}$		$\pm 10$						V
Output Current		$\pm 5$						mA
Output Impedance			0.1					$\Omega$
Short-Circuit to ACOM, Duration			Indefinite					
<b>REFERENCE VOLTAGE</b>								
Voltage		+9.975	+10.000	+10.025				V
$T_{\text{MIN}}$ to $T_{\text{MAX}}$		+9.960		+10.040				V
Output Resistance			1					$\Omega$
Source Current		2						mA
Short-Circuit to ACOM, Duration			Indefinite					
<b>POWER-SUPPLY REQUIREMENTS</b>								
Voltage								
+ $V_{CC}$		+11.4	+15	+16.5				V
- $V_{CC}$		-11.4	-15	-16.5				V
Current (No Load, $\pm 15\text{V}$ Supplies)								
+ $V_{CC}$			13	15				mA
- $V_{CC}$			22	25				mA
Power Dissipation <sup>(7)</sup>			525	600				mW
<b>TEMPERATURE RANGES</b>								
Specified Temperature Range (All Grades)		0		+70				$^\circ\text{C}$
Storage Temperature Range		-60		+150				$^\circ\text{C}$
Thermal Coefficient, $\theta_{JA}$								
DIP Package			75					$^\circ\text{C}/\text{W}$
SOIC Package			75					$^\circ\text{C}/\text{W}$

(7) Typical supply voltages times maximum currents.

**PIN CONFIGURATION**

**DW AND NT PACKAGES  
SOIC-28 AND PDIP-28  
(TOP VIEW)**



### PIN DESCRIPTIONS

PIN	NAME	DESCRIPTION
1	DCOM	Power-Supply return for digital currents
2	ACOM	Analog Supply Return
3	V <sub>OUT</sub>	±10V D/A Output
4	Offset Adjust	Offset Adjust (Bipolar)
5	V <sub>REF OUT</sub>	Voltage Reference Output
6	Gain Adjust	Gain Adjust
7	+V <sub>CC</sub>	+12V to +15V Supply
8	-V <sub>CC</sub>	-12V to -15V Supply
9	$\overline{\text{CLR}}$	CLEAR; Sets D/A output to Bipolar Zero (Active Low)
10	$\overline{\text{WR}}$	Write (Active Low)
11	$\overline{\text{A}}_1$	Enable for D/A latch (Active Low)
12	$\overline{\text{A}}_0$	Enable for Input latch (Active Low)
13	D15	Data Bit 15 (Most Significant Bit)
14	D14	Data Bit 14
15	D13	Data Bit 13
16	D12	Data Bit 12
17	D11	Data Bit 11
18	D10	Data Bit 10
19	D9	Data Bit 9
20	D8	Data Bit 8
21	D7	Data Bit 7
22	D6	Data Bit 6
23	D5	Data Bit 5
24	D4	Data Bit 4
25	D3	Data Bit 3
26	D2	Data Bit 2
27	D1	Data Bit 1
28	D0	Data Bit 0 (Least Significant Bit)



## TIMING CHARACTERISTICS



Figure 1. Timing Diagram

## TIMING REQUIREMENTS

At  $T_A = -40^\circ\text{C}$  to  $+85^\circ\text{C}$ ,  $+V_{CC} = +12\text{V}$  or  $+15\text{V}$ , and  $-V_{CC} = -12\text{V}$  or  $-15\text{V}$ , unless otherwise noted.

PARAMETER	TEST CONDITIONS	DAC712			UNIT
		MIN	TYP	MAX	
$t_{Dw}$	Data Valid to End of $\overline{WR}$	50			ns
$t_{AW}$	$\overline{A_0}, \overline{A_1}$ Valid to End of $\overline{WR}$	50			ns
$t_{AH}$	$\overline{A_0}, \overline{A_1}$ Hold after End of $\overline{WR}$	10			ns
$t_{DH}$	Data Hold after End of $\overline{WR}$	10			ns
$t_{WP}^{(1)}$	Write Pulse Width	50			ns
$t_{CP}$	CLEAR Pulse Width	200			ns

(1) For single-buffered operation,  $t_{WP}$  is 80ns minimum; see the [Single-Buffered Operation](#) section.

### TYPICAL CHARACTERISTICS

At  $T_A = +25^\circ\text{C}$  and  $V_{CC} = \pm 15\text{V}$ , unless otherwise noted.

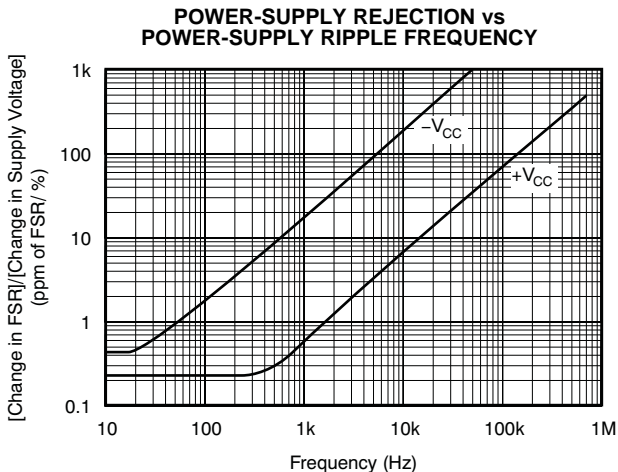

Figure 2.

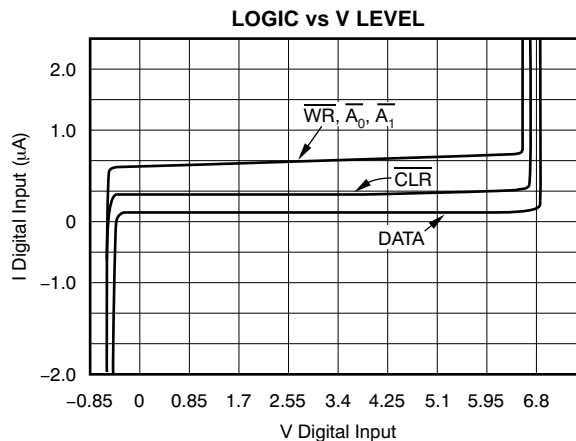

Figure 3.

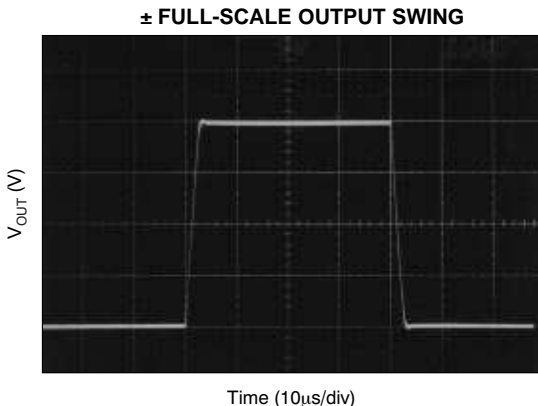

Figure 4.

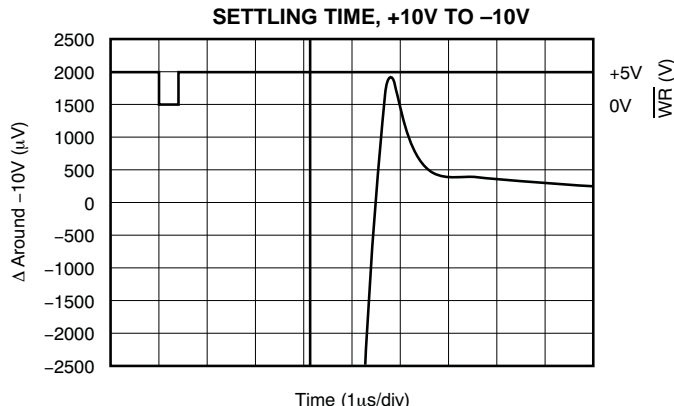

Figure 5.

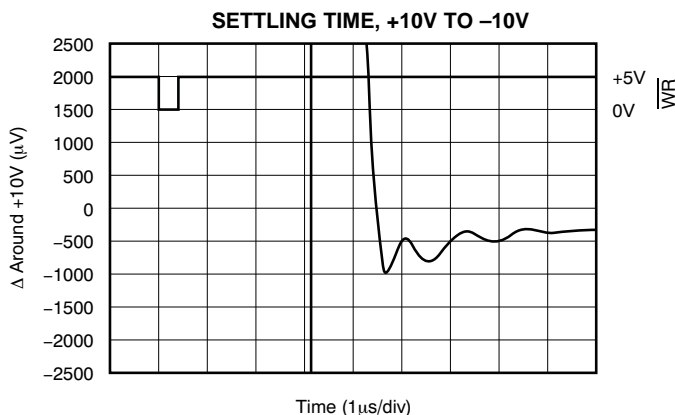

Figure 6.

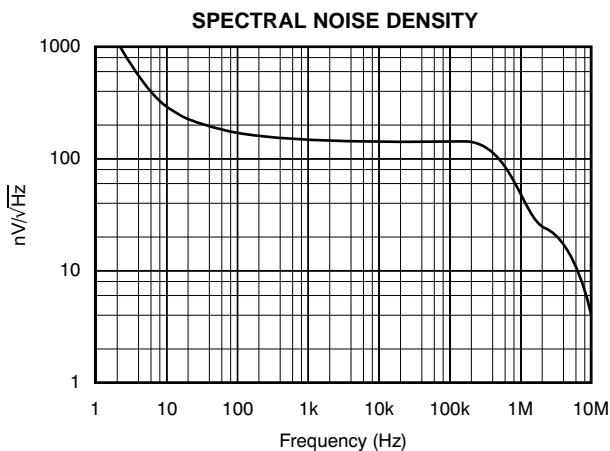

Figure 7.

## DISCUSSION OF SPECIFICATIONS

### LINEARITY ERROR

Linearity error is defined as the deviation of the analog output from a straight line drawn between the end points of the transfer characteristic.

### DIFFERENTIAL LINEARITY ERROR

Differential linearity error (DLE) is the deviation from 1LSB of an output change from one adjacent state to the next. A DLE specification of  $\pm 1/2$ LSB means that the output step size can range from  $1/2$ LSB to  $3/2$ LSB when the digital input code changes from one code word to the adjacent code word. If the DLE is more positive than  $-1$ LSB, the D/A converter is said to be monotonic.

### MONOTONICITY

A D/A converter is monotonic if the output either increases or remains the same for increasing digital input values. Monotonicity of the DAC712 is ensured over the specified temperature range to 13, 14, 15, and 16 bits for performance grades DAC712P/U, DAC712PB/UB, DAC712PK/UK, and DAC712PL/UL, respectively.

### SETTLING TIME

Settling time is the total time (including slew time) for the D/A output to settle to within an error band around its final value after a change in input. Settling times are specified to within  $\pm 0.003\%$  of Full-Scale Range (FSR) for an output step change of 20V and 1LSB. The 1LSB change is measured at the Major Carry (FFFFh to 0000h, and 0000h to FFFFh: BTC codes), the input transition at which worst-case settling time occurs.

### TOTAL HARMONIC DISTORTION + NOISE

Total harmonic distortion + noise is defined as the ratio of the square root of the sum of the squares of the values of the harmonics and noise to the value of the fundamental frequency. It is expressed in % of the fundamental frequency amplitude at sampling rate  $f_s$ .

### SIGNAL-TO-NOISE AND DISTORTION RATIO (SINAD)

SINAD includes all the harmonic and outstanding spurious components in the definition of output noise power in addition to quantizing and internal random noise power. SINAD is expressed in dB at a specified input frequency and sampling rate,  $f_s$ .

### DIGITAL-TO-ANALOG GLITCH IMPULSE

The amount of charge injected into the analog output from the digital inputs when the inputs change state. It is measured at half-scale at the input codes where as many switches as possible change state—from 7FFFh to 8000h.

### DIGITAL FEEDTHROUGH

When the analog-to-digital (A/D) converter is not selected, high-frequency logic activity on the digital inputs is coupled through the device and shows up as output noise. This noise is digital feedthrough.

### OPERATION

The DAC712 is a monolithic integrated-circuit, 16-bit D/A converter complete with 16-bit D/A converter switches and ladder network, voltage reference, output amplifier, and microprocessor bus interface.

All latches are level-triggered. Data present when the enable inputs are logic '0' enter the latch. When the enable inputs return to logic '1', the data are latched.

The  $\overline{\text{CLR}}$  input resets both the input latch and the D/A latch to give a bipolar zero output.

### INTERFACE LOGIC

The DAC712 has double-buffered data latches. The input data latch holds a 16-bit data word before loading it into the second latch, the D/A latch. This double-buffered organization permits simultaneous update of several D/A converters. All digital control inputs are active low. Refer to the block diagram of Figure 8.



Figure 8. DAC712 Block Diagram

### LOGIC INPUT COMPATIBILITY

The DAC712 digital inputs are TTL-compatible (1.4V switching level) with low-leakage, high-impedance inputs. Thus, the inputs are suitable for being driven by any type of 5V logic such as 5V CMOS logic. An equivalent circuit of a digital input is shown in Figure 9.

Data inputs float to logic '0' and control inputs float to logic '0' if left unconnected. It is recommended that any unused inputs be connected to DCOM to improve noise immunity.

Digital inputs remain high-impedance when power is off.



Figure 9. Equivalent Circuit of Digital Inputs

### INPUT CODING

The DAC712 is designed to accept positive-true binary twos complement (BTC) input codes that are compatible with bipolar analog output operation. For bipolar analog output configuration, a digital input of 7FFFh gives a positive full-scale output, 8000h gives a negative full-scale output, and 0000h gives bipolar zero output.

### INTERNAL REFERENCE

The DAC712 contains a +10V reference.

The reference output may be used to drive external loads, sourcing up to 2mA. The load current should be constant, otherwise the gain and bipolar offset of the converter will vary.

### OUTPUT VOLTAGE SWING

The output amplifier of the DAC712 is committed to a ±10V output range. The DAC712 provides a ±10V output swing while operating on ±11.4V or higher voltage supplies.

### GAIN AND OFFSET ADJUSTMENTS

Figure 10 illustrates the relationship of offset and gain adjustments for a bipolar connected D/A converter. Offset should be adjusted first to avoid interaction of adjustments. Table 1 shows calibration values and codes. These adjustments have a minimum range of ±0.3%.

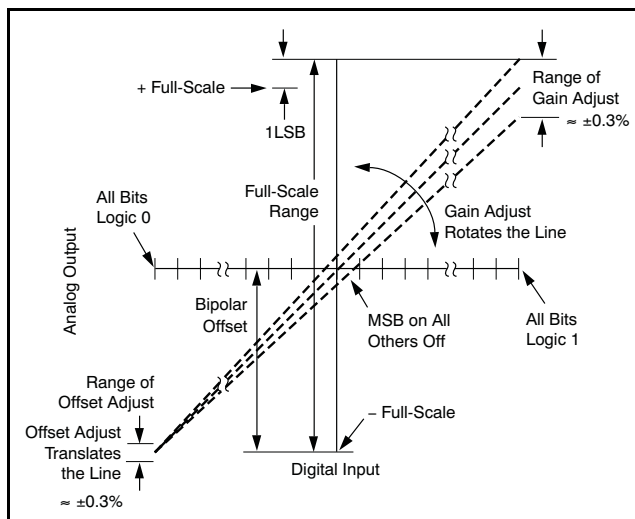

Figure 10. Relationship of Offset and Gain Adjustments

Table 1. Digital Input and Analog Output Voltage Calibration Values

DAC712 CALIBRATION VALUES 1 LEAST SIGNIFICANT BIT = 305µV		
DIGITAL INPUT CODE BINARY TWOS COMPLEMENT, BTC	ANALOG OUTPUT (V)	DESCRIPTION
7FFFh	+9.999695	Positive Full-Scale – 1LSB
4000h	+5.000000	3/4 Scale
0001h	+0.000305	BPZ + 1LSB
0000h	0.000000	Bipolar Zero (BPZ)
FFFFh	–0.000305	BPZ – 1LSB
C000h	–5.000000	1/4 Scale
8000h	–10.000000	Negative Full-Scale

### Offset Adjustment

Apply the digital input code that produces the maximum negative output voltage and adjust the offset potentiometer or the offset adjust D/A converter for –10V.

## Gain Adjustment

Apply the digital input that gives the maximum positive voltage output. Adjust the gain potentiometer or the gain adjust D/A converter for this positive full-scale voltage.

## INSTALLATION

### GENERAL CONSIDERATIONS

Because of the high accuracy of these D/A converters, system design problems such as grounding and contact resistance become very important. A 16-bit converter with a 20V full-scale range has a 1LSB value of 305mV. With a load current of 5 $\mu$ A, series wiring and connector resistance of only 60m $\Omega$  causes a voltage drop of 300 $\mu$ V. To understand what this means in terms of a system layout, the resistivity of a typical 1-ounce copper-clad printed circuit board (PCB) is 1/2m $\Omega$  per square. For a 5mA load, a 10 mil (0.010 inch) wide printed circuit conductor 60 milli-inches long results in a voltage drop of 150 $\mu$ V.

The analog output of the DAC712 has an LSB size of 305 $\mu$ V (–96dB). The noise floor of the D/A converter must remain below this level in the frequency range of interest. The DAC712 noise spectral density (which includes the noise contributed by the internal reference) is shown in the [Typical Characteristics](#) section.

Wiring to high-resolution D/A converters should be routed to provide optimum isolation from sources of radio frequency interference (RFI) and electromagnetic interference (EMI). The key to elimination of RF radiation or pickup is a small loop area. Signal leads and the return conductors should be kept close together such that they present a small capture cross-section for any external field. Wire-wrap construction is not recommended.

### POWER-SUPPLY AND REFERENCE CONNECTIONS

Power-supply decoupling capacitors should be added as shown in [Figure 11](#). Best performance occurs using a 1 $\mu$ F to 10 $\mu$ F tantalum capacitor at  $-V_{CC}$ . Applications with less critical settling time may be able to use 0.01 $\mu$ F at  $-V_{CC}$  as well as at  $+V_{CC}$ . The capacitors should be located close to the package.



**Figure 11. Power-Supply Connections**

The DAC712 has separate ANALOG COMMON and DIGITAL COMMON pins. The current through DCOM is mostly switching transients and are up to 1mA peak in amplitude. The current through ACOM is typically 5 $\mu$ A for all codes.

Use separate analog and digital ground planes with a single interconnection point to minimize ground loops. The analog pins are located adjacent to each other to help isolate analog from digital signals. Analog signals should be routed as far as possible from digital signals and should cross them at right angles. A solid analog ground plane around the D/A converter package, as well as under it in the vicinity of the analog and power-supply pins, isolates the D/A converter from switching currents. It is recommended that DCOM and ACOM be connected directly to the ground planes under the package.

If several DAC712s are used, or if the DAC712 shares supplies with other components, connecting the ACOM and DCOM lines together once at the power supplies rather than at each chip may give better results.

### LOAD CONNECTIONS

Because the reference point for  $V_{OUT}$  and  $V_{REF OUT}$  is the ACOM pin, it is important to connect the D/A converter load directly to the ACOM pin; see Figure 12.

Lead and contact resistances are represented by  $R_1$  through  $R_3$ . As long as the load resistance  $R_L$  is constant,  $R_1$  simply introduces a gain error and can be removed by gain adjustment of the D/A converter or system-wide gain calibration.  $R_2$  is part of  $R_L$  if the output voltage is sensed at ACOM.

In some applications it is impractical to return the load to the ACOM pin of the D/A converter. Sensing the output voltage at the SYSTEM GROUND point is reasonable, because there is no change in the DAC712 ACOM current, provided that  $R_3$  is a low-resistance ground plane or conductor. In this case, DCOM may be connected to SYSTEM GROUND as well.

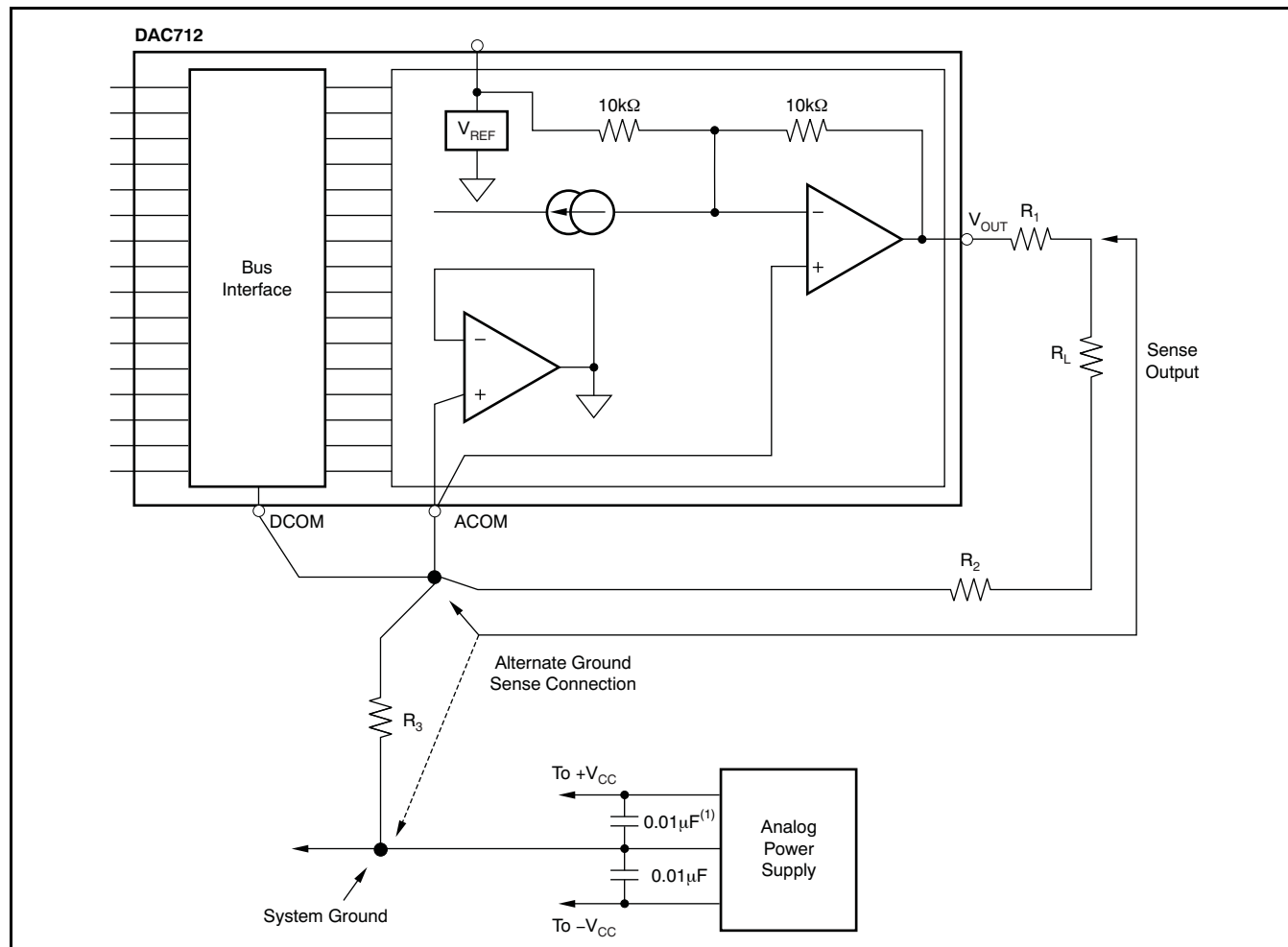

(1) Locate close to the DAC712 package.

Figure 12. System Ground Considerations for High-Resolution D/A Converters

## GAIN AND OFFSET ADJUST

### Connections Using Potentiometers

GAIN and OFFSET adjust pins provide for trim using external potentiometers. 15-turn potentiometers provide sufficient resolution. Range of adjustment of these trims is at least  $\pm 0.3\%$  of Full-Scale Range; see Figure 13.

### Using D/A Converters

The GAIN ADJUST and OFFSET ADJUST circuits of the DAC712 have been arranged so that these points may be easily driven by external D/A converters; see Figure 14. 12-bit D/A converters provide an OFFSET adjust resolution and a GAIN adjust resolution of  $30\mu\text{V}$  to  $50\mu\text{V}$  per LSB step.

Nominal values of GAIN and OFFSET occur when the D/A converter outputs are at approximately half scale, +5V.

### OUTPUT VOLTAGE RANGE CONNECTIONS

The DAC712 output amplifier is connected internally for the  $\pm 10\text{V}$  bipolar ( $20\text{V}$ ) output range. That is, the bipolar offset resistor is connected to an internal reference voltage and the  $20\text{V}$  range resistor is connected internally to  $V_{\text{OUT}}$ . The DAC712 cannot be connected for unipolar operation.



(1) For no external adjustments, pins 4 and 6 are not connected. External Resistors  $R_1$  to  $R_4$  are standard  $\pm 1\%$  values. Range of adjustment is at least  $\pm 0.3\%$  FSR.

Figure 13. Manual Offset and Gain Adjust Circuits



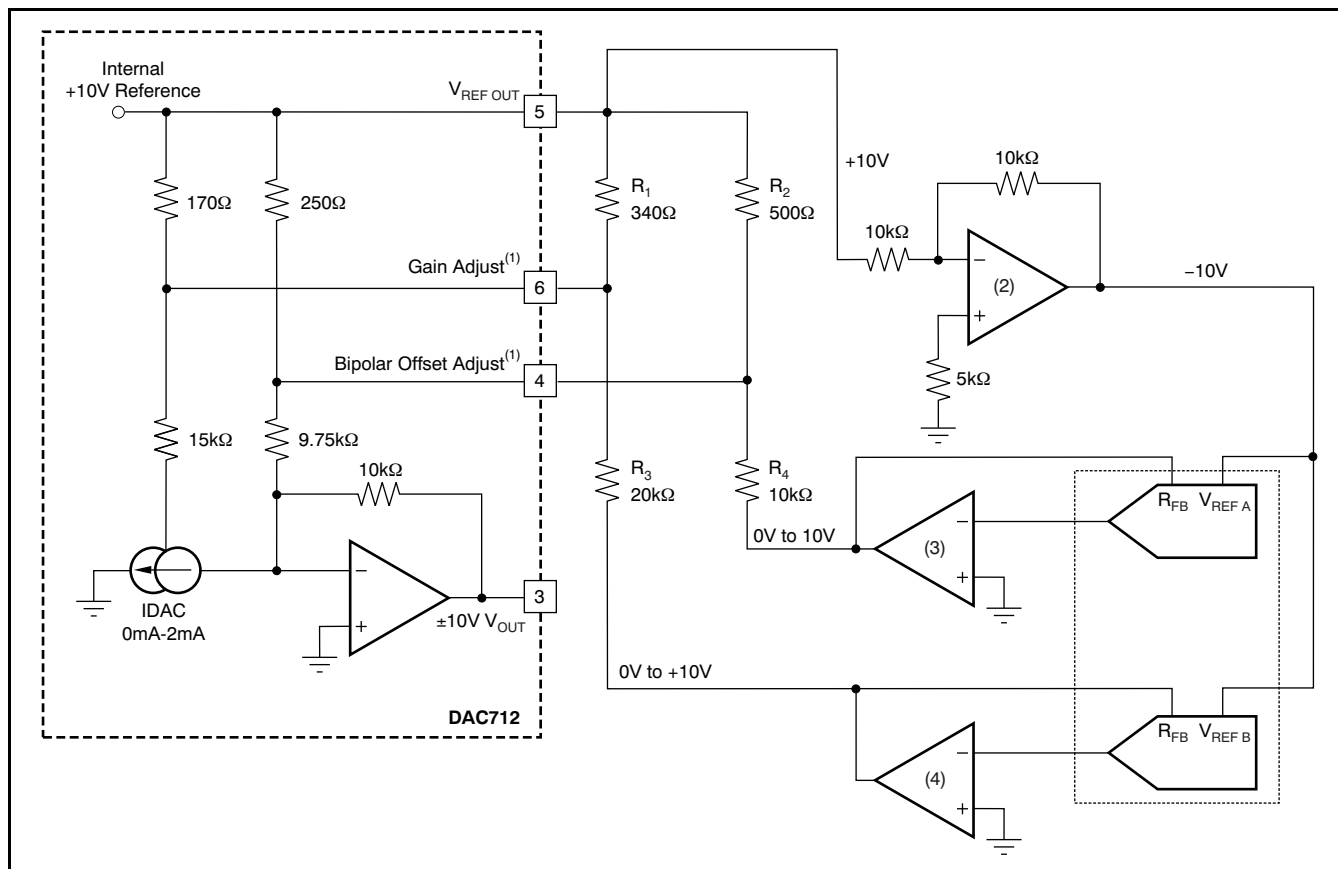

(1) For no external adjustments, pins 4 and 6 are not connected. External Resistors  $R_1$  to  $R_4$  tolerance is  $\pm 1\%$  values. Range of adjustment is at least  $\pm 0.3\%$  FSR.

(2) Suggested op amps: [OPA177GP, GS](#) or [OPA604AP, AU](#).

(3) Suggested op amps: single [OPA177GP, GS](#) or dual [OPA2604AP, AU](#).

(4) Suggested D/A converters: dual [DAC7800](#) (serial input, 12-bit resolution); dual [DAC7801](#) (8-bit port input, 12-bit resolution); dual [DAC7802](#) (12-bit port input, 12-bit resolution); dual [DAC7545](#) (12-bit port input, 12-bit resolution); or single [DAC8043](#) (serial input, 12-bit resolution). BIPOLAR (complete): [DAC813](#) (use 11-bit resolution for 0V to +10V output; no op-amps required).

Figure 14. Gain and Offset Adjustment Using D/A Converters

## DIGITAL INTERFACE

### BUS INTERFACE

The DAC712 has 16-bit, double-buffered data bus interface with control lines for easy interface to a 16-bit bus. The double-buffered feature permits update of several D/A converters simultaneously.

$\overline{A_0}$  is the enable control for the DATA INPUT LATCH.  $\overline{A_1}$  is the enable for the D/A LATCH.  $\overline{WR}$  is used to strobe data into latches enabled by  $\overline{A_0}$  and  $\overline{A_1}$ . Refer to the block diagram of [Figure 8](#) and to [Figure 1](#).

$\overline{CLR}$  sets the INPUT DATA LATCH to all zeros and the D/A LATCH to a code that gives bipolar 0V at the D/A converter output.

### SINGLE-BUFFERED OPERATION

To operate the DAC712 interface as a single-buffered latch, the DATA INPUT LATCH is permanently enabled by connecting  $\overline{A_0}$  to DCOM. If  $\overline{A_1}$  is not used to enable the D/A converter, it should be connected to DCOM as well. For this mode of operation, the width of  $\overline{WR}$  must be at least 80ns minimum to pass data through the DATA INPUT LATCH and into the D/A LATCH.

### TRANSPARENT INTERFACE

The digital interface of the DAC712 can be made transparent by asserting  $\overline{A_0}$ ,  $\overline{A_1}$ , and  $\overline{WR}$  LOW, and asserting CLR HIGH.

## Revision History

NOTE: Page numbers for previous revisions may differ from page numbers in the current version.

Changes from Original (September 200) to Revision A	Page
• Updated document format to current standards .....	1
• Changed max specification for Accuracy, Gain Error, $T_{MIN}$ to $T_{MAX}$ parameter in <i>Electrical Characteristics</i> : DAC712PK, UK, PL, UL table.....	5

**PACKAGING INFORMATION**

Orderable Device	Status (1)	Package Type	Package Drawing	Pins	Package Qty	Eco Plan (2)	Lead finish/ Ball material (6)	MSL Peak Temp (3)	Op Temp (°C)	Device Marking (4/5)	Samples
DAC712U	ACTIVE	SOIC	DW	28	20	RoHS & Green	NIPDAU	Level-3-260C-168 HR	-40 to 85	DAC712U	<a href="#">Samples</a>
DAC712UB	ACTIVE	SOIC	DW	28	20	RoHS & Green	NIPDAU	Level-3-260C-168 HR	-40 to 85	DAC712U B	<a href="#">Samples</a>
DAC712UBG4	ACTIVE	SOIC	DW	28	20	RoHS & Green	NIPDAU	Level-3-260C-168 HR	-40 to 85	DAC712U B	<a href="#">Samples</a>
DAC712UG4	ACTIVE	SOIC	DW	28	20	RoHS & Green	NIPDAU	Level-3-260C-168 HR	-40 to 85	DAC712U	<a href="#">Samples</a>
DAC712UK	ACTIVE	SOIC	DW	28	20	RoHS & Green	NIPDAU	Level-3-260C-168 HR	0 to 70	DAC712U K	<a href="#">Samples</a>
DAC712UKG4	ACTIVE	SOIC	DW	28	20	RoHS & Green	NIPDAU	Level-3-260C-168 HR	0 to 70	DAC712U K	<a href="#">Samples</a>
DAC712UL	ACTIVE	SOIC	DW	28	20	RoHS & Green	NIPDAU	Level-3-260C-168 HR	0 to 70	DAC712U L	<a href="#">Samples</a>
DAC712ULG4	ACTIVE	SOIC	DW	28	20	RoHS & Green	NIPDAU	Level-3-260C-168 HR	0 to 70	DAC712U L	<a href="#">Samples</a>

(1) The marketing status values are defined as follows:

**ACTIVE:** Product device recommended for new designs.

**LIFEBUY:** TI has announced that the device will be discontinued, and a lifetime-buy period is in effect.

**NRND:** Not recommended for new designs. Device is in production to support existing customers, but TI does not recommend using this part in a new design.

**PREVIEW:** Device has been announced but is not in production. Samples may or may not be available.

**OBSOLETE:** TI has discontinued the production of the device.

(2) **RoHS:** TI defines "RoHS" to mean semiconductor products that are compliant with the current EU RoHS requirements for all 10 RoHS substances, including the requirement that RoHS substance do not exceed 0.1% by weight in homogeneous materials. Where designed to be soldered at high temperatures, "RoHS" products are suitable for use in specified lead-free processes. TI may reference these types of products as "Pb-Free".

**RoHS Exempt:** TI defines "RoHS Exempt" to mean products that contain lead but are compliant with EU RoHS pursuant to a specific EU RoHS exemption.

**Green:** TI defines "Green" to mean the content of Chlorine (Cl) and Bromine (Br) based flame retardants meet JS709B low halogen requirements of <=1000ppm threshold. Antimony trioxide based flame retardants must also meet the <=1000ppm threshold requirement.

(3) MSL, Peak Temp. - The Moisture Sensitivity Level rating according to the JEDEC industry standard classifications, and peak solder temperature.

(4) There may be additional marking, which relates to the logo, the lot trace code information, or the environmental category on the device.

(5) Multiple Device Markings will be inside parentheses. Only one Device Marking contained in parentheses and separated by a "-" will appear on a device. If a line is indented then it is a continuation of the previous line and the two combined represent the entire Device Marking for that device.

(6) Lead finish/Ball material - Orderable Devices may have multiple material finish options. Finish options are separated by a vertical ruled line. Lead finish/Ball material values may wrap to two lines if the finish value exceeds the maximum column width.

**Important Information and Disclaimer:**The information provided on this page represents TI's knowledge and belief as of the date that it is provided. TI bases its knowledge and belief on information provided by third parties, and makes no representation or warranty as to the accuracy of such information. Efforts are underway to better integrate information from third parties. TI has taken and continues to take reasonable steps to provide representative and accurate information but may not have conducted destructive testing or chemical analysis on incoming materials and chemicals. TI and TI suppliers consider certain information to be proprietary, and thus CAS numbers and other limited information may not be available for release.

In no event shall TI's liability arising out of such information exceed the total purchase price of the TI part(s) at issue in this document sold by TI to Customer on an annual basis.

DW (R-PDSO-G28)

PLASTIC SMALL OUTLINE

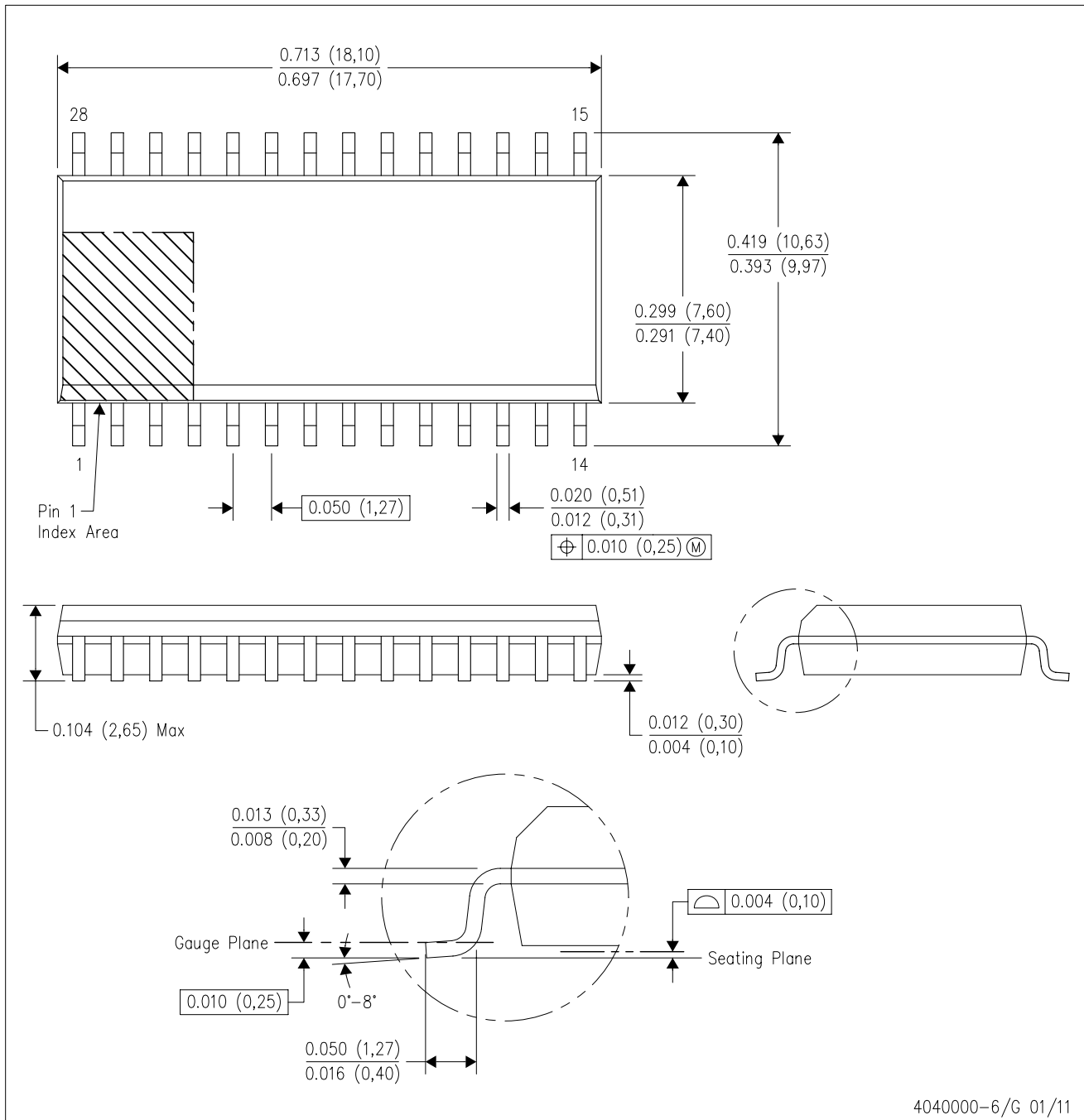

4040000-6/G 01/11

- NOTES:
- A. All linear dimensions are in inches (millimeters). Dimensioning and tolerancing per ASME Y14.5M-1994.
  - B. This drawing is subject to change without notice.
  - C. Body dimensions do not include mold flash or protrusion not to exceed 0.006 (0,15).
  - D. Falls within JEDEC MS-013 variation AE.

DW (R-PDSO-G28)

PLASTIC SMALL OUTLINE

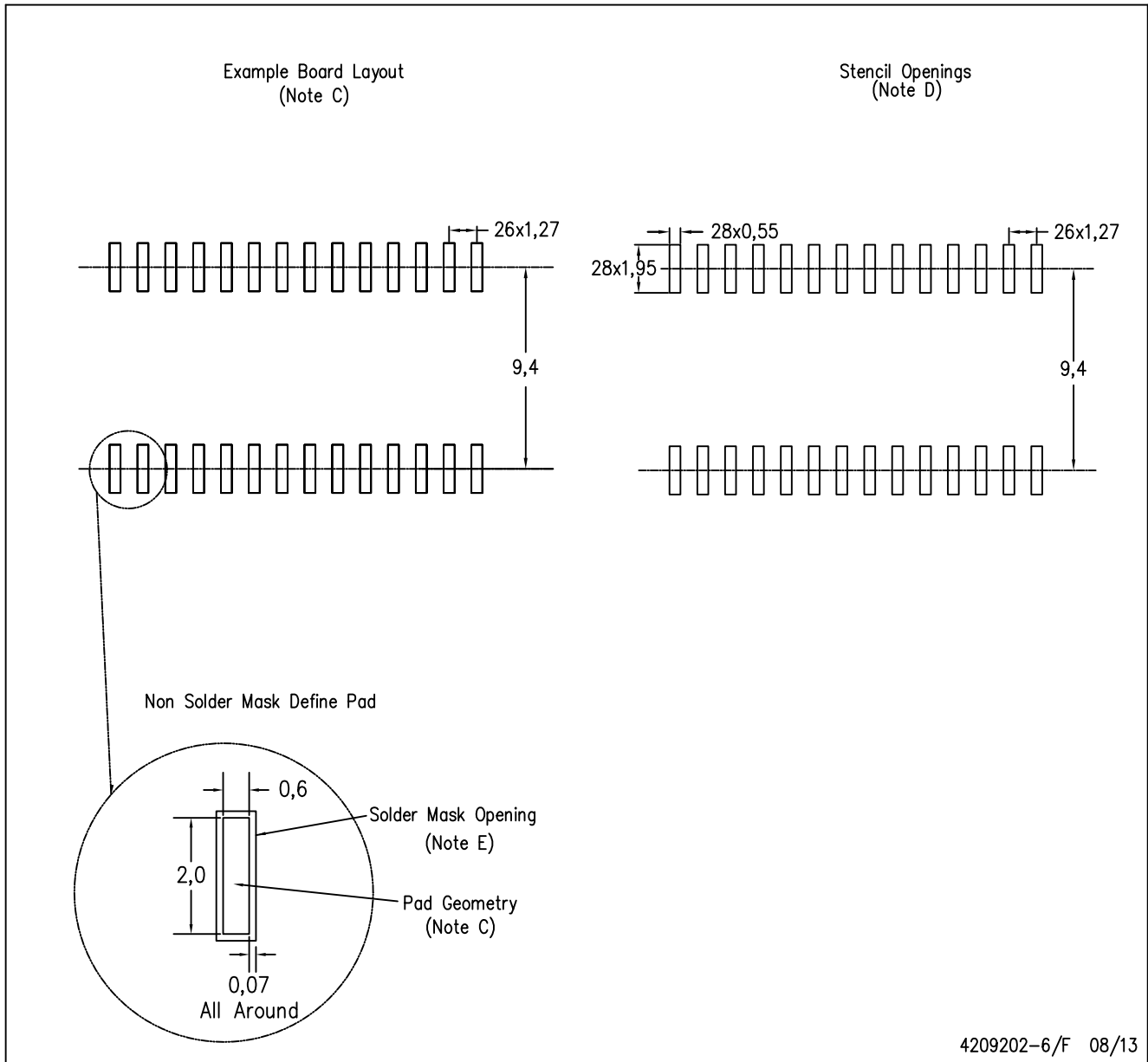

4209202-6/F 08/13

- NOTES:
- A. All linear dimensions are in millimeters.
  - B. This drawing is subject to change without notice.
  - C. Refer to IPC7351 for alternate board design.
  - D. Laser cutting apertures with trapezoidal walls and also rounding corners will offer better paste release. Customers should contact their board assembly site for stencil design recommendations. Refer to IPC-7525
  - E. Customers should contact their board fabrication site for solder mask tolerances between and around signal pads.

## IMPORTANT NOTICE AND DISCLAIMER

TI PROVIDES TECHNICAL AND RELIABILITY DATA (INCLUDING DATASHEETS), DESIGN RESOURCES (INCLUDING REFERENCE DESIGNS), APPLICATION OR OTHER DESIGN ADVICE, WEB TOOLS, SAFETY INFORMATION, AND OTHER RESOURCES "AS IS" AND WITH ALL FAULTS, AND DISCLAIMS ALL WARRANTIES, EXPRESS AND IMPLIED, INCLUDING WITHOUT LIMITATION ANY IMPLIED WARRANTIES OF MERCHANTABILITY, FITNESS FOR A PARTICULAR PURPOSE OR NON-INFRINGEMENT OF THIRD PARTY INTELLECTUAL PROPERTY RIGHTS.

These resources are intended for skilled developers designing with TI products. You are solely responsible for (1) selecting the appropriate TI products for your application, (2) designing, validating and testing your application, and (3) ensuring your application meets applicable standards, and any other safety, security, or other requirements. These resources are subject to change without notice. TI grants you permission to use these resources only for development of an application that uses the TI products described in the resource. Other reproduction and display of these resources is prohibited. No license is granted to any other TI intellectual property right or to any third party intellectual property right. TI disclaims responsibility for, and you will fully indemnify TI and its representatives against, any claims, damages, costs, losses, and liabilities arising out of your use of these resources.

TI's products are provided subject to TI's Terms of Sale ([www.ti.com/legal/termsofsale.html](http://www.ti.com/legal/termsofsale.html)) or other applicable terms available either on [ti.com](http://ti.com) or provided in conjunction with such TI products. TI's provision of these resources does not expand or otherwise alter TI's applicable warranties or warranty disclaimers for TI products.

Mailing Address: Texas Instruments, Post Office Box 655303, Dallas, Texas 75265  
Copyright © 2020, Texas Instruments Incorporated