

ISO1228 Eight-Channel Isolated Digital Input with Current Limit and Diagnostics

1 Features

- Configurable IEC 61131-2 eight Type 1/3 or four Type 2 Isolated Digital Inputs
- Low Power and Heat Dissipation
 - Selectable input current limit
 - Fieldside LED drivers using input current
- Configurable sinking or sourcing type inputs
- Wire-break detection in sink mode
- Integrated field-side power loss detection
- Programmable Glitch Filters
- Built in CRC check across barrier
- Serial SPI and Parallel output options
 - Supports SPI daisy chaining
 - Supports SPI burst mode
- Integrated IEC ESD and Surge Protection
- High CMTI(Typ): 75kV/μs
- V_{CC1} Logic supply voltage range: 1.71V to 5.5V
- AVCC field supply voltage range (sink mode): 8.5V to 36V
- AVCC field supply voltage range (source mode): 13V to 36V
- Ambient temperature range: –40°C to 125°C
- Small Footprint 38-SSOP Package
- Safety-related certifications:
 - 4242-V_{PK} V_{IOTM} and 637-V_{PK} V_{IORM} per DIN EN IEC 60747-17 (VDE 0884-17)
 - 3000-V_{RMS} Isolation for 1 Minute per UL 1577
 - IEC 62368-1, IEC 61010-1 Certifications
 - All Certifications Planned

2 Applications

- Programmable Logic Controllers (PLC)
 - Digital Input Modules
 - Mixed Input Modules
- Motor Drive Digital Inputs
- Binary Input Modules

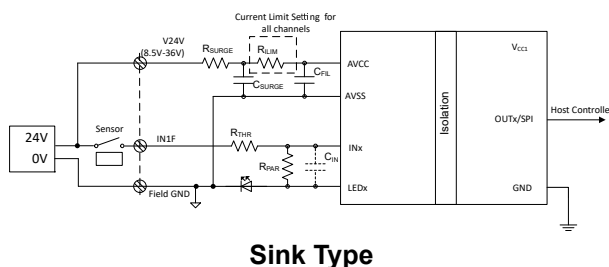

- CNC Control
- Industrial Transport Digital Inputs

3 Description

The ISO1228 is an eight-channel isolated 24V digital input receiver, configurable to IEC 61131-2 Type 1, and 3 characteristics or four-channel Type 2 characteristics. The ISO1228 includes resistor-programmable accurate current limit and field side input-current-powered LED indication to reduce system power dissipation and reduce board temperatures. ISO1228 can be configured for either sourcing or sinking type digital inputs with minimal hardware change. Both serial SPI and parallel output modes are available. Wire-break detection, fieldside supply monitoring and built-in CRC across barriers help improve system reliability. In-built glitch filters and integrated IEC-ESD and surge protection help to achieve a robust design.

The ISO1228 operates over the logic supply range of 1.71V to 5.5V, supporting 1.8V, 2.5-V, 3.3V, and 5V controllers. Field side output voltage range supported is 8.5V to 36V in sink mode and 13V to 36V in source mode. ISO1228 supports up to 1.5Mbps data rates passing a minimum pulse width of 667ns for high-speed operation.

Device Information

PART NUMBER	PACKAGE ⁽¹⁾	PACKAGE SIZE ⁽²⁾	BODY SIZE (NOM)
ISO1228	SSOP (38) DFB	9.9mm × 6.0mm	9.9mm × 3.90mm

- For all available packages, see the orderable addendum at the end of the data sheet.
- The package size (length × width) is a nominal value and includes pins, where applicable.

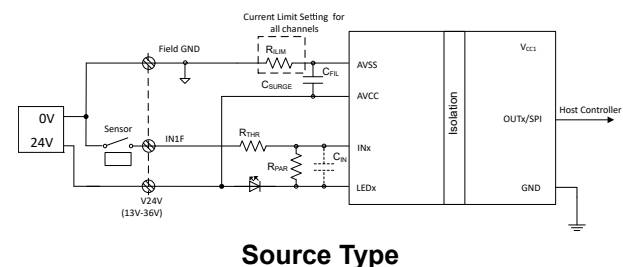

Table of Contents

1 Features	1	7.3 Feature Description.....	20
2 Applications	1	7.4 Device Functional Modes.....	26
3 Description	1	8 Application and Implementation	27
4 Pin Configuration and Functions	3	8.1 Application Information.....	27
5 Specifications	5	8.2 Typical Application.....	27
5.1 Absolute Maximum Ratings.....	5	9 Power Supply Recommendations	31
5.2 ESD Ratings.....	5	10 Layout	32
5.3 Recommended Operating Conditions.....	6	10.1 Layout Guidelines.....	32
5.4 Thermal Information.....	7	10.2 Layout Example.....	32
5.5 Power Ratings.....	7	11 Device and Documentation Support	33
5.6 Insulation Specifications.....	8	11.1 Documentation Support.....	33
5.7 Safety-Related Certifications.....	9	11.2 Receiving Notification of Documentation Updates..	33
5.8 Safety Limiting Values.....	9	11.3 Support Resources.....	33
5.9 Electrical Characteristics—DC Specification.....	10	11.4 Trademarks.....	33
5.10 Switching Characteristics—AC Specification.....	12	11.5 Electrostatic Discharge Caution.....	33
5.11 Typical Characteristics.....	15	11.6 Glossary.....	33
6 Parameter Measurement Information	17	12 Revision History	33
6.1 Test Circuits.....	17	13 Mechanical, Packaging, and Orderable Information	34
7 Detailed Description	19	13.1 Tape and Reel Information.....	38
7.1 Overview.....	19		
7.2 Functional Block Diagram.....	19		

4 Pin Configuration and Functions

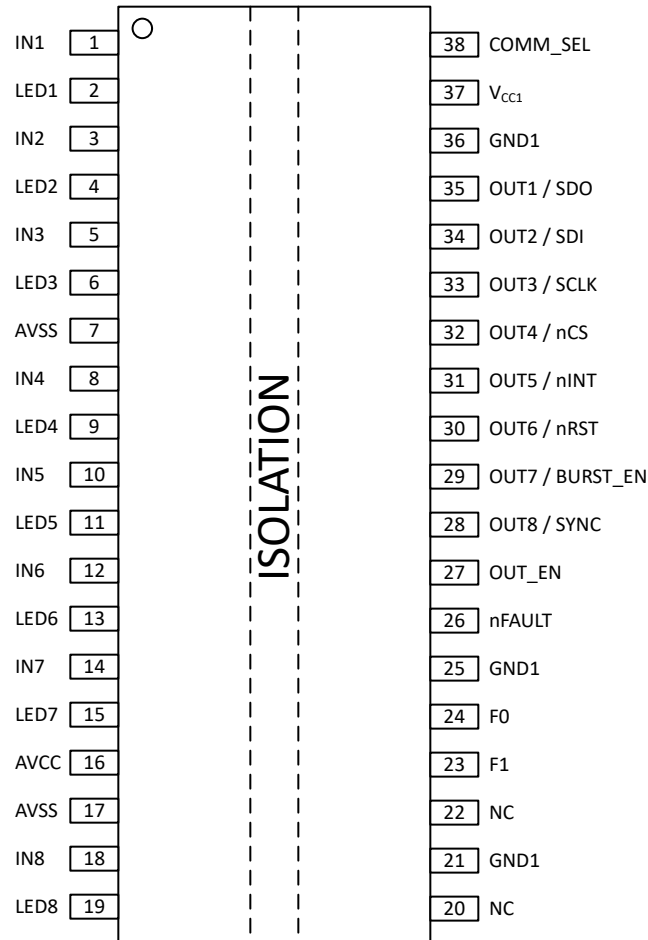

Figure 4-1. ISO1228

Table 4-1. Pin Functions—38 Pins

PIN		I/O	DESCRIPTION
NO.	NAME		
1	IN1	I/O	Field Input, Channel 1
2	LED1	I/O	LED Indication Pin, Channel 1
3	IN2	I/O	Field Input, Channel 2
4	LED2	I/O	LED Indication Pin, Channel 2
5	IN3	I/O	Field Input, Channel 3
6	LED3	I/O	LED Indication Pin, Channel 3
7	AVSS	—	Field Side Negative Supply
8	IN4	I/O	Field Input, Channel 4
9	LED4	I/O	LED Indication Pin, Channel 4
10	IN5	I/O	Field Input, Channel 5
11	LED5	I/O	LED Indication Pin, Channel 5
12	IN6	I/O	Field Input, Channel 6
13	LED6	I/O	LED Indication Pin, Channel 6
14	IN7	I/O	Field Input, Channel 7
15	LED7	I/O	LED Indication Pin, Channel 7
16	AVCC	—	Field Side Positive Supply
17	AVSS	—	Field Side Negative Supply
18	IN8	I/O	Field Input, Channel 8
19	LED8	I/O	LED Indication Pin, Channel 8
20	NC	—	No Connection
21	GND1	—	Ground
22	NC	—	No Connection
23	F1	—	Field Side Input
24	F0	—	Field Side Input
25	GND1	—	Ground
26	nFAULT	—	Field Side Fault
27	OUT_EN	—	Field Side Output Enable
28	OUT8 / SYNC	—	Field Side Output 8 / Sync
29	OUT7 / BURST_EN	—	Field Side Output 7 / Burst Enable
30	OUT6 / nRST	—	Field Side Output 6 / Reset
31	OUT5 / nINT	—	Field Side Output 5 / Interrupt
32	OUT4 / nCS	—	Field Side Output 4 / Chip Select
33	OUT3 / SCLK	—	Field Side Output 3 / Serial Clock
34	OUT2 / SDI	—	Field Side Output 2 / Serial Data In
35	OUT1 / SDO	—	Field Side Output 1 / Serial Data Out
36	GND1	—	Ground
37	V _{CC1}	—	Field Side Positive Supply
38	COMM_SEL	—	Field Side Communication Select

Table 4-1. Pin Functions—38 Pins (continued)

PIN		I/O	DESCRIPTION
NO.	NAME		
16	AVCC	—	Field Side Power Supply
17	AVSS	—	Field Side Negative Supply
18	IN8	I/O	Field Input, Channel 8
19	LED8	I/O	LED Indication Pin, Channel 8
20	NC	—	Leave unconnected
21	GND1	—	Logic Ground
22	NC	—	Leave unconnected
23	F1	I	Digital Filter Setting
24	F0	I	Digital Filter Setting
25	GND1	—	Logic Ground
26	nFAULT	O	Open Drain Ouput. Connect 4.7 kΩ pull-up to V _{CC1}
27	OUT_EN	I	Ouput Enable. Output pins OUT1 through OUT8 are tri-stated if OUT_EN=0 or FLOAT
28	OUT8/SYNC	O	Synchronize data in Burst Mode(COMM_SEL=V _{CC1}) Data Output, Channel 8, in Parallel Interface Mode (COMM_SEL=0)
29	OUT7/ BURST_EN	I/O	Burst Mode in Serial Interface Mode (COMM_SEL=V _{CC1}) Data Output, Channel 7, in Parallel Interface Mode (COMM_SEL=0)
30	OUT6/nRST	I/O	Active Low SPI Reset in Serial Interface Mode (COMM_SEL=V _{CC1}) Data Output, Channel 6, in Parallel Interface Mode (COMM_SEL=0)
31	OUT5/nINT	O	Active Low SPI Interrupt in Serial Interface Mode (COMM_SEL=V _{CC1}) Data Output, Channel 5, in Parallel Interface Mode (COMM_SEL=0)
32	OUT4/nCS	I/O	SPI Chip Seltect in Serial Interface Mode (COMM_SEL=V _{CC1}) Data Output, Channel 4, in Parallel Interface Mode (COMM_SEL=0)
33	OUT3/SCLK	I/O	SPI Clock in Serial Interface Mode (COMM_SEL=V _{CC1}) Data Output, Channel 3, in Parallel Interface Mode (COMM_SEL=0)
34	OUT2/SDI	I/O	SPI Input Data in Serial Interface Mode (COMM_SEL=V _{CC1}) Data Output, Channel 2, in Parallel Interface Mode (COMM_SEL=0)
35	OUT1/SDO	O	SPI Output Data in Serial Interface Mode (COMM_SEL=V _{CC1}) Data Output, Channel 1, in Parallel Interface Mode (COMM_SEL=0)
36	GND1	—	Logic Ground
37	VCC1	—	Logic Supply
38	COMM_SEL	I	Serial vs. Parallel Interface selection Serial Interface Mode if COMM_SEL=V _{CC1} Parallel Interface Mode if COMM_SEL=0 or Floating

- I = Input, O = Output, I/O = Input/Output
- Connect all AVSS pins on Field side together
- Connect all GND1 pins on backplane/MCU side together

5 Specifications

5.1 Absolute Maximum Ratings

See⁽¹⁾

		MIN	MAX	UNIT
AVCC ⁽²⁾	AVCC to AVSS supply voltage	-0.5	38.5	V
V _{CC1} ⁽²⁾	V _{CC1} supply voltage to GND1	-0.5	6	V
V _{INx}	Voltage from INx pins to AVSS	-0.5	38.5	V
V _{LEDx}	Voltage from LEDx pins to AVSS	-0.5	38.5	V
V _{IO}	I/O voltage range on SDx, nCS, nINT, OUTx, OUT_EN, F0, F1, nFAULT, and COMM_SEL pins	-0.3	V _{CC1} +0.5 ⁽³⁾	V
I _O	Output current on SDO, nINT, OUTx, and nFAULT pins	-15	15	mA
T _J	Operating junction temperature		150	°C
T _{STG}	Storage temperature	-65	150	°C

- (1) Operation outside the Absolute Maximum Ratings may cause permanent device damage. Absolute Maximum Ratings do not imply functional operation of the device at these or any other conditions beyond those listed under Recommended Operating Conditions. If used outside the Recommended Operating Conditions but within the Absolute Maximum Ratings, the device may not be fully functional, and this may affect device reliability, functionality, performance, and shorten the device lifetime.
- (2) All voltage values are with respect to the local ground terminal (AVSS or GND1) and are peak voltage values
- (3) Maximum voltage must not exceed 6 V.

5.2 ESD Ratings

			VALUE	UNIT
V _(ESD)	Electrostatic discharge Human body model (HBM), per ANSI/ESDA/JEDEC JS-001,	All pins ⁽¹⁾	±1000	V
		All INx, LEDx and AVCC to AVSS ⁽¹⁾	±6000	V
V _(ESD)	Electrostatic discharge Charged device model (CDM), per JEDEC specification JESD22-C101	All pins ⁽²⁾	±1500	
V _(ESD_IEC)	IEC ESD System Level Test	Contact discharge per IEC 61000-4-2; Isolation barrier withstand test	±6000	V

- (1) JEDEC document JEP155 states that 500-V HBM allows safe manufacturing with a standard ESD control process.
- (2) JEDEC document JEP157 states that 250-V CDM allows safe manufacturing with a standard ESD control process.

5.3 Recommended Operating Conditions

		MIN	NOM	MAX	UNIT
AVCC	Field-Side Supply Voltage w.r.t. AVSS - Sink Mode	8.5		36	V
AVCC	Field-Side Supply Voltage w.r.t. AVSS - Source Mode	13		36	V
V _{CC1}	Backplane Supply Voltage w.r.t. GND1	1.71		5.5	V
V _{INx} ⁽¹⁾	Voltage on INx w.r.t AVSS	-0.3		36	V
R _{LIM}	Current Limit resistor selector	0		1	kΩ
DR	Data Rate on INx pins	0		1.5	Mbps
T _{UI}	Minimum pulse width at INx pins	667			ns
F _{SCLK}	Maximum SPI clock frequency			25	MHz
T _A	Ambient temperature	-40		125	°C
T _J	Junction temperature	-40		150	°C

(1) V_{INx} can be set independent of AVCC

5.4 Thermal Information

THERMAL METRIC ⁽¹⁾		ISO1228	
		DFB (SSOP)	
		38 PINS	
			UNIT
$R_{\theta JA}$	Junction-to-ambient thermal resistance	91.8	°C/W
$R_{\theta JC(top)}$	Junction-to-case (top) thermal resistance	50.5	°C/W
$R_{\theta JB}$	Junction-to-board thermal resistance	58.2	°C/W
Ψ_{JT}	Junction-to-top characterization parameter	30.3	°C/W
Ψ_{JB}	Junction-to-board characterization parameter	57.7	°C/W
$R_{\theta JC(bot)}$	Junction-to-case (bottom) thermal resistance	—	°C/W

(1) For more information about traditional and new thermal metrics, see the [Semiconductor and IC Package Thermal Metrics application report](#).

5.5 Power Ratings

PARAMETER		TEST CONDITIONS	MIN	TYP	MAX	UNIT
ISO1228						
P_D	Maximum power dissipation (both sides)	$V_{CC} = 24\text{ V}$, $V_{CC1} = 5.5\text{ V}$, $T_J = 150^\circ\text{C}$, $C_L = 15\text{ pF}$, SPI Frequency = 25 MHz, INx = 30 V, $R_{LIM} = 1\text{ k}\Omega$			565	mW
P_{DF}	Maximum power dissipation (Field Side)				535	mW
P_{DL}	Maximum power dissipation (Logic Side)				30	mW

5.6 Insulation Specifications

PARAMETER		TEST CONDITIONS	VALUE	UNIT
			DW-16	
CLR	External clearance ⁽¹⁾	Shortest terminal-to-terminal distance through air	4	mm
CPG	External creepage ⁽¹⁾	Shortest terminal-to-terminal distance across the package surface	4	mm
DTI	Distance through the insulation	Minimum internal gap (internal clearance)	>17	um
CTI	Comparative tracking index	DIN EN 60112 (VDE 0303-11); IEC 60112	>400	V
	Material group	According to IEC 60664-1	II	
	Overvoltage category per IEC 60664-1	Rated mains voltage ≤ 150 V _{RMS}	I-IV	
	Overvoltage category per IEC 60664-1	Rated mains voltage ≤ 300 V _{RMS}	I-III	
DIN EN IEC 60747-17 (VDE 0884-17) ⁽²⁾				
V _{IORM}	Maximum repetitive peak isolation voltage	AC voltage (bipolar)	637	V _{PK}
V _{IOWM}	Maximum working isolation voltage	AC voltage; Time dependent dielectric breakdown (TDDDB) Test;	450	V _{RMS}
		DC voltage	637	V _{DC}
V _{IOTM}	Maximum transient isolation voltage	V _{TEST} = V _{IOTM} , t = 60 s (qualification); V _{TEST} = 1.2 x V _{IOTM} , t = 1 s (100% production)	4242	V _{PK}
V _{IMP}	Maximum impulse voltage ⁽³⁾	Tested in air, 1.2/50-us waveform per IEC 62368-1	4000	V _{PK}
V _{IOSM}	Maximum surge isolation voltage ⁽⁴⁾	V _{IOSM} ≥ 1.3 x V _{IMP} ; Tested in oil (qualification test), 1.2/50-μs waveform per IEC 62368-1	5200	V _{PK}
q _{pd}	Apparent charge ⁽⁵⁾	Method a, After Input-output safety test subgroup 2/3, V _{ini} = V _{IOTM} , t _{ini} = 60 s; V _{pd(m)} = 1.2 x V _{IORM} , t _m = 10 s	≤5	pC
		Method a, After environmental tests subgroup 1, V _{ini} = V _{IOTM} , t _{ini} = 60 s; V _{pd(m)} = 1.2 x V _{IORM} , t _m = 10 s	≤5	
		Method b: At routine test (100% production); V _{ini} = 1.2 x V _{IOTM} , t _{ini} = 1 s; V _{pd(m)} = 1.5 x V _{IORM} , t _m = 1 s (method b1) or V _{pd(m)} = V _{ini} , t _m = t _{ini} (method b2)	≤5	
C _{IO}	Barrier capacitance, input to output ⁽⁶⁾	V _{IO} = 0.4 x sin(2πft), f = 1 MHz	~0.5	pF
R _{IO}	Isolation resistance ⁽⁶⁾	V _{IO} = 500 V, T _A = 25°C	> 10 ¹²	Ω
		V _{IO} = 500 V, 100°C ≤ T _A ≤ 125°C	> 10 ¹¹	
		V _{IO} = 500 V at T _S = 150°C	> 10 ⁹	
	Pollution degree		2	
	Climatic category		40/125/21	
UL 1577				
V _{ISO}	Maximum withstanding isolation voltage	V _{TEST} = V _{ISO} , t = 60 s (qualification), V _{TEST} = 1.2 x V _{ISO} , t = 1 s (100% production)	3000	V _{RMS}

- (1) Creepage and clearance requirements should be applied according to the specific equipment isolation standards of an application. Care should be taken to maintain the creepage and clearance distance of a board design to ensure that the mounting pads of the isolator on the printed-circuit board do not reduce this distance. Creepage and clearance on a printed-circuit board become equal in certain cases. Techniques such as inserting grooves and/or ribs on a printed-circuit board are used to help increase these specifications.
- (2) This isolated digital input is suitable for *basic electrical insulation* only within the safety ratings. Compliance with the safety ratings shall be ensured by means of suitable protective circuits.
- (3) Testing is carried out in air to determine the surge immunity of the package.
- (4) Testing is carried out in oil to determine the intrinsic surge immunity of the isolation barrier.
- (5) Apparent charge is electrical discharge caused by a partial discharge (pd).
- (6) All pins on each side of the barrier tied together creating a two-terminal device.

5.7 Safety-Related Certifications

VDE	CSA	UL	CQC	TUV
Plan to certify according to DIN EN IEC 60747-17 (VDE 0884-17)	Certified according to IEC 62368-1 and IEC 61010-1	Plan to certify according to UL 1577 Component Recognition Program	Plan to certify according to GB4943.1	Plan to certify according to EN 61010-1 and EN 62368-1
Maximum transient isolation voltage, 4242 V _{PK} ; Maximum repetitive peak isolation voltage, 637 V _{PK} ; Maximum surge isolation voltage, 5200 V _{PK}	3000 V _{RMS} Basic Insulation Working voltage of 400 V _{RMS} per IEC / CSA / EN 62368-1 and 300 V _{RMS} per IEC / CSA 61010-1	Single protection, 3000 V _{RMS}	Basic insulation, Altitude ≤ 5000 m, Tropical Climate, 250 V _{RMS} maximum working voltage	3000 V _{RMS} Basic Insulation per EN 61010-1 up to working voltage of 300 V _{RMS} and EN 62368-1 up to working voltage of 400 V _{RMS} .
Certificate planned	Certificate planned	Certificate planned	Certificate planned	Certificate planned

5.8 Safety Limiting Values

Safety limiting⁽¹⁾ intends to minimize potential damage to the isolation barrier upon failure of input or output circuitry.

PARAMETER		TEST CONDITIONS	MIN	TYP	MAX	UNIT
D-38 PACKAGE						
I _S	Safety input, output, or supply current - Backplane side ⁽¹⁾	R _{θJA} = 91.8°C/W, V _{CC1} = 5.5 V, T _J = 150°C, T _A = 25°C			248	mA
I _S	Safety input, output, or supply current - Field side ⁽¹⁾	R _{θJA} = 91.8°C/W, AVCC = 36V, T _J = 150°C, T _A = 25°C			38	mA
P _S	Safety input, output, or total power ⁽¹⁾	R _{θJA} = 91.8°C/W, T _J = 150°C, T _A = 25°C			1362	mW
T _S	Maximum safety temperature ⁽¹⁾				150	°C

- (1) The maximum safety temperature, T_S, has the same value as the maximum junction temperature, T_J, specified for the device. The I_S and P_S parameters represent the safety current and safety power respectively. The maximum limits of I_S and P_S should not be exceeded. These limits vary with the ambient temperature, T_A.
The junction-to-air thermal resistance, R_{θJA}, in the table is that of a device installed on a high-K test board for leaded surface-mount packages. Use these equations to calculate the value for each parameter:
T_J = T_A + R_{θJA} × P, where P is the power dissipated in the device.
T_{J(max)} = T_S = T_A + R_{θJA} × P_S, where T_{J(max)} is the maximum allowed junction temperature.
P_S = I_S × V_I, where V_I is the maximum input voltage.

5.9 Electrical Characteristics—DC Specification

(Over recommended operating conditions unless otherwise noted).

PARAMETER		TEST CONDITIONS	MIN	TYP	MAX	UNIT
SUPPLY VOLTAGE AND CURRENT						
AVCC (UVLO+)	Positive-going UVLO threshold voltage - Sink Mode			7.7	8.4	
AVCC (UVLO-)	Negative-going UVLO threshold - Sink Mode		5.5	6		
AVCC (UVLO+)	Positive-going UVLO threshold voltage - Source Mode			11.7	12.5	
AVCC (UVLO-)	Negative-going UVLO threshold - Source Mode		9	9.8		
AVCC (HYS)	UVLO threshold hysteresis			1.7		
V _{CC1} (UVLO+)	Positive-going UVLO threshold voltage (V _{CC1})			1.53	1.71	V
V _{CC1} (UVLO-)	Negative-going UVLO threshold (V _{CC1})		1.3	1.41		V
V _{CC1} (HYS)	UVLO threshold hysteresis (V _{CC1})		0.08	0.13		V
I _{AVCC} (SINK)	AVCC supply quiescent current	INx=HIGH or LOW DC		3.5	5	mA
I _{AVCC} (SRC)	AVCC supply quiescent current in source mode	INx=HIGH or LOW DC		4.5	5.8	mA
I _{VCC1}	V _{CC1} supply disable current	INx=HIGH or LOW DC, OUT_EN = LOW or FLOAT		.3	.8	mA
I _{VCC1}	V _{CC1} supply quiescent current	INx=HIGH or LOW DC, OUT_EN = V _{CC1}		3.5	4.3	mA
LOGIC I/O						
V _{IT+} (EN)	Positive-going input logic threshold voltage for OUT_EN, SDI, SCLK, COMM_SEL and nCS pins				0.7 × V _{CC1}	V
V _{IT-} (EN)	Negative-going input logic threshold voltage for OUT_EN, SDI, SCLK, COMM_SEL and nCS pins		0.3 × V _{CC1}			V
V _{HYS} (EN)	Input hysteresis voltage for OUT_EN, SDI, SCLK, COMM_SEL and nCS pins			0.15 × V _{CC1}		V
I _{IL}	Low-level input for SDI, SCLK, nRST, BURST_EN and nCS pins	OUT_EN = V _{CC1} and COMM_SEL = V _{CC1}	-15			μA
I _{IL}	Low-level input for OUT_EN		-30			μA
I _{IH}	High-level input for SDI, SCLK, COMM_SEL, nRST, BURST_EN and nCS pins	OUT_EN = V _{CC1} and COMM_SEL = V _{CC1}			15	μA
I _{IH}	High-level input for OUT_EN				30	μA
V _{OH}	High-level output voltage on OUTx and SDO pins.	V _{CC1} = 1.71 V; I _{OH} = -1 mA	V _{CC1} - 0.2			V
V _{OL}	Low-level output voltage on OUTx, SDO, nINT and nFAULT pins	V _{CC1} = 1.71 V; I _{OH} = 1 mA			0.2	V
CURRENT LIMIT AND WIRE-BREAK						
I _{INx} + I(R _{PARx})	Sum of Current drawn through INx pins and corresponding R _{PAR} external resistor (Sink Type)	R _{THR} = 0 Ω, R _{ILIM} = 0 kΩ V _{IL} < V _{INx} < V _{IH}		2	3.3	mA
I _{INx} + I(R _{PARx})	Sum of Current drawn through INx pins and corresponding R _{PAR} external resistor (Sink Type)	R _{THR} = 0 Ω, R _{ILIM} = 0kΩ V _{IH} < V _{INx} < 36		2.1	3.3	mA
I _{INx} + I(R _{PARx})	Sum of Current drawn through INx pins and corresponding R _{PAR} external resistor (Sink Type)	R _{THR} = 0 Ω, R _{ILIM} = 1 kΩ V _{IL} < V _{INx} < V _{IH}		3	4.7	mA
		R _{THR} = 0 Ω, R _{ILIM} = 1 kΩ V _{IH} < V _{INx} < 36 V		3.1	4.7	

(Over recommended operating conditions unless otherwise noted).

PARAMETER		TEST CONDITIONS	MIN	TYP	MAX	UNIT
$I_{INx} + I(R_{PARx})$	Sum of Current drawn through INx pins and corresponding R_{PAR} external resistor (Source Type)	$R_{THR} = 0 \Omega$, $R_{ILIM} = 1 \text{ k}\Omega$ $V_{IL} < AVCC - V_{INx} < V_{IH}$	3		4.2	mA
		$R_{THR} = 0 \Omega$, $R_{ILIM} = 1 \text{ k}\Omega$ $V_{IH} < AVCC - V_{INx} < 36 \text{ V}$	3.1		4.2	
$I_{INx} + I(R_{PARx})$	Sum of Current drawn through INx pins and corresponding R_{PAR} external resistor (Source Type)	$R_{THR} = 0 \Omega$, $R_{ILIM} = 0 \Omega$ $V_{IL} < AVCC - V_{INx} < V_{IH}$	2		3.3	mA
$I_{INx} + I(R_{PARx})$	Sum of Current drawn through INx pins and corresponding R_{PAR} external resistor (Source Type)	$R_{THR} = 0 \Omega$, $R_{ILIM} = 0 \Omega$ $V_{IH} < AVCC - V_{INx} < 36 \text{ V}$	2.1		3.3	mA
I_{WB}	Wire-break Detection Threshold	$R_{IWB}^{(1)} = 90 \text{ k}\Omega$			245	μA
$I_{INx(UVLO)}$	Sum of Current drawn through INx pins and corresponding R_{PAR} external resistor (Sink Type) when AVCC is not present.	$R_{ILIM} = 1 \text{ k}\Omega$, $R_{THR} = 0 \Omega$, $R_{PAR} = 9.76 \text{ k}\Omega$ $V_{INx} = 13 \text{ V}$	1			mA

(Over recommended operating conditions unless otherwise noted).

PARAMETER		TEST CONDITIONS	MIN	TYP	MAX	UNIT
VOLTAGE TRANSITION THRESHOLD ON FIELD SIDE						
V _{IL}	Low level threshold voltage at module input (including R _{THR}) for output low. Sink Type.	R _{ILIM} = 1 kΩ or 0 Ω, R _{THR} = 0 Ω	4.7			V
		R _{ILIM} = 1 kΩ, R _{THR} = 1 kΩ	7.7			
V _{IL}	Low level threshold voltage at module input (including R _{THR}) for output low. Sink Type.	R _{ILIM} = 0 Ω, R _{THR} = 1 kΩ	6.7			V
V _{IH}	High level threshold voltage at module input (including R _{THR}) for output high. Sink Type.	R _{ILIM} = 1 kΩ or 0 Ω, R _{THR} = 0 Ω			6.4	V
		R _{ILIM} = 1 kΩ, R _{THR} = 1 kΩ			11.1	
		R _{ILIM} = 0 Ω, R _{THR} = 1 kΩ			9.7	
V _{HYS}	Threshold voltage hysteresis at module input. Sink Type.	R _{ILIM} = 1 kΩ, R _{THR} = 0 Ω	0.85	1		V
		R _{ILIM} = 1 kΩ, R _{THR} = 1 kΩ	0.8	1		
		R _{ILIM} = 0 Ω, R _{THR} = 1 kΩ	0.7	1		
AVCC-V _{IL}	Low level threshold voltage at module input (including R _{THR}) for output low. Source Type.	R _{ILIM} = 0 Ω, R _{THR} = 1.35k Ω	7.4			V
		R _{ILIM} = 1 kΩ, R _{THR} = 2 kΩ	10.7			V
AVCC-V _{IH}	High level threshold voltage at module input (including R _{THR}) for output high. Source Type.	R _{ILIM} = 0 Ω, R _{THR} = 1.35k Ω			10.9	V
		R _{ILIM} = 1 kΩ, R _{THR} = 2 kΩ			14.8	V
V _{HYS}	Threshold voltage hysteresis at module input. Source Type.	R _{ILIM} = 1 kΩ, R _{THR} = 2 kΩ	0.5			V
		R _{ILIM} = 0 Ω, R _{THR} = 1.35k Ω	0.75	1		V
OVER-TEMPERATURE AND THERMAL SHUTDOWN						
OTI	Over-temperature indication without shutdown (No blocks are shut down)		130	142	150	°C
TSD+	Thermal shutdown turn-on temperature (Field Inputs are tri-stated)		160	180	190	°C
TSD-	Thermal shutdown turn-off temperature		155	170	180	°C
TSD _{HYS}	Thermal shutdown hysteresis			5		°C

(1) R_{IWB} is the wire break resistance calculated from the equation, R_{IWB} = (V_{INX} - 2V) / I_{IWB} - R_{THR}

5.10 Switching Characteristics—AC Specification

(Over recommended operating conditions unless otherwise noted).

PARAMETER		TEST CONDITIONS	MIN	TYP	MAX	UNIT
POWER-UP TIMING						
T _{PWRUP}	Time taken for the device to power up, and start communication after V _{CC1} and AVCC are above their UVLO levels.	V _{CC1} and AVCC are ramped up together.		140	200	μs
T _{FILTAVCC}	Internal de-glitch filter on AVCC	AVCC supply dip to corresponding UVLO-thresholds with 10 ns rise/fall times.	3	5	7	μs
T _{FILTCC1}	Internal de-glitch filter on V _{CC1} - recovery time	V _{CC1} supply dip to UVLO- thresholds with 10 ns rise/fall times upto 9us. Time needed by device to be functional again	1	4	7	μs
PROPAGATION DELAY AND CMTI						
t _r , t _f	Output signal rise and fall time, OUTx pins	C _{LOAD} = 15 pF, 24-V _{P-P} clock signal on IN pin with 10-ns rise and fall time, R _{THR} = 0 Ω. Parallel output mode. F1=low, F0=low; Filter Register setting: 0xxx		3		ns

(Over recommended operating conditions unless otherwise noted).

PARAMETER		TEST CONDITIONS	MIN	TYP	MAX	UNIT
t_{PLH}	Propagation delay time for low to high transition	24- V_{PK-PK} clock signal on IN pin with 10-ns rise and fall time, $R_{THR} = 0 \Omega$. Parallel output mode. F1=low, F0=low; Filter Register setting: 0xxx			780	ns
t_{PHL}	Propagation delay time for high to low transition	24- V_{P-P} clock signal on IN pin with 10-ns rise and fall time, $R_{THR} = 0 \Omega$. Parallel output mode. F1=low, F0=low; Filter Register setting: 0xxx			900	ns
$t_{sk(p)}$	Pulse skew $ t_{PHL} - t_{PLH} $	24- V_{P-P} clock signal on IN pin with 10-ns rise and fall time, $R_{THR} = 0 \Omega$. Parallel output mode.			335	ns
t_{UI}	Minimum pulse width	Parallel output mode. F1=low, F0=low; Filter Register setting: 0xxx	660			ns
t_{PHZ}	Disable propagation delay, high-to-high impedance output	$V_{IN} = 24 V$, Pull down resistor of 1k Ω on OUTx. Parallel output mode		30	65	ns
t_{PLZ}	Disable propagation delay, low-to-high impedance output	$V_{IN} = 0 V$, Pull up resistor of 1k Ω on OUTx. Parallel output mode		30	60	ns
t_{PZH}	Enable propagation delay, high impedance-to-high output	$V_{IN} = 24 V$, Pull down resistor of 1k Ω on OUTx. Parallel output mode		3	5	μs
t_{PZL}	Enable propagation delay, high impedance-to-low output	$V_{IN} = 0 V$, Pull up resistor of 1k Ω on OUTx. Parallel output mode		1.5	2.6	μs
CMTI	Common mode transient immunity	F1=low, F0=low; Filter Register setting: 0xxx	50	75		kV/ μs
DIGITAL LOW PASS FILTER						
TFILT	Input Digital Low Pass Filter Averaging Time	F1=low, F0=low; Filter Register setting: 0xxx	0			ns
		F1=low, F0=float; Filter Register setting: 1000	1			μs
		F1=low, F0=high; Filter Register setting: 1001	8			μs
		F1=float, F0=low; Filter Register setting: 1010	200			μs
		F1=float, F0=float; Filter Register setting: 1011	1			ms
		F1=float, F0=high; Filter Register setting: 1100	2.5			ms
		F1=high, F0=low; Filter Register setting: 1101	10			ms
		F1=high, F0=float; Filter Register setting: 1110	30			ms
		F1=high, F0=high; Filter Register setting: 1111	100			ms
TFILT _{WB}	Input Filter for Wire-break Detection			30		ms
SPI TIMING - 2.25 V to 5.5 V						
FSCLK	SCLK Frequency, $V_{CC1} = 2.25 V$ to 5.5 V			25		MHz
TSCLK	SCLK Bit Period		40			ns
TSCLKH	SCLK High Pulse Width		20			ns
TSCLKL	SCLK Low Pulse Width		20			ns
TDO	SCLK output to SDO valid		4.5		12.5	ns
TCSW	Chip Select 'High' Pulse Width		250			ns

(Over recommended operating conditions unless otherwise noted).

PARAMETER		TEST CONDITIONS	MIN	TYP	MAX	UNIT
TCCLK	Time from nCS low to SCLK first rising edge		20			ns
TCLKCS	Time from SCLK last falling edge to nCS high		10			ns
TCSDOV	Time from nCS low to SDO first data valid				10	ns
TCSDOZ	Time from nCS high to SDO hi-Z				15	ns
TSDISU	Setup time SDI to SCLK rising edge		10			ns
TSDIH	Hold time SCLK rising edge to SDI		10			ns
TFLTW	nFAULT min low time after last fault de-assertion (unless fault register read)		9			µs
TSRSTNCS	Time from nSRST high (de-assertion) to CS low (assertion)		150			ns
SPI TIMING - 1.71 V to 2.25 V						
FCLK	SCLK Frequency, $V_{CC1} = 1.71 \text{ V to } 2.25 \text{ V}$				15	MHz
TSCLK	SCLK Bit Period		66.67			ns
TSCLKH	SCLK High Pulse Width		33.33			ns
TSCLKL	SCLK Low Pulse Width		33.33			ns
TDO	SCLK output to SDO valid		7		21.5	ns
TCSW	Chip Select 'High' Pulse Width		390			ns
TCCLK	Time from nCS low to SCLK first rising edge		20			ns
TCLKCS	Time from SCLK last falling edge to nCS high		10			ns
TCSDOV	Time from nCS low to SDO first data valid				20	ns
TCSDOZ	Time from nCS high to SDO hi-Z				20	ns
TSDISU	Setup time SDI to SCLK rising edge		10			ns
TSDIH	Hold time SCLK rising edge to SDI		10			ns
TFLTW	nFAULT min low time after last fault de-assertion (unless fault register read)		9			µs
TSRSTNCS	Time from nSRST high (de-assertion) to CS low (assertion)		200			ns
TCOMMSEL1	Time from COMM_SEL low to high to first valid nCS		300			ns
TCOMMSEL2	Time from COMM_SEL high to low to valid OUTx				60	ns

5.11 Typical Characteristics

The following conditions apply (unless otherwise noted) : $R_{PAR} = 13\text{ k}\Omega$ when $R_{ILIM} = 0\text{ k}\Omega$, $R_{PAR} = 9.76\text{ k}\Omega$ when $R_{ILIM} = 1\text{ k}\Omega$, $R_{SURGE} = 0\text{ k}\Omega$, $AVCC = 24\text{V}$, $T_A = 27\text{ }^\circ\text{C}$, $V_{LEDx} = 1.8\text{V}$,

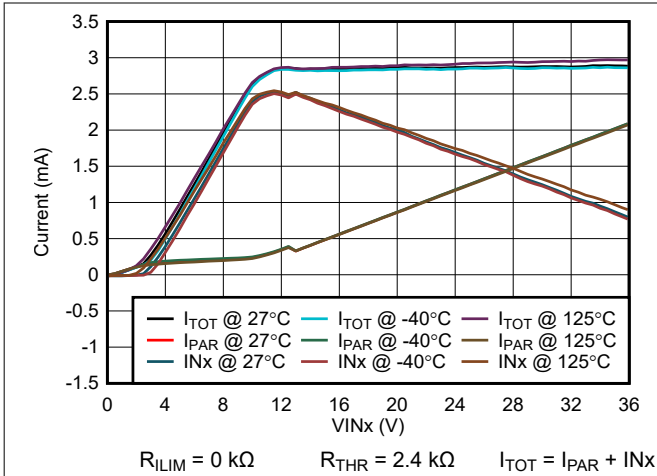

Figure 5-1. Input Current vs Input Voltage in Sink Mode

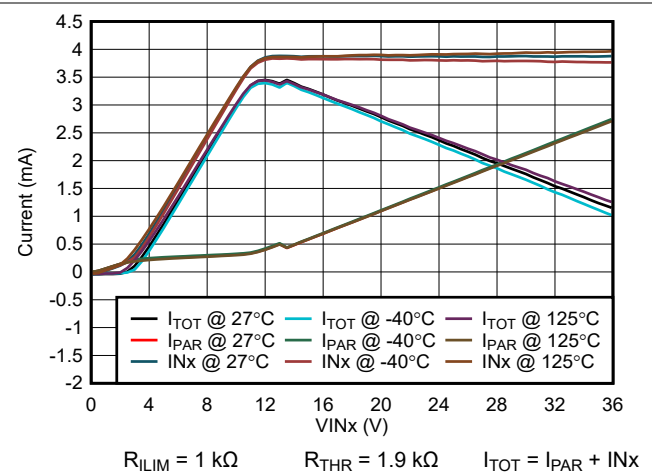

Figure 5-2. Input Current vs Input Voltage in Sink Mode

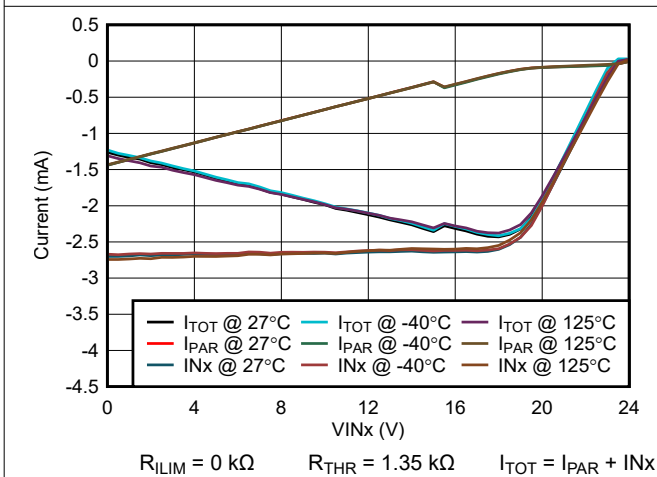

Figure 5-3. Input Current vs Input Voltage in Source Mode

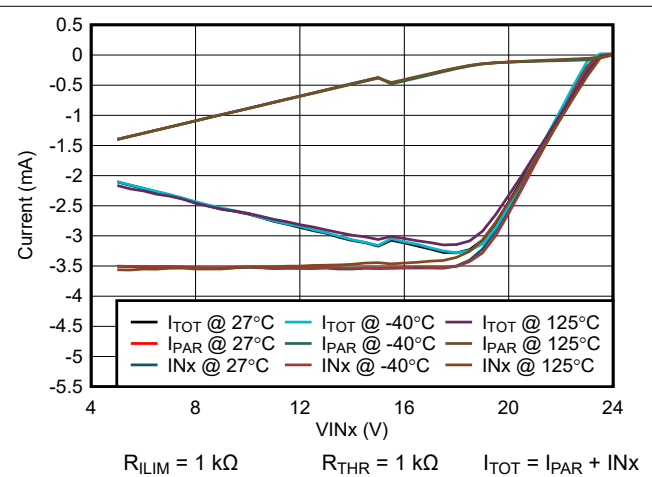

Figure 5-4. Input Current vs Input Voltage in Source Mode

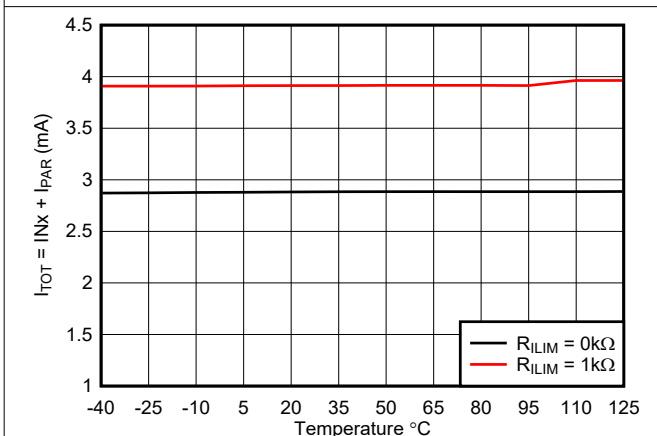

Figure 5-5. Input Current vs Temperature in Sink Mode

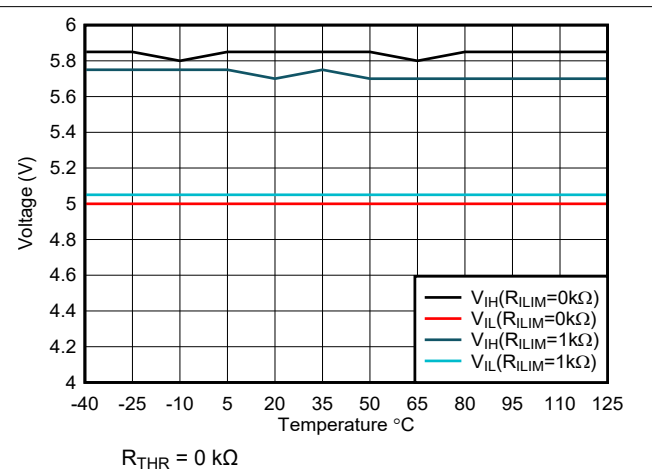

Figure 5-6. Input Voltage Threshold vs Temperature in Sink Mode

5.11 Typical Characteristics (continued)

The following conditions apply (unless otherwise noted) : $R_{PAR} = 13\text{ k}\Omega$ when $R_{LILIM} = 0\text{ k}\Omega$, $R_{PAR} = 9.76\text{ k}\Omega$ when $R_{LILIM} = 1\text{ k}\Omega$, $R_{SURGE} = 0\text{ k}\Omega$, $AVCC = 24\text{V}$, $T_A = 27\text{ }^\circ\text{C}$, $V_{LEDx} = 1.8\text{V}$,

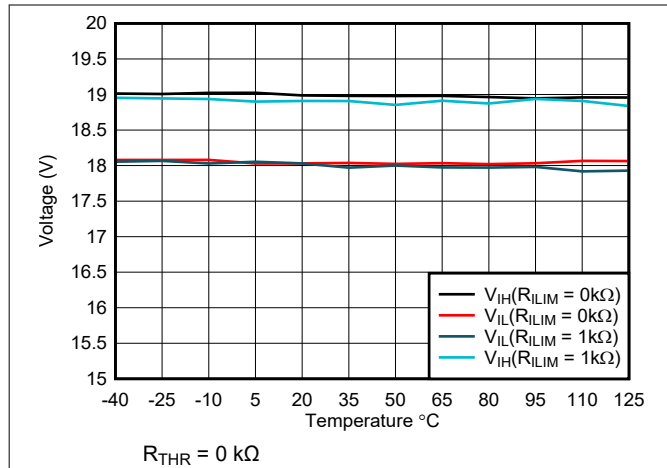

Figure 5-7. Input Voltage Threshold vs Temperature in Source Mode

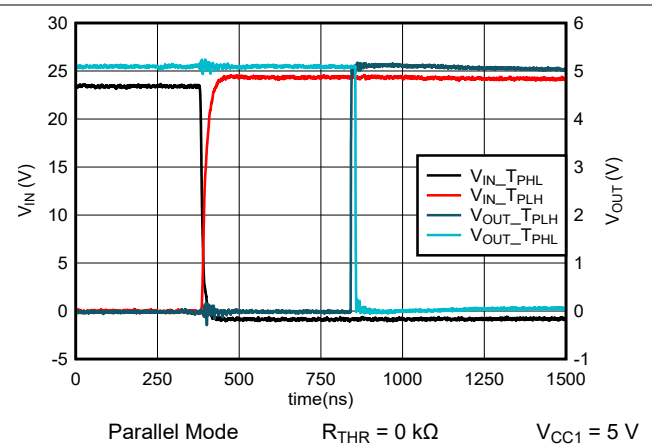

Figure 5-8. Propagation delay

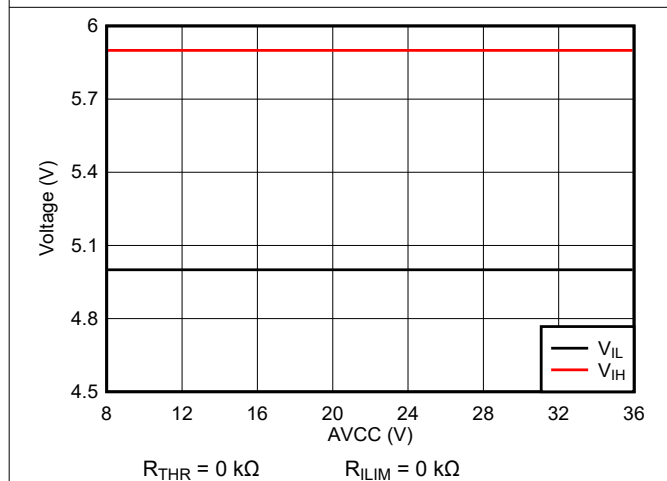

Figure 5-9. Input Voltage Threshold vs AVCC in Sink Mode

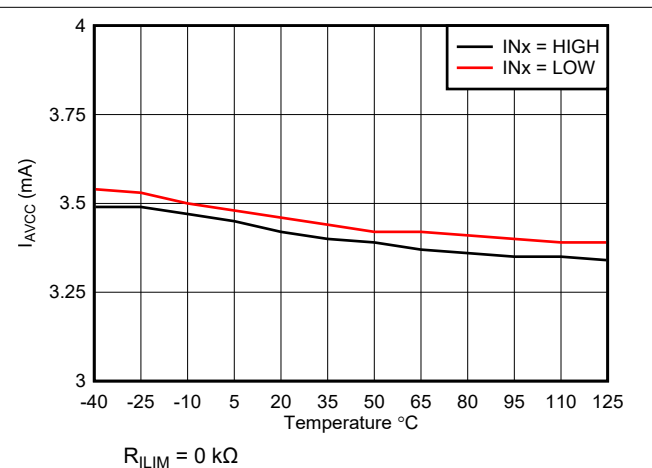

Figure 5-10. Supply Current vs Temperature in Sink Mode

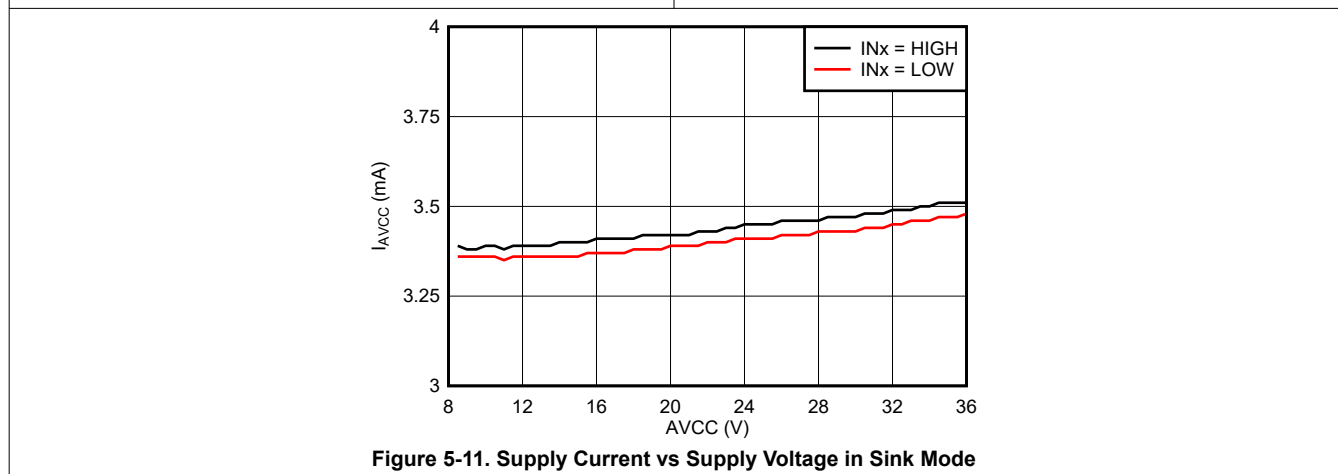

Figure 5-11. Supply Current vs Supply Voltage in Sink Mode

6 Parameter Measurement Information

6.1 Test Circuits

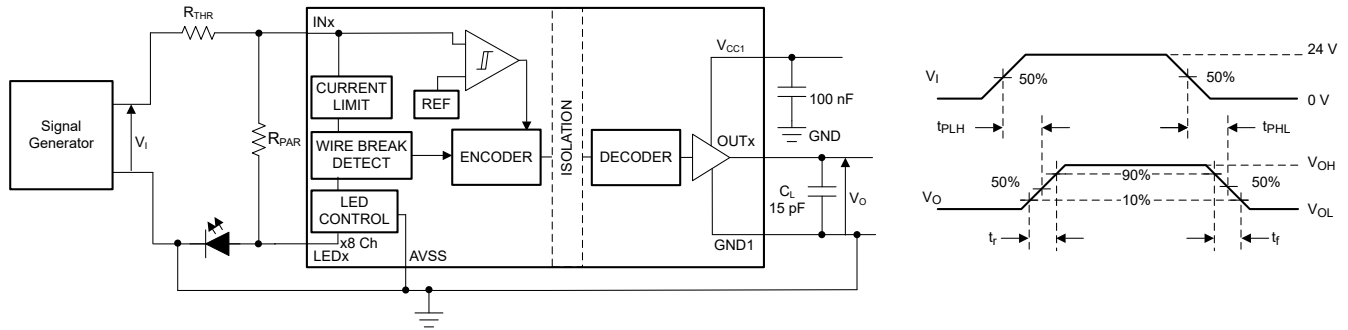

Figure 6-1. Switching Characteristics Test Circuit and Voltage Waveforms

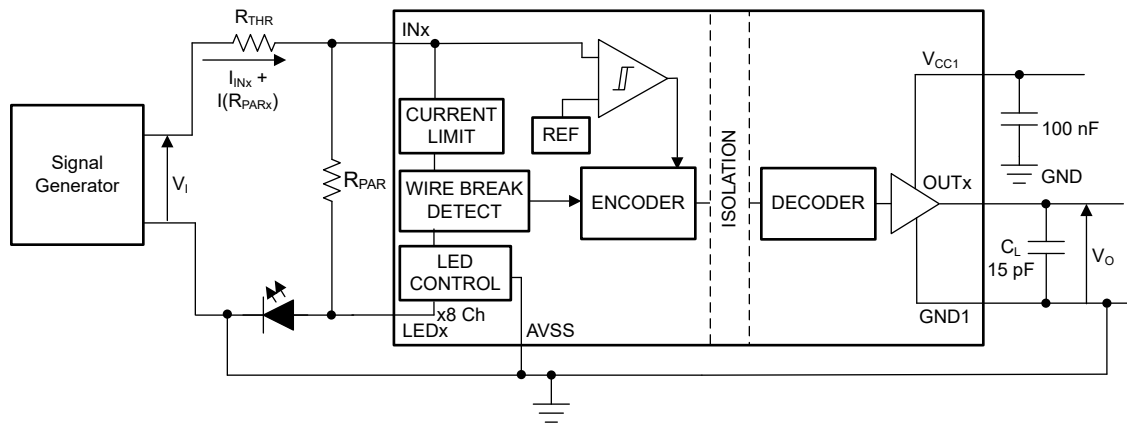

Figure 6-2. Input Current and Voltage Threshold Test Circuit

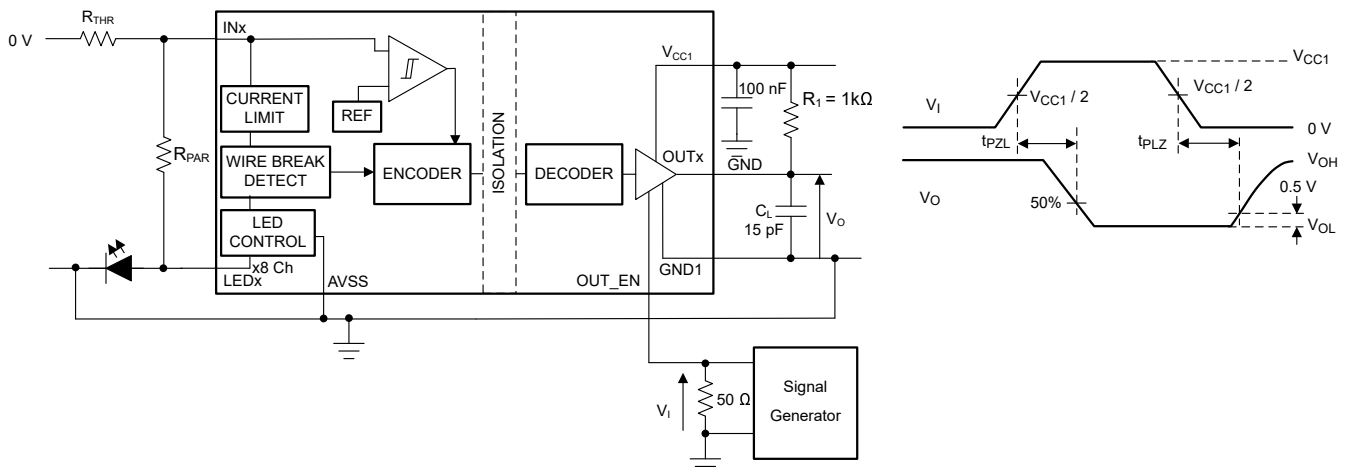

Figure 6-3. Enable and Disable Propagation Delay Time Test Circuit and Waveform—Logic Low State

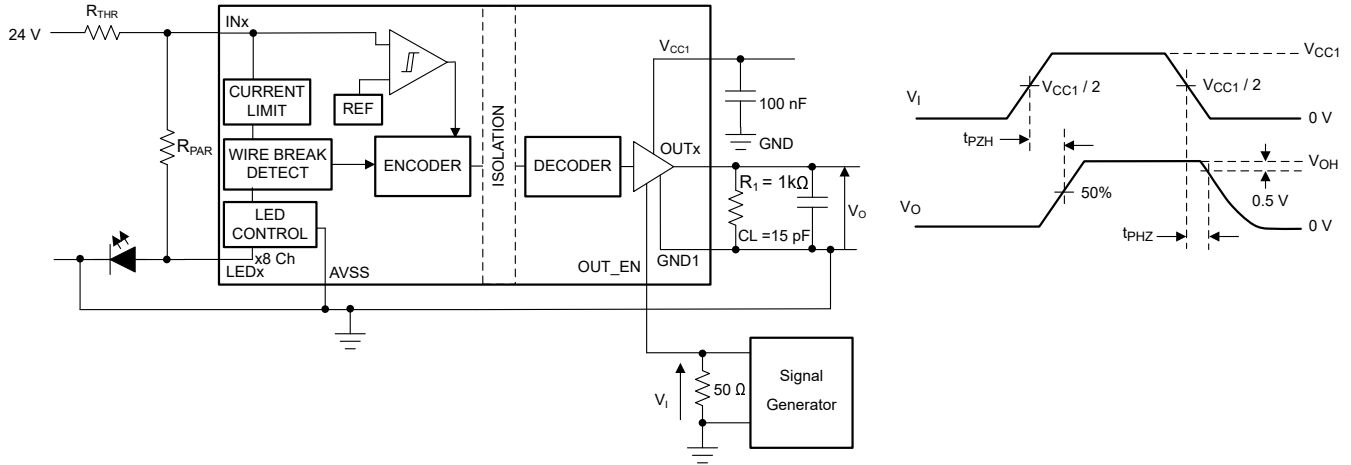
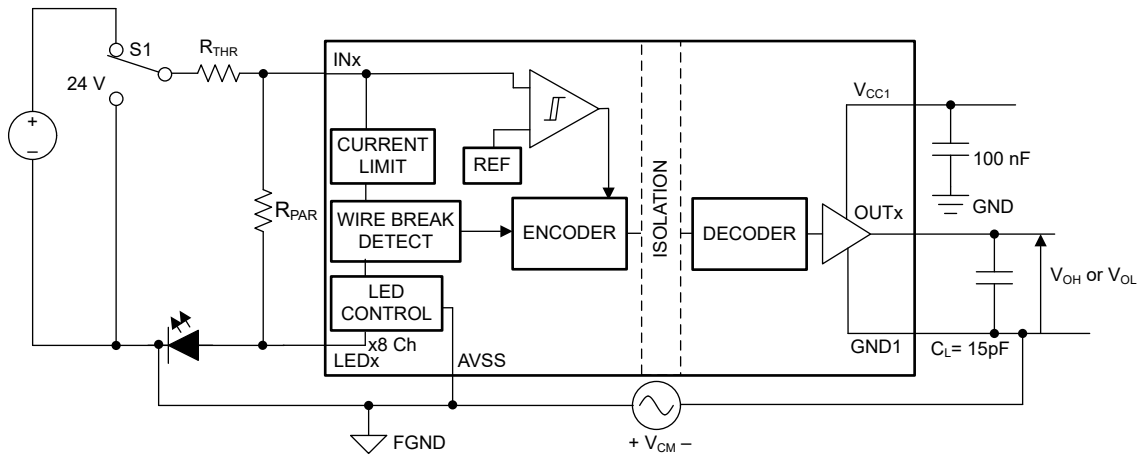

Figure 6-4. Enable and Disable Propagation Delay Time Test Circuit and Waveform—Logic High State



A. Pass Criterion: The output must remain stable.

Figure 6-5. Common-Mode Transient Immunity Test Circuit

7 Detailed Description

7.1 Overview

The ISO1228 device is an eight channel fully-integrated, isolated digital-input receiver with IEC 61131-2 Type 1, 2, and 3 characteristics. The device receives 0V to 36V digital-input signals and provides isolated digital outputs on MCU/backplane side. An external resistor, R_{LIM} , in the AVCC supply path, precisely sets the limit for the current drawn from each digital input. The current limit is common to all channels. Resistors R_{PAR} must be included between each IN_x and the corresponding LED_x pins to have a flat current limit feature. The voltage transition thresholds are compliant with Type 1, 2, and 3 and can be increased further using external resistors, R_{THR} . For more information on selecting the R_{LIM} , R_{SURGE} , R_{PAR} and R_{THR} resistor values, see the [Detailed Design Procedure](#) section. The current drawn from the digital inputs is diverted to LED_x pins, once the digital input crosses the input voltage threshold. This feature allows field-side LED indication with no additional power consumption. ISO1228 can be configured for either sinking or sourcing type digital inputs.

The ISO1228 serializes data from all eight digital inputs and transfers the data across the isolation barrier. The device supports wire-break detection, field side supply monitoring, and internal CRC for across barrier communication. The device can be used in parallel output or serial (SPI) modes.

The ISO1228 supports a wide supply voltage range of 1.71V to 5.5V on the logic side. The conceptual block diagram of the ISO1228 is shown in the [Functional Block Diagram](#) section.

7.2 Functional Block Diagram

A simplified functional block diagram of ISO1228 is shown below.

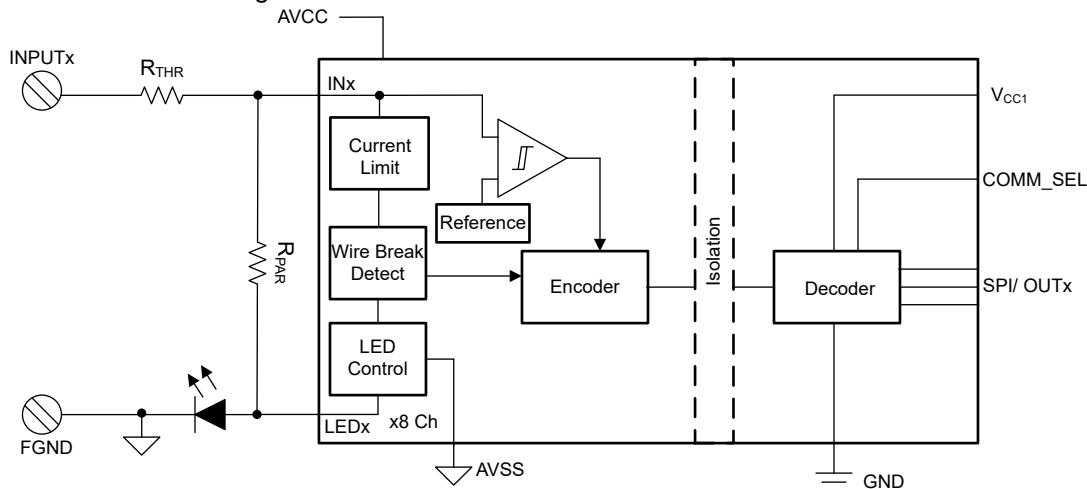

Figure 7-1. Sink Type

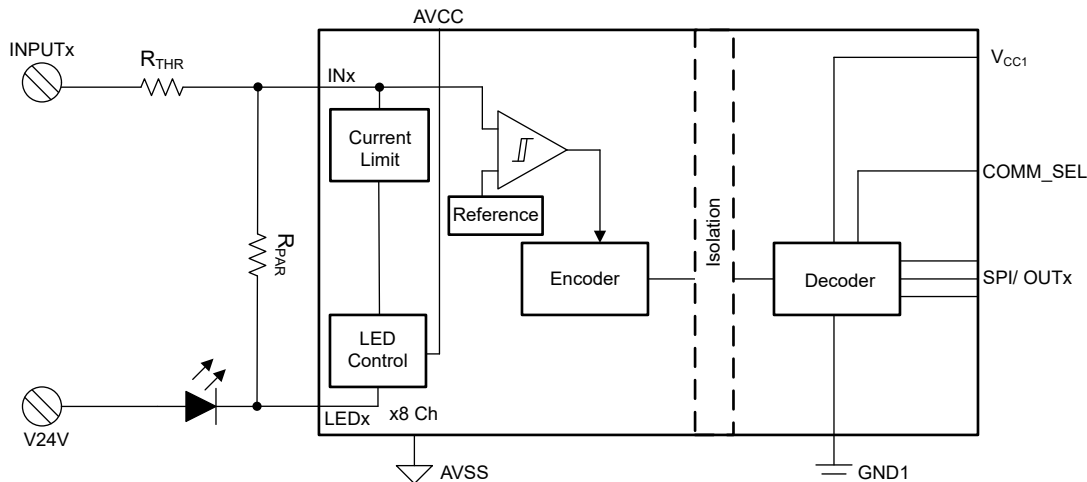

Figure 7-2. Source Type

7.3 Feature Description

The ISO1228 devices receive digital input signals up to 36V and provide serialized or parallel digital outputs. An external resistor, R_{LIM} and external capacitor C_{FIL} , connected in the AVCC or AVSS path, sets the limit for the current drawn from the field input. The external R_{THR} resistors set the input-voltage transition thresholds. The resistor also protects the inputs from Surge events if surge-proof resistors are used.

The internal voltage comparator on the LED1 to LED8 pins selects the sinking or the sourcing type input. The direction of all LEDs needs to be the same and connected to the same voltage to detect sinking or sourcing type input otherwise, the Field side does not power up.

7.3.1 Surge Protection

INx and AVCC have surge protection with an external surge-proof / pulse load resistor. 500 Ω , 1k Ω , and 2k Ω surge-proof / pulse load resistors can protect against surges of 500V/42 Ω , 1.2/50 μ s, 1kV/42 Ω , 1.2/50 μ s, 2kV/42 Ω , 1.2/50 μ s respectively without the need of an external TVS diode in Sink Mode. The surge-proof / pulse load resistor should be able to withstand the dissipation of the surge energy. R_{LIM} and R_{SURGE} together protect against surge events on AVCC and AVSS pins in Sink Mode. R_{THR} protects against surge events on Field Inputs when surge-proof resistors such as MELF resistors are used. R_{PAR} doesn't need to be a surge-proof resistor. Source Mode will require TVS diodes for surge protection.

7.3.2 Field Side LED Indication

ISO1228 supports field side LED indication. The current through INx and R_{PAR} is diverted to the LEDx pins once the voltage transition threshold V_{IH} is exceeded on INx pins. The LEDs are thus powered by the digital input current, which saves system power dissipation. Similarly, once the INx voltage reduces below V_{IL} , the LEDx pins are bypassed by internal switches shutting the LED off. The use of LED indication is optional. The LEDx pins can be connected directly to GND in sink mode provided wire-break detection is not used and V24V in source mode.

7.3.3 Serial and Parallel Output option

The ISO1228 device supports both parallel and serial output options based on the pin COMM_SEL. If COMM_SEL is high, the device operates in serial mode, and if COMM_SEL is low, in parallel mode. Serial mode is useful in applications where the MCU has only a limited number of pins, whereas parallel mode is used for obtaining the highest data throughput.

Serial mode is supported through SPI. Daisy chaining is also supported. The interrupt pin nINT goes low whenever the INx data changes. This feature saves MCU compute power by obviating the need for continuous SPI reads.

7.3.4 Cyclic Redundancy Check (CRC)

ISO1228 has a cyclic redundancy check that looks for errors in data communication across the isolation barrier. Six-bit CRC is implemented internal to ISO1228. Detection of CRC error results in nFAULT flag being asserted. The corresponding bit in the SPI register is also made high. In case of CRC error, the previous OUTx data is retained till the next successful communication occurs across barrier.

7.3.5 FAULT Indication

ISO1228 monitors the following fault conditions: Power Loss Detection on the field side, Over Temperature Detection and Thermal Shut Down on the field side, Wire-Break detection on any input channel, and CRC failure in serial communication across the isolation barrier. Upon detection of any fault, the corresponding bit in the SPI register is made high. Similarly, any fault detection will be flagged on the nFAULT pin (active low). Ignore the nFAULT pin and the data in the SPI registers till 25ms after power up. The fault status in the SPI register is maintained till the fault register is read, provided the underlying fault condition is resolved. nFAULT pin is asserted for at least 9us or until the SPI fault register is read, whichever comes first, provided the underlying fault condition is resolved. If Field Power Loss or CRC bit is set, other bits in the Fault register (02h) do not care.

7.3.6 Digital Low Pass Filter

The ISO1228 supports in-built digital low pass filters on the INx and WBx data paths. The filters can be programmed through SPI registers (where each channel filter can be individually programmed) or through the pins F0 and F1. F0 and F1 pins support three input states, high, low, and float, resulting in 9 values of digital filtering. Refer to the [Switching Characteristics](#) section for values of the digital filters. The filter values in the SPI registers take precedence. If any SPI filter Enable has a non-zero value, then the states of F0 and F1 pins are ignored.

ISO1228 also supports a digital filter on the Wire Break detection fault. This is a fixed, non-programmable, 30ms filter.

7.3.7 SPI Register Map

Address	NAME	R/W	DESCRIPTION
00h	Input Data	R	Data Information: <7> = IN8 <6> = IN7 . . <0> = IN1
01h	Wire Break	R	Wire Break Information: <7> = WB8 <6> = WB7 <5> = WB6 . . <0> = WB1
02h	Fault	R	Provides the details of the faults in the design: <7> = WB (Any channel shows WB) <6> = OT (Over-temperature threshold is crossed) <5> = Reserved <4> = CRC (Inter-die CRC is in error) <3> = Reserved <2> = Field Side Power Loss <1> = Reserved <0> = UVLO (MCU Side)
03h	Filter Ch 1 and Ch 2	R/W	<7> = Filt Enable, Ch 1 <6:4> = Filter Settings, Ch 1 <3> = Filt Enable, Ch 2 <2:0> = Filter Settings, Ch 2
04h	Filter Ch 3 and Ch 4	R/W	<7> = Filt Enable, Ch 3 <6:4> = Filter Settings, Ch 3 <3> = Filt Enable, Ch 4 <2:0> = Filter Settings, Ch 4
05h	Filter Ch 5 and Ch 6	R/W	<7> = Filt Enable, Ch 5 <6:4> = Filter Settings, Ch 5 <3> = Filt Enable, Ch 6 <2:0> = Filter Settings, Ch 6
06h	Filter Ch 7 and Ch 8	R/W	<7> = Filt Enable, Ch 7 <6:4> = Filter Settings, Ch 7 <3> = Filt Enable, Ch 8 <2:0> = Filter Settings, Ch 8

The Filter settings are described in the [Section 5.10](#).

7.3.8 SPI Interface Timing - Non-Daisy Chain

Figure 7-3 shows the timing diagram for the SPI interface in non-daisy chain mode. ISO1228 has SPI Mode 0 with Clock Polarity = Inactive Low, Clock Phase = Rising/Leading Edge. The bit W/Rn (1/0) determines Write or Read operation. Ab is a 7-bit register for read or write. Wb is the 8-bit write data for Write operation and is ignored for Read operation. Rb is the 8-bit read data from the register addressed by Ab during Read operation, and should be ignored for Write operation. O8-O1 is the state of the 8-digital inputs, IN8-IN1 and is always output on SDO in the Address phase.

If SDI is continuously held at Low (0), the device will treat this as a Read operation from Address 0. Address 0 holds the state on IN8-IN1 (see [SPI Register Map](#)), so in this special case of Read operation the SDO output will be IN8-IN1 in both Address and Read Phases. For applications that are only interested in the state of the digital inputs, and do not want to access other registers for Read/Write, this option may result in a simpler implementation.

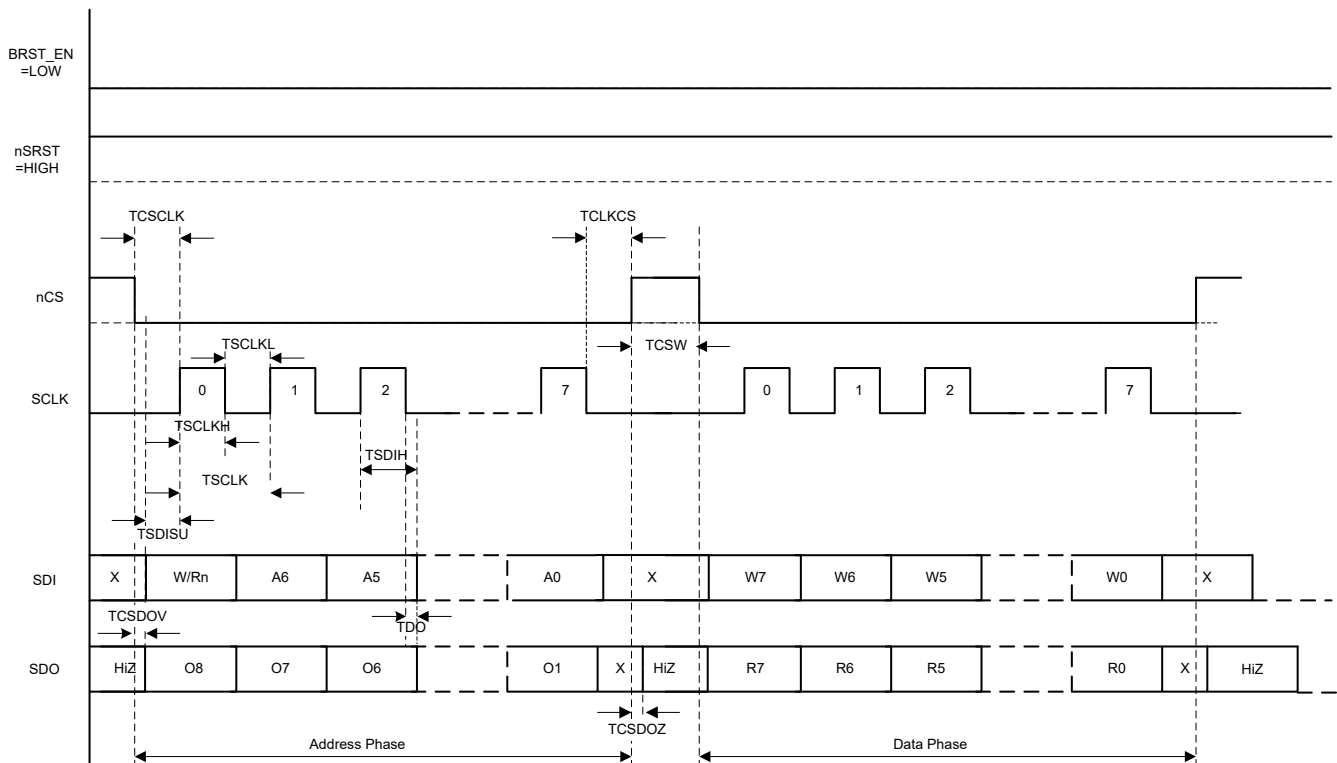

Figure 7-3. SPI Timing Non-Daisy Chain

7.3.9 SPI Interface Timing - Daisy Chain

Figure 7-4 shows an example of two ISO1228 devices in a daisy chain. Up to 8 devices can be daisy chained with ISO1228. Figure 7-5 shows the timing diagram for the SPI interface in daisy chain mode for this two device configuration. The bit W/Rn[x] (1/0) determines Write or Read operation. Ab[x] is a 7-bit register for read or write. Wb[x] is the 8-bit write data for Write operation and is ignored for Read operation. Rb[x] is the 8-bit read data from the register addressed by Ab[x] during Read operation, and should be ignored for Write operation. O8[x]-O1[x] is the state of the 8-digital inputs, IN8-IN1 and is always output on SDO in the address phase.

The Addresses and Data of the the device whose SDO connects to the controller (Device 2 in this example) are shifted in and out first, and those of the device whose SDI is connected to the controller (Device 1 in this example) are shifted in and out last.

If SDI is continuously held at Low (0), the devices in the daisy chain will treat this as a Read operation from Address 0. Address 0 holds the state on IN8-IN1 (see SPI Register Map), so in this special case of read operation the SDO output will be IN8-IN1 in both Address and Read Phases. For applications that are only interested in the state of the digital inputs, and do not want to access other registers for Read/Write, this option may result in a simpler implementation.

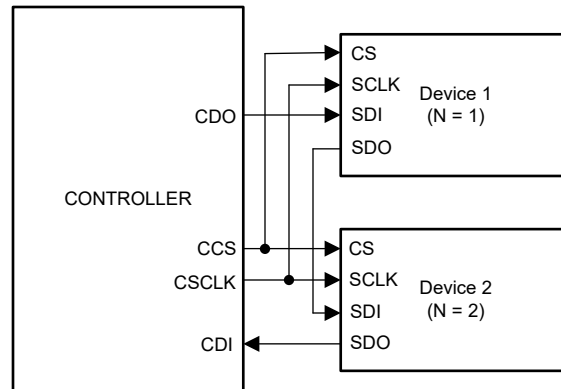

Figure 7-4. SPI Daisy Chain Block Diagram

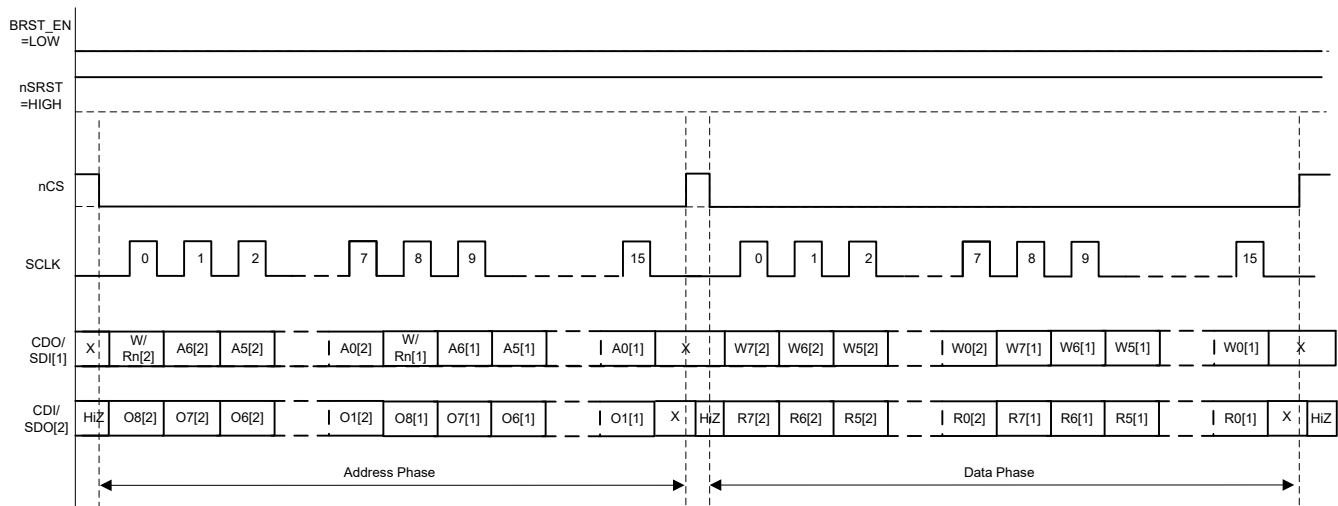

Figure 7-5. SPI Timing Daisy Chain

7.3.10 SPI Interface Timing - Burst Mode

ISO1228 device supports Burst mode SPI operation if the pin BRST=HIGH. In this mode, the outputs of the three SPI read-only registers Reg0, Reg1 and Reg2 are shifted out continuously in a circular manner on every CS toggle. The timing for this mode is shown in Figure 7-6. This mode is suitable for applications that do not want to provide address information through SDI, but want to read out information from Reg0, Reg1 and Reg2. When BRST pin is toggled, the device needs a RESET to update the mode.

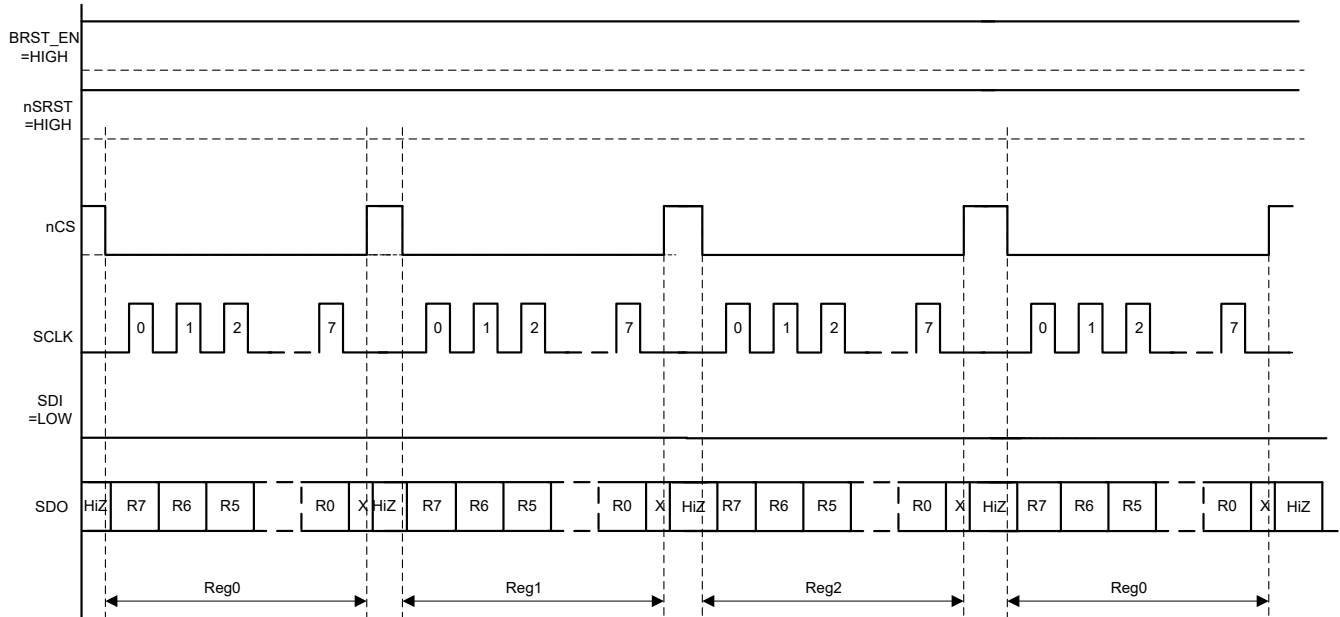

Figure 7-6. SPI Burst Mode Timing Block Diagram

Burst mode operation is also supported in Daisy Chain configuration. On the first CS toggle, the Reg0 information from all devices in the Daisy Chain is read out. On the next CS toggle, Reg1 information from all the devices is read out. On the next CS toggle, Reg2 information, and then back to Reg0 information. The OUT8/SYNC pin is asserted HIGH when Reg0 information is being transmitted for synchronization with the MCU. The timing for Burst mode in Daisy Chain is shown in Figure 7-7. Note that for simplicity the read out of only Reg0 and Reg1 is shown, and with only two devices in the Daisy Chain.

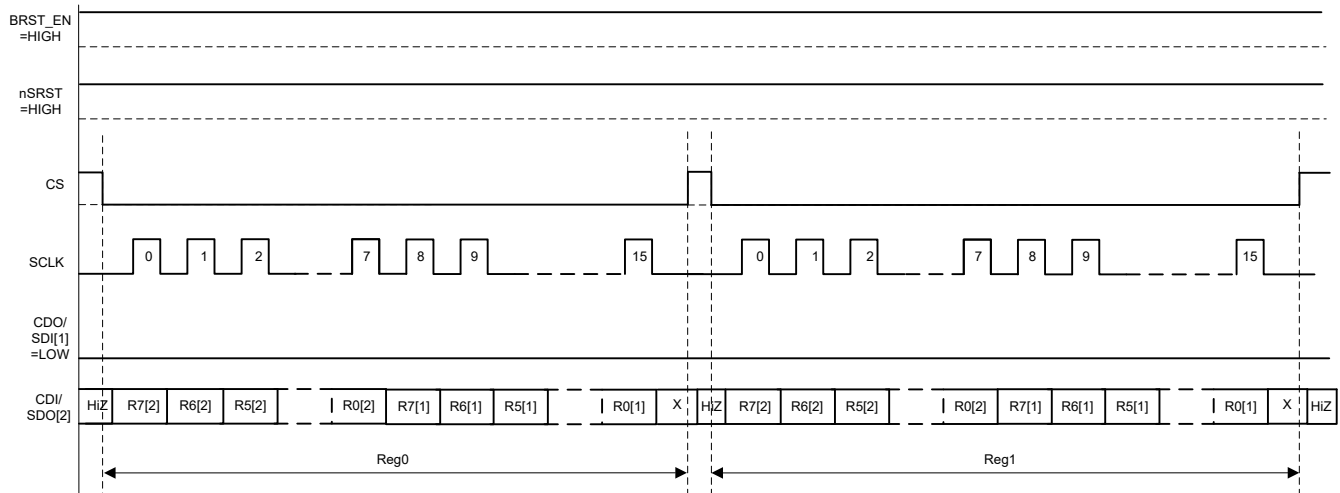

Figure 7-7. SPI Burst Mode Timing Diagram in Daisy Chain

7.4 Device Functional Modes

Table 7-1 lists the functional modes for the ISO1228 device.

Table 7-1. Function Table

AVCC SUPPLY	VCC1 SUPPLY	INPUT (IN _x)	OUTPUT ENABLE (OUT_EN)	OUTPUT (OUT _x)	COMMENTS
PU	PU	H	H	H	Channel output assumes the logic state of channel input.
		L	H	L	
		Open	H	L	When IN _x is open, the output of the corresponding channel goes to Low.
		X	L	Undetermined	All channel outputs are tri-stated.
PD	PU	X	H	L	Channel output is low if AVCC was not previously in powered state
		X	H	H/L	Channel output is last state if AVCC was previously powered state.
		X	L	Undetermined	All channel outputs are tri-stated.
PU	PD	X	X	Undetermined	When V _{CC1} is unpowered, a channel output is undetermined. When V _{CC1} transitions from unpowered to powered up; a channel output assumes the logic state of the input.
PD	PD				

8 Application and Implementation

Note

Information in the following applications sections is not part of the TI component specification, and TI does not warrant its accuracy or completeness. TI's customers are responsible for determining suitability of components for their purposes. Customers should validate and test their design implementation to confirm system functionality.

8.1 Application Information

ISO1228 is an integrated, eight channel isolated digital-input receiver with IEC 61131-2 Type 1, 2, and 3 characteristics. This device is suitable for high-channel density, digital-input modules for programmable logic controllers, and motor control digital input modules. The devices receive digital-input signals up to 36V and provide isolated digital outputs through parallel output or SPI. An external resistor, R_{ILIM} , on the supply path, limits the current drawn into each channel from the field input. This current limit helps minimize power dissipated in the system. The current limit can be set for Type 1, 2, or 3 operations. The voltage transition thresholds are compliant with Type 1, 2, and 3 and can be increased further using an external resistor, R_{THR} on the input path. For more information on selecting the R_{ILIM} and R_{THR} resistor values, see the [Section 7.3](#) section. ISO1228 is capable of high-speed operation and can pass through a minimum pulse width of 667ns.

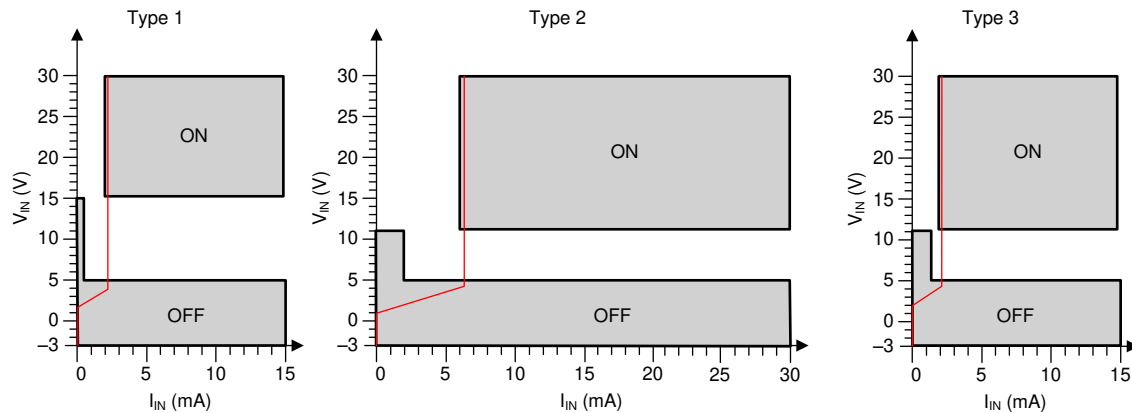

Figure 8-1. Switching Characteristics for IEC61131-2 Type 1, 2, and 3 Proximity Switches

8.2 Typical Application

8.2.1 Sinking Type Digital Inputs

[Figure 8-2](#) shows the implementation of sinking type digital inputs. IN_x pins are connected to the digital inputs through R_{THR} resistors in the range of 180Ω to $2.4k\Omega$. R_{THR} resistors determine voltage transition thresholds at the module input. R_{THR} resistors attenuate the surge current flowing into ISO1228 when surge-proof pulse load resistors are used. The resistor R_{ILIM} controls the current limit of all eight channels. C_{SURGE} value is set to $4.7\mu F$. C_{FIL} value is set to $1nF$. R_{SURGE} and R_{ILIM} surge-proof resistors will be on the AVCC path.

The resistor R_{SURGE} is chosen to filter surges on the V24V module supply. A larger value of R_{SURGE} provides better filtering. The capacitor $C_{SURGE} = 4.7\mu F$ is used to filter surge voltages and any other noise present on the field supply. C_{FIL} provides local decoupling to the IC and should be of $1nF$ value. C_{FIL} should be placed as close to IC as possible. R_{SURGE} , C_{FIL} , and C_{SURGE} are all required for the proper functioning of the current limit function. R_{SURGE} , R_{THR} , R_{ILIM} , and R_{PAR} can be selected from [Voltage Thresholds](#) for IEC 61131-2 Type 1, 2, 3 Isolated Digital Inputs

The capacitor C_{IN} can be optionally used to filter noise on IN_x pins. A value of 100pF to 10nF may be used depending on the module data rate. It is recommended to include a footprint for C_{IN} in the layout, and use it if needed, based on test results.

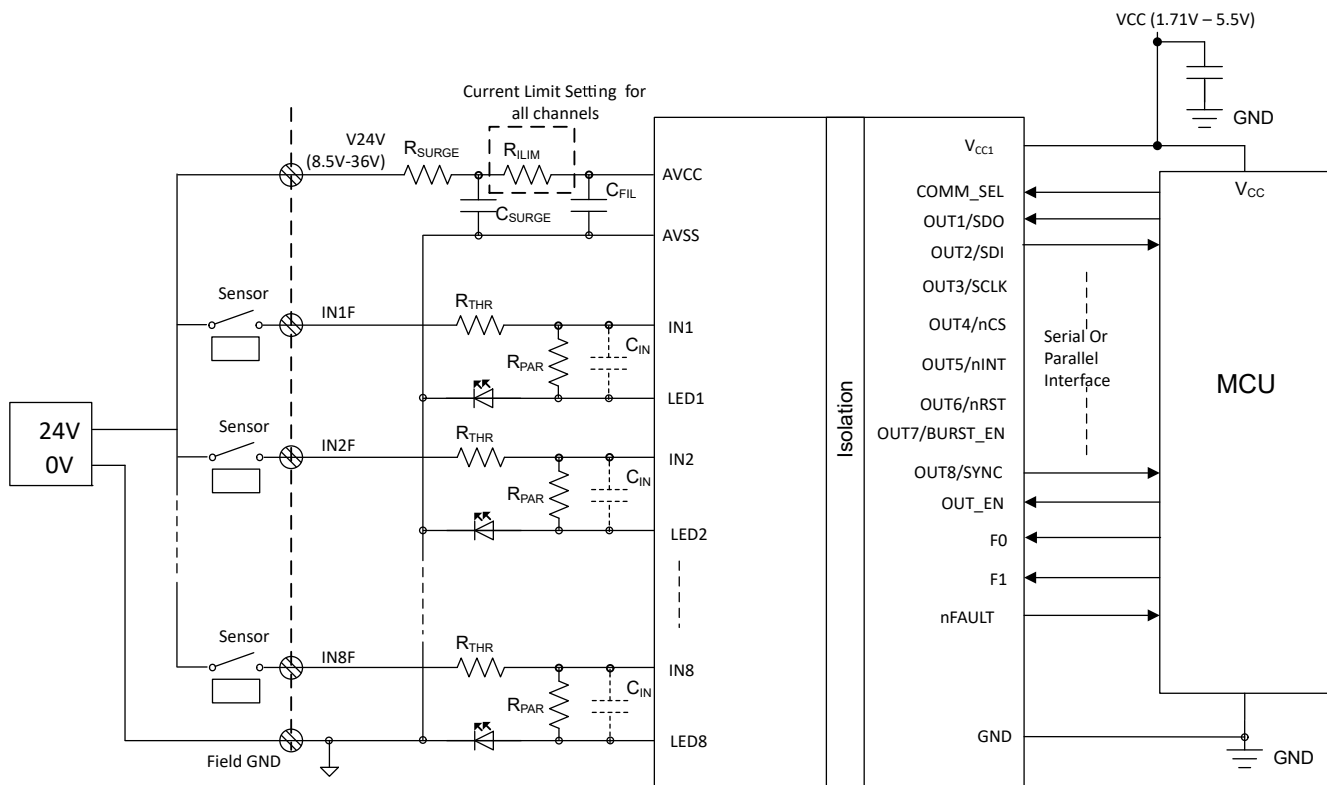

Figure 8-2. Sinking Type Digital Inputs with ISO1228

8.2.2 Sourcing Type Digital Inputs

Figure 8-3 shows the implementation of sourcing type digital inputs. The considerations are similar to sinking type digital inputs, except for a few differences. Firstly, the direction of the LEDs on LED_x pins is reversed, and they are connected to the module field power supply V_{24V} instead of to $AVSS$. Secondly, the R_{LIM} and C_{FIL} components are connected in the $AVSS$ to field Ground path. Both these changes are required to facilitate the

current from the V24V supply to the module inputs through R_{THR} resistors. R_{THR} , R_{ILIM} and R_{PAR} can be selected from [Voltage Thresholds](#) for IEC 61131-2 Type 1, 2, 3 Isolated Digital Inputs.

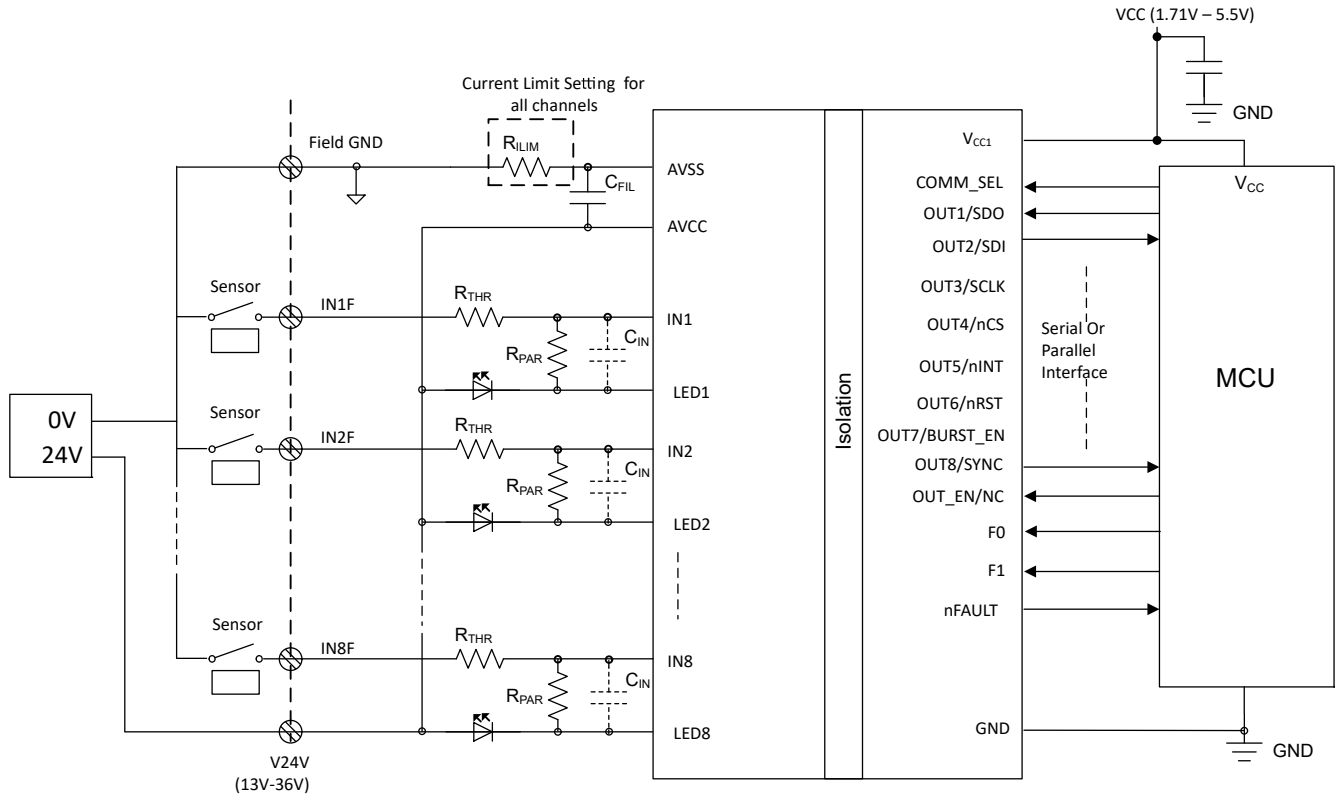

Figure 8-3. Sourcing Type Digital Inputs with ISO1228

8.2.3 Design Requirements

The ISO1228 device requires up to two resistors R_{SURGE} , R_{ILIM} and up to two capacitors C_{SURGE} and C_{ILIM} per device and two resistors, R_{THR} and R_{PAR} per channel. For more information on selecting R_{SURGE} , R_{ILIM} , R_{THR} , and R_{PAR} , see the [Detailed Design Procedure](#) section. A 100nF decoupling capacitor is required on V_{CC1} .

8.2.3.1 Detailed Design Procedure

8.2.3.1.1 Current Limit

The ISO1228 device includes a selectable current limit feature to limit the current drawn from the IN_x pins. Current limiting prevents input current from increasing linearly with input voltage beyond the voltage high transition threshold, reducing both chip and system power dissipation, and board temperature.

The R_{ILIM} and R_{PAR} resistors set the value of the current limit (I_L) according to the equation shown below.

$$I_L \text{ (typical)} = 2.5\text{mA when } R_{ILIM} = 0\text{k}\Omega \text{ \& } R_{PAR} = 13\text{k}\Omega, 3.5\text{mA when } R_{ILIM} = 1\text{k}\Omega \text{ \& } R_{PAR} = 9.76\text{k}\Omega. \quad (1)$$

A 1% tolerance is recommended on R_{PAR} but 5% tolerance can also be used if a higher variation in the current limit value is acceptable. C_{FIL} value is set to 1nF when $R_{ILIM} = 1\text{k}\Omega$. The value of R_{PAR} is the same for all channels and it is required to achieve the correct current limit behavior.

8.2.3.1.2 Voltage Thresholds

The R_{THR} resistor sets the voltage thresholds (V_{IL} and V_{IH}) as well as limits the surge current. A value of 1k Ω is recommended for R_{THR} in Type 3 systems for I_L of 2.5mA (typical) and 910 Ω for I_L of 3.5mA (typical) in sink mode (maximum threshold voltage required is 11V). I_L of 3.5mA is not supported in source mode for Type 2 and Type 3 systems. A value of 1k Ω is recommended for R_{THR} in Type 1 systems (maximum threshold voltage

required is 15V) and a value of 910Ω is recommended for R_{THR} in Type 2 systems. The [Table 8-1](#) and [Source Mode \$R_{THR}\$ Admissible Values \(Ω\)](#) tables list range of R_{THR} values applicable for each mode. Use [Equation 2](#) and [Equation 3](#) to calculate the values for the typical V_{IH} values and minimum V_{IL} values, respectively.

$$V_{IH} \text{ (typical)} = 6.0 \text{ V} + R_{THR} \times I_L \text{ (typical)} \quad (2)$$

$$V_{IL} \text{ (typical)} = 5.0 \text{ V} + R_{THR} \times I_L \text{ (typical)} \quad (3)$$

$$V_{IH} \text{ (max)} = 6.4 \text{ V} + R_{THR} \times I_L \text{ (max)} \quad (4)$$

$$V_{IL} \text{ (min)} = 4.7 \text{ V} + R_{THR} \times I_L \text{ (min)} \quad (5)$$

Refer to the tables for R_{THR} values to achieve IEC 61131-2 Type 1, 2, 3 voltage thresholds. For Type 2 operation, it is recommended to use two channels in parallel, with $R_{ILIM} = 1 \text{ k}\Omega$ and $R_{PAR} = 9.76 \text{ k}\Omega$ operation in sink mode, resulting in a current limit of 7 mA (typical). R_{THR} values can be same as Type 3 operation in this mode.

Table 8-1. Sink Mode R_{THR} Admissible Values (Ω)

SINK MODE							
$R_{ILIM} = 0\Omega, R_{PAR} = 13\text{k}\Omega, R_{SURGE} = 1\text{k}\Omega, (I_L = 2.5\text{mA})$				$R_{ILIM} = 1\text{k}\Omega, R_{PAR} = 9.76\text{k}\Omega, R_{SURGE} = 1\text{k}\Omega, (I_L = 3.5\text{mA})$			
	Min	Typical	Max		Min	Typical	Max
Type 1	180	1000	2400	Type 1	110	910	1740
Type 3	180	1000	1300	Type 3	110	910	930

Table 8-2. Source Mode R_{THR} Admissible Values (Ω)

SOURCE MODE							
$R_{ILIM} = 0\Omega, R_{PAR} = 13\text{k}\Omega (I_L = 2.5\text{mA})$				$R_{ILIM} = 1\text{k}\Omega, R_{PAR} = 9.76\text{k}\Omega, (I_L = 3.5\text{mA})$			
	Min	Typical	Max		Min	Typical	Max
Type 1	180	1000	2400	Type 1	2000	2000	2000
Type 3	180	1000	1300	Type 3	Not Supported		

A tolerance of 5% is acceptable on R_{THR} . Surge resistant resistors is recommended for R_{THR} .

The values in the tables are back calculated from the V_{IH} and V_{IL} formulae mentioned above.

For example;

IEC 61131-2 Type 1 Sink Mode threshold calculations with $R_{ILIM} = 0\text{k}\Omega$,

$V_{OFF_MAX} (5\text{V}) < V_{IL(min)}$, $V_{ON_MIN} (15\text{V}) > V_{IH(max)}$, $I_{L(min)} = 2\text{mA}$ and $I_{L(max)} = 3.3\text{mA}$,

Switching close to OFF state: $V_{OFF_MAX} = V_{IL(min)}$: $5\text{V} = 4.7 \text{ V} + R_{THR} \times I_{L(min)} \Rightarrow R_{THR} = 150\Omega$

With $R_{THR} = 150\Omega$, $V_{ON} = V_{IH(max)} = 6.4\text{V} + 150\Omega \times I_{L(max)} = 6.895\text{V}$ which is less than V_{ON_MIN} (180Ω in the table is a standard resistor to accommodate for 5% tolerance on R_{THR})

Switching close to ON state: $V_{ON_MIN} = V_{IH(max)}$: $15\text{V} = 6.4\text{V} + R_{THR} \times I_{L(max)} \Rightarrow R_{THR} = 2.6\text{k}\Omega$

With $R_{THR} = 2.6\text{k}\Omega$, $V_{OFF} = V_{IL} = 6.4 \text{ V} + 2.6\text{k}\Omega \times I_{L(min)} = 9.9\text{V}$ which is greater than V_{OFF_MAX} (2400Ω in the table is a standard resistor to accommodate for 5% tolerance on R_{THR})

Similarly, other values in the table are derived.

8.2.3.1.3 Wire-Break Detection

Each channel has a wire-break detection circuit which includes a secondary comparator to detect the integrity of field sensor wiring. The sensor or a switch has a wire break resistor across it which passes a small current above 240μA to the INx. If the input current is below the I_{WB} , the WBx in the SPI register is set and it will

be flagged on the nFAULT pin. Wire-break detection works only in Sink Mode. The wire-break resistor R_{IWB} is calculated as per the equation

$$R_{IWB} = (V_{INX} - 2V) / I_{WB} - R_{THR} \quad (6)$$

where V_{INX} is the excitation voltage for the sensor or switch connected.

9 Power Supply Recommendations

To help ensure reliable operation at data rates and supply voltages, a 0.1 μ F bypass capacitor is recommended on the MCU side supply pin (V_{CC1}). The capacitor should be placed as close to the supply pins as possible.

10 Layout

10.1 Layout Guidelines

The board layout for ISO1228 can be completed in two layers. On the field side, place R_{THR} , C_{IN} , R_{PAR} , R_{LIM} , C_{FIL} , R_{SURGE} , and C_{SURGE} on the top layer. Use the bottom layer as the field ground (FGND) plane. TI recommends using R_{PAR} and C_{IN} in 0603 footprints for a compact layout, although larger sizes (0805) can also be used. The C_{IN} capacitor is a 50V capacitor and is available in the 0603 footprint. Keep C_{IN} as close to the ISO1228 device as possible. TI recommends using R_{THR} , R_{SURGE} , R_{LIM} in MELF 0204 footprint surge-proof resistors and 0805 footprint 50V capacitors for C_{SURGE} and C_{FIL} . The placement of the R_{THR} resistor is flexible, although the resistor pin connected to external high voltage should not be placed within 4mm of the ISO1228 device pins or the C_{IN} and R_{PAR} pins to avoid flashover during EMC tests. The placement of LEDs is flexible to display the channel status on the field side.

Only a decoupling capacitor is required on side 1. Place this capacitor on the top-layer, with the bottom layer for GND1.

[Layout Example](#) shows the example layout.

10.2 Layout Example

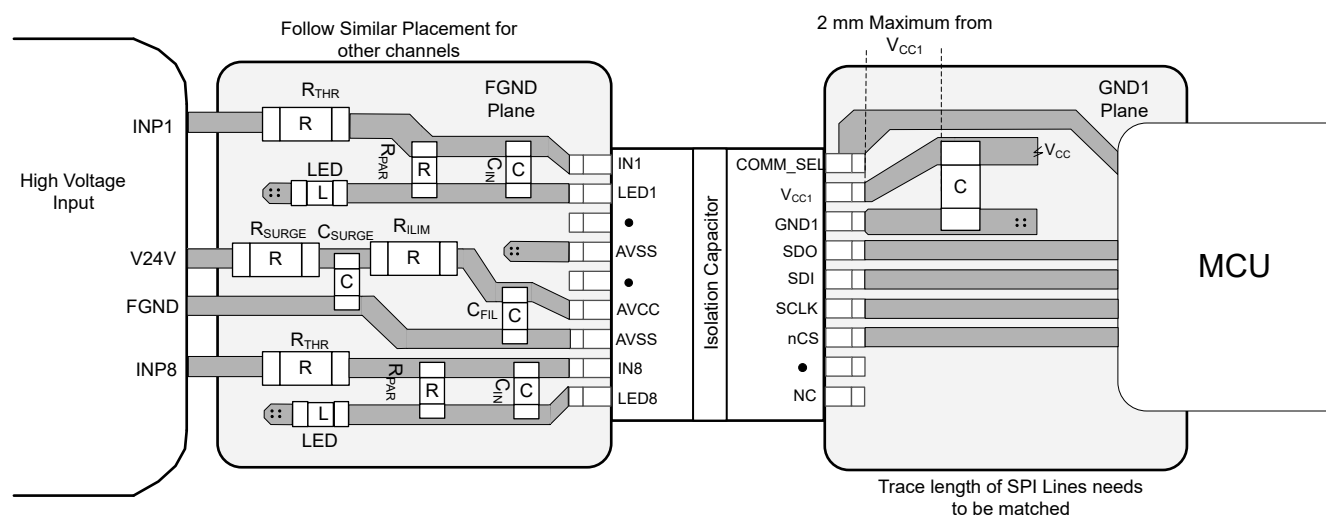

Figure 10-1. Layout Example With ISO1228

11 Device and Documentation Support

11.1 Documentation Support

11.1.1 Related Documentation

For related documentation see the following:

- Texas Instruments, [Digital Isolator Design Guide](#)
- Texas Instruments, [Isolation Glossary](#)

11.2 Receiving Notification of Documentation Updates

To receive notification of documentation updates, navigate to the device product folder on ti.com. In the upper right corner, click on *Alert me* to register and receive a weekly digest of any product information that has changed. For change details, review the revision history included in any revised document.

11.3 Support Resources

TI E2E™ [support forums](#) are an engineer's go-to source for fast, verified answers and design help — straight from the experts. Search existing answers or ask your own question to get the quick design help you need.

Linked content is provided "AS IS" by the respective contributors. They do not constitute TI specifications and do not necessarily reflect TI's views; see TI's [Terms of Use](#).

11.4 Trademarks

TI E2E™ is a trademark of Texas Instruments.
All trademarks are the property of their respective owners.

11.5 Electrostatic Discharge Caution



This integrated circuit can be damaged by ESD. Texas Instruments recommends that all integrated circuits be handled with appropriate precautions. Failure to observe proper handling and installation procedures can cause damage.

ESD damage can range from subtle performance degradation to complete device failure. Precision integrated circuits may be more susceptible to damage because very small parametric changes could cause the device not to meet its published specifications.

11.6 Glossary

[TI Glossary](#) This glossary lists and explains terms, acronyms, and definitions.

12 Revision History

NOTE: Page numbers for previous revisions may differ from page numbers in the current version.

Changes from Revision * (June 2023) to Revision A (February 2024)	Page
• Updated device status from advanced information to production data.....	1
• Added test circuits and the <i>Parameter Measurement Information</i> section.....	17

13 Mechanical, Packaging, and Orderable Information

The following pages include mechanical packaging and orderable information. This information is the most current data available for the designated devices. This data is subject to change without notice and revision of this document. For browser-based versions of this data sheet, refer to the left-hand navigation.

PACKAGE OUTLINE

DFB0038A

SSOP - 1.75 mm max height

SMALL OUTLINE PACKAGE

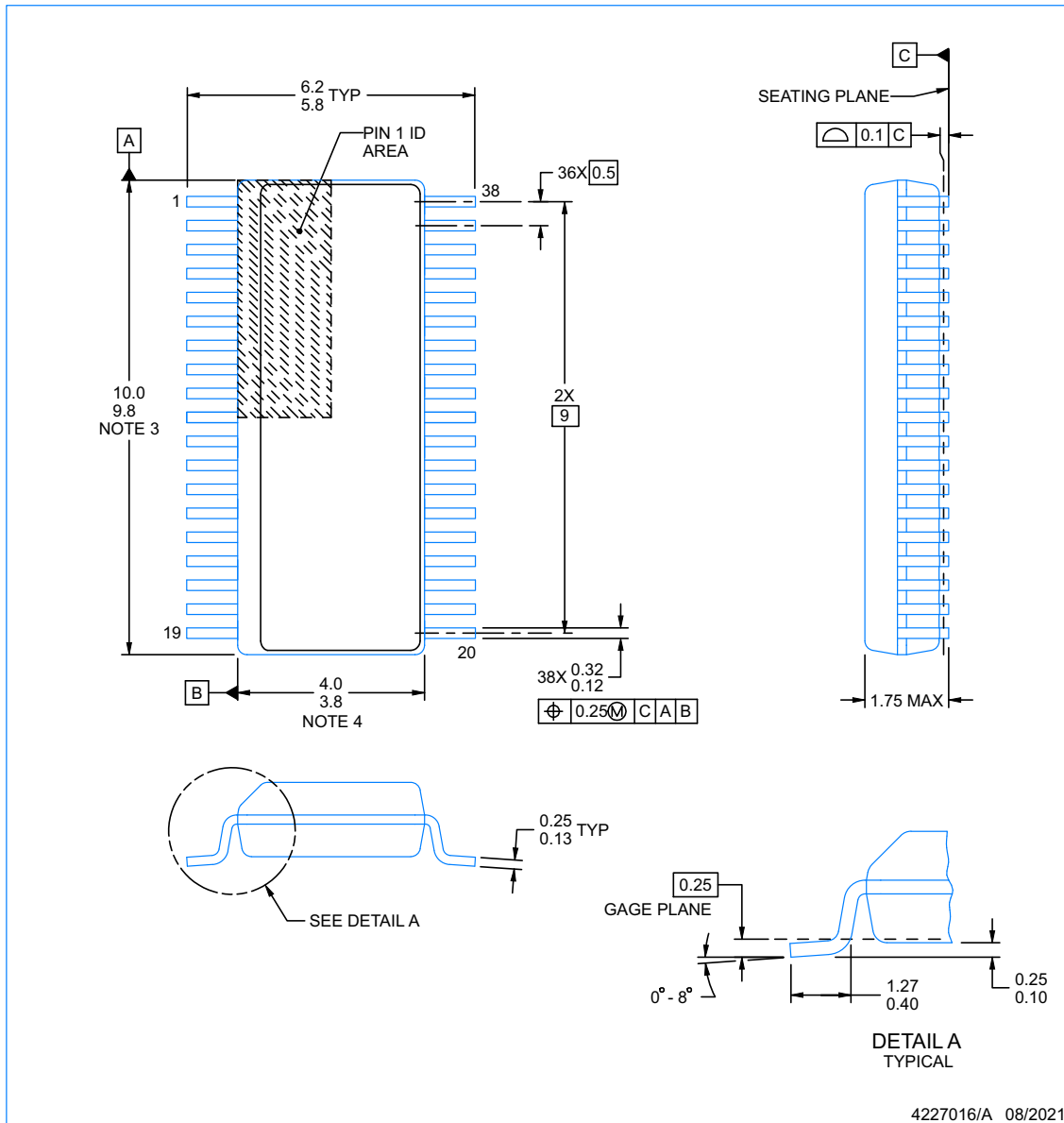

NOTES:

1. All linear dimensions are in millimeters. Dimensions in parenthesis are for reference only. Dimensioning and tolerancing per ASME Y14.5M.
2. This drawing is subject to change without notice.
3. This dimension does not include mold flash, protrusions, or gate burrs. Mold flash, protrusions, or gate burrs shall not exceed 0.15 mm per side.
4. This dimension does not include interlead flash. Interlead flash shall not exceed 0.43 mm per side.
5. Reference JEDEC registration MS-012.

EXAMPLE BOARD LAYOUT

DFB0038A

SSOP - 1.75 mm max height

SMALL OUTLINE PACKAGE

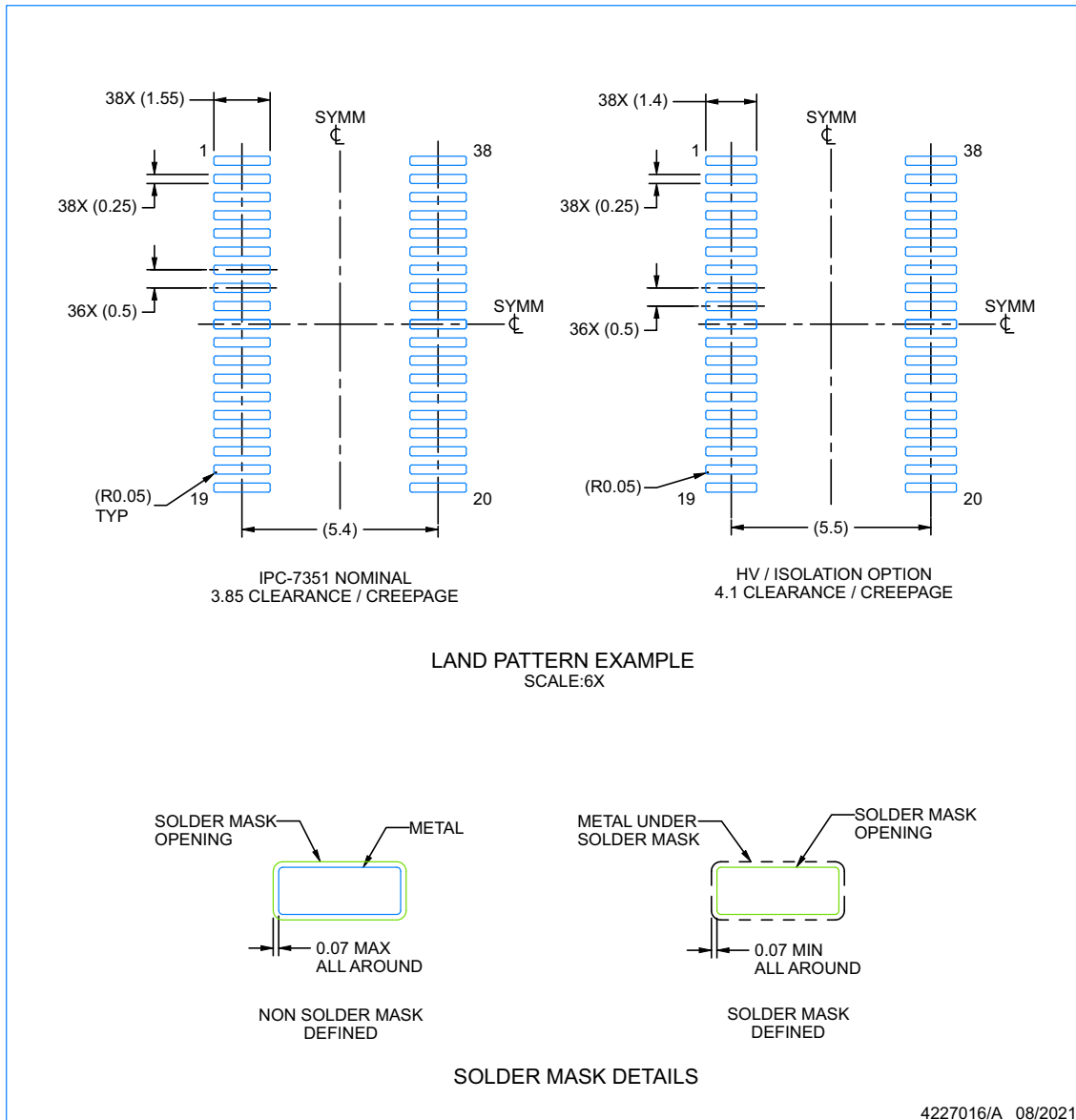

NOTES: (continued)

- 6. Publication IPC-7351 may have alternate designs.
- 7. Solder mask tolerances between and around signal pads can vary based on board fabrication site.

EXAMPLE STENCIL DESIGN

DFB0038A

SSOP - 1.75 mm max height

SMALL OUTLINE PACKAGE

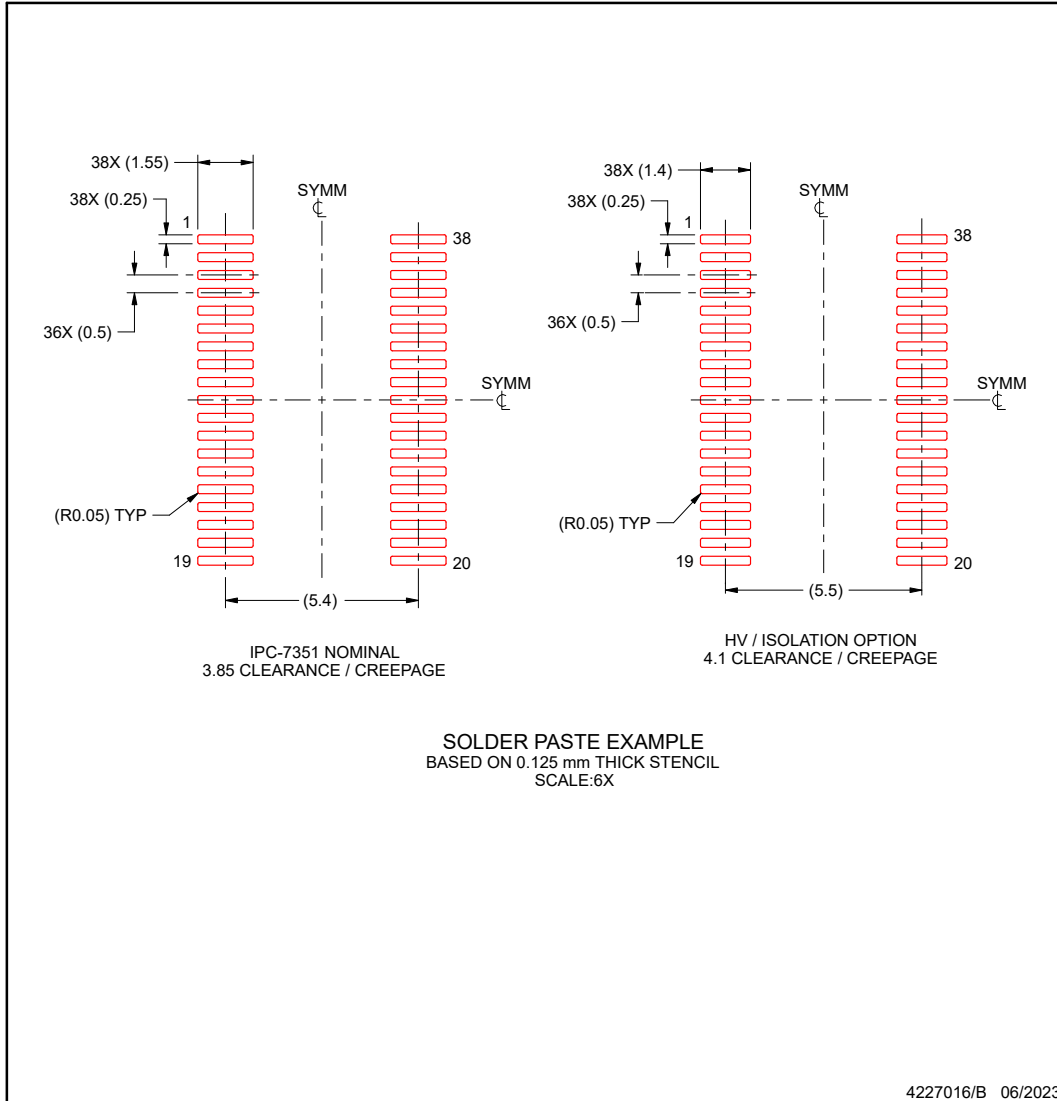

NOTES: (continued)

- 8. Laser cutting apertures with trapezoidal walls and rounded corners may offer better paste release. IPC-7525 may have alternate design recommendations.
- 9. Board assembly site may have different recommendations for stencil design.

13.1 Tape and Reel Information

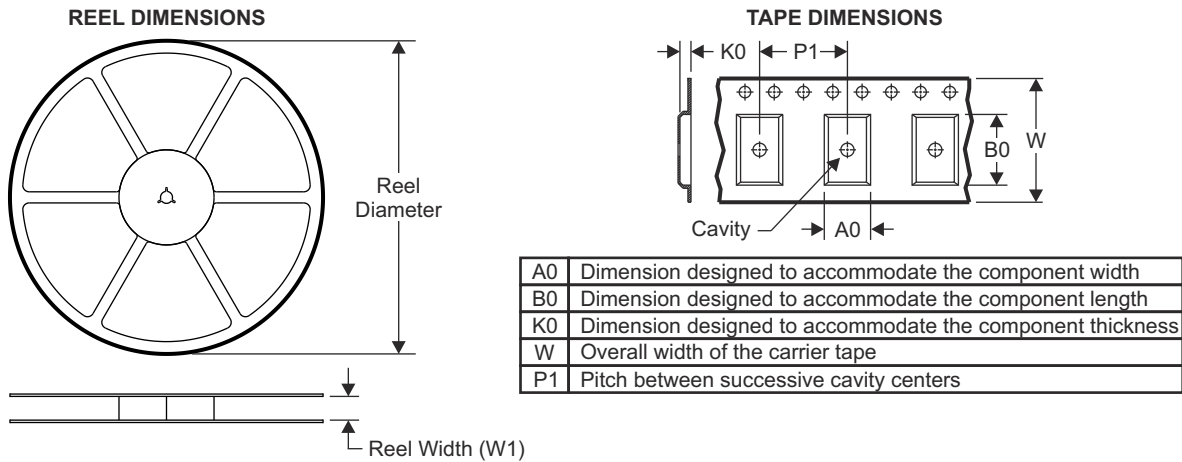

QUADRANT ASSIGNMENTS FOR PIN 1 ORIENTATION IN TAPE

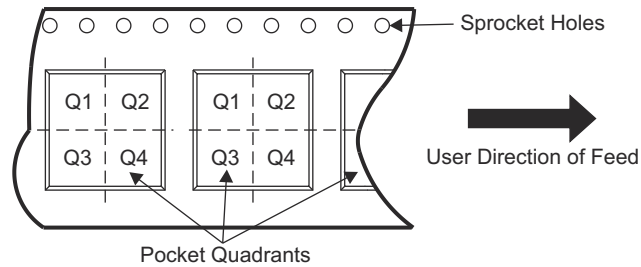

Device	Package Type	Package Drawing	Pins	SPQ	Reel Diameter (mm)	Reel Width W1 (mm)	A0 (mm)	B0 (mm)	K0 (mm)	P1 (mm)	W (mm)	Pin1 Quadrant
ISO1228DFBR	SSOP	DFB	38	2500	330	16.4	6.5	10.3	2.1	8	16	Q1

TAPE AND REEL BOX DIMENSIONS

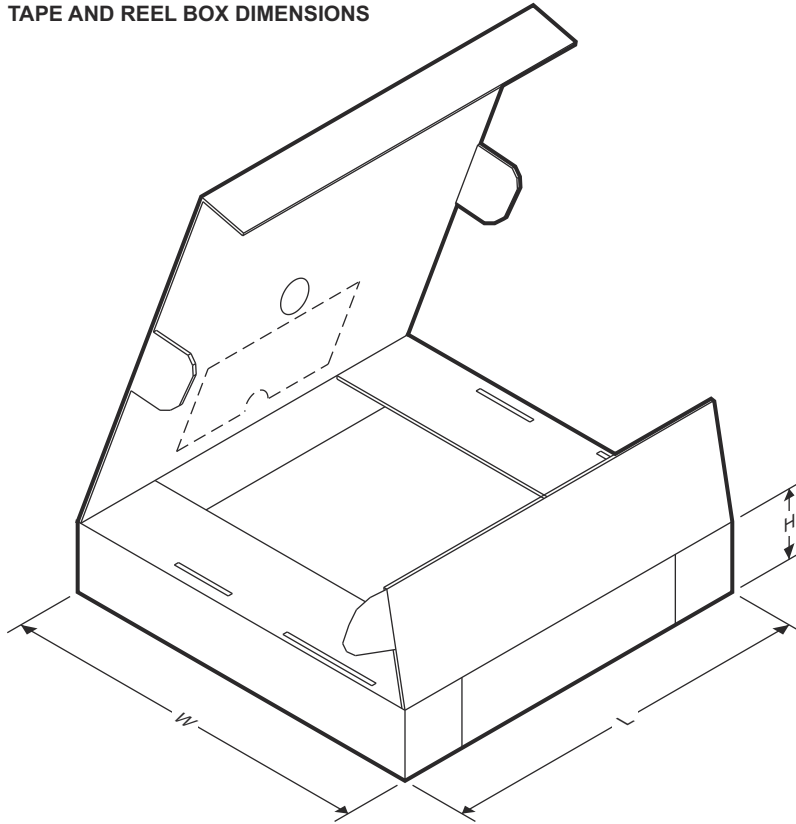

Device	Package Type	Package Drawing	Pins	SPQ	Length (mm)	Width (mm)	Height (mm)
ISO1228DFBR	SSOP	DFB	38	2500	470	380	43

PACKAGING INFORMATION

Orderable Device	Status (1)	Package Type	Package Drawing	Pins	Package Qty	Eco Plan (2)	Lead finish/ Ball material (6)	MSL Peak Temp (3)	Op Temp (°C)	Device Marking (4/5)	Samples
ISO1228DFBR	ACTIVE	SSOP	DFB	38	2500	RoHS & Green	NIPDAU	Level-2-260C-1 YEAR	-40 to 125	ISO1228	Samples
XISO1228DFBR	ACTIVE	SSOP	DFB	38	2500	TBD	Call TI	Call TI	-40 to 125		Samples

(1) The marketing status values are defined as follows:

ACTIVE: Product device recommended for new designs.

LIFEBUY: TI has announced that the device will be discontinued, and a lifetime-buy period is in effect.

NRND: Not recommended for new designs. Device is in production to support existing customers, but TI does not recommend using this part in a new design.

PREVIEW: Device has been announced but is not in production. Samples may or may not be available.

OBSOLETE: TI has discontinued the production of the device.

(2) **RoHS:** TI defines "RoHS" to mean semiconductor products that are compliant with the current EU RoHS requirements for all 10 RoHS substances, including the requirement that RoHS substance do not exceed 0.1% by weight in homogeneous materials. Where designed to be soldered at high temperatures, "RoHS" products are suitable for use in specified lead-free processes. TI may reference these types of products as "Pb-Free".

RoHS Exempt: TI defines "RoHS Exempt" to mean products that contain lead but are compliant with EU RoHS pursuant to a specific EU RoHS exemption.

Green: TI defines "Green" to mean the content of Chlorine (Cl) and Bromine (Br) based flame retardants meet JS709B low halogen requirements of <=1000ppm threshold. Antimony trioxide based flame retardants must also meet the <=1000ppm threshold requirement.

(3) MSL, Peak Temp. - The Moisture Sensitivity Level rating according to the JEDEC industry standard classifications, and peak solder temperature.

(4) There may be additional marking, which relates to the logo, the lot trace code information, or the environmental category on the device.

(5) Multiple Device Markings will be inside parentheses. Only one Device Marking contained in parentheses and separated by a "~" will appear on a device. If a line is indented then it is a continuation of the previous line and the two combined represent the entire Device Marking for that device.

(6) Lead finish/Ball material - Orderable Devices may have multiple material finish options. Finish options are separated by a vertical ruled line. Lead finish/Ball material values may wrap to two lines if the finish value exceeds the maximum column width.

Important Information and Disclaimer:The information provided on this page represents TI's knowledge and belief as of the date that it is provided. TI bases its knowledge and belief on information provided by third parties, and makes no representation or warranty as to the accuracy of such information. Efforts are underway to better integrate information from third parties. TI has taken and continues to take reasonable steps to provide representative and accurate information but may not have conducted destructive testing or chemical analysis on incoming materials and chemicals. TI and TI suppliers consider certain information to be proprietary, and thus CAS numbers and other limited information may not be available for release.

In no event shall TI's liability arising out of such information exceed the total purchase price of the TI part(s) at issue in this document sold by TI to Customer on an annual basis.

TAPE AND REEL INFORMATION

QUADRANT ASSIGNMENTS FOR PIN 1 ORIENTATION IN TAPE

*All dimensions are nominal

Device	Package Type	Package Drawing	Pins	SPQ	Reel Diameter (mm)	Reel Width W1 (mm)	A0 (mm)	B0 (mm)	K0 (mm)	P1 (mm)	W (mm)	Pin1 Quadrant
ISO1228DFBR	SSOP	DFB	38	2500	330.0	16.4	6.5	10.3	2.1	8.0	16.0	Q1

TAPE AND REEL BOX DIMENSIONS

*All dimensions are nominal

Device	Package Type	Package Drawing	Pins	SPQ	Length (mm)	Width (mm)	Height (mm)
ISO1228DFBR	SSOP	DFB	38	2500	350.0	350.0	43.0

IMPORTANT NOTICE AND DISCLAIMER

TI PROVIDES TECHNICAL AND RELIABILITY DATA (INCLUDING DATA SHEETS), DESIGN RESOURCES (INCLUDING REFERENCE DESIGNS), APPLICATION OR OTHER DESIGN ADVICE, WEB TOOLS, SAFETY INFORMATION, AND OTHER RESOURCES "AS IS" AND WITH ALL FAULTS, AND DISCLAIMS ALL WARRANTIES, EXPRESS AND IMPLIED, INCLUDING WITHOUT LIMITATION ANY IMPLIED WARRANTIES OF MERCHANTABILITY, FITNESS FOR A PARTICULAR PURPOSE OR NON-INFRINGEMENT OF THIRD PARTY INTELLECTUAL PROPERTY RIGHTS.

These resources are intended for skilled developers designing with TI products. You are solely responsible for (1) selecting the appropriate TI products for your application, (2) designing, validating and testing your application, and (3) ensuring your application meets applicable standards, and any other safety, security, regulatory or other requirements.

These resources are subject to change without notice. TI grants you permission to use these resources only for development of an application that uses the TI products described in the resource. Other reproduction and display of these resources is prohibited. No license is granted to any other TI intellectual property right or to any third party intellectual property right. TI disclaims responsibility for, and you will fully indemnify TI and its representatives against, any claims, damages, costs, losses, and liabilities arising out of your use of these resources.

TI's products are provided subject to [TI's Terms of Sale](#) or other applicable terms available either on [ti.com](https://www.ti.com) or provided in conjunction with such TI products. TI's provision of these resources does not expand or otherwise alter TI's applicable warranties or warranty disclaimers for TI products.

TI objects to and rejects any additional or different terms you may have proposed.

Mailing Address: Texas Instruments, Post Office Box 655303, Dallas, Texas 75265
Copyright © 2024, Texas Instruments Incorporated