

ISO776x-Q1 High-speed, robust EMC, reinforced six-channel digital isolators

1 Features

- Qualified for automotive applications
- AEC-Q100 qualified with the following results:
 - Device temperature grade 1: -40°C to $+125^{\circ}\text{C}$ ambient temperature range
 - Device HBM ESD classification level 3A
 - Device CDM ESD classification level C6
- **Functional Safety-Capable**
 - Documentation available to aid functional safety system design: [ISO7760-Q1](#), [ISO7761-Q1](#), [ISO7762-Q1](#), [ISO7763-Q1](#)
- 100 Mbps data rate
- Robust isolation barrier:
 - >30-Year projected lifetime
 - Up to 5000 V_{RMS} isolation rating
 - Up to 12.8 kV surge capability
 - ± 100 kV/ μs Typical CMTI
- Wide supply range: 2.25 V to 5.5 V
- 2.25-V to 5.5-V Level translation
- Default output *high* (ISO776x) and *low* (ISO776xF) Options
- Low power consumption, typical 1.4 mA per channel at 1 Mbps
- Low propagation delay: 11 ns typical at 5 V
- Robust Electromagnetic Compatibility (EMC):
 - System-level ESD, EFT, and surge immunity
 - ± 8 kV IEC 61000-4-2 Contact discharge protection across isolation barrier
 - Low emissions
- Wide-SOIC (DW-16) and SSOP (DBQ-16) package options
- Safety-related certifications:
 - Reinforced insulation per DIN EN IEC 60747-17 (VDE 0884-17)
 - UL 1577 component recognition program
 - CSA certification per IEC 62368-1 and IEC 60601-1
 - CQC certification per GB4943.1
 - TUV certification according to EN 62368-1 and EN 61010-1

2 Applications

- Hybrid, electric and power train system (EV/HEV)
 - Battery management system (BMS)
 - On-board charger
 - Traction inverter

- DC/DC converter
- Starter/generator

3 Description

The ISO776x-Q1 devices are high-performance, six-channel digital isolators with 5000- V_{RMS} (DW package) and 3000- V_{RMS} (DBQ package) isolation ratings per UL 1577. This family of devices is also certified according to VDE, CSA, TUV and CQC.

The ISO776x-Q1 family of devices provides high-electromagnetic immunity and low emissions at low-power consumption, while isolating CMOS or LVCMOS digital I/Os. Each isolation channel has a logic-input and logic-output buffer separated by a double capacitive silicon dioxide (SiO_2) insulation barrier. The ISO776x-Q1 family of devices is available in all possible pin configurations such that all six channels are in the same direction, or one, two, or three channels are in reverse direction while the remaining channels are in forward direction. If the input power or signal is lost, the default output is *high* for devices without suffix F and *low* for devices with suffix F. See the [Device Functional Modes](#) section for further details.

Device Information

PART NUMBER ⁽¹⁾	PACKAGE	BODY SIZE (NOM)
ISO7760-Q1 ISO7761-Q1 ISO7762-Q1 ISO7763-Q1	SOIC (16)	10.30 mm × 7.50 mm
	SSOP (16)	4.90 mm × 3.90 mm

(1) For all available packages, see the orderable addendum at the end of the datasheet.

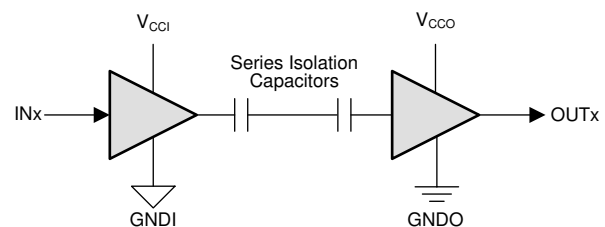

Copyright © 2016, Texas Instruments Incorporated

V_{CCI} =Input V_{CC} , V_{CCO} =Output V_{CC}
 GNDI =Input ground, GNDO =Output ground

Simplified Schematic



Table of Contents

1 Features	1	6.19 Typical Characteristics.....	23
2 Applications	1	7 Detailed Description	27
3 Description	1	7.1 Overview.....	27
4 Description (Continued)	2	7.2 Functional Block Diagram.....	27
5 Pin Configuration and Functions	3	7.3 Feature Description.....	28
6 Specifications	6	7.4 Device Functional Modes.....	29
6.1 Absolute Maximum Ratings.....	6	8 Application and Implementation	30
6.2 ESD Ratings.....	6	8.1 Application Information.....	30
6.3 Recommended Operating Conditions.....	7	8.2 Typical Application.....	30
6.4 Thermal Information.....	8	9 Power Supply Recommendations	33
6.5 Power Ratings.....	8	10 Layout	34
6.6 Insulation Specifications.....	9	10.1 Layout Guidelines.....	34
6.7 Safety-Related Certifications.....	11	10.2 Layout Example.....	34
6.8 Safety Limiting Values.....	11	11 Device and Documentation Support	35
6.9 Electrical Characteristics—5-V Supply.....	13	11.1 Documentation Support.....	35
6.10 Supply Current Characteristics—5-V Supply.....	13	11.2 Related Links.....	35
6.11 Electrical Characteristics—3.3-V Supply.....	15	11.3 Receiving Notification of Documentation Updates..	35
6.12 Supply Current Characteristics—3.3-V Supply.....	15	11.4 Support Resources.....	35
6.13 Electrical Characteristics—2.5-V Supply.....	17	11.5 Trademarks.....	35
6.14 Supply Current Characteristics—2.5-V Supply.....	17	11.6 Electrostatic Discharge Caution.....	35
6.15 Switching Characteristics—5-V Supply.....	19	11.7 Glossary.....	36
6.16 Switching Characteristics—3.3-V Supply.....	20	12 Revision History	36
6.17 Switching Characteristics—2.5-V Supply.....	21	13 Mechanical, Packaging, and Orderable Information	36
6.18 Insulation Characteristics Curves.....	22		

4 Description (Continued)

Used in conjunction with isolated power supplies, this family of devices helps prevent noise currents on data buses, such as CAN and LIN, or other circuits from entering the local ground and interfering with or damaging sensitive circuitry. Through innovative chip design and layout techniques, electromagnetic compatibility of the ISO776x-Q1 family of devices has been significantly enhanced to ease system-level ESD, EFT, surge, and emissions compliance. The ISO776x-Q1 family of devices is available in 16-pin SOIC and SSOP packages.

5 Pin Configuration and Functions

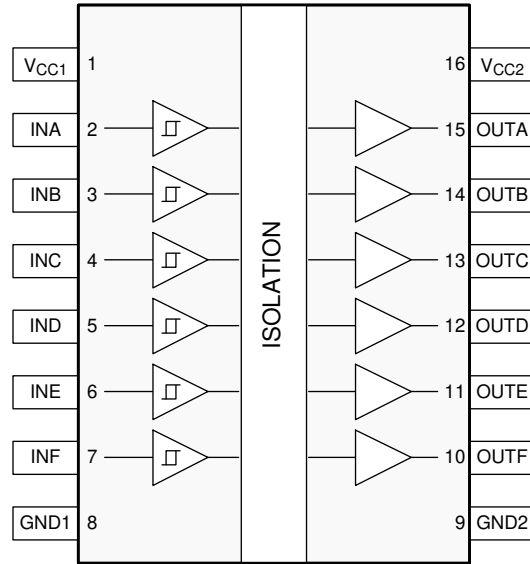

Figure 5-1. ISO7760-Q1 DW and DBQ Packages 16-Pin SOIC and SSOP Top View

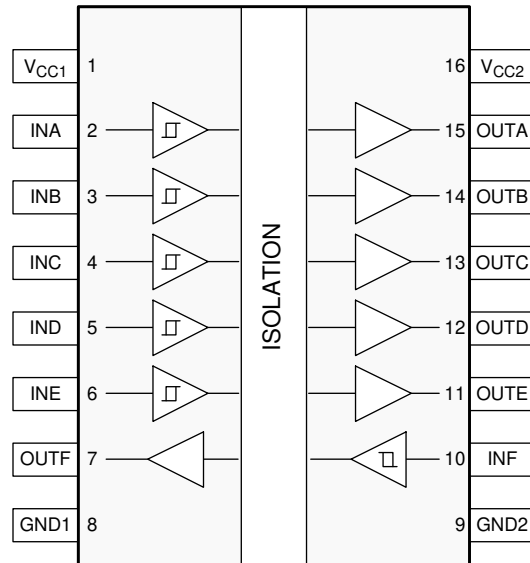

Figure 5-2. ISO7761-Q1 DW and DBQ Packages 16-Pin SOIC and SSOP Top View

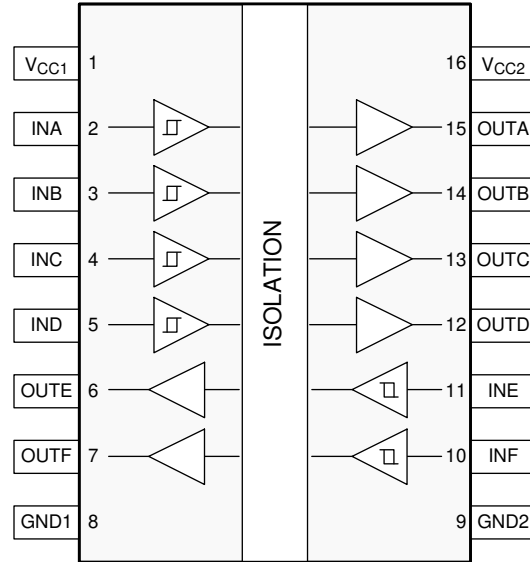

Figure 5-3. ISO7762-Q1 DW and DBQ Packages 16-Pin SOIC and SSOP Top View

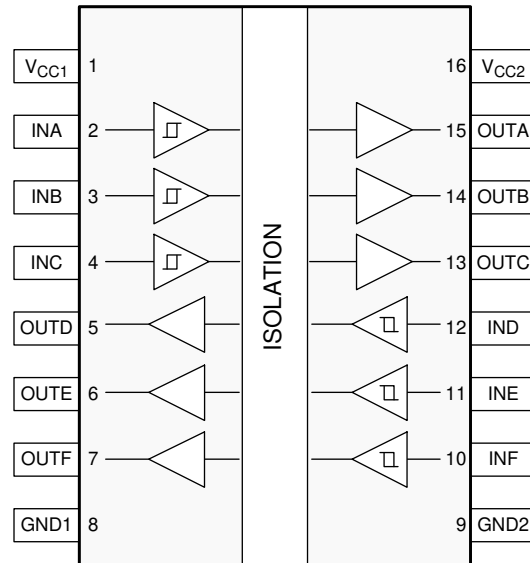

Figure 5-4. ISO7763-Q1 DW and DBQ Packages 16-Pin SOIC and SSOP Top View

Table 5-1. Pin Functions

NAME	PIN				I/O	DESCRIPTION
	NO.					
	ISO7760-Q1	ISO7761-Q1	ISO7762-Q1	ISO7763-Q1		
GND1	8	8	8	8	—	Ground connection for V _{CC1}
GND2	9	9	9	9	—	Ground connection for V _{CC2}
INA	2	2	2	2	I	Input, channel A
INB	3	3	3	3	I	Input, channel B
INC	4	4	4	4	I	Input, channel C
IND	5	5	5	12	I	Input, channel D
INE	6	6	11	11	I	Input, channel E
INF	7	10	10	10	I	Input, channel F
OUTA	15	15	15	15	O	Output, channel A
OUTB	14	14	14	14	O	Output, channel B
OUTC	13	13	13	13	O	Output, channel C
OUTD	12	12	12	5	O	Output, channel D
OUTE	11	11	6	6	O	Output, channel E
OUTF	10	7	7	7	O	Output, channel F
V _{CC1}	1	1	1	1	—	Power supply, side 1
V _{CC2}	16	16	16	16	—	Power supply, side 2

6 Specifications

6.1 Absolute Maximum Ratings

See⁽¹⁾

		MIN	MAX	UNIT
V_{CC1}, V_{CC2}	Supply voltage ⁽²⁾	-0.5	6	V
V	Voltage at INx, OUTx	-0.5	$V_{CCX} + 0.5$ ⁽³⁾	V
I_o	Output current	-15	15	mA
T_J	Junction temperature		150	°C
T_{stg}	Storage temperature	-65	150	°C

- (1) Stresses beyond those listed under Absolute Maximum Ratings may cause permanent damage to the device. These are stress ratings only, which do not imply functional operation of the device at these or any other conditions beyond those indicated under Recommended Operating Conditions. Exposure to absolute-maximum-rated conditions for extended periods may affect device reliability.
- (2) All voltage values except differential I/O bus voltages are with respect to the local ground terminal (GND1 or GND2) and are peak voltage values
- (3) Maximum voltage must not exceed 6 V.

6.2 ESD Ratings

(1)

			VALUE	UNIT
$V_{(ESD)}$	Electrostatic discharge	Human body model (HBM),per AEC Q100-002 ⁽¹⁾	±6000	V
		Charged device model (CDM),per AEC Q100-011	±1500	
		Contact discharge per IEC 61000-4-2; Isolation barrier withstand test ^{(2) (3)}	±8000	V

- (1) AEC Q100-002 indicates that HBM stressing shall be in accordance with the ANSI/ESDA/JEDEC JS-001 specification.
- (2) IEC ESD strike is applied across the barrier with all pins on each side tied together creating a two-terminal device.
- (3) Testing is carried out in air or oil to determine the intrinsic contact discharge capability of the device.

6.3 Recommended Operating Conditions

		MIN	NOM	MAX	UNIT
V_{CC1}, V_{CC2}	Supply Voltage	2.25		5.5	V
$V_{cc (UVLO+)}$	UVLO threshold when supply voltage is rising		2	2.25	V
$V_{cc (UVLO-)}$	UVLO threshold when supply voltage is falling	1.7	1.8		V
$V_{HYS (UVLO)}$	Supply voltage UVLO hysteresis	100	200		mV
I_{OH}	High level output current	$V_{CCO}^{(1)} = 5\text{ V}$		-4	mA
		$V_{CCO} = 3.3\text{ V}$		-2	
		$V_{CCO} = 2.5\text{ V}$		-1	
I_{OL}	Low level output current	$V_{CCO} = 5\text{ V}$		4	mA
		$V_{CCO} = 3.3\text{ V}$		2	
		$V_{CCO} = 2.5\text{ V}$		1	
V_{IH}	High level Input voltage	$0.7 \times V_{CCI}^{(1)}$		V_{CCI}	V
V_{IL}	Low level Input voltage	0		$0.3 \times V_{CCI}$	V
$DR^{(2)}$	Data Rate	0		100	Mbps
T_A	Ambient temperature	-55	25	125	°C

(1) V_{CCI} = Input-side V_{CC} ; V_{CCO} = Output-side V_{CC}

(2) 100 Mbps is the maximum specified data rate, although higher data rates are possible.

6.4 Thermal Information

THERMAL METRIC ⁽¹⁾		ISO776x		UNIT
		DW (SOIC)	DBQ (SSOP)	
		16 PINS	16 PINS	
$R_{\theta JA}$	Junction-to-ambient thermal resistance	60.3	86.5	°C/W
$R_{\theta JC(top)}$	Junction-to-case (top) thermal resistance	24.0	26.9	°C/W
$R_{\theta JB}$	Junction-to-board thermal resistance	29.3	36.6	°C/W
Ψ_{JT}	Junction-to-top characterization parameter	3.3	1.7	°C/W
Ψ_{JB}	Junction-to-board characterization parameter	28.7	36.1	°C/W
$R_{\theta JC(bot)}$	Junction-to-case (bottom) thermal resistance	n/a	n/a	°C/W

(1) For more information about traditional and new thermal metrics, see the [Semiconductor and IC Package Thermal Metrics application report](#).

6.5 Power Ratings

PARAMETER		TEST CONDITIONS	MIN	TYP	MAX	UNIT
ISO7760						
P_D	Maximum power dissipation (both sides)	$V_{CC1} = V_{CC2} = 5.5\text{ V}$, $T_J = 150^\circ\text{C}$, $C_L = 15\text{ pF}$, Input a 50-MHz 50% duty cycle square wave			314	mW
P_{D1}	Maximum power dissipation (side-1)				55	mW
P_{D2}	Maximum power dissipation (side-2)				259	mW
ISO7761						
P_D	Maximum power dissipation (both sides)	$V_{CC1} = V_{CC2} = 5.5\text{ V}$, $T_J = 150^\circ\text{C}$, $C_L = 15\text{ pF}$, Input a 50-MHz 50% duty cycle square wave			314	mW
P_{D1}	Maximum power dissipation (side-1)				88	mW
P_{D2}	Maximum power dissipation (side-2)				226	mW
ISO7762						
P_D	Maximum power dissipation (both sides)	$V_{CC1} = V_{CC2} = 5.5\text{ V}$, $T_J = 150^\circ\text{C}$, $C_L = 15\text{ pF}$, Input a 50-MHz 50% duty cycle square wave			314	mW
P_{D1}	Maximum power dissipation (side-1)				122	mW
P_{D2}	Maximum power dissipation (side-2)				192	mW
ISO7763						
P_D	Maximum power dissipation (both sides)	$V_{CC1} = V_{CC2} = 5.5\text{ V}$, $T_J = 150^\circ\text{C}$, $C_L = 15\text{ pF}$, Input a 50-MHz 50% duty cycle square wave			314	mW
P_{D1}	Maximum power dissipation (side-1)				157	mW
P_{D2}	Maximum power dissipation (side-2)				157	mW

6.6 Insulation Specifications

PARAMETER		TEST CONDITIONS	VALUE		UNIT
			DW-16	DBQ-16	
CLR	External clearance ⁽¹⁾	Shortest terminal-to-terminal distance through air	>8	>3.7	mm
CPG	External creepage ⁽¹⁾	Shortest terminal-to-terminal distance across the package surface	>8	>3.7	mm
DTI	Distance through the insulation	Minimum internal gap (internal clearance)	>17	>17	μm
CTI	Comparative tracking index	DIN EN 60112 (VDE 0303-11); IEC 60112; UL 746A	>600	>600	V
	Material group	According to IEC 60664-1	I	I	
	Overvoltage category per IEC 60664-1	Rated mains voltage ≤ 150 V _{RMS}	I-IV	I-IV	
		Rated mains voltage ≤ 300 V _{RMS}	I-IV	I-III	
		Rated mains voltage ≤ 600 V _{RMS}	I-IV	n/a	
		Rated mains voltage ≤ 1000 V _{RMS}	I-III	n/a	
DIN EN IEC 60747-17 (VDE 0884-17)⁽²⁾					
V _{IORM}	Maximum repetitive peak isolation voltage	AC voltage (bipolar)	2121	566	V _{PK}
V _{IOWM}	Maximum working isolation voltage	AC voltage; Time dependent dielectric breakdown (TDDB) test; See Figure 8-7	1500	400	V _{RMS}
		DC voltage	2121	566	V _{DC}
V _{IOTM}	Maximum transient isolation voltage	V _{TEST} = V _{IOTM} , t = 60 s (qualification); V _{TEST} = 1.2 x V _{IOTM} , t = 1 s (100% production)	8000	4242	V _{PK}
V _{IMP}	Maximum impulse voltage ⁽³⁾	Tested in air, 1.2/50-μs waveform per IEC 62368-1	8000	4000	V _{PK}
V _{IOSM}	Maximum surge isolation voltage ⁽⁴⁾	V _{IOSM} ≥ 1.3 x V _{IMP} ; Tested in oil (qualification test), 1.2/50-μs waveform per IEC 62368-1	12800	10000	V _{PK}
q _{pd}	Apparent charge ⁽⁵⁾	Method a, After Input-output safety test subgroup 2/3, V _{ini} = V _{IOTM} , t _{ini} = 60 s; V _{pd(m)} = 1.2 x V _{IORM} , t _m = 10 s	≤5	≤5	pC
		Method a, After environmental tests subgroup 1, V _{ini} = V _{IOTM} , t _{ini} = 60 s; V _{pd(m)} = 1.6 x V _{IORM} , t _m = 10 s	≤5	≤5	
		Method b: At routine test (100% production) and preconditioning (type test); V _{ini} = 1.2 x V _{IOTM} , t _{ini} = 1 s; V _{pd(m)} = 1.875 x V _{IORM} , t _m = 1 s (method b1) or V _{pd(m)} = V _{ini} , t _m = t _{ini} (method b2)	≤5	≤5	
C _{IO}	Barrier capacitance, input to output ⁽⁶⁾	V _{IO} = 0.4 x sin(2πft), f = 1 MHz	~1.1	~0.9	pF
R _{IO}	Isolation resistance ⁽⁶⁾	V _{IO} = 500 V, T _A = 25°C	>10 ¹²	>10 ¹²	Ω
		V _{IO} = 500 V, 100°C ≤ T _A ≤ 125°C	>10 ¹¹	>10 ¹¹	
		V _{IO} = 500 V, T _S = 150°C	>10 ⁹	>10 ⁹	
	Pollution degree		2	2	
	Climatic category		55/125/ 21	55/125/ 21	
UL 1577					
V _{ISO}	Maximum withstanding isolation voltage	V _{TEST} = V _{ISO} , t = 60 s (qualification), V _{TEST} = 1.2 x V _{ISO} , t = 1 s (100% production)	5000	3000	V _{RMS}

- (1) Creepage and clearance requirements should be applied according to the specific equipment isolation standards of an application. Care should be taken to maintain the creepage and clearance distance of a board design to ensure that the mounting pads of the isolator on the printed-circuit board do not reduce this distance. Creepage and clearance on a printed-circuit board become equal in certain cases. Techniques such as inserting grooves and/or ribs on a printed-circuit board are used to help increase these specifications.

- (2) This coupler is suitable for *safe electrical insulation* only within the safety ratings. Compliance with the safety ratings shall be ensured by means of suitable protective circuits.

ISO7760-Q1, ISO7761-Q1, ISO7762-Q1, ISO7763-Q1SLLSEU7D – NOVEMBER 2018 – REVISED JANUARY 2024

- (3) Testing is carried out in air to determine the surge immunity of the package
- (4) Testing is carried out in oil to determine the intrinsic surge immunity of the isolation barrier.
- (5) Apparent charge is electrical discharge caused by a partial discharge (pd).
- (6) All pins on each side of the barrier tied together creating a two-terminal device.

6.7 Safety-Related Certifications

VDE	CSA	UL	CQC	TUV
Certified according to DIN EN IEC 60747-17 (VDE 0884-17)	Certified according to IEC 62368-1 and IEC 60601-1	Recognized under UL 1577 Component Recognition Program	Certified according to GB 4943.1	Certified according to EN 61010-1 and EN 62368-1
Reinforced Insulation; Maximum transient isolation voltage, 8000 V _{PK} (ISO7760 in DW-16), 7071 V _{PK} (ISO7761, ISO7762, ISO7763 in DW-16) and 4242 V _{PK} (DBQ-16); Maximum repetitive peak isolation voltage, 2121 V _{PK} (DW-16) and 566 V _{PK} (DBQ-16); Maximum surge isolation voltage, 12800 V _{PK} (DW-16) and 10000 V _{PK} (DBQ-16)	Reinforced insulation per CSA 62368-1 and IEC 62368-1 800 V _{RMS} (DW-16) and 370 V _{RMS} (DBQ-16) maximum working voltage (pollution degree 2, material group I); DW-16: 2 MOPP (Means of Patient Protection) per CSA 60601-1 and IEC 60601-1, 250 V _{RMS} maximum working voltage	DW-16: Single protection, 5000 V _{RMS} ; DBQ-16: Single protection, 3000 V _{RMS}	DW-16: Reinforced Insulation, Altitude ≤ 5000 m, Tropical Climate, 700 V _{RMS} maximum working voltage; DBQ-16: Basic Insulation, Altitude ≤ 5000 m, Tropical Climate, 400 V _{RMS} maximum working voltage	5000 V _{RMS} Reinforced insulation per EN 61010-1 up to working voltage of 600 V _{RMS} (DW-16) and 300 V _{RMS} (DBQ-16) 5000 V _{RMS} Reinforced insulation per EN 62368-1 up to working voltage of 600 V _{RMS} (DW-16) and 370 V _{RMS} (DBQ-16)
Certificate number: 40040142	Master contract number: 220991	File number: E181974	Certificate numbers: CQC15001121716 (DW) CQC18001199097 (DBQ)	Client ID number: 77311

6.8 Safety Limiting Values

Safety limiting⁽¹⁾ intends to minimize potential damage to the isolation barrier upon failure of input or output circuitry.

PARAMETER		TEST CONDITIONS	MIN	TYP	MAX	UNIT
DW-16 PACKAGE						
I _S	Safety input, output, or supply current ⁽¹⁾	R _{θJA} = 60.3°C/W, V _I = 5.5 V, T _J = 150°C, T _A = 25°C, see Figure 6-1			377	mA
		R _{θJA} = 60.3°C/W, V _I = 3.6 V, T _J = 150°C, T _A = 25°C, see Figure 6-1			576	
		R _{θJA} = 60.3°C/W, V _I = 2.75 V, T _J = 150°C, T _A = 25°C, see Figure 6-1			754	
P _S	Safety input, output, or total power ⁽¹⁾	R _{θJA} = 60.3°C/W, T _J = 150°C, T _A = 25°C, see Figure 6-1			2073	mW
T _S	Maximum safety temperature ⁽¹⁾				150	°C
DBQ-16 PACKAGE						
I _S	Safety input, output, or supply current ⁽¹⁾	R _{θJA} = 86.5°C/W, V _I = 5.5 V, T _J = 150°C, T _A = 25°C, see Figure 6-2			263	mA
		R _{θJA} = 86.5°C/W, V _I = 3.6 V, T _J = 150°C, T _A = 25°C, see Figure 6-2			401	
		R _{θJA} = 86.5°C/W, V _I = 2.75 V, T _J = 150°C, T _A = 25°C, see Figure 6-2			525	
P _S	Safety input, output, or total power ⁽¹⁾	R _{θJA} = 86.5°C/W, T _J = 150°C, T _A = 25°C, see Figure 6-2			1445	mW
T _S	Maximum safety temperature ⁽¹⁾				150	°C

(1) The maximum safety temperature, T_S, has the same value as the maximum junction temperature, T_J, specified for the device. The I_S and P_S parameters represent the safety current and safety power respectively. The maximum limits of I_S and P_S should not be exceeded. These limits vary with the ambient temperature, T_A.

The junction-to-air thermal resistance, R_{θJA}, in the table is that of a device installed on a high-K test board for leaded surface-mount packages. Use these equations to calculate the value for each parameter:

T_J = T_A + R_{θJA} × P, where P is the power dissipated in the device.

T_{J(max)} = T_S = T_A + R_{θJA} × P_S, where T_{J(max)} is the maximum allowed junction temperature.

$P_S = I_S \times V_I$, where V_I is the maximum input voltage.

6.9 Electrical Characteristics—5-V Supply

VCC1 = VCC2 = 5 V ± 10% (over recommended operating conditions unless otherwise noted)

PARAMETER		TEST CONDITIONS	MIN	TYP	MAX	UNIT
V _{OH}	High-level output voltage	I _{OH} = -4 mA; See Figure 7-1	V _{CCO} ⁽¹⁾ - 0.4	4.8		V
V _{OL}	Low-level output voltage	I _{OL} = 4 mA; See Figure 7-1		0.2	0.4	V
V _{IT+(IN)}	Rising input switching threshold			0.6 x V _{CCI}	0.7 x V _{CCI}	V
V _{IT-(IN)}	Falling input switching threshold		0.3 x V _{CCI}	0.4 x V _{CCI}		V
V _{I(HYS)}	Input threshold voltage hysteresis		0.1 x V _{CCI}	0.2 x V _{CCI}		V
I _{IH}	High-level input current	V _{IH} = V _{CCI} ⁽¹⁾ at INx			10	μA
I _{IL}	Low-level input current	V _{IL} = 0 V at INx	-10			μA
CMTI	Common mode transient immunity	V _I = V _{CCI} or 0 V, V _{CM} = 1200 V; See Figure 7-3	85	100		kV/μs
C _I	Input Capacitance ⁽²⁾	V _I = V _{CC} / 2 + 0.4 × sin(2πft), f = 1 MHz, V _{CC} = 5 V		2		pF

(1) V_{CCI} = Input-side V_{CC}; V_{CCO} = Output-side V_{CC}

(2) Measured from input pin to same side ground.

6.10 Supply Current Characteristics—5-V Supply

VCC1 = VCC2 = 5 V ± 10% (over recommended operating conditions unless otherwise noted).

PARAMETER	TEST CONDITIONS	SUPPLY CURRENT	MIN	TYP	MAX	UNIT	
ISO7760-Q1							
Supply current - DC signal	V _I = V _{CC1} (ISO7760-Q1); V _I = 0 V (ISO7760-Q1 with F suffix)	I _{CC1}		1.6	2.9	mA	
		I _{CC2}		3	5.3		
	V _I = 0 V (ISO7760-Q1); V _I = V _{CC1} (ISO7760-Q1 with F suffix)	I _{CC1}		8	11.3		
		I _{CC2}		3.3	5.7		
Supply current - AC signal	All channels switching with square wave clock input; C _L = 15 pF	1 Mbps	I _{CC1}		5		6.5
			I _{CC2}		3.5		5.9
		10 Mbps	I _{CC1}		5.2		6.7
			I _{CC2}		6.4		9.7
		100 Mbps	I _{CC1}		7	9.2	
			I _{CC2}		35	47	
ISO7761-Q1							
Supply current - DC signal	V _I = V _{CCI} ⁽¹⁾ (ISO7761-Q1); V _I = 0 V (ISO7761-Q1 with F suffix)	I _{CC1}		1.9	3.5	mA	
		I _{CC2}		2.9	5.4		
	V _I = 0 V (ISO7761-Q1); V _I = V _{CCI} (ISO7761-Q1 with F suffix)	I _{CC1}		7.3	10.6		
		I _{CC2}		4.2	6.9		
Supply current - AC signal	All channels switching with square wave clock input; C _L = 15 pF	1 Mbps	I _{CC1}		4.7		6.6
			I _{CC2}		3.8		6.5
		10 Mbps	I _{CC1}		5.3		8
			I _{CC2}		6.3		9.6
		100 Mbps	I _{CC1}		11.5	15.6	
			I _{CC2}		30.5	40.3	
ISO7762-Q1							

ISO7760-Q1, ISO7761-Q1, ISO7762-Q1, ISO7763-Q1

SLLSEU7D – NOVEMBER 2018 – REVISED JANUARY 2024

 $V_{CC1} = V_{CC2} = 5\text{ V} \pm 10\%$ (over recommended operating conditions unless otherwise noted).

PARAMETER	TEST CONDITIONS	SUPPLY CURRENT	MIN	TYP	MAX	UNIT	
Supply current - DC signal	$V_I = V_{CCI}$ (ISO7762-Q1); $V_I = 0\text{ V}$ (ISO7762-Q1 with F suffix)	I_{CC1}		2.1	4.1	mA	
		I_{CC2}		2.6	4.9		
	$V_I = 0\text{ V}$ (ISO7762-Q1); $V_I = V_{CCI}$ (ISO7762-Q1 with F suffix)	I_{CC1}		6.5	9.3		
		I_{CC2}		5	7.6		
Supply current - AC signal	All channels switching with square wave clock input; $C_L = 15\text{ pF}$	1 Mbps	I_{CC1}		4.5		6.7
			I_{CC2}		4		6.5
		10 Mbps	I_{CC1}		5.6		8
			I_{CC2}		6		8.9
		100 Mbps	I_{CC1}		16.5	21.3	
			I_{CC2}		25.7	34	
ISO7763-Q1							
Supply current - DC signal	$V_I = V_{CCI}$ (ISO7763-Q1); $V_I = 0\text{ V}$ (ISO7763-Q1 with F suffix)	I_{CC1}, I_{CC2}		2.4	4.7	mA	
		I_{CC1}, I_{CC2}		5.7	8.6		
Supply current - AC signal	All channels switching with square wave clock input; $C_L = 15\text{ pF}$	1 Mbps	I_{CC1}, I_{CC2}		4.2		6.8
			I_{CC1}, I_{CC2}		5.8		8.7
		10 Mbps	I_{CC1}, I_{CC2}		21		28.4
			I_{CC1}, I_{CC2}				

 (1) $V_{CCI} = \text{Input-side } V_{CC}$

6.11 Electrical Characteristics—3.3-V Supply

$V_{CC1} = V_{CC2} = 3.3\text{ V} \pm 10\%$ (over recommended operating conditions unless otherwise noted).

PARAMETER		TEST CONDITIONS	MIN	TYP	MAX	UNIT
V_{OH}	High-level output voltage	$I_{OH} = -2\text{mA}$; See Figure 7-1	$V_{CCO}^{(1)} - 0.3$	3.2		V
V_{OL}	Low-level output voltage	$I_{OL} = 2\text{mA}$; See Figure 7-1		0.1	0.3	V
$V_{IT+(IN)}$	Rising input switching threshold			$0.6 \times V_{CCI}$	$0.7 \times V_{CCI}^{(1)}$	V
$V_{IT-(IN)}$	Falling input switching threshold		$0.3 \times V_{CCI}$	$0.4 \times V_{CCI}$		V
$V_{I(HYS)}$	Input threshold voltage hysteresis		$0.1 \times V_{CCI}$	$0.2 \times V_{CCI}$		V
I_{IH}	High-level input current	$V_{IH} = V_{CCI}^{(1)}$ at INx			10	μA
I_{IL}	Low-level input current	$V_{IL} = 0\text{ V}$ at INx	-10			μA
CMTI	Common mode transient immunity	$V_I = V_{CC}$ or 0 V , $V_{CM} = 1200\text{ V}$; See Figure 7-3	85	100		kV/us

(1) V_{CCI} = Input-side V_{CC} ; V_{CCO} = Output-side V_{CC}

6.12 Supply Current Characteristics—3.3-V Supply

$V_{CC1} = V_{CC2} = 3.3\text{ V} \pm 10\%$ (over recommended operating conditions unless otherwise noted).

PARAMETER	TEST CONDITIONS		SUPPLY CURRENT	MIN	TYP	MAX	UNIT
ISO7760-Q1							
Supply current - DC signal	$V_I = V_{CC1}$ (ISO7760-Q1); $V_I = 0\text{ V}$ (ISO7760-Q1 with F suffix)		I_{CC1}		1.6	2.9	mA
			I_{CC2}		3	5.3	
	$V_I = 0\text{ V}$ (ISO7760-Q1); $V_I = V_{CC1}$ (ISO7760-Q1 with F suffix)		I_{CC1}		8	11.4	
			I_{CC2}		3.3	5.7	
Supply current - AC signal	All channels switching with square wave clock input; $C_L = 15\text{ pF}$	1 Mbps	I_{CC1}		4.9	6.4	
			I_{CC2}		3.4	5.7	
		10 Mbps	I_{CC1}		5	6.6	
			I_{CC2}		5.5	8.5	
		100 Mbps	I_{CC1}		6.3	8.1	
			I_{CC2}		26	35	
ISO7761-Q1							
Supply current - DC signal	$V_I = V_{CC1}^{(1)}$ (ISO7761-Q1); $V_I = 0\text{ V}$ (ISO7761-Q1 with F suffix)		I_{CC1}		1.8	3.5	mA
			I_{CC2}		2.9	5.3	
	$V_I = 0\text{ V}$ (ISO7761-Q1); $V_I = V_{CC1}$ (ISO7761-Q1 with F suffix)		I_{CC1}		7.2	10.3	
			I_{CC2}		4.2	6.9	
Supply current - AC signal	All channels switching with square wave clock input; $C_L = 15\text{ pF}$	1 Mbps	I_{CC1}		4.6	6.5	
			I_{CC2}		3.7	6.3	
		10 Mbps	I_{CC1}		5.1	7.5	
			I_{CC2}		5.5	8.6	
		100 Mbps	I_{CC1}		9.4	12.7	
			I_{CC2}		22.8	30.5	
ISO7762-Q1							

$V_{CC1} = V_{CC2} = 3.3\text{ V} \pm 10\%$ (over recommended operating conditions unless otherwise noted).

PARAMETER	TEST CONDITIONS	SUPPLY CURRENT	MIN	TYP	MAX	UNIT	
Supply current - DC signal	$V_I = V_{CCI}$ (ISO7762-Q1); $V_I = 0\text{ V}$ (ISO7762-Q1 with F suffix)	I_{CC1}		2.1	4	mA	
		I_{CC2}		2.5	4.8		
	$V_I = 0\text{ V}$ (ISO7762-Q1); $V_I = V_{CCI}$ (ISO7762-Q1 with F suffix)	I_{CC1}		6.5	9.4		
		I_{CC2}		5	7.5		
Supply current - AC signal	All channels switching with square wave clock input; $C_L = 15\text{ pF}$	1 Mbps	I_{CC1}		4.4		6.6
			I_{CC2}		3.9		6.3
		10 Mbps	I_{CC1}		5.2		7.5
			I_{CC2}		5.4		8.1
		100 Mbps	I_{CC1}		12.9	16.9	
			I_{CC2}		19.5	26	
ISO7763-Q1							
Supply current - DC signal	$V_I = V_{CCI}$ (ISO7763-Q1); $V_I = 0\text{ V}$ (ISO7763-Q1 with F suffix)	I_{CC1}, I_{CC2}		2.4	4.6	mA	
		I_{CC1}, I_{CC2}		5.7	8.4		
Supply current - AC signal	All channels switching with square wave clock input; $C_L = 15\text{ pF}$	1 Mbps	I_{CC1}, I_{CC2}		4.2		6.6
			I_{CC1}, I_{CC2}		5.2		8.1
		10 Mbps	I_{CC1}, I_{CC2}		16		21.9
			I_{CC1}, I_{CC2}				

(1) $V_{CCI} = \text{Input-side } V_{CC}$

6.13 Electrical Characteristics—2.5-V Supply

$V_{CC1} = V_{CC2} = 2.5\text{ V} \pm 10\%$ (over recommended operating conditions unless otherwise noted).

PARAMETER		TEST CONDITIONS	MIN	TYP	MAX	UNIT
V_{OH}	High-level output voltage	$I_{OH} = -1\text{ mA}$; See Figure 7-1	$V_{CCO}^{(1)} - 0.2$	2.45		V
V_{OL}	Low-level output voltage	$I_{OL} = 1\text{ mA}$; See Figure 7-1		0.05	0.2	V
$V_{IT+(IN)}$	Rising input switching threshold			$0.6 \times V_{CCI}$	$0.7 \times V_{CCI}^{(1)}$	V
$V_{IT-(IN)}$	Falling input switching threshold		$0.3 \times V_{CCI}$	$0.4 \times V_{CCI}$		V
$V_{I(HYS)}$	Input threshold voltage hysteresis		$0.1 \times V_{CCI}$	$0.2 \times V_{CCI}$		V
I_{IH}	High-level input current	$V_{IH} = V_{CCI}^{(1)}$ at INx			10	μA
I_{IL}	Low-level input current	$V_{IL} = 0\text{ V}$ at INx	-10			μA
CMTI	Common mode transient immunity	$V_I = V_{CC}$ or 0 V , $V_{CM} = 1200\text{ V}$; See Figure 7-3	85	100		kV/us

(1) V_{CCI} = Input-side V_{CC} ; V_{CCO} = Output-side V_{CC}

6.14 Supply Current Characteristics—2.5-V Supply

$V_{CC1} = V_{CC2} = 2.5\text{ V} \pm 10\%$ (over recommended operating conditions unless otherwise noted).

PARAMETER	TEST CONDITIONS		SUPPLY CURRENT	MIN	TYP	MAX	UNIT
ISO7760-Q1							
Supply current - DC signal	$V_I = V_{CC1}$ (ISO7760-Q1); $V_I = 0\text{ V}$ (ISO7760-Q1 with F suffix)		I_{CC1}		1.6	2.9	mA
			I_{CC2}		3	5.2	
	$V_I = 0\text{ V}$ (ISO7760-Q1); $V_I = V_{CC1}$ (ISO7760-Q1 with F suffix)		I_{CC1}		8	11.6	
			I_{CC2}		3.3	5.7	
Supply current - AC signal	All channels switching with square wave clock input; $C_L = 15\text{ pF}$	1 Mbps	I_{CC1}		4.9	6.4	
			I_{CC2}		3.4	5.7	
		10 Mbps	I_{CC1}		5	6.5	
			I_{CC2}		4.9	7.7	
		100 Mbps	I_{CC1}		6	7.7	
			I_{CC2}		20.3	27.9	
ISO7761-Q1							
Supply current - DC signal	$V_I = V_{CC1}^{(1)}$ (ISO7761-Q1); $V_I = 0\text{ V}$ (ISO7761-Q1 with F suffix)		I_{CC1}		1.8	3.4	mA
			I_{CC2}		2.9	5.3	
	$V_I = 0\text{ V}$ (ISO7761-Q1); $V_I = V_{CC1}$ (ISO7761-Q1 with F suffix)		I_{CC1}		7.2	10.3	
			I_{CC2}		4.2	6.8	
Supply current - AC signal	All channels switching with square wave clock input; $C_L = 15\text{ pF}$	1 Mbps	I_{CC1}		4.6	6.5	
			I_{CC2}		3.7	6.3	
		10 Mbps	I_{CC1}		4.9	7.2	
			I_{CC2}		5	7.9	
		100 Mbps	I_{CC1}		8.3	11.2	
			I_{CC2}		18.1	24.6	
ISO7762-Q1							

$V_{CC1} = V_{CC2} = 2.5\text{ V} \pm 10\%$ (over recommended operating conditions unless otherwise noted).

PARAMETER	TEST CONDITIONS	SUPPLY CURRENT	MIN	TYP	MAX	UNIT
Supply current - DC signal	$V_I = V_{CCI}$ (ISO7762-Q1); $V_I = 0\text{ V}$ (ISO7762-Q1 with F suffix)	I_{CC1}		2.1	4	mA
		I_{CC2}		2.6	4.8	
	$V_I = 0\text{ V}$ (ISO7762-Q1); $V_I = V_{CCI}$ (ISO7762-Q1 with F suffix)	I_{CC1}		6.5	9.6	
		I_{CC2}		4.9	7.4	
Supply current - AC signal	All channels switching with square wave clock input; $C_L = 15\text{ pF}$	1 Mbps	I_{CC1}	4.4	6.5	
			I_{CC2}	3.9	6.3	
		10 Mbps	I_{CC1}	5	7.2	
			I_{CC2}	5	7.6	
		100 Mbps	I_{CC1}	10.9	14.4	
			I_{CC2}	15.6	21.3	
ISO7763-Q1						
Supply current - DC signal	$V_I = V_{CCI}$ (ISO7763-Q1); $V_I = 0\text{ V}$ (ISO7763-Q1 with F suffix)	I_{CC1}, I_{CC2}		2.3	4.6	mA
		I_{CC1}, I_{CC2}		5.7	8.4	
Supply current - AC signal	All channels switching with square wave clock input; $C_L = 15\text{ pF}$	1 Mbps	I_{CC1}, I_{CC2}	4.1	6.6	
		10 Mbps	I_{CC1}, I_{CC2}	4.9	7.6	
		100 Mbps	I_{CC1}, I_{CC2}	13	18.1	

(1) $V_{CCI} = \text{Input-side } V_{CC}$

6.15 Switching Characteristics—5-V Supply

$V_{CC1} = V_{CC2} = 5\text{ V} \pm 10\%$ (over recommended operating conditions unless otherwise noted)

PARAMETER		TEST CONDITIONS	MIN	TYP	MAX	UNIT
ISO776x-Q1						
t_{PLH}, t_{PHL}	Propagation delay time	See Figure 7-1	6	11	17	ns
PWD	Pulse width distortion ⁽¹⁾ $ t_{PHL} - t_{PLH} $		0.4	5.9	ns	
$t_{sk(o)}$	Channel-to-channel output skew time ⁽²⁾	Same-direction channels			4	ns
$t_{sk(pp)}$	Part-to-part skew time ⁽³⁾				4.5	ns
t_r	Output signal rise time	See Figure 7-1		1.1	3.9	ns
t_f	Output signal fall time			1.4	3.9	ns
t_{DO}	Default output delay time from input power loss	Measured from the time V_{CC} goes below 1.7V. See Figure 7-2		0.2	0.3	μs
t_{ie}	Time interval error	$2^{16} - 1$ PRBS data at 100 Mbps		1.3		ns

- (1) Also known as pulse skew.
- (2) $t_{sk(o)}$ is the skew between outputs of a single device with all driving inputs connected together and the outputs switching in the same direction while driving identical loads.
- (3) $t_{sk(pp)}$ is the magnitude of the difference in propagation delay times between any terminals of different devices switching in the same direction while operating at identical supply voltages, temperature, input signals and loads.

6.16 Switching Characteristics—3.3-V Supply

$V_{CC1} = V_{CC2} = 3.3\text{ V} \pm 10\%$ (over recommended operating conditions unless otherwise noted)

PARAMETER		TEST CONDITIONS	MIN	TYP	MAX	UNIT
ISO776x-Q1						
t_{PLH}, t_{PHL}	Propagation delay time	See Figure 7-1	6	12	18.5	ns
PWD	Pulse width distortion ⁽¹⁾ $ t_{PHL} - t_{PLH} $					
$t_{sk(o)}$	Channel-to-channel output skew time ⁽²⁾	Same-direction channels			4.4	ns
$t_{sk(pp)}$	Part-to-part skew time ⁽³⁾				5	ns
t_r	Output signal rise time	See Figure 7-1		1	3	ns
t_f	Output signal fall time			1	3	ns
t_{DO}	Default output delay time from input power loss	Measured from the time V_{CC} goes below 1.7V. See Figure 7-2		0.2	0.3	μs
t_{ie}	Time interval error	$2^{16} - 1$ PRBS data at 100 Mbps		1.3		ns

- (1) Also known as pulse skew.
- (2) $t_{sk(o)}$ is the skew between outputs of a single device with all driving inputs connected together and the outputs switching in the same direction while driving identical loads.
- (3) $t_{sk(pp)}$ is the magnitude of the difference in propagation delay times between any terminals of different devices switching in the same direction while operating at identical supply voltages, temperature, input signals and loads.

6.17 Switching Characteristics—2.5-V Supply

$V_{CC1} = V_{CC2} = 2.5\text{ V} \pm 10\%$ (over recommended operating conditions unless otherwise noted)

PARAMETER		TEST CONDITIONS	MIN	TYP	MAX	UNIT
ISO776x-Q1						
t_{PLH}, t_{PHL}	Propagation delay time	See Figure 7-1	7.5	13	21	ns
PWD	Pulse width distortion ⁽¹⁾ $ t_{PHL} - t_{PLH} $		0.6	5.9	ns	
$t_{sk(o)}$	Channel-to-channel output skew time ⁽²⁾	Same-direction channels			4.4	ns
$t_{sk(pp)}$	Part-to-part skew time ⁽³⁾				5.3	ns
t_r	Output signal rise time	See Figure 7-1		1	3.5	ns
t_f	Output signal fall time		1	3.5	ns	
t_{DO}	Default output delay time from input power loss	Measured from the time V_{CC} goes below 1.7V. See Figure 7-2		0.1	0.3	μs
t_{ie}	Time interval error	$2^{16} - 1$ PRBS data at 100 Mbps		1.3		ns

- (1) Also known as pulse skew.
- (2) $t_{sk(o)}$ is the skew between outputs of a single device with all driving inputs connected together and the outputs switching in the same direction while driving identical loads.
- (3) $t_{sk(pp)}$ is the magnitude of the difference in propagation delay times between any terminals of different devices switching in the same direction while operating at identical supply voltages, temperature, input signals and loads.

6.18 Insulation Characteristics Curves

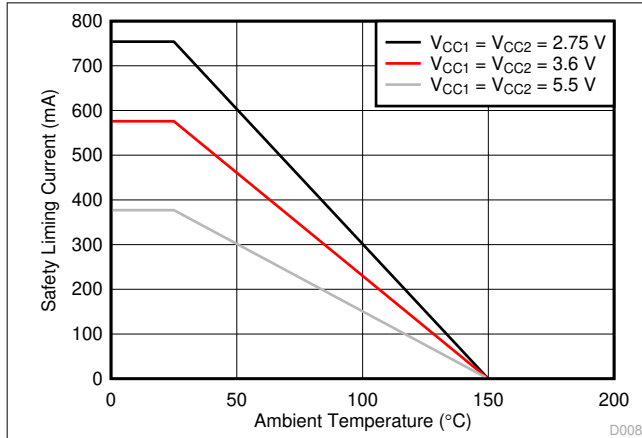

Figure 6-1. Thermal Derating Curve for Limiting Current per VDE for DW-16 Package

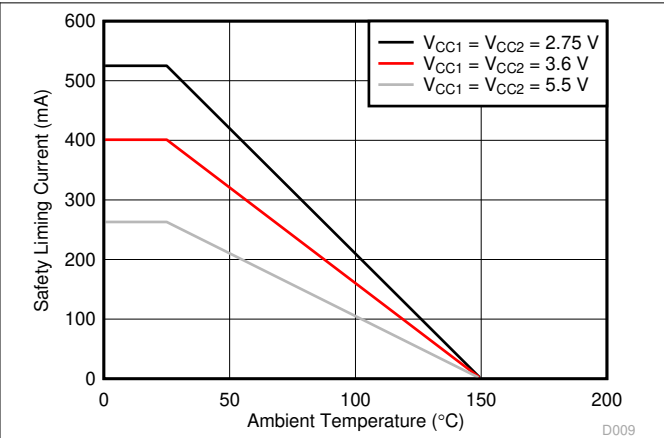

Figure 6-2. Thermal Derating Curve for Limiting Current per VDE for DBQ-16 Package

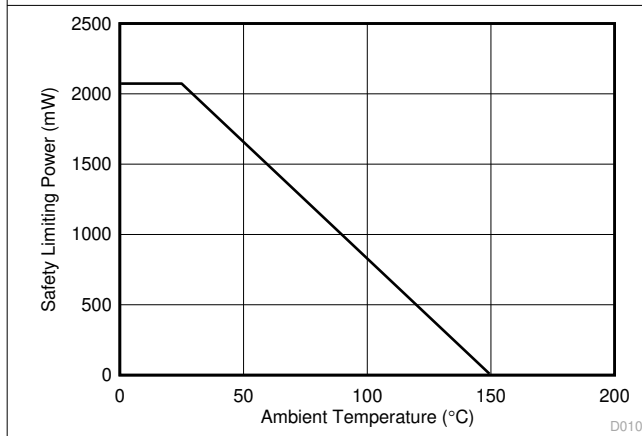

Figure 6-3. Thermal Derating Curve for Limiting Power per VDE for DW-16 Package

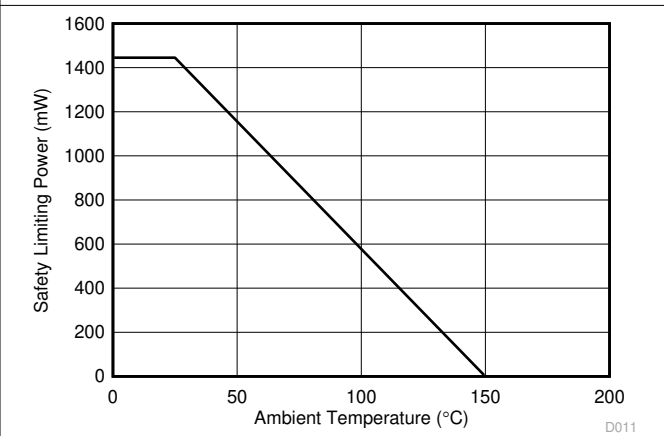

Figure 6-4. Thermal Derating Curve for Limiting Power per VDE for DBQ-16 Package

6.19 Typical Characteristics

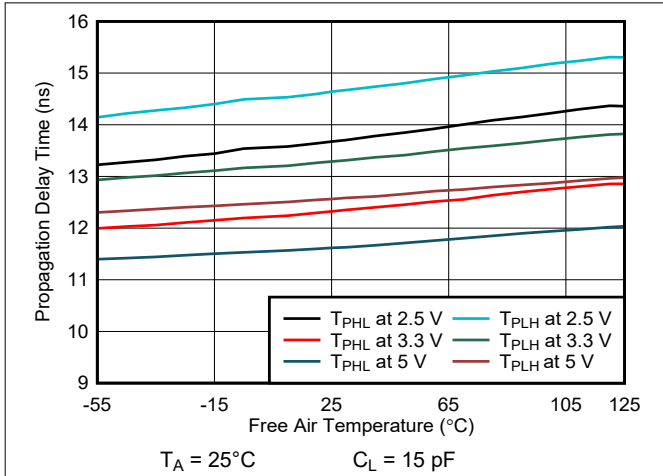

Figure 6-5. ISO7760-Q1 Supply Current vs Data Rate (With 15-pF Load)

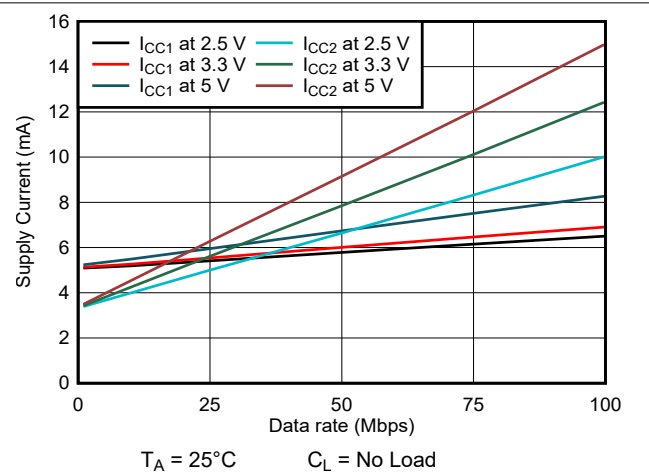

Figure 6-6. ISO7760-Q1 Supply Current vs Data Rate (With No Load)

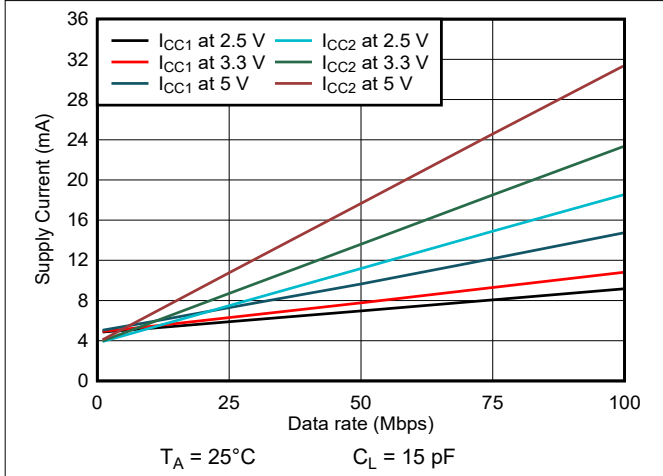

Figure 6-7. ISO7761-Q1 Supply Current vs Data Rate (With 15-pF Load)

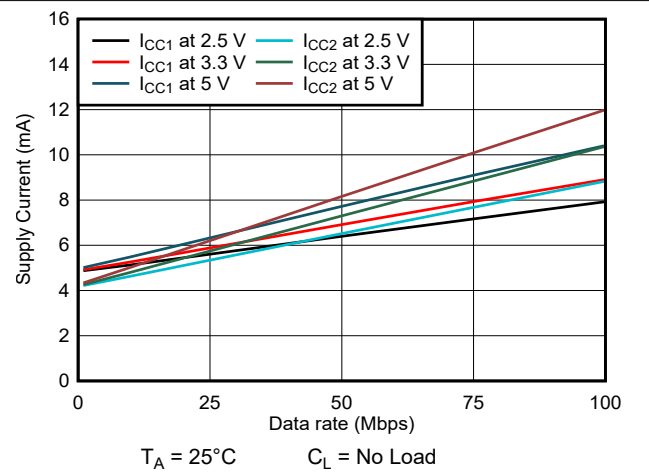

Figure 6-8. ISO7761-Q1 Supply Current vs Data Rate (With No Load)

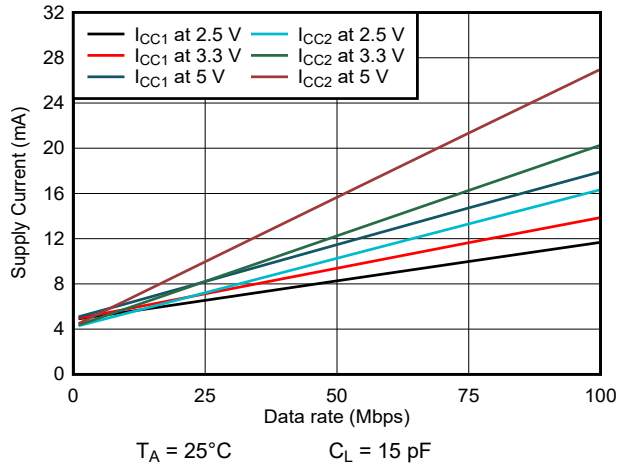

Figure 6-9. ISO7762-Q1 Supply Current vs Data Rate (With 15-pF Load)

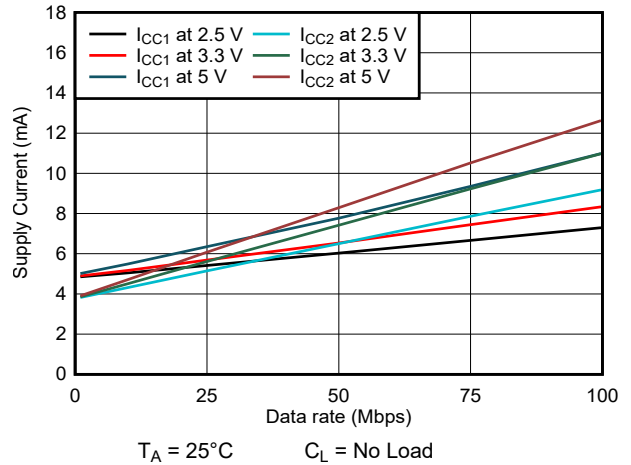

Figure 6-10. ISO7762-Q1 Supply Current vs Data Rate (With No Load)

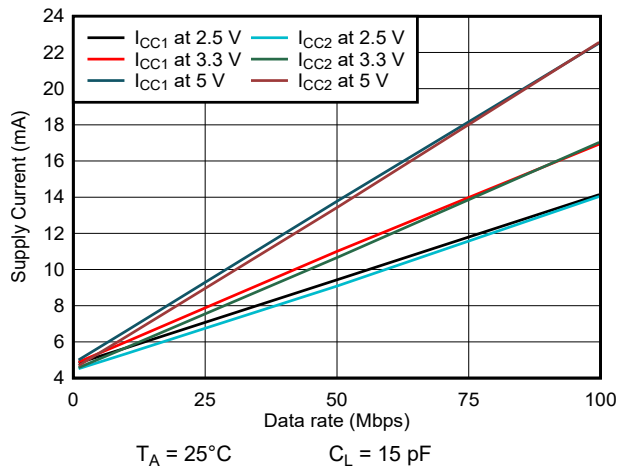

Figure 6-11. ISO7763-Q1 Supply Current vs Data Rate (With 15-pF Load)

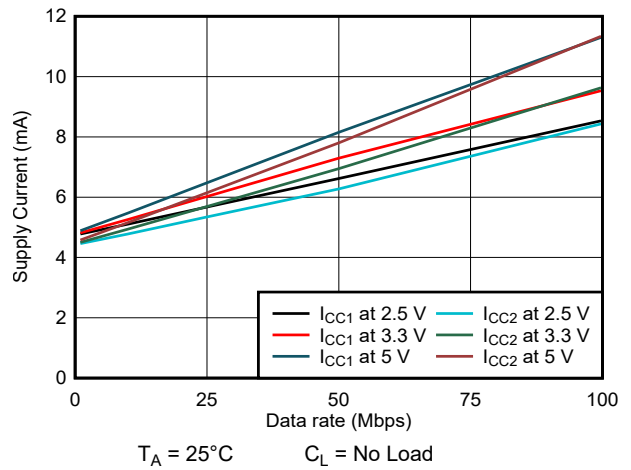

Figure 6-12. ISO7763-Q1 Supply Current vs Data Rate (With No Load)

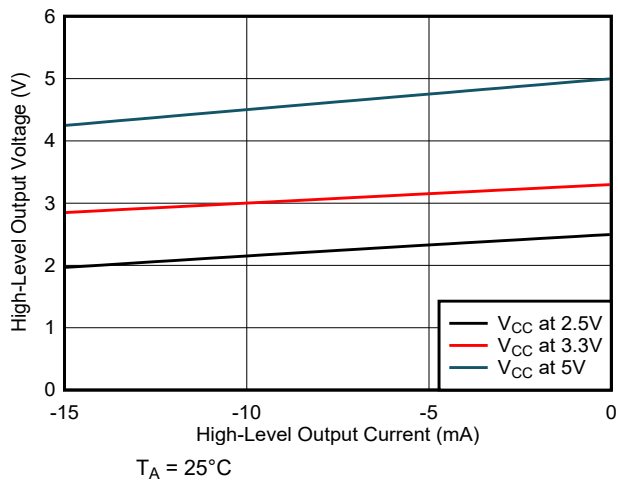

Figure 6-13. High-Level Output Voltage vs High-Level Output Current

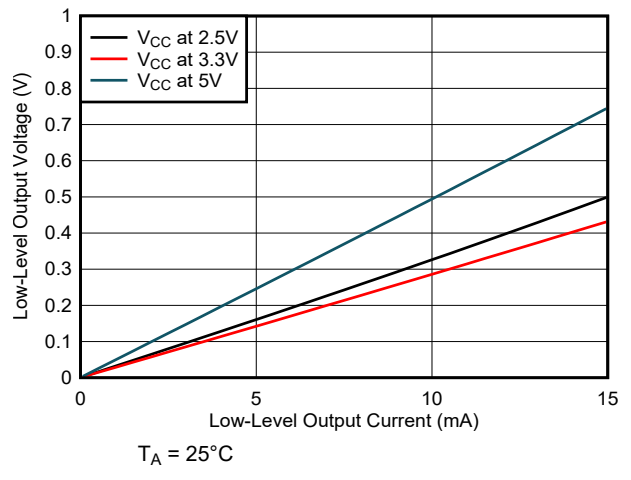

Figure 6-14. Low-Level Output Voltage vs Low-Level Output Current

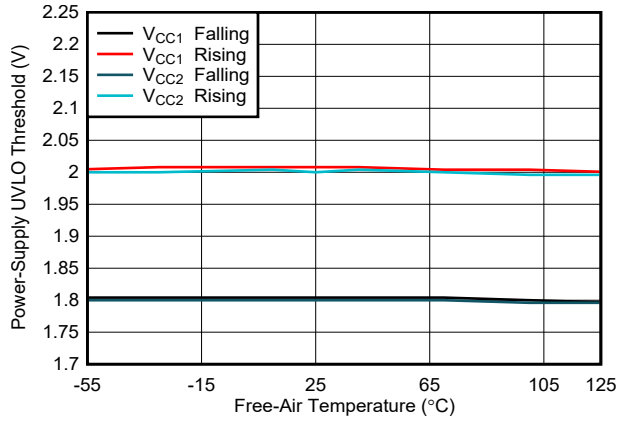

Figure 6-15. Power Supply Undervoltage Threshold vs Free-Air Temperature

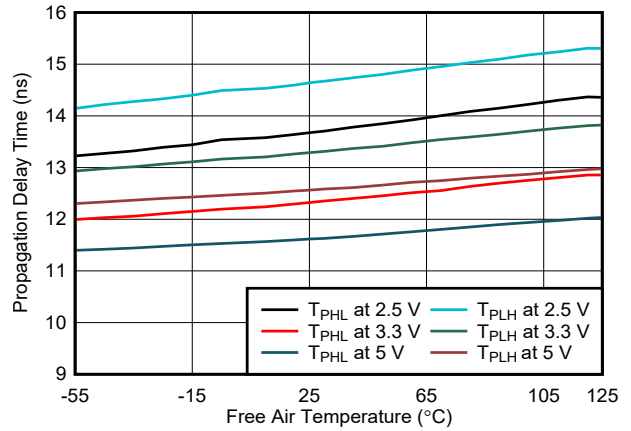

Figure 6-16. Propagation Delay Time vs Free-Air Temperature

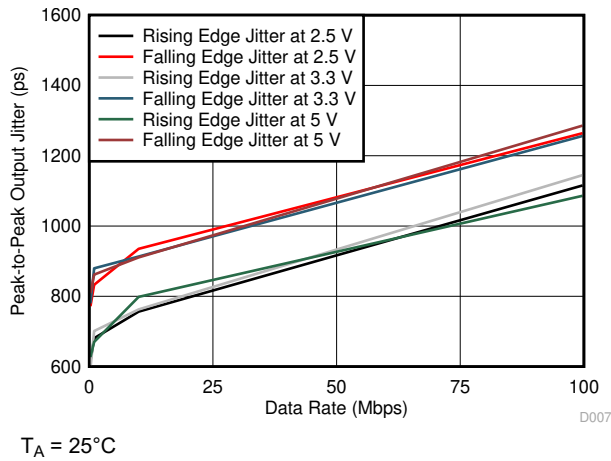
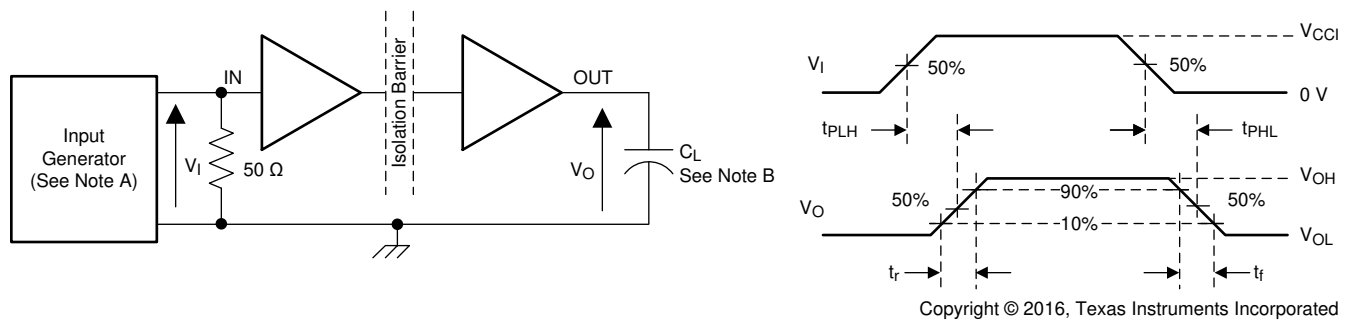

Figure 6-17. Peak-to-Peak Output Jitter vs Data Rate

Parameter Measurement Information



- A. The input pulse is supplied by a generator having the following characteristics: PRR ≤ 50 kHz, 50% duty cycle, $t_r \leq 3$ ns, $t_f \leq 3$ ns, $Z_O = 50 \Omega$. At the input, a 50- Ω resistor is required to terminate Input Generator signal. It is not needed in actual application.
- B. $C_L = 15$ pF and includes instrumentation and fixture capacitance within $\pm 20\%$.

Figure 7-1. Switching Characteristics Test Circuit and Voltage Waveforms

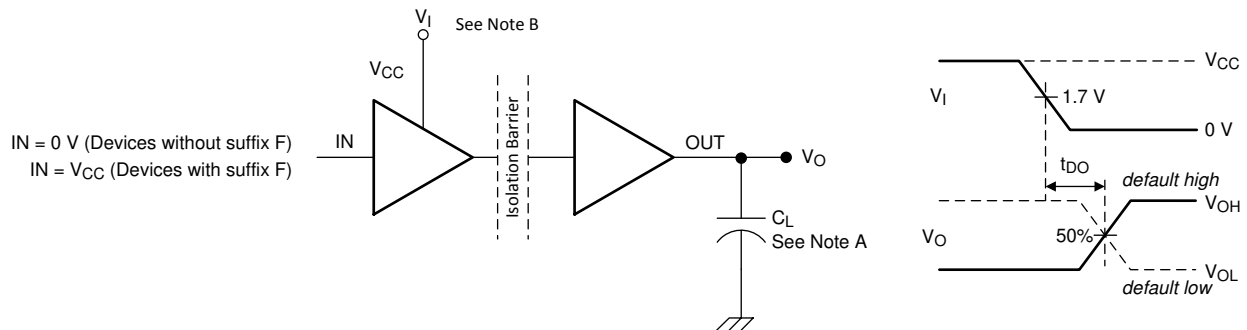

- A. $C_L = 15$ pF and includes instrumentation and fixture capacitance within $\pm 20\%$.
- B. Power-supply ramp rate = 10 mV/ns

Figure 7-2. Default Output Delay Time Test Circuit and Voltage Waveforms

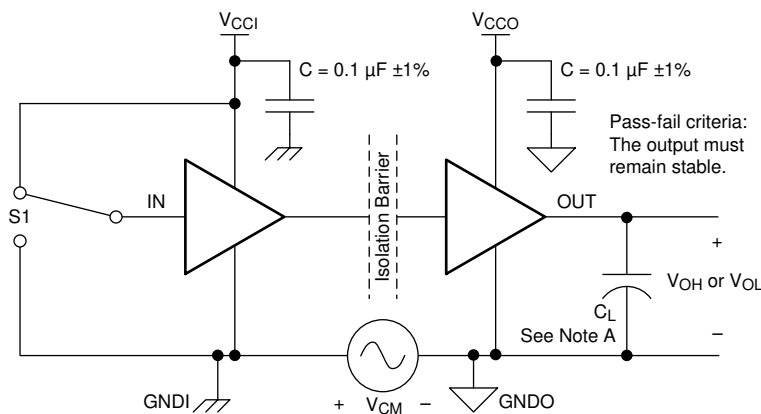

- A. $C_L = 15$ pF and includes instrumentation and fixture capacitance within $\pm 20\%$.

Figure 7-3. Common-Mode Transient Immunity Test Circuit

7 Detailed Description

7.1 Overview

The ISO776x-Q1 family of devices uses an ON-OFF keying (OOK) modulation scheme to transmit the digital data across a silicon-dioxide based isolation barrier. The transmitter sends a high-frequency carrier across the barrier to represent one digital state and sends no signal to represent the other digital state. The receiver demodulates the signal after advanced signal conditioning and produces the output through a buffer stage. The ISO776x-Q1 family of devices also incorporates advanced circuit techniques to maximize the CMTI performance and minimize the radiated emissions because of the high-frequency carrier and IO buffer switching. The conceptual block diagram of a digital capacitive isolator, [Figure 7-1](#), shows a functional block diagram of a typical channel. [Figure 7-2](#) shows a conceptual detail of how the ON-OFF keying scheme works.

7.2 Functional Block Diagram

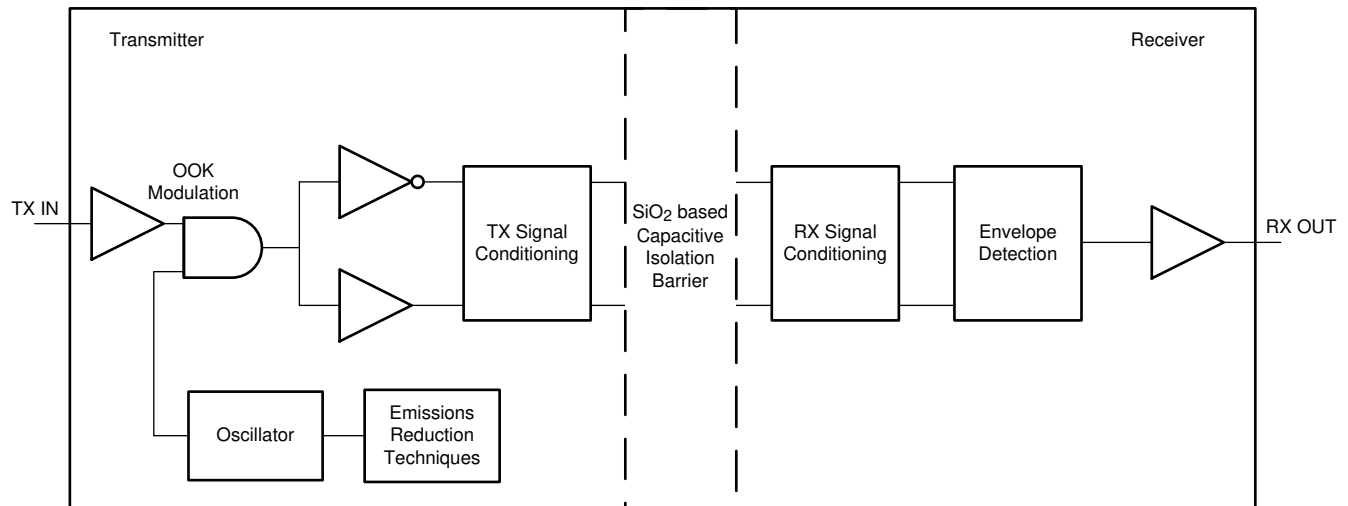

Copyright © 2016, Texas Instruments Incorporated

Figure 7-1. Conceptual Block Diagram of a Digital Capacitive Isolator

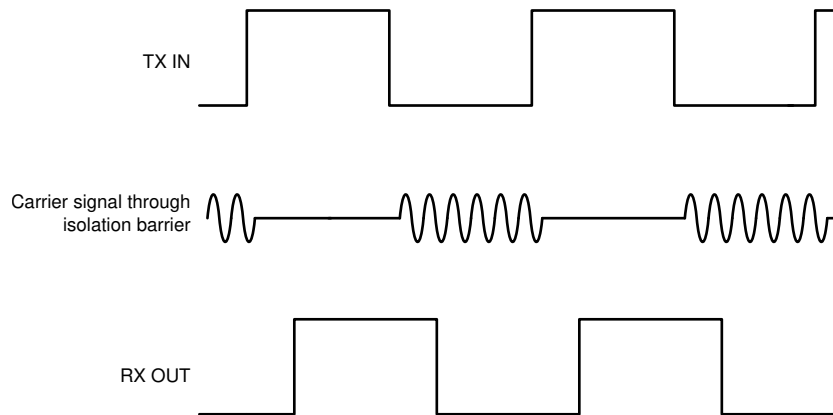

Figure 7-2. ON-OFF Keying (OOK) Based Modulation Scheme

7.3 Feature Description

Table 7-1 lists the device features.

Table 7-1. Device Features

PART NUMBER	CHANNEL DIRECTION	MAXIMUM DATA RATE	DEFAULT OUTPUT	PACKAGE	RATED ISOLATION ⁽¹⁾
ISO7760-Q1	6 Forward, 0 Reverse	100 Mbps	High	DW-16	5000 V _{RMS} / 8000 V _{PK}
				DBQ-16	3000 V _{RMS} / 4242 V _{PK}
ISO7760-Q1 with F suffix	6 Forward, 0 Reverse	100 Mbps	Low	DW-16	5000 V _{RMS} / 8000 V _{PK}
				DBQ-16	3000 V _{RMS} / 4242 V _{PK}
ISO7761-Q1	5 Forward, 1 Reverse	100 Mbps	High	DW-16	5000 V _{RMS} / 8000V _{PK}
				DBQ-16	3000 V _{RMS} / 4242 V _{PK}
ISO7761-Q1 with F suffix	5 Forward, 1 Reverse	100 Mbps	Low	DW-16	5000 V _{RMS} / 8000 V _{PK}
				DBQ-16	3000 V _{RMS} / 4242 V _{PK}
ISO7762-Q1	4 Forward, 2 Reverse	100 Mbps	High	DW-16	5000 V _{RMS} / 8000V _{PK}
				DBQ-16	3000 V _{RMS} / 4242 V _{PK}
ISO7762-Q1 with F suffix	4 Forward, 2 Reverse	100 Mbps	Low	DW-16	5000 V _{RMS} / 8000V _{PK}
				DBQ-16	3000 V _{RMS} / 4242 V _{PK}
ISO7763-Q1	3 Forward, 3 Reverse	100 Mbps	High	DW-16	5000 V _{RMS} / 8000V _{PK}
				DBQ-16	3000 V _{RMS} / 4242 V _{PK}
ISO7763-Q1 with F suffix	3 Forward, 3 Reverse	100 Mbps	Low	DW-16	5000 V _{RMS} / 8000 V _{PK}
				DBQ-16	3000 V _{RMS} / 4242 V _{PK}

(1) See [Section 6.7](#) for detailed isolation ratings.

7.3.1 Electromagnetic Compatibility (EMC) Considerations

Many applications in harsh industrial environment are sensitive to disturbances such as electrostatic discharge (ESD), electrical fast transient (EFT), surge and electromagnetic emissions. These electromagnetic disturbances are regulated by international standards such as IEC 61000-4-x and CISPR 22. Although system-level performance and reliability depends, to a large extent, on the application board design and layout, the ISO776x-Q1 family of devices incorporates many chip-level design improvements for overall system robustness. Some of these improvements include:

- Robust ESD protection for input and output signal pins and inter-chip bond pads.
- Low-resistance connectivity of ESD cells to supply and ground pins.
- Enhanced performance of high voltage isolation capacitor for better tolerance of ESD, EFT and surge events.
- Bigger on-chip decoupling capacitors to bypass undesirable high energy signals through a low impedance path.
- PMOS and NMOS devices isolated from each other by using guard rings to avoid triggering of parasitic SCRs.
- Reduced common mode currents across the isolation barrier by ensuring purely differential internal operation.

7.4 Device Functional Modes

Table 7-2 lists the functional modes for the ISO776x-Q1.

Table 7-2. Function Table

V_{CC1} ⁽¹⁾	V_{CC0}	INPUT (INx) ⁽³⁾	OUTPUT (OUTx)	COMMENTS
PU	PU	H	H	Normal Operation: A channel output assumes the logic state of the input.
		L	L	
		Open	Default	Default mode: When INx is open, the corresponding channel output goes to its default logic state. Default is <i>High</i> for ISO776x-Q1 and <i>Low</i> for ISO776x-Q1 with F suffix.
PD	PU	X	Default	Default mode: When V_{CC1} is unpowered, a channel output assumes the logic state based on the selected default option. Default is <i>High</i> for ISO776x-Q1 and <i>Low</i> for ISO776x-Q1 with F suffix. When V_{CC1} transitions from unpowered to powered-up, a channel output assumes the logic state of its input. When V_{CC1} transitions from powered-up to unpowered, channel output assumes the selected default state.
X	PD	X	Undetermined	When V_{CC0} is unpowered, a channel output is undetermined ⁽²⁾ . When V_{CC0} transitions from unpowered to powered-up, a channel output assumes the logic state of the input

(1) V_{CC1} = Input-side V_{CC} ; V_{CC0} = Output-side V_{CC} ; PU = Powered up ($V_{CC} \geq 2.25$ V); PD = Powered down ($V_{CC} \leq 1.7$ V); X = Irrelevant; H = High level; L = Low level

(2) The outputs are in undetermined state when 1.7 V < V_{CC1} , $V_{CC0} < 2.25$ V.

(3) A strongly driven input signal can weakly power the floating V_{CC} via an internal protection diode and cause undetermined output.

7.4.1 Device I/O Schematics

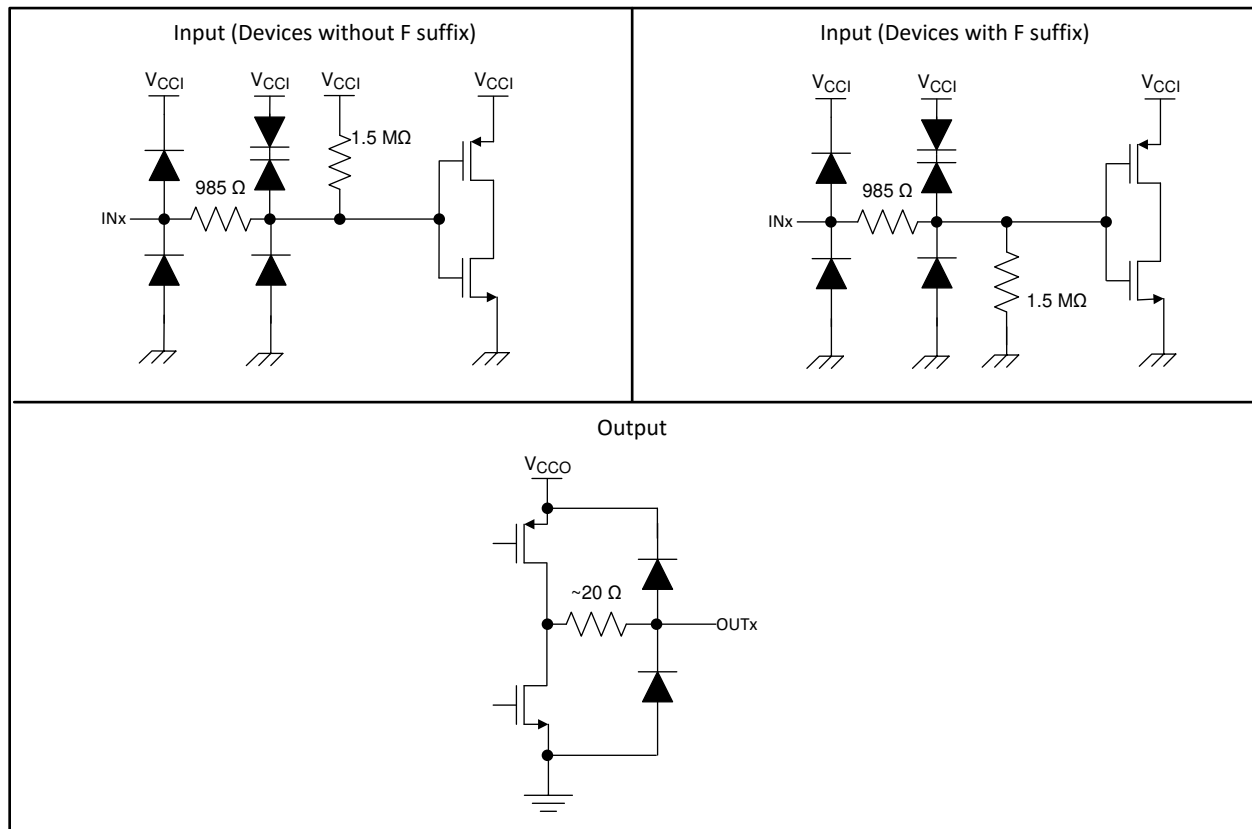

Copyright © 2016, Texas Instruments Incorporated

Figure 7-3. Device I/O Schematics

8 Application and Implementation

Note

Information in the following applications sections is not part of the TI component specification, and TI does not warrant its accuracy or completeness. TI's customers are responsible for determining suitability of components for their purposes. Customers should validate and test their design implementation to confirm system functionality.

8.1 Application Information

The ISO776x-Q1 family of devices is a high-performance, six-channel digital isolators. The ISO776x-Q1 family of devices uses single-ended CMOS-logic switching technology. The voltage range is from 2.25 V to 5.5 V for both supplies, V_{CC1} and V_{CC2} . When designing with digital isolators, keep in mind that because of the single-ended design structure, digital isolators do not conform to any specific interface standard and are only intended for isolating single-ended CMOS or TTL digital signal lines. The isolator is typically placed between the data controller (that is, μ C or UART), and a data converter or a line transceiver, regardless of the interface type or standard.

8.2 Typical Application

Figure 8-1 shows the isolated serial-peripheral interface (SPI) and controller-area network (CAN) interface implementation.

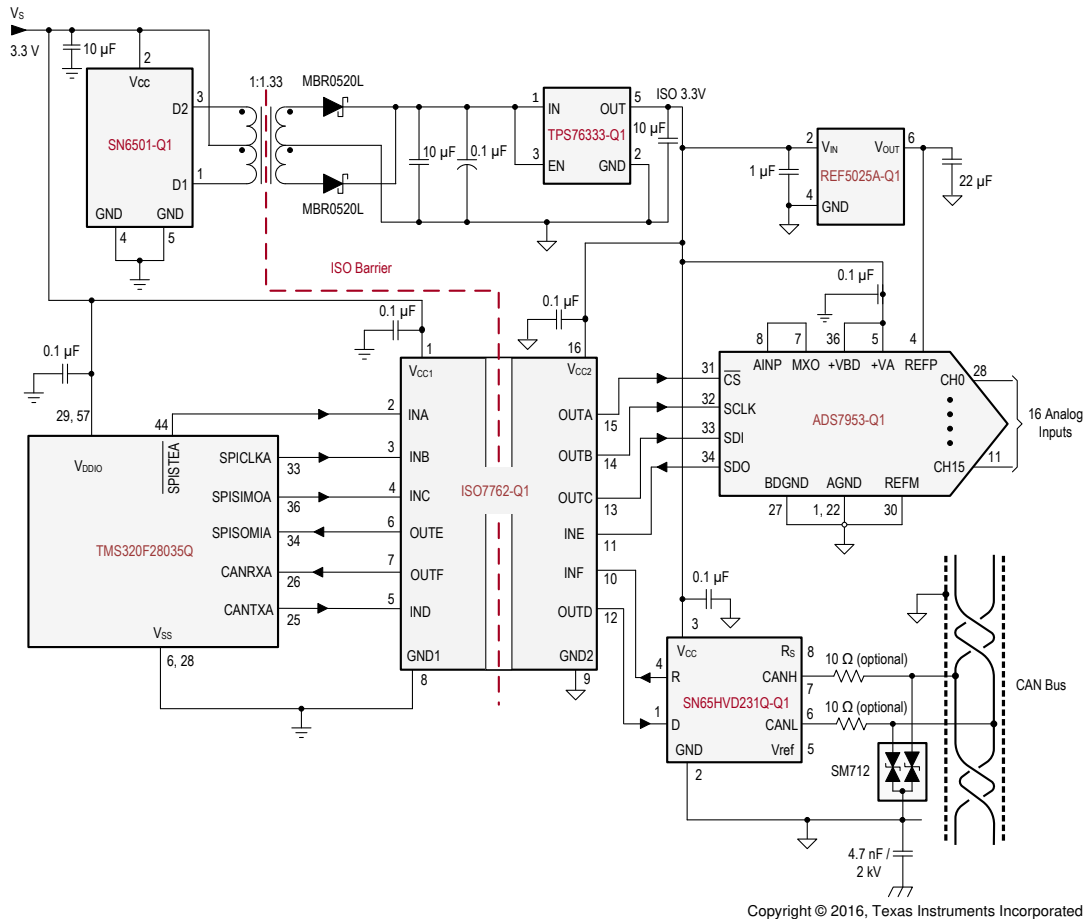

Multiple pins and discrete components omitted for clarity purpose.

Figure 8-1. Isolated SPI and CAN Interface

8.2.1 Design Requirements

For this design example, use the parameters listed in [Table 8-1](#).

Table 8-1. Design Parameters

PARAMETER	VALUE
Supply voltage, V_{CC1} and V_{CC2}	2.25 to 5.5 V
Decoupling capacitor between V_{CC1} and GND1	0.1 μ F
Decoupling capacitor from V_{CC2} and GND2	0.1 μ F

8.2.2 Detailed Design Procedure

Unlike optocouplers, which require external components to improve performance, provide bias, or limit current, the ISO776x-Q1 family of devices only requires two external bypass capacitors to operate.

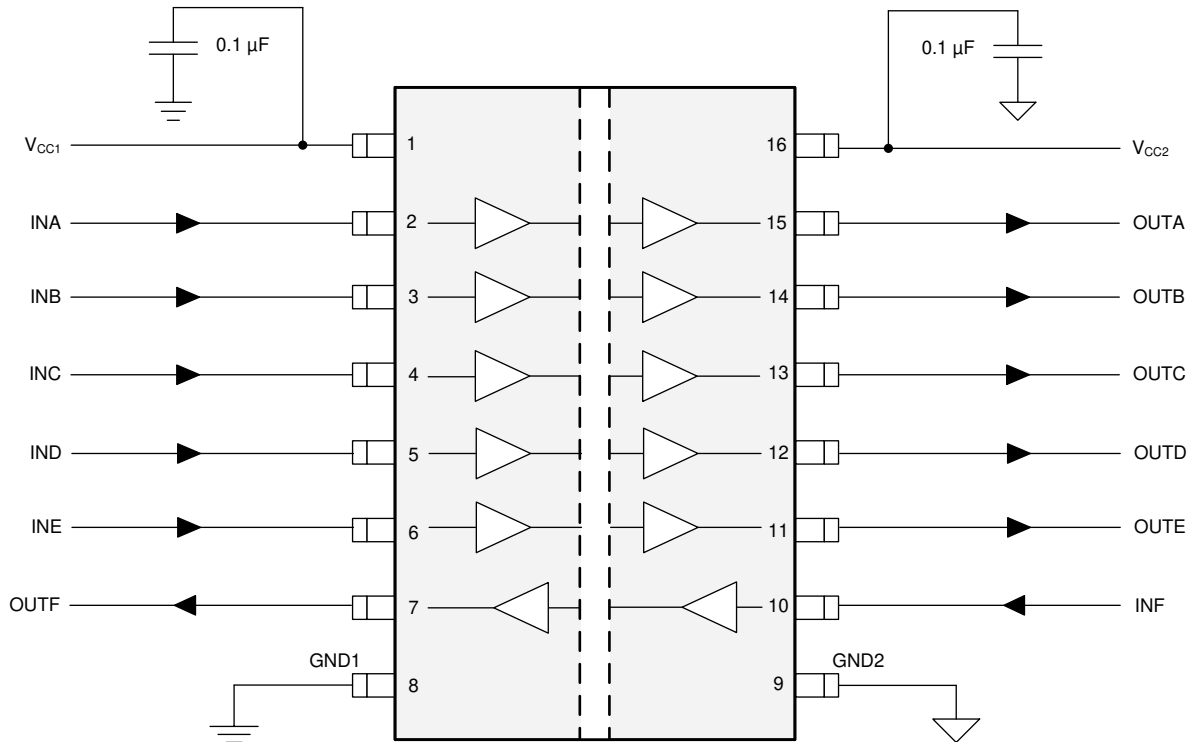

Figure 8-2. Typical ISO7761-Q1 Circuit Hook-up

8.2.3 Application Curves

The typical eye diagram of the ISO776x-Q1 family of devices indicates low jitter and a wide open eye at the maximum data rate of 100 Mbps.

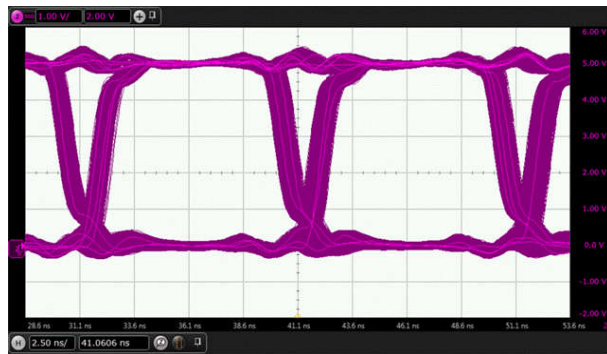

Figure 8-3. Eye Diagram at 100 Mbps PRBS $2^{16} - 1$ Data, 5 V and 25°C

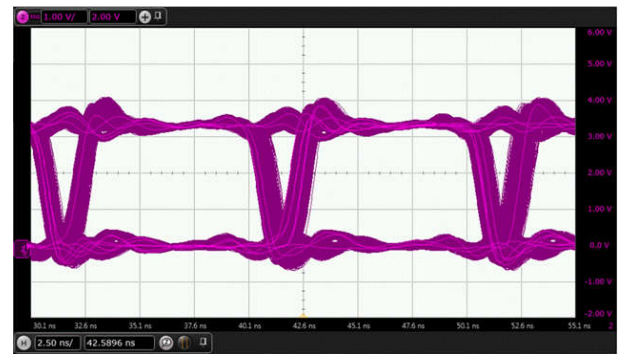

Figure 8-4. Eye Diagram at 100 Mbps PRBS $2^{16} - 1$ Data, 3.3 V and 25°C

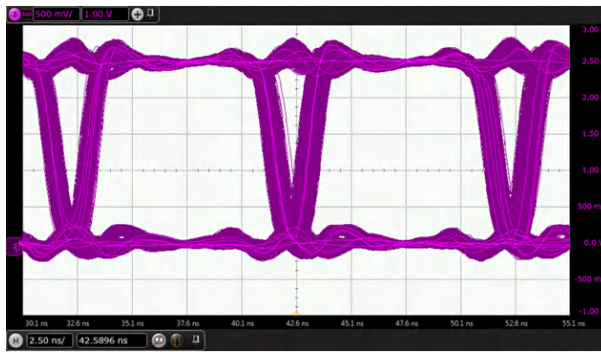

Figure 8-5. Eye Diagram at 100 Mbps PRBS $2^{16} - 1$ Data, 2.5 V and 25°C

8.2.3.1 Insulation Lifetime

Insulation lifetime projection data is collected by using industry-standard Time Dependent Dielectric Breakdown (TDDB) test method. In this test, all pins on each side of the barrier are tied together creating a two-terminal device and high voltage applied between the two sides; See [Figure 8-6](#) for TDDB test setup. The insulation breakdown data is collected at various high voltages switching at 60 Hz over temperature. For reinforced insulation, VDE standard requires the use of TDDB projection line with failure rate of less than 1 part per million (ppm). Even though the expected minimum insulation lifetime is 20 years at the specified working isolation voltage, VDE reinforced certification requires additional safety margin of 20% for working voltage and 50% for lifetime which translates into minimum required insulation lifetime of 30 years at a working voltage that's 20% higher than the specified value.

[Figure 8-7](#) shows the intrinsic capability of the isolation barrier to withstand high voltage stress over its lifetime. Based on the TDDB data, the intrinsic capability of the insulation is 1500 V_{RMS} with a lifetime of 36 years. Other factors, such as package size, pollution degree, material group, etc. can further limit the working voltage of the component. The working voltage of DW-16 package is specified upto 1500 V_{RMS} and DBQ-16 package up to 400 V_{RMS}. At the lower working voltages, the corresponding insulation lifetime is much longer than 36 years.

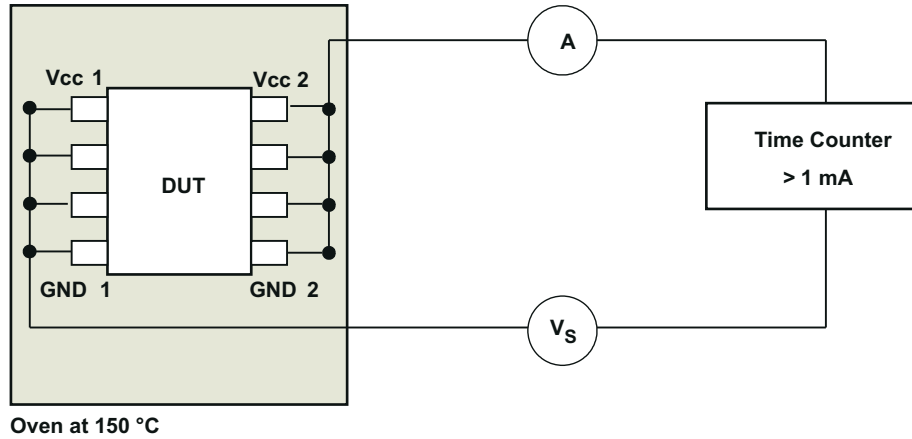

Figure 8-6. Test Setup for Insulation Lifetime Measurement

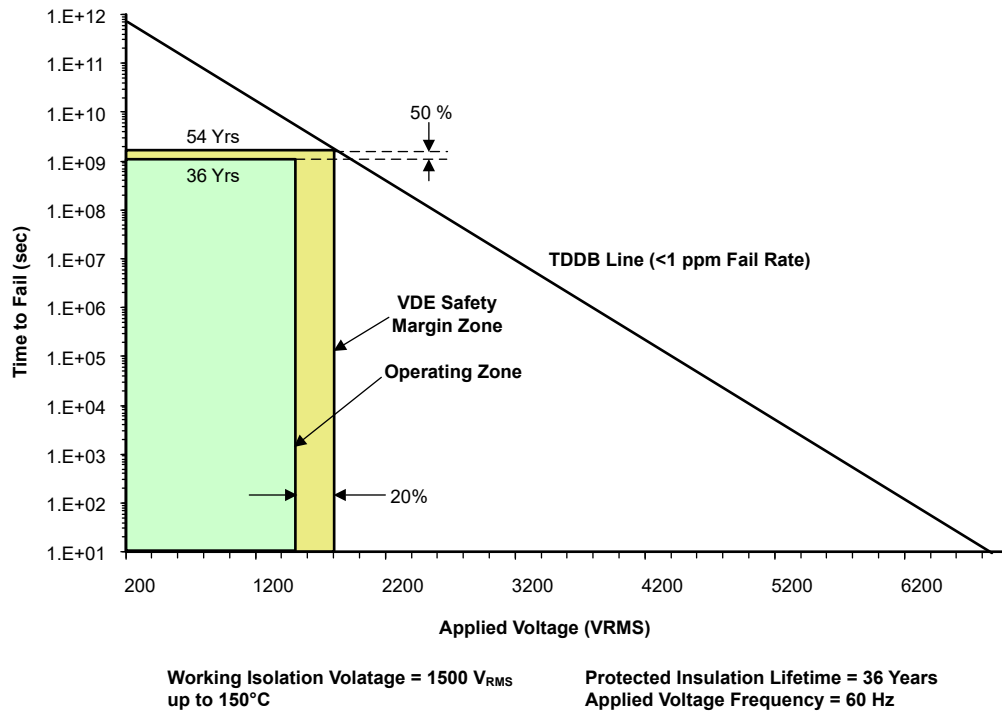

Figure 8-7. Insulation Lifetime Projection Data

9 Power Supply Recommendations

To help ensure reliable operation at data rates and supply voltages, a 0.1- μF bypass capacitor is recommended at input and output supply pins (V_{CC1} and V_{CC2}). The capacitors should be placed as close to the supply pins as possible. If only a single primary-side power supply is available in an application, isolated power can be generated for the secondary-side with the help of a transformer driver such as Texas Instruments' [SN6501](#) or [SN6505](#). For such applications, detailed power supply design and transformer selection recommendations are available in the [SN6501 Transformer Driver for Isolated Power Supplies data sheet](#) or the [SN6505 Low-Noise 1-A Transformer Drivers for Isolated Power Supplies data sheet](#).

10 Layout

10.1 Layout Guidelines

A minimum of four layers is required to accomplish a low EMI PCB design (see [Figure 10-1](#)). Layer stacking should be in the following order (top-to-bottom): high-speed signal layer, ground plane, power plane and low-frequency signal layer.

- Routing the high-speed traces on the top layer avoids the use of vias (and the introduction of their inductances) and allows for clean interconnects between the isolator and the transmitter and receiver circuits of the data link.
- Placing a solid ground plane next to the high-speed signal layer establishes controlled impedance for transmission line interconnects and provides an excellent low-inductance path for the return current flow.
- Placing the power plane next to the ground plane creates additional high-frequency bypass capacitance of approximately 100 pF/inch².
- Routing the slower speed control signals on the bottom layer allows for greater flexibility as these signal links usually have margin to tolerate discontinuities such as vias.

If an additional supply voltage plane or signal layer is needed, add a second power or ground plane system to the stack to keep it symmetrical. This makes the stack mechanically stable and prevents it from warping. Also the power and ground plane of each power system can be placed closer together, thus increasing the high-frequency bypass capacitance significantly.

For detailed layout recommendations, see the [Digital Isolator Design Guide application report](#).

10.1.1 PCB Material

For digital circuit boards operating at less than 150 Mbps, (or rise and fall times greater than 1 ns), and trace lengths of up to 10 inches, use standard FR-4 UL94V-0 printed circuit board. This PCB is preferred over cheaper alternatives because of lower dielectric losses at high frequencies, less moisture absorption, greater strength and stiffness, and the self-extinguishing flammability-characteristics.

10.2 Layout Example

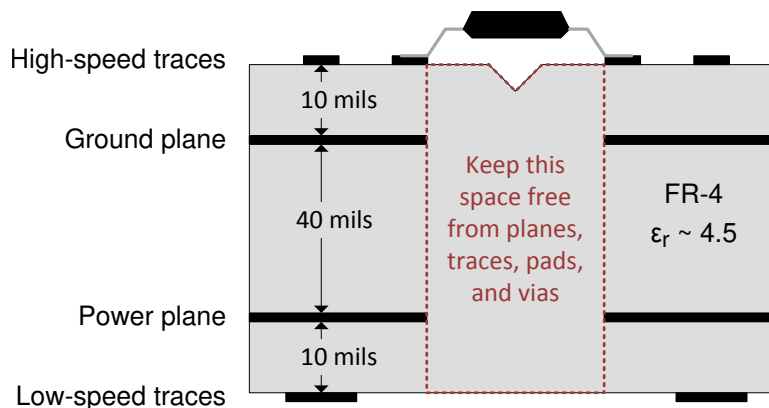

Figure 10-1. Layout Example Schematic

11 Device and Documentation Support

11.1 Documentation Support

11.1.1 Related Documentation

For related documentation see the following:

- Texas Instruments, [Digital Isolator Design Guide application report](#)
- Texas Instruments, [How to use isolation to improve ESD, EFT and Surge immunity in industrial systems application report](#)
- Texas Instruments, [Isolation Glossary](#)
- Texas Instruments, [TMS320F2803xPiccolo™ Microcontrollers data sheet](#)
- Texas Instruments, [ADS7953-Q1 Automotive 12-Bit, 1MSPS, 16-Channel Single-Ended Micropower, Serial Interface ADC data sheet](#)
- Texas Instruments, [REF50xxA-Q1 Low-Noise, Very Low Drift, Precision Voltage Reference data sheet](#)
- Texas Instruments, [SN6501-Q1 Transformer Driver for Isolated Power Supplies data sheet](#)
- Texas Instruments, [SN65HVD231Q-Q1 3.3-V CAN Transceiver data sheet](#)
- Texas Instruments, [TPS76333-Q1 Low-Power 150-mA Low-Dropout Linear Regulators data sheet](#)

11.2 Related Links

The table below lists quick access links. Categories include technical documents, support and community resources, tools and software, and quick access to sample or buy.

Table 11-1. Related Links

PARTS	PRODUCT FOLDER	SAMPLE & BUY	TECHNICAL DOCUMENTS	TOOLS & SOFTWARE	SUPPORT & COMMUNITY
ISO7760-Q1	Click here	Click here	Click here	Click here	Click here
ISO7761-Q1	Click here	Click here	Click here	Click here	Click here
ISO7762-Q1	Click here	Click here	Click here	Click here	Click here
ISO7763-Q1	Click here	Click here	Click here	Click here	Click here

11.3 Receiving Notification of Documentation Updates

To receive notification of documentation updates, navigate to the device product folder on ti.com. In the upper right corner, click on *Alert me* to register and receive a weekly digest of any product information that has changed. For change details, review the revision history included in any revised document.

11.4 Support Resources

[TI E2E™ support forums](#) are an engineer's go-to source for fast, verified answers and design help — straight from the experts. Search existing answers or ask your own question to get the quick design help you need.

Linked content is provided "AS IS" by the respective contributors. They do not constitute TI specifications and do not necessarily reflect TI's views; see TI's [Terms of Use](#).

11.5 Trademarks

Piccolo™ is a trademark of Texas Instruments.

TI E2E™ is a trademark of Texas Instruments.

All trademarks are the property of their respective owners.

11.6 Electrostatic Discharge Caution



This integrated circuit can be damaged by ESD. Texas Instruments recommends that all integrated circuits be handled with appropriate precautions. Failure to observe proper handling and installation procedures can cause damage.

ESD damage can range from subtle performance degradation to complete device failure. Precision integrated circuits may be more susceptible to damage because very small parametric changes could cause the device not to meet its published specifications.

11.7 Glossary

[TI Glossary](#) This glossary lists and explains terms, acronyms, and definitions.

12 Revision History

NOTE: Page numbers for previous revisions may differ from page numbers in the current version.

Changes from Revision C (October 2022) to Revision D (January 2024) Page

• Added table note to Data rate specification.....	7
• Changed V_{IORM} value for DW-16 package from "1414 V_{PK} " to "2121 V_{PK} "	9
• Changed V_{IOWM} values for DW-16 package from "1000 V_{RMS} " and "1414 V_{DC} " to "1500 V_{RMS} " and "2121 V_{DC} "	9
• Updated certification information.....	11

Changes from Revision B (October 2020) to Revision C (October 2022) Page

• Updated the numbering format for tables, figures, and cross-references throughout the document.....	1
• Changed standard name from: "DIN V VDE V 0884-11:2017-01" To: "DIN EN IEC 60747-17 (VDE 0884-17)" throughout the document.....	1
• Removed references to standard IEC/EN/CSA 60950-1 throughout the document.....	1
• Updated Thermal characteristics, Safety Limiting Values, and Thermal derating Curves to provide more accurate system-level thermal calculations.....	6
• Updated electrical and switching characteristics to match device performance.....	6
• Changed the C_{IO} value for the DBQ package from 1.1 to 0.9 pF.....	9
• Changed working voltage lifetime margin From: 87.5% To: 50%, minimum required insulation lifetime From: 37.5 years To: 30 years and insulation lifetime per TDDb From: 135 years To: 169 years in Insulation Lifetime per DIN EN IEC 60747-17 (VDE 0884-17).....	32
• Changed Figure 9-7 per DIN EN IEC 60747-17 (VDE 0884-17).....	32

Changes from Revision A (February 2019) to Revision B (October 2020) Page

• Added Functional Safety Bullets.....	1
• Added the maximum transient isolation voltage for the DW-16 package of the ISO7761, ISO7762, and ISO7763 devices and changed the maximum value for the DBQ-16 package from 3600 to 4242 for all devices.....	9
• Changed table note and table condition of safety limiting values.....	11

Changes from Revision * (November 2018) to Revision A (February 2019) Page

13 Mechanical, Packaging, and Orderable Information

The following pages include mechanical, packaging, and orderable information. This information is the most current data available for the designated devices. This data is subject to change without notice and revision of this document. For browser-based versions of this data sheet, refer to the left-hand navigation.

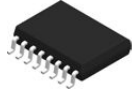

DW0016B

PACKAGE OUTLINE
SOIC - 2.65 mm max height

SOIC

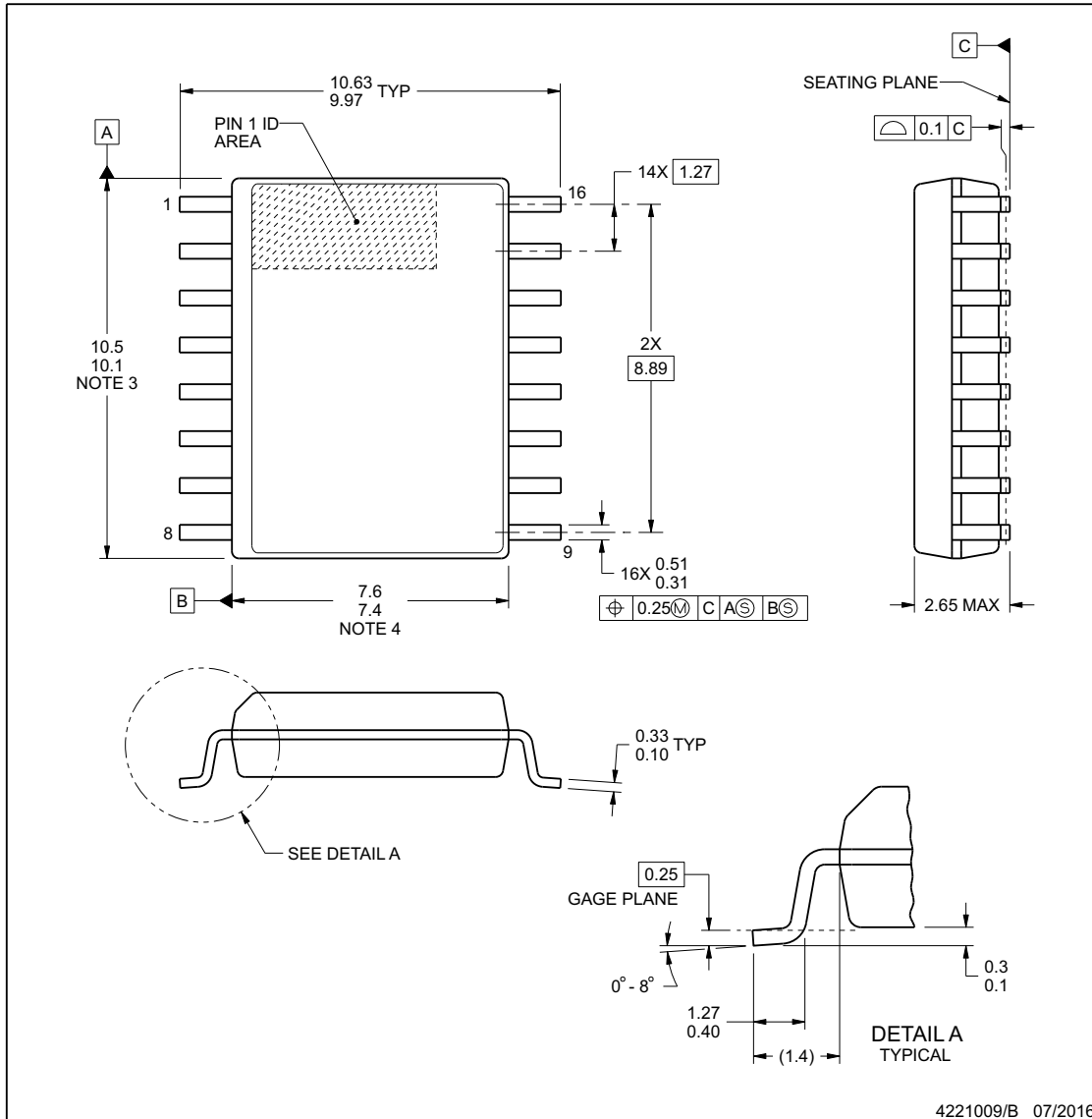

NOTES:

1. All linear dimensions are in millimeters. Dimensions in parenthesis are for reference only. Dimensioning and tolerancing per ASME Y14.5M.
2. This drawing is subject to change without notice.
3. This dimension does not include mold flash, protrusions, or gate burrs. Mold flash, protrusions, or gate burrs shall not exceed 0.15 mm, per side.
4. This dimension does not include interlead flash. Interlead flash shall not exceed 0.25 mm, per side.
5. Reference JEDEC registration MS-013.

www.ti.com

EXAMPLE BOARD LAYOUT

DW0016B

SOIC - 2.65 mm max height

SOIC

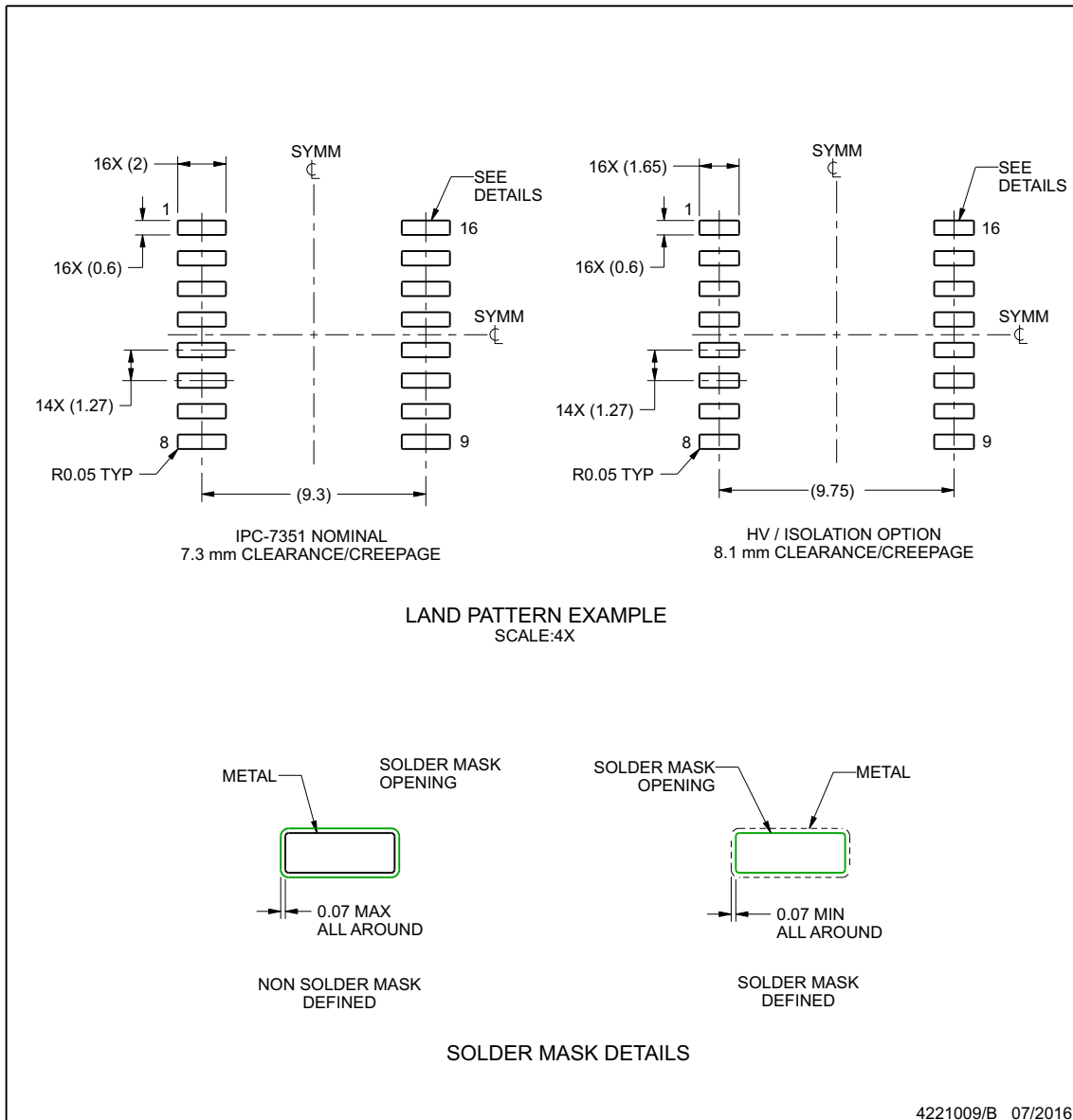

NOTES: (continued)

6. Publication IPC-7351 may have alternate designs.
7. Solder mask tolerances between and around signal pads can vary based on board fabrication site.

www.ti.com

EXAMPLE STENCIL DESIGN

DW0016B

SOIC - 2.65 mm max height

SOIC

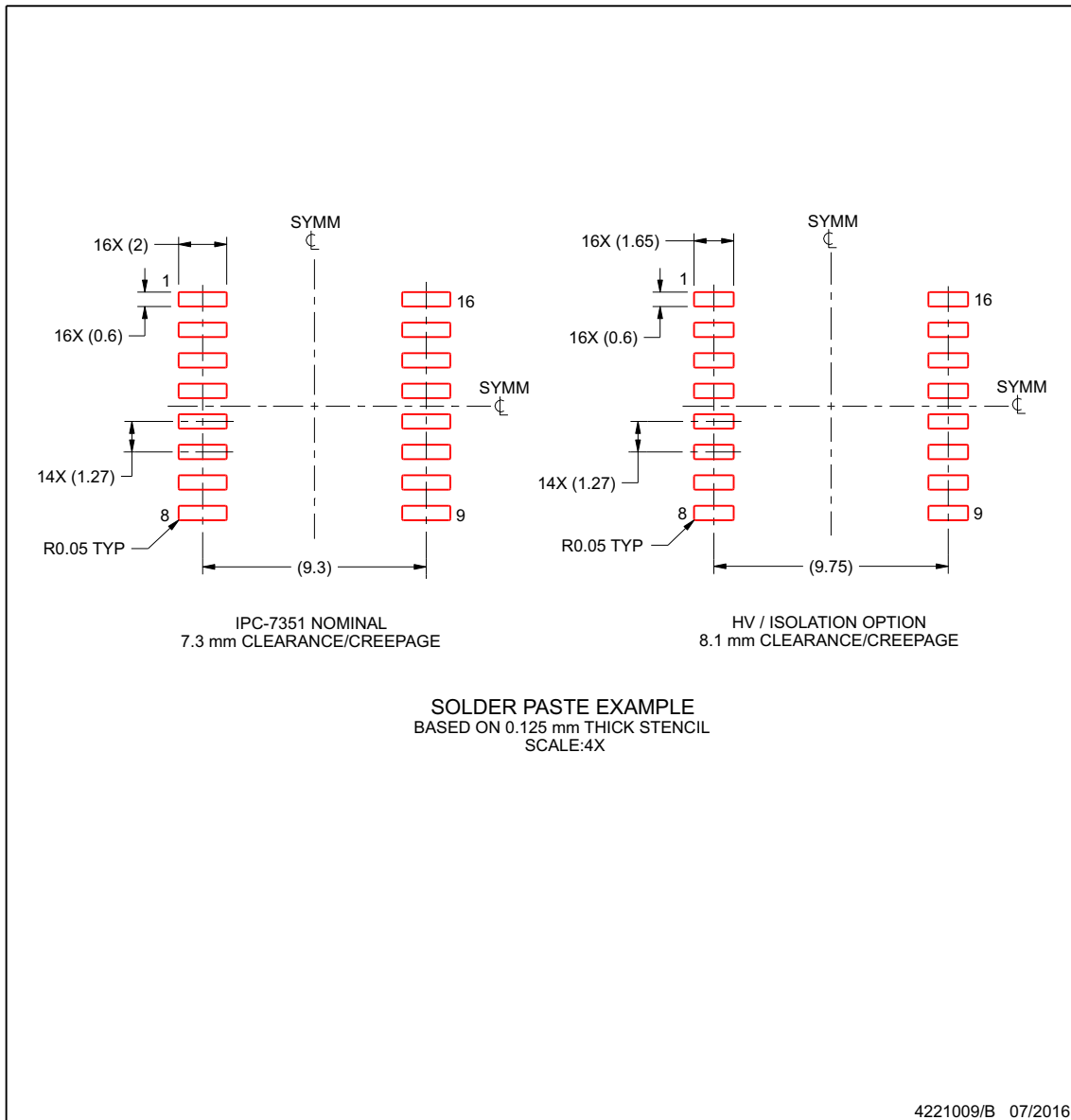

NOTES: (continued)

8. Laser cutting apertures with trapezoidal walls and rounded corners may offer better paste release. IPC-7525 may have alternate design recommendations.
9. Board assembly site may have different recommendations for stencil design.

www.ti.com

PACKAGING INFORMATION

Orderable Device	Status (1)	Package Type	Package Drawing	Pins	Package Qty	Eco Plan (2)	Lead finish/ Ball material (6)	MSL Peak Temp (3)	Op Temp (°C)	Device Marking (4/5)	Samples
ISO7760FQDBQQ1	ACTIVE	SSOP	DBQ	16	75	RoHS & Green	NIPDAU	Level-2-260C-1 YEAR	-40 to 125	7760FQ	Samples
ISO7760FQDBQRQ1	ACTIVE	SSOP	DBQ	16	2500	RoHS & Green	NIPDAU	Level-2-260C-1 YEAR	-40 to 125	7760FQ	Samples
ISO7760FQDWQ1	ACTIVE	SOIC	DW	16	40	RoHS & Green	NIPDAU	Level-2-260C-1 YEAR	-40 to 125	ISO7760FQ	Samples
ISO7760FQDWRQ1	ACTIVE	SOIC	DW	16	2000	RoHS & Green	NIPDAU	Level-2-260C-1 YEAR	-40 to 125	(ISO7760F, ISO7760FQ)	Samples
ISO7760QDBQQ1	ACTIVE	SSOP	DBQ	16	75	RoHS & Green	NIPDAU	Level-2-260C-1 YEAR	-40 to 125	7760Q	Samples
ISO7760QDBQRQ1	ACTIVE	SSOP	DBQ	16	2500	RoHS & Green	NIPDAU	Level-2-260C-1 YEAR	-40 to 125	7760Q	Samples
ISO7760QDWQ1	ACTIVE	SOIC	DW	16	40	RoHS & Green	NIPDAU	Level-2-260C-1 YEAR	-40 to 125	ISO7760Q	Samples
ISO7760QDWRQ1	ACTIVE	SOIC	DW	16	2000	RoHS & Green	NIPDAU	Level-2-260C-1 YEAR	-40 to 125	(ISO7760, ISO7760Q)	Samples
ISO7761FQDBQQ1	ACTIVE	SSOP	DBQ	16	75	RoHS & Green	NIPDAU	Level-2-260C-1 YEAR	-40 to 125	7761FQ	Samples
ISO7761FQDBQRQ1	ACTIVE	SSOP	DBQ	16	2500	RoHS & Green	NIPDAU	Level-2-260C-1 YEAR	-40 to 125	7761FQ	Samples
ISO7761FQDWQ1	ACTIVE	SOIC	DW	16	40	RoHS & Green	NIPDAU	Level-2-260C-1 YEAR	-40 to 125	ISO7761FQ	Samples
ISO7761FQDWRQ1	ACTIVE	SOIC	DW	16	2000	RoHS & Green	NIPDAU	Level-2-260C-1 YEAR	-40 to 125	(ISO7761F, ISO7761FQ)	Samples
ISO7761QDBQQ1	ACTIVE	SSOP	DBQ	16	75	RoHS & Green	NIPDAU	Level-2-260C-1 YEAR	-40 to 125	7761Q	Samples
ISO7761QDBQRQ1	ACTIVE	SSOP	DBQ	16	2500	RoHS & Green	NIPDAU	Level-2-260C-1 YEAR	-40 to 125	7761Q	Samples
ISO7761QDWQ1	ACTIVE	SOIC	DW	16	40	RoHS & Green	NIPDAU	Level-2-260C-1 YEAR	-40 to 125	ISO7761Q	Samples
ISO7761QDWRQ1	ACTIVE	SOIC	DW	16	2000	RoHS & Green	NIPDAU	Level-2-260C-1 YEAR	-40 to 125	(ISO7761, ISO7761Q)	Samples
ISO7762FQDBQQ1	ACTIVE	SSOP	DBQ	16	75	RoHS & Green	NIPDAU	Level-2-260C-1 YEAR	-40 to 125	7762FQ	Samples
ISO7762FQDBQRQ1	ACTIVE	SSOP	DBQ	16	2500	RoHS & Green	NIPDAU	Level-2-260C-1 YEAR	-40 to 125	7762FQ	Samples
ISO7762FQDWQ1	ACTIVE	SOIC	DW	16	40	RoHS & Green	NIPDAU	Level-2-260C-1 YEAR	-40 to 125	ISO7762FQ	Samples

Orderable Device	Status (1)	Package Type	Package Drawing	Pins	Package Qty	Eco Plan (2)	Lead finish/ Ball material (6)	MSL Peak Temp (3)	Op Temp (°C)	Device Marking (4/5)	Samples
ISO7762FQDWRQ1	ACTIVE	SOIC	DW	16	2000	RoHS & Green	NIPDAU	Level-2-260C-1 YEAR	-40 to 125	(ISO7762F, ISO7762 FQ)	Samples
ISO7762QDBQQ1	ACTIVE	SSOP	DBQ	16	75	RoHS & Green	NIPDAU	Level-2-260C-1 YEAR	-40 to 125	7762Q	Samples
ISO7762QDBQRQ1	ACTIVE	SSOP	DBQ	16	2500	RoHS & Green	NIPDAU	Level-2-260C-1 YEAR	-40 to 125	7762Q	Samples
ISO7762QDWQ1	ACTIVE	SOIC	DW	16	40	RoHS & Green	NIPDAU	Level-2-260C-1 YEAR	-40 to 125	ISO7762Q	Samples
ISO7762QDWRQ1	ACTIVE	SOIC	DW	16	2000	RoHS & Green	NIPDAU	Level-2-260C-1 YEAR	-40 to 125	(ISO7762, ISO7762Q)	Samples
ISO7763FQDBQQ1	ACTIVE	SSOP	DBQ	16	75	RoHS & Green	NIPDAU	Level-2-260C-1 YEAR	-40 to 125	7763FQ	Samples
ISO7763FQDBQRQ1	ACTIVE	SSOP	DBQ	16	2500	RoHS & Green	NIPDAU	Level-2-260C-1 YEAR	-40 to 125	7763FQ	Samples
ISO7763FQDWQ1	ACTIVE	SOIC	DW	16	40	RoHS & Green	NIPDAU	Level-2-260C-1 YEAR	-40 to 125	ISO7763FQ	Samples
ISO7763FQDWRQ1	ACTIVE	SOIC	DW	16	2000	RoHS & Green	NIPDAU	Level-2-260C-1 YEAR	-40 to 125	(ISO7763F, ISO7763 FQ)	Samples
ISO7763QDBQQ1	ACTIVE	SSOP	DBQ	16	75	RoHS & Green	NIPDAU	Level-2-260C-1 YEAR	-40 to 125	7763Q	Samples
ISO7763QDBQRQ1	ACTIVE	SSOP	DBQ	16	2500	RoHS & Green	NIPDAU	Level-2-260C-1 YEAR	-40 to 125	7763Q	Samples
ISO7763QDWQ1	ACTIVE	SOIC	DW	16	40	RoHS & Green	NIPDAU	Level-2-260C-1 YEAR	-40 to 125	ISO7763Q	Samples
ISO7763QDWRQ1	ACTIVE	SOIC	DW	16	2000	RoHS & Green	Call TI NIPDAU	Level-2-260C-1 YEAR	-40 to 125	(ISO7763, ISO7763Q)	Samples

(1) The marketing status values are defined as follows:

ACTIVE: Product device recommended for new designs.

LIFEBUY: TI has announced that the device will be discontinued, and a lifetime-buy period is in effect.

NRND: Not recommended for new designs. Device is in production to support existing customers, but TI does not recommend using this part in a new design.

PREVIEW: Device has been announced but is not in production. Samples may or may not be available.

OBSELETE: TI has discontinued the production of the device.

(2) **RoHS:** TI defines "RoHS" to mean semiconductor products that are compliant with the current EU RoHS requirements for all 10 RoHS substances, including the requirement that RoHS substance do not exceed 0.1% by weight in homogeneous materials. Where designed to be soldered at high temperatures, "RoHS" products are suitable for use in specified lead-free processes. TI may reference these types of products as "Pb-Free".

RoHS Exempt: TI defines "RoHS Exempt" to mean products that contain lead but are compliant with EU RoHS pursuant to a specific EU RoHS exemption.

Green: TI defines "Green" to mean the content of Chlorine (Cl) and Bromine (Br) based flame retardants meet JS709B low halogen requirements of <=1000ppm threshold. Antimony trioxide based flame retardants must also meet the <=1000ppm threshold requirement.

(3) MSL, Peak Temp. - The Moisture Sensitivity Level rating according to the JEDEC industry standard classifications, and peak solder temperature.

(4) There may be additional marking, which relates to the logo, the lot trace code information, or the environmental category on the device.

(5) Multiple Device Markings will be inside parentheses. Only one Device Marking contained in parentheses and separated by a "~" will appear on a device. If a line is indented then it is a continuation of the previous line and the two combined represent the entire Device Marking for that device.

(6) Lead finish/Ball material - Orderable Devices may have multiple material finish options. Finish options are separated by a vertical ruled line. Lead finish/Ball material values may wrap to two lines if the finish value exceeds the maximum column width.

Important Information and Disclaimer:The information provided on this page represents TI's knowledge and belief as of the date that it is provided. TI bases its knowledge and belief on information provided by third parties, and makes no representation or warranty as to the accuracy of such information. Efforts are underway to better integrate information from third parties. TI has taken and continues to take reasonable steps to provide representative and accurate information but may not have conducted destructive testing or chemical analysis on incoming materials and chemicals. TI and TI suppliers consider certain information to be proprietary, and thus CAS numbers and other limited information may not be available for release.

In no event shall TI's liability arising out of such information exceed the total purchase price of the TI part(s) at issue in this document sold by TI to Customer on an annual basis.

OTHER QUALIFIED VERSIONS OF ISO7760-Q1, ISO7761-Q1, ISO7762-Q1, ISO7763-Q1 :

- Catalog : [ISO7760](#), [ISO7761](#), [ISO7762](#), [ISO7763](#)

NOTE: Qualified Version Definitions:

- Catalog - TI's standard catalog product

TAPE AND REEL INFORMATION



QUADRANT ASSIGNMENTS FOR PIN 1 ORIENTATION IN TAPE

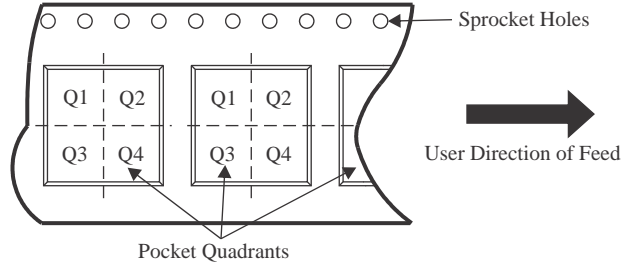

*All dimensions are nominal

Device	Package Type	Package Drawing	Pins	SPQ	Reel Diameter (mm)	Reel Width W1 (mm)	A0 (mm)	B0 (mm)	K0 (mm)	P1 (mm)	W (mm)	Pin1 Quadrant
ISO7760FQDBQRQ1	SSOP	DBQ	16	2500	330.0	12.4	6.4	5.2	2.1	8.0	12.0	Q1
ISO7760FQDWRQ1	SOIC	DW	16	2000	330.0	16.4	10.75	10.7	2.7	12.0	16.0	Q1
ISO7760QDBQRQ1	SSOP	DBQ	16	2500	330.0	12.4	6.4	5.2	2.1	8.0	12.0	Q1
ISO7760QDWRQ1	SOIC	DW	16	2000	330.0	16.4	10.75	10.7	2.7	12.0	16.0	Q1
ISO7761FQDBQRQ1	SSOP	DBQ	16	2500	330.0	12.4	6.4	5.2	2.1	8.0	12.0	Q1
ISO7761FQDWRQ1	SOIC	DW	16	2000	330.0	16.4	10.75	10.7	2.7	12.0	16.0	Q1
ISO7761QDBQRQ1	SSOP	DBQ	16	2500	330.0	12.4	6.4	5.2	2.1	8.0	12.0	Q1
ISO7761QDWRQ1	SOIC	DW	16	2000	330.0	16.4	10.75	10.7	2.7	12.0	16.0	Q1
ISO7762FQDBQRQ1	SSOP	DBQ	16	2500	330.0	12.4	6.4	5.2	2.1	8.0	12.0	Q1
ISO7762FQDWRQ1	SOIC	DW	16	2000	330.0	16.4	10.75	10.7	2.7	12.0	16.0	Q1
ISO7762QDBQRQ1	SSOP	DBQ	16	2500	330.0	12.4	6.4	5.2	2.1	8.0	12.0	Q1
ISO7762QDWRQ1	SOIC	DW	16	2000	330.0	16.4	10.75	10.7	2.7	12.0	16.0	Q1
ISO7763FQDBQRQ1	SSOP	DBQ	16	2500	330.0	12.4	6.4	5.2	2.1	8.0	12.0	Q1
ISO7763FQDWRQ1	SOIC	DW	16	2000	330.0	16.4	10.75	10.7	2.7	12.0	16.0	Q1
ISO7763QDBQRQ1	SSOP	DBQ	16	2500	330.0	12.4	6.4	5.2	2.1	8.0	12.0	Q1
ISO7763QDWRQ1	SOIC	DW	16	2000	330.0	16.4	10.75	10.7	2.7	12.0	16.0	Q1

TAPE AND REEL BOX DIMENSIONS

*All dimensions are nominal

Device	Package Type	Package Drawing	Pins	SPQ	Length (mm)	Width (mm)	Height (mm)
ISO7760FQDBQRQ1	SSOP	DBQ	16	2500	350.0	350.0	43.0
ISO7760FQDWRQ1	SOIC	DW	16	2000	350.0	350.0	43.0
ISO7760QDBQRQ1	SSOP	DBQ	16	2500	367.0	367.0	38.0
ISO7760QDWRQ1	SOIC	DW	16	2000	350.0	350.0	43.0
ISO7761FQDBQRQ1	SSOP	DBQ	16	2500	367.0	367.0	38.0
ISO7761FQDWRQ1	SOIC	DW	16	2000	350.0	350.0	43.0
ISO7761QDBQRQ1	SSOP	DBQ	16	2500	367.0	367.0	38.0
ISO7761QDWRQ1	SOIC	DW	16	2000	350.0	350.0	43.0
ISO7762FQDBQRQ1	SSOP	DBQ	16	2500	367.0	367.0	38.0
ISO7762FQDWRQ1	SOIC	DW	16	2000	350.0	350.0	43.0
ISO7762QDBQRQ1	SSOP	DBQ	16	2500	367.0	367.0	38.0
ISO7762QDWRQ1	SOIC	DW	16	2000	350.0	350.0	43.0
ISO7763FQDBQRQ1	SSOP	DBQ	16	2500	350.0	350.0	43.0
ISO7763FQDWRQ1	SOIC	DW	16	2000	350.0	350.0	43.0
ISO7763QDBQRQ1	SSOP	DBQ	16	2500	367.0	367.0	38.0
ISO7763QDWRQ1	SOIC	DW	16	2000	350.0	350.0	43.0

TUBE

*All dimensions are nominal

Device	Package Name	Package Type	Pins	SPQ	L (mm)	W (mm)	T (µm)	B (mm)
ISO7760FQDBQQ1	DBQ	SSOP	16	75	505.46	6.76	3810	4
ISO7760FQDWQ1	DW	SOIC	16	40	506.98	12.7	4826	6.6
ISO7760QDBQQ1	DBQ	SSOP	16	75	505.46	6.76	3810	4
ISO7760QDWQ1	DW	SOIC	16	40	506.98	12.7	4826	6.6
ISO7761FQDBQQ1	DBQ	SSOP	16	75	505.46	6.76	3810	4
ISO7761FQDWQ1	DW	SOIC	16	40	506.98	12.7	4826	6.6
ISO7761QDBQQ1	DBQ	SSOP	16	75	505.46	6.76	3810	4
ISO7761QDWQ1	DW	SOIC	16	40	506.98	12.7	4826	6.6
ISO7762FQDBQQ1	DBQ	SSOP	16	75	505.46	6.76	3810	4
ISO7762FQDWQ1	DW	SOIC	16	40	506.98	12.7	4826	6.6
ISO7762QDBQQ1	DBQ	SSOP	16	75	505.46	6.76	3810	4
ISO7762QDWQ1	DW	SOIC	16	40	506.98	12.7	4826	6.6
ISO7763FQDBQQ1	DBQ	SSOP	16	75	505.46	6.76	3810	4
ISO7763FQDWQ1	DW	SOIC	16	40	506.98	12.7	4826	6.6
ISO7763QDBQQ1	DBQ	SSOP	16	75	505.46	6.76	3810	4
ISO7763QDWQ1	DW	SOIC	16	40	506.98	12.7	4826	6.6

GENERIC PACKAGE VIEW

DW 16

SOIC - 2.65 mm max height

7.5 x 10.3, 1.27 mm pitch

SMALL OUTLINE INTEGRATED CIRCUIT

This image is a representation of the package family, actual package may vary.
Refer to the product data sheet for package details.



4224780/A



DW0016B

PACKAGE OUTLINE

SOIC - 2.65 mm max height

SOIC

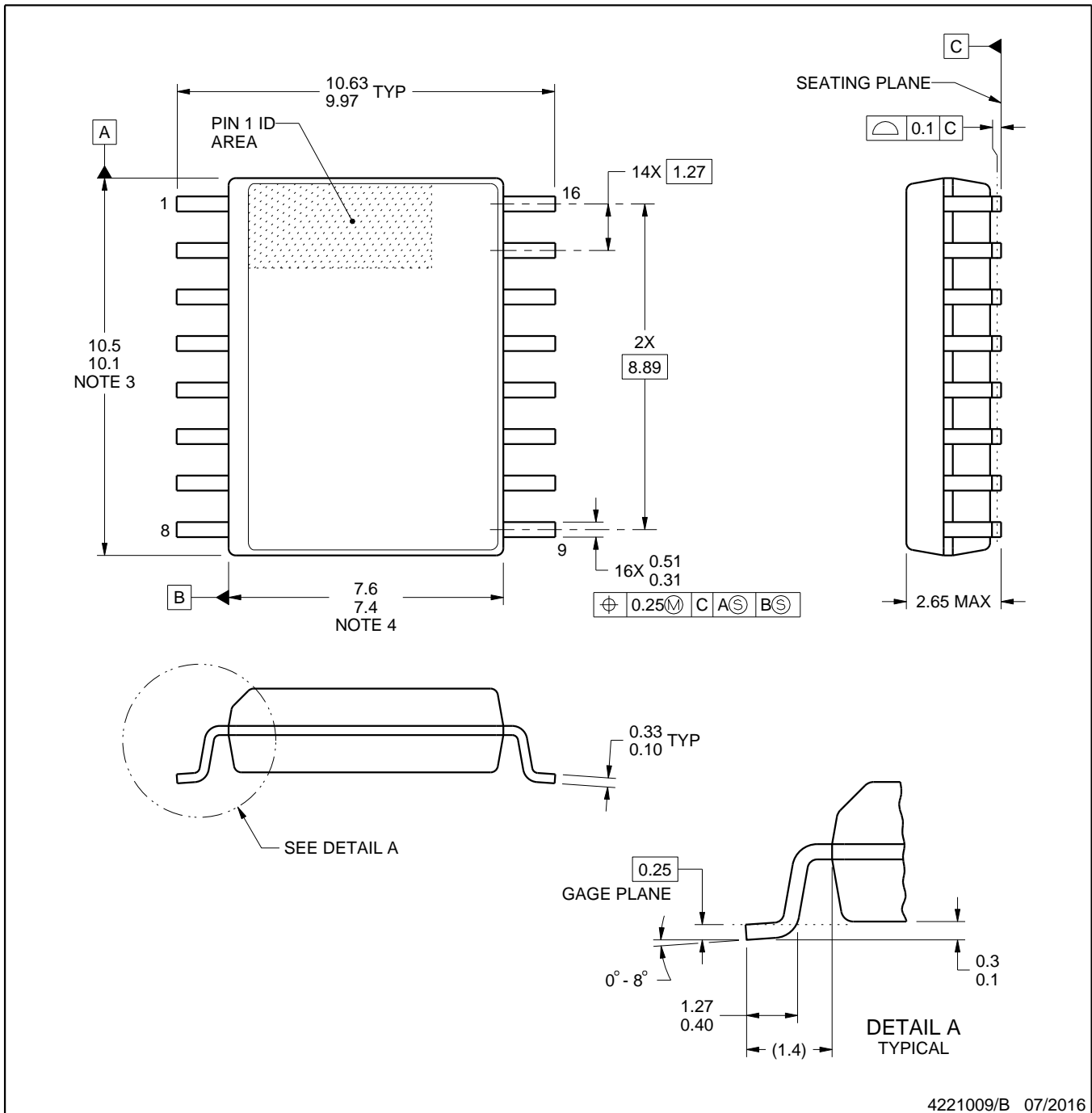

4221009/B 07/2016

NOTES:

1. All linear dimensions are in millimeters. Dimensions in parenthesis are for reference only. Dimensioning and tolerancing per ASME Y14.5M.
2. This drawing is subject to change without notice.
3. This dimension does not include mold flash, protrusions, or gate burrs. Mold flash, protrusions, or gate burrs shall not exceed 0.15 mm, per side.
4. This dimension does not include interlead flash. Interlead flash shall not exceed 0.25 mm, per side.
5. Reference JEDEC registration MS-013.

EXAMPLE BOARD LAYOUT

DW0016B

SOIC - 2.65 mm max height

SOIC



LAND PATTERN EXAMPLE
SCALE:4X



SOLDER MASK DETAILS

4221009/B 07/2016

NOTES: (continued)

- 6. Publication IPC-7351 may have alternate designs.
- 7. Solder mask tolerances between and around signal pads can vary based on board fabrication site.

EXAMPLE STENCIL DESIGN

DW0016B

SOIC - 2.65 mm max height

SOIC



NOTES: (continued)

- 8. Laser cutting apertures with trapezoidal walls and rounded corners may offer better paste release. IPC-7525 may have alternate design recommendations.
- 9. Board assembly site may have different recommendations for stencil design.

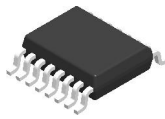

DBQ0016A

PACKAGE OUTLINE

SSOP - 1.75 mm max height

SHRINK SMALL-OUTLINE PACKAGE

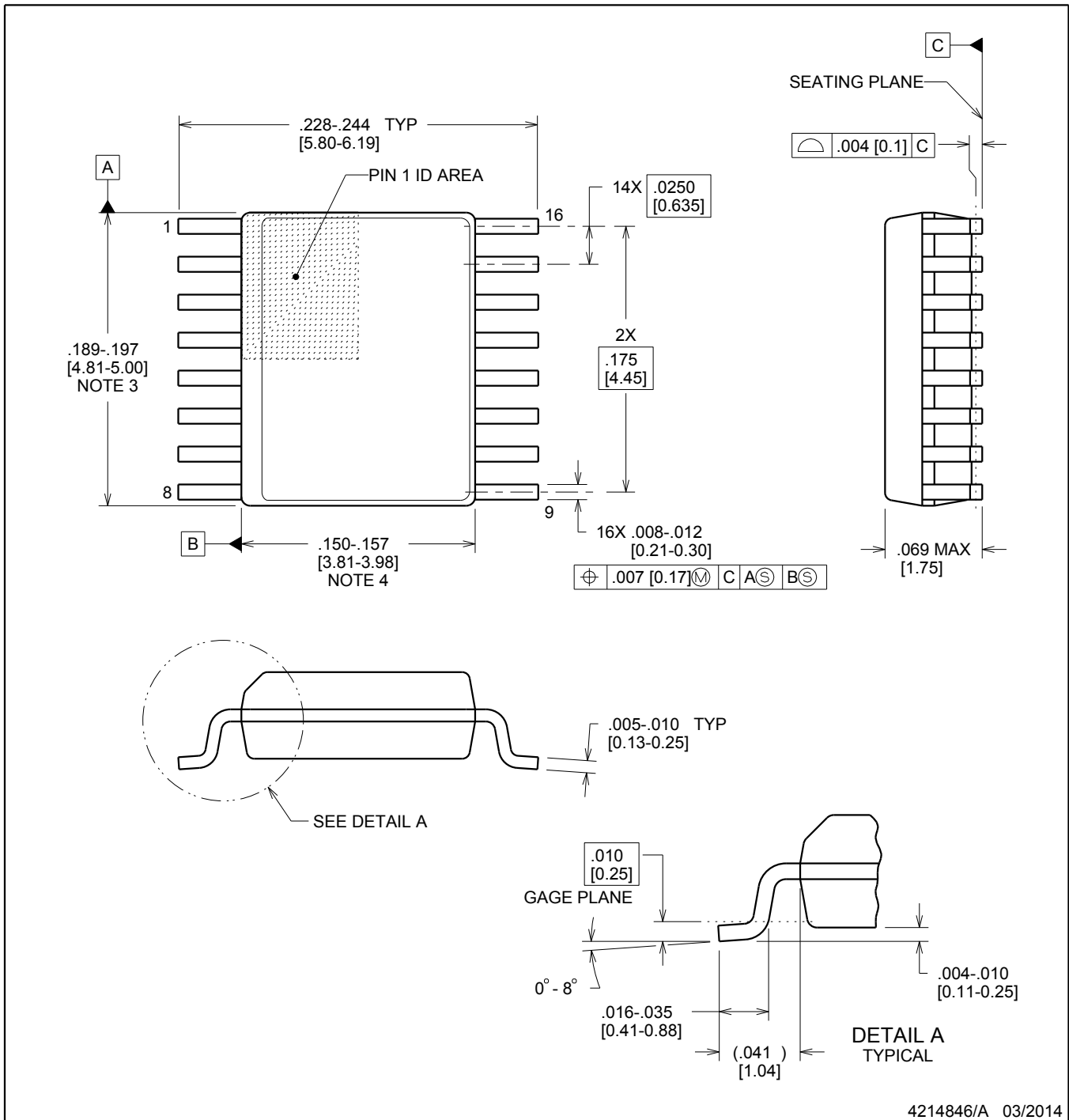

4214846/A 03/2014

NOTES:

1. Linear dimensions are in inches [millimeters]. Dimensions in parenthesis are for reference only. Controlling dimensions are in inches. Dimensioning and tolerancing per ASME Y14.5M.
2. This drawing is subject to change without notice.
3. This dimension does not include mold flash, protrusions, or gate burrs. Mold flash, protrusions, or gate burrs shall not exceed .006 inch, per side.
4. This dimension does not include interlead flash.
5. Reference JEDEC registration MO-137, variation AB.

EXAMPLE BOARD LAYOUT

DBQ0016A

SSOP - 1.75 mm max height

SHRINK SMALL-OUTLINE PACKAGE



LAND PATTERN EXAMPLE
SCALE:8X



SOLDER MASK DETAILS

4214846/A 03/2014

NOTES: (continued)

- 6. Publication IPC-7351 may have alternate designs.
- 7. Solder mask tolerances between and around signal pads can vary based on board fabrication site.

EXAMPLE STENCIL DESIGN

DBQ0016A

SSOP - 1.75 mm max height

SHRINK SMALL-OUTLINE PACKAGE



SOLDER PASTE EXAMPLE
BASED ON .005 INCH [0.127 MM] THICK STENCIL
SCALE:8X

4214846/A 03/2014

NOTES: (continued)

8. Laser cutting apertures with trapezoidal walls and rounded corners may offer better paste release. IPC-7525 may have alternate design recommendations.
9. Board assembly site may have different recommendations for stencil design.

IMPORTANT NOTICE AND DISCLAIMER

TI PROVIDES TECHNICAL AND RELIABILITY DATA (INCLUDING DATA SHEETS), DESIGN RESOURCES (INCLUDING REFERENCE DESIGNS), APPLICATION OR OTHER DESIGN ADVICE, WEB TOOLS, SAFETY INFORMATION, AND OTHER RESOURCES "AS IS" AND WITH ALL FAULTS, AND DISCLAIMS ALL WARRANTIES, EXPRESS AND IMPLIED, INCLUDING WITHOUT LIMITATION ANY IMPLIED WARRANTIES OF MERCHANTABILITY, FITNESS FOR A PARTICULAR PURPOSE OR NON-INFRINGEMENT OF THIRD PARTY INTELLECTUAL PROPERTY RIGHTS.

These resources are intended for skilled developers designing with TI products. You are solely responsible for (1) selecting the appropriate TI products for your application, (2) designing, validating and testing your application, and (3) ensuring your application meets applicable standards, and any other safety, security, regulatory or other requirements.

These resources are subject to change without notice. TI grants you permission to use these resources only for development of an application that uses the TI products described in the resource. Other reproduction and display of these resources is prohibited. No license is granted to any other TI intellectual property right or to any third party intellectual property right. TI disclaims responsibility for, and you will fully indemnify TI and its representatives against, any claims, damages, costs, losses, and liabilities arising out of your use of these resources.

TI's products are provided subject to [TI's Terms of Sale](#) or other applicable terms available either on [ti.com](https://www.ti.com) or provided in conjunction with such TI products. TI's provision of these resources does not expand or otherwise alter TI's applicable warranties or warranty disclaimers for TI products.

TI objects to and rejects any additional or different terms you may have proposed.

Mailing Address: Texas Instruments, Post Office Box 655303, Dallas, Texas 75265
Copyright © 2024, Texas Instruments Incorporated