

LM137, LM337-N 3-Terminal Adjustable Negative Regulators

1 Features

- 1.5A Output Current
- Line Regulation 0.01%/V (Typical)
- Load Regulation 0.3% (Typical)
- 77dB Ripple Rejection
- 50ppm/°C Temperature Coefficient
- Thermal Overload Protection
- Internal Short-Circuit Current Limiting Protections

2 Applications

- Industrial Power Supplies
- Factory Automation Systems
- Building Automation Systems
- PLC Systems
- Instrumentation
- IGBT Drive Negative Gate Supplies
- Networking
- Set-Top Boxes

3 Description

The LM137 and LM337-N are adjustable 3-terminal negative voltage regulators capable of supplying -1.5A or more currents over an output voltage range of -1.25V to -37V. It requires only two external resistors to set the output voltage and one output capacitor for frequency compensation. The circuit design has been optimized for excellent regulation and low thermal transients. Further, the LM137 and LM337-N feature internal current limiting, thermal shutdown and safe-area compensation, making it virtually blowout-proof against overloads.

The LM137 and LM337-N are ideal complements to the LM117 and LM317 adjustable positive regulators. The LM137 has a wider operating temperature range than the LM337-N and is also offered in military and space qualified versions.

Device Information (1)

PART NUMBER	PACKAGE	BODY SIZE (NOM)
LM137	TO (3)	8.255mm × 8.255mm
LM337-N	SOT-223 (4)	3.50mm × 6.50mm
	TO (3)	8.255mm × 8.255mm
	TO-220 (3)	10.16mm × 14.986mm

(1) For all available packages, see the orderable addendum at the end of the data sheet. The LF01 is a lead formed (bent) version of the TO-220 package.

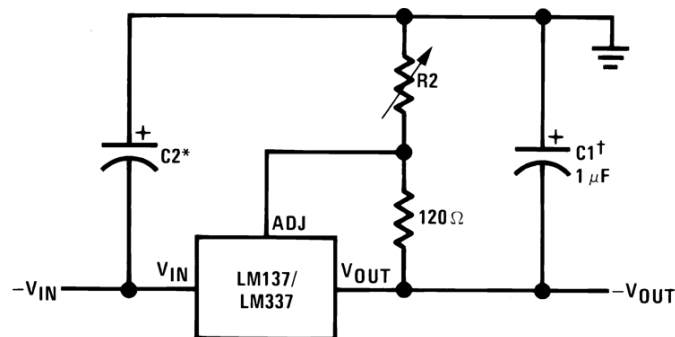

$$-V_{OUT} = -1.25V \left(1 + \frac{R2}{120} \right) + (-I_{ADJ} \times R2)$$

Full output current not available at high input-output voltages
 †C1 = 1µF solid tantalum or 10µF aluminum electrolytic required for stability *C2 = 1µF solid tantalum is required only if regulator is more than 4" from power-supply filter capacitor Output capacitors in the range of 1µF to 1000µF of aluminum or tantalum electrolytic are commonly used to provide improved output impedance and rejection of transients

Adjustable Negative Voltage Regulator



Table of Contents

1 Features	1	7.1 Application Information.....	11
2 Applications	1	7.2 Typical Applications.....	11
3 Description	1	8 Power Supply Recommendations	14
4 Pin Configuration and Functions	3	9 Layout	15
5 Specifications	4	9.1 Layout Guidelines.....	15
5.1 Absolute Maximum Ratings.....	4	9.2 Layout Example.....	15
5.2 ESD Ratings.....	4	9.3 Thermal Considerations.....	16
5.3 Recommended Operating Conditions.....	4	10 Device and Documentation Support	17
5.4 Thermal Information.....	4	10.1 Documentation Support.....	17
5.5 Electrical Characteristics.....	5	10.2 Receiving Notification of Documentation Updates..	17
5.6 Typical Characteristics.....	6	10.3 Support Resources.....	17
6 Detailed Description	8	10.4 Trademarks.....	17
6.1 Overview.....	8	10.5 Electrostatic Discharge Caution.....	17
6.2 Functional Block Diagram.....	8	10.6 Glossary.....	17
6.3 Feature Description.....	8	11 Revision History	17
6.4 Device Functional Modes.....	10	12 Mechanical, Packaging, and Orderable Information	18
7 Application and Implementation	11		

4 Pin Configuration and Functions

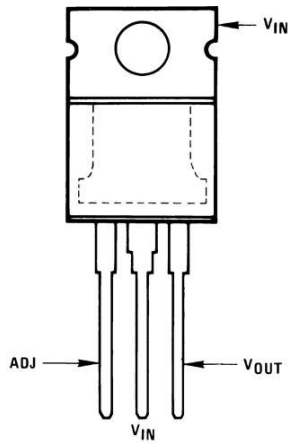

Figure 4-1. TO-220 Plastic Package Package Number NDE0003B Front View

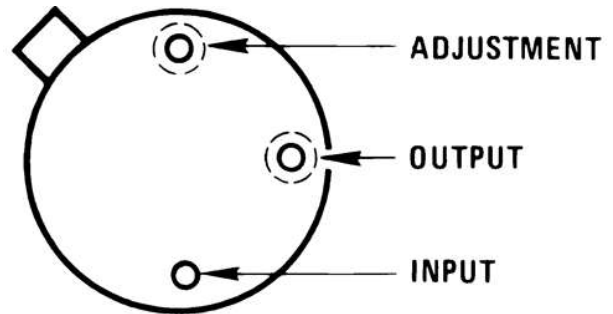

Figure 4-2. TO Metal Can Package 3-Pin Package Number NDT0003A Bottom View

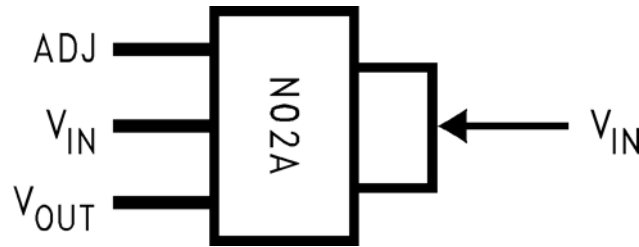

Figure 4-3. SOT-223 3-Lead Package Marked N02A Front View

Table 4-1. Pin Functions

NAME	PIN			I/O	DESCRIPTION
	TO-220	TO	SOT-223		
ADJ	1	1	1	—	Adjust pin
V _{IN}	2, TAB	3, CASE	2, 4	I	Input voltage pin for the regulator
V _{OUT}	3	2	3	O	Output voltage pin for the regulator

5 Specifications

5.1 Absolute Maximum Ratings

		MIN	MAX	UNIT
Power dissipation		Internally Limited		
Input-output voltage differential		-0.3	40	V
Operating junction temperature	LM137	-55	150	°C
	LM337-N	0	125	
	LM337I	-40	125	
Lead temperature (soldering, 10 s)			300	°C
Plastic package (soldering, 4 s)			260	°C
Storage temperature, T _{stg}		-65	150	°C

5.2 ESD Ratings

			VALUE	UNIT
V _(ESD)	Electrostatic discharge	Human-body model (HBM), per ANSI/ESDA/JEDEC JS-001 ⁽¹⁾	±2000	V

- (1) JEDEC document JEP155 states that 500-V HBM allows safe manufacturing with a standard ESD control process. Pins listed as ±2000 V may actually have higher performance.

5.3 Recommended Operating Conditions

over operating free-air temperature range (unless otherwise noted)

		MIN	MAX	UNIT
Operating junction temperature	LM137	-55	150	°C
	LM337-N	0	125	
	LM337I	-40	125	

5.4 Thermal Information

THERMAL METRIC ⁽¹⁾	LM137	LM337-N			UNIT
	NDT (TO)	NDT (TO)	DCY (SOT-223)	NDE OR NDG (TO-220)	
	3 PINS	3 PINS	3 PINS	3 PINS	
R _{θJA} Junction-to-ambient thermal resistance	140 ⁽²⁾	140 ⁽²⁾	58.3	22.9	°C/W
R _{θJC(top)} Junction-to-case (top) thermal resistance	12	12	36.6	15.7	°C/W
R _{θJB} Junction-to-board thermal resistance	—	—	7.2	4.1	°C/W
ψ _{JT} Junction-to-top characterization parameter	—	—	1.3	2.4	°C/W
ψ _{JB} Junction-to-board characterization parameter	—	—	7	4.1	°C/W
R _{θJC(bot)} Junction-to-case (bottom) thermal resistance	—	—	—	1	°C/W

- (1) For more information about traditional and new thermal metrics, see the *Semiconductor and IC Package Thermal Metrics* application report, [SPRA953](#).
(2) No heat sink.

5.5 Electrical Characteristics

Unless otherwise specified, these specifications apply $-55^{\circ}\text{C} \leq T_j \leq 150^{\circ}\text{C}$ for the LM137, $0^{\circ}\text{C} \leq T_j \leq 125^{\circ}\text{C}$ for the LM337-N; $V_{\text{IN}} - V_{\text{OUT}} = 5\text{ V}$; and $I_{\text{OUT}} = 0.1\text{ A}$ for the TO package and $I_{\text{OUT}} = 0.5\text{ A}$ for the SOT-223 and TO-220 packages. Although power dissipation is internally limited, these specifications are applicable for power dissipations of 2 W for the TO and SOT-223, and 20 W for the TO-220. I_{MAX} is 1.5 A for the SOT-223 and TO-220 packages, and 0.2 A for the TO package.

PARAMETER	TEST CONDITIONS	LM137			LM337-N			UNIT	
		MIN	TYP	MAX	MIN	TYP	MAX		
Line regulation	$T_j = 25^{\circ}\text{C}$, $3\text{ V} \leq V_{\text{IN}} - V_{\text{OUT}} \leq 40\text{ V}^{(1)}$ $I_L = 10\text{ mA}$		0.01	0.02		0.01	0.04	%/V	
Load regulation	$T_j = 25^{\circ}\text{C}$, $10\text{ mA} \leq I_{\text{OUT}} \leq I_{\text{MAX}}$		0.3%	0.5%		0.3%	1%		
Thermal regulation	$T_j = 25^{\circ}\text{C}$, 10-ms Pulse		0.002	0.02		0.003	0.04	%/W	
Adjustment pin current			65	100		65	100	μA	
Adjustment pin current charge	$10\text{ mA} \leq I_L \leq I_{\text{MAX}}$ $3\text{ V} \leq V_{\text{IN}} - V_{\text{OUT}} \leq 40\text{ V}$, $T_A = 25^{\circ}\text{C}$		2	5		2	5	μA	
Reference voltage	$3\text{ V} \leq V_{\text{IN}} - V_{\text{OUT}} \leq 40\text{ V}$, ⁽²⁾ $10\text{ mA} \leq I_{\text{OUT}} \leq I_{\text{MAX}}$, $P \leq P_{\text{MAX}}$	$T_j = 25^{\circ}\text{C}$ ⁽²⁾	-1.225	-1.25	-1.275	-1.213	-1.25	-1.287	V
		$-55^{\circ}\text{C} \leq T_j \leq 150^{\circ}\text{C}$	-1.2	-1.25	-1.3	-1.2	-1.25	-1.3	V
Line regulation	$3\text{ V} \leq V_{\text{IN}} - V_{\text{OUT}} \leq 40\text{ V}$, ⁽¹⁾		0.02	0.05		0.02	0.07	%/V	
Load regulation	$10\text{ mA} \leq I_{\text{OUT}} \leq I_{\text{MAX}}$, ⁽¹⁾		0.3%	1%		0.3%	1.5%		
Temperature stability	$T_{\text{MIN}} \leq T_j \leq T_{\text{MAX}}$		0.6%			0.6%			
Minimum load current	$ V_{\text{IN}} - V_{\text{OUT}} \leq 40\text{ V}$		2.5	5		2.5	10	mA	
	$ V_{\text{IN}} - V_{\text{OUT}} \leq 10\text{ V}$		1.2	3		1.5	6	mA	
Current limit	$ V_{\text{IN}} - V_{\text{OUT}} \leq 15\text{ V}$	K, DCY and NDE package	1.5	2.2	3.5	1.5	2.2	3.7	A
		NDT package	0.5	0.8	1.8	0.5	0.8	1.9	A
	$ V_{\text{IN}} - V_{\text{OUT}} = 40\text{ V}$, $T_j = 25^{\circ}\text{C}$	K, DCY and NDE package	0.24	0.4		0.15	0.4		A
		NDT package	0.15	0.17		0.1	0.17		A
RMS output noise, % of V_{OUT}	$T_j = 25^{\circ}\text{C}$, $10\text{ Hz} \leq f \leq 10\text{ kHz}$		0.003%			0.003%			
Ripple rejection ratio	$V_{\text{OUT}} = -10\text{ V}$, $f = 120\text{ Hz}$		60			60		dB	
	$C_{\text{ADJ}} = 10\text{ }\mu\text{F}$		66	77		66	77	dB	
Long-term stability	$T_j = 125^{\circ}\text{C}$, 1000 Hours		0.3%	1%		0.3%	1%		

- (1) Regulation is measured at constant junction temperature, using pulse testing with a low duty cycle. Changes in output voltage due to heating effects are covered under the specification for thermal regulation. Load regulation is measured on the output pin at a point 1/8 in. below the base of the TO packages.
- (2) Selected devices with tightened tolerance reference voltage available.

5.6 Typical Characteristics

(NDE Package)

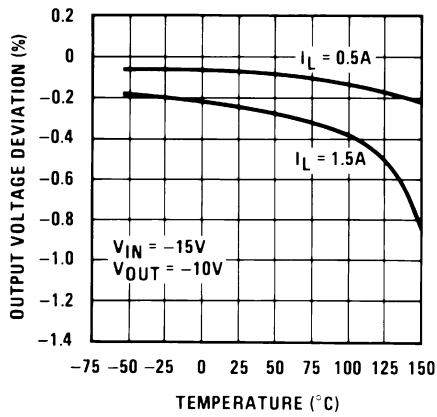

Figure 5-1. Load Regulation

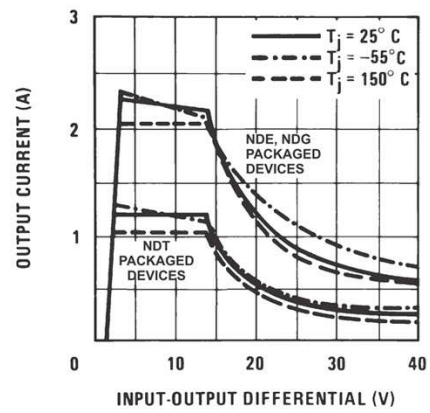

Figure 5-2. Current Limit

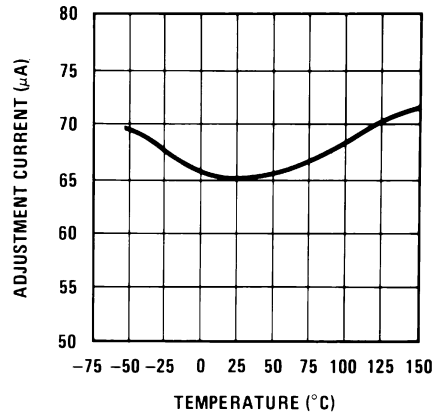

Figure 5-3. Adjustment Current

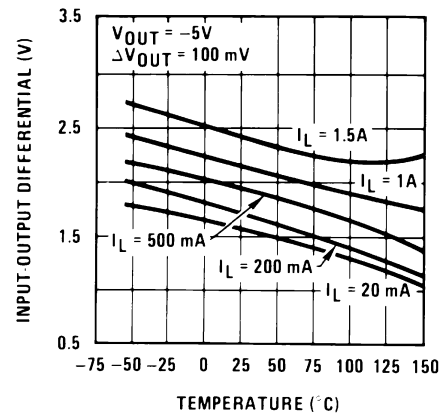

Figure 5-4. Dropout Voltage

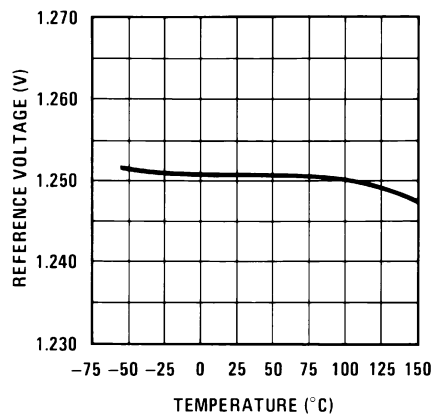

Figure 5-5. Temperature Stability

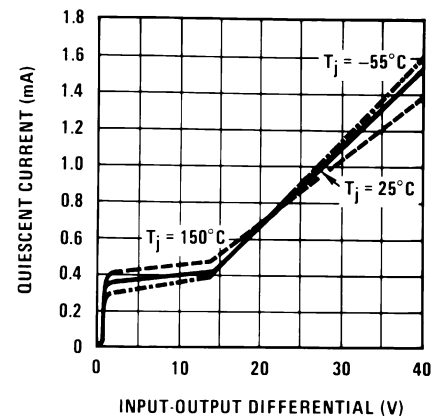

Figure 5-6. Minimum Operating Current

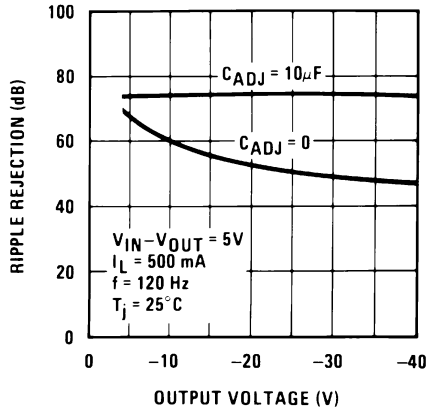

Figure 5-7. Ripple Rejection

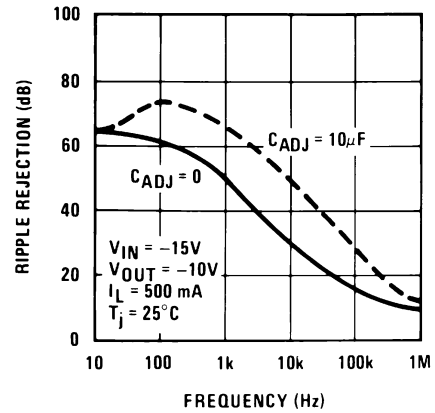

Figure 5-8. Ripple Rejection

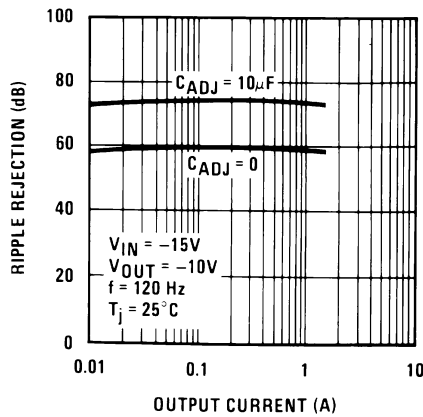

Figure 5-9. Ripple Rejection

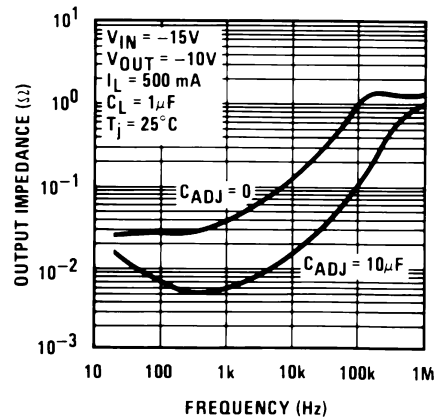

Figure 5-10. Output Impedance

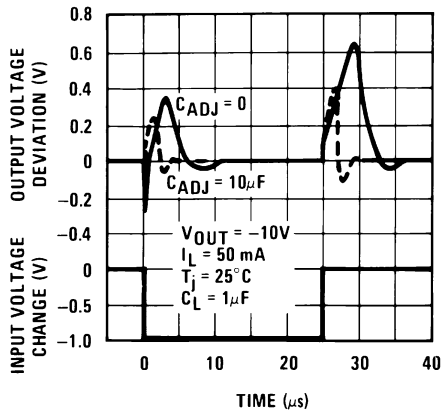

Figure 5-11. Line Transient Response

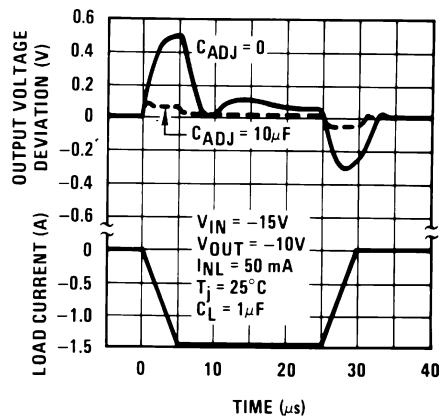

Figure 5-12. Load Transient Response

6 Detailed Description

6.1 Overview

In operation, the LM137 and LM337-N develops a nominal -1.25-V reference voltage between the output and adjustment terminal. The reference voltage is impressed across program resistor R1 (120 Ω for example) and, because the voltage is constant, a constant current then flows through the output set resistor R2, giving an output voltage calculated by Equation 1.

$$-V_{OUT} = -1.25V \left(1 + \frac{R2}{120} \right) + (-I_{ADJ} \times R2) \quad (1)$$

6.2 Functional Block Diagram

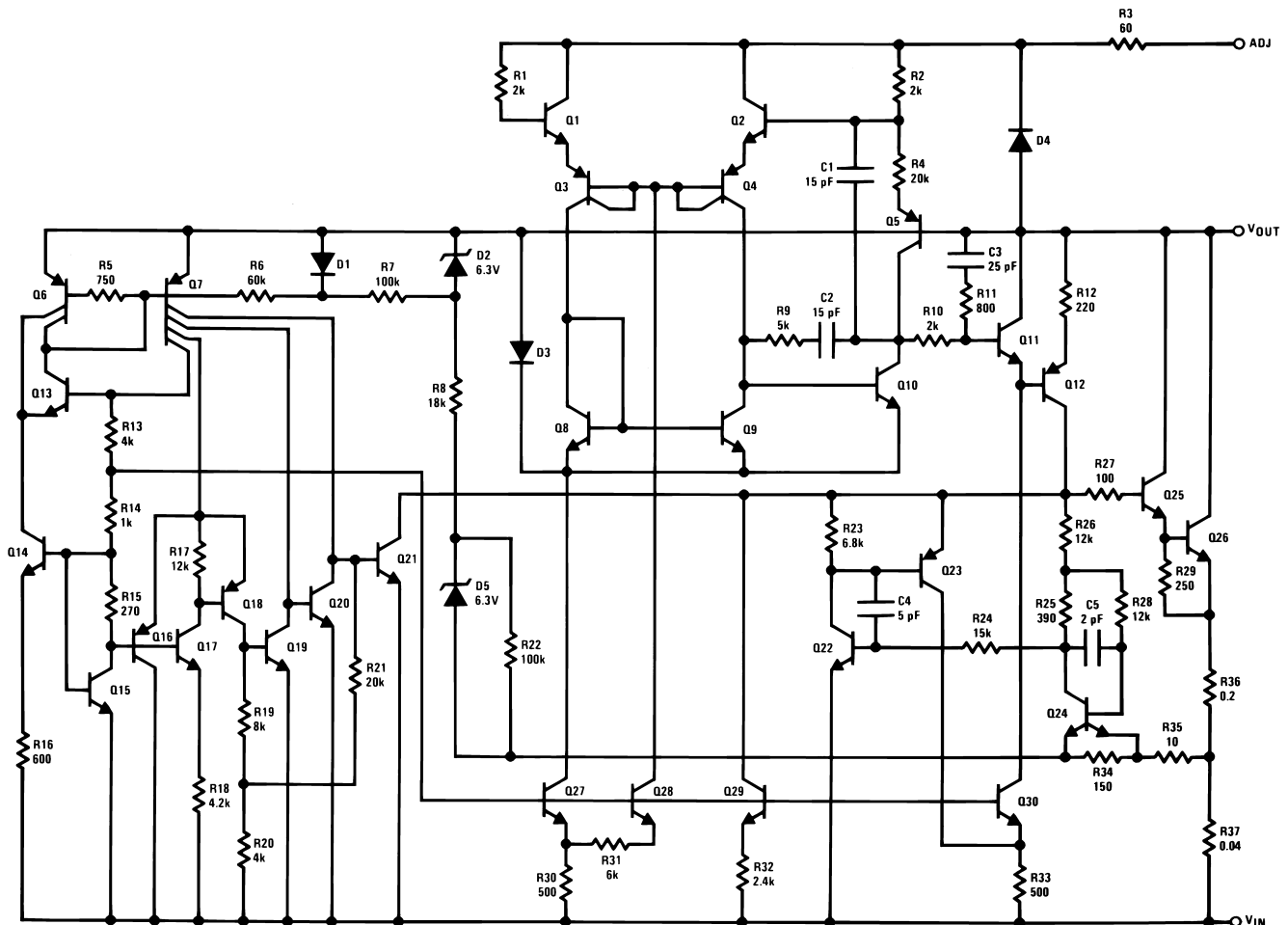

6.3 Feature Description

6.3.1 Thermal Regulation

When power is dissipated in an IC, a temperature gradient occurs across the IC chip affecting the individual IC circuit components. With an IC regulator, this gradient can be especially severe because power dissipation is large. Thermal regulation is the effect of these temperature gradients on output voltage (in percentage output change) per Watt of power change in a specified time. Thermal regulation error is independent of electrical regulation or temperature coefficient, and occurs within 5 ms to 50 ms after a change in power dissipation. Thermal regulation depends on IC layout as well as electrical design. The thermal regulation of a voltage regulator is defined as the percentage change of V_{OUT} , per Watt, within the first 10 ms after a step of power is applied. The LM137 device's specification is 0.02%/W, maximum.

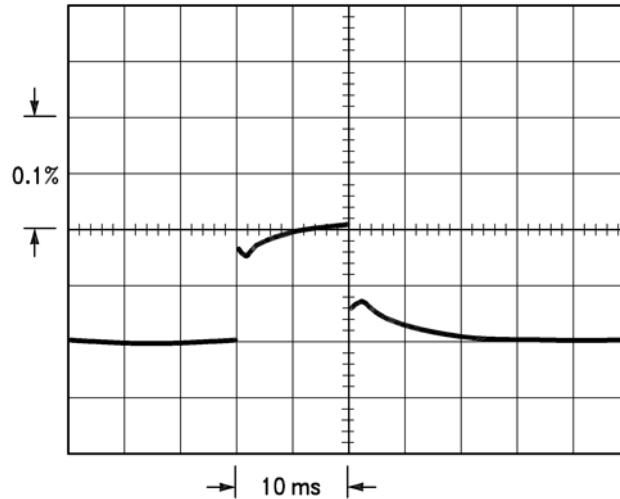

LM137 $V_{OUT} = -10\text{ V}$ $V_{IN} = -40\text{ V}$ $I_{IL} = 0\text{ A} \rightarrow 0.25\text{ A} \rightarrow 0\text{ A}$ Vertical sensitivity, 5 mV/div

Figure 6-1. Output Drift (10W Pulse for 10ms)

In [Figure 6-1](#), a typical LM137 device's output drifts only 3 mV (or 0.03% of $V_{OUT} = -10\text{ V}$) when a 10-W pulse is applied for 10 ms. This performance is thus well inside the specification limit of $0.02\%/W \times 10\text{ W} = 0.2\%$ maximum. When the 10-W pulse is ended, the thermal regulation again shows a 3-mV step at the LM137 chip cools off.

Note

The load regulation error of about 8 mV (0.08%) is additional to the thermal regulation error.

In [Figure 6-2](#), when the 10-W pulse is applied for 100 ms, the output drifts only slightly beyond the drift in the first 10 ms, and the thermal error stays well within 0.1% (10 mV).

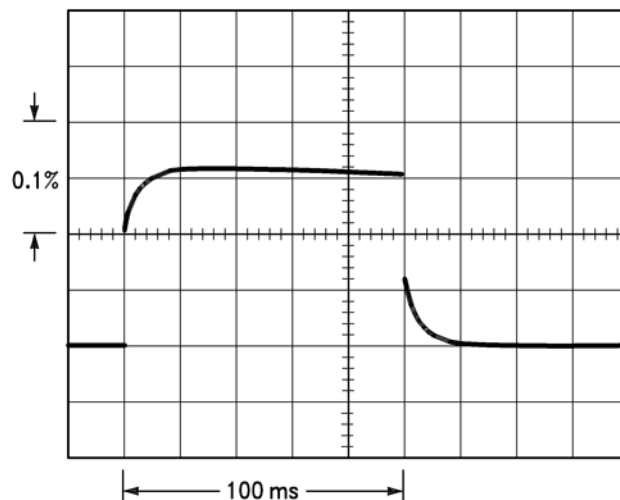

LM137 $V_{OUT} = -10\text{ V}$ $V_{IN} = -40\text{ V}$ $I_L = 0\text{ A} \rightarrow 0.25\text{ A} \rightarrow 0\text{ A}$ Horizontal sensitivity, 20 ms/div

Figure 6-2. Output Drift (10-W Pulse for 100 ms)

6.4 Device Functional Modes

6.4.1 Protection Diodes

When external capacitors are used with any IC regulator, it is sometimes necessary to add protection diodes to prevent the capacitors from discharging through low current points into the regulator. Most 10- μF capacitors have low enough internal series resistance to deliver 20-A spikes when shorted. Although the surge is short, there is enough energy to damage parts of the IC.

When an output capacitor is connected to a negative output regulator and the input is shorted, the output capacitor pulls current out of the output of the regulator. The current depends on the value of the capacitor, the output voltage of the regulator, and the rate at which V_{IN} is shorted to ground.

The bypass capacitor on the adjustment terminal can discharge through a low current junction. Discharge occurs when either the input, or the output, is shorted. Figure 6-3 shows the placement of the protection diodes.

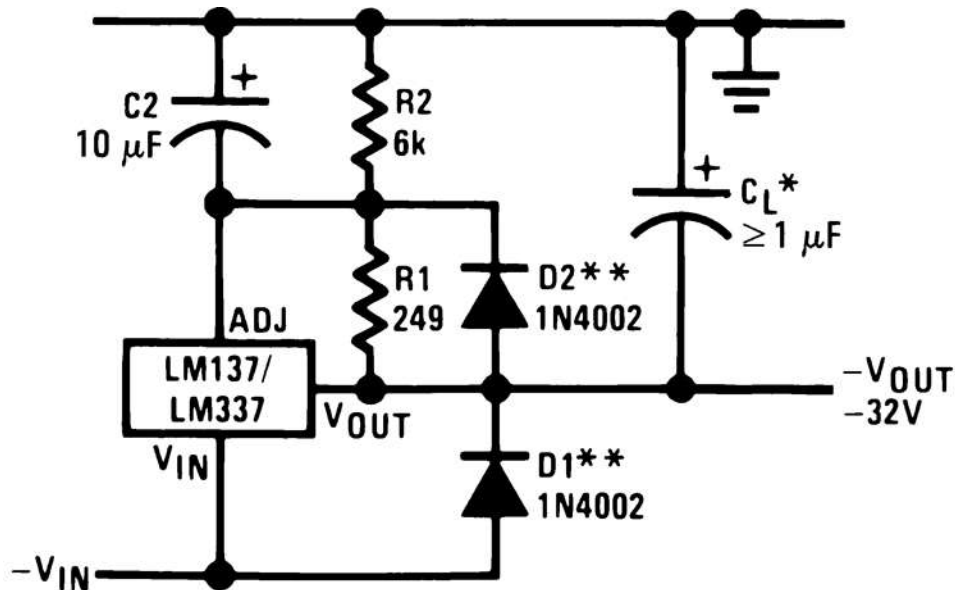

*When C_L is larger than 20 μF , D1 protects the LM137 in case the input supply is shorted **When C_2 is larger than 10 μF and $-V_{\text{OUT}}$ is larger than -25V , D2 protects the LM137 in case the output is shorted

Figure 6-3. Regulator With Protection Diodes

7 Application and Implementation

Note

Information in the following applications sections is not part of the TI component specification, and TI does not warrant its accuracy or completeness. TI's customers are responsible for determining suitability of components for their purposes, as well as validating and testing their design implementation to confirm system functionality.

7.1 Application Information

The LM137 and LM337-N are versatile, high performance, negative output linear regulators with high accuracy and a wide temperature range. An output capacitor can be added to further improve transient response, and the ADJ pin can be bypassed to achieve very high ripple-rejection ratios. The device's functionality can be utilized in many different applications that require negative voltage supplies, such as bipolar amplifiers, operational amplifiers, and constant current regulators.

7.2 Typical Applications

7.2.1 Adjustable Negative Voltage Regulator

The LM137 and LM337-N can be used as a simple, negative output regulator to enable a variety of output voltages needed for demanding applications. By using an adjustable R2 resistor, a variety of negative output voltages can be made possible as shown in [Figure 7-1](#).

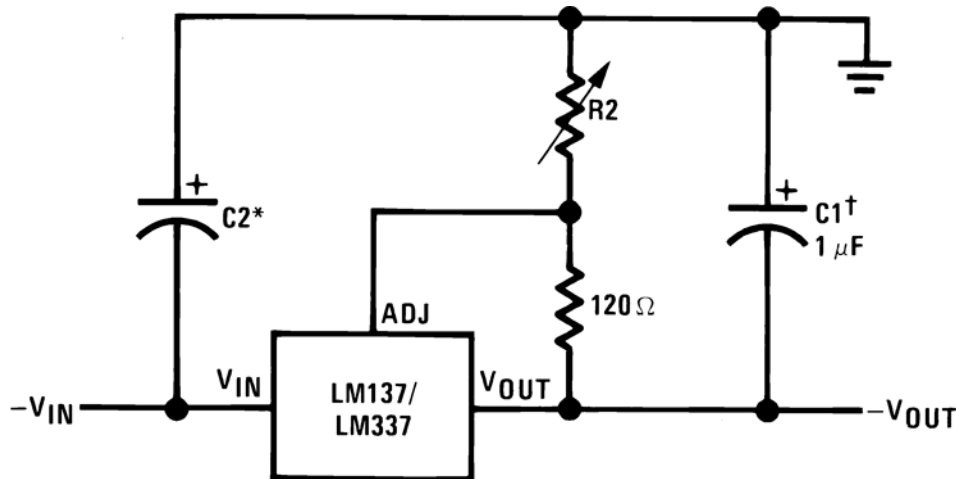

Full output current not available at high input-output voltages †C1 = 1-μF solid tantalum or 10-μF aluminum electrolytic required for stability *C2 = 1-μF solid tantalum is required only if regulator is more than 4 inches from power-supply filter capacitor Output capacitors in the range of 1 μF to 1000 μF of aluminum or tantalum electrolytic are commonly used to provide improved output impedance and rejection of transients

Figure 7-1. Adjustable Negative Voltage Regulator

$$-V_{OUT} = -1.25V \left(1 + \frac{R2}{120} \right) + (-I_{ADJ} \times R2) \quad (2)$$

7.2.1.1 Design Requirements

The device component count is very minimal, employing two resistors as part of a voltage divider circuit and an output capacitor for load regulation. An input capacitor is needed if the device is more than 4 inches from the filter capacitors.

7.2.1.2 Detailed Design Procedure

The output voltage is set based on the selection of the two resistors, R1 and R2, as shown in [Figure 7-1](#).

7.2.1.3 Application Curve

As shown in [Figure 7-2](#), the maximum output current capability is limited by the input-output voltage differential, package type, and junction temperature.

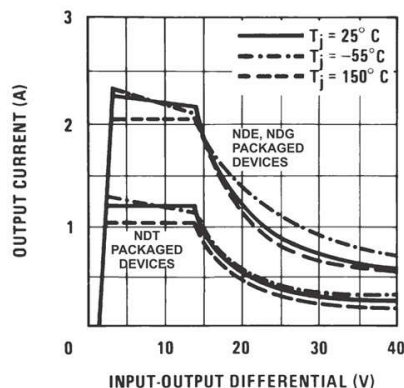
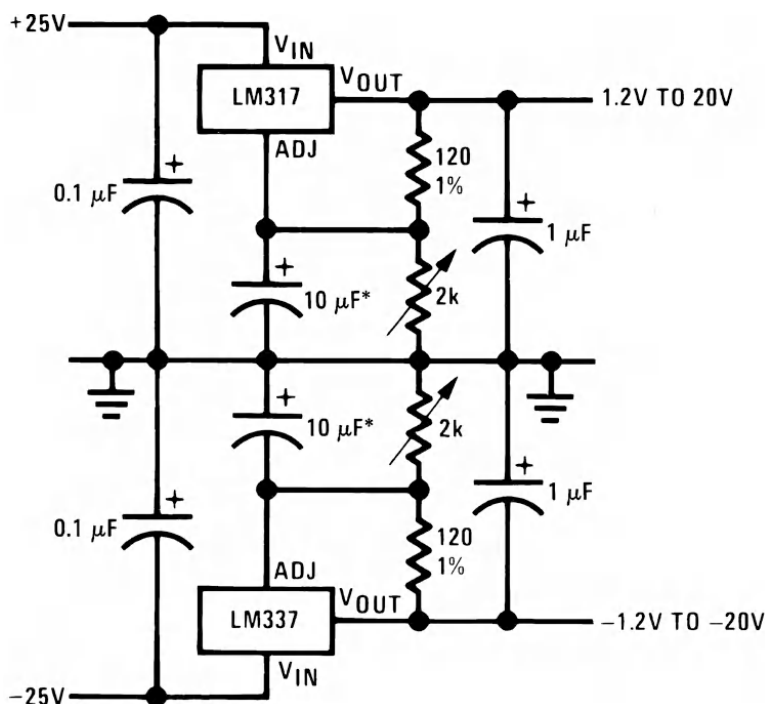

Figure 7-2. Current Limit

7.2.2 Adjustable Lab Voltage Regulator

The LM337-N can be combined with a positive regulator such as the LM317-N to provide both a positive and negative voltage rail. This can be useful in applications that use bi-directional amplifiers and dual-supply operational amplifiers.



Full output current not available at high input-output voltages *The 10 μF capacitors are optional to improve ripple rejection

7.2.3 Current Regulator

A simple, fixed current regulator can be made by placing a resistor between the V_{OUT} and ADJ pins of the LM137. By regulating a constant 1.25 V between these two terminals, a constant current can be delivered.

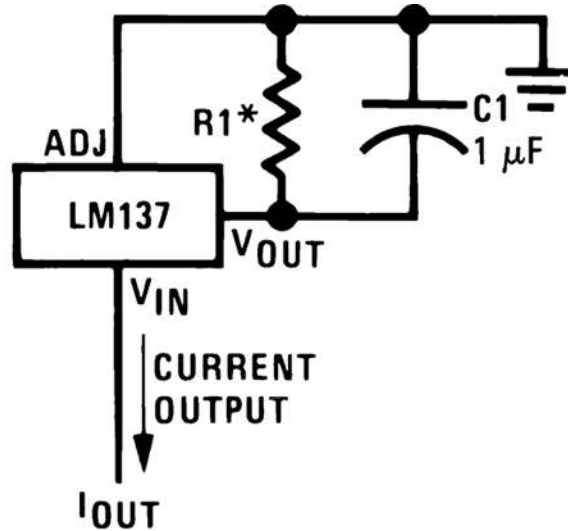

$$I_{OUT} = \frac{1.250V}{R1} \tag{3}$$

$$*0.8 \Omega \leq R1 \leq 120 \Omega \tag{4}$$

7.2.4 -5.2-V Regulator with Electronic Shutdown

The LM337-N can be used with a PNP transistor to provide shutdown control from a TTL control signal. The PNP can short or open the ADJ pin to GND. When ADJ is shorted to GND by the PNP, the output is -1.3V. When ADJ is disconnected from GND by the PNP, then the LM337-N outputs the programmed output of -5.2 V.

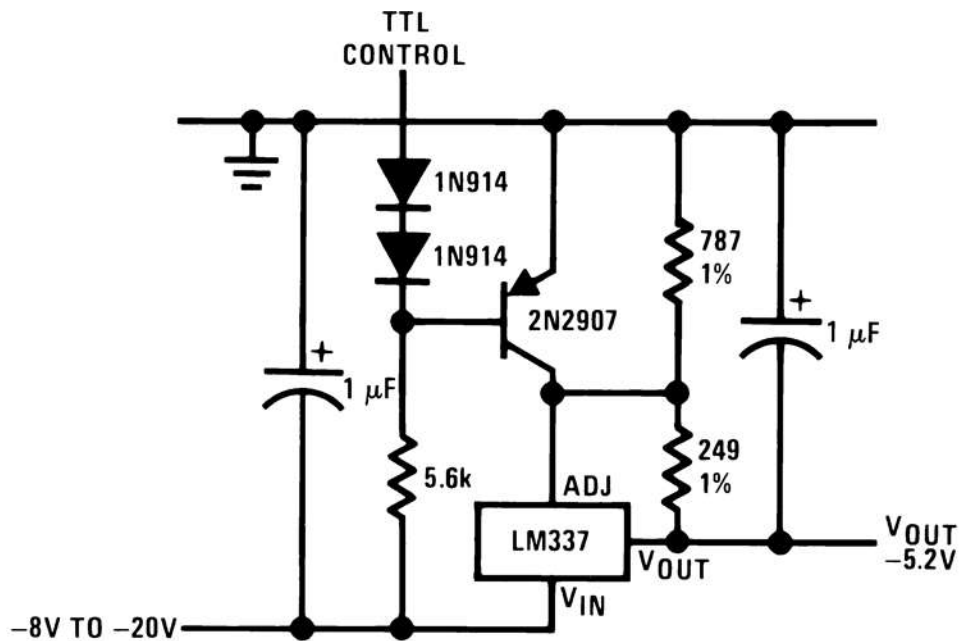

Minimum output ≈ -1.3 V when control input is low

7.2.5 High Stability –10-V Regulator

Using a high stability shunt voltage reference in the feedback path, such as the LM329, provides damping necessary for a stable, low noise output.

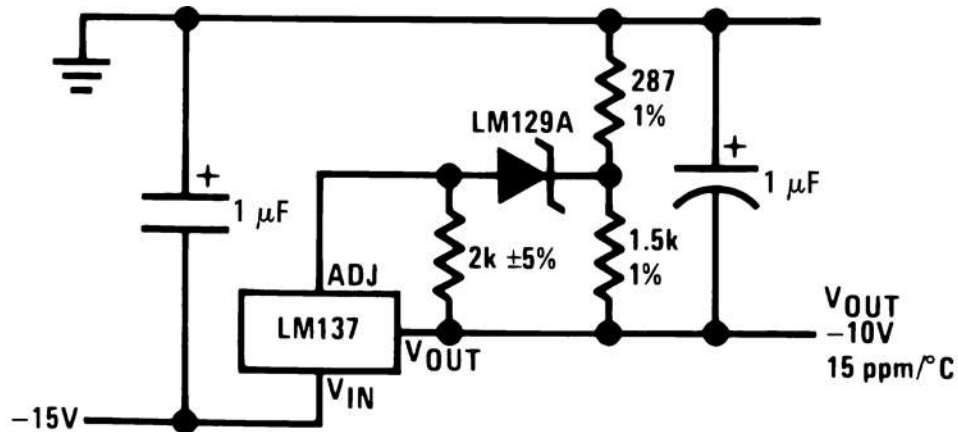

8 Power Supply Recommendations

The input supply to the LM137 and LM337-N must be kept at a voltage level such that its maximum input to output differential voltage rating is not exceeded. The minimum dropout voltage must also be met with extra headroom when possible to keep the LM137 and LM337-N in regulation. TI recommends an input capacitor, especially when the input pin is placed more than 4 inches away from the power-supply filter capacitor.

9 Layout

9.1 Layout Guidelines

Some layout guidelines must be followed to ensure proper regulation of the output voltage with minimum noise. Traces carrying the load current must be wide to reduce the amount of parasitic trace inductance and the feedback loop from V_{OUT} to ADJ must be kept as short as possible. To improve PSRR, a bypass capacitor can be placed at the ADJ pin and must be placed as close as possible to the IC. In cases when V_{IN} shorts to ground, an external diode must be placed from V_{IN} to V_{OUT} to divert the surge current into the output capacitor and protect the IC. Similarly, in cases when a large bypass capacitor is placed at the ADJ pin and V_{OUT} shorts to ground, an external diode must be placed from V_{OUT} to ADJ to provide a path for the bypass capacitor to discharge. These diodes must be placed close to the corresponding IC pins to increase their effectiveness.

9.2 Layout Example

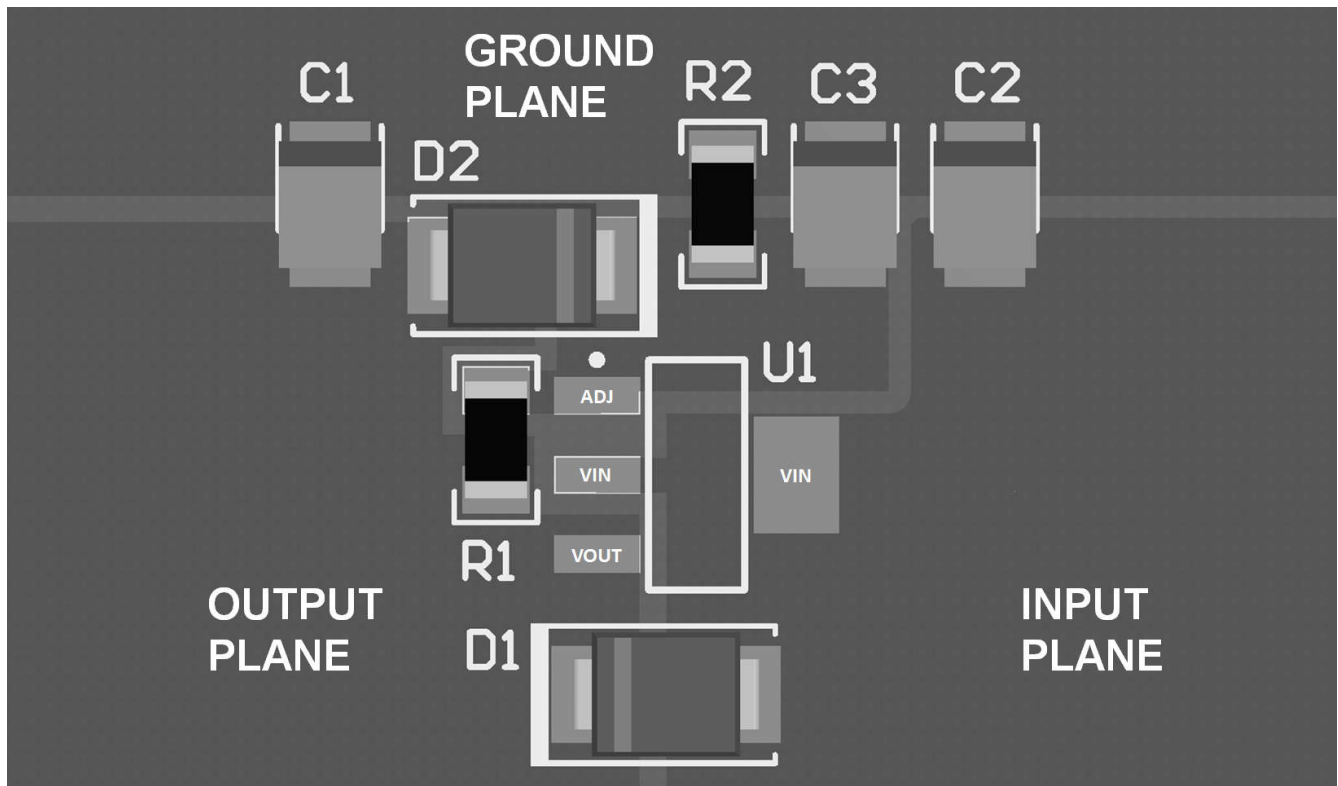

Figure 9-1. Layout Example (SOT-223)

9.3 Thermal Considerations

9.3.1 Heatsinking SOT-223 Package Parts

The SOT-223 DCY packages use a copper plane on the PCB and the PCB itself as a heatsink. To optimize the heat sinking ability of the plane and PCB, solder the tab of the package to the plane.

Figure 9-2 and Figure 9-3 show the information for the SOT-223 package. Figure 9-3 assumes a $\theta_{(J-A)}$ of 75°C/W for 1 ounce copper and 51°C/W for 2 ounce copper and a maximum junction temperature of 125°C.

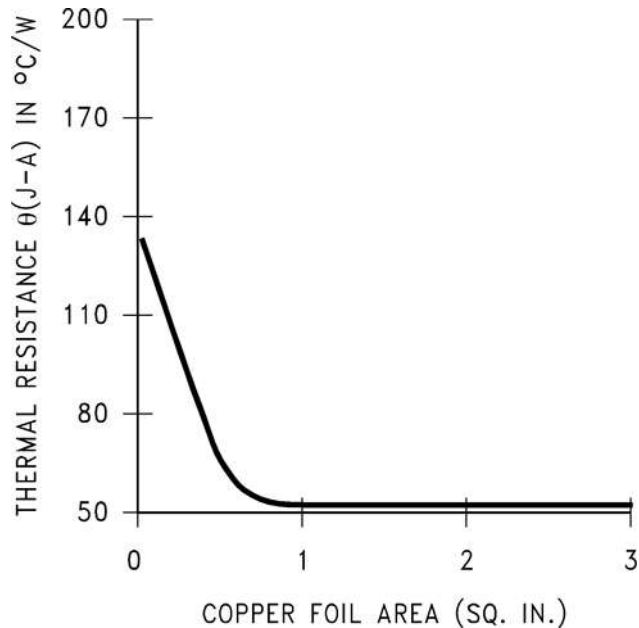

Figure 9-2. $\theta_{(J-A)}$ vs Copper (2 ounce) Area for the SOT-223 Package

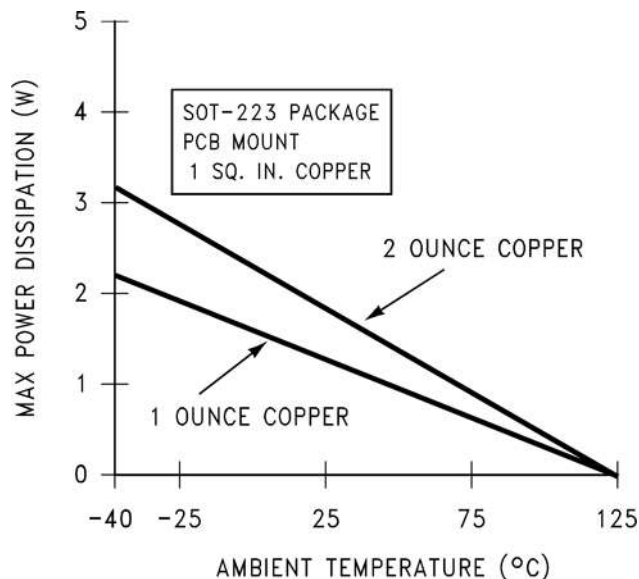

Figure 9-3. Maximum Power Dissipation vs T_{AMB} for the SOT-223 Package

See AN-1028, [SNVA036](#), for power enhancement techniques to be used with the SOT-223 package.

10 Device and Documentation Support

10.1 Documentation Support

10.1.1 Related Documentation

For related documentation see the following:

AN-1028, [SNVA036](#)

10.2 Receiving Notification of Documentation Updates

To receive notification of documentation updates, navigate to the device product folder on [ti.com](#). Click on *Notifications* to register and receive a weekly digest of any product information that has changed. For change details, review the revision history included in any revised document.

10.3 Support Resources

[TI E2E™ support forums](#) are an engineer's go-to source for fast, verified answers and design help — straight from the experts. Search existing answers or ask your own question to get the quick design help you need.

Linked content is provided "AS IS" by the respective contributors. They do not constitute TI specifications and do not necessarily reflect TI's views; see TI's [Terms of Use](#).

10.4 Trademarks

TI E2E™ is a trademark of Texas Instruments.

All trademarks are the property of their respective owners.

10.5 Electrostatic Discharge Caution



This integrated circuit can be damaged by ESD. Texas Instruments recommends that all integrated circuits be handled with appropriate precautions. Failure to observe proper handling and installation procedures can cause damage.

ESD damage can range from subtle performance degradation to complete device failure. Precision integrated circuits may be more susceptible to damage because very small parametric changes could cause the device not to meet its published specifications.

10.6 Glossary

[TI Glossary](#) This glossary lists and explains terms, acronyms, and definitions.

11 Revision History

NOTE: Page numbers for previous revisions may differ from page numbers in the current version.

Changes from Revision E (June 2015) to Revision F (May 2026)	Page
• Updated the numbering format for tables, figures, and cross-references throughout the document.....	1
<hr/>	
Changes from Revision D (April 2013) to Revision E (June 2015)	Page
• Added <i>ESD Ratings</i> table, <i>Feature Description</i> section, <i>Device Functional Modes, Application and Implementation</i> section, <i>Power Supply Recommendations</i> section, <i>Layout</i> section, <i>Device and Documentation Support</i> section, and <i>Mechanical, Packaging, and Orderable Information</i> section.....	1
• Deleted soldering information from <i>Absolute Maximum Ratings</i>	4
<hr/>	
Changes from Revision C (April 2013) to Revision D (April 2013)	Page
• Changed layout of National Data Sheet to TI format.....	6

12 Mechanical, Packaging, and Orderable Information

The following pages include mechanical, packaging, and orderable information. This information is the most current data available for the designated devices. This data is subject to change without notice and revision of this document. For browser-based versions of this data sheet, refer to the left-hand navigation.

PACKAGING INFORMATION

Orderable part number	Status (1)	Material type (2)	Package Pins	Package qty Carrier	RoHS (3)	Lead finish/ Ball material (4)	MSL rating/ Peak reflow (5)	Op temp (°C)	Part marking (6)
LM137H	Active	Production	TO (NDT) 3	500 BULK	Yes	AU	Level-1-NA-UNLIM	-55 to 150	(LM137HP+, LM137H P+)
LM137H/NOPB	Active	Production	TO (NDT) 3	500 BULK	Yes	AU	Level-1-NA-UNLIM	-55 to 150	(LM137HP+, LM137H P+)
LM337IMP/NOPB	Active	Production	SOT-223 (DCY) 4	1000 SMALL T&R	Yes	SN	Level-1-260C-UNLIM	-40 to 125	N02A
LM337IMP/NOPB.B	Active	Production	SOT-223 (DCY) 4	1000 SMALL T&R	Yes	SN	Level-1-260C-UNLIM	-40 to 125	N02A
LM337IMPX/NOPB	Active	Production	SOT-223 (DCY) 4	2000 LARGE T&R	Yes	SN	Level-1-260C-UNLIM	-40 to 125	N02A
LM337IMPX/NOPB.B	Active	Production	SOT-223 (DCY) 4	2000 LARGE T&R	Yes	SN	Level-1-260C-UNLIM	-40 to 125	N02A
LM337T/LF01	Active	Production	TO-220 (NDG) 3	45 TUBE	ROHS Exempt	SN	Level-3-245C-168 HR	0 to 125	LM337T P+
LM337T/LF01.B	Active	Production	TO-220 (NDG) 3	45 TUBE	ROHS Exempt	SN	Level-3-245C-168 HR	0 to 125	LM337T P+
LM337T/NOPB	Active	Production	TO-220 (NDE) 3	45 TUBE	ROHS Exempt	SN	Level-1-NA-UNLIM	0 to 125	LM337T P+
LM337T/NOPB.B	Active	Production	TO-220 (NDE) 3	45 TUBE	ROHS Exempt	SN	Level-1-NA-UNLIM	0 to 125	LM337T P+

(1) **Status:** For more details on status, see our [product life cycle](#).

(2) **Material type:** When designated, preproduction parts are prototypes/experimental devices, and are not yet approved or released for full production. Testing and final process, including without limitation quality assurance, reliability performance testing, and/or process qualification, may not yet be complete, and this item is subject to further changes or possible discontinuation. If available for ordering, purchases will be subject to an additional waiver at checkout, and are intended for early internal evaluation purposes only. These items are sold without warranties of any kind.

(3) **RoHS values:** Yes, No, RoHS Exempt. See the [TI RoHS Statement](#) for additional information and value definition.

(4) **Lead finish/Ball material:** Parts may have multiple material finish options. Finish options are separated by a vertical ruled line. Lead finish/Ball material values may wrap to two lines if the finish value exceeds the maximum column width.

(5) **MSL rating/Peak reflow:** The moisture sensitivity level ratings and peak solder (reflow) temperatures. In the event that a part has multiple moisture sensitivity ratings, only the lowest level per JEDEC standards is shown. Refer to the shipping label for the actual reflow temperature that will be used to mount the part to the printed circuit board.

(6) **Part marking:** There may be an additional marking, which relates to the logo, the lot trace code information, or the environmental category of the part.

Multiple part markings will be inside parentheses. Only one part marking contained in parentheses and separated by a "~" will appear on a part. If a line is indented then it is a continuation of the previous line and the two combined represent the entire part marking for that device.

Important Information and Disclaimer: The information provided on this page represents TI's knowledge and belief as of the date that it is provided. TI bases its knowledge and belief on information provided by third parties, and makes no representation or warranty as to the accuracy of such information. Efforts are underway to better integrate information from third parties. TI has taken and continues to take reasonable steps to provide representative and accurate information but may not have conducted destructive testing or chemical analysis on incoming materials and chemicals. TI and TI suppliers consider certain information to be proprietary, and thus CAS numbers and other limited information may not be available for release.

In no event shall TI's liability arising out of such information exceed the total purchase price of the TI part(s) at issue in this document sold by TI to Customer on an annual basis.

TAPE AND REEL INFORMATION

QUADRANT ASSIGNMENTS FOR PIN 1 ORIENTATION IN TAPE

*All dimensions are nominal

Device	Package Type	Package Drawing	Pins	SPQ	Reel Diameter (mm)	Reel Width W1 (mm)	A0 (mm)	B0 (mm)	K0 (mm)	P1 (mm)	W (mm)	Pin1 Quadrant
LM337IMP/NOPB	SOT-223	DCY	4	1000	330.0	16.4	7.0	7.5	2.2	12.0	16.0	Q3
LM337IMPX/NOPB	SOT-223	DCY	4	2000	330.0	16.4	7.0	7.5	2.2	12.0	16.0	Q3

TAPE AND REEL BOX DIMENSIONS



*All dimensions are nominal

Device	Package Type	Package Drawing	Pins	SPQ	Length (mm)	Width (mm)	Height (mm)
LM337IMP/NOPB	SOT-223	DCY	4	1000	367.0	367.0	35.0
LM337IMPX/NOPB	SOT-223	DCY	4	2000	367.0	367.0	35.0

TUBE

*All dimensions are nominal

Device	Package Name	Package Type	Pins	SPQ	L (mm)	W (mm)	T (μm)	B (mm)
LM337T/LF01	NDG	TO-220	3	45	502	25	8204.2	9.19
LM337T/LF01.B	NDG	TO-220	3	45	502	25	8204.2	9.19
LM337T/NOPB	NDE	TO-220	3	45	502	33	6985	4.06
LM337T/NOPB.B	NDE	TO-220	3	45	502	33	6985	4.06

NDE0003B

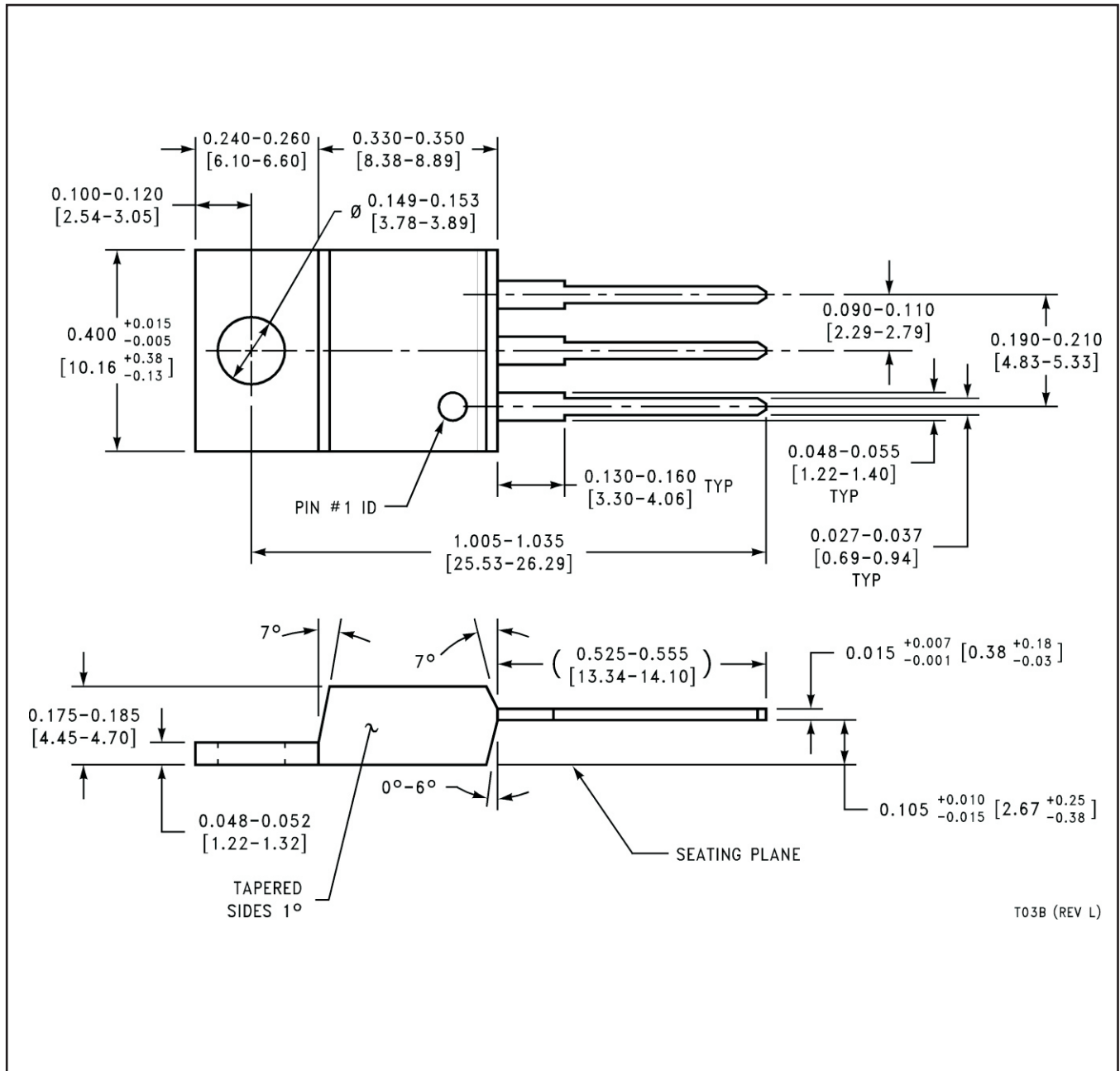

DCY (R-PDSO-G4)

PLASTIC SMALL-OUTLINE

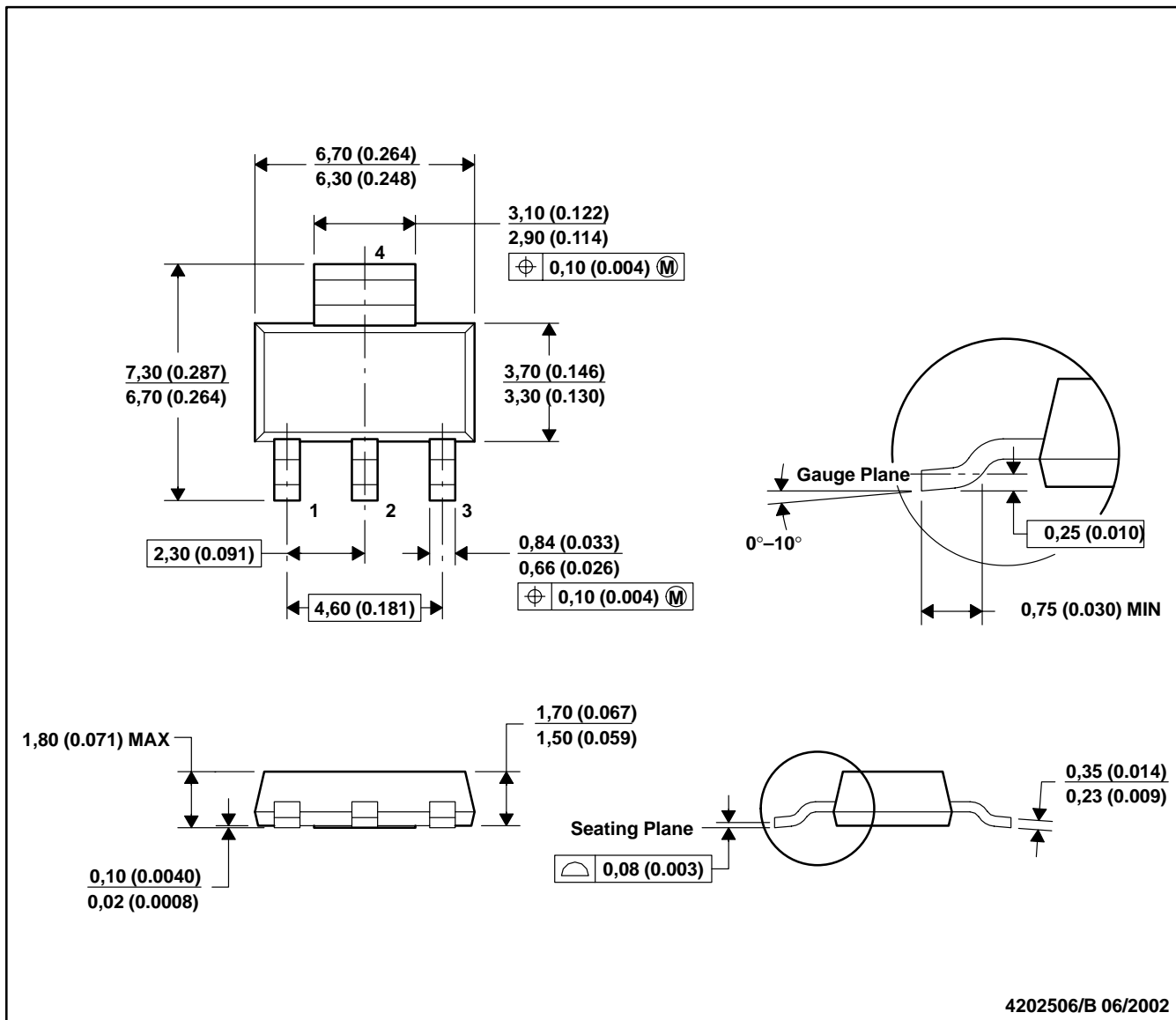

- NOTES: A. All linear dimensions are in millimeters (inches).
 B. This drawing is subject to change without notice.
 C. Body dimensions do not include mold flash or protrusion.
 D. Falls within JEDEC TO-261 Variation AA.

NDT0003A

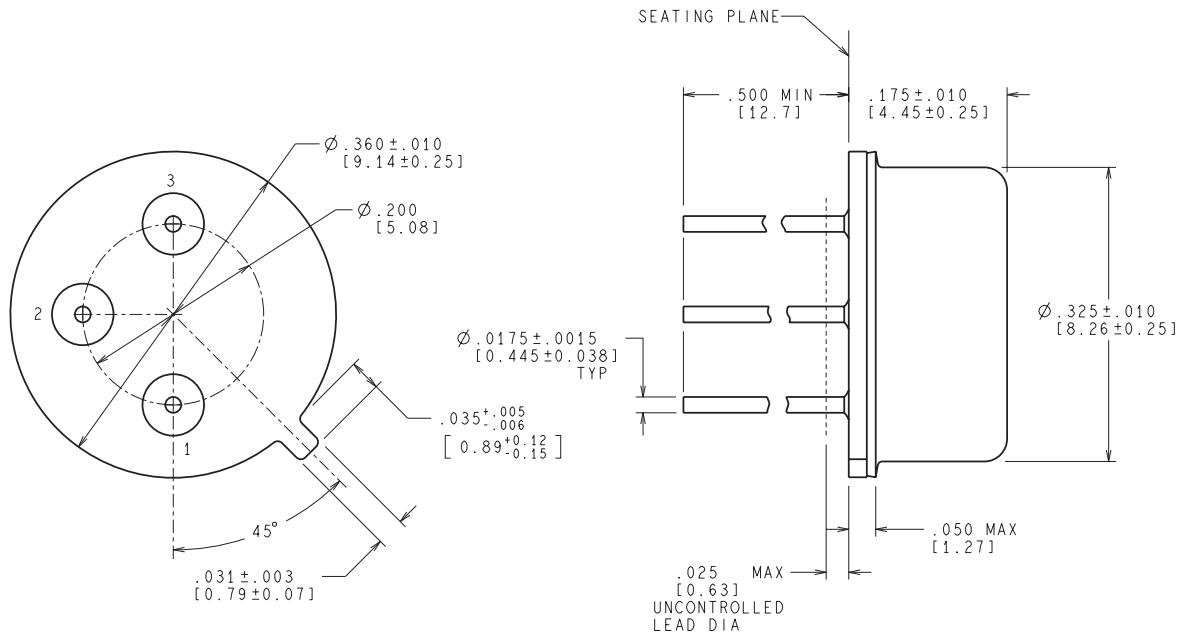

CONTROLLING DIMENSION IS INCH
VALUES IN [] ARE MILLIMETERS

MIL-PRF-38535
CONFIGURATION CONTROL

H03A (Rev D)



PACKAGE OUTLINE

NDG0003F

TO-220 - 4.69 mm max height

TRANSISTOR OUTLINE

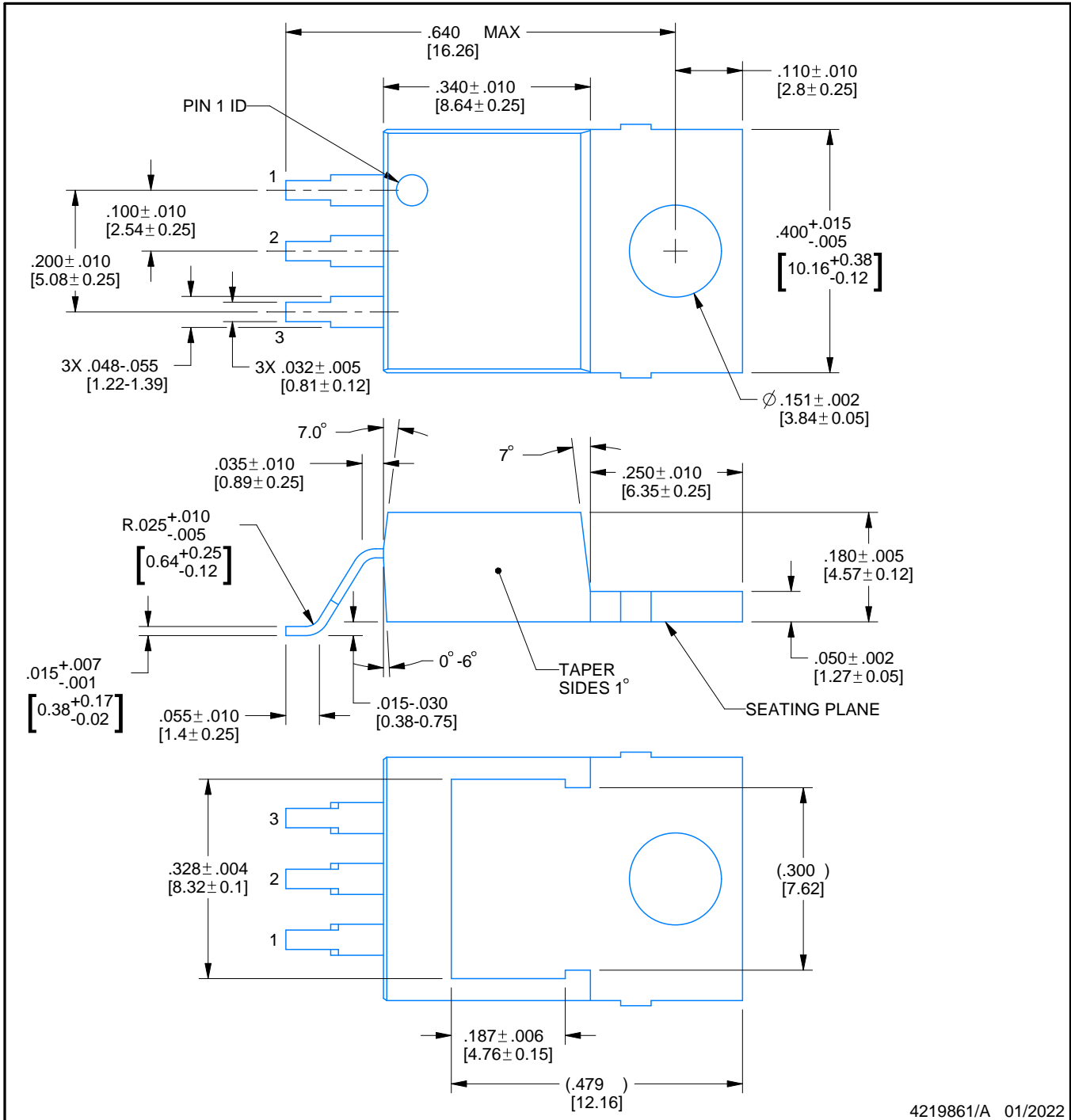

4219861/A 01/2022

NOTES:

1. All controlling linear dimensions are in inches. Dimensions in brackets are in millimeters. Any dimension in brackets or parenthesis are for reference only. Dimensioning and tolerancing per ASME Y14.5M.
2. This drawing is subject to change without notice.

EXAMPLE BOARD LAYOUT

NDG0003F

TO-220 - 4.69 mm max height

TRANSISTOR OUTLINE

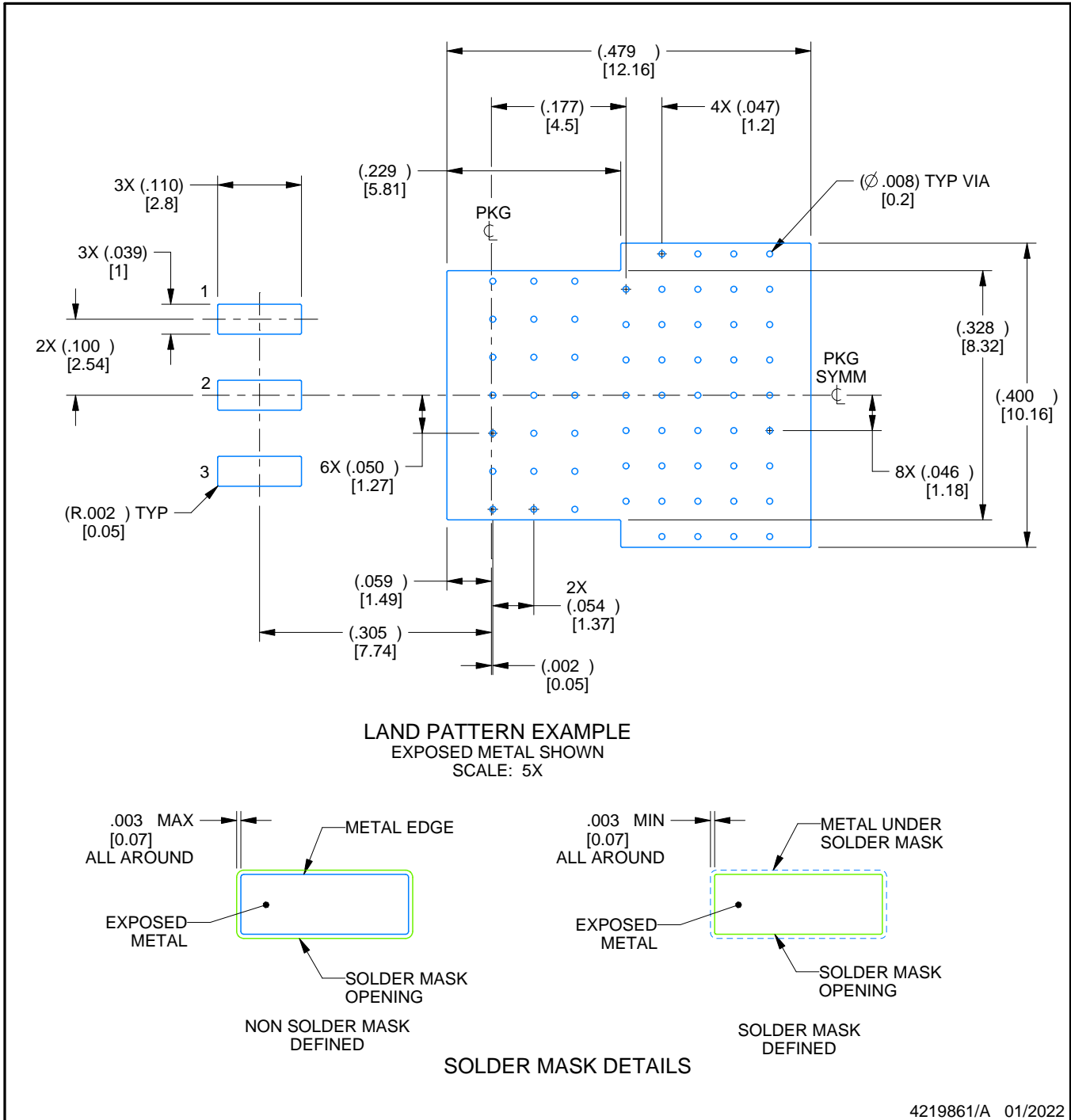

NOTES: (continued)

3. This package is designed to be soldered to a thermal pad on the board. For more information, see Texas Instruments literature numbers SLMA002(www.ti.com/lit/slm002) and SLMA004 (www.ti.com/lit/slma004).
4. Vias are optional depending on application, refer to device data sheet. It is recommended that vias under paste be filled, plugged or tented.

IMPORTANT NOTICE AND DISCLAIMER

TI PROVIDES TECHNICAL AND RELIABILITY DATA (INCLUDING DATASHEETS), DESIGN RESOURCES (INCLUDING REFERENCE DESIGNS), APPLICATION OR OTHER DESIGN ADVICE, WEB TOOLS, SAFETY INFORMATION, AND OTHER RESOURCES "AS IS" AND WITH ALL FAULTS, AND DISCLAIMS ALL WARRANTIES, EXPRESS AND IMPLIED, INCLUDING WITHOUT LIMITATION ANY IMPLIED WARRANTIES OF MERCHANTABILITY, FITNESS FOR A PARTICULAR PURPOSE OR NON-INFRINGEMENT OF THIRD PARTY INTELLECTUAL PROPERTY RIGHTS.

These resources are intended for skilled developers designing with TI products. You are solely responsible for (1) selecting the appropriate TI products for your application, (2) designing, validating and testing your application, and (3) ensuring your application meets applicable standards, and any other safety, security, regulatory or other requirements.

These resources are subject to change without notice. TI grants you permission to use these resources only for development of an application that uses the TI products described in the resource. Other reproduction and display of these resources is prohibited. No license is granted to any other TI intellectual property right or to any third party intellectual property right. TI disclaims responsibility for, and you fully indemnify TI and its representatives against any claims, damages, costs, losses, and liabilities arising out of your use of these resources.

TI's products are provided subject to [TI's Terms of Sale](#), [TI's General Quality Guidelines](#), or other applicable terms available either on ti.com or provided in conjunction with such TI products. TI's provision of these resources does not expand or otherwise alter TI's applicable warranties or warranty disclaimers for TI products. Unless TI explicitly designates a product as custom or customer-specified, TI products are standard, catalog, general purpose devices.

TI objects to and rejects any additional or different terms you may propose.

Copyright © 2026, Texas Instruments Incorporated

Last updated 10/2025