

LMP91000 Sensor AFE System: Configurable AFE Potentiostat for Low-Power Chemical-Sensing Applications

1 Features

- Typical Values, $T_A = 25^\circ\text{C}$
- Supply Voltage 2.7 V to 5.25 V
- Supply Current (Average Over Time) $<10\ \mu\text{A}$
- Cell Conditioning Current Up to 10 mA
- Reference Electrode Bias Current (85°C) 900pA (max)
- Output Drive Current 750 μA
- Complete Potentiostat Circuit-to-Interface to Most Chemical Cells
- Programmable Cell Bias Voltage
- Low-Bias Voltage Drift
- Programmable TIA gain 2.75 k Ω to 350 k Ω
- Sink and Source Capability
- I²C Compatible Digital Interface
- Ambient Operating Temperature -40°C to 85°C
- Package 14-Pin WSON
- Supported by WEBENCH[®] Sensor AFE Designer

2 Applications

- Chemical Species Identification
- Amperometric Applications
- Electrochemical Blood Glucose Meter

3 Description

The LMP91000 is a programmable analog front-end (AFE) for use in micro-power electrochemical sensing applications. It provides a complete signal path solution between a sensor and a microcontroller that generates an output voltage proportional to the cell current. The LMP91000's programmability enables it to support multiple electrochemical sensors such as 3-lead toxic gas sensors and 2-lead galvanic cell sensors with a single design as opposed to the multiple discrete solutions. The LMP91000 supports gas sensitivities over a range of 0.5 nA/ppm to 9500 nA/ppm. It also allows for an easy conversion of current ranges from 5 μA to 750 μA full scale.

The LMP91000's adjustable cell bias and transimpedance amplifier (TIA) gain are programmable through the I²C interface. The I²C interface can also be used for sensor diagnostics. An integrated temperature sensor can be read by the user through the VOUT pin and used to provide additional signal correction in the μC or monitored to verify temperature conditions at the sensor.

The LMP91000 is optimized for micro-power applications and operates over a voltage range of 2.7 to 5.25 V. The total current consumption can be less than 10 μA . Further power savings are possible by switching off the TIA amplifier and shorting the reference electrode to the working electrode with an internal switch.

Device Information⁽¹⁾

PART NUMBER	PACKAGE	BODY SIZE (NOM)
LMP91000	WSON (14)	4.00 mm x 4.00 mm

(1) For all available packages, see the orderable addendum at the end of the datasheet.

Simplified Application Schematic

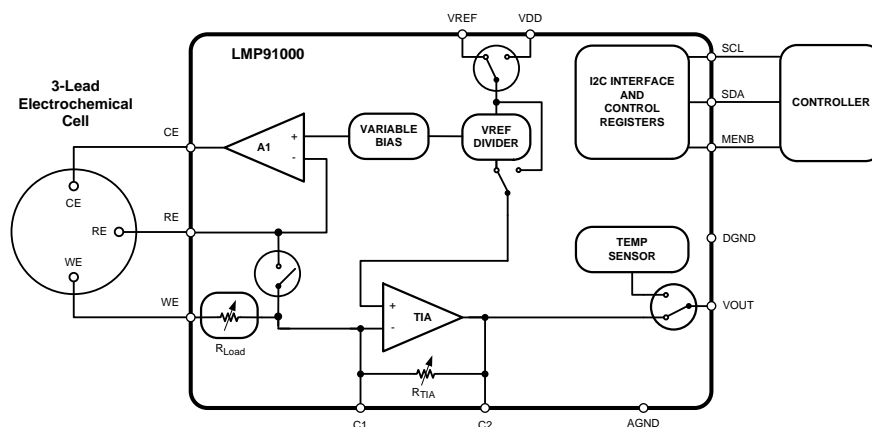

Table of Contents

1 Features	1	7.3 Feature Description	13
2 Applications	1	7.4 Device Functional Modes	19
3 Description	1	7.5 Programming	20
4 Revision History	2	7.6 Registers Maps	21
5 Pin Configuration and Functions	3	8 Application and Implementation	24
6 Specifications	4	8.1 Application Information	24
6.1 Absolute Maximum Ratings	4	8.2 Typical Application	26
6.2 ESD Ratings	4	9 Power Supply Recommendations	28
6.3 Recommended Operating Conditions	4	9.1 Power Consumption	28
6.4 Thermal Information	4	10 Layout	29
6.5 Electrical Characteristics	5	10.1 Layout Guidelines	29
6.6 I ² C Interface	7	10.2 Layout Example	29
6.7 Timing Requirements	8	11 Device and Documentation Support	30
6.8 Typical Characteristics	9	11.1 Trademarks	30
7 Detailed Description	13	11.2 Electrostatic Discharge Caution	30
7.1 Overview	13	11.3 Glossary	30
7.2 Functional Block Diagram	13	12 Mechanical, Packaging, and Orderable Information	30

4 Revision History

Changes from Revision H (March 2013) to Revision I	Page
<ul style="list-style-type: none"> Added <i>ESD Ratings table</i>, <i>Feature Description section</i>, <i>Device Functional Modes</i>, <i>Application and Implementation section</i>, <i>Power Supply Recommendations section</i>, <i>Layout section</i>, <i>Device and Documentation Support section</i>, and <i>Mechanical, Packaging, and Orderable Information section</i> 	3

Changes from Revision G (March 2013) to Revision H	Page
<ul style="list-style-type: none"> Changed layout of National Data Sheet to TI format 	27

5 Pin Configuration and Functions

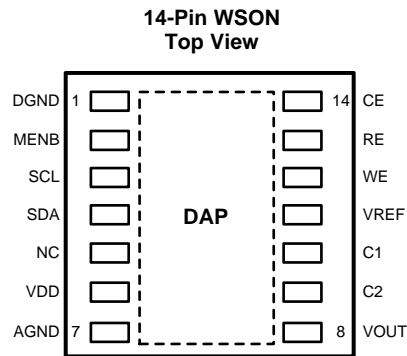

Pin Functions

PIN		I/O	DESCRIPTION
NAME	NO.		
DGND	1	G	Connect to ground
MENB	2	I	Module Enable, Active-Low
SCL	3	I	Clock signal for I ² C compatible interface
SDA	4	I/O	Data for I ² C compatible interface
NC	5	N/A	Not Internally Connected
VDD	6	P	Supply Voltage
AGND	7	G	Ground
VOUT	8	O	Analog Output
C2	9	N/A	External filter connector (Filter between C1 and C2)
C1	10	N/A	External filter connector (Filter between C1 and C2)
VREF	11	I	Voltage Reference input
WE	12	I	Working Electrode. Output to drive the Working Electrode of the chemical sensor
RE	13	I	Reference Electrode. Input to drive Counter Electrode of the chemical sensor
CE	14	I	Counter Electrode. Output to drive Counter Electrode of the chemical sensor
DAP	—	N/C	Connect to AGND

6 Specifications

6.1 Absolute Maximum Ratings

over operating free-air temperature (unless otherwise noted) ⁽¹⁾

	MIN	MAX	UNIT
Voltage between any two pins		6.0	V
Current through VDD or VSS		50	mA
Current sunk and sourced by CE pin		10	mA
Current out of other pins ⁽²⁾		5	mA
Junction Temperature ⁽³⁾		150	°C
Storage temperature	–65	150	°C

- (1) Stresses beyond those listed under *Absolute Maximum Ratings* may cause permanent damage to the device. These are stress ratings only, which do not imply functional operation of the device at these or any other conditions beyond those indicated under *Recommended Operating Conditions*. Exposure to absolute-maximum-rated conditions for extended periods may affect device reliability.
- (2) All non-power pins of this device are protected against ESD by snapback devices. Voltage at such pins will rise beyond absmax if current is forced into pin.
- (3) The maximum power dissipation is a function of $T_{J(MAX)}$, $R_{\theta JA}$, and the ambient temperature, T_A . The maximum allowable power dissipation at any ambient temperature is $P_{DMAX} = (T_{J(MAX)} - T_A) / \theta_{JA}$. All numbers apply for packages soldered directly onto a PCB.

6.2 ESD Ratings

		VALUE	UNIT
$V_{(ESD)}$ Electrostatic discharge	Human-body model (HBM), per ANSI/ESDA/JEDEC JS-001 ⁽¹⁾	±2000	V
	Charged-device model (CDM), per JEDEC specification JESD22-C101 ⁽²⁾	±1000	

- (1) JEDEC document JEP155 states that 500-V HBM allows safe manufacturing with a standard ESD control process.
- (2) JEDEC document JEP157 states that 250-V CDM allows safe manufacturing with a standard ESD control process.

6.3 Recommended Operating Conditions

	MIX	MAX	UNIT
Supply Voltage $V_S = (VDD - AGND)$	2.7	5.25	V
Temperature Range ⁽¹⁾	–40	85	°C

- (1) The maximum power dissipation is a function of $T_{J(MAX)}$, $R_{\theta JA}$, and the ambient temperature, T_A . The maximum allowable power dissipation at any ambient temperature is $P_{DMAX} = (T_{J(MAX)} - T_A) / \theta_{JA}$. All numbers apply for packages soldered directly onto a PCB.

6.4 Thermal Information

THERMAL METRIC ⁽¹⁾		LMP91000	UNIT
		WSON	
		14 PINS	
$R_{\theta JA}$	Package Thermal Resistance	44	°C/W

- (1) For more information about traditional and new thermal metrics, see the *IC Package Thermal Metrics* application report, [SPRA953](http://www.ti.com/lit/zip/Spra953).

6.5 Electrical Characteristics

Unless otherwise specified, $T_A = 25^\circ\text{C}$, $V_S = (V_{DD} - \text{AGND})$, $V_S = 3.3\text{ V}$ and $\text{AGND} = \text{DGND} = 0\text{ V}$, $V_{REF} = 2.5\text{ V}$, Internal Zero = 20% V_{REF} .⁽¹⁾

PARAMETER		TEST CONDITIONS	MIN ⁽²⁾	TYP ⁽³⁾	MAX ⁽²⁾	UNIT
POWER SUPPLY SPECIFICATION						
I_S	Supply Current	3-lead amperometric cell mode MODECN = 0x03		10	13.5	μA
		–40 to 80°C (please verify that the degree is correct)			15	
		Standby mode MODECN = 0x02		6.5	8	
		–40 to 80°C			10	
		Temperature Measurement mode with TIA OFF MODECN = 0x06		11.4	13.5	
		–40 to 80°C			15	
		Temperature Measurement mode with TIA ON MODECN = 0x07		14.9	18	
		–40 to 80°C			20	
		2-lead ground-referred galvanic cell mode VREF=1.5 V MODECN = 0x01		6.2	8	
		–40 to 80°C			9	
		Deep Sleep mode MODECN = 0x00		0.6	0.85	
		–40 to 80°C			1	
POTENTIOSTAT						
Bias_RW	Bias Programming range (differential voltage between RE pin and WE pin)	Percentage of voltage referred to VREF or VDD		$\pm 24\%$		
	Bias Programming Resolution	First two smallest step		± 1		
		All other steps		$\pm 2\%$		
I_{RE}	Input bias current at RE pin	VDD = 2.7 V				pA
		Internal Zero 50% VDD		–90	90	
		–40 to 80°C		–800	800	
		VDD = 5.25 V				
		Internal Zero 50% VDD		–90	90	
		–40 to 80°C		–900	900	
I_{CE}	Minimum operating current capability	sink		750		μA
		source		750		
	Minimum charging capability ⁽⁴⁾	sink		10		mA
		source		10		
AOL_A1	Open-loop voltage gain of control loop op amp (A1)	$300\text{ mV} \leq V_{CE} \leq V_S - 300\text{ mV}$;				dB
		$-750\ \mu\text{A} \leq I_{CE} \leq 750\ \mu\text{A}$				
		–40 to 80°C		104	120	

- (1) Electrical Table values apply only for factory testing conditions at the temperature indicated. Factory testing conditions result in very limited self-heating of the device such that $T_J = T_A$.
- (2) Limits are 100% production tested at 25°C. Limits over the operating temperature range are specified through correlations using statistical quality control (SQC) method.
- (3) Typical values represent the most likely parametric norm as determined at the time of characterization. Actual typical values may vary over time and will also depend on the application and configuration. The typical values are not tested and are not specified on shipped production material.
- (4) At such currents no accuracy of the output voltage can be expected.

Electrical Characteristics (continued)

Unless otherwise specified, $T_A = 25^\circ\text{C}$, $V_S = (V_{DD} - \text{AGND})$, $V_S = 3.3\text{ V}$ and $\text{AGND} = \text{DGND} = 0\text{ V}$, $V_{REF} = 2.5\text{ V}$, Internal Zero = 20% V_{REF} .⁽¹⁾

PARAMETER		TEST CONDITIONS	MIN ⁽²⁾	TYP ⁽³⁾	MAX ⁽²⁾	UNIT
en_RW	Low Frequency integrated noise between RE pin and WE pin	0.1 Hz to 10 Hz, Zero Bias (5)		3.4		μVpp
		0.1 Hz to 10 Hz, with Bias (5) (6)		5.1		
V _{OS_RW}	WE Voltage Offset referred to RE	BIAS polarity (7) –40 to 80°C	0% VREF Internal Zero=20% VREF	–550	550	μV
			0% VREF Internal Zero=50% VREF			
			0% VREF Internal Zero=67% VREF			
			±1% VREF	–575	575	
			±2% VREF	–610	610	
			±4% VREF	–750	750	
			±6% VREF	–840	840	
			±8% VREF	–930	930	
			±10% VREF	–1090	1090	
			±12% VREF	–1235	1235	
			±14% VREF	–1430	1430	
			±16% VREF	–1510	1510	
			±18% VREF	–1575	1575	
			±20% VREF	–1650	1650	
TcV _{OS_RW}	WE Voltage Offset Drift referred to RE from –40°C to 85°C (8)	BIAS polarity (7)	0% VREF Internal Zero=20% VREF	–4	4	$\mu\text{V}/^\circ\text{C}$
			0% VREF Internal Zero=50% VREF			
			0% VREF Internal Zero=67% VREF			
			±1% VREF	–4	4	
			±2% VREF	–4	4	
			±4% VREF	–5	5	
			±6% VREF	–5	5	
			±8% VREF	–5	5	
			±10% VREF	–6	6	
			±12% VREF	–6	6	
			±14% VREF	–7	7	
			±16% VREF	–7	7	
			±18% VREF	–8	8	
			±20% VREF	–8	8	
±22% VREF	–8	8				
±24% VREF	–8	8				

(5) This parameter includes both A1 and TIA's noise contribution.

(6) In case of external reference connected, the noise of the reference has to be added.

(7) For negative bias polarity the Internal Zero is set at 67% VREF.

(8) Offset voltage temperature drift is determined by dividing the change in VOS at the temperature extremes by the total temperature change. Starting from the measured voltage offset at temperature T1 ($V_{OS_RW}(T1)$), the voltage offset at temperature T2 ($V_{OS_RW}(T2)$) is calculated according the following formula: $V_{OS_RW}(T2) = V_{OS_RW}(T1) + \text{ABS}(T2 - T1) * TcV_{OS_RW}$.

Electrical Characteristics (continued)

Unless otherwise specified, $T_A = 25^\circ\text{C}$, $V_S = (V_{DD} - \text{AGND})$, $V_S = 3.3\text{ V}$ and $\text{AGND} = \text{DGND} = 0\text{ V}$, $V_{REF} = 2.5\text{ V}$, Internal Zero = 20% V_{REF} .⁽¹⁾

PARAMETER		TEST CONDITIONS	MIN ⁽²⁾	TYP ⁽³⁾	MAX ⁽²⁾	UNIT
TIA_GAIN	Transimpedance gain accuracy			5%		
	Linearity			±0.05%		
	Programmable TIA Gains	7 programmable gain resistors		2.75		kΩ
				3.5		
				7		
			14			
			35			
			120			
			350			
	Maximum external gain resistor		350			
TIA_ZV	Internal zero voltage	3 programmable percentages of V_{REF}		20%		
				50%		
		67%				
		3 programmable percentages of V_{DD}		20%		
				50%		
				67%		
	Internal zero voltage Accuracy			±0.04%		
RL	Programmable Load	4 programmable resistive loads		10		Ω
				33		
			50			
				100		
	Load accuracy			5%		
PSRR	Power Supply Rejection Ratio at RE pin	2.7 V ≤ V_{DD} ≤ 5.25 V	Internal zero 20% V_{REF}	80	110	dB
			Internal zero 50% V_{REF}			
			Internal zero 67% V_{REF}			
TEMPERATURE SENSOR SPECIFICATION (Refer to Table 1 in the Feature Description for details)						
	Temperature Error	$T_A = -40^\circ\text{C}$ to 85°C		-3	3	°C
	Sensitivity	$T_A = -40^\circ\text{C}$ to 85°C		-8.2		mV/°C
	Power on time				1.9	ms
EXTERNAL REFERENCE SPECIFICATION						
VREF	External Voltage reference range		1.5		V_{DD}	V
	Input impedance			10		MΩ

6.6 I²C Interface

Unless otherwise specified, $T_A = 25^\circ\text{C}$, $V_S = (V_{DD} - \text{AGND})$, $2.7\text{ V} < V_S < 5.25\text{ V}$ and $\text{AGND} = \text{DGND} = 0\text{ V}$, $V_{REF} = 2.5\text{ V}$.⁽¹⁾

PARAMETER		TEST CONDITIONS	MIN ⁽²⁾	TYP ⁽³⁾	MAX ⁽²⁾	UNIT
V_{IH}	Input High Voltage	-40 to 80°C	0.7* V_{DD}			V
V_{IL}	Input Low Voltage	-40 to 80°C			0.3* V_{DD}	V
V_{OL}	Output Low Voltage	$I_{OUT} = 3\text{ mA}$			0.4	V
	Hysteresis ⁽⁴⁾	-40 to 80°C	0.1* V_{DD}			V
C_{IN}	Input Capacitance on all digital pins	-40 to 80°C		0.5		pF

- (1) Electrical Table values apply only for factory testing conditions at the temperature indicated. Factory testing conditions result in very limited self-heating of the device such that $T_J = T_A$.
- (2) Limits are 100% production tested at 25°C . Limits over the operating temperature range are specified through correlations using statistical quality control (SQC) method.
- (3) Typical values represent the most likely parametric norm as determined at the time of characterization. Actual typical values may vary over time and will also depend on the application and configuration. The typical values are not tested and are not specified on shipped production material.
- (4) This parameter is specified by design or characterization.

6.7 Timing Requirements

Unless otherwise specified, $T_A = 25^\circ\text{C}$, $V_S = (V_{DD} - \text{AGND})$, $V_S = 3.3\text{ V}$ and $\text{AGND} = \text{DGND} = 0\text{ V}$, $V_{REF} = 2.5\text{ V}$, Internal Zero = 20% V_{REF} .⁽¹⁾

			MIN	TYP	MAX	UNIT
f_{SCL}	Clock Frequency	-40 to 80°C	10		100	kHz
t_{LOW}	Clock Low Time	-40 to 80°C	4.7			μs
t_{HIGH}	Clock High Time	-40 to 80°C	4.0			μs
$t_{\text{HD;STA}}$	Data valid	After this period, the first clock pulse is generated	4.0			μs
$t_{\text{SU;STA}}$	Set-up time for a repeated START condition	-40 to 80°C	4.7			μs
$t_{\text{HD;DAT}}$	Data hold time ⁽²⁾	-40 to 80°C	0			ns
$t_{\text{SU;DAT}}$	Data Set-up time	-40 to 80°C	250			ns
t_f	SDA fall time ⁽³⁾	$I_L \leq 3\text{ mA}$; $C_L \leq 400\text{ pF}$ -40 to 80°C			250	ns
$t_{\text{SU;STO}}$	Set-up time for STOP condition	-40 to 80°C	4.0			μs
t_{BUF}	Bus free time between a STOP and START condition	-40 to 80°C	4.7			μs
$t_{\text{VD;DAT}}$	Data valid time	-40 to 80°C			3.45	μs
$t_{\text{VD;ACK}}$	Data valid acknowledge time	-40 to 80°C			3.45	μs
t_{SP}	Pulse width of spikes that must be suppressed by the input filter ⁽³⁾	-40 to 80°C			50	ns
t_{timeout}	SCL and SDA Timeout	-40 to 80°C	25		100	ms
$t_{\text{EN;START}}$	I ² C Interface Enabling	-40 to 80°C	600			ns
$t_{\text{EN;STOP}}$	I ² C Interface Disabling	-40 to 80°C	600			ns
$t_{\text{EN;HIGH}}$	Time between consecutive I ² C interface enabling and disabling	-40 to 80°C	600			ns

- (1) Electrical Table values apply only for factory testing conditions at the temperature indicated. Factory testing conditions result in very limited self-heating of the device such that $T_J = T_A$.
- (2) LMP91000 provides an internal 300-ns minimum hold time to bridge the undefined region of the falling edge of SCL.
- (3) This parameter is specified by design or characterization.

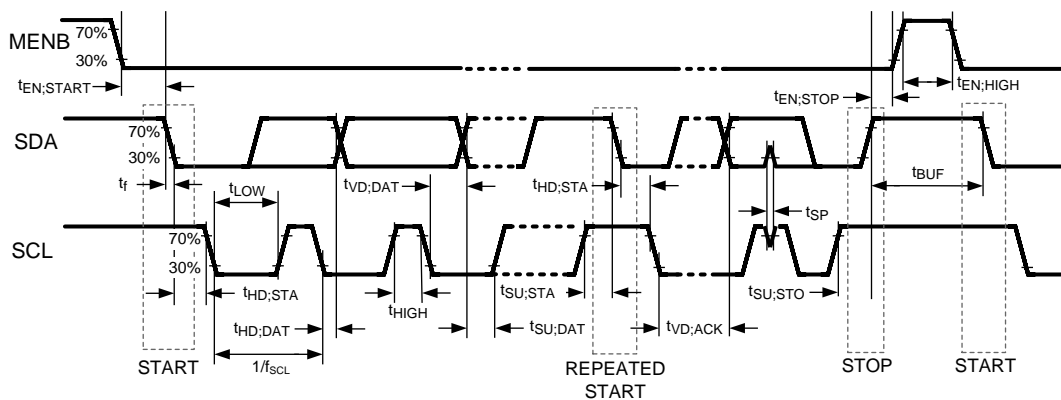

Figure 1. Timing Diagram

6.8 Typical Characteristics

Unless otherwise specified, $T_A = 25^\circ\text{C}$, $V_{S} = (V_{DD} - \text{AGND})$, $2.7\text{V} < V_{S} < 5.25\text{V}$ and $\text{AGND} = \text{DGND} = 0\text{V}$, $V_{\text{REF}} = 2.5\text{V}$.

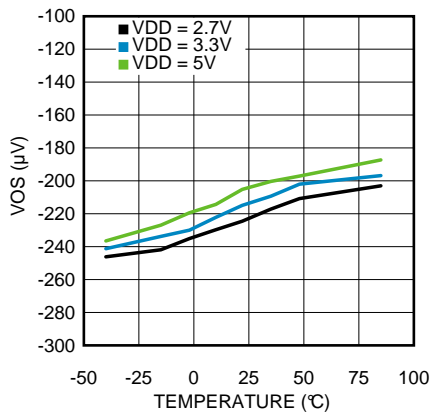

Figure 2. Input $V_{\text{OS_RW}}$ vs. Temperature (Vbias 0 mV)

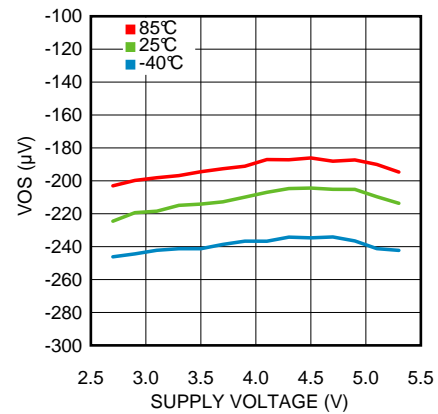

Figure 3. Input $V_{\text{OS_RW}}$ vs. VDD (Vbias 0 mV)

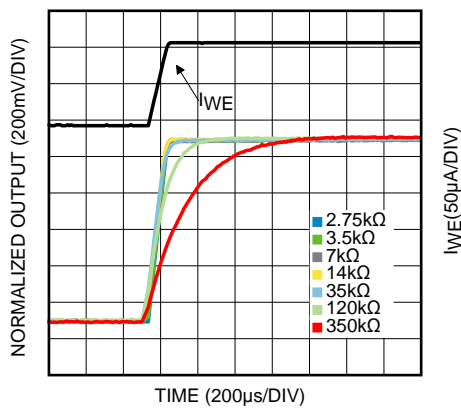

Figure 4. I_{WE} Step Current Response (Rise)

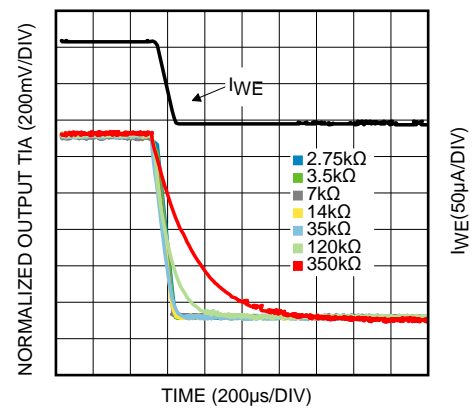

Figure 5. I_{WE} Step Current Response (Fall)

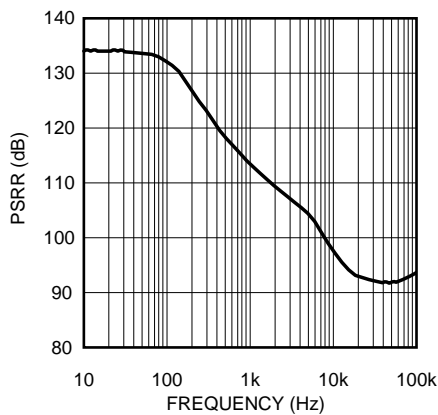

Figure 6. AC PSRR vs. Frequency

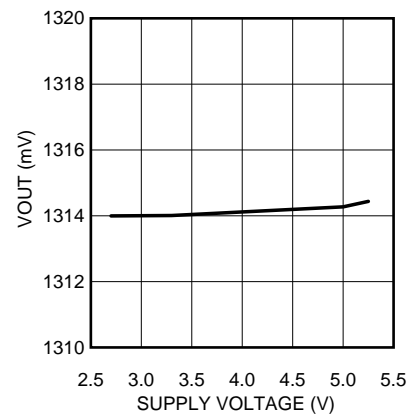

Figure 7. Temperature Sensor Output vs. VDD (Temperature = 30°C)

Typical Characteristics (continued)

Unless otherwise specified, $T_A = 25^\circ\text{C}$, $V_S = (V_{DD} - \text{AGND})$, $2.7\text{V} < V_S < 5.25\text{V}$ and $\text{AGND} = \text{DGND} = 0\text{V}$, $V_{\text{REF}} = 2.5\text{V}$.

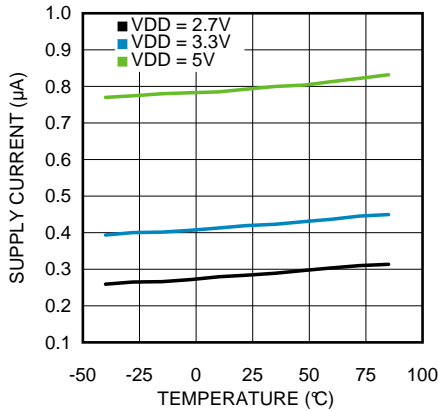

Figure 8. Supply Current vs. Temperature (Deep Sleep Mode)

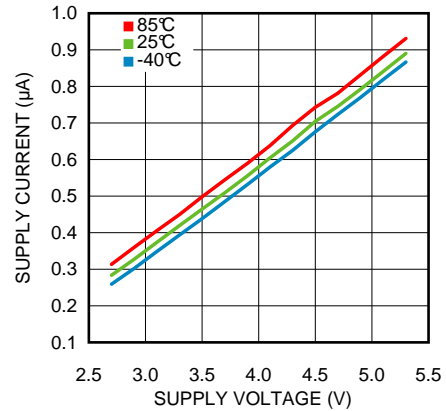

Figure 9. Supply Current vs. VDD (Deep Sleep Mode)

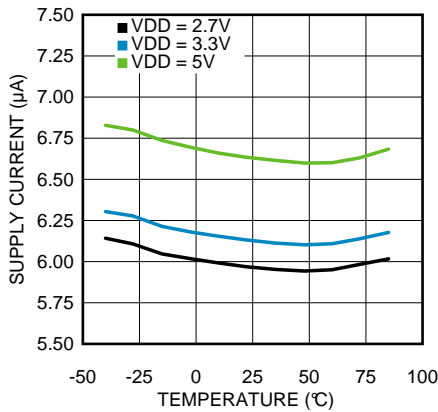

Figure 10. Supply Current vs. Temperature (Standby Mode)

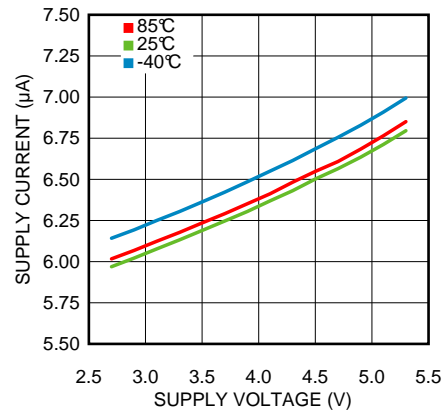

Figure 11. Supply Current vs. VDD (Standby Mode)

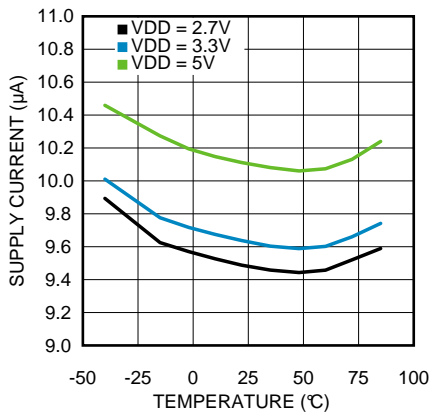

Figure 12. Supply Current vs. Temperature (3-Lead Amperometric Mode)

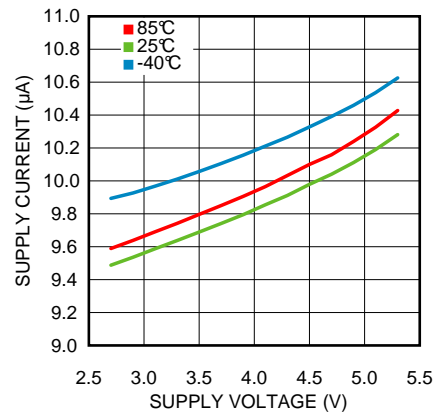

Figure 13. Supply Current vs. VDD (3-Lead Amperometric Mode)

Typical Characteristics (continued)

Unless otherwise specified, $T_A = 25^\circ\text{C}$, $V_S = (V_{DD} - \text{AGND})$, $2.7\text{V} < V_S < 5.25\text{V}$ and $\text{AGND} = \text{DGND} = 0\text{V}$, $V_{\text{REF}} = 2.5\text{V}$.

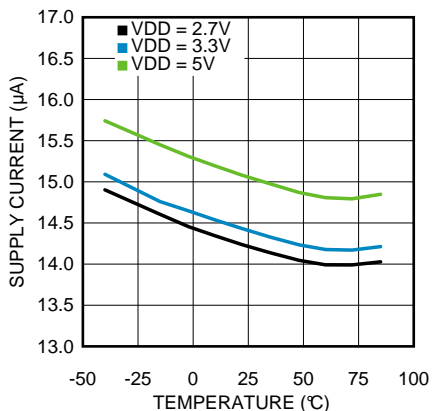

Figure 14. Supply Current vs. Temperature (Temp Measurement TIA On)

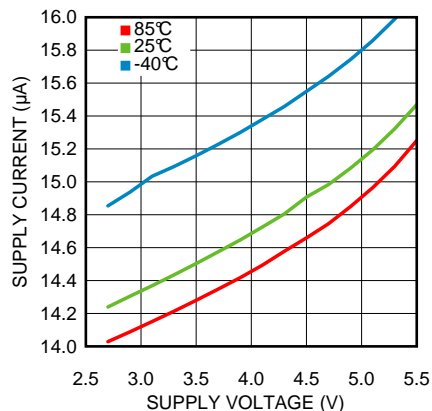

Figure 15. Supply Current vs. VDD (Temp Measurement TIA On)

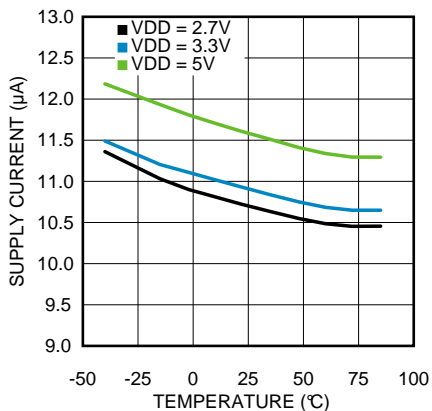

Figure 16. Supply Current vs. Temperature (Temp Measurement TIA Off)

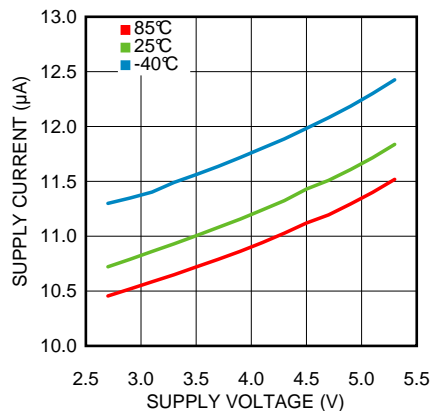

Figure 17. Supply Current vs. VDD (Temp Measurement TIA Off)

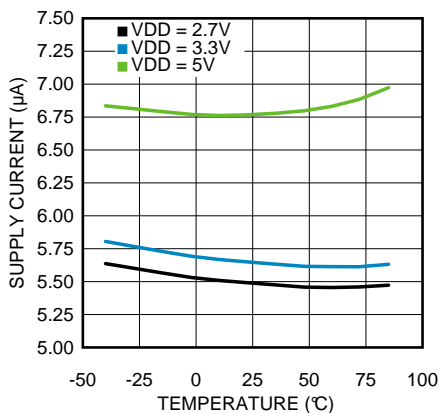

Figure 18. Supply Current vs. Temperature (2-Lead Ground-Referred Amperometric Mode)

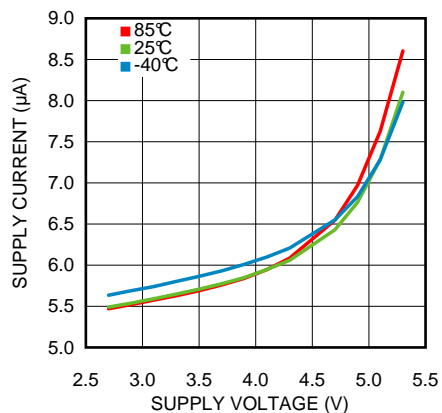

Figure 19. Supply Current vs. VDD (2-Lead Ground-Referred Amperometric Mode)

Typical Characteristics (continued)

Unless otherwise specified, $T_A = 25^\circ\text{C}$, $V_S = (V_{DD} - \text{AGND})$, $2.7\text{V} < V_S < 5.25\text{V}$ and $\text{AGND} = \text{DGND} = 0\text{V}$, $V_{REF} = 2.5\text{V}$.

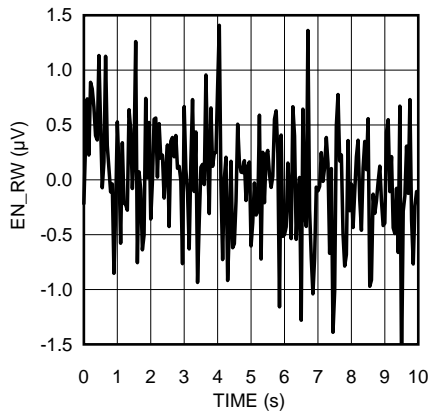

Figure 20. 0.1-Hz to 10-Hz Noise, 0-V Bias

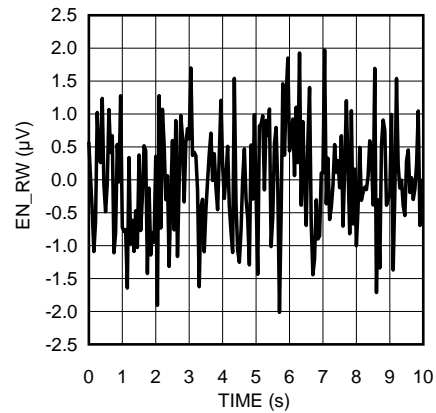

Figure 21. 0.1-Hz to 10-Hz Noise, 300-mV Bias

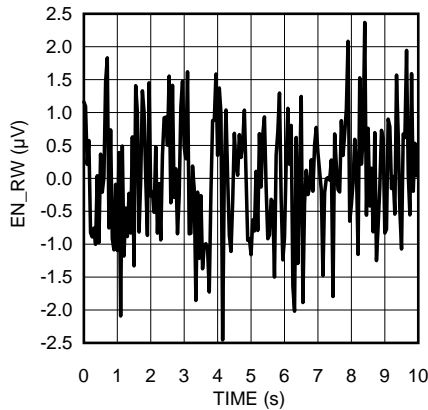

Figure 22. 0.1-Hz to 10-Hz Noise, 600-mV Bias

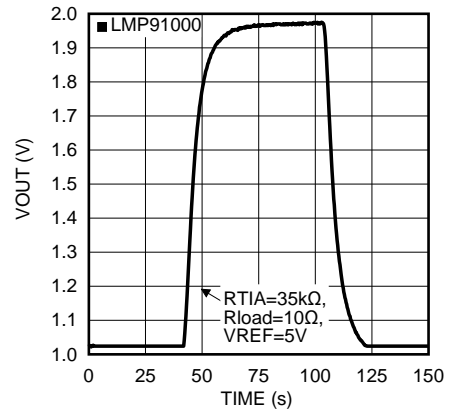

Figure 23. A VOUT Step Response 100-PPM to 400-PPM CO (CO Gas Sensor Connected to LMP91000)

7 Detailed Description

7.1 Overview

The LMP91000 is a programmable AFE for use in micropower chemical sensing applications. The LMP91000 is designed for 3-lead single gas sensors and for 2-lead galvanic cell sensors. This device provides all of the functionality for detecting changes in gas concentration based on a delta current at the working electrode. The LMP91000 generates an output voltage proportional to the cell current. Transimpedance gain is user programmable through an I²C compatible interface from 2.75 k Ω to 350 k Ω making it easy to convert current ranges from 5 μ A to 750 μ A full scale. Optimized for micro-power applications, the LMP91000 AFE works over a voltage range of 2.7 V to 5.25 V. The cell voltage is user selectable using the on board programmability. In addition, it is possible to connect an external transimpedance gain resistor. A temperature sensor is embedded and it can be power cycled through the interface. The output of this temperature sensor can be read by the user through the VOUT pin. It is also possible to have both temperature output and output of the TIA at the same time; the pin C2 is internally connected to the output of the transimpedance (TIA), while the temperature is available at the VOUT pin. Depending on the configuration, total current consumption for the device can be less than 10 μ A. For power savings, the transimpedance amplifier can be turned off and instead a load impedance equivalent to the TIA's inputs impedance is switched in.

7.2 Functional Block Diagram

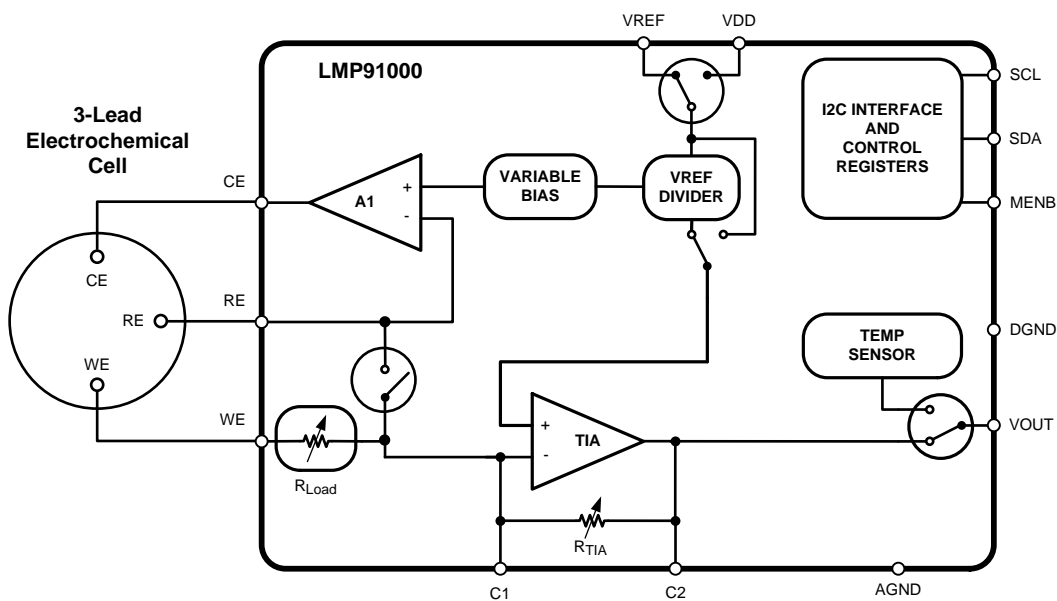

7.3 Feature Description

7.3.1 Potentiostat Circuitry

The core of the LMP91000 is a potentiostat circuit. It consists of a differential input amplifier used to compare the potential between the working and reference electrodes to a required working bias potential (set by the **Variable Bias circuitry**). The error signal is amplified and applied to the counter electrode (through the **Control Amplifier - A1**). Any changes in the impedance between the working and reference electrodes will cause a change in the voltage applied to the counter electrode, in order to maintain the constant voltage between working and reference electrodes. A **Transimpedance Amplifier** connected to the working electrode, is used to provide an output voltage that is proportional to the cell current. The working electrode is held at virtual ground (**Internal ground**) by the transimpedance amplifier. The potentiostat will compare the reference voltage to the desired bias potential and adjust the voltage at the counter electrode to maintain the proper working-to-reference voltage.

Feature Description (continued)

7.3.1.1 Transimpedance Amplifier

The transimpedance amplifier (TIA) has 7 programmable internal gain resistors. This accommodates the full scale ranges of most existing sensors. Moreover an external gain resistor can be connected to the LMP91000 between C1 and C2 pins. The gain is set through the I²C interface.

7.3.1.2 Control Amplifier

The control amplifier (A1 op amp) has two tasks: a) providing initial charge to the sensor, b) providing a bias voltage to the sensor. A1 has the capability to drive up to 10 mA into the sensor in order to provide a fast initial conditioning. A1 is able to sink and source current according to the connected gas sensor (reducing or oxidizing gas sensor). It can be powered down to reduce system power consumption. However powering down A1 is not recommended, as it may take a long time for the sensor to recover from this situation.

7.3.1.3 Variable Bias

The Variable Bias block circuitry provides the amount of bias voltage required by a biased gas sensor between its reference and working electrodes. The bias voltage can be programmed to be 1% to 24% (14 steps in total) of the supply, or of the external reference voltage. The 14 steps can be programmed through the I²C interface. The polarity of the bias can be also programmed.

7.3.1.4 Internal Zero

The internal Zero is the voltage at the non-inverting pin of the TIA. The internal zero can be programmed to be either 67%, 50% or 20%, of the supply, or the external reference voltage. This provides both sufficient headroom for the counter electrode of the sensor to swing, in case of sudden changes in the gas concentration, and best use of the ADC's full scale input range.

The Internal zero is provided through an internal voltage divider. The divider is programmed through the I²C interface.

7.3.1.5 Temperature Sensor

The embedded temperature sensor can be switched off during gas concentration measurement to save power. The temperature measurement is triggered through the I²C interface. The temperature output is available at the VOUT pin until the configuration bit is reset. The output signal of the temperature sensor is a voltage, referred to the ground of the LMP91000 (AGND).

Table 1. Temperature Sensor Transfer

TEMPERATURE (°C)	OUTPUT VOLTAGE (mV)	TEMPERATURE (°C)	OUTPUT VOLTAGE (mV)
-40	1875	23	1375
-39	1867	24	1367
-38	1860	25	1359
-37	1852	26	1351
-36	1844	27	1342
-35	1836	28	1334
-34	1828	29	1326
-33	1821	30	1318
-32	1813	31	1310
-31	1805	32	1302
-30	1797	33	1293
-29	1789	34	1285
-28	1782	35	1277
-27	1774	36	1269
-26	1766	37	1261
-25	1758	38	1253

Feature Description (continued)
Table 1. Temperature Sensor Transfer (continued)

TEMPERATURE (°C)	OUTPUT VOLTAGE (mV)	TEMPERATURE (°C)	OUTPUT VOLTAGE (mV)
-24	1750	39	1244
-23	1742	40	1236
-22	1734	41	1228
-21	1727	42	1220
-20	1719	43	1212
-19	1711	44	1203
-18	1703	45	1195
-17	1695	46	1187
-16	1687	47	1179
-15	1679	48	1170
-14	1671	49	1162
-13	1663	50	1154
-12	1656	51	1146
-11	1648	52	1137
-10	1640	53	1129
-9	1632	54	1121
-8	1624	55	1112
-7	1616	56	1104
-6	1608	57	1096
-5	1600	58	1087
-4	1592	59	1079
-3	1584	60	1071
-2	1576	61	1063
-1	1568	62	1054
0	1560	63	1046
1	1552	64	1038
2	1544	65	1029
3	1536	66	1021
4	1528	67	1012
5	1520	68	1004
6	1512	69	996
7	1504	70	987
8	1496	71	979
9	1488	72	971
10	1480	73	962
11	1472	74	954
12	1464	75	945
13	1456	76	937
14	1448	77	929
15	1440	78	920
16	1432	79	912
17	1424	80	903
18	1415	81	895
19	1407	82	886
20	1399	83	878

Feature Description (continued)
Table 1. Temperature Sensor Transfer (continued)

TEMPERATURE (°C)	OUTPUT VOLTAGE (mV)	TEMPERATURE (°C)	OUTPUT VOLTAGE (mV)
21	1391	84	870
22	1383	85	861

Although the temperature sensor is very linear, its response does have a slight downward parabolic shape. This shape is very accurately reflected in [Table 1](#). For a linear approximation, a line can easily be calculated over the desired temperature range from [Table 1](#) using the two-point equation:

$$V - V_1 = ((V_2 - V_1) / (T_2 - T_1)) * (T - T_1)$$

where

- V is in mV, T is in °C, T₁ and V₁ are the coordinates of the lowest temperature
- T₂ and V₂ are the coordinates of the highest temperature. (1)

For example, to determine the equation of a line over a temperature range of 20°C to 50°C, proceed as follows:

$$V - 1399 \text{ mV} = ((1154 \text{ mV} - 1399 \text{ mV}) / (50^\circ\text{C} - 20^\circ\text{C})) * (T - 20^\circ\text{C}) \quad (2)$$

$$V - 1399 \text{ mV} = -8.16 \text{ mV}/^\circ\text{C} * (T - 20^\circ\text{C}) \quad (3)$$

$$V = (-8.16 \text{ mV}/^\circ\text{C}) * T + 1562.2 \text{ mV} \quad (4)$$

Using this method of linear approximation, the transfer function can be approximated for one or more temperature ranges of interest.

7.3.1.6 Gas Sensor Interface

The LMP91000 supports both 3-lead and 2-lead gas sensors. Most of the toxic gas sensors are amperometric cells with 3 leads (Counter, Worker and Reference). These leads should be connected to the LMP91000 in the potentiostat topology. The 2-lead gas sensor (known as galvanic cell) should be connected as simple buffer either referred to the ground of the system or referred to a reference voltage. The LMP91000 support both connections for 2-lead gas sensor.

7.3.1.6.1 3-Lead Amperometric Cell in Potentiostat Configuration

Most of the amperometric cell have 3 leads (Counter, Reference and Working electrodes). The interface of the 3-lead gas sensor to the LMP91000 is straightforward, the leads of the gas sensor need to be connected to the namesake pins of the LMP91000.

The LMP91000 is then configured in 3-lead amperometric cell mode; in this configuration the Control Amplifier (A1) is ON and provides the internal zero voltage and bias in case of biased gas sensor. The transimpedance amplifier (TIA) is ON, it converts the current generated by the gas sensor in a voltage, according to the transimpedance gain:

$$\text{Gain} = R_{TIA} \tag{5}$$

If different gains are required, an external resistor can be connected between the pins C1 and C2. In this case the internal feedback resistor should be programmed to “external”. The R_{Load} together with the output capacitance of the gas sensor acts as a low pass filter.

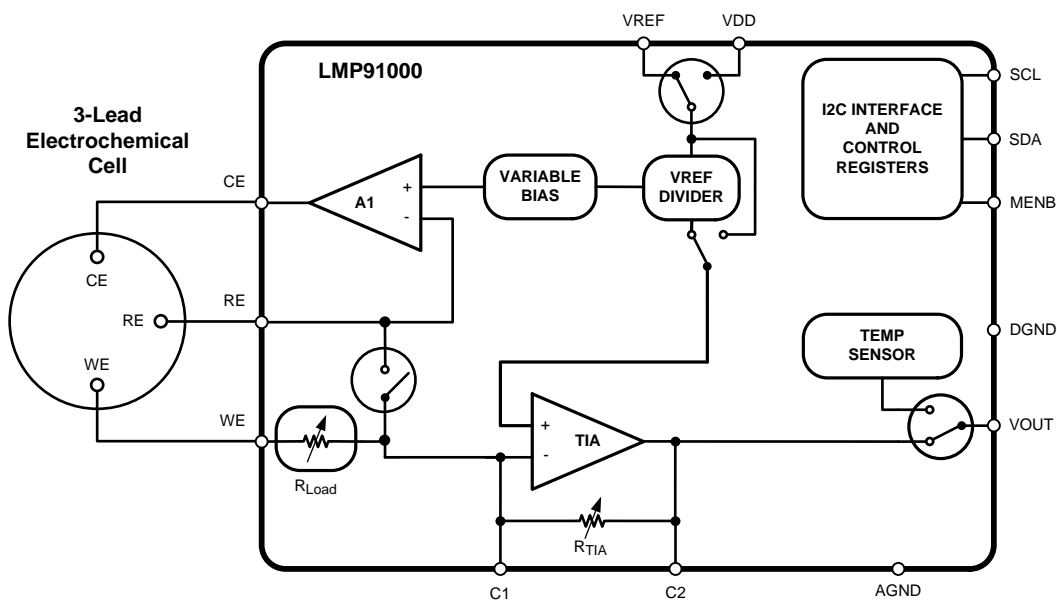

Figure 24. 3-Lead Amperometric Cell

7.3.1.6.2 2-Lead Galvanic Cell In Ground Referred Configuration

When the LMP91000 is interfaced to a galvanic cell (for instance to an Oxygen gas sensor) referred to the ground of the system, an external resistor needs to be placed in parallel to the gas sensor; the negative electrode of the gas sensor is connected to the ground of the system and the positive electrode to the Vref pin of the LMP91000, the working pin of the LMP91000 is connected to the ground.

The LMP91000 is then configured in 2-lead galvanic cell mode and the Vref bypass feature needs to be enabled. In this configuration the Control Amplifier (A1) is turned off, and the output of the gas sensor is amplified by the Transimpedance Amplifier (TIA) which is configured as a simple non-inverting amplifier.

The gain of this non inverting amplifier is set according the following formula:

$$\text{Gain} = 1 + (R_{TIA} / R_{Load}) \quad (6)$$

If different gains are required, an external resistor can be connected between the pins C1 and C2. In this case the internal feedback resistor should be programmed to “external”.

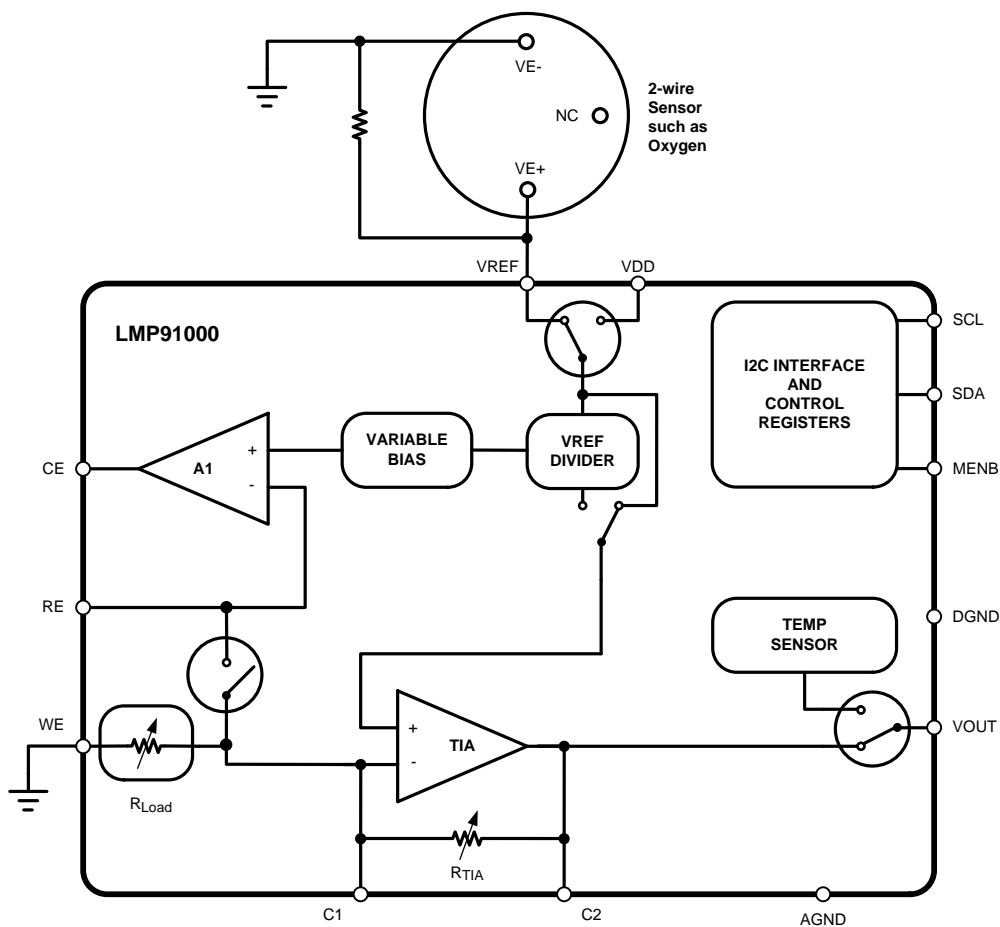

Figure 25. 2-Lead Galvanic Cell Ground-Referred

7.3.1.6.3 2-lead Galvanic Cell in Potentiostat Configuration

When the LMP91000 is interfaced to a galvanic cell (for instance to an Oxygen gas sensor) referred to a reference, the Counter and the Reference pin of the LMP91000 are shorted together and connected to negative electrode of the galvanic cell. The positive electrode of the galvanic cell is then connected to the Working pin of the LMP91000.

The LMP91000 is then configured in 3-lead amperometric cell mode (as for amperometric cell). In this configuration the Control Amplifier (A1) is ON and provides the internal zero voltage. The transimpedance amplifier (TIA) is also ON, it converts the current generated by the gas sensor in a voltage, according to the transimpedance gain:

$$\text{Gain} = R_{TIA} \tag{7}$$

If different gains are required, an external resistor can be connected between the pins C1 and C2. In this case the internal feedback resistor should be programmed to “external”.

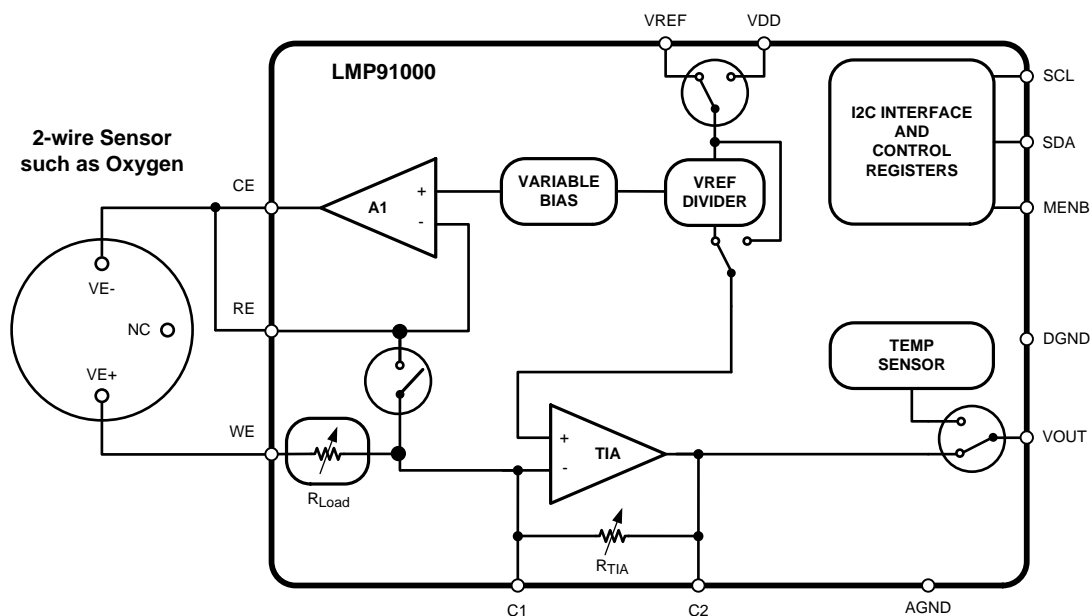

Figure 26. 2-Lead Galvanic Cell in Potentiostat Configuration

7.3.1.7 Timeout Feature

The timeout is a safety feature to avoid bus lockup situation. If SCL is stuck low for a time exceeding t_{timeout} , the LMP91000 will automatically reset its I²C interface. Also, in the case the LMP91000 hangs the SDA for a time exceeding t_{timeout} , the LMP91000's I²C interface will be reset so that the SDA line will be released. Since the SDA is an open-drain with an external resistor pull-up, this also avoids high power consumption when LMP91000 is driving the bus and the SCL is stopped.

7.4 Device Functional Modes

The LMP91000 has 6 operational modes to optimize the current consumption and meet the needs of the applications. It is possible to select the operational mode through the I2C bus.

At the power on the LMP91000 is in deep sleep mode. In this mode the device accepts I2C commands and burns the lowest supply current. In this mode the TIA, the A1 control amplifier and the temperature sensor are OFF. This mode of operation is suggested when the gas detector is not used and a zero bias is required between WE and RE electrodes of the gas sensor. The zero bias between the WE and RE electrodes is kept by enabling the internal FET feature.

In the standby mode, the TIA is OFF, while the A1 control amplifier is ON. This mode of operation is suggested when the gas detector is not used for short amount of time and a faster warm-up of the gas detector is required.

Device Functional Modes (continued)

In the 3-lead amperometric cell, the LMP91000 is configured as a standard potentiostat with A1, TIA and bias circuitry completely ON.

In the Temperature measurement (TIA OFF) the LMP91000 is in Standby mode with the Temperature sensor ON, at the VOUT pin of the LMP91000 it is possible to read the temperature sensor's output.

In the Temperature measurement (TIA ON) the LMP91000 is 3-lead amperometric cell mode with the Temperature sensor ON, at the VOUT pin of the LMP91000 it is possible to read the temperature sensor's output.

In 2-lead ground referred galvanic cell the A1 control amplifier is OFF and the Internal zero circuitry is bypassed. In this mode it is possible to connect 2-lead sensors like the O2 sensor to the LMP91000.

7.5 Programming

7.5.1 I²C Interface

The I²C compatible interface operates in Standard mode (100kHz). Pull-up resistors or current sources are required on the SCL and SDA pins to pull them high when they are not being driven low. A logic zero is transmitted by driving the output low. A logic high is transmitted by releasing the output and allowing it to be pulled-up externally. The appropriate pull-up resistor values will depend upon the total bus capacitance and operating speed. The LMP91000 comes with a 7 bit bus fixed address: 1001 000.

7.5.2 Write and Read Operation

In order to start any read or write operation with the LMP91000, MENB needs to be set low during the whole communication. Then the master generates a start condition by driving SDA from high to low while SCL is high. The start condition is always followed by a 7-bit slave address and a Read/Write bit. After these 8 bits have been transmitted by the master, SDA is released by the master and the LMP91000 either ACKs or NACKs the address. If the slave address matches, the LMP91000 ACKs the master. If the address doesn't match, the LMP91000 NACKs the master. For a write operation, the master follows the ACK by sending the 8-bit register address pointer. Then the LMP91000 ACKs the transfer by driving SDA low. Next, the master sends the 8-bit data to the LMP91000. Then the LMP91000 ACKs the transfer by driving SDA low. At this point the master should generate a stop condition and optionally set the MENB at logic high level (refer to [Figure 27](#), [Figure 28](#), and [Figure 29](#)).

A read operation requires the LMP91000 address pointer to be set first, also in this case the master needs setting at low logic level the MENB, then the master needs to write to the device and set the address pointer before reading from the desired register. This type of read requires a start, the slave address, a write bit, the address pointer, a Repeated Start (if appropriate), the slave address, and a read bit (refer to [Figure 27](#), [Figure 28](#), and [Figure 29](#)). Following this sequence, the LMP91000 sends out the 8-bit data of the register.

When just one LMP91000 is present on the I²C bus the MENB can be tied to ground (low logic level).

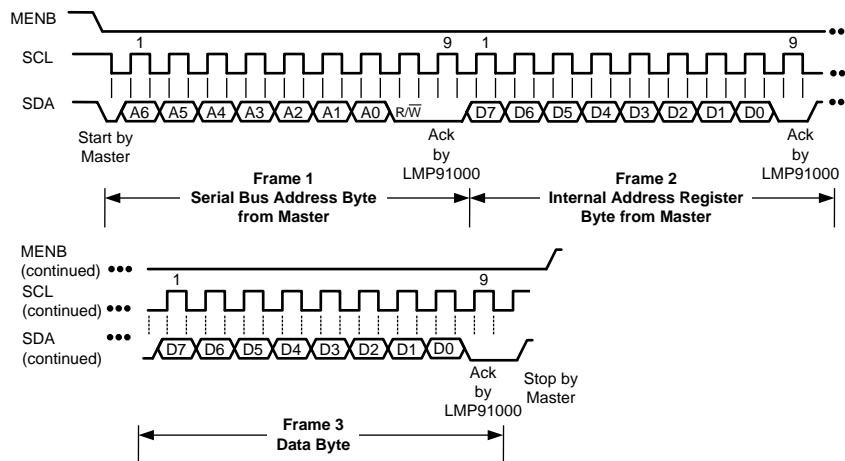

Figure 27. Register Write Transaction

Programming (continued)

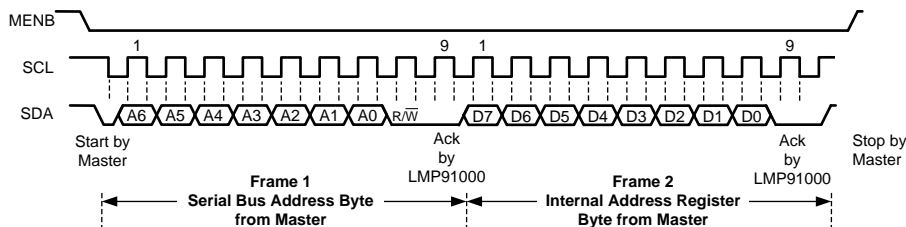

Figure 28. Pointer Set Transaction

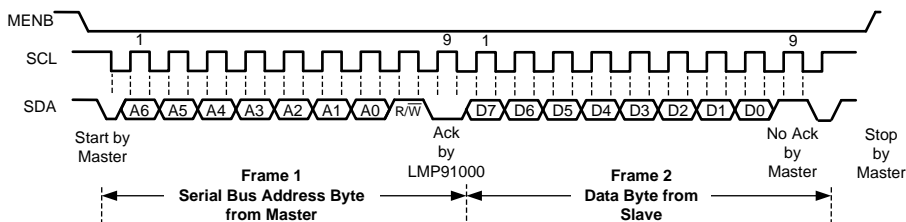

Figure 29. Register Read Transaction

7.6 Registers Maps

The registers are used to configure the LMP91000.

If writing to a reserved bit, user must write only 0. Readback value is unspecified and should be discarded.

Table 2. Register Map

Address	Name	Power on default	Access	Lockable?
0x00	STATUS	0x00	Read only	No
0x01	LOCK	0x01	R/W	No
0x02 through 0x09	RESERVED	—	—	—
0x10	TIACN	0x03	R/W	Yes
0x11	REFCN	0x20	R/W	Yes
0x12	MODECN	0x00	R/W	No
0x13 through 0xFF	RESERVED	—	—	—

7.6.1 STATUS -- Status Register (Address 0x00)

The status bit is an indication of the LMP91000's power-on status. If its readback is "0", the LMP91000 is not ready to accept other I²C commands.

Bit	Name	Function
[7:1]	RESERVED	
0	STATUS	Status of Device 0 Not Ready (default) 1 Ready

7.6.2 LOCK -- Protection Register (Address 0x01)

The lock bit enables and disables the writing of the TIACN and the REFCN registers. In order to change the content of the TIACN and the REFCN registers the lock bit needs to be set to "0".

Bit	Name	Function
[7:1]	RESERVED	
0	LOCK	Write protection 0 Registers 0x10, 0x11 in write mode 1 Registers 0x10, 0x11 in read only mode (default)

7.6.3 TIACN -- TIA Control Register (Address 0x10)

The parameters in the TIA control register allow the configuration of the transimpedance gain (R_{TIA}) and the load resistance (R_{Load}).

Bit	Name	Function
[7:5]	RESERVED	RESERVED
[4:2]	TIA_GAIN	TIA feedback resistance selection 000 External resistance (default) 001 2.75k Ω 010 3.5k Ω 011 7k Ω 100 14k Ω 101 35k Ω 110 120k Ω 111 350k Ω
[1:0]	RLOAD	R_{Load} selection 00 10 Ω 01 33 Ω 10 50 Ω 11 100Ω (default)

7.6.4 REFCN -- Reference Control Register (Address 0x11)

The parameters in the Reference control register allow the configuration of the Internal zero, Bias and Reference source. When the Reference source is external, the reference is provided by a reference voltage connected to the VREF pin. In this condition the Internal Zero and the Bias voltage are defined as a percentage of VREF voltage instead of the supply voltage.

Bit	Name	Function
7	REF_SOURCE	Reference voltage source selection 0 Internal (default) 1 external
[6:5]	INT_Z	Internal zero selection (Percentage of the source reference) 00 20% 01 50% (default) 10 67% 11 Internal zero circuitry bypassed (only in O ₂ ground referred measurement)
4	BIAS_SIGN	Selection of the Bias polarity 0 Negative ($V_{WE} - V_{RE}$) < 0V (default) 1 Positive ($V_{WE} - V_{RE}$) > 0V
[3:0]	BIAS	BIAS selection (Percentage of the source reference) 0000 0% (default) 0001 1% 0010 2% 0011 4% 0100 6% 0101 8% 0110 10% 0111 12% 1000 14% 1001 16% 1010 18% 1011 20% 1100 22% 1101 24%

7.6.5 MODECN -- Mode Control Register (Address 0x12)

The Parameters in the Mode register allow the configuration of the Operation Mode of the LMP91000.

Bit	Name	Function
7	FET_SHORT	Shorting FET feature 0 Disabled (default) 1 Enabled
[6:3]	RESERVED	
[2:0]	OP_MODE	Mode of Operation selection 000 Deep Sleep (default) 001 2-lead ground referred galvanic cell 010 Standby 011 3-lead amperometric cell 110 Temperature measurement (TIA OFF) 111 Temperature measurement (TIA ON)

When the LMP91000 is in Temperature measurement (TIA ON) mode, the output of the temperature sensor is present at the VOUT pin, while the output of the potentiostat circuit is available at pin C2.

8 Application and Implementation

NOTE

Information in the following applications sections is not part of the TI component specification, and TI does not warrant its accuracy or completeness. TI's customers are responsible for determining suitability of components for their purposes. Customers should validate and test their design implementation to confirm system functionality.

8.1 Application Information

8.1.1 Connection of More Than One LMP91000 to the I²C BUS

The LMP91000 comes out with a unique and fixed I²C slave address. It is still possible to connect more than one LMP91000 to an I²C bus and select each device using the MENB pin. The MENB simply enables/disables the I²C communication of the LMP91000. When the MENB is at logic level low all the I²C communication is enabled, it is disabled when MENB is at high logic level.

In a system based on a μ controller and more than one LMP91000 connected to the I²C bus, the I²C lines (SDA and SCL) are shared, while the MENB of each LMP91000 is connected to a dedicate GPIO port of the μ controller.

The μ controller starts communication asserting one out of N MENB signals where N is the total number of LMP91000s connected to the I²C bus. Only the enabled device will acknowledge the I²C commands. After finishing communicating with this particular LMP91000, the microcontroller de-asserts the corresponding MENB and repeats the procedure for other LMP91000s. [Figure 30](#) shows the typical connection when more than one LMP91000 is connected to the I²C bus.

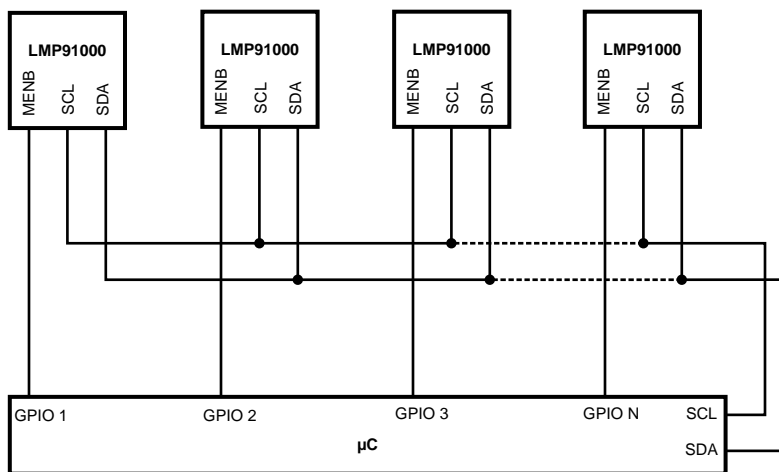

Figure 30. More Than One LMP91000 on I²C Bus

8.1.2 Smart Gas Sensor Analog Front-End

The LMP91000 together with an external EEPROM represents the core of a SMART GAS SENSOR AFE. In the EEPROM it is possible to store the information related to the GAS sensor type, calibration and LMP91000's configuration (content of registers 10h, 11h, 12h). At startup the microcontroller reads the EEPROM's content and configures the LMP91000. A typical smart gas sensor AFE is shown in [Figure 31](#). The connection of MENB to the hardware address pin A0 of the EEPROM allows the microcontroller to select the LMP91000 and its corresponding EEPROM when more than one smart gas sensor AFE is present on the I²C bus. Note: only EEPROM I²C addresses with A0=0 should be used in this configuration.

Application Information (continued)

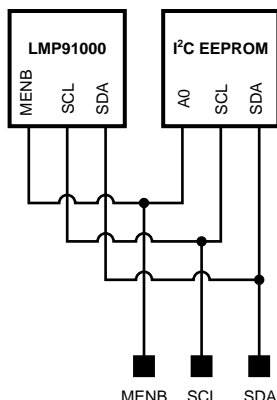

Figure 31. Smart Gas Sensor AFE

8.1.3 Smart Gas Sensor AFES on I²C BUS

The connection of Smart gas sensor AFEs on the I²C bus is the natural extension of the previous concepts. Also in this case the microcontroller starts communication asserting 1 out of N MENB signals where N is the total number of smart gas sensor AFE connected to the I²C bus. Only one of the devices (either LMP91000 or its corresponding EEPROM) in the smart gas sensor AFE enabled will acknowledge the I²C commands. When the communication with this particular module ends, the microcontroller de-asserts the corresponding MENB and repeats the procedure for other modules. Figure 32 shows the typical connection when several smart gas sensor AFEs are connected to the I²C bus.

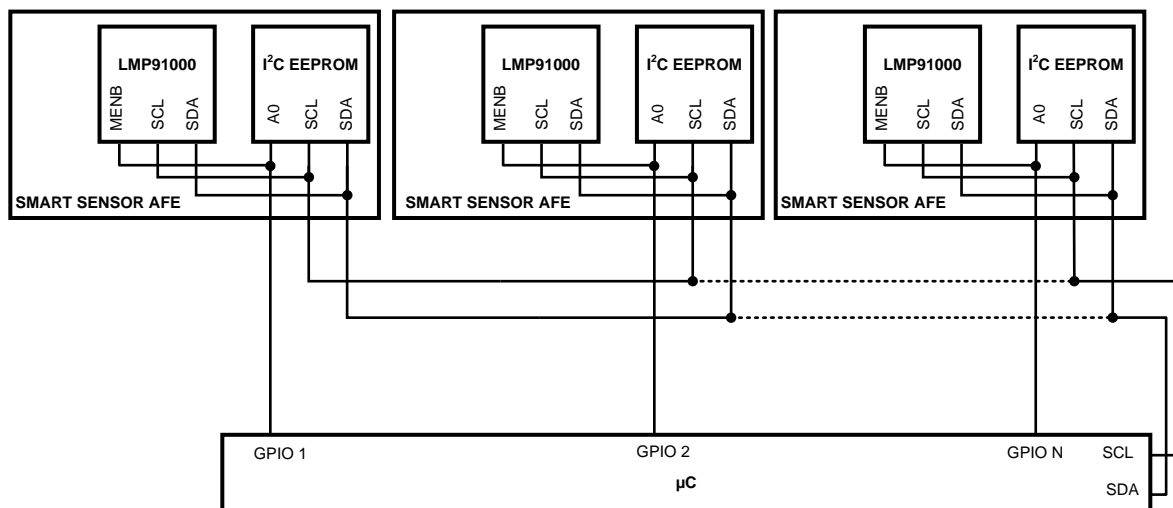

Figure 32. I²C Bus

8.2 Typical Application

The LMP91000 can be used in conjunction with environment sensors to build a battery power environment monitors such as an air quality data-loggers, or wireless sensors. In this application due to the monitored phenomena the micro-controller and the LMP91000 spend most of the time in idle state. In order to save power and enlarge the battery life, the LMP91000 can be put in deep sleep mode with Internal FET feature enabled. To optimize the current consumption of the entire system, the acquisitions and in general the activities of the micro can operate at set intervals with the TPL5000. The TPL5000 is a programmable timer with watch-dog feature.

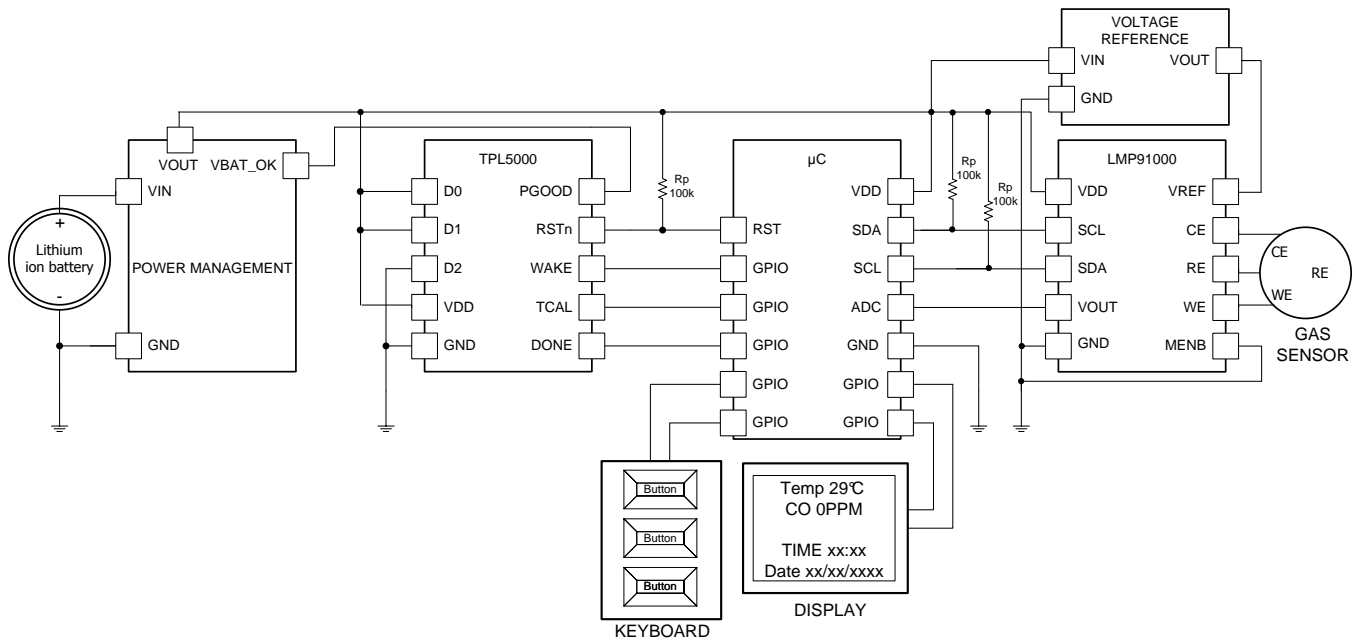

Figure 33. Data-Logger

8.2.1 Design Requirements

The Design is driven by the low-current consumption constraint. The data are usually acquired on a rate that ranges between 1s to 10s. The highest necessity is the maximization of the battery life. The TPL5000 helps achieving that goal because it allows putting the micro-controller in its lowest power mode. Moreover the deep sleep mode of the LMP91000 allows burning only some hundreds of nA.

8.2.2 Detailed Design Procedure

When the focal constraint is the battery, the selection of a low power voltage reference, a micro-controller and display is mandatory. The first step in the design is the calculation of the power consumption of each device in the different mode of operations. An example is the LMP91000; the device has gas measurement mode, sleep mode and micro-controller in low power mode which is normal operation. The different modes offer the possibility to select the appropriate timer interval which respect the application constraint and maximize the life of the battery.

8.2.2.1 Sensor Test Procedure

The LMP91000 has all the hardware and programmability features to implement some test procedures. The purpose of the test procedure is to:

- test proper function of the sensor (status of health)
- test proper connection of the sensor to the LMP91000

The test procedure is very easy. The variable bias block is user programmable through the digital interface. A step voltage can be applied by the end user to the positive input of A1. As a consequence a transient current will start flowing into the sensor (to charge its internal capacitance) and it will be detected by the TIA. If the current transient is not detected, either a sensor fault or a connection problem is present. The slope and the aspect of the transient response can also be used to detect sensor aging (for example, a cell that is drying and no longer

Typical Application (continued)

efficiently conducts the current). After it is verified that the sensor is working properly, the LMP91000 needs to be reset to its original configuration. It is not required to observe the full transient in order to contain the testing time. All the needed information are included in the transient slopes (both edges). Figure 34 shows an example of the test procedure, a Carbon Monoxide sensor is connected to the LMP91000, two pulses are then sequentially applied to the bias voltage:

1. from 0 mV to 40 mV
2. from 40 mV to -40 mV

and finally the bias is set again at 0mV since this is the normal operation condition for this sensor.

8.2.3 Application Curve

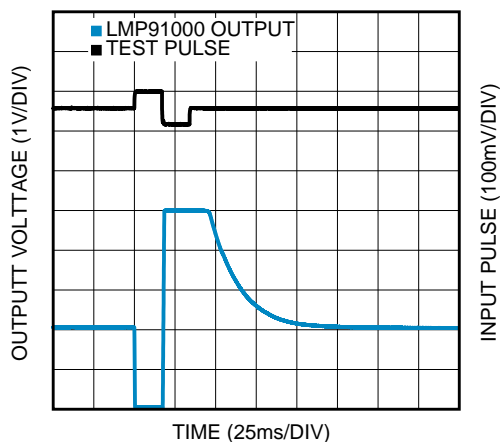

Figure 34. Test Procedure Example

9 Power Supply Recommendations

9.1 Power Consumption

The LMP91000 is intended for use in portable devices, so the power consumption is as low as possible in order to ensure a long battery life. The total power consumption for the LMP91000 is below 10 μA at 3.3 v average over time, (this excludes any current drawn from any pin). A typical usage of the LMP91000 is in a portable gas detector and its power consumption is summarized in [Table 3](#). This has the following assumptions:

- Power On only happens a few times over life, so its power consumption can be ignored.
- Deep Sleep mode is not used.
- The system is used about 8 hours a day, and 16 hours a day it is in Standby mode.
- Temperature Measurement is done about once per minute.

This results in an average power consumption of approximately 7.95 μA . This can potentially be further reduced, by using the Standby mode between gas measurements. It may even be possible, depending on the sensor used, to go into deep sleep for some time between measurements, further reducing the average power consumption.

Table 3. Power Consumption Scenario

	Deep Sleep	StandBy	3-Lead Amperometric Cell	Temperature Measurement TIA OFF	Temperature Measurement TIA ON	Total
Current consumption (μA) typical value	0.6	6.5	10	11.4	14.9	
Time ON (%)	0	60	39	0	1	
Average (μA)	0	3.9	3.9	0	0.15	7.95
Notes						
A1	OFF	ON	ON	ON	ON	
TIA	OFF	OFF	ON	OFF	ON	
TEMP SENSOR	OFF	OFF	OFF	ON	ON	
I ² C interface	ON	ON	ON	ON	ON	

10 Layout

10.1 Layout Guidelines

The most critical point when designing with electrochemical gas sensors and the LMP91000 is the connection of the sensor to the front-end. Particular attention is required in the layout of the RE, CE and WE traces which connect the sensor to the front-end. The traces need to be short and far from high frequency signals, such as clock. A way to reduce the length of the traces is positioning the LMP91000 below the gas sensor, this is possible with cylindrical electrochemical gas sensor or on the opposite layer in case of solid gas sensor or low profile gas sensor. In case of usage of external transimpedance gain resistance it needs to be placed close to the LMP91000, the terminal of the resistance connected to C1 needs to be far from high frequency signals.

10.2 Layout Example

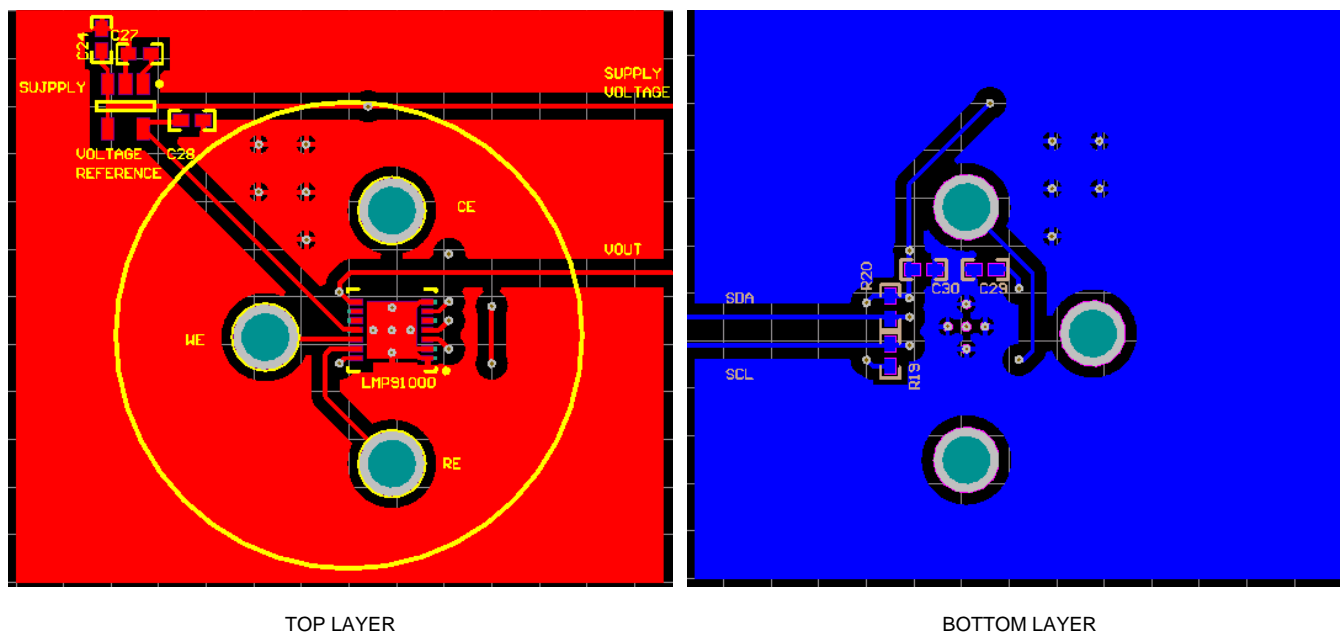

Figure 35. Layout

11 Device and Documentation Support

11.1 Trademarks

WEBENCH is a registered trademark of Texas Instruments.
All other trademarks are the property of their respective owners.

11.2 Electrostatic Discharge Caution



These devices have limited built-in ESD protection. The leads should be shorted together or the device placed in conductive foam during storage or handling to prevent electrostatic damage to the MOS gates.

11.3 Glossary

[SLYZ022](#) — *TI Glossary*.

This glossary lists and explains terms, acronyms, and definitions.

12 Mechanical, Packaging, and Orderable Information

The following pages include mechanical, packaging, and orderable information. This information is the most current data available for the designated devices. This data is subject to change without notice and revision of this document. For browser-based versions of this data sheet, refer to the left-hand navigation.

PACKAGING INFORMATION

Orderable Device	Status (1)	Package Type	Package Drawing	Pins	Package Qty	Eco Plan (2)	Lead finish/ Ball material (6)	MSL Peak Temp (3)	Op Temp (°C)	Device Marking (4/5)	Samples
LMP91000SDX/NOPB	ACTIVE	WSON	NHL	14	4500	RoHS & Green	SN	Level-3-260C-168 HR	-40 to 85	L91000	Samples

(1) The marketing status values are defined as follows:

ACTIVE: Product device recommended for new designs.

LIFEBUY: TI has announced that the device will be discontinued, and a lifetime-buy period is in effect.

NRND: Not recommended for new designs. Device is in production to support existing customers, but TI does not recommend using this part in a new design.

PREVIEW: Device has been announced but is not in production. Samples may or may not be available.

OBSELETE: TI has discontinued the production of the device.

(2) **RoHS:** TI defines "RoHS" to mean semiconductor products that are compliant with the current EU RoHS requirements for all 10 RoHS substances, including the requirement that RoHS substance do not exceed 0.1% by weight in homogeneous materials. Where designed to be soldered at high temperatures, "RoHS" products are suitable for use in specified lead-free processes. TI may reference these types of products as "Pb-Free".

RoHS Exempt: TI defines "RoHS Exempt" to mean products that contain lead but are compliant with EU RoHS pursuant to a specific EU RoHS exemption.

Green: TI defines "Green" to mean the content of Chlorine (Cl) and Bromine (Br) based flame retardants meet JS709B low halogen requirements of <=1000ppm threshold. Antimony trioxide based flame retardants must also meet the <=1000ppm threshold requirement.

(3) MSL, Peak Temp. - The Moisture Sensitivity Level rating according to the JEDEC industry standard classifications, and peak solder temperature.

(4) There may be additional marking, which relates to the logo, the lot trace code information, or the environmental category on the device.

(5) Multiple Device Markings will be inside parentheses. Only one Device Marking contained in parentheses and separated by a "-" will appear on a device. If a line is indented then it is a continuation of the previous line and the two combined represent the entire Device Marking for that device.

(6) Lead finish/Ball material - Orderable Devices may have multiple material finish options. Finish options are separated by a vertical ruled line. Lead finish/Ball material values may wrap to two lines if the finish value exceeds the maximum column width.

Important Information and Disclaimer:The information provided on this page represents TI's knowledge and belief as of the date that it is provided. TI bases its knowledge and belief on information provided by third parties, and makes no representation or warranty as to the accuracy of such information. Efforts are underway to better integrate information from third parties. TI has taken and continues to take reasonable steps to provide representative and accurate information but may not have conducted destructive testing or chemical analysis on incoming materials and chemicals. TI and TI suppliers consider certain information to be proprietary, and thus CAS numbers and other limited information may not be available for release.

In no event shall TI's liability arising out of such information exceed the total purchase price of the TI part(s) at issue in this document sold by TI to Customer on an annual basis.

TAPE AND REEL INFORMATION

QUADRANT ASSIGNMENTS FOR PIN 1 ORIENTATION IN TAPE

*All dimensions are nominal

Device	Package Type	Package Drawing	Pins	SPQ	Reel Diameter (mm)	Reel Width W1 (mm)	A0 (mm)	B0 (mm)	K0 (mm)	P1 (mm)	W (mm)	Pin1 Quadrant
LMP9100SDX/NOPB	WSO	NHL	14	4500	330.0	12.4	4.3	4.3	1.3	8.0	12.0	Q1

TAPE AND REEL BOX DIMENSIONS

*All dimensions are nominal

Device	Package Type	Package Drawing	Pins	SPQ	Length (mm)	Width (mm)	Height (mm)
LMP91000SDX/NOPB	WSON	NHL	14	4500	356.0	356.0	35.0

NHL0014B

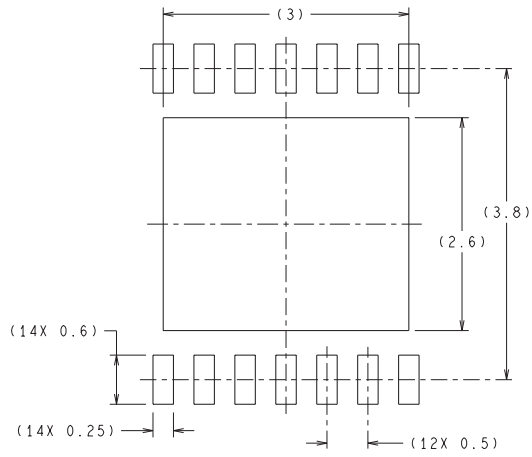

RECOMMENDED LAND PATTERN

DIMENSIONS ARE IN MILLIMETERS
DIMENSIONS IN () FOR REFERENCE ONLY

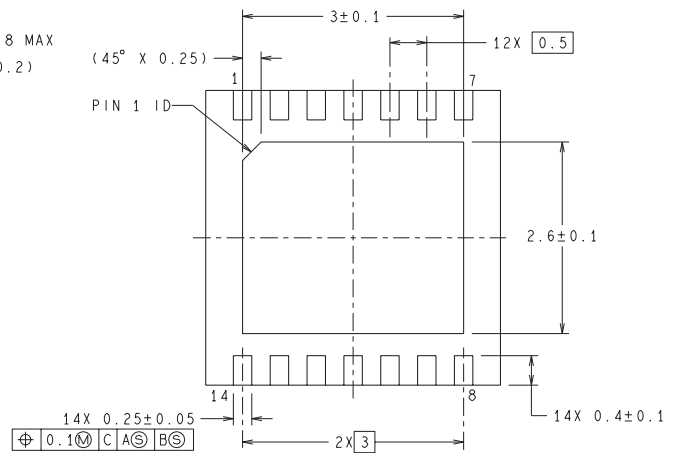
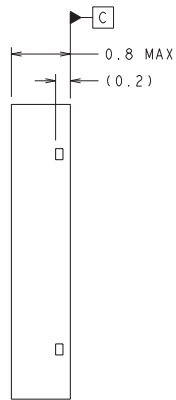
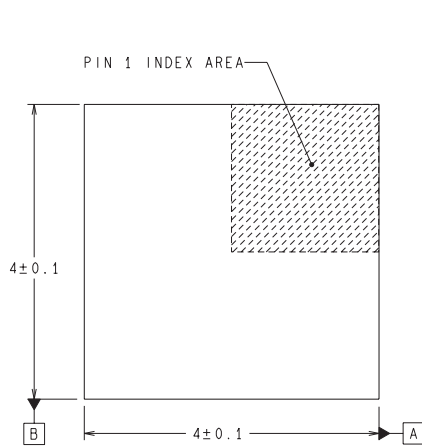
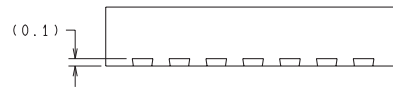

SDA14B (Rev A)

IMPORTANT NOTICE AND DISCLAIMER

TI PROVIDES TECHNICAL AND RELIABILITY DATA (INCLUDING DATA SHEETS), DESIGN RESOURCES (INCLUDING REFERENCE DESIGNS), APPLICATION OR OTHER DESIGN ADVICE, WEB TOOLS, SAFETY INFORMATION, AND OTHER RESOURCES "AS IS" AND WITH ALL FAULTS, AND DISCLAIMS ALL WARRANTIES, EXPRESS AND IMPLIED, INCLUDING WITHOUT LIMITATION ANY IMPLIED WARRANTIES OF MERCHANTABILITY, FITNESS FOR A PARTICULAR PURPOSE OR NON-INFRINGEMENT OF THIRD PARTY INTELLECTUAL PROPERTY RIGHTS.

These resources are intended for skilled developers designing with TI products. You are solely responsible for (1) selecting the appropriate TI products for your application, (2) designing, validating and testing your application, and (3) ensuring your application meets applicable standards, and any other safety, security, regulatory or other requirements.

These resources are subject to change without notice. TI grants you permission to use these resources only for development of an application that uses the TI products described in the resource. Other reproduction and display of these resources is prohibited. No license is granted to any other TI intellectual property right or to any third party intellectual property right. TI disclaims responsibility for, and you will fully indemnify TI and its representatives against, any claims, damages, costs, losses, and liabilities arising out of your use of these resources.

TI's products are provided subject to [TI's Terms of Sale](#) or other applicable terms available either on [ti.com](https://www.ti.com) or provided in conjunction with such TI products. TI's provision of these resources does not expand or otherwise alter TI's applicable warranties or warranty disclaimers for TI products.

TI objects to and rejects any additional or different terms you may have proposed.

Mailing Address: Texas Instruments, Post Office Box 655303, Dallas, Texas 75265
Copyright © 2024, Texas Instruments Incorporated