

LSF0102-Q1 Automotive 2-Channel Auto Bidirectional Multi-Voltage Level Translator

1 Features

- AEC-Q100 Qualified for Automotive Applications
 - Temperature Grade 1: $-40^{\circ}\text{C} \leq T_A \leq 125^{\circ}\text{C}$
 - Device HBM ESD Classification Level 2
 - CDM ESD Classification Level C6
- Provides Bidirectional Voltage Translation With No Direction Pin
- Supports open drain and push-pull applications such as I²C, SPI, UART, MDIO, SDIO, and GPIO
- Supports Up to 100 MHz Up Translation and Greater Than 100 MHz Down Translation at $\leq 30\text{pF}$ Cap Load and Up To 40 MHz Up/Down Translation at 50 pF Cap Load
- Enables Bidirectional Voltage Level Translation Between
 - $0.95\text{ V} \leftrightarrow 1.8/2.5/3.3/5\text{ V}$
 - $1.2\text{ V} \leftrightarrow 1.8/2.5/3.3/5\text{ V}$
 - $1.8\text{ V} \leftrightarrow 2.5/3.3/5\text{ V}$
 - $2.5\text{ V} \leftrightarrow 3.3/5\text{ V}$
 - $3.3\text{ V} \leftrightarrow 5\text{ V}$
- Low Standby Current
- 5 V Tolerant I/O Ports to Support TTL Voltage Levels
- Low r_{on} Provides Less Signal Distortion
- High-Impedance I/O pins when EN = Low
- Flow-Through Pinout for Ease of PCB Trace Routing
- Latch-Up Performance Exceeds 100 mA Per JESD 78, Class II

2 Applications

- Infotainment Head Unit
- Graphical Cluster
- ADAS Fusion
- ADAS Front Camera
- HEV Battery Management System

3 Description

The LSF0102-Q1 device is an auto bidirectional voltage translator that translates among a wide range of supplies without the need for a directional pin. The LSF0102-Q1 supports up to 100 MHz up translation and greater than 100 MHz down translation with capacitive loads $\leq 30\text{ pF}$. Additionally, the LSF0102-Q1 supports up to 40 MHz up and down translation at 50 pF capacitance load, which enables the LSF0102-Q1 device to support a wide variety of standard interfaces commonly found in automotive applications such as I²C, SPI, GPIO, SDIO, UART, and MDIO.

The LSF0102-Q1 device has 5-V tolerant data inputs. This makes the device compatible with TTL voltage levels. Furthermore, the LSF0102-Q1 supports mixed-mode voltage translation, allowing the device to up translate and down translate to different supply levels on each channel.

Device Information⁽¹⁾

| PART NUMBER | PACKAGE(PINS) | BODY SIZE (NOM) |
|----------------|---------------|-------------------|
| LSF0102QDCURQ1 | VSSOP (8) | 2.30 mm × 2.00 mm |

- (1) For all available packages, see the orderable addendum at the end of the data sheet.

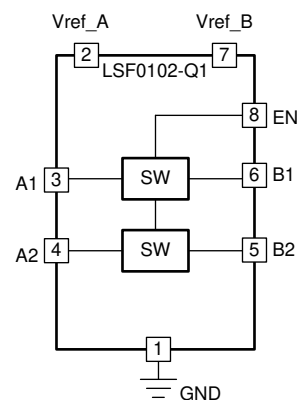

Table of Contents

| | | | |
|---|---|--|----|
| 1 Features | 1 | 7.1 Overview..... | 9 |
| 2 Applications | 1 | 7.2 Functional Block Diagrams..... | 9 |
| 3 Description | 1 | 7.3 Feature Description..... | 9 |
| 4 Revision History | 2 | 7.4 Device Functional Modes..... | 10 |
| 5 Pin Configuration and Functions | 3 | 8 Application and Implementation | 10 |
| 6 Specifications | 4 | 8.1 Application Information..... | 10 |
| 6.1 Absolute Maximum Ratings..... | 4 | 8.2 Typical Application..... | 10 |
| 6.2 ESD Ratings..... | 4 | 9 Power Supply Recommendations | 12 |
| 6.3 Recommended Operating Conditions..... | 4 | 10 Layout | 12 |
| 6.4 Thermal Information..... | 4 | 10.1 Layout Guidelines..... | 12 |
| 6.5 Electrical Characteristics..... | 5 | 10.2 Layout Example..... | 12 |
| 6.6 Switching Characteristics (Translating Down): | | 11 Device and Documentation Support | 13 |
| $V_{GATE} = 3.3\text{ V}$ | 6 | 11.1 Documentation Support..... | 13 |
| 6.7 Switching Characteristics (Translating Down): | | 11.2 Receiving Notification of Documentation Updates.. | 13 |
| $V_{GATE} = 2.5\text{ V}$ | 6 | 11.3 Support Resources..... | 13 |
| 6.8 Switching Characteristics Translating Up): V_{GATE} | | 11.4 Trademarks..... | 13 |
| = 3.3 V..... | 6 | 11.5 Electrostatic Discharge Caution..... | 13 |
| 6.9 Switching Characteristics (Translating Up): | | 11.6 Glossary..... | 13 |
| $V_{GATE} = 2.5\text{ V}$ | 6 | 12 Mechanical, Packaging, and Orderable | |
| 6.10 Typical Characteristics..... | 7 | Information | 13 |
| 7 Detailed Description | 9 | | |

4 Revision History

NOTE: Page numbers for previous revisions may differ from page numbers in the current version.

| Changes from Revision * (May 2018) to Revision A (April 2021) | Page |
|---|------|
| • Updated the numbering format for tables, figures, and cross-references throughout the document..... | 1 |
| • Updated the <i>Bidirectional Translation</i> section to include inclusive terminology..... | 11 |

5 Pin Configuration and Functions

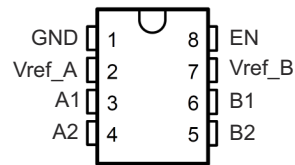

Figure 5-1. LSF0102-Q1 DCU Package 8-Pin VSSOP Top View

Table 5-1. Pin Functions

| PIN | | I/O | DESCRIPTION |
|--------|-----|-----|--|
| NAME | DCU | | |
| A1 | 3 | I/O | Input/Output A port for Channel 1 |
| A2 | 4 | I/O | Input/Output A port for Channel 2 |
| B1 | 6 | I/O | Input/Output B port for Channel 1 |
| B2 | 5 | I/O | Input/Output B port for Channel 2 |
| EN | 8 | I | I/O enable input; see Figure 8-1 for typical setup. Should be tied directly to Vref_B to be enabled or pulled LOW to disable all I/O pins. |
| GND | 1 | — | Ground |
| Vref_A | 2 | — | A side reference supply voltage; see Section 8 for setup and supply voltage range. |
| Vref_B | 7 | — | B side reference supply voltage. Must be connected to supply through 200 kΩ; see Section 8 for setup and supply voltage range. |

6 Specifications

6.1 Absolute Maximum Ratings

over operating free-air temperature (unless otherwise noted)⁽¹⁾

| | MIN | MAX | UNIT |
|---|-----------|-----|------|
| Input voltage ⁽²⁾ , V_I | -0.5 | 7 | V |
| Input/output voltage ⁽²⁾ , $V_{I/O}$ | -0.5 | 7 | V |
| Continuous channel current | | 128 | mA |
| Input clamp current, I_{IK} | $V_I < 0$ | -50 | mA |
| Storage temperature range, T_{stg} | -65 | 150 | °C |
| Operating junction temperature, T_J | | 150 | °C |

- (1) Stresses beyond those listed under *Absolute Maximum Ratings* may cause permanent damage to the device. These are stress ratings only, and functional operation of the device at these or any other conditions beyond those indicated under *Recommended Operating Conditions* is not implied. Exposure to absolute-maximum-rated conditions for extended periods may affect device reliability.
- (2) The input and input/output negative-voltage ratings may be exceeded if the input and input/output clamp-current ratings are observed.

6.2 ESD Ratings

| | VALUE | UNIT |
|-------------------------------------|---|-------|
| $V_{(ESD)}$ Electrostatic discharge | Human-body model (HBM), per AEC Q100-002 ⁽¹⁾ | ±2000 |
| | Charged-device model (CDM), per AEC Q100-011 | ±1000 |

- (1) AEC Q100-002 indicates that HBM stressing shall be in accordance with the ANSI/ESDA/JEDEC JS-001 specification.

6.3 Recommended Operating Conditions

over operating free-air temperature range (unless otherwise noted)

| | MIN | MAX | UNIT |
|--------------------------------------|-----|-----|------|
| $V_{I/O}$ Input/output voltage | | 5 | V |
| $V_{ref_A/B/EN}$ Reference voltage | | 5 | V |
| I_{PASS} Pass transistor current | | 64 | mA |
| T_A Operating free-air temperature | -40 | 125 | °C |

6.4 Thermal Information

| THERMAL METRIC ⁽¹⁾ | LSF0102-Q1 | UNIT |
|--|------------|------|
| | DCU (US8) | |
| | 8 PINS | |
| $R_{\theta JA}$ Junction-to-ambient thermal resistance | 229.3 | °C/W |
| $R_{\theta JC(top)}$ Junction-to-case (top) thermal resistance | 106.5 | °C/W |
| $R_{\theta JB}$ Junction-to-board thermal resistance | 141.7 | °C/W |
| ψ_{JT} Junction-to-top characterization parameter | 35.3 | °C/W |
| ψ_{JB} Junction-to-board characterization parameter | 141.4 | °C/W |

- (1) For more information about traditional and new thermal metrics, see the [IC Package Thermal Metrics](#) application report.

6.5 Electrical Characteristics

over recommended operating free-air temperature range (unless otherwise noted)

| PARAMETER | | TEST CONDITIONS | MIN | TYP ⁽¹⁾ | MAX | UNIT |
|---|--|--|--|--------------------|------|---------------|
| V_{IK} | Input clamp voltage | $I_I = -18 \text{ mA}$, $V_{EN} = 0$ | | | -1.2 | V |
| I_{IH} | I/O input high leakage | $V_I = 5 \text{ V}$, $V_{EN} = 0$ | | | 5.0 | μA |
| I_{CCBA} | V_{ref_B} to V_{ref_A} leakage | $V_{ref_B} = V_{EN} = 5.5 \text{ V}$, $V_{ref_A} = 4.5 \text{ V}$, $I_O = 0$, $V_I = V_{CC}$ or GND | | | 1 | μA |
| $C_{I(ref_A/B/EN)}$ | Input capacitance | $V_I = 3 \text{ V}$ or 0 | | | 11 | pF |
| $C_{io(off)}$ | I/O pin off-state capacitance | $V_O = 3 \text{ V}$ or 0, $V_{EN} = 0$ | | 4.0 | 6.0 | pF |
| $C_{io(on)}$ | I/O Pin on-state capacitance | $V_O = 3 \text{ V}$ or 0, $V_{EN} = 3 \text{ V}$ | | 10.5 | 12.5 | pF |
| $r_{on}^{(2)}$ | On-state resistance | $V_I = 0$, $I_O = 64 \text{ mA}$ | $V_{ref_A} = 3.3 \text{ V}$; $V_{ref_B} = V_{EN} = 5 \text{ V}$ | | 8.0 | Ω |
| | | | $V_{ref_A} = 1.8 \text{ V}$; $V_{ref_B} = V_{EN} = 5 \text{ V}$ | | 9.0 | |
| | | | $V_{ref_A} = 1.0 \text{ V}$; $V_{ref_B} = V_{EN} = 5 \text{ V}$ | | 10 | |
| | | $V_I = 0$, $I_O = 32 \text{ mA}$ | $V_{ref_A} = 1.8 \text{ V}$; $V_{ref_B} = V_{EN} = 5 \text{ V}$ | | 10 | Ω |
| | | | $V_{ref_A} = 2.5 \text{ V}$; $V_{ref_B} = V_{EN} = 5 \text{ V}$ | | 15 | |
| | | $V_I = 1.8 \text{ V}$, $I_O = 15 \text{ mA}$ | $V_{ref_A} = 3.3 \text{ V}$; $V_{ref_B} = V_{EN} = 5 \text{ V}$ | | 9.0 | Ω |
| | | $V_I = 1.0 \text{ V}$, $I_O = 10 \text{ mA}$ | $V_{ref_A} = 1.8 \text{ V}$; $V_{ref_B} = V_{EN} = 3.3 \text{ V}$ | | 18 | Ω |
| | | $V_I = 0 \text{ V}$, $I_O = 10 \text{ mA}$ | $V_{ref_A} = 1.0 \text{ V}$; $V_{ref_B} = V_{EN} = 3.3 \text{ V}$ | | 20 | Ω |
| $V_I = 0 \text{ V}$, $I_O = 10 \text{ mA}$ | $V_{ref_A} = 1.0 \text{ V}$; $V_{ref_B} = V_{EN} = 1.8 \text{ V}$ | | 30 | Ω | | |

(1) All typical values are at $T_A = 25^\circ\text{C}$.

(2) Measured by the voltage drop between the A and B pins at the indicated current through the switch. On-state resistance is determined by the lowest voltage of the two (A or B) pins.

6.6 Switching Characteristics (Translating Down): $V_{GATE} = 3.3\text{ V}$

over recommended operating free-air temperature range, $V_{GATE} = 3.3\text{ V}$, $V_{IH} = 3.3\text{ V}$, $V_{IL} = 0$, and $V_M = 1.15\text{ V}$ (unless otherwise noted) (see [Section Parameter Measurement Information](#) table)

| PARAMETER | TEST CONDITIONS | $C_L = 50\text{ pF}$ | | | $C_L = 30\text{ pF}$ | | | $C_L = 15\text{ pF}$ | | | UNIT |
|-----------|--|----------------------|-----|-----|----------------------|-----|-----|----------------------|-----|-----|------|
| | | MIN | TYP | MAX | MIN | TYP | MAX | MIN | TYP | MAX | |
| t_{PLH} | Propagation delay time, low-to-high output From (input) A or B to (output) B or A | | 1.1 | | | 0.7 | | | 0.3 | | ns |
| t_{PHL} | Propagation delay time, high-to-low output From (input) A or B to (output) B or A | | 1.2 | | | 0.8 | | | 0.4 | | |

6.7 Switching Characteristics (Translating Down): $V_{GATE} = 2.5\text{ V}$

over recommended operating free-air temperature range, $V_{GATE} = 2.5\text{ V}$, $V_{IH} = 2.5\text{ V}$, $V_{IL} = 0$, and $V_M = 0.75\text{ V}$ (unless otherwise noted) (see [Section Parameter Measurement Information](#) table)

| PARAMETER | TEST CONDITIONS | $C_L = 50\text{ pF}$ | | | $C_L = 30\text{ pF}$ | | | $C_L = 15\text{ pF}$ | | | UNIT |
|-----------|--|----------------------|-----|-----|----------------------|-----|-----|----------------------|------|-----|------|
| | | MIN | TYP | MAX | MIN | TYP | MAX | MIN | TYP | MAX | |
| t_{PLH} | Propagation delay time, low-to-high output From (input) A or B to (output) B or A | | 1.2 | | | 0.8 | | | 0.35 | | ns |
| t_{PHL} | Propagation delay time, high-to-low output From (input) A or B to (output) B or A | | 1.3 | | | 1 | | | 0.5 | | |

6.8 Switching Characteristics Translating Up): $V_{GATE} = 3.3\text{ V}$

over recommended operating free-air temperature range, $V_{GATE} = 3.3\text{ V}$, $V_{IH} = 2.3\text{ V}$, $V_{IL} = 0$, $V_T = 3.3\text{ V}$, $V_M = 1.15\text{ V}$ and $R_L = 300$ (unless otherwise noted) (see [Section Parameter Measurement Information](#) table)

| PARAMETER | TEST CONDITIONS | $C_L = 50\text{ pF}$ | | | $C_L = 30\text{ pF}$ | | | $C_L = 15\text{ pF}$ | | | UNIT |
|-----------|--|----------------------|-----|-----|----------------------|-----|-----|----------------------|-----|-----|------|
| | | MIN | TYP | MAX | MIN | TYP | MAX | MIN | TYP | MAX | |
| t_{PLH} | Propagation delay time, low-to-high output From (input) A or B to (output) B or A | | 1 | | | 0.8 | | | 0.4 | | ns |
| t_{PHL} | Propagation delay time, high-to-low output From (input) A or B to (output) B or A | | 1 | | | 0.9 | | | 0.4 | | |

6.9 Switching Characteristics (Translating Up): $V_{GATE} = 2.5\text{ V}$

over recommended operating free-air temperature range, $V_{GATE} = 2.5\text{ V}$, $V_{IH} = 1.5\text{ V}$, $V_{IL} = 0$, $V_T = 2.5\text{ V}$, $V_M = 0.75\text{ V}$ and $R_L = 300$ (unless otherwise noted) (see [Section Parameter Measurement Information](#) table)

| PARAMETER | TEST CONDITIONS | $C_L = 50\text{ pF}$ | | | $C_L = 30\text{ pF}$ | | | $C_L = 15\text{ pF}$ | | | UNIT |
|-----------|--|----------------------|-----|-----|----------------------|-----|-----|----------------------|------|-----|------|
| | | MIN | TYP | MAX | MIN | TYP | MAX | MIN | TYP | MAX | |
| t_{PLH} | Propagation delay time, low-to-high output From (input) A or B to (output) B or A | | 1.1 | | | 0.9 | | | 0.45 | | ns |
| t_{PHL} | Propagation delay time, high-to-low output From (input) A or B to (output) B or A | | 1.3 | | | 1.1 | | | 0.6 | | |

6.10 Typical Characteristics

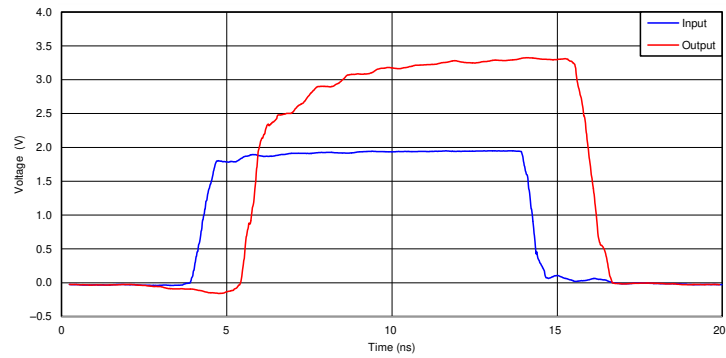
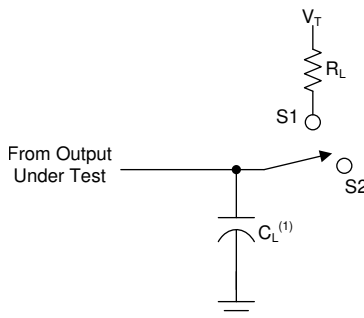

Figure 6-1. Signal Integrity (1.8 to 3.3 V Translation Up at 50 MHz)

Parameter Measurement Information

The outputs are measured one at a time, with one transition per measurement. All input pulses are supplied by generators that have the following characteristics:

- PRR ≤ 10 MHz
- $Z_O = 50 \Omega$
- $t_r \leq 2 \text{ ns}$
- $t_f \leq 2 \text{ ns}$



A. C_L includes probe and jig capacitance.

Figure 7-1. Load Circuit

| USAGE | SWITCH |
|------------------|--------|
| Translating Up | S1 |
| Translating Down | S2 |

Figure 7-2. Translating Up and Down Table

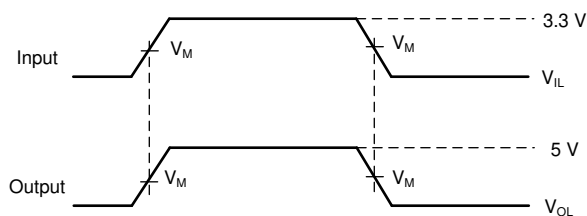

Figure 7-3. Translating Up

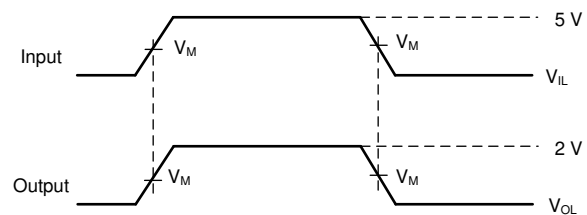

Figure 7-4. Translating Down

7 Detailed Description

7.1 Overview

The LSF0102-Q1 device can be used in level translation applications for interfacing devices or systems operating at different interface voltages. The LSF0102-Q1 device is ideal for use in applications where an open-drain driver is connected to the data I/Os. With appropriate pull-up resistors and layout, the LSF0102-Q1 device can achieve 100 MHz. The LSF0102-Q1 can also be used in applications where a push-pull driver is connected to the data I/Os.

7.2 Functional Block Diagrams

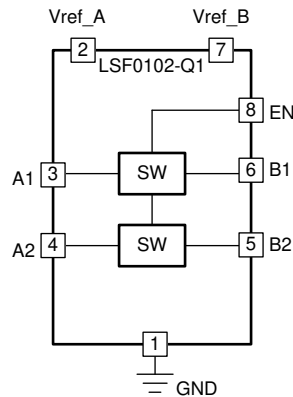

Figure 7-1. LSF0102-Q1 Functional Block Diagram

7.3 Feature Description

7.3.1 Auto Bidirectional Voltage Translation

The LSF0102-Q1 device is an auto bidirectional voltage level translator that operates from 0.95 to 4.5 V on Vref_A and 1.8 to 5.5 V on Vref_B. This allows bidirectional voltage translation between 0.95 V and 5.5 V without the need for a direction pin in open-drain or push-pull applications. The LSF0102-Q1 device supports level translation applications with transmission speeds greater than 100 Mbps for open-drain systems using a 250-Ω pullup resistor with a 30-pF capacitive load.

7.3.2 Output Enable

When EN is HIGH, the translator switch is on, and the An I/O is connected to the Bn I/O, respectively, allowing bidirectional data flow between ports. When EN is LOW, the translator switch is off, and a high-impedance state exists between ports. To enable the I/O pins, the EN input should be tied directly to Vref_B. To ensure the high-impedance state during power-up or power-down, EN must be LOW. For additional details on how to use the enable pin, see the [Using the Enable Pin with the LSF Family](#) video.

Table 7-1. Enable Function Table

| INPUT EN ⁽¹⁾ PIN | FUNCTION |
|-----------------------------|----------|
| Tied directly to Vref_B | An = Bn |
| L | Hi-Z |

(1) EN is controlled by Vref_B logic levels and should be at least 1 V higher than Vref_A for best translator.

7.3.3 Mixed-Mode Voltage Translation

The supply voltage (Vpu#) for each channel can be individually set up with a pull-up resistor. For example, CH1 can be used in up-translation mode (1.2 V ↔ 3.3 V) and CH2 in down-translation mode (2.5 V ↔ 1.8 V). For additional details on how to use the LSF0102-Q1 for mixed-mode voltage translation, see the [Multi-Voltage Translation with the LSF Family](#) video.

7.4 Device Functional Modes

When the An or Bn port is LOW, the switch is in the ON-state and a low resistance connection exists between the An and Bn ports. The low R_{on} of the switch allows connections to be made with minimal propagation delay and signal distortion. Assuming the higher voltage is on the Bn port when the Bn port is HIGH, the voltage on the An port is limited to the voltage set by Vref_A. When the An port is HIGH, the Bn port is pulled to the drain pull-up supply voltage ($V_{pu\#}$) by the pull-up resistors. This functionality allows a seamless translation between higher and lower voltages selected by the user without the need for direction control. For additional details on the functional operation of the LSF0102-Q1, see the [Down Translation with the LSF Family](#) and [Up Translation with the LSF Family](#) videos.

8 Application and Implementation

Note

Information in the following applications sections is not part of the TI component specification, and TI does not warrant its accuracy or completeness. TI's customers are responsible for determining suitability of components for their purposes, as well as validating and testing their design implementation to confirm system functionality.

8.1 Application Information

The LSF0102-Q1 device is able to perform voltage translation for open-drain or push-pull interfaces such as I²C, SPI, UART, MDIO, SDIO, and GPIO.

8.2 Typical Application

8.2.1 Bidirectional Translation

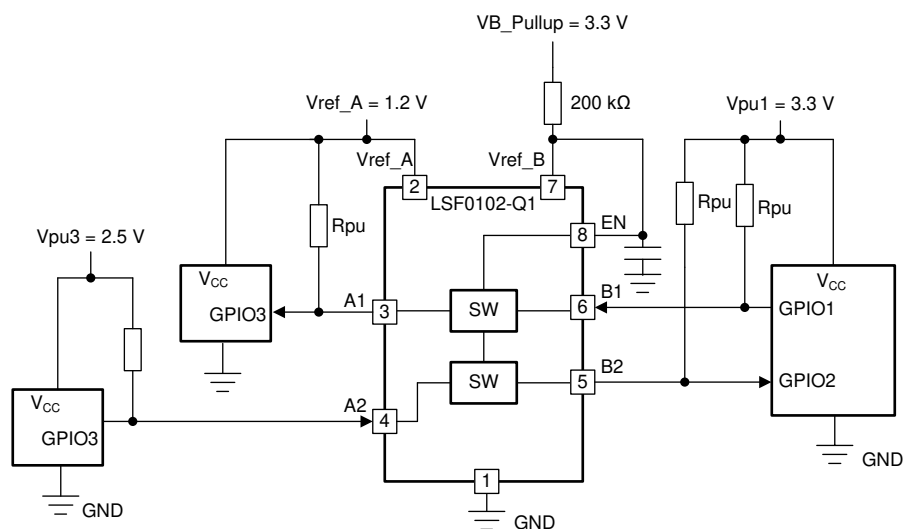

Figure 8-1. Bidirectional Translation to Multiple Voltage Levels

8.2.1.1 Design Requirements

8.2.1.1.1 Enable, Disable, and Reference Voltage Guidelines

The LSF0102-Q1 device has an EN input that is used to disable the device by setting EN LOW, which places all I/Os in the high-impedance state. Since LSF family is switch-type voltage translator, the power consumption is very low. It is recommended to always enable LSF0102-Q1 device for bidirectional applications by connecting the EN pin to the Vref_B pin, as shown in [Figure 8-1](#). For additional details on setting up the Vref_A, Vref_B, and EN pins, see the [Understanding the Bias Circuit for the LSF Family](#) video.

Table 8-1. Application Operating Condition

| PARAMETER | | MIN | TYP | MAX | UNIT |
|-----------------------|-------------------------|--------------|--------|--------|------|
| Vref_A ⁽¹⁾ | reference voltage (A) | 0.95 | | 4.5 | V |
| Vref_B | reference voltage (B) | Vref_A + 0.8 | | 5.5 | V |
| V _{I(EN)} | input voltage on EN pin | Vref_A + 0.8 | Vref_B | 5.5 | V |
| V _{pu} | pull-up supply voltage | 0 | | Vref_B | V |

(1) Vref_A is required to be the lowest voltage level across all inputs and outputs.

The 200 kΩ, pull-up resistor is required to allow Vref_B to regulate the EN input. A filter capacitor on Vref_B is recommended. Also Vref_B and V_{I(EN)} are recommended to be 1.0 V higher than Vref_A for best signal integrity.

8.2.1.2 Detailed Design Procedure

8.2.1.2.1 Bidirectional Translation

For the bidirectional clamping configuration (higher voltage to lower voltage or lower voltage to higher voltage), the EN input must be connected to Vref_B and both pins pulled to HIGH side V_{pu} through a pull-up resistor (typically 200 kΩ), as shown in [Figure 8-1](#). This allows Vref_B to regulate the EN input. A filter capacitor on Vref_B is recommended. The controller output driver can be push-pull or open-drain (pull-up resistors may be required) and the peripheral device output can be push-pull or open-drain (pull-up resistors are required to pull the Bn outputs to V_{pu}).

If either output is push-pull, data must be unidirectional or the outputs must be tri-state and be controlled by some direction-control mechanism to prevent HIGH-to-LOW contention in either direction. If both outputs are open-drain, no direction control is needed.

In [Figure 8-1](#), the reference supply voltage (Vref_A) is connected to the processor core power supply voltage. When Vref_B is connected through a 200 kΩ resistor to a 3.3 V V_{pu} power supply, and Vref_A is set 1.2 V. The output of A1 has a maximum output voltage equal to Vref_A, and the bidirectional interface on channel 2 has a maximum output voltage equal to V_{pu}.

8.2.1.2.2 Pull-up Resistor Sizing

To maintain an appropriate output low voltage, the pull-up resistor value should limit the current through the pass transistor when it is in the ON state to less than 15 mA. This ensures a pass voltage of 260 mV to 350 mV. To set the current through each pass transistor at 15 mA, the pull-up resistor value can be calculated using the following equation:

$$R_{pu} = (V_{pu} - 0.35 \text{ V}) / 0.015 \text{ A} \tag{1}$$

The appropriate pull up resistor will depend on the current requirements of the application. [Table 8-2](#) summarizes resistor values, reference voltages, and currents at 15 mA, 10 mA, and 3 mA. The resistor value shown in the +10% column (or a larger value) should be used to ensure that the pass voltage of the transistor is 350 mV or less. The external driver must be able to sink the total current from the resistors on both sides of the LSF0102-Q1 device at 0.175 V, although the 15 mA applies only to current flowing through the LSF0102-Q1.

Table 8-2. Pull-up Resistor Values

| V _{DPU} | 15 mA | | 10 mA | | 3 mA | |
|------------------|-------------|-------------------------|-------------|-------------------------|-------------|-------------------------|
| | NOMINAL (Ω) | +10% ⁽¹⁾ (Ω) | NOMINAL (Ω) | +10% ⁽¹⁾ (Ω) | NOMINAL (Ω) | +10% ⁽¹⁾ (Ω) |
| 5 V | 310 | 341 | 465 | 512 | 1550 | 1705 |
| 3.3 V | 197 | 217 | 295 | 325 | 983 | 1082 |
| 2.5 V | 143 | 158 | 215 | 237 | 717 | 788 |
| 1.8 V | 97 | 106 | 145 | 160 | 483 | 532 |
| 1.5 V | 77 | 85 | 115 | 127 | 383 | 422 |
| 1.2 V | 57 | 63 | 85 | 94 | 283 | 312 |

(1) +10% to compensate for V_{DD} range and resistor tolerance

8.2.1.3 Application Curve

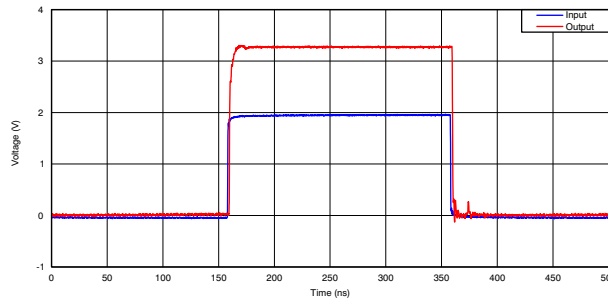

Figure 8-2. Captured Waveform From Above I²C Set-Up (1.8 V to 3.3 V at 2.5 MHz)

9 Power Supply Recommendations

There are no power sequence requirements for the LSF family. For recommended operating voltages for all supply and input pins, see [Table 9-1](#).

Table 9-1. Recommended Operating Voltages

| PARAMETER | | MIN | TYP | MAX | UNIT |
|-----------------------|-------------------------|--------------|-----|--------|------|
| Vref_A ⁽¹⁾ | reference voltage (A) | 0.95 | | 4.5 | V |
| Vref_B | reference voltage (B) | Vref_A + 0.8 | | 5.5 | V |
| V _{I(EN)} | input voltage on EN pin | Vref_A + 0.8 | | 5.5 | V |
| V _{pu} | pull-up supply voltage | 0 | | Vref_B | V |

10 Layout

10.1 Layout Guidelines

Because the LSF0102-Q1 device is a switch-type level translator, the signal integrity is dependent upon the pull-up resistor value and PCB board parasitics. Consider the following recommendations when designing with the LSF0102-Q1.

- Minimize the signal trace length to reduce capacitance
- Avoid using stubs in the signal path to reduce parasitics.
- Place the LSF0102-Q1 device near the high voltage side.
- Select the appropriate pull-up resistor that applies to translation levels and driving capability of transmitter.

10.2 Layout Example

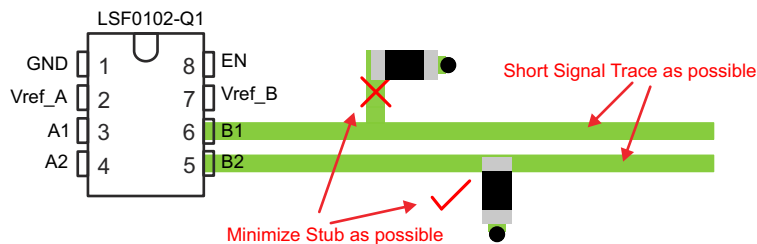

Figure 10-1. Short Trace Layout

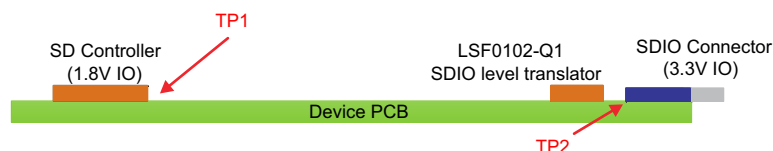

Figure 10-2. Device Placement

11 Device and Documentation Support

11.1 Documentation Support

11.1.1 Related Documentation

For related documentation see the following:

- Texas Instruments, [TI Logic Minute: Introduction – Voltage Level Translation with the LSF Family](#) video
- Texas Instruments, [Voltage-Level Translation with the LSF Family](#) application report

11.2 Receiving Notification of Documentation Updates

To receive notification of documentation updates, navigate to the device product folder on [ti.com](#). Click on *Subscribe to updates* to register and receive a weekly digest of any product information that has changed. For change details, review the revision history included in any revised document.

11.3 Support Resources

[TI E2E™ support forums](#) are an engineer's go-to source for fast, verified answers and design help — straight from the experts. Search existing answers or ask your own question to get the quick design help you need.

Linked content is provided "AS IS" by the respective contributors. They do not constitute TI specifications and do not necessarily reflect TI's views; see TI's [Terms of Use](#).

11.4 Trademarks

TI E2E™ is a trademark of Texas Instruments.

All trademarks are the property of their respective owners.

11.5 Electrostatic Discharge Caution



This integrated circuit can be damaged by ESD. Texas Instruments recommends that all integrated circuits be handled with appropriate precautions. Failure to observe proper handling and installation procedures can cause damage.

ESD damage can range from subtle performance degradation to complete device failure. Precision integrated circuits may be more susceptible to damage because very small parametric changes could cause the device not to meet its published specifications.

11.6 Glossary

[TI Glossary](#) This glossary lists and explains terms, acronyms, and definitions.

12 Mechanical, Packaging, and Orderable Information

The following pages include mechanical, packaging, and orderable information. This information is the most current data available for the designated devices. This data is subject to change without notice and revision of this document. For browser-based versions of this data sheet, refer to the left-hand navigation.

PACKAGING INFORMATION

| Orderable Device | Status (1) | Package Type | Package Drawing | Pins | Package Qty | Eco Plan (2) | Lead finish/ Ball material (6) | MSL Peak Temp (3) | Op Temp (°C) | Device Marking (4/5) | Samples |
|------------------|---------------|--------------|-----------------|------|-------------|-----------------|--------------------------------------|----------------------|--------------|-------------------------|---------|
| LSF0102QDCURQ1 | ACTIVE | VSSOP | DCU | 8 | 3000 | RoHS & Green | NIPDAUAG | Level-2-260C-1 YEAR | -40 to 125 | NG2SQ | Samples |

(1) The marketing status values are defined as follows:

ACTIVE: Product device recommended for new designs.

LIFEBUY: TI has announced that the device will be discontinued, and a lifetime-buy period is in effect.

NRND: Not recommended for new designs. Device is in production to support existing customers, but TI does not recommend using this part in a new design.

PREVIEW: Device has been announced but is not in production. Samples may or may not be available.

OBSOLETE: TI has discontinued the production of the device.

(2) **RoHS:** TI defines "RoHS" to mean semiconductor products that are compliant with the current EU RoHS requirements for all 10 RoHS substances, including the requirement that RoHS substance do not exceed 0.1% by weight in homogeneous materials. Where designed to be soldered at high temperatures, "RoHS" products are suitable for use in specified lead-free processes. TI may reference these types of products as "Pb-Free".

RoHS Exempt: TI defines "RoHS Exempt" to mean products that contain lead but are compliant with EU RoHS pursuant to a specific EU RoHS exemption.

Green: TI defines "Green" to mean the content of Chlorine (Cl) and Bromine (Br) based flame retardants meet JS709B low halogen requirements of <=1000ppm threshold. Antimony trioxide based flame retardants must also meet the <=1000ppm threshold requirement.

(3) MSL, Peak Temp. - The Moisture Sensitivity Level rating according to the JEDEC industry standard classifications, and peak solder temperature.

(4) There may be additional marking, which relates to the logo, the lot trace code information, or the environmental category on the device.

(5) Multiple Device Markings will be inside parentheses. Only one Device Marking contained in parentheses and separated by a "-" will appear on a device. If a line is indented then it is a continuation of the previous line and the two combined represent the entire Device Marking for that device.

(6) Lead finish/Ball material - Orderable Devices may have multiple material finish options. Finish options are separated by a vertical ruled line. Lead finish/Ball material values may wrap to two lines if the finish value exceeds the maximum column width.

Important Information and Disclaimer:The information provided on this page represents TI's knowledge and belief as of the date that it is provided. TI bases its knowledge and belief on information provided by third parties, and makes no representation or warranty as to the accuracy of such information. Efforts are underway to better integrate information from third parties. TI has taken and continues to take reasonable steps to provide representative and accurate information but may not have conducted destructive testing or chemical analysis on incoming materials and chemicals. TI and TI suppliers consider certain information to be proprietary, and thus CAS numbers and other limited information may not be available for release.

In no event shall TI's liability arising out of such information exceed the total purchase price of the TI part(s) at issue in this document sold by TI to Customer on an annual basis.

OTHER QUALIFIED VERSIONS OF LSF0102-Q1 :

- Catalog : [LSF0102](#)

NOTE: Qualified Version Definitions:

- Catalog - TI's standard catalog product

DCU (R-PDSO-G8)

PLASTIC SMALL-OUTLINE PACKAGE (DIE DOWN)

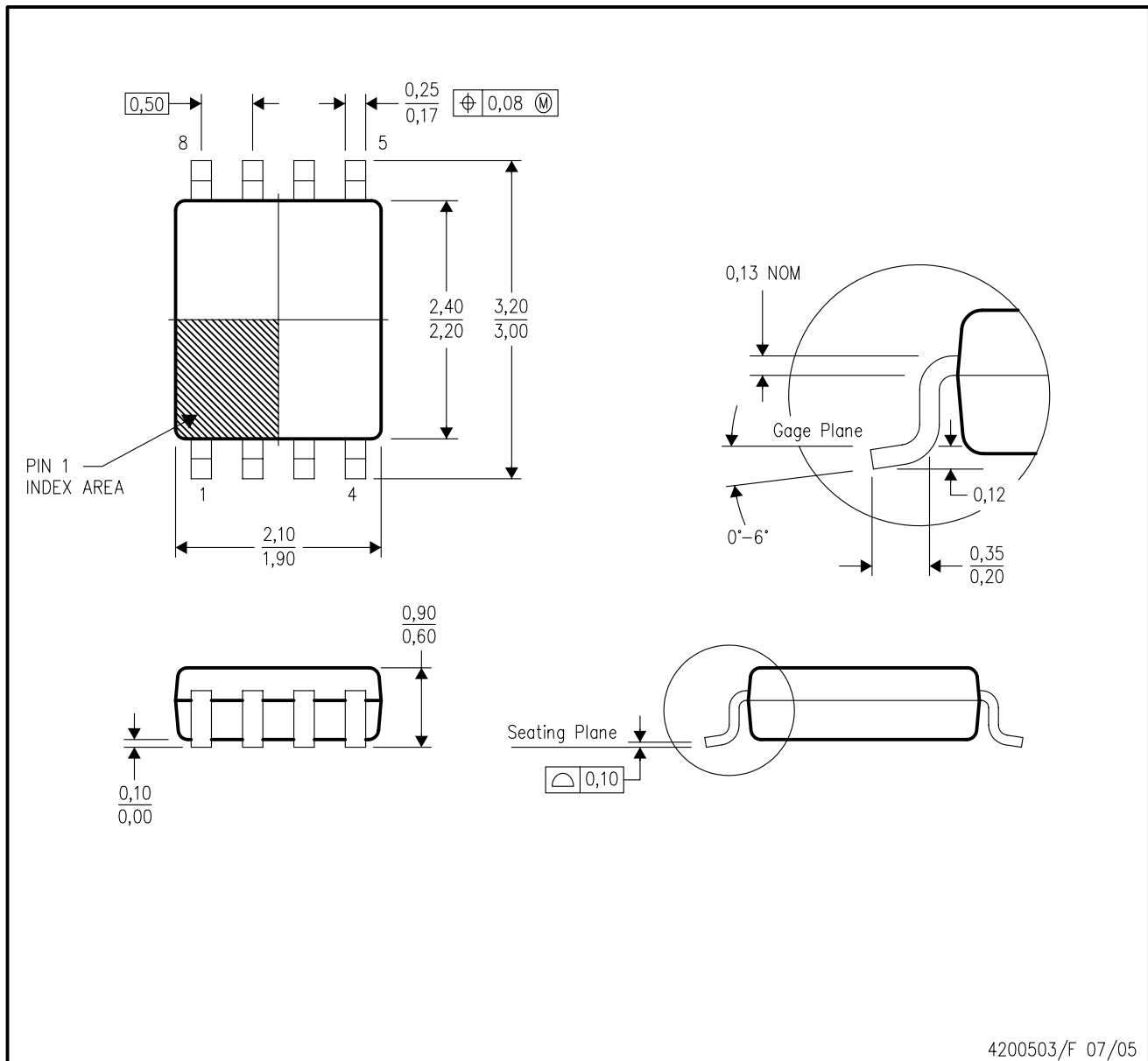

- NOTES:
- All linear dimensions are in millimeters.
 - This drawing is subject to change without notice.
 - Body dimensions do not include mold flash or protrusion. Mold flash and protrusion shall not exceed 0.15 per side.
 - Falls within JEDEC MO-187 variation CA.

IMPORTANT NOTICE AND DISCLAIMER

TI PROVIDES TECHNICAL AND RELIABILITY DATA (INCLUDING DATASHEETS), DESIGN RESOURCES (INCLUDING REFERENCE DESIGNS), APPLICATION OR OTHER DESIGN ADVICE, WEB TOOLS, SAFETY INFORMATION, AND OTHER RESOURCES "AS IS" AND WITH ALL FAULTS, AND DISCLAIMS ALL WARRANTIES, EXPRESS AND IMPLIED, INCLUDING WITHOUT LIMITATION ANY IMPLIED WARRANTIES OF MERCHANTABILITY, FITNESS FOR A PARTICULAR PURPOSE OR NON-INFRINGEMENT OF THIRD PARTY INTELLECTUAL PROPERTY RIGHTS.

These resources are intended for skilled developers designing with TI products. You are solely responsible for (1) selecting the appropriate TI products for your application, (2) designing, validating and testing your application, and (3) ensuring your application meets applicable standards, and any other safety, security, or other requirements. These resources are subject to change without notice. TI grants you permission to use these resources only for development of an application that uses the TI products described in the resource. Other reproduction and display of these resources is prohibited. No license is granted to any other TI intellectual property right or to any third party intellectual property right. TI disclaims responsibility for, and you will fully indemnify TI and its representatives against, any claims, damages, costs, losses, and liabilities arising out of your use of these resources.

TI's products are provided subject to TI's Terms of Sale (<https://www.ti.com/legal/termsofsale.html>) or other applicable terms available either on [ti.com](https://www.ti.com) or provided in conjunction with such TI products. TI's provision of these resources does not expand or otherwise alter TI's applicable warranties or warranty disclaimers for TI products.

Mailing Address: Texas Instruments, Post Office Box 655303, Dallas, Texas 75265
Copyright © 2021, Texas Instruments Incorporated