

MAX232E Dual RS-232 Driver and Receiver With IEC61000-4-2 Protection

1 Features

- Meets or exceeds TIA/RS-232-F and ITU recommendation V.28
- ESD Protection for RS-232 bus pins
 - ±15kV Human-body model (HBM)
 - ±8kV IEC61000-4-2, Contact discharge
 - ±15kV IEC61000-4-2, Air-gap discharge
- Operates from a single 5V power supply with 1μF charge-pump capacitors
- Operates up to 250kbit/s
- Two drivers and two receivers
- Low supply current: 8mA typical

2 Applications

- TIA/RS-232-F
- [Battery-powered systems](#)
- Terminals
- Modems
- Computers

3 Description

The MAX232E is a dual driver and receiver that includes a capacitive voltage generator to supply RS-232-F compliant voltage levels from a single 5V supply. Each receiver converts RS-232 inputs to 5V TTL/CMOS levels. This receiver has a typical threshold of 1.3V, a typical hysteresis of 0.5V, and can accept ±30V inputs. Each driver converts TTL/CMOS input levels into TIA/RS-232-F levels.

Package Information

PART NUMBER	PACKAGE ⁽¹⁾	PACKAGE SIZE ⁽²⁾
MAX232	SOIC (16)	9.9mm × 6mm
	SOIC (16)	10.4mm × 10.3mm
	PDIP (16)	19.3mm × 9mm
	SOP (16)	10.2mm × 7.8 mm

- (1) For more information, see [Section 10](#).
 (2) The package size (length × width) is a nominal value and includes pins, where applicable.

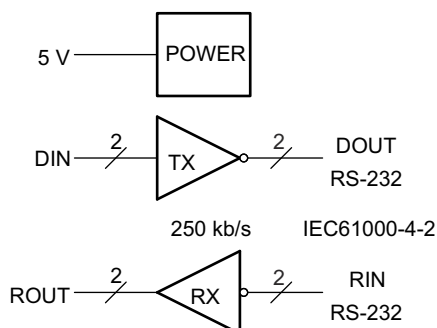

Copyright © 2016, Texas Instruments Incorporated

Logic Diagram (Positive Logic)



Table of Contents

1 Features	1	6.2 Functional Block Diagram.....	10
2 Applications	1	6.3 Feature Description.....	10
3 Description	1	6.4 Device Functional Modes.....	11
4 Pin Configuration and Functions	3	7 Applications and Implementation	12
5 Specifications	4	7.1 Application Information.....	12
5.1 Absolute Maximum Ratings.....	4	7.2 Typical Application.....	12
5.2 ESD Ratings.....	4	7.3 Power Supply Recommendations.....	13
5.3 Recommended Operating Conditions.....	4	7.4 Layout.....	14
5.4 Thermal Information.....	5	8 Device and Documentation Support	15
5.5 Electrical Characteristics.....	5	8.1 Receiving Notification of Documentation Updates....	15
5.6 Electrical Characteristics: Driver.....	5	8.2 Support Resources.....	15
5.7 Electrical Characteristics: Receiver.....	5	8.3 Trademarks.....	15
5.8 Switching Characteristics: Driver.....	6	8.4 Electrostatic Discharge Caution.....	15
5.9 Switching Characteristics: Receiver.....	6	8.5 Glossary.....	15
5.10 Typical Characteristics.....	7	9 Revision History	15
6 Detailed Description	10	10 Mechanical, Packaging, and Orderable Information	15
6.1 Overview.....	10		

4 Pin Configuration and Functions

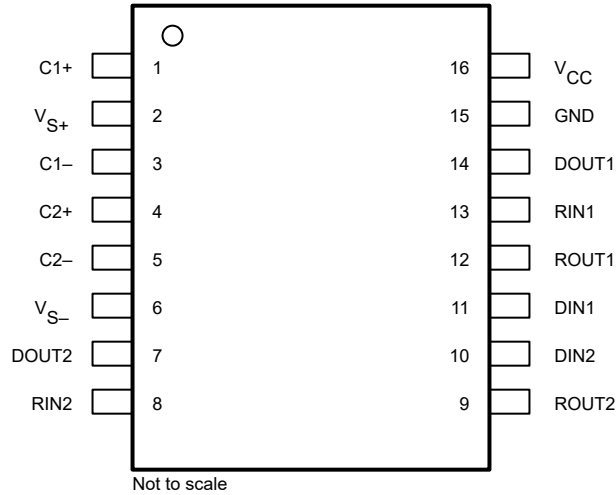

Figure 4-1. D (SOIC) , DW (SOIC) , N (PDIP), or PW (TSSOP) 16-Pin Package (Top View)

Table 4-1. Pin Functions

PIN		TYPE	DESCRIPTION
NO.	NAME		
1	C1+	—	Positive lead of C1 capacitor
2	VS+	O	Positive charge pump output for storage capacitor only
3	C1–	—	Negative lead of C1 capacitor
4	C2+	—	Positive lead of C2 capacitor
5	C2–	—	Negative lead of C2 capacitor
6	VS–	O	Negative charge pump output for storage capacitor only
7	DOUT2	O	RS-232 line data output (to remote RS-232 system)
8	RIN2	I	RS-232 line data input (from remote RS-232 system)
9	ROUT2	O	Logic data output (to UART)
10	DIN2	I	Logic data input (from UART)
11	DIN1	I	Logic data input (from UART)
12	ROUT1	O	Logic data output (to UART)
13	RIN1	I	RS-232 line data input (from remote RS-232 system)
14	DOUT1	O	RS-232 line data output (to remote RS-232 system)
15	GND	—	Ground
16	VCC	—	Supply voltage, connect to external 5V power supply

5 Specifications

5.1 Absolute Maximum Ratings

over operating free-air temperature range (unless otherwise noted)⁽¹⁾

		MIN	MAX	UNIT
V _{CC}	Input supply voltage ⁽²⁾	-0.3	6	V
V _{S+}	Positive output supply voltage	V _{CC} - 0.3	15	V
V _{S-}	Negative output supply voltage	-0.3	-15	V
V _I	Input voltage	Driver	V _{CC} + 0.3	V
		Receiver	±30	
V _O	Output voltage	DOUT	V _{S-} - 0.3 V _{S+} + 0.3	V
		ROUT	-0.3 V _{CC} + 0.3	
	Short-circuit duration	DOUT		Unlimited
T _J	Operating virtual junction temperature		150	°C
T _{stg}	Storage temperature	-65	150	°C

- (1) Stresses beyond those listed under *Absolute Maximum Ratings* may cause permanent damage to the device. These are stress ratings only, which do not imply functional operation of the device at these or any other conditions beyond those indicated under *Recommended Operating Conditions*. Exposure to absolute-maximum-rated conditions for extended periods may affect device reliability.
- (2) All voltages are with respect to network GND.

5.2 ESD Ratings

			VALUE	UNIT	
V _(ESD)	Electrostatic discharge	Human-body model (HBM), per ANSI/ESDA/JEDEC JS-001 ⁽¹⁾	Pins 7, 8, 13, and 14	±15000	V
			Other pins	±3000	
		Charged-device model (CDM), per JEDEC specification JESD22-C101 ⁽²⁾	All pins	±1500	
		IEC61000-4-2, air-gap discharge	Pins 7, 8, 13, and 14	±15000	
		IEC61000-4-2, contact discharge		±8000	

- (1) JEDEC document JEP155 states that 500V HBM allows safe manufacturing with a standard ESD control process.
- (2) JEDEC document JEP157 states that 250V CDM allows safe manufacturing with a standard ESD control process.

5.3 Recommended Operating Conditions

		MIN	NOM	MAX	UNIT
V _{CC}	Supply voltage	4.5	5	5.5	V
V _{IH}	High-level input voltage (DIN1, DIN2)	2			V
V _{IL}	Low-level input voltage (DIN1, DIN2)			0.8	V
	Receiver input voltage (RIN1, RIN2)	±3		±30	V
T _A	Operating free-air temperature	MAX232EC	0	70	°C
		MAX232EI	-40	85	

5.4 Thermal Information

THERMAL METRIC ^{(1) (2) (3)}		D (SOIC)	DW (SOIC)	N (PDIP)	PW (TSSOP)	UNIT
		16 PINS	16 PINS	16 PINS	16 PINS	
R _{θJA}	Junction-to-ambient thermal resistance	84.6	73.4	60.6	107.5	°C/W
R _{θJC(top)}	Junction-to-case (top) thermal resistance	43.5	35.1	48.1	38.4	°C/W
R _{θJB}	Junction-to-board thermal resistance	43.2	38.3	40.6	53.7	°C/W
ψ _{JT}	Junction-to-top characterization parameter	10.4	9.4	27.5	3.2	°C/W
ψ _{JB}	Junction-to-board characterization parameter	42.8	37.7	40.3	53.1	°C/W

- (1) For more information about traditional and new thermal metrics, see the [Semiconductor and IC Package Thermal Metrics](#) application report.
- (2) Maximum power dissipation is a function of T_{J(max)}, R_{θJA}, and T_A. The maximum allowable power dissipation at any allowable ambient temperature is P_D = (T_{J(max)} – T_A)/R_{θJA}. Operating at the absolute maximum T_J of 150°C can affect reliability.
- (3) The package thermal impedance is calculated in accordance with JESD 51-7.

5.5 Electrical Characteristics

over recommended ranges of supply voltage and operating free-air temperature (unless otherwise noted) (see [Figure 7-1](#))

PARAMETER		TEST CONDITIONS ⁽¹⁾		MIN	TYP ⁽²⁾	MAX	UNIT
I _{CC}	Supply current	V _{CC} = 5.5 V	All outputs open, T _A = 25°C		8	10	mA

- (1) Test conditions are C1 – C4 = 1μF at V_{CC} = 5V ± 0.5V.
- (2) All typical values are at V_{CC} = 5 V and T_A = 25°C.

5.6 Electrical Characteristics: Driver

over recommended ranges of supply voltage and operating free-air temperature range

PARAMETER		TEST CONDITIONS ⁽¹⁾		MIN	TYP ⁽²⁾	MAX	UNIT
V _{OH}	High-level output voltage	DOUT	R _L = 3 kΩ to GND	5	7		V
V _{OL}	Low-level output voltage ⁽³⁾	DOUT	R _L = 3 kΩ to GND		-7	-5	V
r _o	Output resistance	DOUT	V _{S+} = V _{S-} = 0, V _O = ±2 V	300			Ω
I _{OS} ⁽⁴⁾	Short-circuit output current	DOUT	V _{CC} = 5.5 V, V _O = 0		±10		mA
I _{IS}	Short-circuit input current	DIN	V _I = 0			200	μA

- (1) Test conditions are C1 – C4 = 1μF at V_{CC} = 5V ± 0.5V.
- (2) All typical values are at V_{CC} = 5V and T_A = 25°C.
- (3) The algebraic convention, in which the least-positive (most negative) value is designated minimum, is used in this data sheet for logic voltage levels only.
- (4) Not more than one output should be shorted at a time.

5.7 Electrical Characteristics: Receiver

over recommended ranges of supply voltage and operating free-air temperature range

PARAMETER		TEST CONDITIONS ⁽¹⁾		MIN	TYP ⁽²⁾	MAX	UNIT
V _{OH}	High-level output voltage	ROUT	I _{OH} = -1mA	3.5			V
V _{OL}	Low-level output voltage	ROUT	I _{OL} = 3.2mA			0.4	V
V _{IT+}	Receiver positive-going input threshold voltage	RIN	V _{CC} = 5V T _A = 25°C		1.7	2.4	V
V _{IT-}	Receiver negative-going input threshold voltage	RIN	V _{CC} = 5V T _A = 25°C	0.8	1.2		V
V _{hys}	Input hysteresis voltage	RIN	V _{CC} = 5V	0.2	0.5	1	V
r _i	Receiver input resistance	RIN	V _{CC} = 5V T _A = 25°C	3	5	7	kΩ

- (1) Test conditions are C1 – C4 = 1μF at V_{CC} = 5V ± 0.5V.
- (2) All typical values are at V_{CC} = 5V and T_A = 25°C.

5.8 Switching Characteristics: Driver

$V_{CC} = 5V$, $T_A = 25^\circ C$

PARAMETER		TEST CONDITIONS ⁽¹⁾	MIN	TYP	MAX	UNIT
SR	Driver slew rate	$R_L = 3k\Omega$ to $7k\Omega$, See Figure 6-2			30	V/ μ s
SR(t)	Driver transition region slew rate	$R_L = 3k\Omega$, $C_L = 2.5nF$ See Figure 6-3		3		V/ μ s
	Data rate	One DOUT switching		250		kbit/s

(1) Test conditions are $C1 - C4 = 1\mu F$ at $V_{CC} = 5V \pm 0.5V$.

5.9 Switching Characteristics: Receiver

$V_{CC} = 5V$, $T_A = 25^\circ C$ (see [Figure 6-1](#))

PARAMETER		TEST CONDITIONS ⁽¹⁾	TYP	UNIT
$t_{PLH(R)}$	Receiver propagation delay time, low- to high-level output	$C_L = 50pF$	500	ns
$t_{PHL(R)}$	Receiver propagation delay time, high- to low-level output	$C_L = 50pF$	500	ns

(1) Test conditions are $C1 - C4 = 1\mu F$ at $V_{CC} = 5V \pm 0.5V$.

5.10 Typical Characteristics

T_A = 25 °C

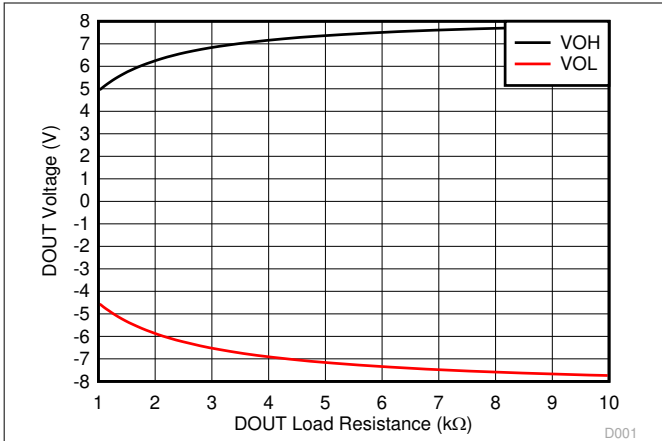

Figure 5-1. Driver Output Voltage vs Load Resistance

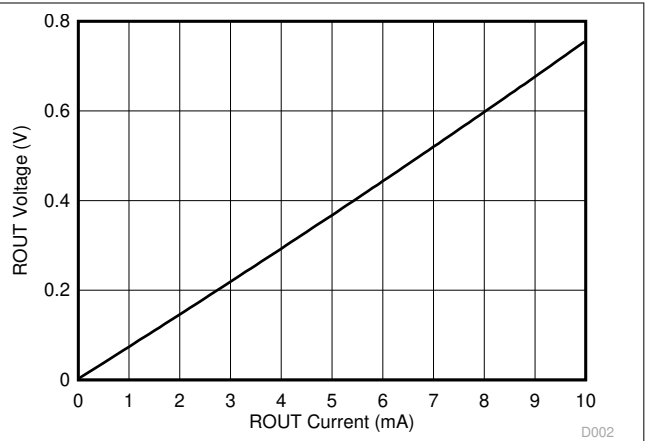

Figure 5-2. Receiver Low Output Voltage vs Load Current

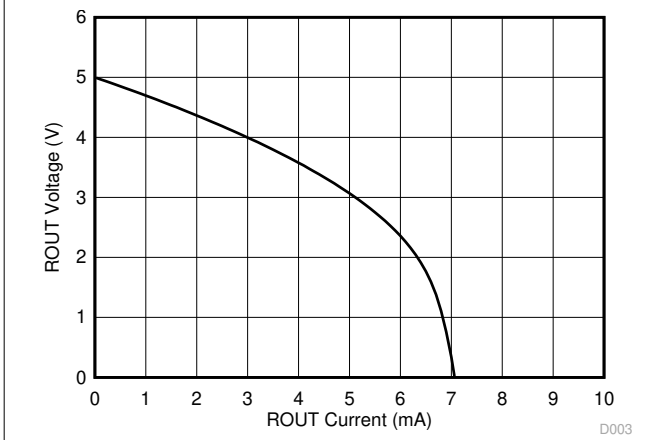

Figure 5-3. Receiver High Output Voltage vs Load Current

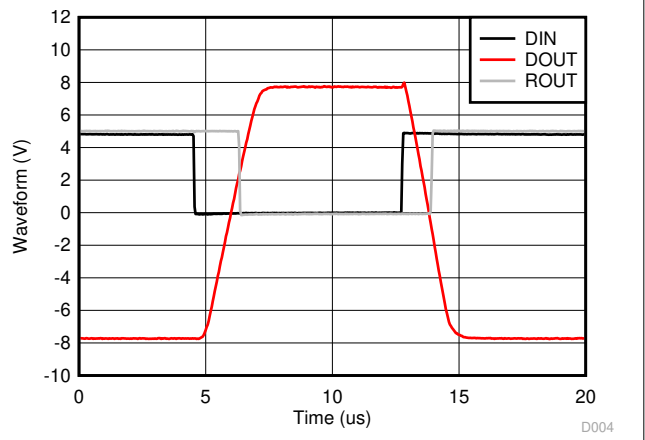
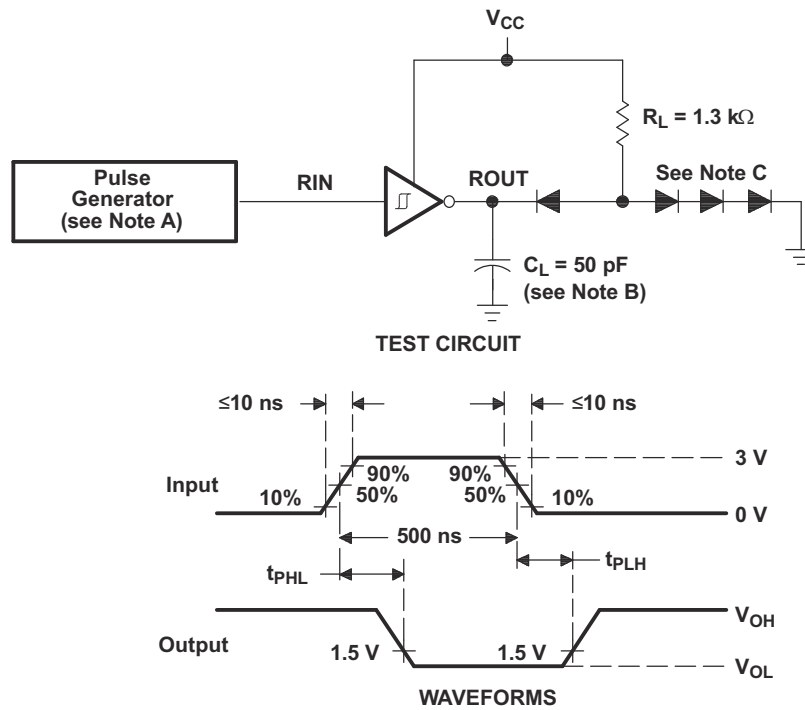
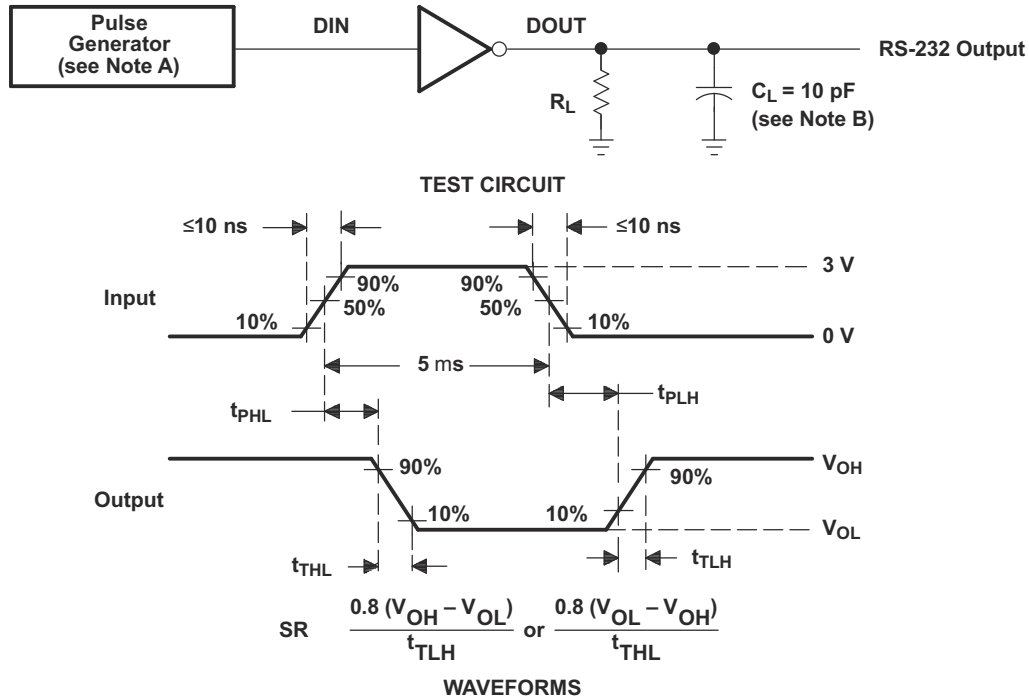

Figure 5-4. Loopback Waveforms Data Rate 120 kbit/s



- A. The pulse generator has the following characteristics: $Z_O = 50\Omega$, duty cycle $\leq 50\%$.
- B. C_L includes probe and jig capacitance.
- C. All diodes are 1N3064 or equivalent.

Figure 6-1. Receiver Test Circuit and Waveforms for t_{PHL} and t_{PLH} Measurements



- A. The pulse generator has the following characteristics: $Z_O = 50 \Omega$, duty cycle $\leq 50\%$.
- B. C_L includes probe and jig capacitance.

Figure 6-2. Driver Test Circuit and Waveforms for t_{PHL} and t_{PLH} Measurements (5- μs Input)

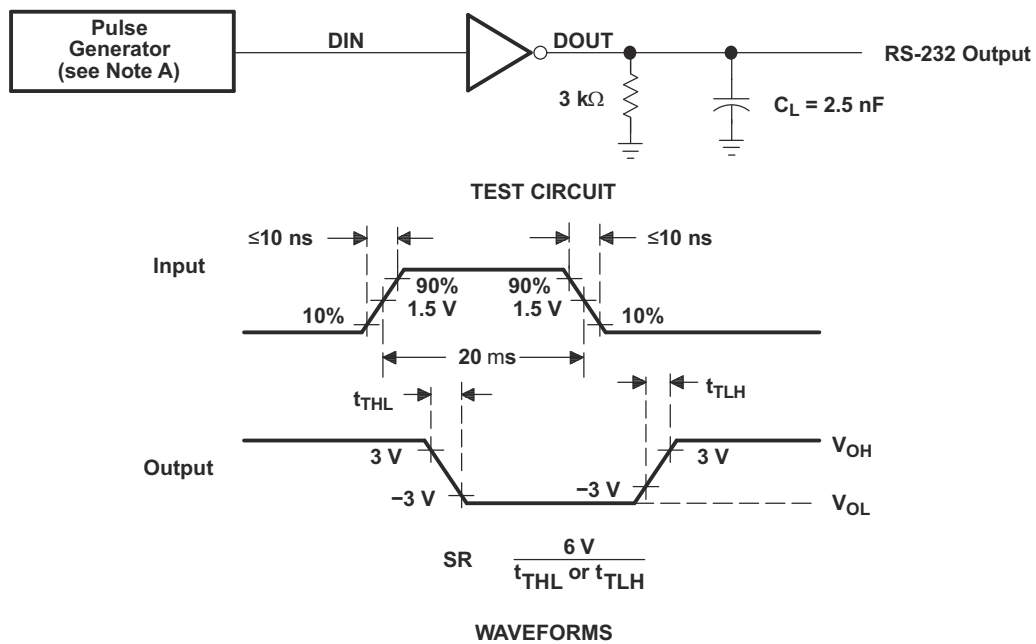

- A. The pulse generator has the following characteristics: $Z_O = 50 \Omega$, duty cycle $\leq 50\%$.

Figure 6-3. Test Circuit and Waveforms for t_{THL} and t_{TLH} Measurements (20- μs Input)

6 Detailed Description

6.1 Overview

The MAX232E is a dual driver and receiver that includes a capacitive voltage generator using four capacitors to supply TIA/EIA-232-F voltage levels from a single 5V supply. All RS-232 pins have 15kV HBM and IEC61000-4-2 Air-Gap discharge protection. RS-232 pins also have 8kV IEC61000-4-2 contact discharge protection. Each receiver converts TIA/EIA-232-F inputs to 5V TTL/CMOS levels. These receivers have shorted and open fail safe. The receiver can accept up to $\pm 30\text{V}$ inputs and decode inputs as low as $\pm 3\text{V}$. Each driver converts TTL/CMOS input levels into TIA/EIA-232-F levels. Outputs are protected against shorts to ground.

6.2 Functional Block Diagram

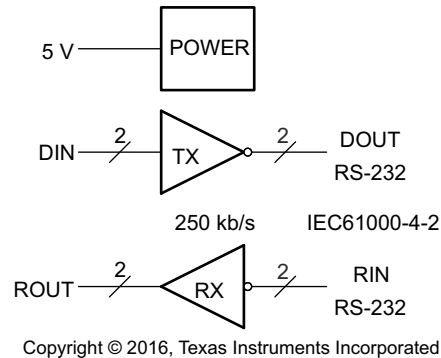

Figure 6-1. Logic Diagram (Positive Logic)

6.3 Feature Description

6.3.1 Power

The power block increases and inverts the 5V supply for the RS-232 driver using a charge pump that requires four $1\mu\text{F}$ external capacitors.

6.3.2 RS-232 Driver

Two drivers interface standard logic level to RS-232 levels. Internal pullup resistors on DIN inputs ensures a high input when the line is high impedance.

6.3.3 RS-232 Receiver

Two receivers interface RS-232 levels to standard logic levels. An open or shorted to ground input results in a high output on ROUT.

6.4 Device Functional Modes

6.4.1 V_{CC} Powered by 5V

The device is in normal operation.

6.4.2 V_{CC} Unpowered

When MAX232E is unpowered, it can be safely connected to an active remote RS-232 device.

6.4.3 Truth Tables

Table 6-1 and Table 6-2 list the functions of this device.

Table 6-1. Function Table for Each Driver

INPUT DIN ⁽¹⁾	OUTPUT DOUT
L	H
H	L

(1) H = high level, L = low level

Table 6-2. Function Table for Each Receiver

INPUT RIN ⁽¹⁾	OUTPUT ROUT
L	H
H	L
Open	H

(1) H = high level, L = low level, Open = input disconnected or connected driver off

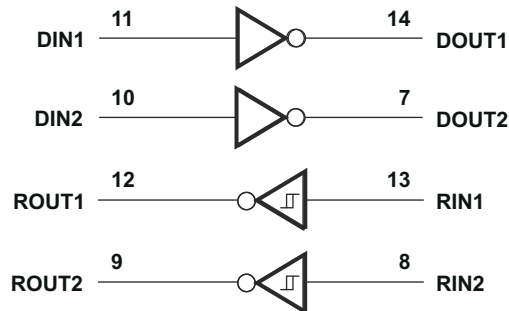

Figure 6-2. Logic Diagram (Positive Logic)

7 Applications and Implementation

Note

Information in the following applications sections is not part of the TI component specification, and TI does not warrant its accuracy or completeness. TI's customers are responsible for determining suitability of components for their purposes, as well as validating and testing their design implementation to confirm system functionality.

7.1 Application Information

For proper operation add capacitors as shown in Figure 7-1. Pins 9 through 12 connect to UART or general purpose logic lines. RS-232 lines on pins 7, 8, 13, and 14 connect to a connector or cable.

7.2 Typical Application

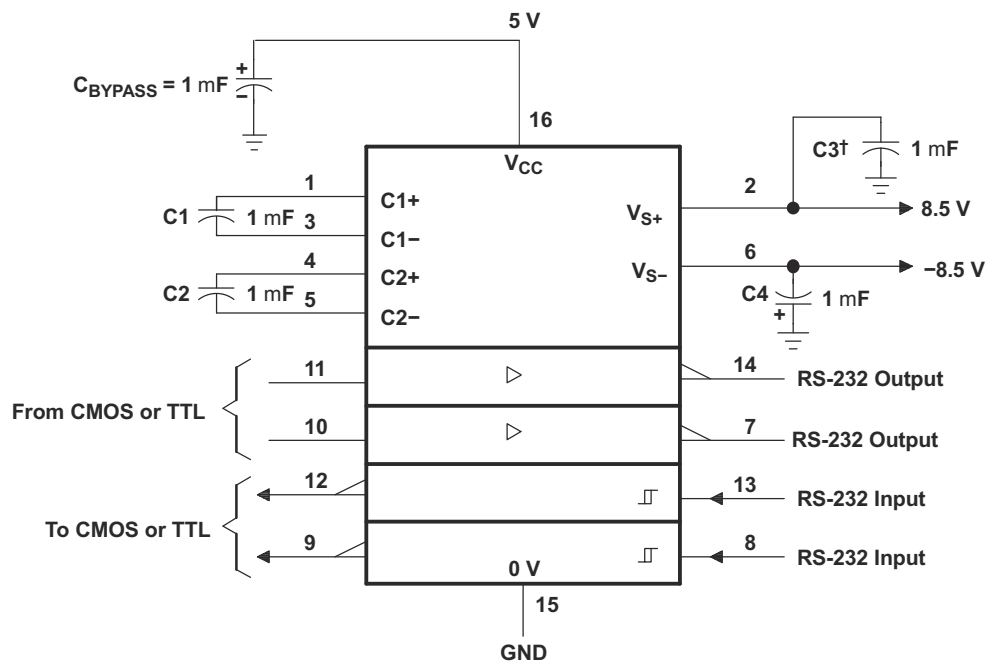

† C3 can be connected to V_{CC} or GND.

Copyright © 2016, Texas Instruments Incorporated

Resistor values shown are nominal.

Nonpolarized ceramic capacitors are acceptable. If polarized tantalum or electrolytic capacitors are used, they should be connected as shown.

Figure 7-1. Typical Operating Circuit

7.2.1 Design Requirements

- V_{CC} minimum is 4.5V and maximum is 5.5V.
- Maximum recommended bit rate is 250kbit/s.

7.2.2 Detailed Design Procedure

The capacitor type used for C1–C4 is not critical for proper operation. The MAX232E requires 1 μ F capacitors, although capacitors up to 10 μ F can be used without harm. Ceramic dielectrics are suggested for capacitors. When using the minimum recommended capacitor values, make sure the capacitance value does not degrade excessively as the operating temperature varies. If in doubt, use capacitors with a larger (for example, 2 \times) nominal value. The capacitors' effective series resistance (ESR), which usually rises at low temperatures, influences the amount of ripple on V+ and V–.

Use larger capacitors (up to 10 μ F) to reduce the output impedance at V_{S+} and V_{S–}.

Bypass V_{CC} to ground with at least 1 μ F. In applications sensitive to power-supply noise generated by the charge pumps, decouple V_{CC} to ground with a capacitor the same size as (or larger than) the charge-pump capacitors (C1–C4).

7.2.3 Application Curve

Loopback waveform connects DOUT to RIN.

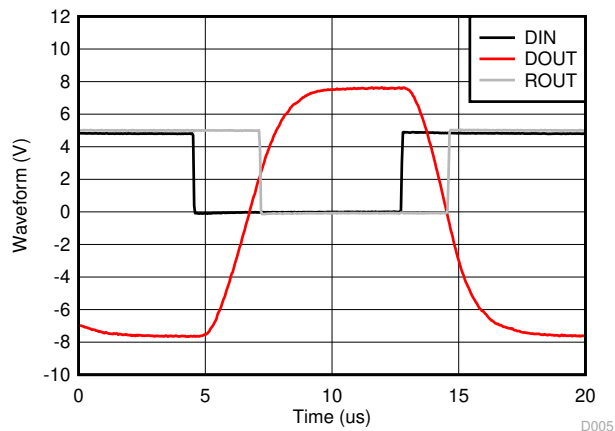

Date Rate = 120 kbit/s, C_L = 1 nF

Figure 7-2. Loopback Waveforms

7.3 Power Supply Recommendations

The V_{CC} voltage should be connected to the same power source used for logic device connected to DIN and ROUT pins. V_{CC} should be between 4.5V and 5.5V.

7.4 Layout

7.4.1 Layout Guidelines

Keep the external capacitor traces short. This is more important on C1 and C2 nodes that have the fastest rise and fall times. Make the impedance from MAX232E ground pin and circuit board ground plane as low as possible for best ESD performance. Use wide metal and multiple vias on both sides of ground pin.

7.4.2 Layout Example

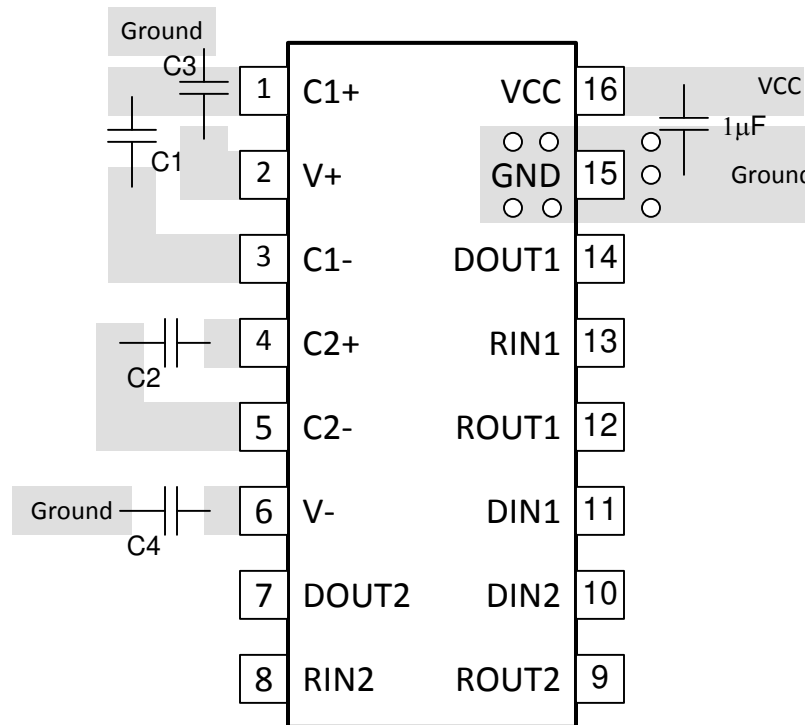

Figure 7-3. MAX232E Layout

8 Device and Documentation Support

8.1 Receiving Notification of Documentation Updates

To receive notification of documentation updates, navigate to the device product folder on ti.com. Click on *Subscribe to updates* to register and receive a weekly digest of any product information that has changed. For change details, review the revision history included in any revised document.

8.2 Support Resources

[TI E2E™ support forums](#) are an engineer's go-to source for fast, verified answers and design help — straight from the experts. Search existing answers or ask your own question to get the quick design help you need.

Linked content is provided "AS IS" by the respective contributors. They do not constitute TI specifications and do not necessarily reflect TI's views; see TI's [Terms of Use](#).

8.3 Trademarks

TI E2E™ is a trademark of Texas Instruments.
All trademarks are the property of their respective owners.

8.4 Electrostatic Discharge Caution



This integrated circuit can be damaged by ESD. Texas Instruments recommends that all integrated circuits be handled with appropriate precautions. Failure to observe proper handling and installation procedures can cause damage.

ESD damage can range from subtle performance degradation to complete device failure. Precision integrated circuits may be more susceptible to damage because very small parametric changes could cause the device not to meet its published specifications.

8.5 Glossary

[TI Glossary](#) This glossary lists and explains terms, acronyms, and definitions.

9 Revision History

NOTE: Page numbers for previous revisions may differ from page numbers in the current version.

Changes from Revision C (August 2016) to Revision D (February 2024)	Page
• Changed the Device Information table to the <i>Package Information</i> table.....	1
• Changed the <i>Thermal Information</i> table.....	5

Changes from Revision B (November 2009) to Revision C (August 2016)	Page
• Added <i>ESD Ratings</i> table, <i>Feature Description</i> section, <i>Device Functional Modes, Application and Implementation</i> section, <i>Power Supply Recommendations</i> section, <i>Layout</i> section, <i>Device and Documentation Support</i> section, and <i>Mechanical, Packaging, and Orderable Information</i> section	1
• Deleted "±30-V Input Levels" from <i>Features</i>	1
• Deleted <i>Ordering Information</i> table; see POA at the end of the data sheet	1
• Added MIN value ±3 to "Receiver input voltage (RIN1, RIN2) row in <i>Recommended Operating Conditions</i> ...	4
• Changed R _{θJA} values in <i>Thermal Information</i>	5
• Deleted table note 3 from <i>Receiver Section Electrical Characteristics</i>	5
• Added a new row to the <i>Function Table for Each Receiver</i>	11

10 Mechanical, Packaging, and Orderable Information

The following pages include mechanical, packaging, and orderable information. This information is the most current data available for the designated devices. This data is subject to change without notice and revision of this document. For browser-based versions of this data sheet, refer to the left-hand navigation.

PACKAGING INFORMATION

Orderable part number	Status (1)	Material type (2)	Package Pins	Package qty Carrier	RoHS (3)	Lead finish/ Ball material (4)	MSL rating/ Peak reflow (5)	Op temp (°C)	Part marking (6)
MAX232ECD	Obsolete	Production	SOIC (D) 16	-	-	Call TI	Call TI	0 to 70	MAX232EC
MAX232ECDR	Active	Production	SOIC (D) 16	2500 LARGE T&R	Yes	NIPDAU NIPDAU	Level-1-260C-UNLIM	0 to 70	MAX232EC
MAX232ECDW	Obsolete	Production	SOIC (DW) 16	-	-	Call TI	Call TI	0 to 70	MAX232EC
MAX232ECDWR	Obsolete	Production	SOIC (DW) 16	-	-	Call TI	Call TI	0 to 70	MAX232EC
MAX232ECDWRG4	Obsolete	Production	SOIC (DW) 16	-	-	Call TI	Call TI	0 to 70	MAX232EC
MAX232ECPW	Obsolete	Production	TSSOP (PW) 16	-	-	Call TI	Call TI	0 to 70	MA232EC
MAX232ECPWR	Obsolete	Production	TSSOP (PW) 16	-	-	Call TI	Call TI	0 to 70	MA232EC
MAX232ECPWRG4	Obsolete	Production	TSSOP (PW) 16	-	-	Call TI	Call TI	0 to 70	MA232EC
MAX232EID	Obsolete	Production	SOIC (D) 16	-	-	Call TI	Call TI	-40 to 85	MAX232EI
MAX232EIDR	Active	Production	SOIC (D) 16	2500 LARGE T&R	Yes	NIPDAU	Level-1-260C-UNLIM	-40 to 85	MAX232EI
MAX232EIDW	Obsolete	Production	SOIC (DW) 16	-	-	Call TI	Call TI	-40 to 85	MAX232EI
MAX232EIDWR	Active	Production	SOIC (DW) 16	2000 LARGE T&R	Yes	NIPDAU	Level-1-260C-UNLIM	-40 to 85	MAX232EI
MAX232EIN	Active	Production	PDIP (N) 16	25 TUBE	Yes	NIPDAU	N/A for Pkg Type	-40 to 85	MAX232EIN
MAX232EIPW	Obsolete	Production	TSSOP (PW) 16	-	-	Call TI	Call TI	-40 to 85	MB232EI
MAX232EIPWR	Active	Production	TSSOP (PW) 16	2000 LARGE T&R	Yes	NIPDAU	Level-1-260C-UNLIM	-40 to 85	MB232EI

(1) **Status:** For more details on status, see our [product life cycle](#).

(2) **Material type:** When designated, preproduction parts are prototypes/experimental devices, and are not yet approved or released for full production. Testing and final process, including without limitation quality assurance, reliability performance testing, and/or process qualification, may not yet be complete, and this item is subject to further changes or possible discontinuation. If available for ordering, purchases will be subject to an additional waiver at checkout, and are intended for early internal evaluation purposes only. These items are sold without warranties of any kind.

(3) **RoHS values:** Yes, No, RoHS Exempt. See the [TI RoHS Statement](#) for additional information and value definition.

(4) **Lead finish/Ball material:** Parts may have multiple material finish options. Finish options are separated by a vertical ruled line. Lead finish/Ball material values may wrap to two lines if the finish value exceeds the maximum column width.

(5) **MSL rating/Peak reflow:** The moisture sensitivity level ratings and peak solder (reflow) temperatures. In the event that a part has multiple moisture sensitivity ratings, only the lowest level per JEDEC standards is shown. Refer to the shipping label for the actual reflow temperature that will be used to mount the part to the printed circuit board.

(6) **Part marking:** There may be an additional marking, which relates to the logo, the lot trace code information, or the environmental category of the part.

Multiple part markings will be inside parentheses. Only one part marking contained in parentheses and separated by a "~" will appear on a part. If a line is indented then it is a continuation of the previous line and the two combined represent the entire part marking for that device.

Important Information and Disclaimer: The information provided on this page represents TI's knowledge and belief as of the date that it is provided. TI bases its knowledge and belief on information provided by third parties, and makes no representation or warranty as to the accuracy of such information. Efforts are underway to better integrate information from third parties. TI has taken and continues to take reasonable steps to provide representative and accurate information but may not have conducted destructive testing or chemical analysis on incoming materials and chemicals. TI and TI suppliers consider certain information to be proprietary, and thus CAS numbers and other limited information may not be available for release.

In no event shall TI's liability arising out of such information exceed the total purchase price of the TI part(s) at issue in this document sold by TI to Customer on an annual basis.

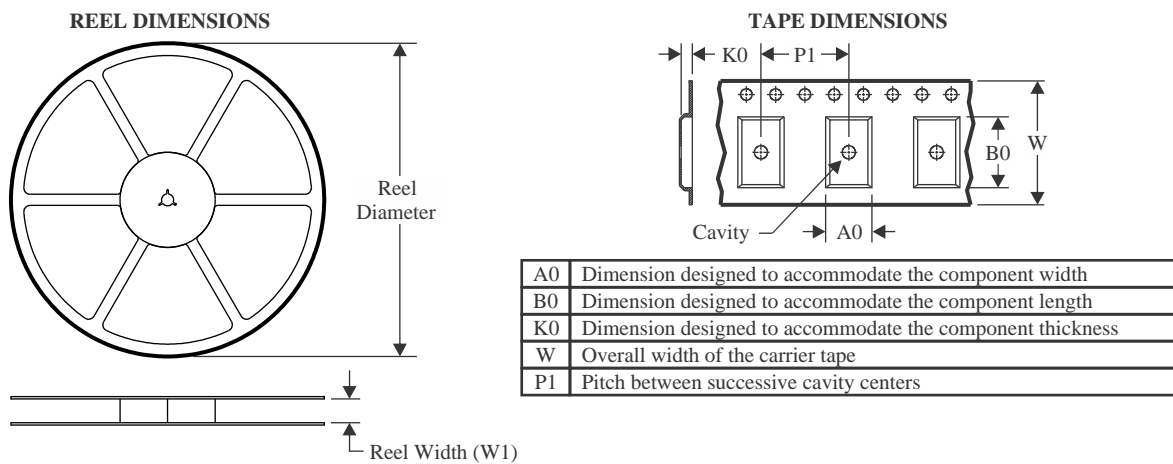
TAPE AND REEL INFORMATION

QUADRANT ASSIGNMENTS FOR PIN 1 ORIENTATION IN TAPE

*All dimensions are nominal

Device	Package Type	Package Drawing	Pins	SPQ	Reel Diameter (mm)	Reel Width W1 (mm)	A0 (mm)	B0 (mm)	K0 (mm)	P1 (mm)	W (mm)	Pin1 Quadrant
MAX232ECDR	SOIC	D	16	2500	330.0	16.4	6.5	10.3	2.1	8.0	16.0	Q1
MAX232ECDR	SOIC	D	16	2500	330.0	16.4	6.5	10.3	2.1	8.0	16.0	Q1
MAX232EIDR	SOIC	D	16	2500	330.0	16.4	6.5	10.3	2.1	8.0	16.0	Q1
MAX232EIDWR	SOIC	DW	16	2000	330.0	16.4	10.75	10.7	2.7	12.0	16.0	Q1
MAX232EIPWR	TSSOP	PW	16	2000	330.0	12.4	6.9	5.6	1.6	8.0	12.0	Q1
MAX232EIPWR	TSSOP	PW	16	2000	330.0	12.4	6.9	5.6	1.6	8.0	12.0	Q1

TAPE AND REEL BOX DIMENSIONS

*All dimensions are nominal

Device	Package Type	Package Drawing	Pins	SPQ	Length (mm)	Width (mm)	Height (mm)
MAX232ECDR	SOIC	D	16	2500	340.5	336.1	32.0
MAX232ECDR	SOIC	D	16	2500	333.2	345.9	28.6
MAX232EIDR	SOIC	D	16	2500	353.0	353.0	32.0
MAX232EIDWR	SOIC	DW	16	2000	350.0	350.0	43.0
MAX232EIPWR	TSSOP	PW	16	2000	356.0	356.0	35.0
MAX232EIPWR	TSSOP	PW	16	2000	353.0	353.0	32.0

TUBE

*All dimensions are nominal

Device	Package Name	Package Type	Pins	SPQ	L (mm)	W (mm)	T (μm)	B (mm)
MAX232EIN	N	PDIP	16	25	506	13.97	11230	4.32
MAX232EINE4	N	PDIP	16	25	506	13.97	11230	4.32

D (R-PDSO-G16)

PLASTIC SMALL OUTLINE



- NOTES:
- A. All linear dimensions are in inches (millimeters).
 - B. This drawing is subject to change without notice.
 - C. Body length does not include mold flash, protrusions, or gate burrs. Mold flash, protrusions, or gate burrs shall not exceed 0.006 (0,15) each side.
 - D. Body width does not include interlead flash. Interlead flash shall not exceed 0.017 (0,43) each side.
 - E. Reference JEDEC MS-012 variation AC.

PW0016A



PACKAGE OUTLINE

TSSOP - 1.2 mm max height

SMALL OUTLINE PACKAGE

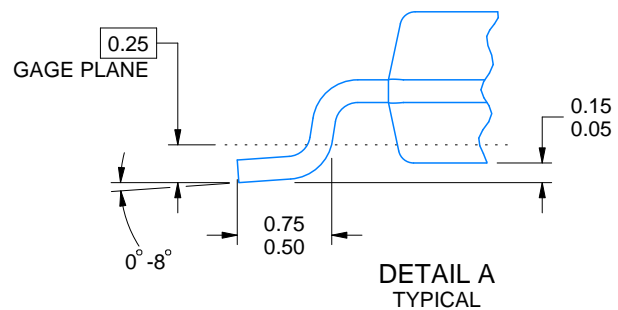
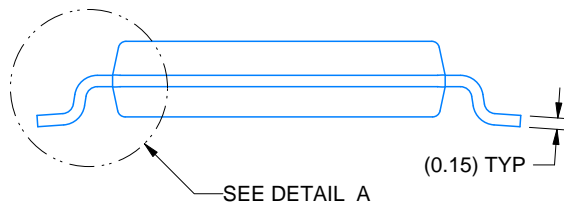
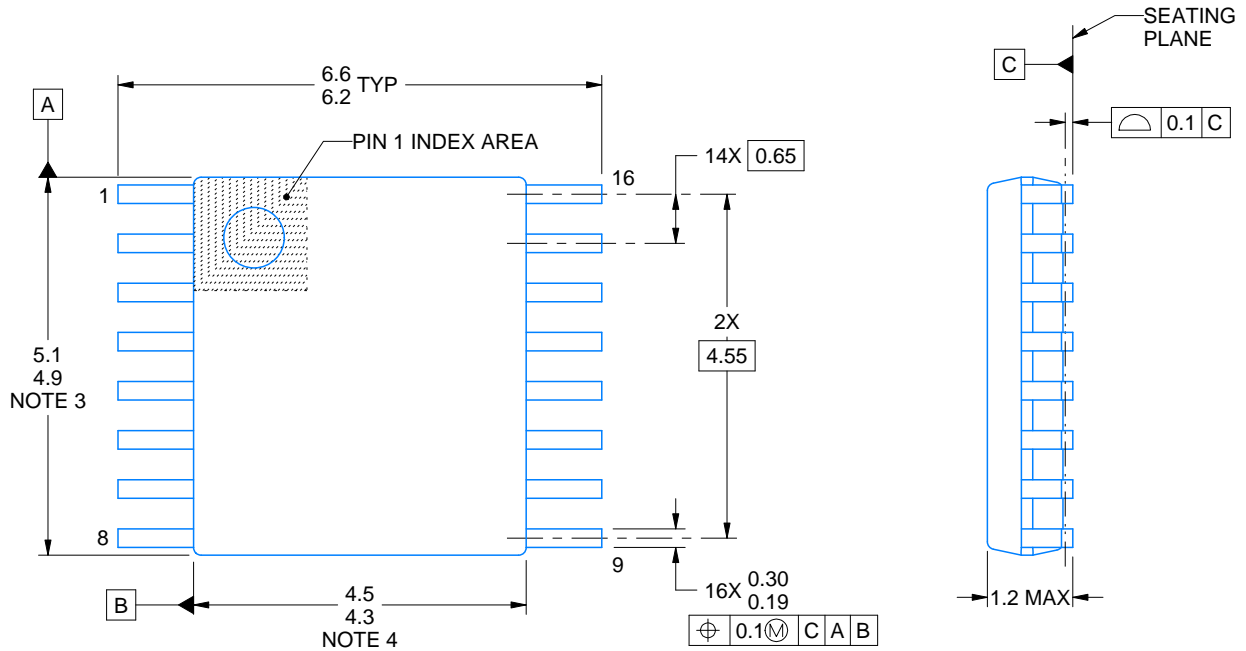

4220204/A 02/2017

NOTES:

1. All linear dimensions are in millimeters. Any dimensions in parenthesis are for reference only. Dimensioning and tolerancing per ASME Y14.5M.
2. This drawing is subject to change without notice.
3. This dimension does not include mold flash, protrusions, or gate burrs. Mold flash, protrusions, or gate burrs shall not exceed 0.15 mm per side.
4. This dimension does not include interlead flash. Interlead flash shall not exceed 0.25 mm per side.
5. Reference JEDEC registration MO-153.

EXAMPLE BOARD LAYOUT

PW0016A

TSSOP - 1.2 mm max height

SMALL OUTLINE PACKAGE



LAND PATTERN EXAMPLE
EXPOSED METAL SHOWN
SCALE: 10X



SOLDER MASK DETAILS

4220204/A 02/2017

NOTES: (continued)

- 6. Publication IPC-7351 may have alternate designs.
- 7. Solder mask tolerances between and around signal pads can vary based on board fabrication site.

EXAMPLE STENCIL DESIGN

PW0016A

TSSOP - 1.2 mm max height

SMALL OUTLINE PACKAGE



SOLDER PASTE EXAMPLE
BASED ON 0.125 mm THICK STENCIL
SCALE: 10X

4220204/A 02/2017

NOTES: (continued)

8. Laser cutting apertures with trapezoidal walls and rounded corners may offer better paste release. IPC-7525 may have alternate design recommendations.
9. Board assembly site may have different recommendations for stencil design.

GENERIC PACKAGE VIEW

DW 16

SOIC - 2.65 mm max height

7.5 x 10.3, 1.27 mm pitch

SMALL OUTLINE INTEGRATED CIRCUIT

This image is a representation of the package family, actual package may vary.
Refer to the product data sheet for package details.



4224780/A



DW0016A

PACKAGE OUTLINE SOIC - 2.65 mm max height

SOIC



NOTES:

1. All linear dimensions are in millimeters. Dimensions in parenthesis are for reference only. Dimensioning and tolerancing per ASME Y14.5M.
2. This drawing is subject to change without notice.
3. This dimension does not include mold flash, protrusions, or gate burrs. Mold flash, protrusions, or gate burrs shall not exceed 0.15 mm, per side.
4. This dimension does not include interlead flash. Interlead flash shall not exceed 0.25 mm, per side.
5. Reference JEDEC registration MS-013.

EXAMPLE BOARD LAYOUT

DW0016A

SOIC - 2.65 mm max height

SOIC



LAND PATTERN EXAMPLE
SCALE:7X



SOLDER MASK DETAILS

4220721/A 07/2016

NOTES: (continued)

6. Publication IPC-7351 may have alternate designs.

7. Solder mask tolerances between and around signal pads can vary based on board fabrication site.

EXAMPLE STENCIL DESIGN

DW0016A

SOIC - 2.65 mm max height

SOIC



SOLDER PASTE EXAMPLE
BASED ON 0.125 mm THICK STENCIL
SCALE:7X

4220721/A 07/2016

NOTES: (continued)

8. Laser cutting apertures with trapezoidal walls and rounded corners may offer better paste release. IPC-7525 may have alternate design recommendations.
9. Board assembly site may have different recommendations for stencil design.

N (R-PDIP-T**)

PLASTIC DUAL-IN-LINE PACKAGE

16 PINS SHOWN



- NOTES:
- A. All linear dimensions are in inches (millimeters).
 - B. This drawing is subject to change without notice.
 - Falls within JEDEC MS-001, except 18 and 20 pin minimum body length (Dim A).
 - The 20 pin end lead shoulder width is a vendor option, either half or full width.

IMPORTANT NOTICE AND DISCLAIMER

TI PROVIDES TECHNICAL AND RELIABILITY DATA (INCLUDING DATA SHEETS), DESIGN RESOURCES (INCLUDING REFERENCE DESIGNS), APPLICATION OR OTHER DESIGN ADVICE, WEB TOOLS, SAFETY INFORMATION, AND OTHER RESOURCES "AS IS" AND WITH ALL FAULTS, AND DISCLAIMS ALL WARRANTIES, EXPRESS AND IMPLIED, INCLUDING WITHOUT LIMITATION ANY IMPLIED WARRANTIES OF MERCHANTABILITY, FITNESS FOR A PARTICULAR PURPOSE OR NON-INFRINGEMENT OF THIRD PARTY INTELLECTUAL PROPERTY RIGHTS.

These resources are intended for skilled developers designing with TI products. You are solely responsible for (1) selecting the appropriate TI products for your application, (2) designing, validating and testing your application, and (3) ensuring your application meets applicable standards, and any other safety, security, regulatory or other requirements.

These resources are subject to change without notice. TI grants you permission to use these resources only for development of an application that uses the TI products described in the resource. Other reproduction and display of these resources is prohibited. No license is granted to any other TI intellectual property right or to any third party intellectual property right. TI disclaims responsibility for, and you will fully indemnify TI and its representatives against, any claims, damages, costs, losses, and liabilities arising out of your use of these resources.

TI's products are provided subject to [TI's Terms of Sale](#) or other applicable terms available either on [ti.com](https://www.ti.com) or provided in conjunction with such TI products. TI's provision of these resources does not expand or otherwise alter TI's applicable warranties or warranty disclaimers for TI products.

TI objects to and rejects any additional or different terms you may have proposed.

Mailing Address: Texas Instruments, Post Office Box 655303, Dallas, Texas 75265

Copyright © 2025, Texas Instruments Incorporated