

TMAG5328 Resistor and Voltage Adjustable, Low-Power Hall-Effect Switch

1 Features

- Supply Range of 1.65 V to 5.5 V
- Adjustable B_{OP} from 2 mT to 15 mT
 - Using 2-k Ω to 15-k Ω resistors
 - or 160-mV to 1200-mV voltage source
- Omnipolar Hall switch
- Push-Pull output
- Low power consumption
 - 20-Hz sampling rate: 1.4 μ A at 3.3 V
- Industry-standard package and pinout
 - SOT-23 package
- –40°C to 125°C operating temperature range

2 Applications

- Battery-critical position sensing
- Electricity meter tamper detection
- Cell phone, laptop, or tablet case sensing
- E-locks, smoke detectors, appliances
- Medical devices, IoT systems
- Valve or solenoid position detection
- Contactless diagnostics or activation

3 Description

The TMAG5328 device is a high precision, low-power, resistor adjustable Hall effect switch sensor operating at low voltage.

The external resistor sets the B_{OP} value the device will operate from. By following a simple formula, it is easy to calculate what resistor value is needed to set up the right B_{OP} value. The Hysteresis value is fixed and therefore the B_{RP} value is defined as B_{OP} -Hysteresis.

With this adjustable threshold feature, the TMAG5328 allows for easy and quick prototyping, fast design to market, reuse across different platforms and easy last minute modifications in case of unexpected changes.

When the applied magnetic flux density exceeds the B_{OP} threshold, the device outputs a low voltage. The output stays low until the flux density decreases to less than B_{RP} , and then the output drives a high voltage. By incorporating an internal oscillator, the device samples the magnetic field and updates the output at a rate of 20 Hz for the lowest current consumption. The TMAG5328 features an omnipolar magnetic response.

The device operates from a V_{CC} range of 1.65 V to 5.5 V, and is packaged in a standard SOT-23-6 package.

Device Information

PART NUMBER	PACKAGE ⁽¹⁾	BODY SIZE (NOM)
TMAG5328	SOT-23 (6)	2.92 mm × 1.30 mm

(1) For all available packages, see the orderable addendum at the end of the data sheet.

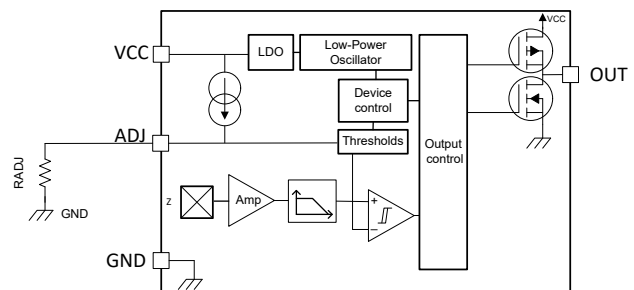

Typical Schematic

Table of Contents

1 Features	1	7.4 Device Functional Modes.....	13
2 Applications	1	8 Application and Implementation	14
3 Description	1	8.1 Application Information.....	14
4 Revision History	2	8.2 Typical Applications.....	19
5 Pin Configuration and Functions	3	9 Power Supply Recommendations	21
6 Specifications	4	10 Layout	21
6.1 Absolute Maximum Ratings.....	4	10.1 Layout Guidelines.....	21
6.2 ESD Ratings.....	4	10.2 Layout Examples.....	21
6.3 Recommended Operating Conditions.....	4	11 Device and Documentation Support	22
6.4 Thermal Information.....	5	11.1 Receiving Notification of Documentation Updates..	22
6.5 Electrical Characteristics.....	5	11.2 Support Resources.....	22
6.6 Magnetic Characteristics.....	6	11.3 Trademarks.....	22
6.7 Typical Characteristics.....	7	11.4 Electrostatic Discharge Caution.....	22
7 Detailed Description	9	11.5 Glossary.....	22
7.1 Overview.....	9	12 Mechanical, Packaging, and Orderable Information	22
7.2 Functional Block Diagram.....	9		
7.3 Feature Description.....	10		

4 Revision History

Changes from Revision * (December 2021) to Revision A (June 2022)	Page
• Changed data sheet status from: <i>Advanced Information</i> to: <i>Production Data</i>	1
• Added the FA and FD device versions.....	1

5 Pin Configuration and Functions

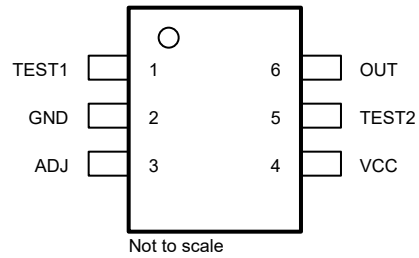

Figure 5-1. DBV Package 6-Pin SOT-23 Top View

Table 5-1. Pin Functions

PIN		I/O	DESCRIPTION
NAME	SOT-23		
GND	2	—	Ground reference
OUT	6	O	Omnipolar output that responds to north and south magnetic poles
VCC	4	—	1.65-V to 5.5-V power supply. TI recommends connecting this pin to a ceramic capacitor to ground with a value of at least 0.1 μ F
ADJ	3	I	This pin is used to set the thresholds up. Can either be connected to a resistor or voltage source.
TEST1	1	—	TI recommends to leave this pin floating
TEST2	5	—	TI recommends connecting this pin to GND

6 Specifications

6.1 Absolute Maximum Ratings

over operating free-air temperature range (unless otherwise noted)⁽¹⁾

		MIN	MAX	UNIT
Power Supply Voltage	V _{CC}	-0.3	5.5	V
Pin Voltage	OUT, TEST1	-0.3	V _{CC} + 0.3	V
	TEST2	-0.3	0.3	
	ADJ	-0.3	5.5	
Pin current	OUT, TEST1	-5	5	mA
Magnetic Flux Density, B _{MAX}		Unlimited		T
Junction temperature, T _J	Junction temperature, T _J		150	°C
Storage temperature, T _{stg}		-65	150	°C

- (1) Operation outside the Absolute Maximum Ratings may cause permanent device damage. Absolute Maximum Ratings do not imply functional operation of the device at these or any other conditions beyond those listed under Recommended Operating Conditions. If used outside the Recommended Operating Conditions but within the Absolute Maximum Ratings, the device may not be fully functional, and this may affect device reliability, functionality, performance, and shorten the device lifetime.

6.2 ESD Ratings

			VALUE	UNIT
V _(ESD)	Electrostatic discharge	Human body model (HBM), per ANSI/ESDA/ JEDEC JS-001, all pins ⁽¹⁾	±2000	V
		Charged device model (CDM), per ANSI/ESDA/ JEDEC JS-002, all pins ⁽²⁾	± 500	

- (1) JEDEC document JEP155 states that 500-V HBM allows safe manufacturing with a standard ESD control process.
 (2) JEDEC document JEP157 states that 250-V CDM allows safe manufacturing with a standard ESD control process.

6.3 Recommended Operating Conditions

over operating free-air temperature range (unless otherwise noted)

		MIN	MAX	UNIT
V _{CC}	Power supply voltage	1.65	5.5	V
V _{IO}	Pin Voltage. OUT, TEST1	0	V _{CC}	V
	Pin Voltage. TEST2	0	0	
	Pin Voltage. ADJ	0	5	
I _O	Pin current. OUT, TEST1	-5	5	mA
T _A	Ambient temperature	-40	125	°C

6.4 Thermal Information

THERMAL METRIC ⁽¹⁾		TMAG5328	UNIT
		SOT-23 (DBV)	
		6 PINS	
$R_{\theta JA}$	Junction-to-ambient thermal resistance	167.6	°C/W
$R_{\theta JC(top)}$	Junction-to-case (top) thermal resistance	84.1	°C/W
$R_{\theta JB}$	Junction-to-board thermal resistance	52.2	°C/W
Ψ_{JT}	Junction-to-top characterization parameter	32	°C/W
Ψ_{JB}	Junction-to-board characterization parameter	51.9	°C/W
$R_{\theta JC(bot)}$	Junction-to-case (bottom) thermal resistance	–	°C/W

(1) For more information about traditional and new thermal metrics, see the [Semiconductor and IC Package Thermal Metrics](#) application report.

6.5 Electrical Characteristics

over operating free-air temperature range (unless otherwise noted)

PARAMETER		TEST CONDITIONS	MIN	TYP	MAX	UNIT
ADJ pin						
ADJ_ICC	Current output source			80		μA
ADJ_C	Maximum external capacitance				50	pF
PUSH-PULL OUTPUT DRIVER						
V_{OH}	High-level output voltage	$I_{OUT} = -0.5 \text{ mA}$	$V_{CC} - 0.35$ $V_{CC} - 0.1$			V
V_{OL}	Low-level output voltage	$I_{OUT} = 0.5 \text{ mA}$		0.1	0.3	V
TMAG5328A1D						
f_s	Frequency of magnetic sampling			20		Hz
t_s	Period of magnetic sampling			50		ms
$I_{CC(AVG)}$	Average current consumption	$V_{CC} = 3.3 \text{ V}$ $T_A = 25^\circ\text{C}$		1.4	1.6	μA
		$V_{CC} = 1.65 \text{ V to } 5.5 \text{ V}$			2.3	
ALL VERSIONS						
$I_{CC(PK)}$	Peak current consumption			1.8	3	mA
$I_{CC(SLP)}$	Sleep current consumption			300	600	nA
t_{ON}	Power-on time			125		μs
P_{OS}	Power-on state without external magnetic field	$V_{CC} > V_{CCMIN}$		High		
t_{ACTIVE}	Active time period			65		μs

6.6 Magnetic Characteristics

over operating free-air temperature range (unless otherwise noted)

PARAMETER		TEST CONDITIONS	MIN	TYP	MAX	UNIT
TMAG5328A1D						
$B_{OP(Range A)}$	Adjustable Operate Point		± 2		± 15	mT
$B_{RP(Range A)}$	Adjustable Release Point		± 1		± 14	mT
$V_{ADJ (Range A)}$	Voltage range		160		1200	mV
$R_{ADJ (Range A)}$	Resistor range		2		15	kOhm
$B_{OP}(R_{ADJ})$	B_{OP}/R			± 1		mT/ kOhm
$B_{OP_ACC}(R_{ADJ})$	B_{OP} Accuracy $B_{OPSET} \pm B_{OP(MAX/MIN)}/B_{OPSET}$	$2 \text{ mT} \leq B_{OPSET} < 6 \text{ mT}$	-0.85		0.85	mT
		$6 \text{ mT} \leq B_{OPSET} \leq 15 \text{ mT}$	-1.75		1.75	
$B_{RP_ACC}(R_{ADJ})$	B_{RP} Accuracy $B_{RPSET} \pm B_{RP(MAX/MIN)}$	$2 \text{ mT} \leq B_{OPSET} < 6 \text{ mT}$	-1		1	
		$6 \text{ mT} \leq B_{OPSET} \leq 15 \text{ mT}$	-2.1		2.1	
$B_{HYSA}(R_{ADJ})$	Magnetic hysteresis	$ B_{OP} - B_{RP} $	0.25	1	1.6	

6.7 Typical Characteristics

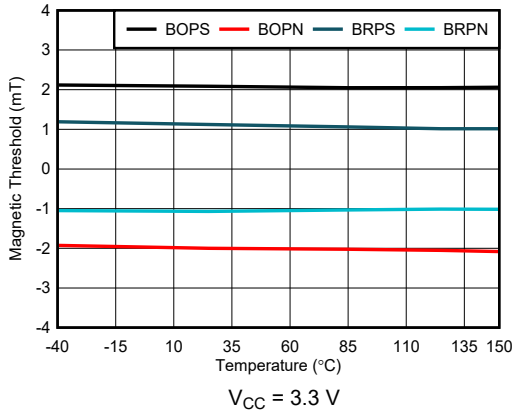

Figure 6-1. 2-mT Magnetic Threshold vs Temperature

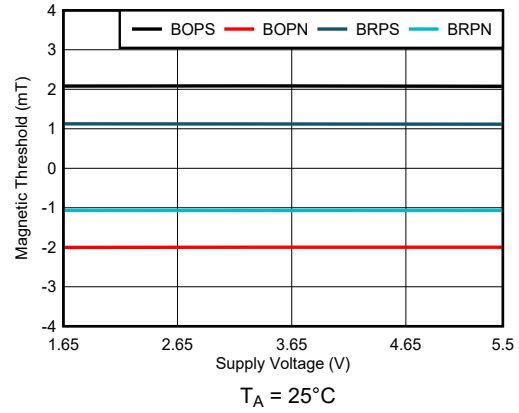

Figure 6-2. 2-mT Magnetic Threshold vs Supply

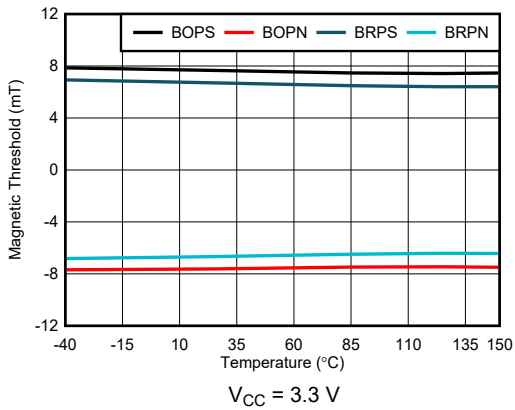

Figure 6-3. 7.5-mT Magnetic Threshold vs Temperature

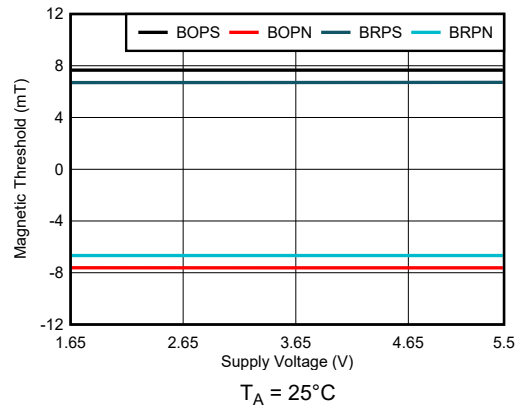

Figure 6-4. 7.5-mT Magnetic Threshold vs Supply

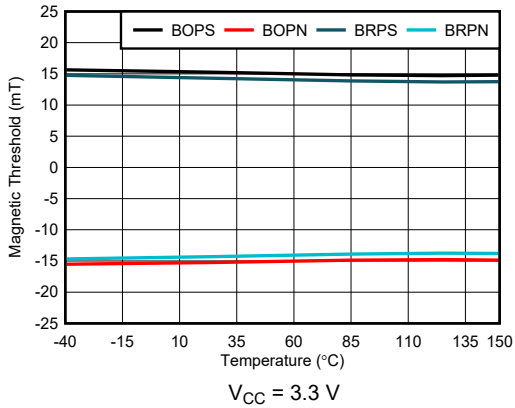

Figure 6-5. 15-mT Magnetic Threshold vs Temperature

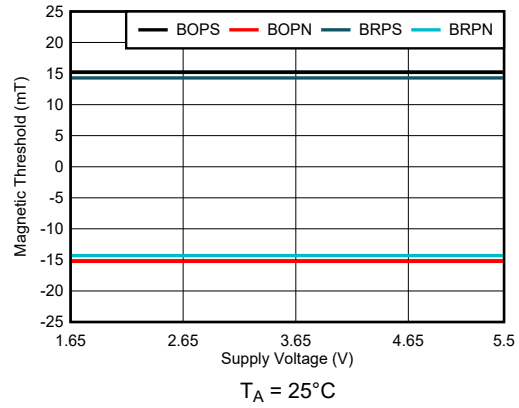

Figure 6-6. 15-mT Magnetic Threshold vs Supply

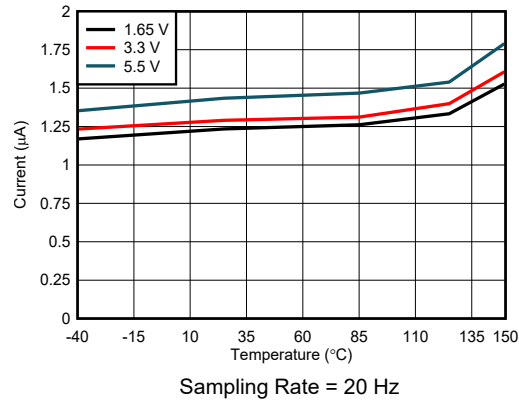

Figure 6-7. Average I_{CC} vs Temperature

7 Detailed Description

7.1 Overview

The TMAG5328 device is a magnetic sensor with a digital output that indicates when the magnetic flux density threshold has been crossed. The device integrates a Hall effect element, analog signal conditioning, and a low-frequency oscillator that enables ultra-low average power consumption.

While most of the Hall effect sensor have fixed threshold, the TMAG5328 offers an extra pin that allows the user to set up a specific threshold of operation. This pin can either be connected to a resistor or a voltage source. While the value can be set at production, it is also possible to allow dynamic change of either the resistor value or the voltage value to dynamically change the threshold value.

Operating from a 1.65-V to 5.5-V supply, the device periodically measures magnetic flux density, updates the output, and enters into a low-power sleep state.

7.2 Functional Block Diagram

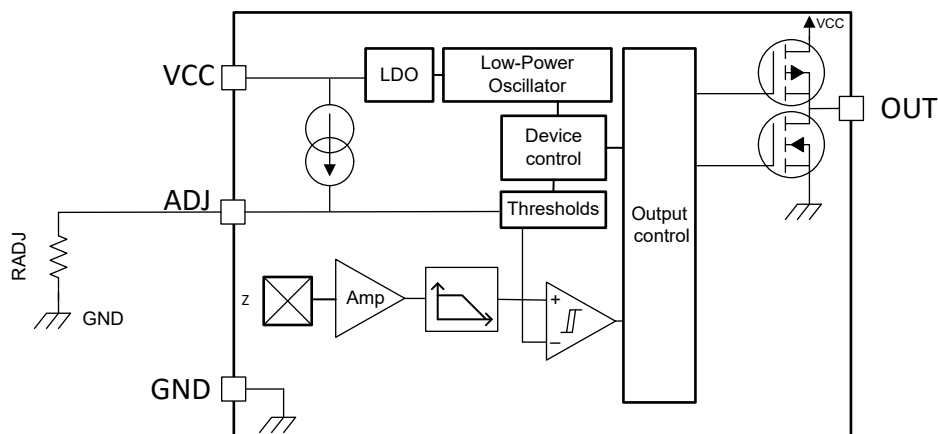

7.3 Feature Description

7.3.1 Magnetic Flux Direction

Magnetic flux that travels from the bottom to the top of the package is considered positive in this data sheet. This condition exists when a south magnetic pole is near the top of the package. Magnetic flux that travels from the top to the bottom of the package results in negative millitesla values.

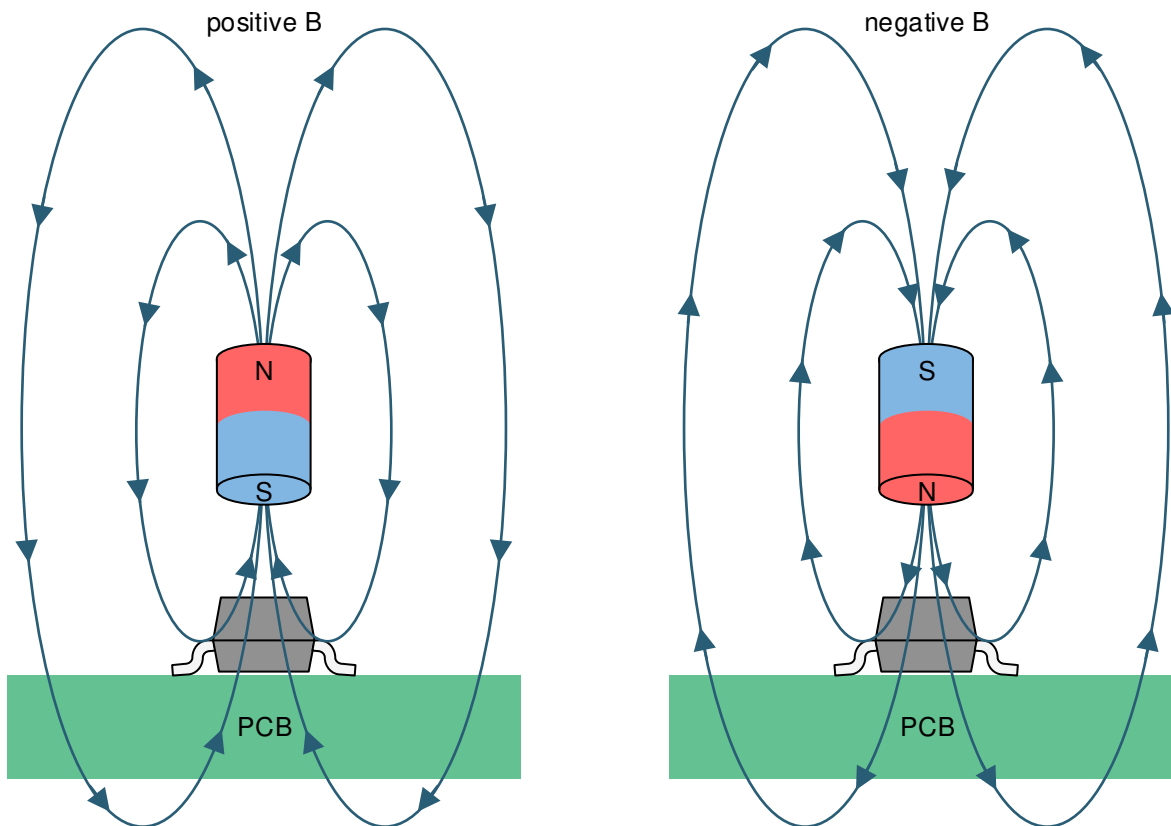

Figure 7-1. Flux Direction Polarity

7.3.2 Magnetic Response

The TMAG5328A1D has omnipolar functionality, so the device responds to both positive and negative magnetic flux densities, as shown in Figure 7-2.

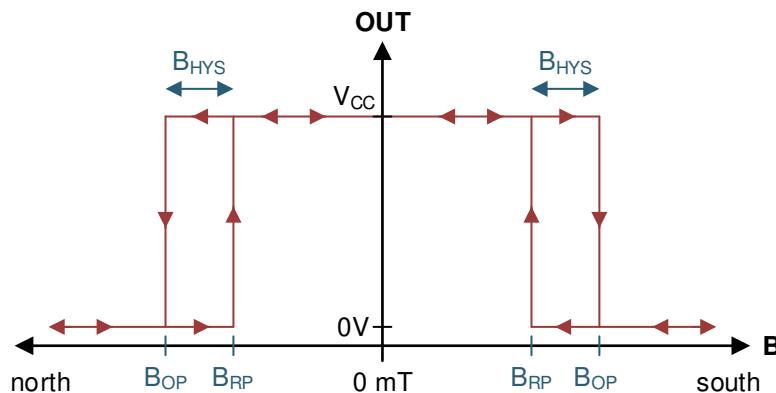

Figure 7-2. Omnipolar Functionality

7.3.3 Output Type

The TMAG5328A1D also has a push-pull CMOS output.

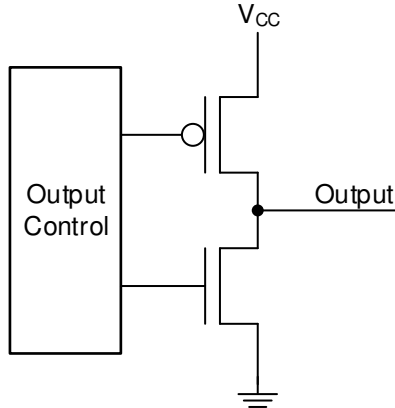

Figure 7-3. Push-Pull Output (Simplified)

7.3.4 Sampling Rate

When the TMAG5328 device powers up, the device measures the first magnetic sample and sets the output within the t_{ON} time. The output is latched, and the device enters an ultra-low-power sleep state. After each t_{Active} time has passed, the device measures a new sample and updates the output if necessary. If the magnetic field does not change between periods, the output also does not change.

While in active mode, the part will go through different steps. The content of the OTP (One-Time-Programmable Memory) is loaded first, and this step takes about 35 μs and consumes around 350 μA . For the next 5 μs , the current source will be started and settled. The part now consumes around 650 μA in this step. Finally, the part conducts the Hall sensor conversion for about 25 μs and consumes the peak current of around 2 mA.

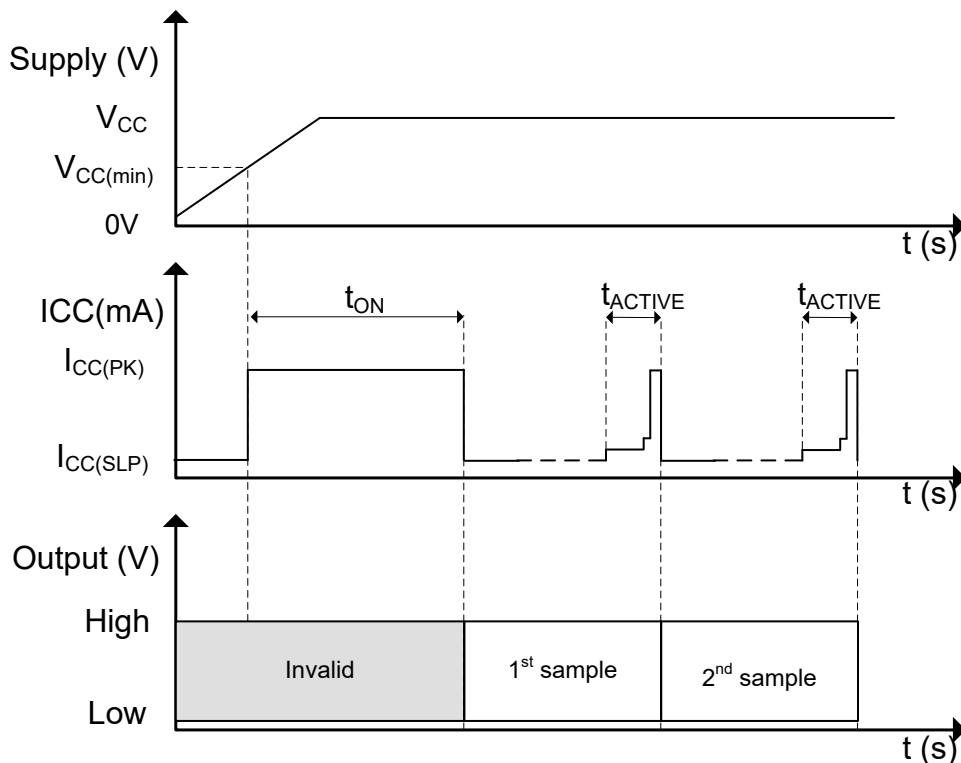

Figure 7-4. Timing Diagram

7.3.5 Adjustable Threshold

While most Hall Effect switch sensors have fixed magnetic characteristics, the TMAG5328 offers a wide range of adjustable thresholds. The user can use the "ADJ" pin to set the value of B_{OP} threshold. This pin can be used in two different ways. A resistor or a voltage source can be applied on "ADJ". In both scenarios, the resistor or voltage value will define the position of the B_{OP} . While the B_{OP} can be adjusted, the hysteresis has a fixed value. B_{RP} is therefore defined as B_{OP} -Hysteresis.

An 80- μ A current is generated on pin "ADJ" when the part goes into active mode. The device then reads the "ADJ" pin and defines the value of B_{OP} . The TMAG5328 supports adjusting the B_{OP} dynamically. If the "ADJ" pin value is adjusted while the sensor is in sleep mode, the B_{OP} will update at the next active period of the device. Consequently, the maximum time it could take for the B_{OP} to update is equal to the period of magnetic sampling, t_s .

7.3.5.1 Adjustable Resistor

One way to setup the B_{OP} is to connect a resistor to the "ADJ" pin. The device generates a fixed current that is injected in the external resistor. This will generate a voltage that represents the B_{OP} value. The relationship between B_{OP} and resistance is defined as $B_{OP}(mT) = R_{ADJ}(k\Omega)$. Please note that the generated current on the "ADJ" pin is only present when the device is in active mode and it is turned OFF when in sleep mode. As a result, the voltage on the "ADJ" pin is only present when the device is in active mode, which is a small duration compared to the time the device is in sleep mode.

The device B_{OP} must be set to any value between 2 mT and 15 mT. This means R_{ADJ} must be set between 2 k Ω and 15 k Ω . Operating above and beyond those limits is not recommended and could result in either getting the wrong threshold set or locking up the device into a specific state without the possibility of exiting.

Figure 7-5 shows the relationship between B_{OP} and R_{ADJ} .

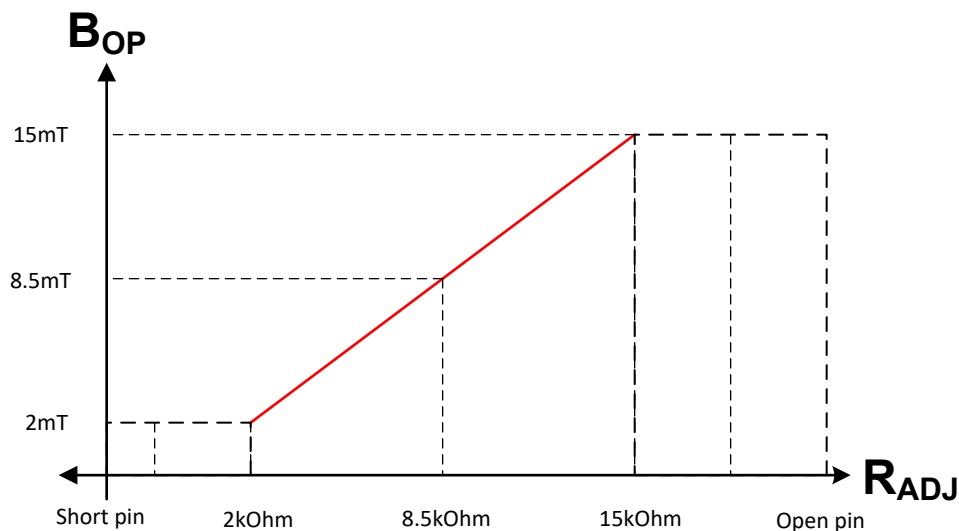

Figure 7-5. B_{OP} vs R_{ADJ}

7.3.5.2 Adjustable Voltage

One other way to setup the B_{OP} is to apply a voltage to the "ADJ" pin. This voltage is directly proportional to the B_{OP} value. The relationship between B_{OP} and voltage is defined as $B_{OP}(mT) = V_{ADJ}(mV) \times 0.0125$. To apply a voltage on the "ADJ" pin, the voltage source must be able to settle within 4 μs after being exposed to a 80 μA current on the ADJ pin.

The device B_{OP} must be set to any value between 2 mT and 15 mT. This means V_{ADJ} must be set between 160 mV and 1200 mV. Operating above and beyond those limits is not recommended and could result in either getting the wrong threshold set or locking up the device into a specific state without the possibility of exiting.

Figure 7-6 shows the relationship between B_{OP} and V_{ADJ} .

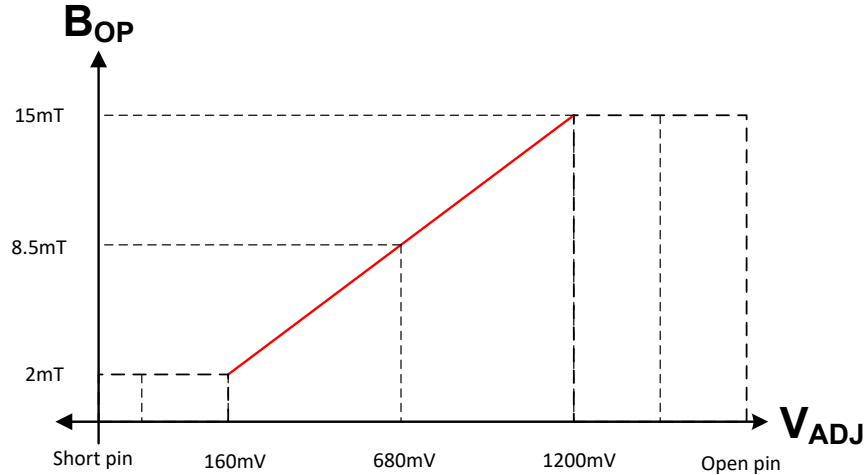

Figure 7-6. B_{OP} vs R_{ADJ}

7.3.6 Hall Element Location

Figure 7-7 shows the sensing element location inside the device.

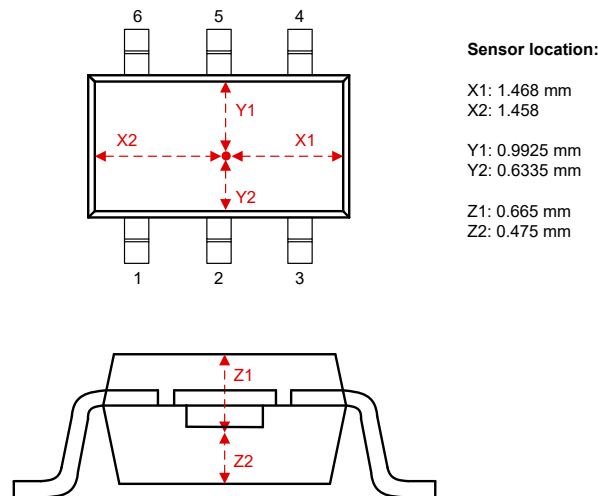

Figure 7-7. Hall Element Location

7.4 Device Functional Modes

The TMAG5328 device has one mode of operation that applies when the *Recommended Operating Conditions* are met.

8 Application and Implementation

Note

Information in the following applications sections is not part of the TI component specification, and TI does not warrant its accuracy or completeness. TI's customers are responsible for determining suitability of components for their purposes, as well as validating and testing their design implementation to confirm system functionality.

8.1 Application Information

The TMAG5328 device is typically used to detect the proximity of a magnet. The magnet is often attached to a movable component in the system.

8.1.1 Output Type Tradeoffs

The push-pull output allows for the lowest system power consumption, because there is no current leakage path when the output drives high or low. The open-drain output involves a leakage path when the output drives low, through the external pullup resistor.

The open-drain outputs of multiple devices can be tied together to form a logical AND. In this setup, if any sensor drives low, the voltage on the shared node becomes low. This can allow a single GPIO to measure an array of sensors.

8.1.2 Valid TMAG5328 Configurations

The TMAG5328 B_{OP} is set by connecting a resistor or a voltage source to the “ADJ” pin. [Figure 8-1](#) shows how to use resistor R1 to set the B_{OP} . [Figure 8-2](#) shows how to use a DAC as a voltage source for setting the B_{OP} . Using the DAC allows the user to dynamically change the B_{OP} with software. To use a DAC, the output of the DAC must settle within 4 μ s after the 80- μ A current source of the “ADJ” pin is turned ON.

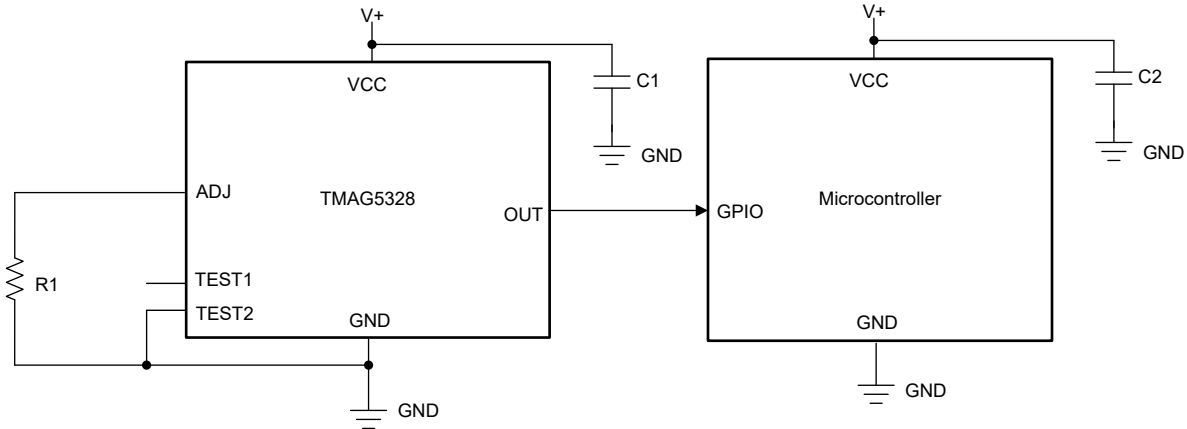

Figure 8-1. Setting B_{OP} of One TMAG5328 Device Using a Resistor

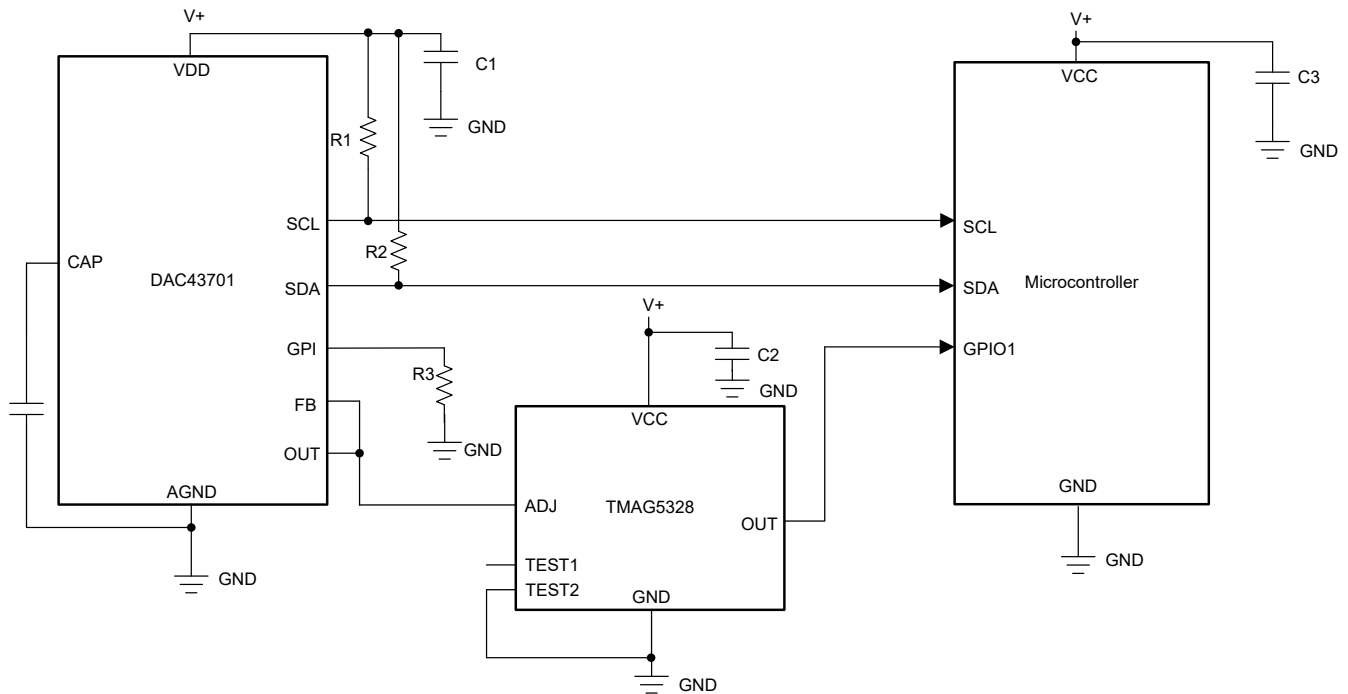

Figure 8-2. Setting B_{OP} of One TMAG5328 Device Using a DAC

As a DAC alternative, [Figure 8-3](#) shows how a voltage divider may be used as a voltage source. In [Figure 8-3](#), an operational amplifier is placed between the voltage divider and the “ADJ” pin so that the voltage fed to the “ADJ” pin is not impacted by the internal current source of the TMAG5328 when the current source is turned ON. To use an op amp, the output of the op amp must settle within 4 μ s after the 80- μ A current source of the “ADJ” pin is turned ON.

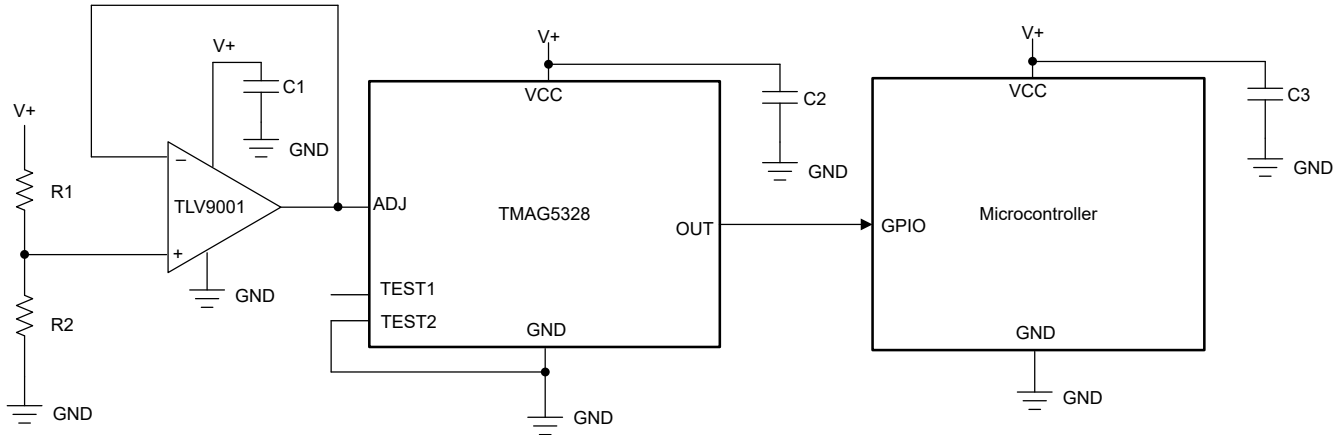

Figure 8-3. Setting B_{OP} of One TMAG5328 Device Using a Voltage Divider

A potentiometer or rheostat may be integrated into a voltage divider, and the user can adjust this potentiometer to dynamically update the B_{OP} . [Figure 8-4](#) shows how to use a potentiometer in a voltage divider to set the B_{OP} of the TMAG5328. The maximum output voltage, which determines the maximum B_{OP} , is set based on the values of resistors R1 and R3. The minimum output voltage, which determines the minimum B_{OP} , is set based on the values of the maximum potentiometer resistance, R1’s resistance, and R3’s resistance. The user should select a minimum output voltage greater than 0.16 V and a maximum output voltage less than 1.2 V.

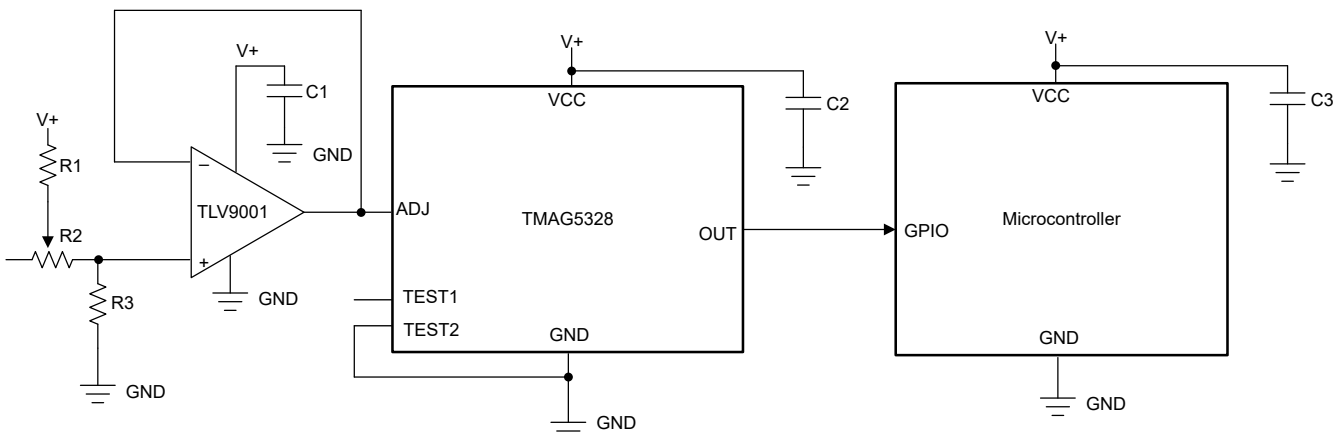

Figure 8-4. Setting B_{OP} of One TMAG5328 Device Using a Voltage Divider and Potentiometer

Figure 8-5 shows how the TMAG5328's internal current source can drive a potentiometer or rheostat instead of a voltage divider. In this implementation, resistor R2 should be at least 2 kΩ to ensure that the “ADJ” resistance is always above its minimum 2 kΩ. The sum of the maximum potentiometer resistance and the resistance of R1 must also be less than 15 kΩ.

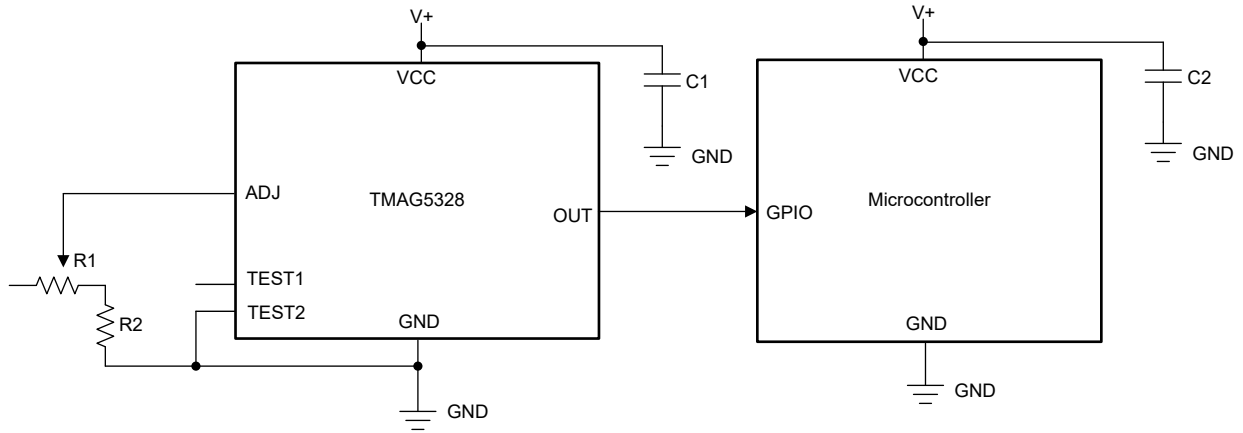

Figure 8-5. Setting B_{OP} of One TMAG5328 Device Using a Potentiometer and the TMAG5328's Internal Current Source

Multiple TMAG5328 devices may be used in the same system. When setting the B_{OP} using a resistor, TI recommends that each TMAG5328 has its own “ADJ” resistor, even if multiple TMAG5328 devices have the same “ADJ” resistor value. Figure 8-6 shows an example implementation that has three TMAG5328 devices. If each device is set to the same B_{OP} , then the resistances of R1, R2, and R3 are equal.

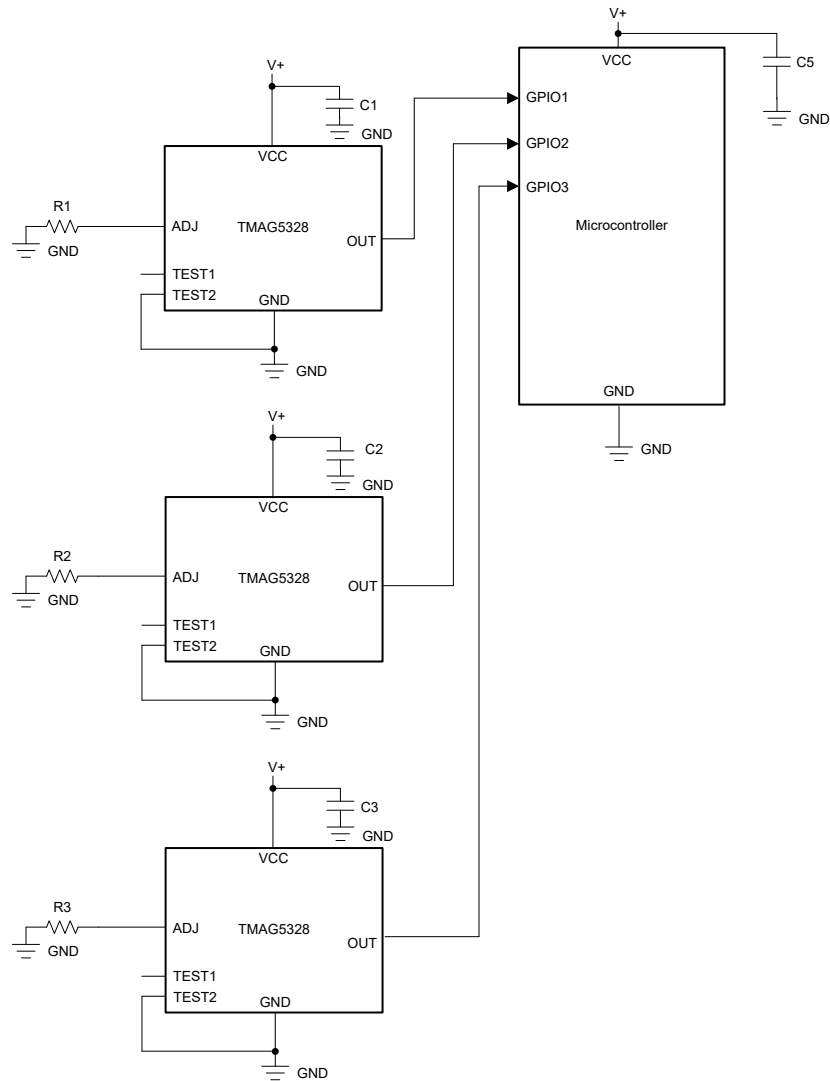

Figure 8-6. Setting B_{OP} of Three TMAG5328 Devices Using Three Resistors

When setting the B_{OP} using a DAC, one DAC can be used to set the “ADJ” pin voltage of multiple devices only if the DAC’s output could sink the current from all of the TMAG5328 devices. Figure 8-7 shows an example of a DAC driving the “ADJ” pin of three TMAG5328 devices. A DAC can only work reliably in this specific scenario if the DAC’s output can settle within 4 μ s after being exposed to the three “ADJ” current sources. Each current source is 80 μ A, therefore the DAC can only reliably work if the DAC’s output can settle within 4 μ s after being exposed to $80 \times 3 = 240 \mu$ A of current.

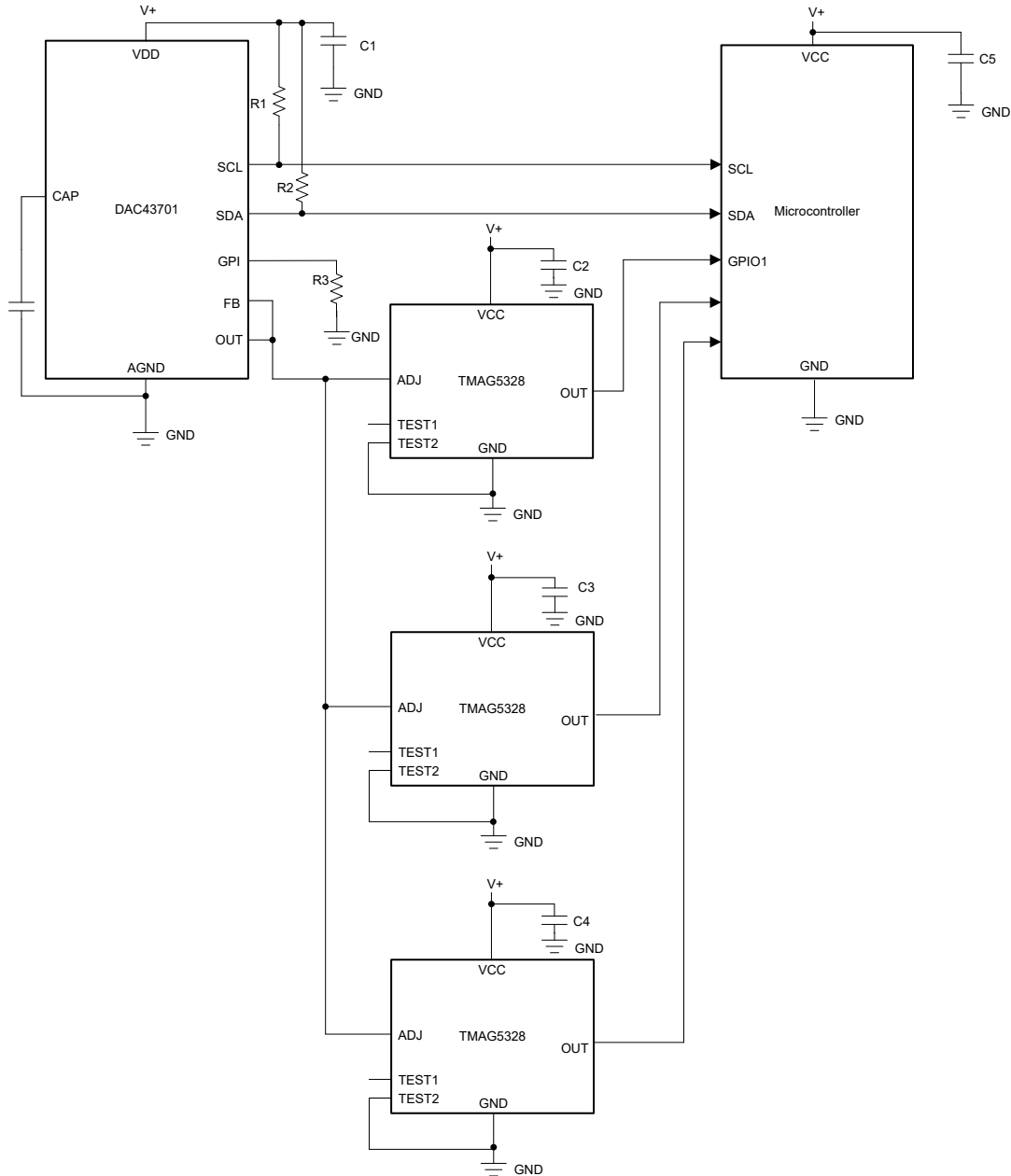

Figure 8-7. Setting B_{OP} of Three TMAG5328 Devices Using a DAC

8.2 Typical Applications

The TMAG5328 can be used in a large variety of industrial applications. For almost all these applications, the sensor is fixed and the magnet is attached to a movable component in the system.

8.2.1 Refrigerator Door Open/Close Detection

This application section describes how to use the same device for two identical applications with different mechanical characteristic.

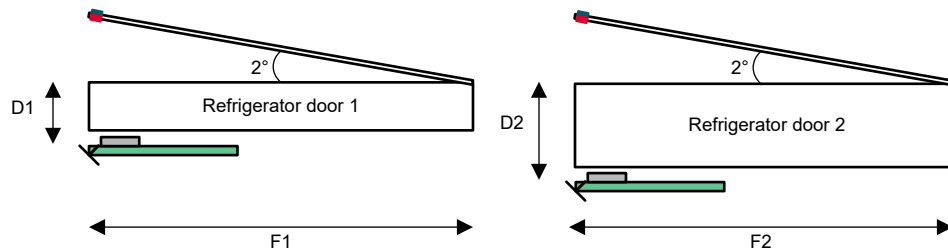

Figure 8-8. Refrigerator 1 and Refrigerator 2 Principal Diagram

8.2.1.1 Design Requirements

For this design example, use the parameters listed in [Table 8-1](#).

Table 8-1. Design Parameters for Fridge 1

DESIGN PARAMETER	EXAMPLE VALUE
Hall effect device	TMAG5328A1D
V_{CC}	5 V
Magnet	10 mm cubic N35
D1	7.025 mm
F1	500 mm
Door opening angle	2°
Calculated threshold needed (B_{OP})	7.87 mT
R_{ADJ}	7.87 k Ω

Table 8-2. Design Parameters for Fridge 2

DESIGN PARAMETER	EXAMPLE VALUE
Hall effect device	TMAG5328A1D
V_{CC}	5 V
Magnet	10 mm cubic N35
D2	16.08 mm
F2	500 mm
Door opening angle	2°
Calculated threshold needed (B_{OP})	3.49 mT
R_{ADJ}	3.48 k Ω

8.2.1.2 Detailed Design Procedure

For both applications, the Hall sensor is used to detect if the refrigerator door is open or closed. Both refrigerator doors are different from each other and therefore have different mechanical design. This means the Hall sensor and the magnet are positioned differently from each other. In other terms, if the user wants to detect a specific distance for both refrigerator doors, they must use either a different magnet or a different sensor. For the purpose of this application, there is no flexibility in the choice of magnet. The electronic board will also be reused across platforms and therefore will use the same sensor.

The TMAG5328 is a resistor adjustable Hall effect switch that allows the user to set up whatever threshold is needed between 2 mT and 15 mT.

For this application, the refrigerator door manufacturer can use the same printed circuit board (PCB) with the same semiconductor content and only has to change the resistor value depending on which refrigerator version is manufactured.

For both refrigerator doors, the opening angle is the same. Now refrigerator door 1 is a thinner model than refrigerator door 2. This means the PCB is located further away for refrigerator door 2 and therefore the sensitivity required to detect the position of the door will be impacted.

Knowing the door dimensions, the door opening angle required, and the distance from the magnet to the PCB, it is possible to use a simulation tool that will calculate the magnet strength at the desired position. For refrigerator door 1, the sensitivity calculated is 7.87 mT at a distance of 7.025 mm. For Refrigerator 2, the sensitivity is 3.49 mT at a distance of 16.08 mm. Based on those values, a resistor value can be selected from the E48 series. A resistor of 7.87 kΩ can be used for refrigerator door 1 and resistor of 3.48 kΩ can be used for refrigerator door 2.

9 Power Supply Recommendations

The TMAG5328 device is powered from 1.65-V to 5.5-V DC power supplies. A decoupling capacitor close to the device must be used to provide local energy with minimal inductance. TI recommends using a ceramic capacitor with a value of at least 0.1 μF.

10 Layout

10.1 Layout Guidelines

Magnetic fields pass through most non-ferromagnetic materials with no significant disturbance. Embedding Hall effect sensors within plastic or aluminum enclosures and sensing magnets on the outside is common practice. Magnetic fields also easily pass through most printed circuit boards, which makes placing the magnet on the opposite side possible.

10.2 Layout Examples

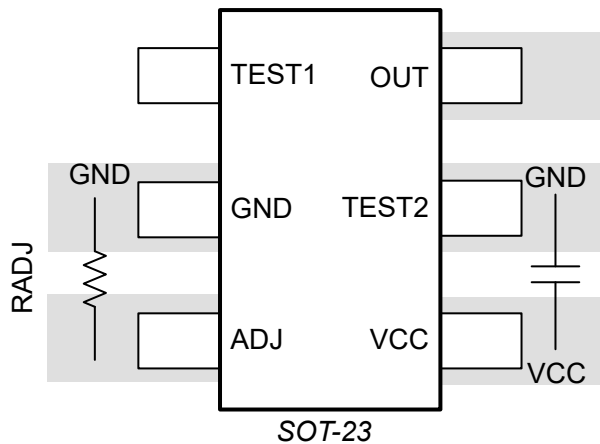

Figure 10-1. Layout Examples

11 Device and Documentation Support

11.1 Receiving Notification of Documentation Updates

To receive notification of documentation updates, navigate to the device product folder on ti.com. Click on *Subscribe to updates* to register and receive a weekly digest of any product information that has changed. For change details, review the revision history included in any revised document.

11.2 Support Resources

TI E2E™ [support forums](#) are an engineer's go-to source for fast, verified answers and design help — straight from the experts. Search existing answers or ask your own question to get the quick design help you need.

Linked content is provided "AS IS" by the respective contributors. They do not constitute TI specifications and do not necessarily reflect TI's views; see TI's [Terms of Use](#).

11.3 Trademarks

TI E2E™ is a trademark of Texas Instruments.

All trademarks are the property of their respective owners.

11.4 Electrostatic Discharge Caution



This integrated circuit can be damaged by ESD. Texas Instruments recommends that all integrated circuits be handled with appropriate precautions. Failure to observe proper handling and installation procedures can cause damage.

ESD damage can range from subtle performance degradation to complete device failure. Precision integrated circuits may be more susceptible to damage because very small parametric changes could cause the device not to meet its published specifications.

11.5 Glossary

[TI Glossary](#) This glossary lists and explains terms, acronyms, and definitions.

12 Mechanical, Packaging, and Orderable Information

The following pages include mechanical, packaging, and orderable information. This information is the most current data available for the designated devices. This data is subject to change without notice and revision of this document. For browser-based versions of this data sheet, refer to the left-hand navigation.

PACKAGING INFORMATION

Orderable Device	Status (1)	Package Type	Package Drawing	Pins	Package Qty	Eco Plan (2)	Lead finish/ Ball material (6)	MSL Peak Temp (3)	Op Temp (°C)	Device Marking (4/5)	Samples
TMAG5328A1DQDBVR	ACTIVE	SOT-23	DBV	6	3000	RoHS & Green	SN	Level-1-260C-UNLIM	-40 to 125	A1D	Samples

(1) The marketing status values are defined as follows:

ACTIVE: Product device recommended for new designs.

LIFEBUY: TI has announced that the device will be discontinued, and a lifetime-buy period is in effect.

NRND: Not recommended for new designs. Device is in production to support existing customers, but TI does not recommend using this part in a new design.

PREVIEW: Device has been announced but is not in production. Samples may or may not be available.

OBSELETE: TI has discontinued the production of the device.

(2) **RoHS:** TI defines "RoHS" to mean semiconductor products that are compliant with the current EU RoHS requirements for all 10 RoHS substances, including the requirement that RoHS substance do not exceed 0.1% by weight in homogeneous materials. Where designed to be soldered at high temperatures, "RoHS" products are suitable for use in specified lead-free processes. TI may reference these types of products as "Pb-Free".

RoHS Exempt: TI defines "RoHS Exempt" to mean products that contain lead but are compliant with EU RoHS pursuant to a specific EU RoHS exemption.

Green: TI defines "Green" to mean the content of Chlorine (Cl) and Bromine (Br) based flame retardants meet JS709B low halogen requirements of <=1000ppm threshold. Antimony trioxide based flame retardants must also meet the <=1000ppm threshold requirement.

(3) MSL, Peak Temp. - The Moisture Sensitivity Level rating according to the JEDEC industry standard classifications, and peak solder temperature.

(4) There may be additional marking, which relates to the logo, the lot trace code information, or the environmental category on the device.

(5) Multiple Device Markings will be inside parentheses. Only one Device Marking contained in parentheses and separated by a "-" will appear on a device. If a line is indented then it is a continuation of the previous line and the two combined represent the entire Device Marking for that device.

(6) Lead finish/Ball material - Orderable Devices may have multiple material finish options. Finish options are separated by a vertical ruled line. Lead finish/Ball material values may wrap to two lines if the finish value exceeds the maximum column width.

Important Information and Disclaimer:The information provided on this page represents TI's knowledge and belief as of the date that it is provided. TI bases its knowledge and belief on information provided by third parties, and makes no representation or warranty as to the accuracy of such information. Efforts are underway to better integrate information from third parties. TI has taken and continues to take reasonable steps to provide representative and accurate information but may not have conducted destructive testing or chemical analysis on incoming materials and chemicals. TI and TI suppliers consider certain information to be proprietary, and thus CAS numbers and other limited information may not be available for release.

In no event shall TI's liability arising out of such information exceed the total purchase price of the TI part(s) at issue in this document sold by TI to Customer on an annual basis.

TAPE AND REEL INFORMATION

QUADRANT ASSIGNMENTS FOR PIN 1 ORIENTATION IN TAPE

*All dimensions are nominal

Device	Package Type	Package Drawing	Pins	SPQ	Reel Diameter (mm)	Reel Width W1 (mm)	A0 (mm)	B0 (mm)	K0 (mm)	P1 (mm)	W (mm)	Pin1 Quadrant
TMAG5328A1DQDBVR	SOT-23	DBV	6	3000	178.0	9.0	3.3	3.2	1.4	4.0	8.0	Q3

TAPE AND REEL BOX DIMENSIONS

*All dimensions are nominal

Device	Package Type	Package Drawing	Pins	SPQ	Length (mm)	Width (mm)	Height (mm)
TMAG5328A1DQDBVR	SOT-23	DBV	6	3000	190.0	190.0	30.0



DBV0006A

PACKAGE OUTLINE

SOT-23 - 1.45 mm max height

SMALL OUTLINE TRANSISTOR

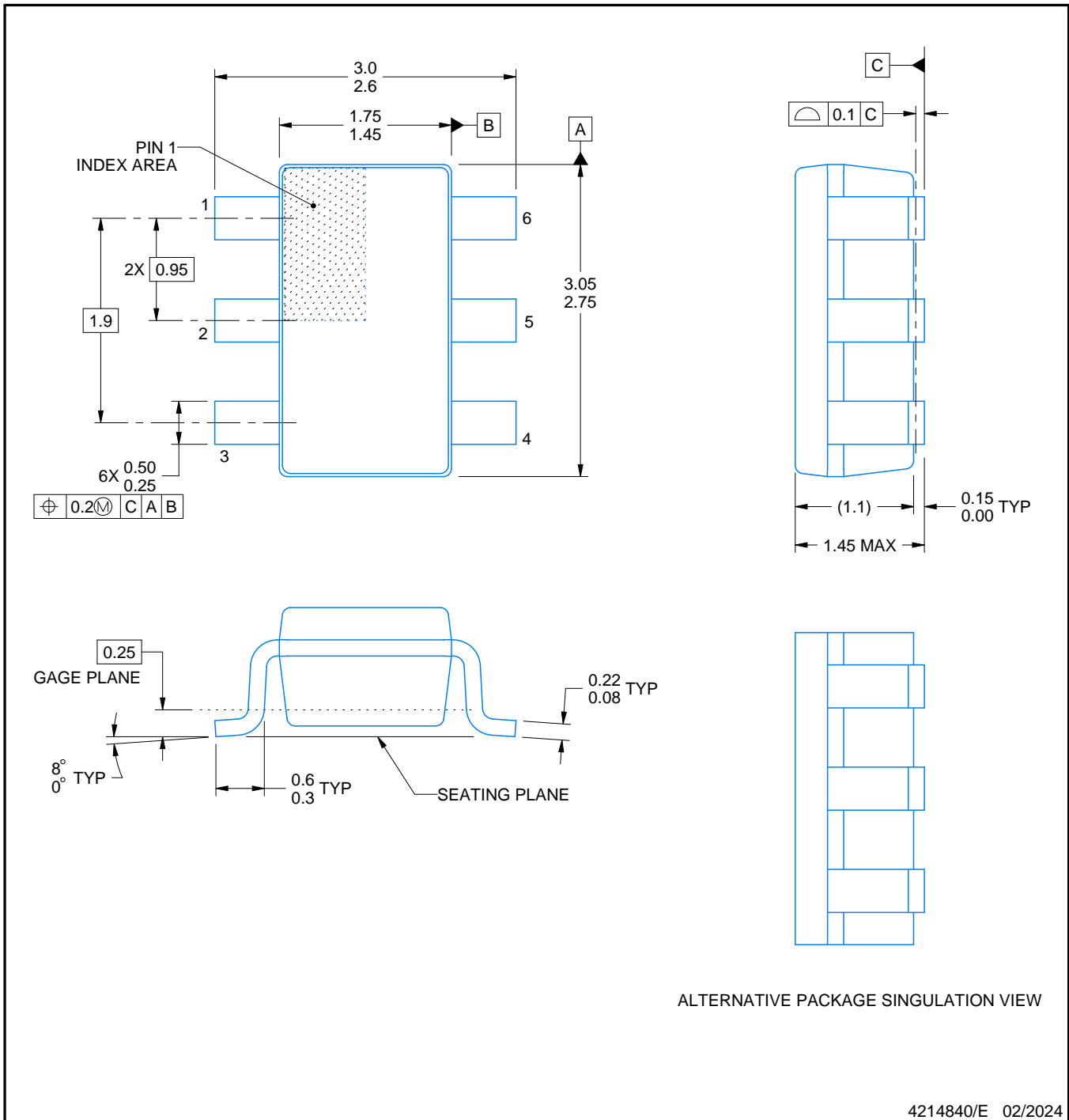

ALTERNATIVE PACKAGE SINGULATION VIEW

4214840/E 02/2024

NOTES:

1. All linear dimensions are in millimeters. Any dimensions in parenthesis are for reference only. Dimensioning and tolerancing per ASME Y14.5M.
2. This drawing is subject to change without notice.
3. Body dimensions do not include mold flash or protrusion. Mold flash and protrusion shall not exceed 0.25 per side.
4. Leads 1,2,3 may be wider than leads 4,5,6 for package orientation.
5. Reference JEDEC MO-178.

EXAMPLE BOARD LAYOUT

DBV0006A

SOT-23 - 1.45 mm max height

SMALL OUTLINE TRANSISTOR



LAND PATTERN EXAMPLE
EXPOSED METAL SHOWN
SCALE:15X

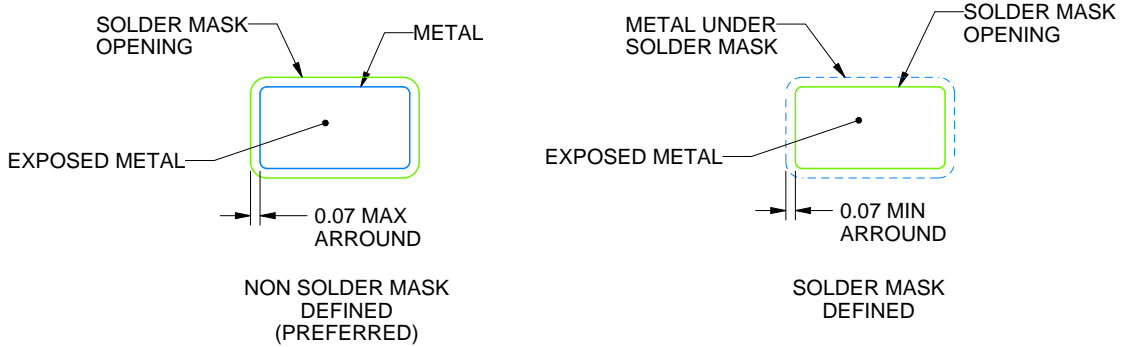

SOLDER MASK DETAILS

4214840/E 02/2024

NOTES: (continued)

- 6. Publication IPC-7351 may have alternate designs.
- 7. Solder mask tolerances between and around signal pads can vary based on board fabrication site.

EXAMPLE STENCIL DESIGN

DBV0006A

SOT-23 - 1.45 mm max height

SMALL OUTLINE TRANSISTOR



SOLDER PASTE EXAMPLE
BASED ON 0.125 mm THICK STENCIL
SCALE:15X

4214840/E 02/2024

NOTES: (continued)

8. Laser cutting apertures with trapezoidal walls and rounded corners may offer better paste release. IPC-7525 may have alternate design recommendations.
9. Board assembly site may have different recommendations for stencil design.

IMPORTANT NOTICE AND DISCLAIMER

TI PROVIDES TECHNICAL AND RELIABILITY DATA (INCLUDING DATA SHEETS), DESIGN RESOURCES (INCLUDING REFERENCE DESIGNS), APPLICATION OR OTHER DESIGN ADVICE, WEB TOOLS, SAFETY INFORMATION, AND OTHER RESOURCES "AS IS" AND WITH ALL FAULTS, AND DISCLAIMS ALL WARRANTIES, EXPRESS AND IMPLIED, INCLUDING WITHOUT LIMITATION ANY IMPLIED WARRANTIES OF MERCHANTABILITY, FITNESS FOR A PARTICULAR PURPOSE OR NON-INFRINGEMENT OF THIRD PARTY INTELLECTUAL PROPERTY RIGHTS.

These resources are intended for skilled developers designing with TI products. You are solely responsible for (1) selecting the appropriate TI products for your application, (2) designing, validating and testing your application, and (3) ensuring your application meets applicable standards, and any other safety, security, regulatory or other requirements.

These resources are subject to change without notice. TI grants you permission to use these resources only for development of an application that uses the TI products described in the resource. Other reproduction and display of these resources is prohibited. No license is granted to any other TI intellectual property right or to any third party intellectual property right. TI disclaims responsibility for, and you will fully indemnify TI and its representatives against, any claims, damages, costs, losses, and liabilities arising out of your use of these resources.

TI's products are provided subject to [TI's Terms of Sale](#) or other applicable terms available either on [ti.com](https://www.ti.com) or provided in conjunction with such TI products. TI's provision of these resources does not expand or otherwise alter TI's applicable warranties or warranty disclaimers for TI products.

TI objects to and rejects any additional or different terms you may have proposed.

Mailing Address: Texas Instruments, Post Office Box 655303, Dallas, Texas 75265
Copyright © 2024, Texas Instruments Incorporated