

TMAG6181-Q1 High-Precision Analog AMR Angle Sensor With Integrated Turns Counter

1 Features

- AEC-Q100 qualified for automotive applications:
 - Temperature grade 0: -40°C to 150°C
- [Functional Safety-Compliant](#)
 - Developed for functional safety applications
 - Documentation to aid ISO 26262 system design up to ASIL B
- High-accuracy, low angle error AMR sensor:
 - 0.1° (typical)
 - 0.4° (maximum across temperature at 3.3V)
 - 0.56° (maximum across temperature at 5.5V)
- High-speed AMR angle sensor:
 - Ultra low latency $< 2\mu\text{s}$ supports up to 100krpm
 - Angle range: 180°
- Low angle drift eliminates the need for calibration across temperatures
- Wide operating magnetic field range: 20mT to 1T
- Sine and cosine differential ratiometric analog outputs
- Supports differential-ended or single-ended applications
- Fast start-up time: $< 40\mu\text{s}$
- Integrated Turns Counter provides rotation turns count using PWM output:
 - Low-power mode with turns counter enabled of $50\mu\text{A}$
 - Intelligent rotation tracking enables to track up to 8krpm in low-power mode
- Dedicated pin to enter sleep mode: $< 5\mu\text{A}$
- Supply voltage range: 2.7V to 5.5V

2 Applications

- [EPS Motor Position Sensing](#)
- [EPS Handwheel Angle Sensing](#)
- [BLDC/PMSM Motor Position Sensing](#)
- [E-bikes and 2-wheelers](#)
- [Wiper Modules and Actuators](#)
- [Encoder Position Sensing](#)
- [Servo Drive Position Sensors](#)
- [Integrated Belt Starter Generators](#)

3 Description

The TMAG6181-Q1 is a high-precision angle sensor based on Anisotropic Magneto Resistive (AMR) technology. The device features integrated signal conditioning amplifiers and provides differential sine and cosine analog outputs related to the direction of the applied in-plane magnetic field. This device also features two independent Hall sensors at X and Y axes that are used to keep track of rotations.

The TMAG6181-Q1 features a wide operating magnetic field (20mT – 1T) that enables flexible mechanical placements as well as low latency ($< 2\mu\text{s}$) outputs for high-speed applications like rotor position sensing. The fast start-up time ($< 40\mu\text{s}$) enables low power applications by using a sleep pin that enables the device to enter two low power modes: sleep mode and a low power turns counting mode. An integrated turns counter keeps track of the number of rotations, and the turns counter value is transmitted using PWM on the TURNS pin.

The TMAG6181-Q1 offers extensive diagnostics and is designed for Functional Safety applications. The device performs consistently across a wide ambient temperature range of -40°C to 150°C with minimal thermal drift and lifetime errors.

Package Information

PART NUMBER	PACKAGE ⁽¹⁾	PACKAGE SIZE ⁽²⁾
TMAG6181-Q1	DGK (VSSOP, 8)	3.00mm × 4.90mm

- (1) For all available packages, see [Section 10](#).
- (2) The package size (length × width) is a nominal value and includes pins, where applicable.

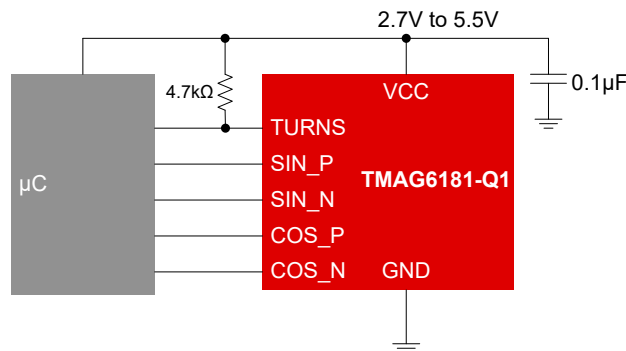

Application Block Diagram



Table of Contents

1 Features	1	6.4 Device Functional Modes.....	27
2 Applications	1	7 Application and Implementation	29
3 Description	1	7.1 Application Information.....	29
4 Pin Configuration and Functions	3	7.2 Typical Application.....	31
5 Specifications	4	7.3 Power Supply Recommendations.....	36
5.1 Absolute Maximum Ratings.....	4	7.4 Layout.....	36
5.2 ESD Ratings.....	4	8 Device and Documentation Support	37
5.3 Recommended Operating Conditions.....	4	8.1 Receiving Notification of Documentation Updates...37	
5.4 Thermal Information.....	4	8.2 Support Resources.....	37
5.5 Electrical Characteristics.....	5	8.3 Trademarks.....	37
5.6 Magnetic Characteristics.....	7	8.4 Electrostatic Discharge Caution.....	37
5.7 Typical Characteristics.....	8	8.5 Glossary.....	37
6 Detailed Description	10	9 Revision History	37
6.1 Overview.....	10	10 Mechanical, Packaging, and Orderable Information	37
6.2 Functional Block Diagram.....	10		
6.3 Feature Description.....	11		

4 Pin Configuration and Functions

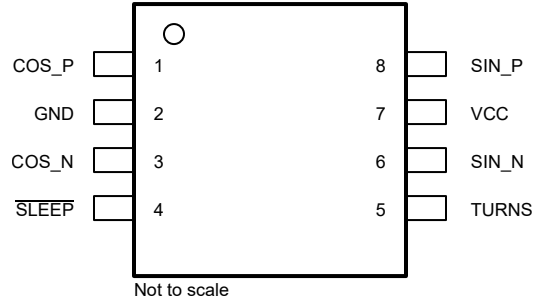

Figure 4-1. DGK Package 8-Pin VSSOP Top View

Table 4-1. Pin Functions

PIN		TYPE ⁽¹⁾	DESCRIPTION
NO.	NAME		
1	COS_P	O	Differential cosine output (positive)
2	GND	G	Ground reference
3	COS_N	O	Differential cosine output (negative)
4	$\overline{\text{SLEEP}}$	I	$\overline{\text{SLEEP}}$ pin (active low)
5	TURNS	I/O	Turns counter output or Reset input (open drain)
6	SIN_N	O	Differential sine output (negative)
7	VCC	P	Power supply
8	SIN_P	O	Differential sine output (positive)

(1) I = input, O = output, I/O = input and output, G = ground, P = power

5 Specifications

5.1 Absolute Maximum Ratings

over operating free-air temperature range (unless otherwise noted)⁽¹⁾

		MIN	MAX	UNIT
V _{CC}	Main supply voltage	-0.3	7	V
I _{OUT}	Output current (SIN_P, SIN_N, COS_P, COS_N, TURNS)	-10	10	mA
V _{OUT}	Output voltage (SIN_P, SIN_N, COS_P, COS_N, TURNS)	-0.3	7	V
V _{IN}	Input voltage $\overline{\text{SLEEP}}$	-0.3	V _{VCC} + 0.3	V
T _J	Junction temperature	-40	170	°C
T _{stg}	Storage temperature	-65	150	°C

- (1) Operation outside the Absolute Maximum Ratings may cause permanent device damage. Absolute maximum ratings do not imply functional operation of the device at these or any other conditions beyond those listed under Recommended Operating Conditions. If briefly operating outside the Recommended Operating Conditions but within the Absolute Maximum Ratings, the device may not sustain damage, but it may not be fully functional. Operating the device in this manner may affect device reliability, functionality, performance, and shorten the device lifetime.

5.2 ESD Ratings

			VALUE	UNIT
V _(ESD)	Electrostatic discharge	Human body model (HBM), per AEC Q100-002 ⁽¹⁾ HBM ESD classification level 2	±2000	V
		Charged device model (CDM), per AEC Q100-011	±500	
		CDM ESD classification level C4B	±750	

- (1) AEC Q100-002 indicates that HBM stressing shall be in accordance with the ANSI/ESDA/JEDEC JS-001 specification.

5.3 Recommended Operating Conditions

over operating free-air temperature range (unless otherwise noted)

		MIN	NOM	MAX	UNIT
V _{CC}	Main supply voltage	2.7		5.5	V
T _A	Operating free air temperature	-40		150	C
C _L	Capacitive load on SIN_P, SIN_N, COS_P, COS_N	0.1		10	nF
I _L	Current load on SIN_P, SIN_N, COS_P, COS_N	-1		1	mA
B	Magnetic flux density for AMR saturation	20			mT

5.4 Thermal Information

THERMAL METRIC ⁽¹⁾		TMAG6181-Q1	UNIT
		DGK (VSSOP)	
		8 PINS	
R _{θJA}	Junction-to-ambient thermal resistance	166.8	°C/W
R _{θJC(top)}	Junction-to-case (top) thermal resistance	57.8	°C/W
R _{θJB}	Junction-to-board thermal resistance	88.7	°C/W
Ψ _{JT}	Junction-to-top characterization parameter	7.0	°C/W
Ψ _{JB}	Junction-to-board characterization parameter	87.1	°C/W

- (1) For more information about traditional and new thermal metrics, see the [Semiconductor and IC Package Thermal Metrics](#) application report.

5.5 Electrical Characteristics

over operating free-air temperature range (unless otherwise noted); typical specifications are at $T_A = 25^\circ\text{C}$

PARAMETER		TEST CONDITIONS	MIN	TYP	MAX	UNIT
AMR Output Parameters						
V_{out}	Single-ended output voltage peak to peak	$V_{CC} = 3.3\text{V}$	57	62	67.5	% V_{CC}
		$V_{CC} = 5.5\text{V}$	55	60	65	
k	Amplitude asynchronism ratio (Vpk Cos/ Vpk Vsin)	B = 30mT, $V_{CC} = 3.3\text{V}$	-2.3	0.3	2.3	%
		B = 30mT, $V_{CC} = 5\text{V}$	-2.4	0.3	2.4	
$V_{offset_room}^{(1)}$	Differential offset of SIN/COS outputs at room	B = 30mT, $T_A = 25^\circ\text{C}$, $V_{CC} = 3.3\text{V}$	-56		56	mV
		B = 30mT, $T_A = 25^\circ\text{C}$, $V_{CC} = 5\text{V}$	-90		90	
V_{offset_tc}	Temperature coefficient of differential offset voltage	B = 30mT, $V_{CC} = 3.3\text{V}$		± 0.1		mV/ $^\circ\text{C}$
		B = 30mT, $V_{CC} = 5\text{V}$		± 0.1		
V_{CM}	Common-mode output voltage	B = 30mT, $V_{CC} = 3.3\text{V}$	48	50	52	% V_{CC}
		B = 30mT, $V_{CC} = 5\text{V}$	48	50	52	
V_{NOISE}	Output referred noise (differential)	B = 30mT, $C_{load} = 100\text{pF}$		0.5		mV $_{rms}$
R_{out}	Series output resistance			55		Ω
R_{out_sleep}	Series output resistance during Sleep	$\overline{\text{SLEEP}} = \text{GND}$	1			M Ω
$t_{agc_update}^{(2)}$	Update rate of the automatic gain control	After V_{out} reaching 60% of V_{CC}		1		s
DC Power						
V_{CC_UV}	VCC undervoltage threshold			2.45	2.65	V
V_{CC_OV}	VCC overvoltage threshold			5.9	6.36	
I_{ACT}	Active mode current from VCC	$\overline{\text{SLEEP}} = \text{VCC}$		5	10	mA
I_{DCM_SLEEP}	Sleep mode current from VCC	DCM mode enabled		50		μA
I_{SLEEP}	Sleep mode current from VCC	$\overline{\text{SLEEP}} = \text{GND}$		4.5		μA
I_{LP}	Average current during low power mode from VCC	Low power DCM mode with turns counter enabled (no rotations detected)		50		μA
$t_{sleep_no_rotation}$	Sleep time during low power mode when the magnetic field is static (not rotating)	B = 30 mT		25		ms
$t_{on_startup}$	Power-on time during start-up	To achieve 90% of output voltages after VCC has reached final value ($C_{LOAD} = 100\text{pF}$)		38	85	μs
t_{on_sleep}	Power on time after $\overline{\text{SLEEP}}$ goes high	To achieve 90% of output voltages after $\overline{\text{SLEEP}} > V_{IH}$ ($C_{LOAD} = 100\text{pF}$)		45	50	μs
t_{sleep_pd}	Time that $\overline{\text{SLEEP}}$ must stay low when transitioning from active mode to low power mode		125		400	μs
$t_{sleep_timeout}$	Timeout between two consecutive pulses on $\overline{\text{SLEEP}}$ pin when entering low power mode		25		400	μs
t_{sleep_mode}	Time that $\overline{\text{SLEEP}}$ must stay low to enter sleep mode		1.1			ms
Digital I/O						
V_{IH}	High level input voltage	$\overline{\text{SLEEP}}$	$0.65 \times V_{CC}$			V
V_{IL}	Low level input voltage				$0.3 \times V_{CC}$	

over operating free-air temperature range (unless otherwise noted); typical specifications are at $T_A = 25^\circ\text{C}$

PARAMETER		TEST CONDITIONS	MIN	TYP	MAX	UNIT
V_{IH}	High level input voltage	TURNS	$0.65 \times V_{CC}$			V
V_{IL}	Low level input voltage				$0.3 \times V_{CC}$	V
V_{OL}	Low level output voltage	$I_O = 2\text{mA}$ on TURNS pin	0		0.4	V
Turns Counter						
f_{PWM}	PWM carrier frequency	When Turns Counter is enabled		2.5		KHz
DC_{PWM}	Output Valid Duty Cycle Range		10		90	%
TC	Turns Counter Range		-1024		1023	
TCstep	Turns Counter PWM Step Size			0.039		% / Turn
TC_PWM _Q	Quiescent Duty Cycle	Turns Counter = 0		50		%
TC_PWM _{QΔL}	Quiescent Duty Cycle Lifetime drift			0.5		%
TC _{noise}	RMS noise on PWM duty cycle of TURNS pin			0.005		%
T_{tc_start}	Minimum Time required to pull down the TURNS pin to initiate the turns counter				125	μs
T_{tc_reset}	Minimum Time required to pull down the TURNS pin to reset the turns counter				1.1	ms
T_{tc_delay}	Time delay from rising edge on TURNS pin to the first PWM falling edge			55		μs

- (1) V_{offset_room} is the differential offset voltage deviation from the target of 0mV.
- (2) The AGC rate initially starts at 4μs on power-up. When V_{OUT} crosses 60% of V_{CC} the updated rate switches to 1s.

5.6 Magnetic Characteristics

over operating free-air temperature range (unless otherwise noted); typical specifications are at TA = 25°C

PARAMETER		TEST CONDITIONS	MIN	TYP	MAX	UNIT
Angular Performance						
ANG _{ERR_DYN_SE}	Angular error linearity across temperature on continuous calibration (gain / offset) (single ended)	B = 30mT, V _{CC} = 3.3V, Magnetic field Rotation Speed = 1000rpm		0.1	0.35	deg
		B = 30mT, V _{CC} = 5V, Magnetic field Rotation Speed = 1000rpm		0.1	0.56	deg
ANG _{ERR_DYN_DE}	Angular error linearity across temperature on continuous calibration (gain / offset) (differential ended)	B = 30mT, V _{CC} = 3.3V, Magnetic field Rotation Speed = 1000rpm		0.1	0.4	deg
		B = 30mT, V _{CC} = 5V, Magnetic field Rotation Speed = 1000rpm		0.1	0.56	deg
ANG _{ERR_RTCAL_SE}	Angular error linearity across temperature after room temperature calibration (of offset / gain mismatch) (single ended)	B = 30mT, V _{CC} = 3.3V, Ideal magnet alignment		0.1	1.1	deg
		B = 30mT, V _{CC} = 5V, Ideal magnet alignment		0.1	1.1	deg
ANG _{ERR_RTCAL_DE}	Angular error linearity across temperature after room temperature calibration (of offset / gain mismatch) (differential ended)	B = 30mT, V _{CC} = 3.3V, Ideal magnet alignment		0.2	1.0	deg
		B = 30mT, V _{CC} = 5V, Ideal magnet alignment		0.1	0.95	deg
ANG _{ERR_NOCAL_SE}	Angular error linearity across temperature with no calibration of gain / offset (single ended)	B = 30mT, V _{CC} = 3.3V, Ideal magnet alignment		0.5	1.52	deg
		B = 30mT, V _{CC} = 5V, Ideal magnet alignment		0.5	1.26	deg
ANG _{ERR_NOCAL_DE}	Angular error linearity across temperature with no calibration of gain / offset (differential ended)	B = 30mT, V _{CC} = 3.3V, Ideal magnet alignment		0.4	1.1	deg
		B = 30mT, V _{CC} = 5V, Ideal magnet alignment		0.4	1.0	deg
ANG _{LT_DRIFT}	Angle error lifetime drift	B = 30mT		0.05	±0.75	deg
ANG _{HYST}	Angle hysteresis error	B = 30mT		0.01	0.06	deg
ANG _{OE_ERR}	Orthogonality error	B = 30mT		0.01	0.051	deg
ANG _{NOISE}	Angular RMS (1-sigma) noise in degrees	B = 30mT, C _{load} = 100pF		0.01	0.06	deg
t _{del_amr}	Propagation Delay time	C _{load} = 100pF		1.6		µs
BW _{3dB_amr}	3-dB Bandwidth	C _{load} = 100pF		100		KHz
φ _{err}	Phase error	Magnetic Field Rotation Speed = 10000rpm, C _{load} = 100pF		0.15		deg
Hall sensor characteristics						
B _{OP(X)} , B _{OP(Y)}	Magnetic field operating point			3		mT
B _{RP(X)} , B _{RP(Y)}	Magnetic field release point			-3		mT
B _{OP} - B _{RP}	Magnetic hysteresis			3.5	6	mT
B _{SYM_OP}	Operating point symmetry	B _{op(x)} – B _{op(y)}		±0.5		mT
B _{SYM_RP}	Release point symmetry	B _{rp(x)} – B _{rp(y)}		±0.5		mT
B _{SYM_RP}	Release point symmetry	B _{rp(x)} – B _{rp(y)}		0		mT
t _{PD_HALL}	Propagation delay time per channel	Change in B _{OP} or B _{RP} to change in output		10		µs

5.7 Typical Characteristics

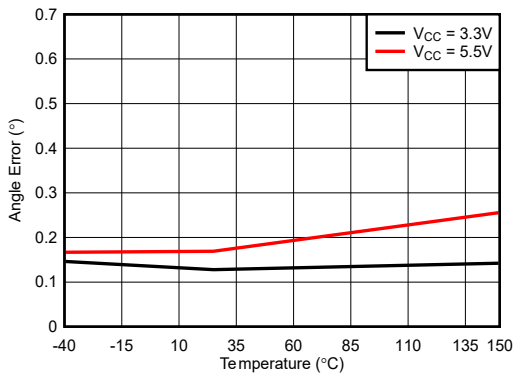

Figure 5-1. Absolute Angle Error. Differential with Dynamic Calibration

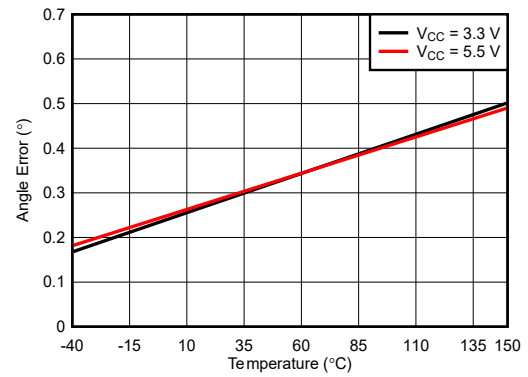

Figure 5-2. Absolute Angle Error. Differential with Room Temperature Calibration

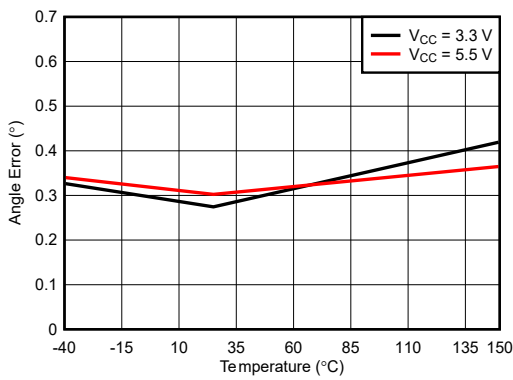

Figure 5-3. Absolute Angle Error. Differential with No Calibration

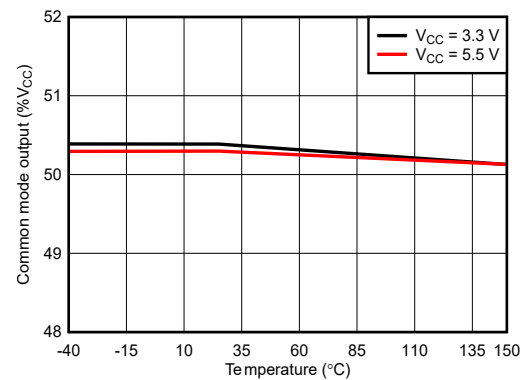

Figure 5-4. AMR Common-Mode Output Voltage

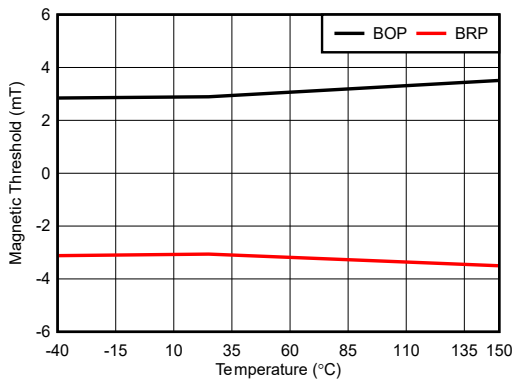

Figure 5-5. Hall Sensor BOP and BRP Typical Threshold

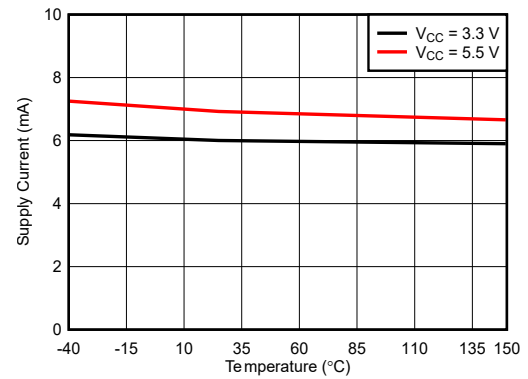
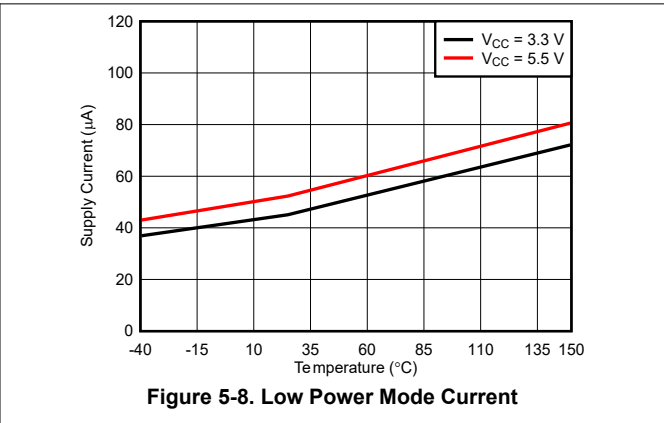
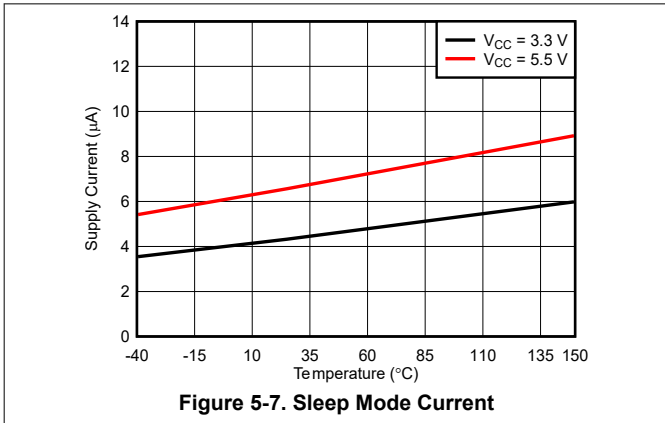

Figure 5-6. Active Mode Current

5.7 Typical Characteristics (continued)



6 Detailed Description

6.1 Overview

The TMAG6181-Q1 is a high-precision angle sensor based on the AMR sensor technology vertically integrated on top of the integrated amplifiers on silicon. The differential output sine and cosine signals from the AMR sensor are proportional to the angle of the applied magnetic field. They are internally signal conditioned, temperature compensated, and driven by differential output amplifiers with the ability to drive large capacitive loads. The output voltages of the AMR sensor are ratiometric to the supply voltage so the external ADC can use the supply voltage as a reference.

The TMAG6181-Q1 features a $\overline{\text{SLEEP}}$ pin to enable low power operation. The device integrates a rotation turns counter to measure the number of rotations of the external magnetic field using the integrated X and Y Hall sensors at a resolution of 90 degrees. The TURNS pin provides the integrated turns counter output using Pulse Width Modulation (PWM) scheme.

The TMAG6181-Q1 contains the following functional and building blocks:

- The Power Management and Oscillators block contains internal regulators, biasing circuitry, a low-frequency, wake-up oscillator and a high-frequency, wake-up oscillator, overvoltage and undervoltage detection circuitry
- The AMR sensor contains two Wheatstone bridges made of magnetic resistive sensors, each sensing one of the components of the applied magnetic field, the sine and the cosine components.
- The AMR sensing path contains the signal conditioning amplifiers, offset compensation, automatic gain control circuitry and the output drivers.
- The Turns Counting path contains the X and Y Hall sensors, related biasing circuitry, signal conditioning, logic comparators and a counter to keep track of rotations
- The Internal memory block supports the factory-programmed values
- The diagnostic blocks support background diagnostic checks of the internal circuitry

6.2 Functional Block Diagram

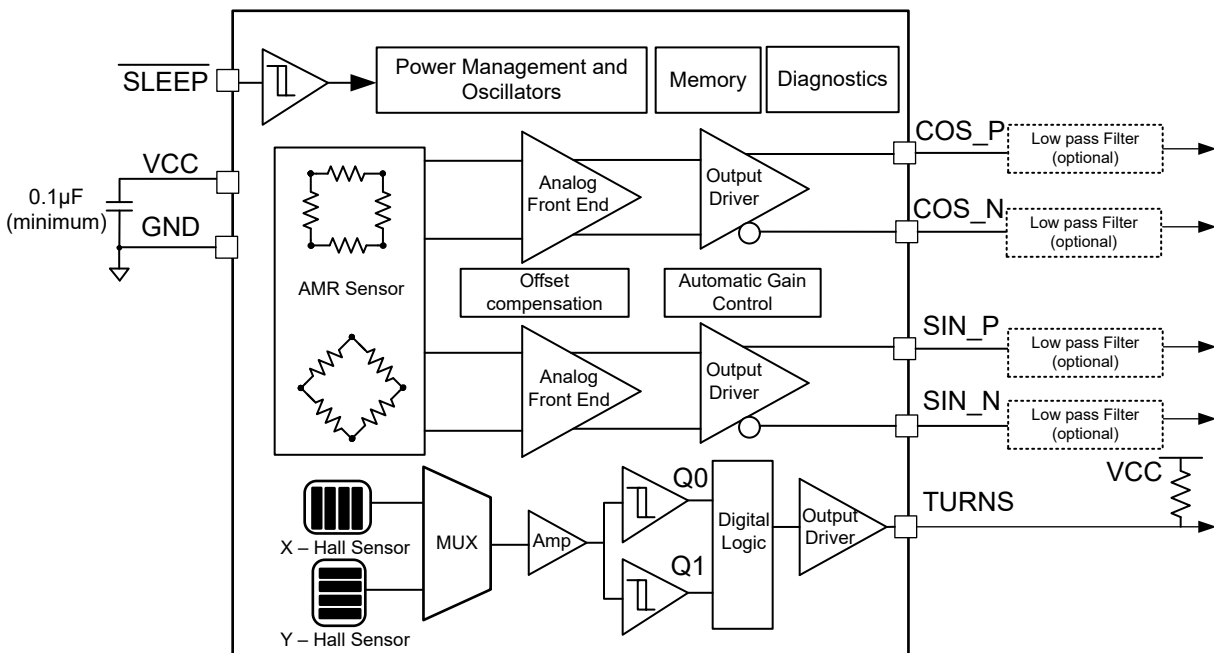

6.3 Feature Description

6.3.1 Magnetic Flux Direction

The TMAG6181-Q1 is sensitive to the magnetic field component in X and Y directions. The X and Y fields are in-plane with the package. The device generates sine and cosine outputs from the AMR based on the reference position (0°). See [Figure 6-1](#).

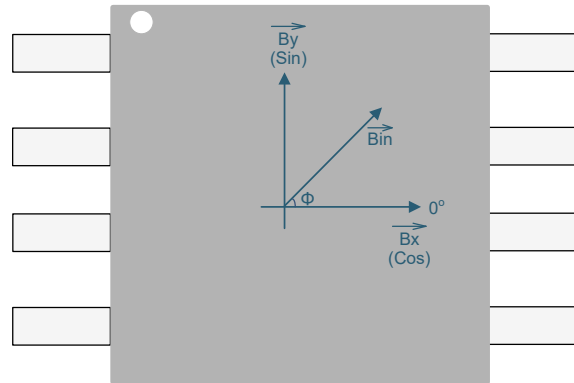

Figure 6-1. Direction of Sensitivity

6.3.2 Sensors Location and Placement Tolerances

Figure 6-2 shows the location of the AMR sensor and X, Y Hall elements, along with the placement tolerances inside the TMAG6181-Q1.

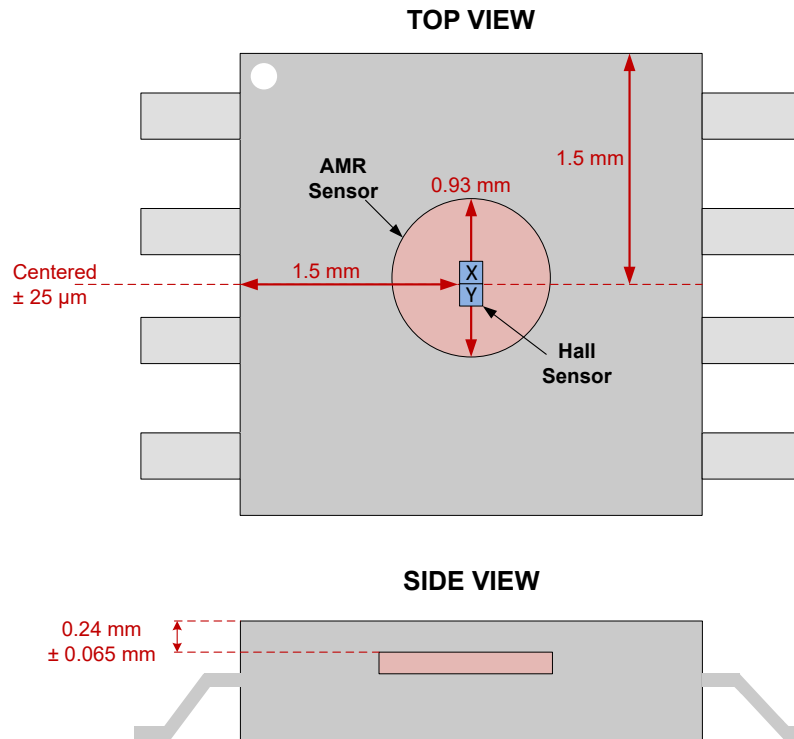

Figure 6-2. Location of AMR Sensor and Hall Elements

The center of the AMR and Hall sensors lie in the center of the package. Figure 6-3 shows the tolerances of the die rotation within the package. This causes a reference angle error (Φ) of $\pm 3^\circ$.

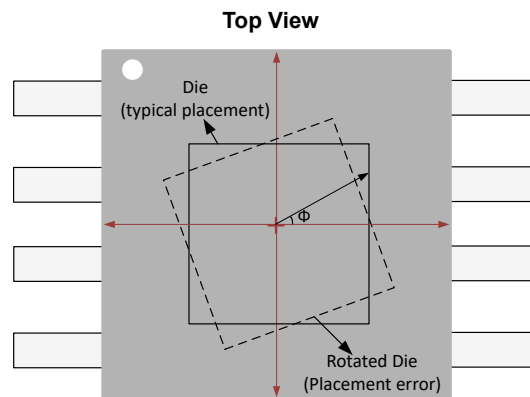

Figure 6-3. Die Rotation Tolerances in the Package

6.3.3 Magnetic Response

The AMR sensor has two components that are sensitive to the in-plane magnetic field X and Y axes parallel to the chip surface. Figure 6-4 shows the AMR sensor with the differential sine and cosine outputs SIN_P, SIN_N, COS_P and COS_N. The outputs have an electrical range of 180 degrees. If the mechanical angle between the sensor reference and the direction of the magnetic field is θ , then the AMR outputs correspond to cosine 2θ and sine 2θ , respectively. For every 360° rotation of the external magnetic field, the AMR outputs provide two periods at 180° sensing range for each period. Hence, for a dipole magnet rotating at speed of f , the electrical output from the AMR sensor outputs can be at twice the frequency at $2f$. Use Equation 1 to calculate the angle of the magnetic field using an arctangent2 function.

$$\theta = \frac{\arctan2\left(\frac{V_{\sin}}{V_{\cos}}\right)}{2} \quad (1)$$

where

- V_{\sin} is the sine output
- V_{\cos} is the cosine output

The AMR sensor is sensitive only to the direction of the magnetic field and has a wide operating magnetic field range. The voltage levels of the AMR outputs are independent of the absolute flux density as long as the magnetic flux density is above the minimum recommended operating fields.

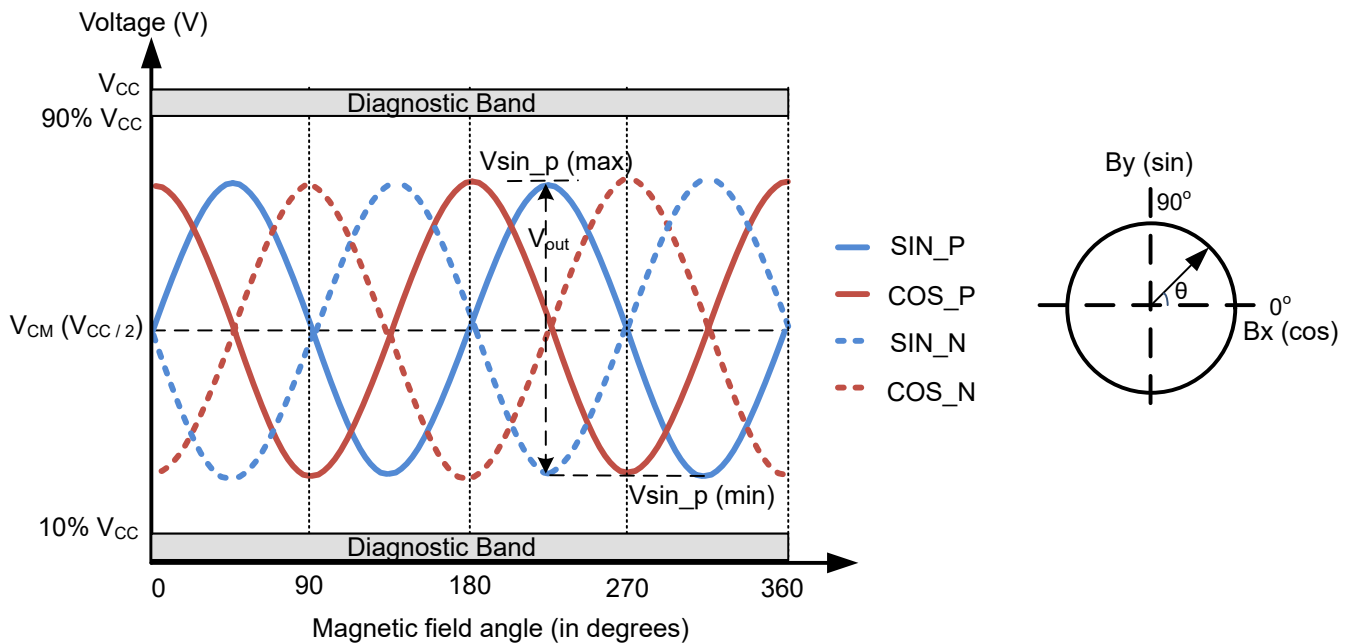

Figure 6-4. AMR Sensor Outputs Magnetic Response

Figure 6-5 shows the two integrated Hall sensors X and Y that are sensitive to the in-plane X and Y axes similar to the AMR sensor. The outputs Q1 and Q0 shows the digital outputs of both these sensors, respectively. Figure 6-5 shows both the Hall outputs reacting to the input field by going low when the field is higher than operating point (B_{OP}) and going high when the field is lower than returning point (B_{RP}).

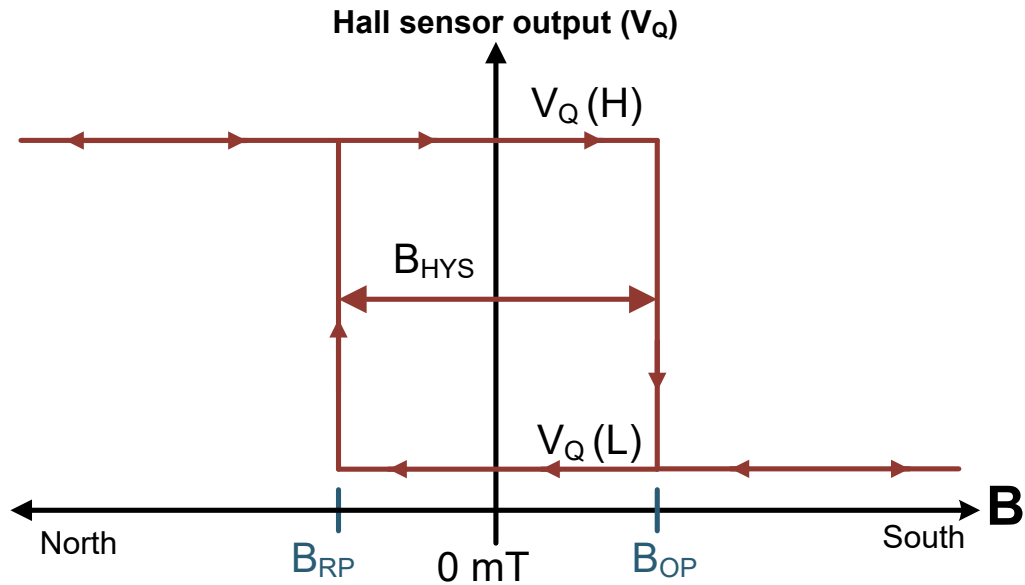

Figure 6-5. Hall Sensor Magnetic Response

For a rotating input magnetic field, with the Y and X components of B_{SIN} and B_{COS} respectively, [Figure 6-6](#) shows the response of the AMR and Hall sensors. The integrated X and Y Hall sensors provide digital outputs (Q1 and Q0, respectively). See the [Functional Block Diagram](#). The Hall sensors have a 360° angle range compared to the 180° angle range of the AMR sensors.

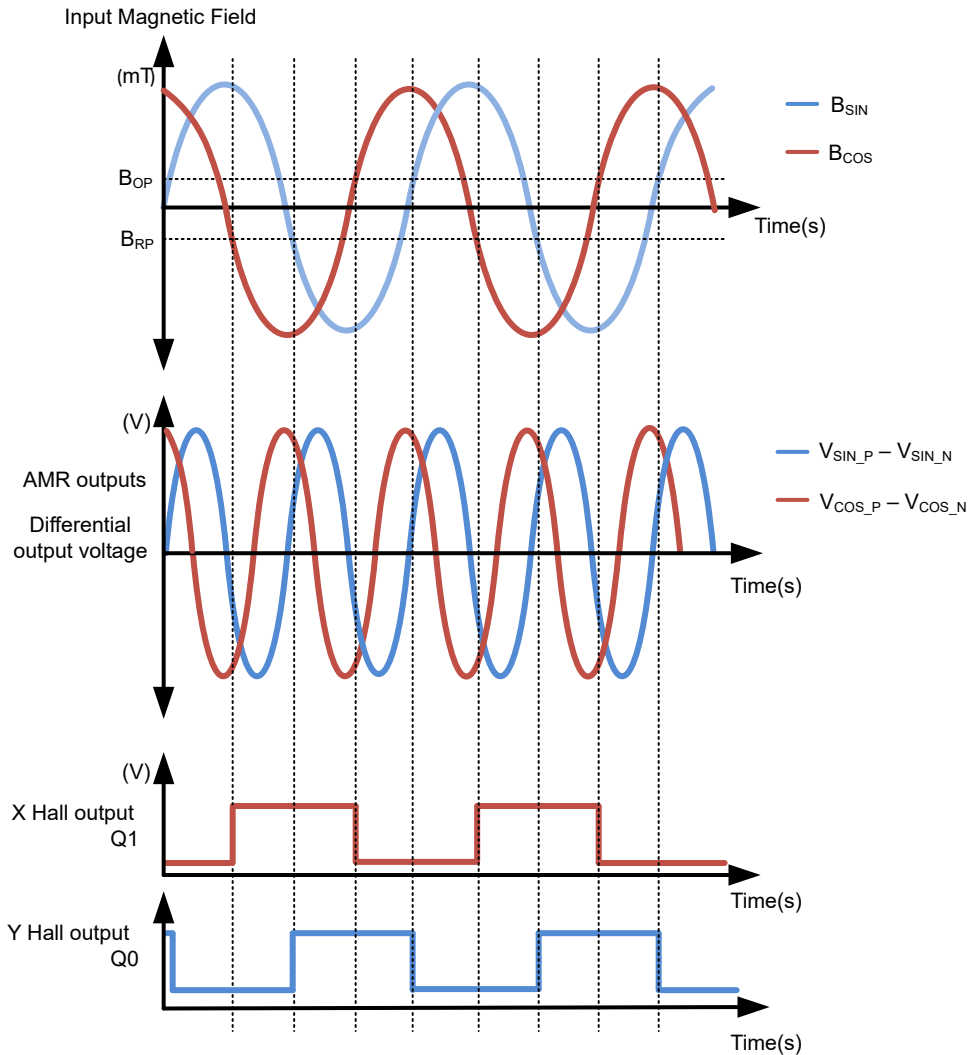

Figure 6-6. Magnetic Response of AMR and Hall Sensors

6.3.4 Parameters Definition

6.3.4.1 AMR Output Parameters

Magnetic Response shows the single-ended output signals as SIN_P, SIN_N, COS_P and COS_N. These signals are ratiometric to the supply voltage (V_{CC}). The common-mode voltage (V_{CM}) of the individual signals is half of the supply voltage ($V_{CC}/2$). For single-ended signals, V_{OUT} is defined as the difference between the maximum and minimum output voltage for a rotating magnetic field. Use [Equation 2](#) to calculate $V_{OUT_SIN_P}$.

$$V_{OUT_SIN_P} = V_{SIN_P(max)} - V_{SIN_P(min)} \quad (2)$$

where

- $V_{SIN_P(max)}$ is the maximum output voltage across the full magnetic angle range
- $V_{SIN_P(min)}$ is minimum output voltage across the full magnetic angle range

Typically, V_{OUT} is around 60% of the supply voltage (V_{CC}). The diagnostic band indicates that the output signals are outside normal operating range and indicates a presence of fault.

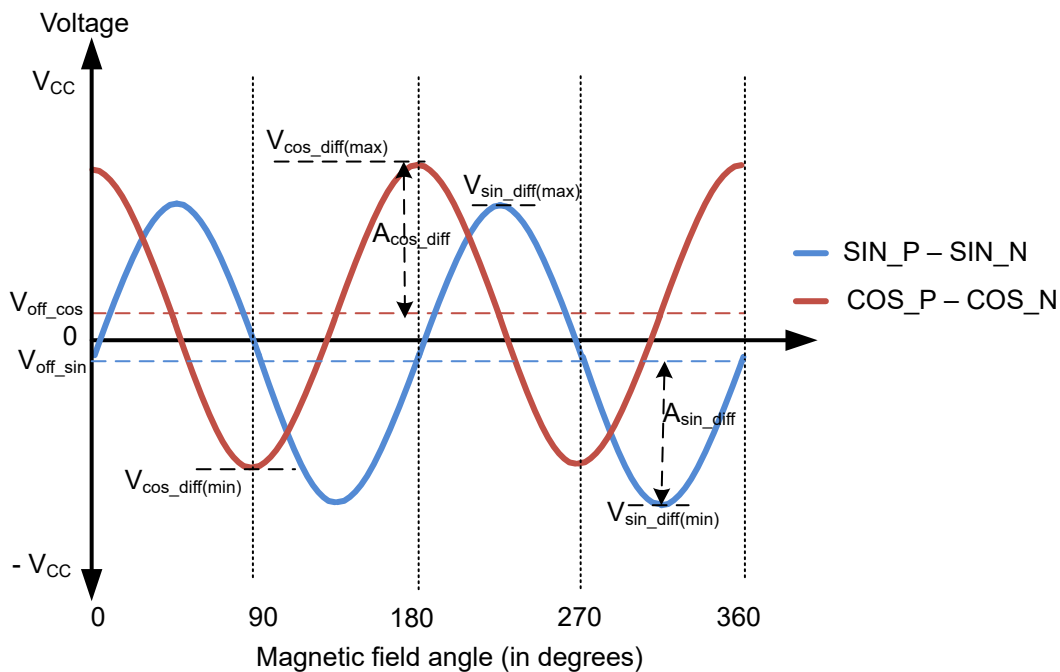

Figure 6-7. AMR Differential-Ended Output Signals

[Figure 6-7](#) shows the differential sine and cosine output signals generated from the corresponding sine and cosine single-ended outputs. Use [Equation 3](#) and [Equation 4](#) to calculate the differential voltages.

$$V_{sin_diff} = V_{SIN_P} - V_{SIN_N} \quad (3)$$

$$V_{cos_diff} = V_{COS_P} - V_{COS_N} \quad (4)$$

The offset of the differential signals is the average of the maximum and minimum voltages of the sine or cosine signals. Use [Equation 5](#) and [Equation 6](#) to calculate the offsets for the sine and cosine signals.

$$V_{offset_sin} = \frac{V_{sin_diff(max)} + V_{sin_diff(min)}}{2} \quad (5)$$

$$V_{offset_cos} = \frac{V_{cos_diff(max)} + V_{cos_diff(min)}}{2} \quad (6)$$

For single-ended signals, the offset is the common-mode voltage (V_{CM}).

Use [Equation 7](#) to calculate the differential offset for sine and cosine channels at any given temperature, T_A

$$V_{\text{offset}} = V_{\text{offset, room}} + V_{\text{offset_TC}} \times (T_A - 25^\circ\text{C}) \quad (7)$$

where

- $V_{\text{Offset_TC}}$ is the temperature drift coefficient of the offset
- $V_{\text{Offset_room}}$ is the room temperature offset

Use [Equation 8](#) and [Equation 9](#) to calculate the amplitudes of the differential signals.

$$A_{\text{sin_diff}} = \frac{V_{\text{sin_diff(max)}} - V_{\text{sin_diff(min)}}}{2} \quad (8)$$

$$A_{\text{cos_diff}} = \frac{V_{\text{cos_diff(max)}} - V_{\text{cos_diff(min)}}}{2} \quad (9)$$

Use [Equation 10](#) to calculate the amplitude for single-ended signals.

$$A_{\text{sin_p}} = \frac{V_{\text{sin_p(max)}} - V_{\text{sin_p(min)}}}{2} \quad (10)$$

Amplitude asynchronism refers to the amplitude mismatch error between sine and cosine channels. Use [Equation 11](#) to calculate the amplitude mismatch error.

$$k = 1 - \left(\frac{A_{\text{cos_diff}}}{A_{\text{sin_diff}}} \right) \quad (11)$$

The sine and cosine output signals are typically out-of-phase by 90 degrees, but if an internal phase error occurs owing to sensor and other on chip circuitry non-idealities, the sine and cosine outputs from the sensor can be different than the ideal 90 degrees. This error is referred to as the orthogonality error. This error is defined as the angle error between the zero crossing of the cosine output and maximum value of the sine outputs.

The hysteresis error (ANG_{hyst}) refers to the largest angle error difference between a clockwise rotation and a counter-clockwise rotation.

For the AMR sensor, the orthogonality error and the hysteresis errors are negligible.

6.3.4.2 Transient Parameters

Propagation delay (t_{del_amr}) is defined as the time taken for signal to propagate from magnetic input change to the sine and cosine AMR outputs. The bandwidth limitation of the internal signal conditioning amplifiers causes a phase shift on the applied magnetic field. The propagation delay increases based on the speed of the rotating field and is specified at the maximum speed of the recommended magnetic field. Figure 6-8 shows an input rotating magnetic field and the response of the AMR outputs. The propagation delay leads in the signal path leads to a phase error.

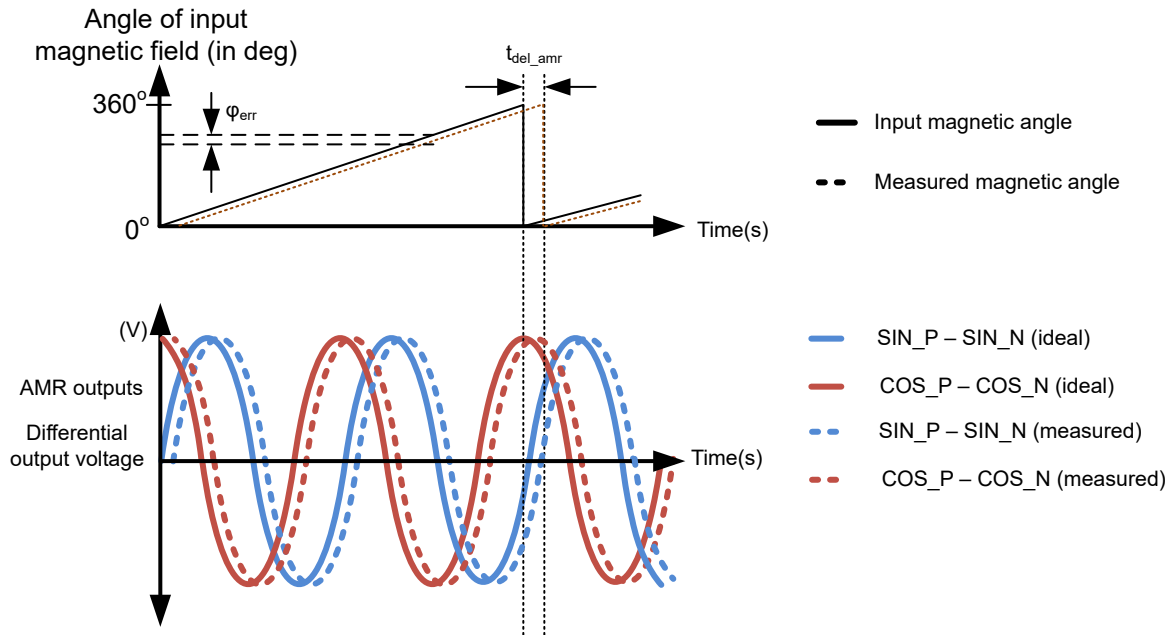

Figure 6-8. AMR Output Propagation Delay and Phase Error

The phase error (ϕ_{err}) refers to the angle error between the input magnetic field and output of the sensor. This error increases with the speed of the rotating magnetic field and the propagation delay of the AMR sensor. Typically this error can be compensated to the first order if the speed of the rotating magnetic field is known.

6.3.4.2.1 Power-On Time

The power-on time during start-up ($T_{on_startup}$) is defined as the time for the AMR outputs to reach to 90% of the final value (under a constant magnetic field) after the V_{CC} reaches $V_{CC(min)}$. Figure 6-9 shows the power-on time of the device when the \overline{SLEEP} pin is tied to V_{CC} during a V_{CC} ramp.

Figure 6-9. Power-On Time During Start-Up

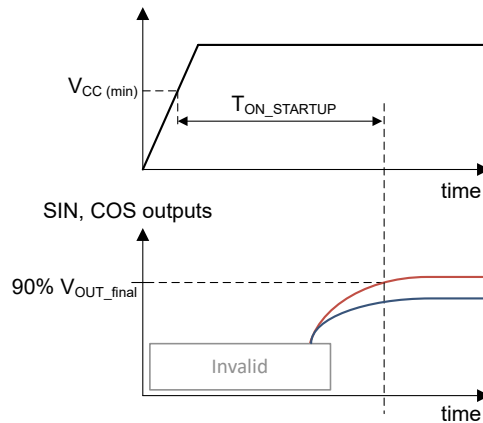

The power-on time from sleep mode (T_{on_sleep}) is defined as the time for the AMR outputs to reach to 90% of the final value (under a constant magnetic field) after the \overline{SLEEP} reaches above V_{IH_SLEEP} . Figure 6-10 shows the power-on time of the device when the \overline{SLEEP} pin is ramped high when the V_{CC} is held constant.

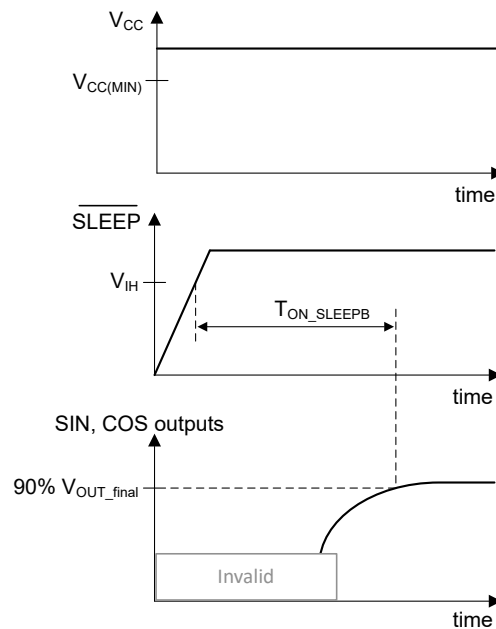

Figure 6-10. Power-On Time When \overline{SLEEP} is Pulled High

6.3.4.3 Hall Sensor Parameters

The Hall sensors X and Y have factory-calibrated operating (B_{OP}) and release points (B_{RP}). The operating and release points shown in Figure 6-4 give the magnetic hysteresis for each Hall sensor.

Use Equation 12 and Equation 13 to calculate the symmetry point for each axis.

$$B_{SYM(X)} = B_{OP(X)} + B_{RP(X)} \quad (12)$$

where

- $B_{OP(X)}$ and $B_{RP(X)}$ represent the operating and release points for X Hall sensor

$$B_{SYM(Y)} = B_{OP(Y)} + B_{RP(Y)} \quad (13)$$

where

- $B_{OP(Y)}$ and $B_{RP(Y)}$ represent the operating and release points for Y Hall sensor

Use Equation 14 to calculate the operating point symmetry.

$$B_{SYM_OP} = B_{OP(X)} - B_{OP(Y)} \quad (14)$$

Use Equation 15 to calculate the release point symmetry.

$$B_{SYM_RP} = B_{RP(X)} - B_{RP(Y)} \quad (15)$$

6.3.4.4 Angle Accuracy Parameters

The overall angle error represents the relative angular error. Figure 6-11 shows the deviation from the reference line after zero angle definition.

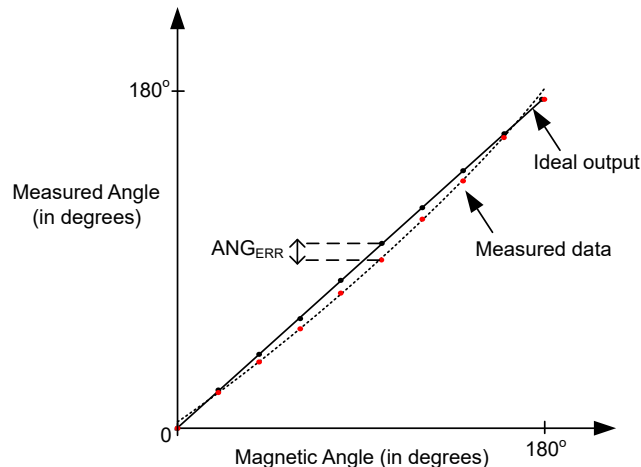

Figure 6-11. Angle Error

The uncalibrated angular error ($ANG_{ERR_NOCAL_DE}$) is defined as the maximum deviation from an ideal angle without any offset and amplitude mismatch calibration for the VSIN and VCOS differential signals. For single-ended signals, the uncalibrated angular error is denoted by $ANG_{ERR_NOCAL_SE}$.

The single point calibration angular error ($ANG_{ERR_RTCAL_DE}$) is defined as the maximum deviation from an ideal angle after the offset calibration is applied to the VSIN and VCOS differential signals at room temperature (25°C). For single-ended signals, the room temperature offset calibrated angular error is denoted by $ANG_{ERR_RTCAL_SE}$.

The dynamic angular error (ANG_{ERR_DYN}) is defined as the maximum deviation from an ideal angle with the continuous offset and gain calibration applied to the VSIN and VCOS differential signals. The error is measured at 1krpm and includes the phase error owing to the propagation delay of the AMR outputs.

6.3.5 Automatic Gain Control (AGC)

To reduce the drift of the AMR sensor outputs across temperature, the TMAG6181-Q1 features an automatic gain control circuitry where the device changes the gain of the output drivers to keep the final output within an appropriate voltage range on SIN_P, SIN_N, COS_P and COS_N. The AGC block uses the square root of the sum of the squared amplitudes of the two channels to sense amplitude of output signals and set gain selection. This means that the AGC block sets the gain for sine and cosine channels such that the peak-to-peak amplitude of single-ended voltages (V_{OUT}) is within the range listed in [Specifications](#). The AGC block changes the gain of both the sine and cosine channels simultaneously and does not affect the angle accuracy.

If the outputs are out of the intended operating range, the AGC block changes the gain of the sine and cosine channels by a step size of $\pm 1\% V_{CC}$ at an interval of t_{agc_update} , approximately one second, as defined in [Specifications](#). [Figure 6-12](#) shows the differential AMR outputs for a continuously rotating input field. The shaded area represents the 'No AGC Control' band that represents $\pm 5\%$ of V_{CC} and is centered at 60% of V_{CC} . Notice that the AGC loop reduces the gain of the sine and cosine channels and updates the amplitude of the sine and cosine signals when drift outside of the shaded region at a step size of $1\% V_{CC}$. If the outputs remain within the shaded region, then no action is taken by the AGC control loop.

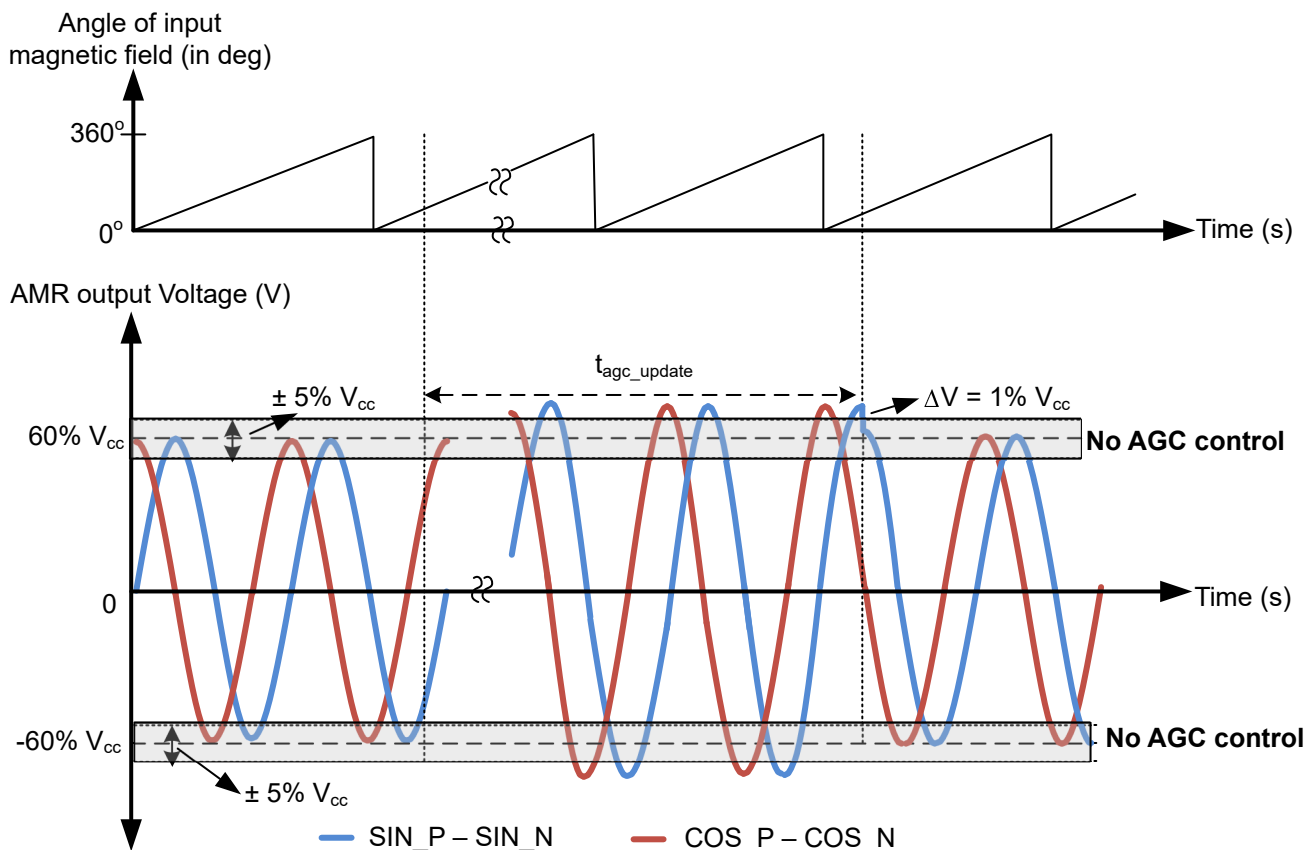

Figure 6-12. Timing Diagram Showing the Operation of Automatic Gain Control

6.3.6 Turns Counter

The TMAG6181-Q1 features an integrated 11-bit turns counter that can be used to keep track of rotation counts in different modes of operation (see [Device Functional Modes](#)). [Figure 7-2](#) shows the typical application diagram when the turns counter is used in the system. The turns counter can be initiated and reset using the open-drain TURNS pin.

The turns counter uses the integrated X and Y Hall sensors to detect the rotation. The outputs from the Hall sensors are sampled at an interval of t_{tc_update} to update the turns counter. The turns counter can detect a change in the applied magnetic field at a resolution of 90° with a range of 360° . The turns counter also keeps track of direction information. The counter is incremented if the applied field is rotated clockwise and decremented if the field is rotated counter-clockwise. [Figure 6-13](#) shows the counter operation based on the rotation of the input magnetic field.

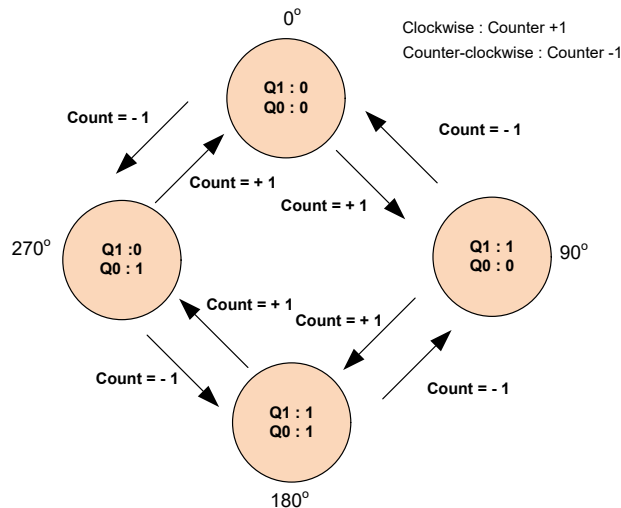

Figure 6-13. Turns Counter Operation

The turns counter information is sent using the TURNS pin in a Pulse Width Modulation (PWM) format. [Figure 6-14](#) shows the PWM duty cycle variation based on the turns counter value. The typical pulse-width modulation (PWM) carrier frequency is 2.5kHz. When the counter value is 0, the TURNS pin outputs a 50% duty cycle.

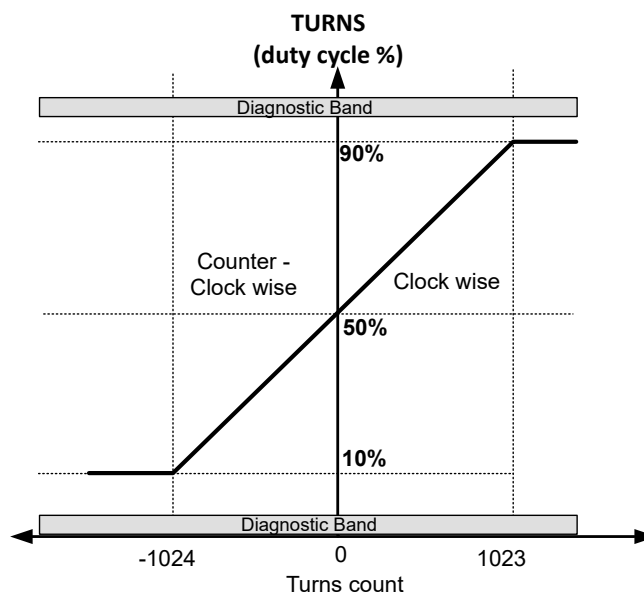

Figure 6-14. Turns Counter PWM Output on TURNS Pin

Figure 6-15 shows the timing diagram to enable the turns counter in active mode. When the part powers up, the turns counter is not enabled by default. The turns counter can be enabled by holding the TURNS pin low, for at least t_{tc_start} . When the TURNS pin is released, the pin turns into the output mode and sends out the PWM pulses corresponding to the internal turns counter after a time delay of t_{tc_delay} , as provided in the [Specifications](#). To reset the counter and disable the output on TURNS pin, TURNS is pulled low for at least $t > t_{tc_reset}$. When the turns counter is enabled in the active mode, the internal wake-up oscillator is used to enable the Hall sensor signal path at regular intervals to update the turns counter information. This allows the device to keep the turns counter feature on at a lower power consumption overhead.

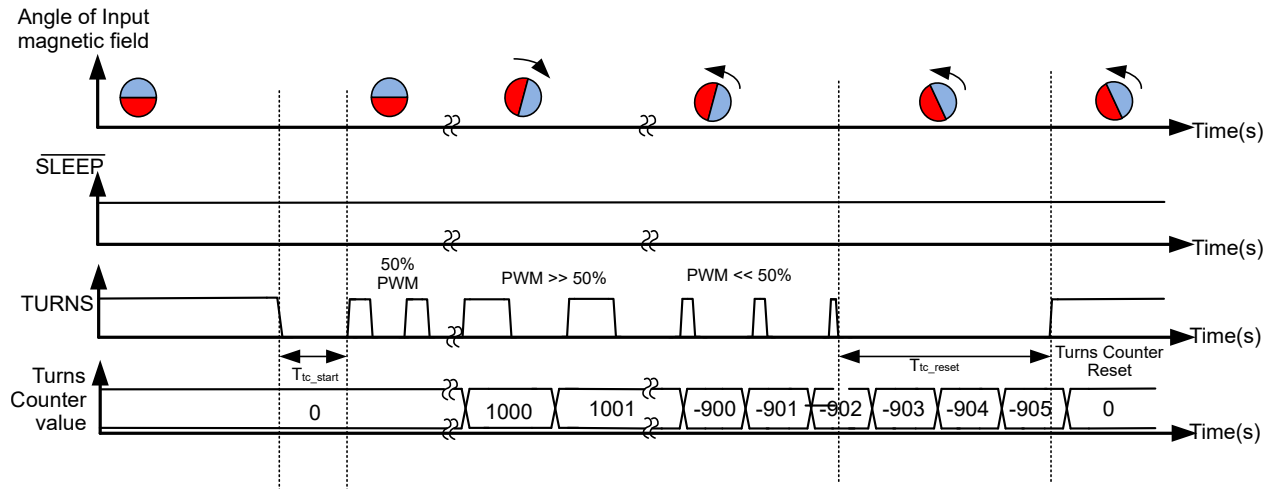

Figure 6-15. Timing Diagram Showing the Turns Counter Operation in Active Mode

Figure 6-16 shows the timing diagram of the turns counter operation in low-power mode. The part can be placed in a low-power, duty-cycled state if the turns counter is enabled. During this low-power state, an internal wake-up oscillator is used to wake up the device at regular intervals, t_{sleep} . When the part wakes up, the integrated Hall sensor signals are monitored for a rotation, and the turns counter information is updated. The TURNS pin does not output the PWM pulses during this low-power state. When the part is moved into an active state from the low-power state, the PWM pulses corresponding to the turns counter information saved during the low-power state is sent out to the microcontroller.

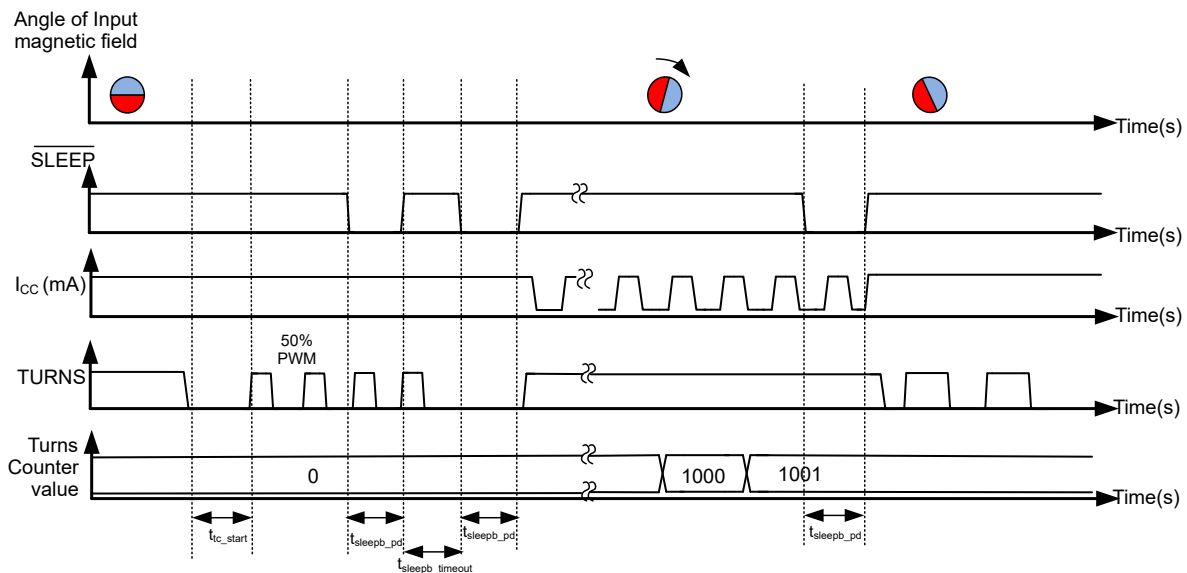

Figure 6-16. Timing Diagram Showing the Turns Counter Operation in Low-Power Mode

6.3.6.1 Rotation Tracking

The TMAG6181-Q1 has a rotation tracking feature to track high-speed rotations at low current consumption to save power. This feature lets the device decrease the sleep time when magnetic field rotations are detected, and enables the device to track the higher speed and acceleration events. When the turns counter is enabled using the TURNS pin, the rotation tracking feature is also enabled. This feature is enabled in both the active-turns mode and the low-power mode (see [Device Functional Modes](#)).

In active mode, when the turns counter is enabled, the Hall sensor signals are monitored approximately every 1.6ms. But when a rotation is detected, the period between the next wake-up event is reduced by 1/8th to 0.2ms. If no rotation change is detected for four consecutive periods, then the sleep time is increased to 0.4ms. If new rotations are detected, then the tracking algorithm goes to 0.2ms and the counter for the four consecutive periods is reset. If no rotations are detected in next four consecutive periods, then the sleep time is doubled again to 0.8ms and then eventually back to 1.6ms if no more rotations are detected. After reaching this default value of 1.6ms, the rotation tracking feature allows the TMAG6181-Q1 to continue sampling at this fixed period until new rotations are detected.

In low-power mode, when the turns counter is enabled, the Hall sensor signals are monitored approximately every 25.6ms. But when a rotation is detected, the period between the next wake-up event is reduced by 1/16th to 1.6ms. If no rotation change is detected for four consecutive periods, then the sleep time is increased to 3.2ms. If new rotations are detected, then the tracking algorithm goes to 1.6ms and the counter for the four consecutive periods is reset. If no rotations are detected in the next four consecutive periods, then the sleep time is doubled again to 6.4ms and then to 12.8ms after the next four cycles. After reaching the default value of 25.6ms, the rotation tracking feature allows the TMAG6181-Q1 to continue sampling at this fixed period until new rotations are detected. [Figure 6-17](#) shows the rotation tracking feature during low-power mode.

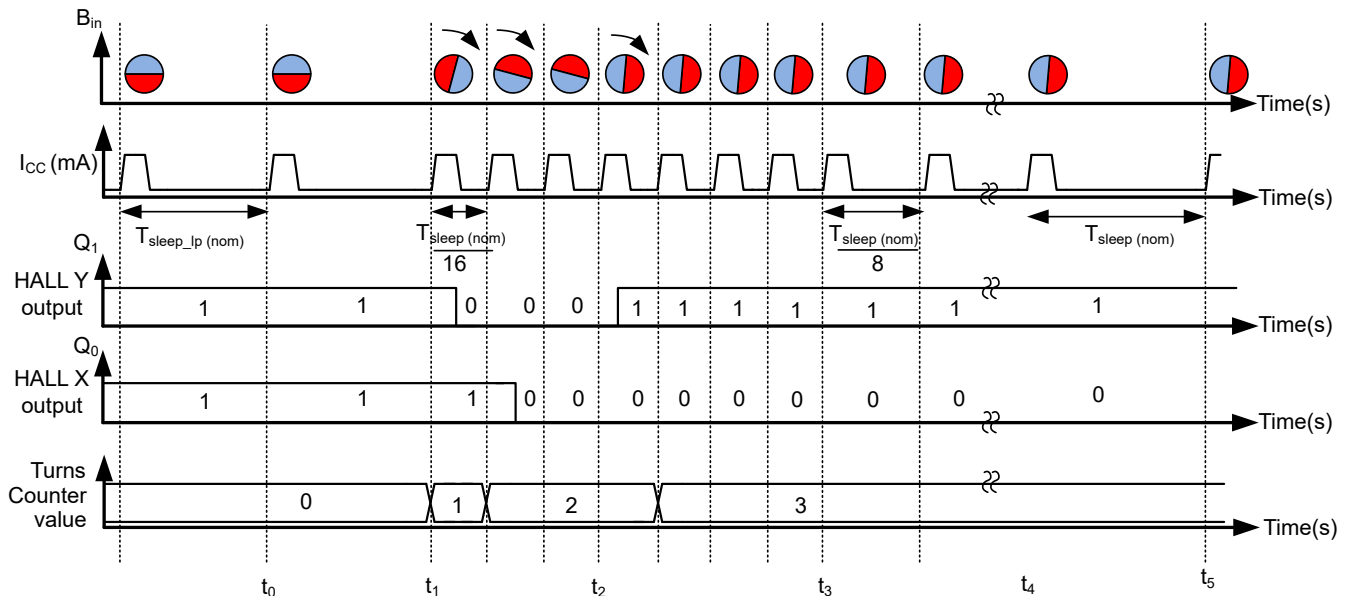

Figure 6-17. Timing Diagram Showing the Rotation Tracking Feature in Low Power Mode

Use [Equation 16](#) to calculate the maximum angle travel, θ , for a rotating magnetic field.

$$\theta = 6[(v \times t) + (0.5 \times a \times t^2)] \tag{16}$$

where,

- t is the field travel time
- v is the velocity of the moving field in rpm
- a is the acceleration of the moving field in rpm/second

The turns counter has an angle resolution of 90°. The turns counter can successfully track the rotations if the counter ensures the state transitions (as shown in [Figure 6-13](#)) and does not jump any states. At an acceleration of 6000rpm/sec, the rotation tracking feature enables the device to track up to 8000rpm during low-power mode and in active-turns mode, and enables at track up to 60000rpm.

[Table 6-1](#) shows the trade-off between maximum speed (in rpm) that can be tracked by the turns counter and the current consumption in active mode.

Table 6-1. Maximum Trackable rpm vs Average Current Consumption in Active Mode

OPERATING MODE	SLEEP TIME (ms)	MAX TRACKABLE rpm (TYP)	AVERAGE CURRENT (μ A)
Active-turns mode	0.2	62500	472
	0.4	31250	280
	0.8	15625	167
	1.6 (default)	7812	105

[Table 6-2](#) shows the trade-off between maximum speed (in rpm) that can be tracked by the turns counter and the current consumption in low-power mode

Table 6-2. Maximum Trackable rpm vs Average Current Consumption in Low Power Mode

OPERATING MODE	SLEEP TIME (ms)	MAX TRACKABLE rpm (TYP)	AVERAGE CURRENT (ILP) (μ A)
Low-power mode	1.6	7812	105
	3.2	3905	73
	6.4	1950	57
	12.8	970	48
	25.6 (default)	475	44

6.3.7 Safety and Diagnostics

The TMAG6181-Q1 supports several device and system level diagnostics features to detect, monitor, and report failures during the device operation.

In the event of a failure, the TMAG6181-Q1 is placed in a FAULT state, where the outputs from the AMR sensors are placed in a high-impedance state. See [Device Functional Modes](#) for fault state transition from different operation modes. As shown in the [Application and Implementation](#) section, users can add pullup or pulldown resistors on SIN_P, SIN_N, COS_P, and COS_N pins at the termination site (that is the microcontroller). The resistors are generally pulled up to supply voltage or pulled down to ground such that the ADC code on MCU is out of expected range. This state signal faults to the microcontroller.

The integrated turns counter has a valid range of 10% to 90% PWM output. If a fault is detected in the turns counter, then the output of the turns counter is at >95% PWM or <5% PWM. The external microcontroller can monitor if the turns counter is within expected range.

The TMAG6181-Q1 performs the following device and system level checks:

6.3.7.1 Device Level Checks

- AMR signal path checks
 - AMR sensor bias check
 - AMR output signals common mode check
 - Automatic gain control loop check
- Hall sensor signal path checks
 - Hall sensor bias and resistance check
 - Hall sensor comparator check
- Turns counter overflow check
- Power management and supporting circuitry checks
 - Internal LDO undervoltage check
 - Internal clocks integrity check
- Internal memory integrity check (or a cyclic redundancy check–CRC)

6.3.7.2 System Level Checks

- V_{CC} undervoltage and overvoltage checks
- Pin level opens and short checks

6.4 Device Functional Modes

6.4.1 Operating Modes

The TMAG6181-Q1 supports multiple operating modes for a wide array of applications as explained in Figure 6-18. The device starts powering up after the V_{CC} supply crosses the minimum threshold as specified in the Recommended Operating Conditions table.

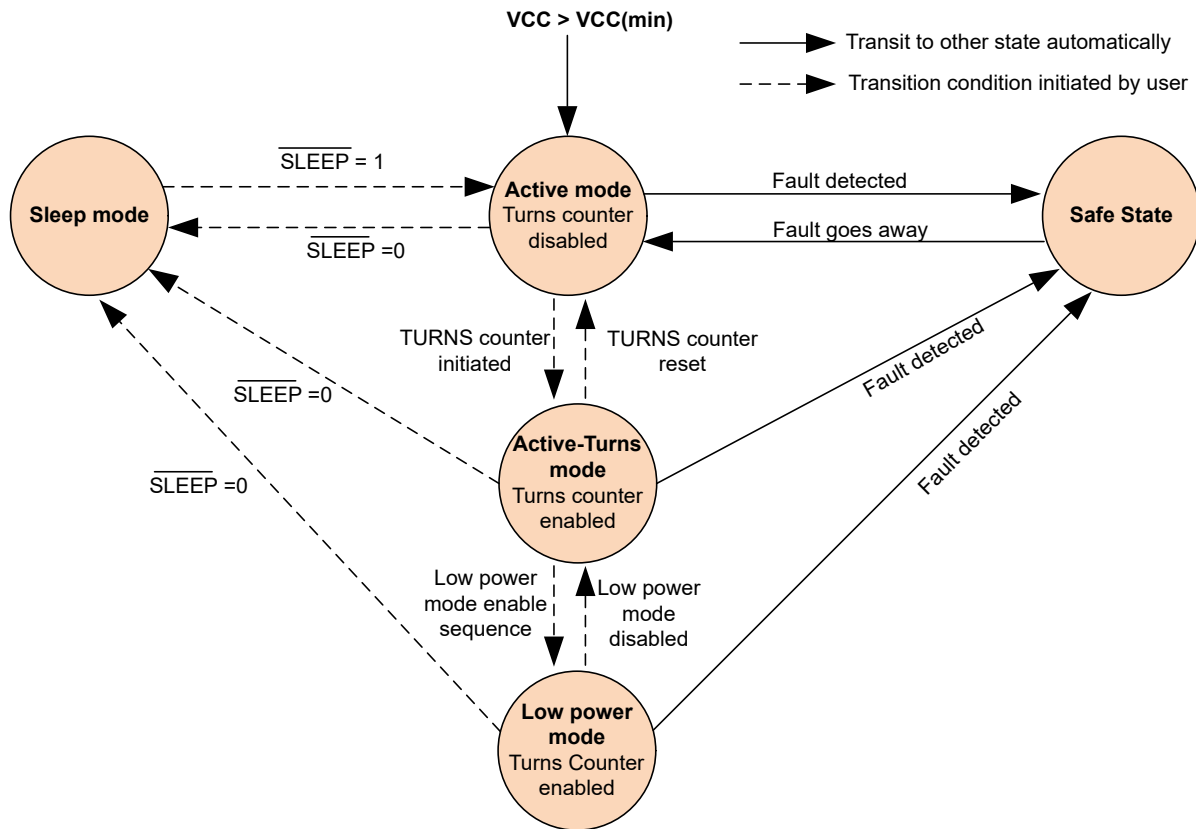

Figure 6-18. TMAG6181-Q1 State Transition Diagram

Table 6-3 shows the different operating modes of the TMAG6181-Q1.

Table 6-3. TMAG6181-Q1 Operating Modes

OPERATING MODE	DEVICE FUNCTION	AMR OUTPUT STATE	TURNS PIN (I/O FUNCTIONALITY) ⁽¹⁾
Active mode	AMR outputs track the magnetic field direction	Outputs in normal operating range	I
Active-turns mode	AMR outputs track the magnetic field direction and the TURNS pin sends out the internal turns counter information using PWM	Outputs in normal operating range	I / O
Low-power mode	Wakes up at a certain interval and the turns counter keeps track of changes in X and Y Hall sensor state	High Impedance	N/A
Sleep mode	Device enters the lowest power state	High Impedance	N/A
Fault (safe) mode	Device has detected a fault condition	High Impedance	N/A

(1) I = Input, O = Output, I/O = Input/ Output, N/A = Not Available

6.4.1.1 Active Mode

After power up, if the $\overline{\text{SLEEP}}$ is pulled high, the TMAG6181-Q1 enters active mode where the SIN_P, SIN_N, COS_P, and COS_N outputs actively provide the angle of the applied magnetic field. In this mode, the turns counter is disabled and the TURNS pin does not provide the PWM output. The average current consumption during the active conversion is I_{ACT} .

6.4.1.2 Active-Turns Mode

In this mode, the AMR sensor outputs are active and the turns counter is enabled. In this mode, the TURNS pin acts as a I/O and provides the counter information using the PWM output. In this mode, the Hall sensors are enabled and the outputs are monitored to update the turns counter. To enter this mode, the TURNS pin is pulled low for $t > t_{\text{tc_start}}$. [Figure 6-15](#) shows the sequence to enter active-turns mode. After the TURNS pin is released, the falling edge of the first PWM pulse occurs after $t_{\text{tc_start}}$. To exit this mode, the TURNS pin is pulled low for $t > t_{\text{tc_reset}}$ as defined in the [Specifications](#) section. After the turns counter is reset, the part goes back into active mode.

6.4.1.3 Low-Power Mode

The TMAG6181-Q1 can enter into low-power mode after the turns counter is enabled. During this mode, the turns counter is active and the wake-up oscillator is used to wake the device at a regular interval, T_{sleep} . During this mode, the TURNS pin does not send out the PWM information and the input path is disabled. The average current consumption during this mode is denoted by I_{LP} .

[Figure 6-16](#) shows the sequence to enter and exit low-power mode from active-turns mode. To enter low-power mode, two consecutive pulses are provided on the $\overline{\text{SLEEP}}$ pin. The pulses must be within the range of $t_{\text{sleep_pd}}$ as provided in the [Specifications](#) section. The timeout between these two consecutive pulses is defined by $t_{\text{sleep_timeout}}$ in the [Specifications](#) section. To exit low-power mode, the part monitors for a rising edge on the $\overline{\text{SLEEP}}$ pin. This can be provided by driving the $\overline{\text{SLEEP}}$ at a pulse width identical to the one used to enter low-power mode.

During low-power mode, an internal wake-up oscillator is used to wake the device up at regular intervals to monitor the states of the Hall sensors. During low-power mode, the rotation tracking feature is enabled to track rotations up to 8krpm at a very low power consumption. The period between two consecutive wake-up intervals is dependent on the frequency of the applied magnetic field (see [Rotation Tracking](#)).

6.4.1.4 Sleep Mode

Sleep mode can place the device in the lowest current consumption state. When the voltage on $\overline{\text{SLEEP}}$ pin goes below V_{IL} and stays low for longer than $t_{\text{sleep_mode}}$, then the part enters sleep mode. The average current consumption during this mode is denoted by I_{SLEEP} , and this mode uses approximately ten times less current compared to low-power mode. The part exits sleep mode when the voltage on the $\overline{\text{SLEEP}}$ pin goes above V_{IH} .

There is a 500k Ω pulldown resistor on the $\overline{\text{SLEEP}}$ pin and, when the $\overline{\text{SLEEP}}$ pin left floating, the part enters the sleep mode. TI recommends to ensure the $\overline{\text{SLEEP}}$ pin is driven externally to a known logic state.

6.4.1.5 Fault Mode

The TMAG6181-Q1 supports extensive fault diagnostics as detailed in [Diagnostics](#) section. When a fault is detected, the part enters fault mode. In this mode, the AMR outputs are placed in a high-impedance state.

7 Application and Implementation

Note

Information in the following applications sections is not part of the TI component specification, and TI does not warrant its accuracy or completeness. TI's customers are responsible for determining suitability of components for their purposes, as well as validating and testing their design implementation to confirm system functionality.

7.1 Application Information

7.1.1 Power Supply as the Reference for External ADC

The AMR output signals of the TMAG6181-Q1 are ratiometric to the supply voltage, V_{CC} . This enables the external ADC to use the TMAG6181-Q1 supply voltage as a reference and eliminate the errors that can arise if a separate reference voltage is used. This also enables to optimize the external ADC input range. TI therefore recommends to use the supply voltage (V_{CC}) as the reference for the external ADCs. To ensure the noise on the power supply is minimized, TI recommends using a 0.1 μ F bypass capacitor.

7.1.2 AMR Output Dependence on Airgap Distance

The AMR sensor is only sensitive to the direction of the applied magnetic field along the X-Y plane parallel to the chip surface. The applied magnetic field from a rotating magnet can vary based on the airgap distance between the TMAG6181-Q1 and the magnet.

As long the absolute field magnetic field is above the minimum field listed in *Recommended Operating Conditions*, the angle accuracy from the AMR outputs are independent of the value of the applied magnetic field.

7.1.3 Calibration of Sensor Errors

The TMAG6181-Q1 is factory-calibrated for the best angular accuracy. Some of the electrical errors from the sensor that impact the angle accuracy can be calibrated out for achieving the best performance. Figure 7-1 shows the impact of the different sensor error parameters such as offset, amplitude mismatch and orthogonality error on the angle accuracy.

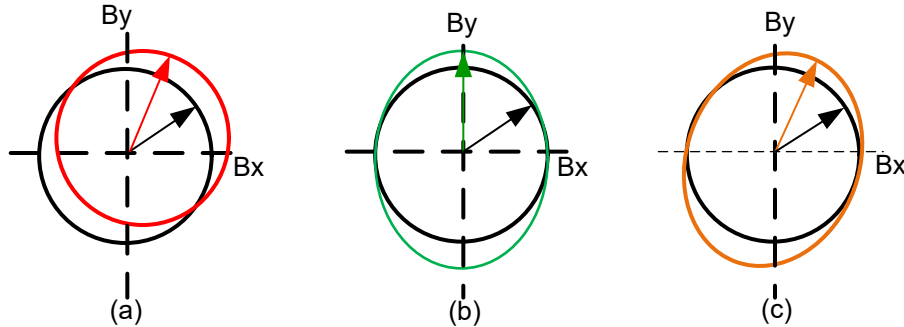

Figure 7-1. Angle Accuracy Impact Owing to Sensor Electrical Errors (a) Offset Error (b) Amplitude Mismatch Error (c) Orthogonality Error

Based on the parameters defined in [AMR Output Parameters](#), the angle from the AMR sensors is given by [Equation 17](#):

$$\theta = \frac{\arctan2\left(\frac{A_{\sin} \sin(2\theta) + V_{\text{offset_sin}}}{A_{\cos} \cos(2\theta) + V_{\text{offset_cos}}}\right)}{2} \quad (17)$$

where

- $V_{\text{offset_sin}}$ and $V_{\text{offset_cos}}$ are the differential offsets of the sine and cosine outputs
- A_{\sin} and A_{\cos} are the differential amplitude of the sine and cosine outputs

The impact of the angle accuracy owing to the orthogonality error and the hysteresis errors is negligible for the TMAG6181-Q1 and can be ignored.

To calibrate the offset and amplitude mismatch errors, the magnetic field rotates over the entire range and the sine and cosine outputs are sampled continuously to obtain the minimum and maximum values of the outputs.

Users can calculate the average of the minimum and maximum values of the respective outputs across the full angle range to find the offset error of the sine and cosine outputs. Use [Equation 18](#) and [Equation 19](#) to calculate the offset correction parameters for sine and cosine.

$$V_{\text{os_sin_cal}} = \frac{V_{\sin(\text{max})} + V_{\sin(\text{min})}}{2} \quad (18)$$

$$V_{\text{os_cos_cal}} = \frac{V_{\cos(\text{max})} + V_{\cos(\text{min})}}{2} \quad (19)$$

Users can calculate the difference of the minimum and maximum values of the respective outputs across the full angle range to find the amplitude of the sine and cosine outputs. Use [Equation 20](#) to calculate the amplitude correction parameters for sine and cosine.

$$A_{\text{corr}} = 1 - \frac{V_{\sin(\text{max})} - V_{\sin(\text{min})}}{V_{\cos(\text{max})} - V_{\cos(\text{min})}} \quad (20)$$

7.2 Typical Application

The TMAG6181-Q1 AMR angle sensor can be used in either in single-ended output mode or differential output mode. TMAG6181-Q1 has the drive capability to either drive differential-ended or single-ended SAR or Sigma Delta ADCs. Typically, an external microcontroller processes the AMR output signals to extract the angular position.

The differential-ended output mode is helpful to eliminate any common mode disturbances in the system. [Figure 7-2](#) shows a typical application circuit where the differential output signals SIN_P, SIN_N, COS_P, and COS_N are all connected to the four single-ended ADCs in the external microcontroller. If differential ADCs are available, then they are typically recommended. The load capacitors and resistors must match each other to typically achieve high accuracy. During sleep mode or when a fault is detected, the outputs are placed in high-impedance state. To ensure that external microcontroller can detect this case, TI recommends using pulldown or pullup resistors.

The TMAG6181-Q1 can drive capacitive loads up to 10nF directly on the AMR output pins and, for a cable with capacitances of 100pF/m, the device can drive up to 100m capacitive loads. With the ability to source and sink currents up to 1mA, the device can drive resistive loads.

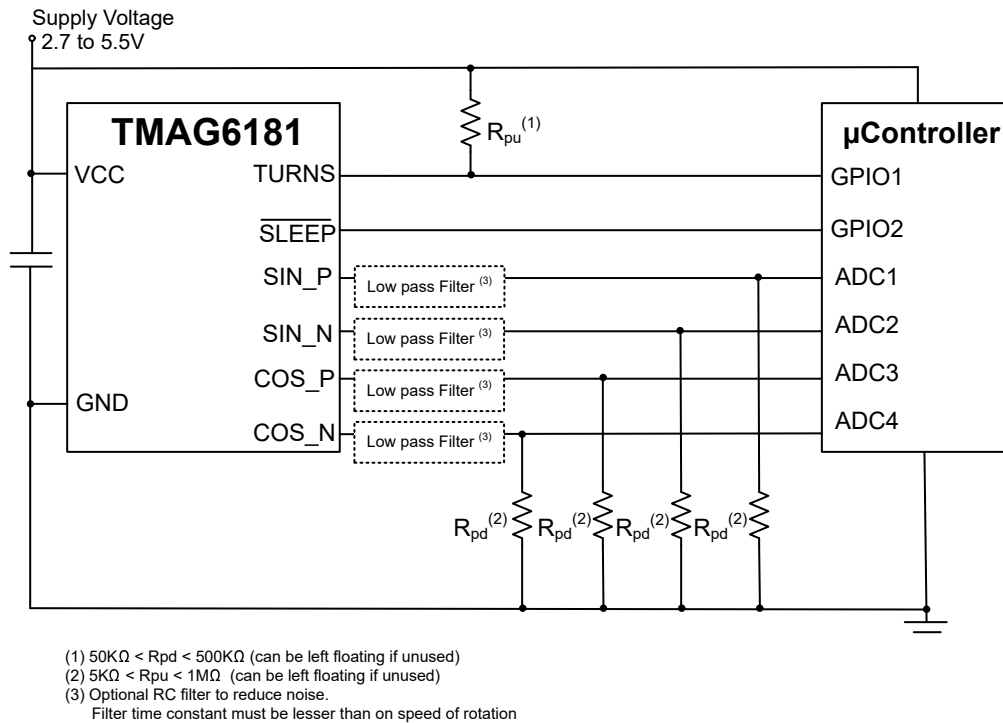
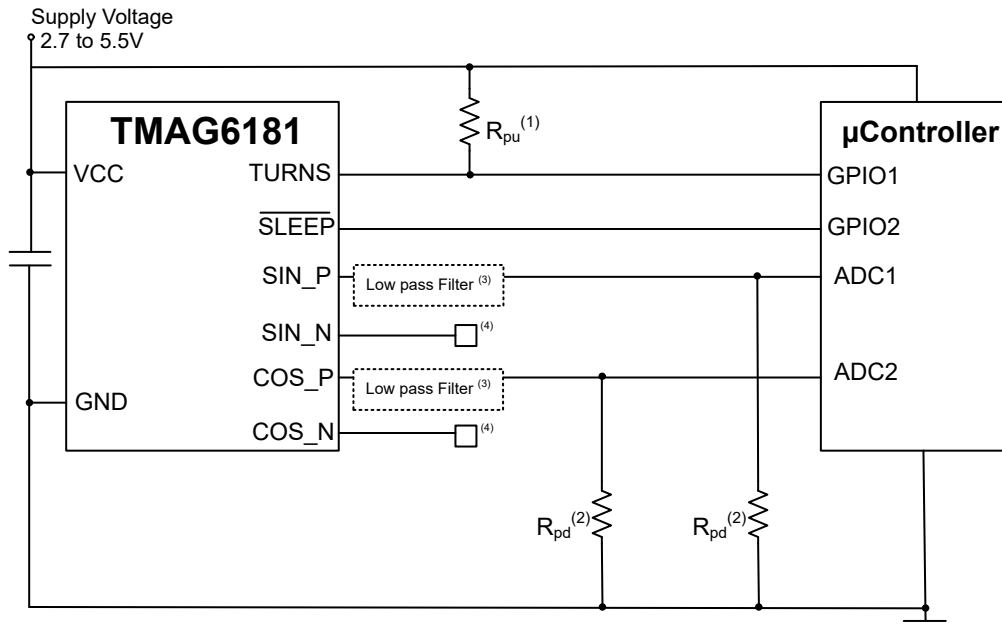

Figure 7-2. Application Diagram for TMAG6181-Q1 in Differential-Ended Output Mode

If the number of ADC ports in the microcontroller are limited, or if the number of wires from the sensor to the microcontroller must be kept to a minimum, [Figure 7-3](#) shows a typical application circuit where only the positive output channels (SIN_P and COS_P) are connected to single-ended ADCs. The unused output signals (SIN_N and COS_N) can be either left floating or connected to ground through a high resistance. In single-ended output mode, the dynamic range (SNR) and noise immunity is typically reduced compared to the differential output mode. To reduce noise on the outputs and for filtering EMC disturbances, an external low-pass filter such as a first order RC network can be used. The bandwidth of the external filter must be designed based on the rotation speed of the magnetic field to be detected. TI recommends adding pullup or pulldown resistors to ground on the single-ended outputs (SIN_P and COS_P) so the outputs are defined when the outputs are in high-impedance state. The supply voltage of the sensor is used as the reference for the ADCs in the microcontroller.



- (1) $50\text{K}\Omega < R_{pu} < 500\text{K}\Omega$ (can be left floating if unused)
- (2) $5\text{K}\Omega < R_{pd} < 1\text{M}\Omega$ (can be left floating if unused)
- (3) Optional RC filter to reduce noise.
Filter time constant must be lesser than on speed of rotation
- (4) Can be left floating or connected to ground through $R > 100\text{K}\Omega$

Figure 7-3. Application Diagram for TMAG6181-Q1 in Single-Ended Output Mode

7.2.1 Design Requirements

Figure 7-4 shows the center of the magnet aligned with the center of the sensor in a typical on-axis application.

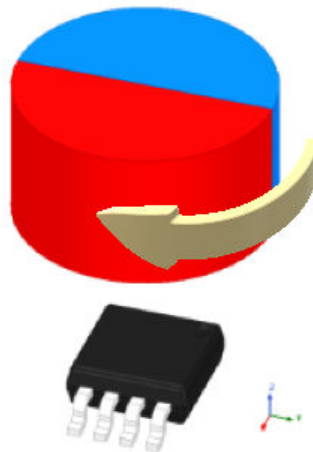

Figure 7-4. On-Axis Measurement Setup for TMAG6181-Q1

Use the parameters listed in [Table 7-1](#) for this design example.

Table 7-1. Design Parameters

DESIGN PARAMETERS	ON-AXIS MEASUREMENT
V_{CC}	5V
Magnet	Cylinder: 4.7625mm diameter, 12.7mm thick, neodymium N52, Br = 1480
Output mode	Differential-ended
Maximum speed of the motor	8,000rpm
Desired angle error across temperature	<1°
Magnet to sensor placement	End of shaft

7.2.2 Detailed Design Procedure

For accurate angle measurement, the center of the magnet is aligned to the center of the sensor with acceptable tolerances. Follow these steps to ensure that the sensor is calibrated for best accuracy:

- Reference angle calibration - Set the reference angle based on the magnet alignment to the sensor. This error can be saved in the microcontroller for runtime absolute position calculation. This error is also known as angle offset in a system.
- Electrical offset calibration - See [Calibration of Sensor Errors](#) for the offset calibration procedure. If the sensor cannot be rotated across the full range, then the electrical offsets cannot be calibrated.
- Amplitude mismatch calibration - See [Calibration of Sensor Errors](#) for the amplitude mismatch calibration procedure. If the sensor cannot be rotated across the full range, then the amplitude mismatch cannot be calibrated.

7.2.2.1 Designing with Multiple Sensors

Some applications have the need for multiple angle position sensors to either detect position in different parts of the system or for redundancy.

7.2.2.1.1 Designing for Redundancy

For applications that require the highest level of functional safety, two angle sensors can be required for redundancy purposes.

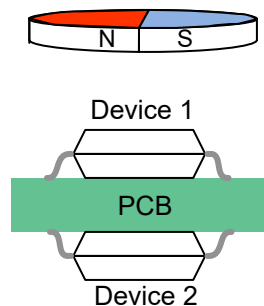

Figure 7-5. Two Sensors Placed on Either Side of the Board for Redundancy

To achieve redundancy without any impact on the angle accuracy, the TMAG6181-Q1 devices can be placed on either side of the PCB as shown in [Figure 7-5](#). The AMR sensors are sensitive to only the direction of the magnetic field and independent on the value of the absolute magnetic field, therefore the magnetic accuracy is not compromised even if the devices are placed on the other side of the PCB.

7.2.2.1.2 Multiplexing Multiple Sensors

Some applications require multiple angle position sensors to detect position in different parts of the system. In those cases, the primary challenge would be the availability of multiple ADC that are required to digitize the information from the sensors. In cases where the sensor is placed remotely away from the microcontroller, there can be multiple output lines between the sensor and microcontroller.

With the ability to place the output in high-impedance state during shutdown mode, multiple TMAG6181-Q1 devices can share the same analog output. This can minimize the system cost by using a single ADC per channel. Figure 7-6 shows two devices that share the same analog output, with their respective $\overline{\text{SLEEP}}$ pins controlled by the microcontroller. A pull-down resistor can be used to pull the output to ground when both the devices are placed in shutdown mode.

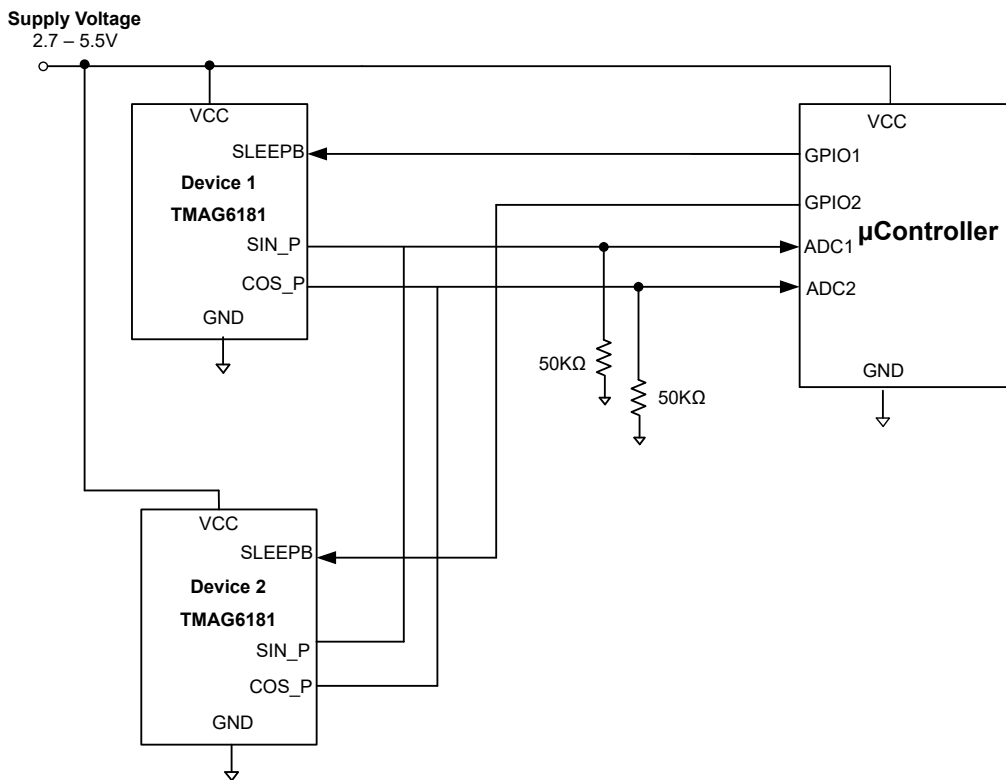

Figure 7-6. Multiple Sensors with Shared Output

Figure 7-7 shows how the GPIOs of the microcontroller can be used to multiplex the outputs from the two sensors. When the GPIO1 goes high, Device 1 is enabled and drives the output line to the corresponding output after the power-on time. During this time, GPIO2 is driven low and Device 2 is placed in shutdown mode. When the output from the second device must be measured, the first device must be turned off before the second device is enabled, indicated by t_{mux} in the timing diagram. B_1 and B_2 correspond to the magnetic fields seen by Device 1 and Device 2 respectively.

With the ability to support up to 10nF capacitive loads, the TMAG6181-Q1 can connect multiple sensors to the same output.

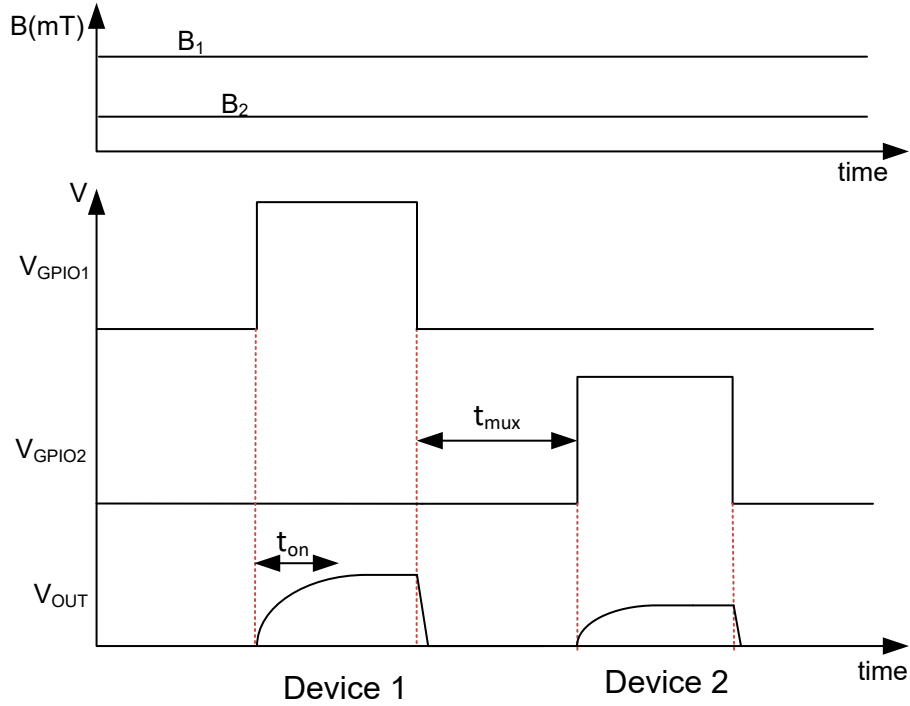

Figure 7-7. Timing Diagram for Multiplexing the Sensor Outputs

7.2.3 Application Curve

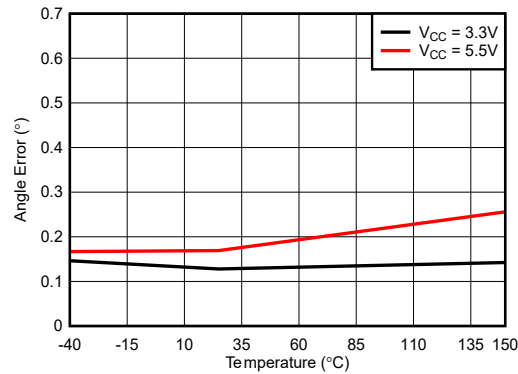

Figure 7-8. Angle Error with Dynamic Calibration

7.3 Power Supply Recommendations

A decoupling capacitor close to the device must be used to provide local energy with minimal inductance. TI recommends using a ceramic capacitor with a value of at least $0.01\mu\text{F}$.

7.4 Layout

7.4.1 Layout Guidelines

Magnetic fields pass through most nonferromagnetic materials with no significant disturbance. Embedding magnetic sensors within plastic or aluminum enclosures and sensing magnets on the outside is common practice. Magnetic fields also easily pass through most printed circuit boards (PCBs), which makes placing the magnet on the opposite side of the PCB possible.

7.4.2 Layout Example

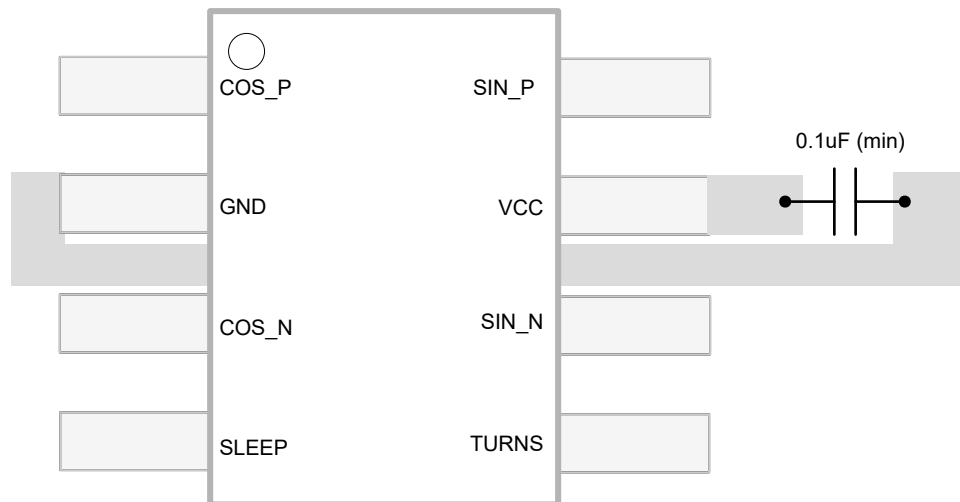

Figure 7-9. Layout Example With TMAG6181-Q1

8 Device and Documentation Support

8.1 Receiving Notification of Documentation Updates

To receive notification of documentation updates, navigate to the device product folder on [ti.com](https://www.ti.com). Click on *Notifications* to register and receive a weekly digest of any product information that has changed. For change details, review the revision history included in any revised document.

8.2 Support Resources

[TI E2E™ support forums](#) are an engineer's go-to source for fast, verified answers and design help — straight from the experts. Search existing answers or ask your own question to get the quick design help you need.

Linked content is provided "AS IS" by the respective contributors. They do not constitute TI specifications and do not necessarily reflect TI's views; see TI's [Terms of Use](#).

8.3 Trademarks

TI E2E™ is a trademark of Texas Instruments.
All trademarks are the property of their respective owners.

8.4 Electrostatic Discharge Caution



This integrated circuit can be damaged by ESD. Texas Instruments recommends that all integrated circuits be handled with appropriate precautions. Failure to observe proper handling and installation procedures can cause damage.

ESD damage can range from subtle performance degradation to complete device failure. Precision integrated circuits may be more susceptible to damage because very small parametric changes could cause the device not to meet its published specifications.

8.5 Glossary

[TI Glossary](#) This glossary lists and explains terms, acronyms, and definitions.

9 Revision History

Changes from Revision A (February 2024) to Revision B (August 2024)		Page
• Added $V_{\text{offset_room}}$ and $t_{\text{agc_update}}$ table notes to the <i>Electrical Characteristics</i> table.....		5
• Removed $V_{\text{CC_RAMP}}$ from the Electrical Characteristics table.....		5

Changes from Revision * (March 2023) to Revision A (February 2024)		Page
• Changed data sheet status from: Advanced Information to: Production Data.....		1

10 Mechanical, Packaging, and Orderable Information

The following pages include mechanical, packaging, and orderable information. This information is the most current data available for the designated devices. This data is subject to change without notice and revision of this document. For browser-based versions of this data sheet, refer to the left-hand navigation.

PACKAGING INFORMATION

Orderable part number	Status (1)	Material type (2)	Package Pins	Package qty Carrier	RoHS (3)	Lead finish/ Ball material (4)	MSL rating/ Peak reflow (5)	Op temp (°C)	Part marking (6)
TMAG6181EDGKRQ1	Active	Production	VSSOP (DGK) 8	2500 LARGE T&R	Yes	SN	Level-1-260C-UNLIM	-40 to 150	6181
TMAG6181EDGKRQ1.Z	Active	Production	VSSOP (DGK) 8	2500 LARGE T&R	Yes	SN	Level-1-260C-UNLIM	-40 to 150	6181

(1) **Status:** For more details on status, see our [product life cycle](#).

(2) **Material type:** When designated, preproduction parts are prototypes/experimental devices, and are not yet approved or released for full production. Testing and final process, including without limitation quality assurance, reliability performance testing, and/or process qualification, may not yet be complete, and this item is subject to further changes or possible discontinuation. If available for ordering, purchases will be subject to an additional waiver at checkout, and are intended for early internal evaluation purposes only. These items are sold without warranties of any kind.

(3) **RoHS values:** Yes, No, RoHS Exempt. See the [TI RoHS Statement](#) for additional information and value definition.

(4) **Lead finish/Ball material:** Parts may have multiple material finish options. Finish options are separated by a vertical ruled line. Lead finish/Ball material values may wrap to two lines if the finish value exceeds the maximum column width.

(5) **MSL rating/Peak reflow:** The moisture sensitivity level ratings and peak solder (reflow) temperatures. In the event that a part has multiple moisture sensitivity ratings, only the lowest level per JEDEC standards is shown. Refer to the shipping label for the actual reflow temperature that will be used to mount the part to the printed circuit board.

(6) **Part marking:** There may be an additional marking, which relates to the logo, the lot trace code information, or the environmental category of the part.

Multiple part markings will be inside parentheses. Only one part marking contained in parentheses and separated by a "~" will appear on a part. If a line is indented then it is a continuation of the previous line and the two combined represent the entire part marking for that device.

Important Information and Disclaimer: The information provided on this page represents TI's knowledge and belief as of the date that it is provided. TI bases its knowledge and belief on information provided by third parties, and makes no representation or warranty as to the accuracy of such information. Efforts are underway to better integrate information from third parties. TI has taken and continues to take reasonable steps to provide representative and accurate information but may not have conducted destructive testing or chemical analysis on incoming materials and chemicals. TI and TI suppliers consider certain information to be proprietary, and thus CAS numbers and other limited information may not be available for release.

In no event shall TI's liability arising out of such information exceed the total purchase price of the TI part(s) at issue in this document sold by TI to Customer on an annual basis.

TAPE AND REEL INFORMATION

QUADRANT ASSIGNMENTS FOR PIN 1 ORIENTATION IN TAPE

*All dimensions are nominal

Device	Package Type	Package Drawing	Pins	SPQ	Reel Diameter (mm)	Reel Width W1 (mm)	A0 (mm)	B0 (mm)	K0 (mm)	P1 (mm)	W (mm)	Pin1 Quadrant
TMAG6181EDGKRQ1	VSSOP	DGK	8	2500	330.0	12.4	5.25	3.35	1.25	8.0	12.0	Q1

TAPE AND REEL BOX DIMENSIONS

*All dimensions are nominal

Device	Package Type	Package Drawing	Pins	SPQ	Length (mm)	Width (mm)	Height (mm)
TMAG6181EDGKRQ1	VSSOP	DGK	8	2500	366.0	364.0	50.0

DGK0008A



PACKAGE OUTLINE

VSSOP - 1.1 mm max height

SMALL OUTLINE PACKAGE



NOTES:

PowerPAD is a trademark of Texas Instruments.

1. All linear dimensions are in millimeters. Any dimensions in parenthesis are for reference only. Dimensioning and tolerancing per ASME Y14.5M.
2. This drawing is subject to change without notice.
3. This dimension does not include mold flash, protrusions, or gate burrs. Mold flash, protrusions, or gate burrs shall not exceed 0.15 mm per side.
4. This dimension does not include interlead flash. Interlead flash shall not exceed 0.25 mm per side.
5. Reference JEDEC registration MO-187.

EXAMPLE BOARD LAYOUT

DGK0008A

™ VSSOP - 1.1 mm max height

SMALL OUTLINE PACKAGE



LAND PATTERN EXAMPLE
EXPOSED METAL SHOWN
SCALE: 15X



SOLDER MASK DETAILS

4214862/A 04/2023

NOTES: (continued)

6. Publication IPC-7351 may have alternate designs.
7. Solder mask tolerances between and around signal pads can vary based on board fabrication site.
8. Vias are optional depending on application, refer to device data sheet. If any vias are implemented, refer to their locations shown on this view. It is recommended that vias under paste be filled, plugged or tented.
9. Size of metal pad may vary due to creepage requirement.

EXAMPLE STENCIL DESIGN

DGK0008A

TM VSSOP - 1.1 mm max height

SMALL OUTLINE PACKAGE



SOLDER PASTE EXAMPLE
SCALE: 15X

4214862/A 04/2023

NOTES: (continued)

11. Laser cutting apertures with trapezoidal walls and rounded corners may offer better paste release. IPC-7525 may have alternate design recommendations.
12. Board assembly site may have different recommendations for stencil design.

IMPORTANT NOTICE AND DISCLAIMER

TI PROVIDES TECHNICAL AND RELIABILITY DATA (INCLUDING DATA SHEETS), DESIGN RESOURCES (INCLUDING REFERENCE DESIGNS), APPLICATION OR OTHER DESIGN ADVICE, WEB TOOLS, SAFETY INFORMATION, AND OTHER RESOURCES "AS IS" AND WITH ALL FAULTS, AND DISCLAIMS ALL WARRANTIES, EXPRESS AND IMPLIED, INCLUDING WITHOUT LIMITATION ANY IMPLIED WARRANTIES OF MERCHANTABILITY, FITNESS FOR A PARTICULAR PURPOSE OR NON-INFRINGEMENT OF THIRD PARTY INTELLECTUAL PROPERTY RIGHTS.

These resources are intended for skilled developers designing with TI products. You are solely responsible for (1) selecting the appropriate TI products for your application, (2) designing, validating and testing your application, and (3) ensuring your application meets applicable standards, and any other safety, security, regulatory or other requirements.

These resources are subject to change without notice. TI grants you permission to use these resources only for development of an application that uses the TI products described in the resource. Other reproduction and display of these resources is prohibited. No license is granted to any other TI intellectual property right or to any third party intellectual property right. TI disclaims responsibility for, and you will fully indemnify TI and its representatives against, any claims, damages, costs, losses, and liabilities arising out of your use of these resources.

TI's products are provided subject to [TI's Terms of Sale](#) or other applicable terms available either on [ti.com](https://www.ti.com) or provided in conjunction with such TI products. TI's provision of these resources does not expand or otherwise alter TI's applicable warranties or warranty disclaimers for TI products.

TI objects to and rejects any additional or different terms you may have proposed.

Mailing Address: Texas Instruments, Post Office Box 655303, Dallas, Texas 75265

Copyright © 2025, Texas Instruments Incorporated