

TPA2013D1 2.7-W Constant Output Power Class-D Audio Amplifier With Integrated Boost Converter

1 Features

- High Efficiency Integrated Boost Converter (Over 90% Efficiency)
- 2.2-W into an 8- Ω Load from a 3.6-V Supply
- 2.7-W into an 4- Ω Load from a 3.6-V Supply
- Operates from 1.8 V to 5.5 V
- Efficient Class-D Prolongs Battery Life
- Independent Shutdown for Boost Converter and Class-D Amplifier
- Differential Inputs Reduce RF Common Noise
- Built-In INPUT Low-Pass Filter Decreases RF and Out-of-Band Noise Sensitivity
- Synchronized Boost and Class-D Eliminates Beat Frequencies
- Thermal and Short-Circuit Protection
- Available in 2.275-mm \times 2.275-mm 16-ball WCSP and 4-mm \times 4-mm 20-Lead QFN Packages
- 3 Selectable Gain Settings of 2 V/V, 6 V/V, and 10 V/V

2 Applications

- Cell Phones
- PDA
- GPS
- Portable Electronics

3 Description

The TPA2013D1 device is a high efficiency Class-D audio power amplifier with an integrated boost converter. It drives up to 2.7 W (10% THD+N) into a 4- Ω speaker. With 85% typical efficiency, the TPA2013D1 helps extend battery life when playing audio.

The built-in boost converter generates the voltage rail for the Class-D amplifier. This provides a louder audio output than a stand-alone amplifier connected directly to the battery. It also maintains a consistent loudness, regardless of battery voltage. Additionally, the boost converter can be used to supply external devices.

The TPA2013D1 has an integrated low pass filter to improve RF rejection and reduce out-of-band noise, increasing the signal-to-noise ratio (SNR). A built-in PLL synchronizes the boost converter and Class-D switching frequencies, thus eliminating beat frequencies and improving audio quality. All outputs are fully protected against shorts to ground, power supply, and output-to-output shorts.

Device Information⁽¹⁾

PART NUMBER	PACKAGE	BODY SIZE (NOM)
TPA2013D1	VQFN (20)	4.00 mm \times 4.00 mm
	DSBGA (16)	2.275 mm \times 2.275 mm

(1) For all available packages, see the orderable addendum at the end of the data sheet.

Simplified Application Schematic

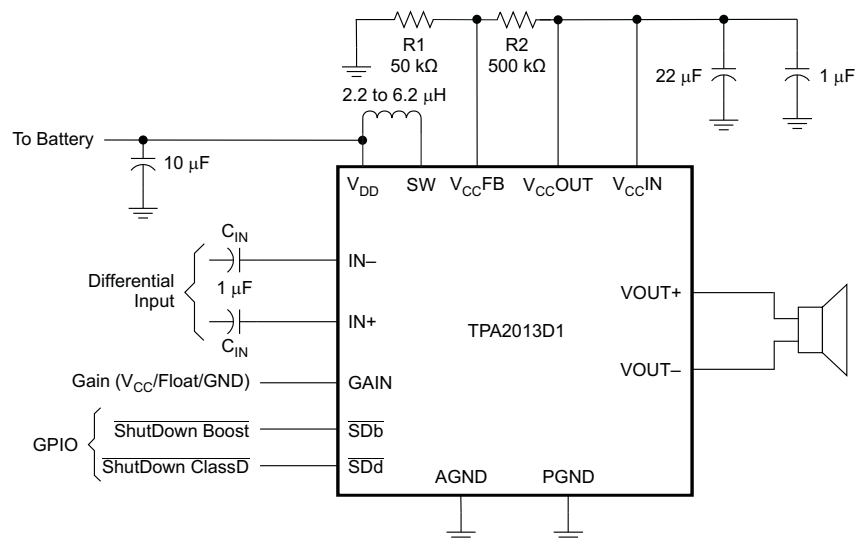

Table of Contents

1	Features	1	9.1	Overview	14
2	Applications	1	9.2	Functional Block Diagram	14
3	Description	1	9.3	Feature Description	14
4	Revision History	2	9.4	Device Functional Modes	16
5	Device Comparison Table	3	10	Application and Implementation	18
6	Pin Configuration and Functions	3	10.1	Application Information	18
7	Specifications	4	10.2	Typical Applications	18
7.1	Absolute Maximum Ratings	4	11	Power Supply Recommendations	25
7.2	ESD Ratings	4	11.1	Power Supply Decoupling Capacitors	25
7.3	Recommended Operating Conditions	4	12	Layout	25
7.4	Thermal Information	4	12.1	Layout Guidelines	25
7.5	DC Characteristics	5	12.2	Layout Examples	27
7.6	Boost Converter DC Characteristics	5	12.3	Efficiency and Thermal Considerations	28
7.7	Class D Amplifier DC Characteristics	6	13	Device and Documentation Support	30
7.8	AC Characteristics	6	13.1	Device Support	30
7.9	Class D Amplifier AC Characteristics	7	13.2	Community Resources	30
7.10	Dissipation Ratings	7	13.3	Trademarks	30
7.11	Typical Characteristics	8	13.4	Electrostatic Discharge Caution	30
8	Parameter Measurement Information	13	13.5	Glossary	30
9	Detailed Description	14	14	Mechanical, Packaging, and Orderable Information	31

4 Revision History

NOTE: Page numbers for previous revisions may differ from page numbers in the current version.

Changes from Original (August 2007) to Revision A

Page

- Added *ESD Ratings* table, *Feature Description* section, *Device Functional Modes*, *Application and Implementation* section, *Power Supply Recommendations* section, *Layout* section, *Device and Documentation Support* section, and *Mechanical, Packaging, and Orderable Information* section. **1**

5 Device Comparison Table

DEVICE NUMBER	SPEAKER AMP TYPE	SPECIAL FEATURE	OUTPUT POWER (W)	PSRR (Db)
TPA2013D1	Class D	Boost Converter	2.7	95
TPA2015D1	Class D	Adaptive Boost Converter	2	85
TPA2025D1	Class D	Class G Boost Converter	2	65
TPA2080D1	Class D	Class G Boost Converter	2.2	62.5

6 Pin Configuration and Functions

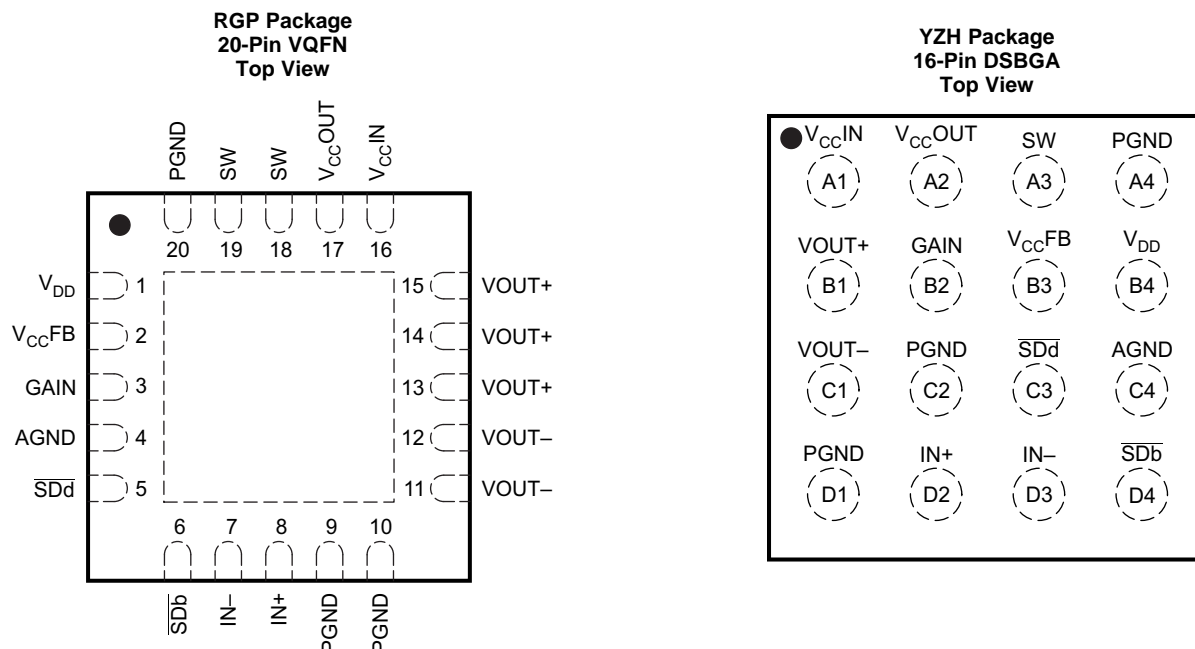

Pin Functions

NAME	PIN		I/O	DESCRIPTION
	VQFN	DSBGA		
AGND	4	C4	–	Analog ground – connect all GND pins together
GAIN	3	B2	I	Gain selection pin
IN+	8	D2	I	Positive audio input
IN–	7	D3	I	Negative audio input
PGND	9, 10, 20	D1, C2, A4	–	Power ground – connect all GND pins together
\overline{SDb}	6	D4	I	Shutdown terminal for the Boost Converter
\overline{SDd}	5	C3	I	Shutdown terminal for the Class D Amplifier
SW	18, 19	A3	–	Boost and rectifying switch input
Thermal Pad	Die Pad	N/A	P	Solder the thermal pad on the bottom of the QFN package to the GND plane of the PCB. It is required for mechanical stability and enhances thermal performance.
V_{CCFB}	2	B3	I	Voltage feedback
V_{CCIN}	16	A1	–	Class-D audio power amplifier voltage supply – connect to V_{CCOUT}
V_{CCOUT}	17	A2	–	Boost converter output – connect to V_{CCIN}
V_{DD}	1	B4	–	Supply voltage
VOUT+	13, 14, 15	B1	O	Positive audio output
VOUT–	11, 12	C1	O	Negative audio output

7 Specifications

7.1 Absolute Maximum Ratings

over operating free-air temperature range (unless otherwise noted)⁽¹⁾

		MIN	MAX	UNIT
V _{DD}	Supply voltage	-0.3	6	V
V _I	Input voltage, V _i : \overline{SDb} , \overline{SDd} , IN+, IN-, V _{CCFB}	-0.3	V _{DD} + 0.3	V
	Continuous total power dissipation	See Dissipation Ratings		
T _A	Operating free-air temperature	-40	85	°C
T _J	Operating junction temperature	-40	150	°C
T _{stg}	Storage temperature	-65	150	°C

- (1) Stresses beyond those listed under *Absolute Maximum Ratings* may cause permanent damage to the device. These are stress ratings only, which do not imply functional operation of the device at these or any other conditions beyond those indicated under *Recommended Operating Conditions*. Exposure to absolute-maximum-rated conditions for extended periods may affect device reliability.

7.2 ESD Ratings

			VALUE	UNIT
V _(ESD)	Electrostatic discharge	Human-body model (HBM), per ANSI/ESDA/JEDEC JS-001 ⁽¹⁾	±4000	V
		Charged-device model (CDM), per JEDEC specification JESD22-C101 ⁽²⁾	±1500	

- (1) JEDEC document JEP155 states that 500-V HBM allows safe manufacturing with a standard ESD control process.

- (2) JEDEC document JEP157 states that 250-V CDM allows safe manufacturing with a standard ESD control process.

7.3 Recommended Operating Conditions

			MIN	MAX	UNIT
V _{DD}	Supply voltage		1.8	5.5	V
V _{IH}	High-level input voltage	\overline{SDb} , \overline{SDd}	1.3		V
V _{IL}	Low-level input voltage	\overline{SDb} , \overline{SDd}		0.35	V
I _{IH}	High-level input current	$\overline{SDb} = \overline{SDd} = 5.8$ V, V _{DD} = 5.5 V, V _{CC} = 5.5 V		1	μA
I _{IL}	Low-level input current	$\overline{SDb} = \overline{SDd} = -0.3$ V, V _{DD} = 5.5 V, V _{CC} = 5.5 V		20	μA
T _A	Operating free-air temperature		-40	85	°C

7.4 Thermal Information

THERMAL METRIC ⁽¹⁾		TPA2013D1		UNIT
		RGP (VQFN)	YZH (DSBGA)	
		20 PINS	16 PINS	
R _{θJA}	Junction-to-ambient thermal resistance	34	70.6	°C/W
R _{θJC(top)}	Junction-to-case (top) thermal resistance	33.4	0.3	°C/W
R _{θJB}	Junction-to-board thermal resistance	10.5	15	°C/W
ψ _{JT}	Junction-to-top characterization parameter	0.4	1.8	°C/W
ψ _{JB}	Junction-to-board characterization parameter	10.5	14.2	°C/W
R _{θJC(bot)}	Junction-to-case (bottom) thermal resistance	3.1	—	°C/W

- (1) For more information about traditional and new thermal metrics, see the *Semiconductor and IC Package Thermal Metrics* application report, [SPRA953](#).

7.5 DC Characteristics

 $T_A = 25^\circ\text{C}$ (unless otherwise noted)

PARAMETER		TEST CONDITIONS	MIN	TYP	MAX	UNIT
V_{CC}	Class-D audio power amplifier voltage supply range, V_{CCIN}		3		5.5	V
I_{SD}	Shutdown quiescent current	$\overline{SDd} = \overline{SDb} = 0\text{ V}$, $V_{DD} = 1.8\text{ V}$, $R_L = 8\ \Omega$		0.04	1.5	μA
		$\overline{SDd} = \overline{SDb} = 0\text{ V}$, $V_{DD} = 3.6\text{ V}$, $R_L = 8\ \Omega$		0.04	1.5	
		$\overline{SDd} = \overline{SDb} = 0\text{ V}$, $V_{DD} = 4.5\text{ V}$, $R_L = 8\ \Omega$		0.02	1.5	
		$\overline{SDd} = \overline{SDb} = 0.35\text{ V}$, $V_{DD} = 1.8\text{ V}$, $R_L = 8\ \Omega$		0.03	1.5	
		$\overline{SDd} = \overline{SDb} = 0.35\text{ V}$, $V_{DD} = 3.6\text{ V}$, $R_L = 8\ \Omega$		0.03	1.5	
		$\overline{SDd} = \overline{SDb} = 0.35\text{ V}$, $V_{DD} = 4.5\text{ V}$, $R_L = 8\ \Omega$		0.02	1.5	
I_{DD}	Boost converter quiescent current	$\overline{SDd} = 0\text{ V}$, $\overline{SDb} = 1.3\text{ V}$, $V_{DD} = 3.6\text{ V}$, $V_{CC} = 5.5\text{ V}$, No Load, No Filter		1.3		mA
I_{CC}	Class D amplifier quiescent current	$V_{DD} = 3.6$, $V_{CC} = 5.5\text{ V}$, No Load, No Filter		4.3	6	mA
		$V_{DD} = 4.5$, $V_{CC} = 5.5\text{ V}$, No Load, No Filter		3.6	6	
I_{DD}	Boost converter and audio power amplifier quiescent current, Class D ⁽¹⁾	$\overline{SDd} = \overline{SDb} = 1.3\text{ V}$, $V_{DD} = 3.6\text{ V}$, $V_{CC} = 5.5\text{ V}$, No Load, No Filter		16.5	23	mA
		$\overline{SDd} = \overline{SDb} = 1.3\text{ V}$, $V_{DD} = 4.5\text{ V}$, $V_{CC} = 5.5\text{ V}$, No Load, No Filter		11	18.5	
f	Boost converter switching frequency		500	600	700	kHz
	Class D switching frequency		250	300	350	kHz
UVLO	Under voltage lockout				1.7	V
GAIN	Gain input low level	Gain = 2 V/V (6 dB)		0	0.35	V
	Gain input mid level	Gain = 6 V/V (15.5 dB) (floating input)	0.7	0.8	1	V
	Gain input high level	Gain = 10 V/V (20 dB)	1.35			V
POR_D	Class D Power on reset ON threshold			2.8		V

(1) I_{DD} is calculated using $I_{DD} = (I_{CC} \times V_{CC}) / (V_{DD} \times \eta)$, where I_{CC} is the class D amplifier quiescent current; $\eta = 40\%$, which is the boost converter efficiency when class D amplifier has no load. To achieve the minimal 40% η , it is recommended to use the suggested inductors in table 4 and to follow the layout guidelines.

7.6 Boost Converter DC Characteristics

 $T_A = 25^\circ\text{C}$ (unless otherwise noted)

PARAMETER		TEST CONDITIONS	MIN	TYP	MAX	UNIT
V_{CC}	Output voltage range		3		5.5	V
V_{FB}	Feedback voltage		490	500	510	mV
I_{OL}	Output current limit, Boost_max		1300	1500	1700	mA
R_{ON_PB}	PMOS switch resistance			220		m Ω
R_{ON_NB}	NMOS resistance			170		m Ω
	Line regulation	No Load, $1.8\text{ V} < V_{DD} < 5.2\text{ V}$, $V_{CC} = 5.5\text{ V}$		3		mV/V
	Load regulation	$V_{DD} = 3.6\text{ V}$, $0 < I_L < 500\text{ mA}$, $V_{CC} = 5.5\text{ V}$		30		mV/A
I_L	Start-up current limit, Boost			$0.4 \times I_{Boost}$		mA

7.7 Class D Amplifier DC Characteristics

 $T_A = 25^\circ\text{C}$ (unless otherwise noted)

PARAMETER		TEST CONDITIONS	MIN	TYP	MAX	UNIT
CMR	Input common mode range	$V_{in} = \pm 100\text{ mV}$, $V_{DD} = 1.8\text{ V}$, $V_{CC} = 3\text{ V}$, $R_L = 8\ \Omega$	0.5		2.2	V
		$V_{in} = \pm 100\text{ mV}$, $V_{DD} = 2.5\text{ V}$, $V_{CC} = 3.6\text{ V}$, $R_L = 8\ \Omega$	0.5		2.8	
		$V_{in} = \pm 100\text{ mV}$, $V_{DD} = 3.6\text{ V}$, $V_{CC} = 5.5\text{ V}$, $R_L = 8\ \Omega$	0.5		4.7	
CMRR	Input common mode rejection	$R_L = 8\ \Omega$, $V_{icm} = 0.5$ and $V_{icm} = V_{CC} - 0.8$, differential inputs shorted		-75		dB
V_{OO}	Output offset voltage Class-D	$V_{CC} = 3.6\text{ V}$, $A_v = 2\text{ V/V}$, $IN+ = IN- = V_{ref}$, $R_L = 8\ \Omega$		1	6	mV
		$V_{CC} = 3.6\text{ V}$, $A_v = 6\text{ V/V}$, $IN+ = IN- = V_{ref}$, $R_L = 8\ \Omega$		1	6	
		$V_{CC} = 3.6\text{ V}$, $A_v = 10\text{ V/V}$, $IN+ = IN- = V_{ref}$, $R_L = 8\ \Omega$		1	6	
		$V_{CC} = 5.5\text{ V}$, $A_v = 2\text{ V/V}$, $IN+ = IN- = V_{ref}$, $R_L = 8\ \Omega$		1	6	
R_{in}	Input Impedance	Gain = 2 V/V (6 dB)		32		k Ω
		Gain = 6 V/V (15.5 dB)		15		
		Gain = 10 V/V (20 dB)		9.5		
$R_{DS(on)}$	OUTP High-side FET On-state series resistance	$I_{OUTx} = -300\text{ mA}$; $V_{CC} = 3.6\text{ V}$		0.36		Ω
	OUTP Low-side FET On-state series resistance			0.36		
$R_{DS(on)}$	OUTN High-side FET On-state series resistance			0.36		
	OUTN Low-side FET On-state series resistance			0.36		
A_v	Low Gain	GAIN $\leq 0.35\text{ V}$	1.8	2	2.2	V/V
	Mid Gain	GAIN = 0.8 V	5.7	6	6.3	V/V
	High Gain	GAIN $\geq 1.35\text{ V}$	9.5	10	10.5	V/V

7.8 AC Characteristics

 $T_A = 25^\circ\text{C}$, $V_{DD} = 3.6\text{ V}$, $R_L = 8\ \Omega$, $L = 4.7\ \mu\text{H}$ (unless otherwise noted)

PARAMETER		TEST CONDITIONS	MIN	TYP	MAX	UNIT
t_{START}	Start up time	$1.8\text{ V} \leq V_{DD} \leq 5.5\text{ V}$, $C_{IN} \leq 1\ \mu\text{F}$		7.5		ms
η	Efficiency	THD+N = 1%, $V_{CC} = 5.5\text{ V}$, $V_{DD} = 3.6\text{ V}$, $R_L = 8\ \Omega$, $P_{out} = 1.7\text{ W}$, $C_{boost} = 47\ \mu\text{F}$		85%		
		THD+N = 1%, $V_{CC} = 5.5\text{ V}$, $V_{DD} = 4.2\text{ V}$, $R_L = 8\ \Omega$, $P_{out} = 1.7\text{ W}$		87.5%		
	Thermal Shutdown	Threshold		150		$^\circ\text{C}$

7.9 Class D Amplifier AC Characteristics

 $T_A = 25^\circ\text{C}$, $V_{DD} = 3.6\text{V}$, $R_L = 8\ \Omega$, $L = 4.7\ \mu\text{H}$ (unless otherwise noted)

PARAMETER		TEST CONDITIONS	MIN	TYP	MAX	UNIT
KSVR Class-D	Output referred power supply rejection ratio	$V_{DD} = 3.6\text{ V}$, $V_{CC} = 5.5\text{ V}$, 200 mV _{PP} ripple, $f = 217\text{ Hz}$		-95		dB
		$f = 1\text{ kHz}$, $P_o = 1.7\text{ W}$, $V_{CC} = 5.5\text{ V}$		1%		
THD+N Class-D	Total harmonic distortion + noise	$f = 1\text{ kHz}$, $P_o = 1.2\text{ W}$, $V_{CC} = 4.5\text{ V}$		1%		
		$f = 1\text{ kHz}$, $P_o = 2.2\text{ W}$, $V_{CC} = 5.5\text{ V}$		10%		
		$f = 1\text{ kHz}$, $P_o = 1\text{ W}$, $V_{CC} = 5.5\text{ V}$		0.1%		
V _n Class-D	Output integrated noise floor	$A_v = 6\text{ dB (2V/V)}$		31		μVrms
	Output integrated noise floor A-weighted	$A_v = 6\text{ dB (2V/V)}$		23		
P _o	Maximum output power	THD+N = 10%, $V_{CC} = 5.5\text{ V}$, $V_{DD} = 3.6\text{ V}$, $R_L = 8\ \Omega$		2.2		W
		THD+N = 1%, $V_{CC} = 5.5\text{ V}$, $V_{DD} = 3.6\text{ V}$, $R_L = 8\ \Omega$		1.7		
		THD+N = 1%, $V_{CC} = 4.5\text{ V}$, $V_{DD} = 3.6\text{ V}$, $R_L = 8\ \Omega$		1.2		
		THD+N = 10%, $V_{CC} = 5.5\text{ V}$, $V_{DD} = 3.6\text{ V}$, $R_L = 4\ \Omega$		2.7		
		THD+N = 1%, $V_{CC} = 5.5\text{ V}$, $V_{DD} = 3.6\text{ V}$, $R_L = 4\ \Omega$		2.2		
		THD+N = 1%, $V_{CC} = 4.5\text{ V}$, $V_{DD} = 3.6\text{ V}$, $R_L = 4\ \Omega$		1.9		

7.10 Dissipation Ratings

PACKAGE	$T_A \leq 25^\circ\text{C}$	DERATING FACTOR ⁽¹⁾	$T_A = 70^\circ\text{C}$	$T_A = 85^\circ\text{C}$
16 ball WCSP	1.5 W	12.4 mW/°C	1 W	0.8 W
20 pin QFN	2.5 W	20.1 mW/°C	1.6 W	1.3 W

(1) Derating factor measured with JEDEC High K board.

7.11 Typical Characteristics

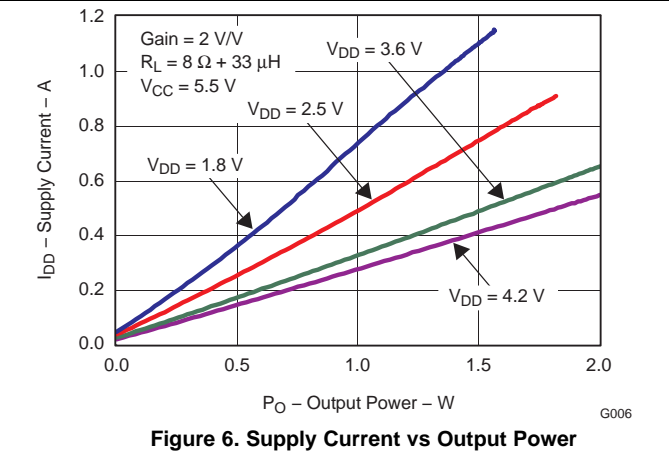
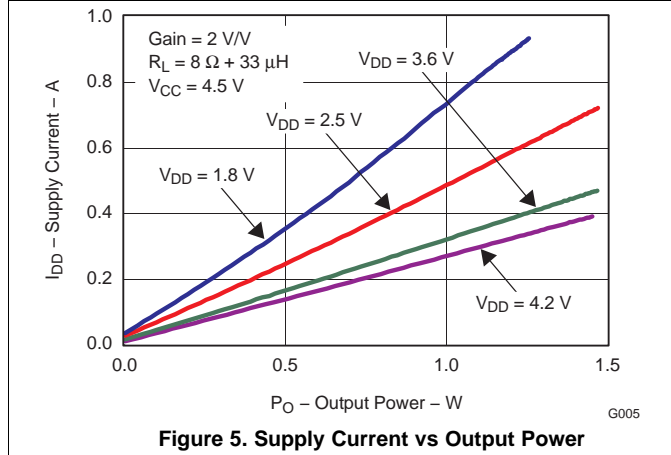
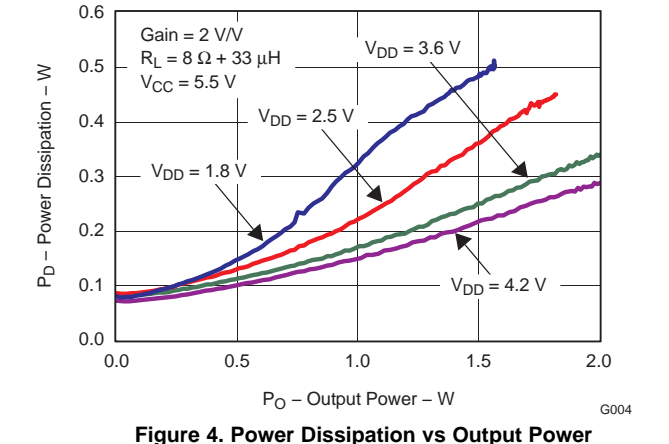
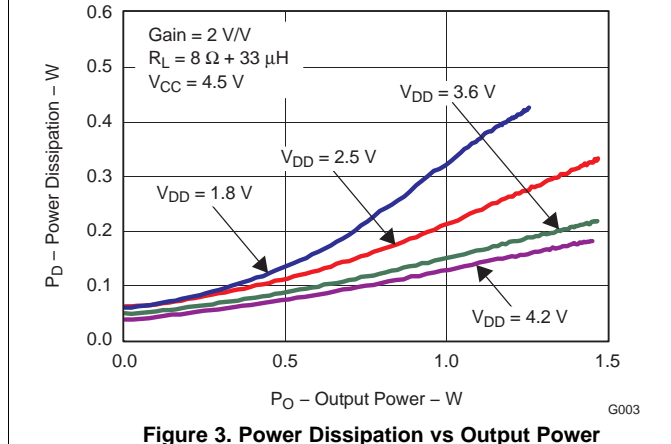
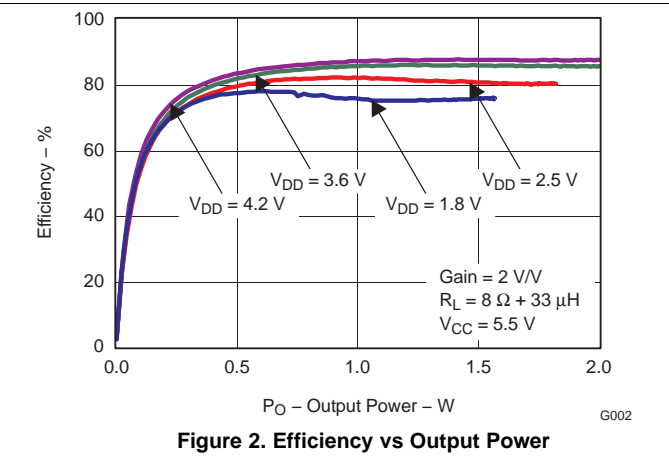
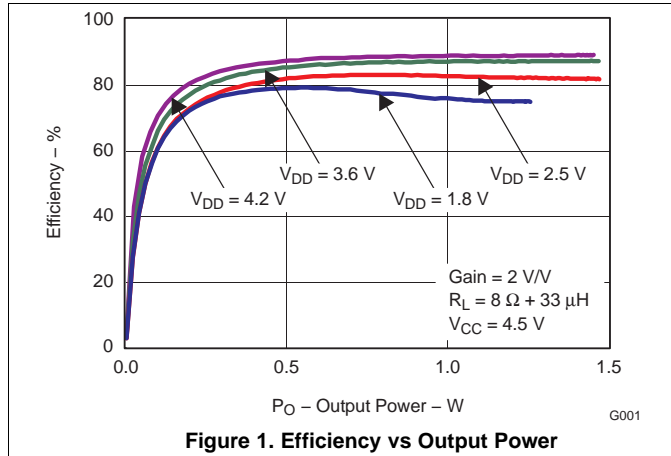

Typical Characteristics (continued)

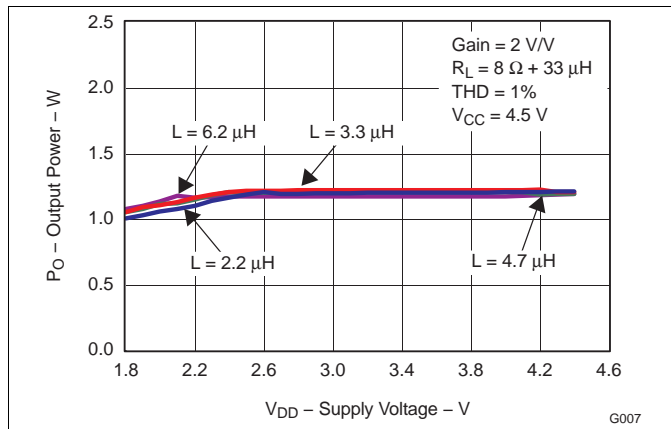

Figure 7. Output Power vs Supply Voltage

G007

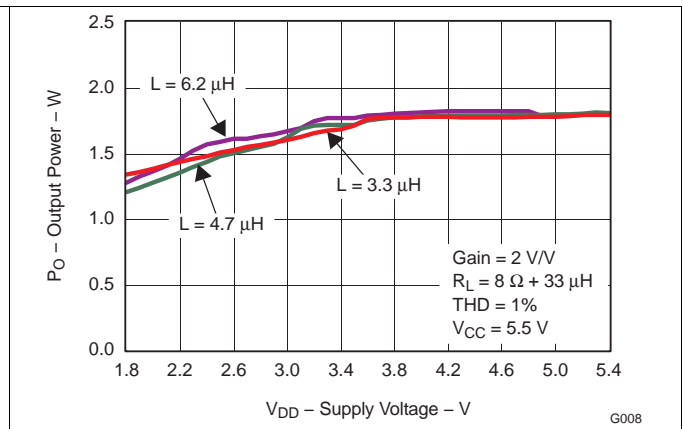

Figure 8. Output Power vs Supply Voltage

G008

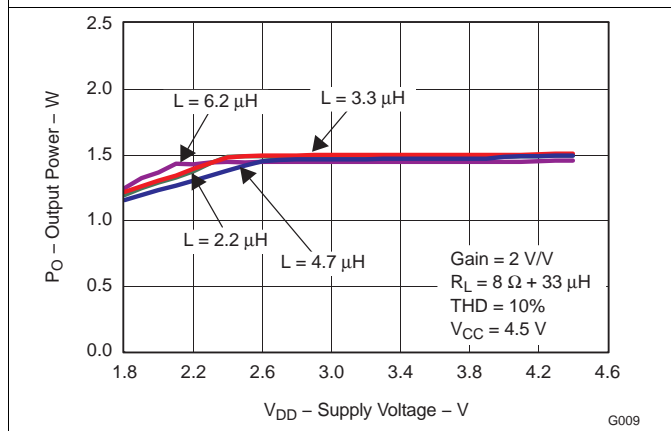

Figure 9. Output Power vs Supply Voltage

G009

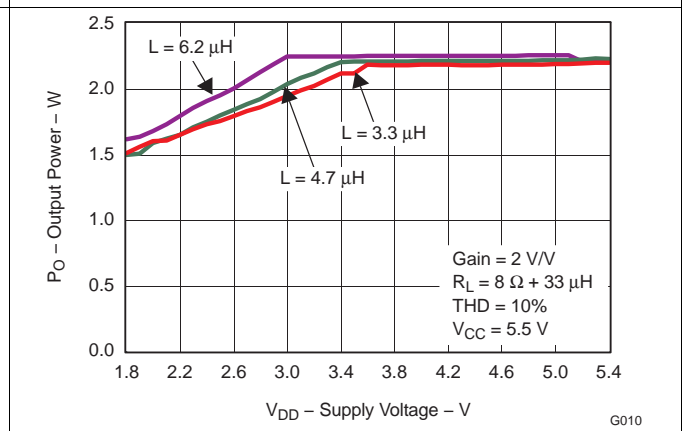

Figure 10. Output Power vs Supply Voltage

G010

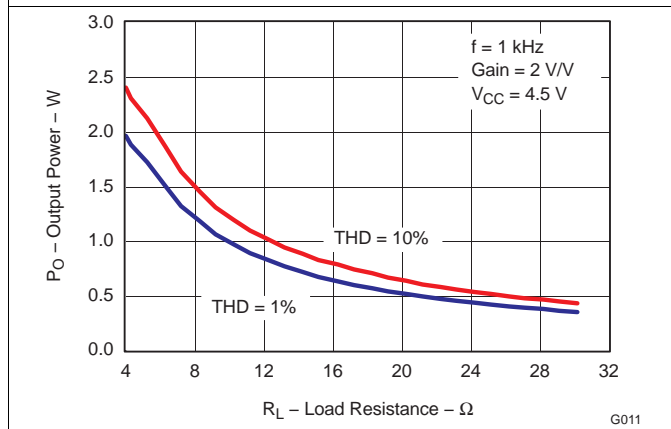

Figure 11. Output Power vs Load

G011

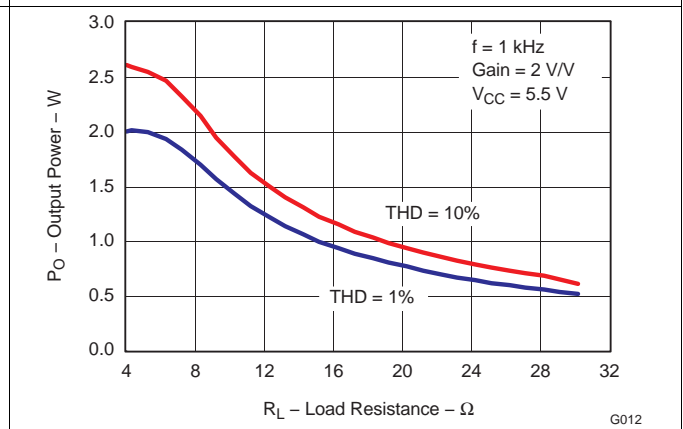
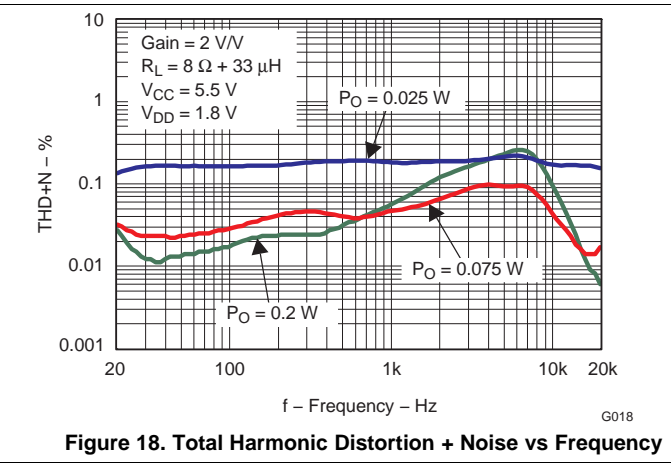
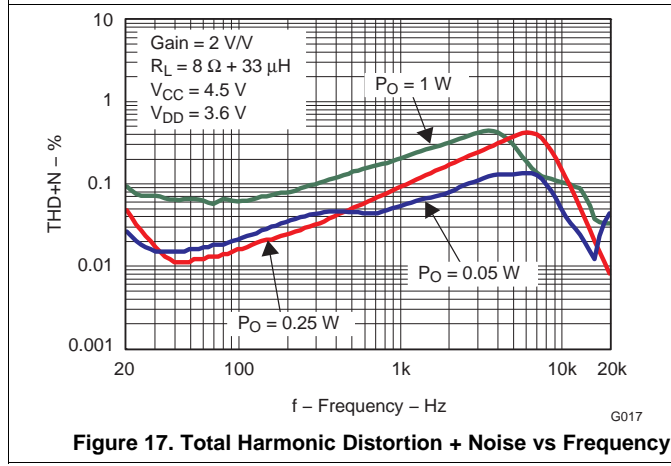
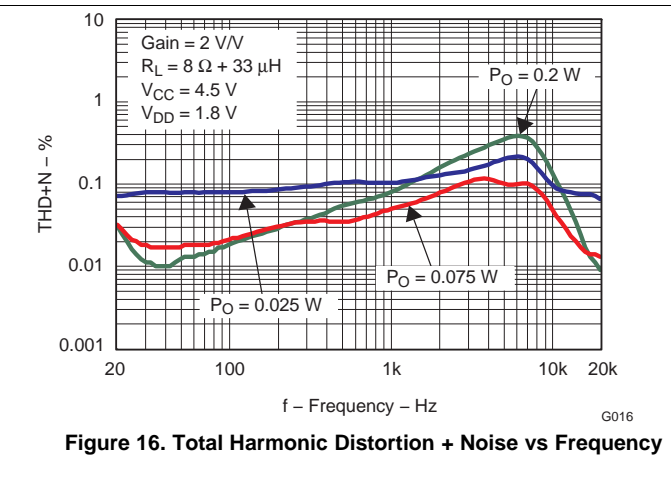
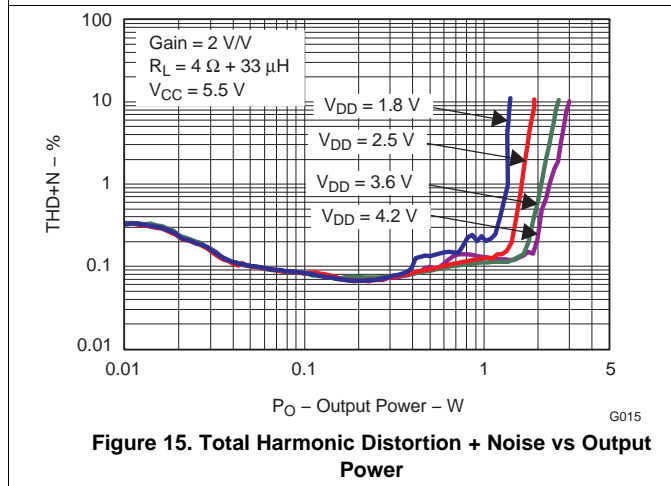
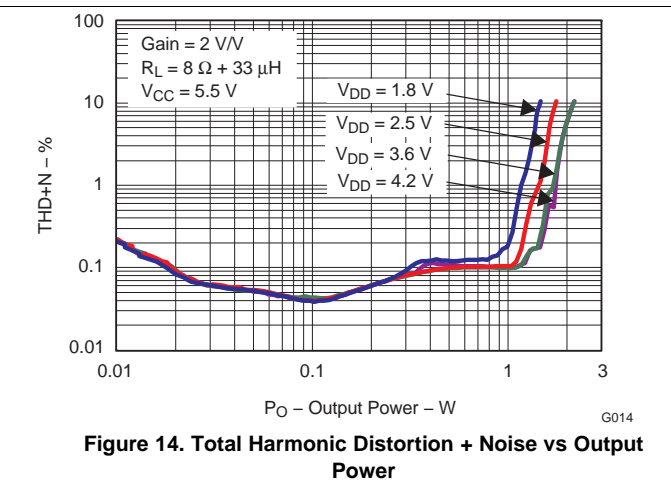
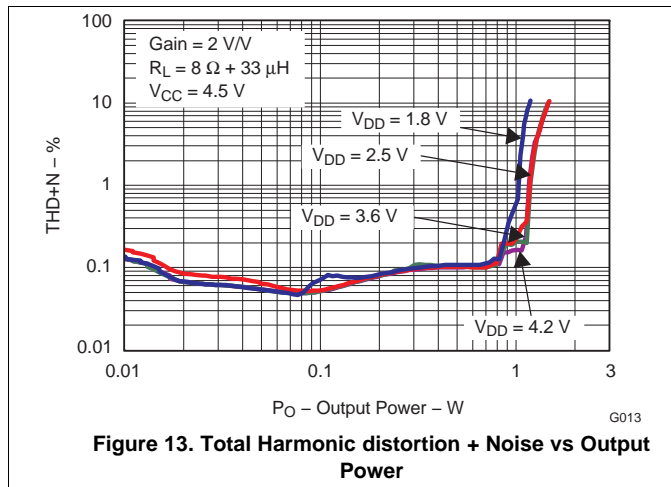

Figure 12. Output Power vs Load

G012

Typical Characteristics (continued)



Typical Characteristics (continued)

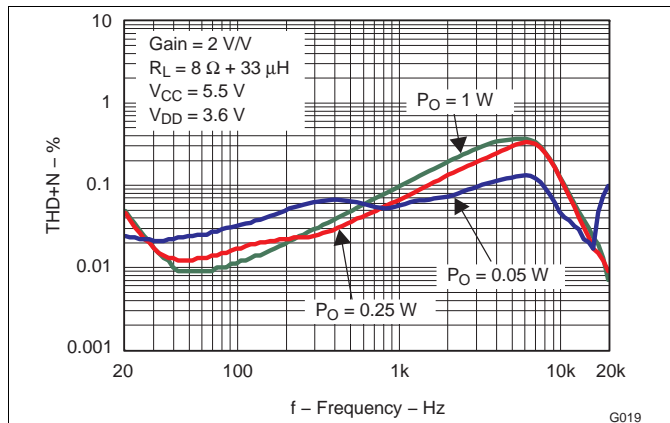

Figure 19. Total Harmonic Distortion + Noise vs Frequency

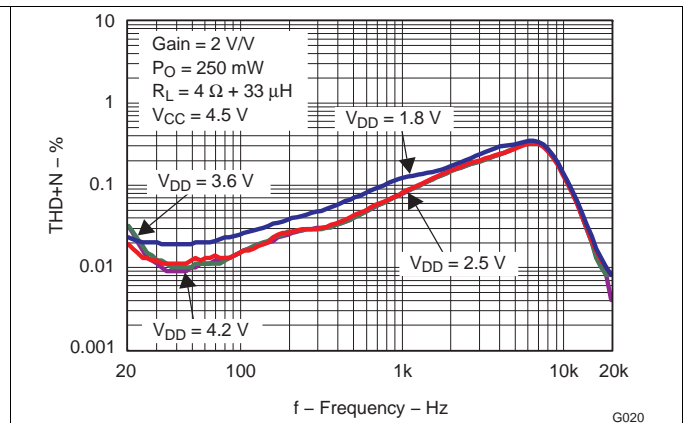

Figure 20. Total Harmonic Distortion + Noise vs Frequency

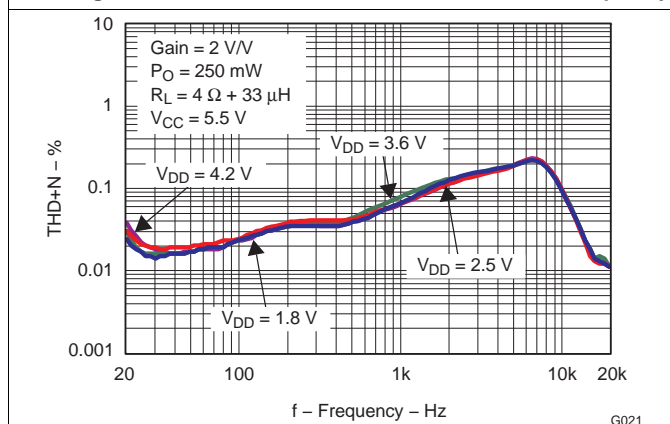

Figure 21. Total Harmonic Distortion + Noise vs Frequency

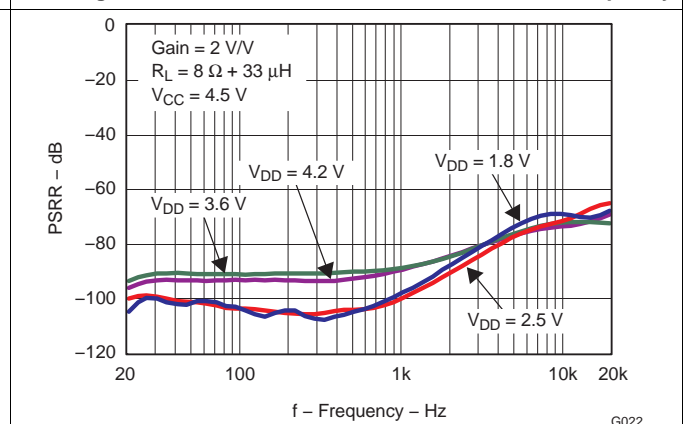

Figure 22. Power Supply Rejection Ratio vs Frequency

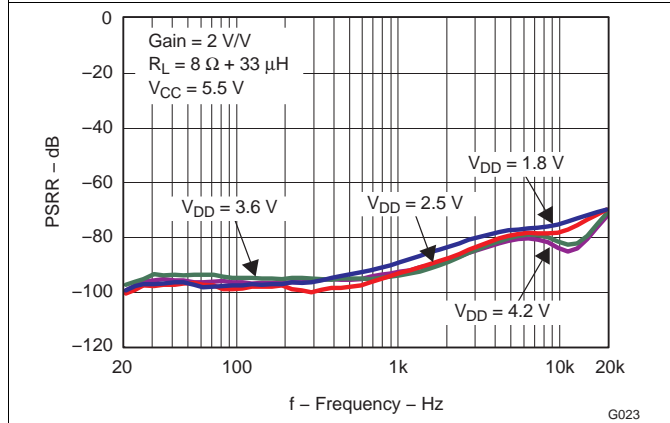

Figure 23. Power Supply Rejection Ratio vs Frequency

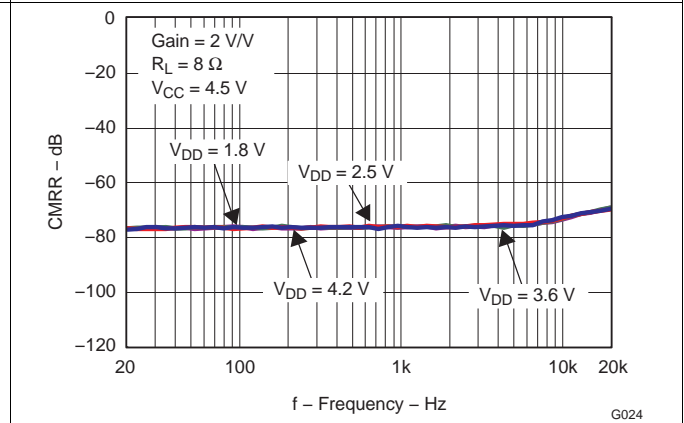

Figure 24. Common-Mode Rejection Ratio vs Frequency

Typical Characteristics (continued)

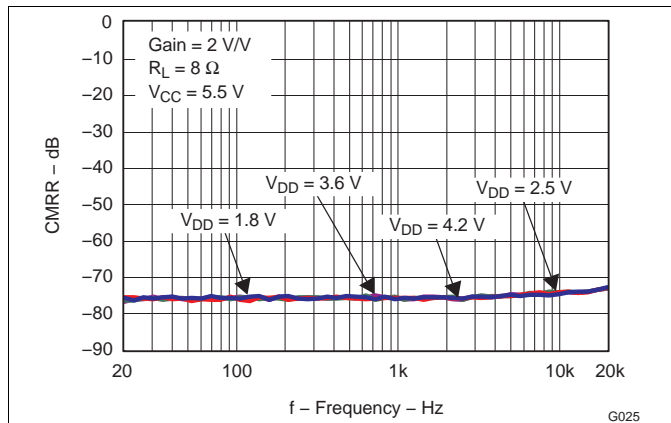

Figure 25. Common-Mode Rejection Ratio vs Frequency

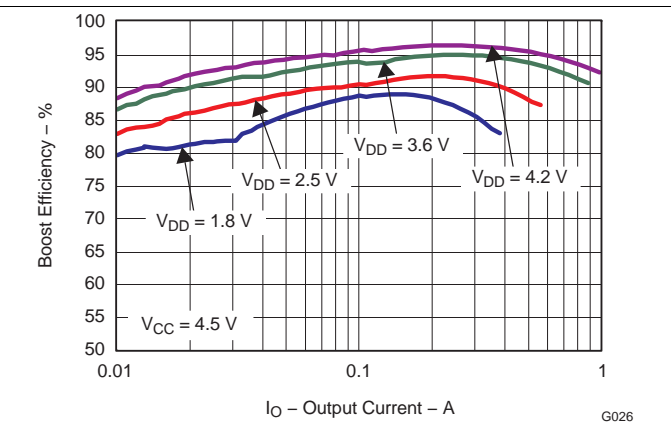

Figure 26. Boost Efficiency vs Output Current

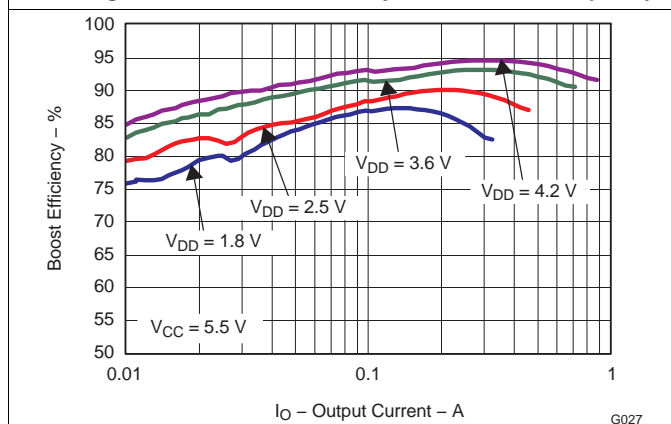

Figure 27. Boost Efficiency vs Output Current

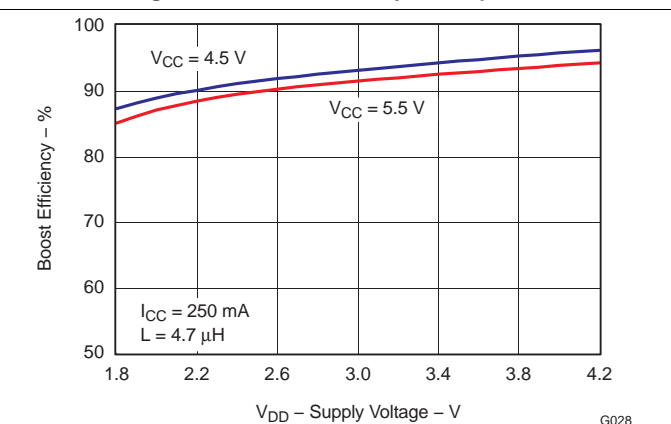

Figure 28. Boost Efficiency vs Supply Voltage

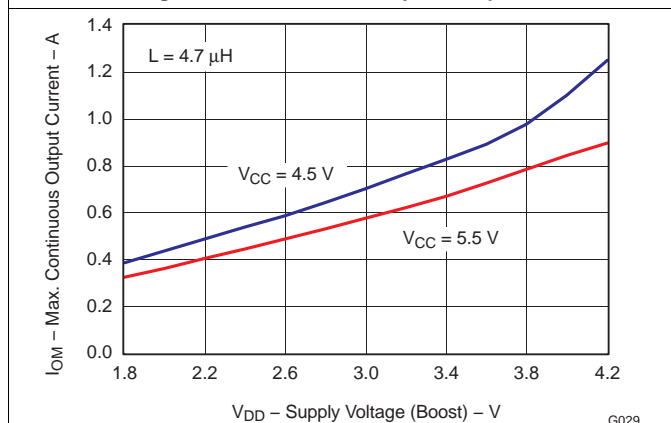

Figure 29. Maximum Continuous Output Current vs Supply Voltage (Boost)

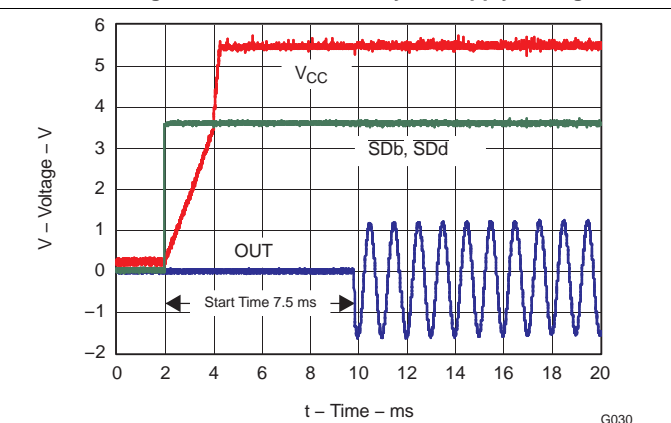
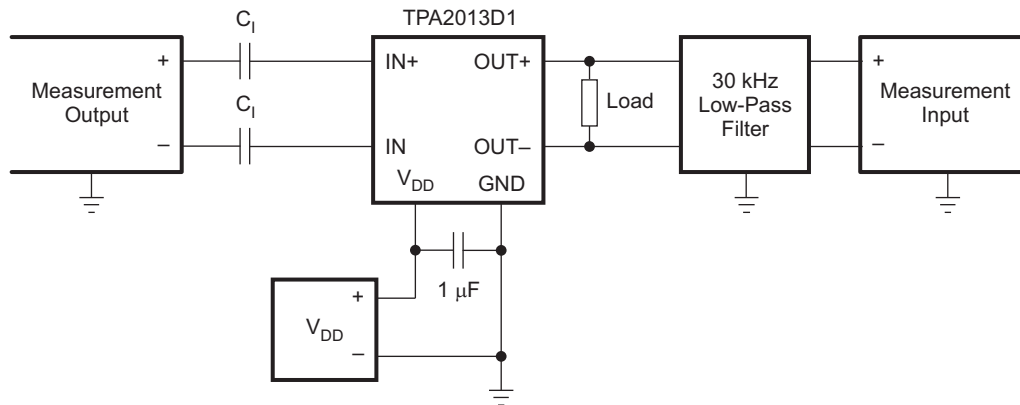

Figure 30. Start-Up Time

8 Parameter Measurement Information

All parameters are measured according to the conditions described in [Specifications](#). [Figure 31](#) shows the setup used for the typical characteristics of the test device.



- (1) C_1 was shorted for any common-mode input voltage measurement. All other measurements were taken with a $1\text{-}\mu\text{F}$ C_1 (unless otherwise noted).
- (2) A $33\text{-}\mu\text{H}$ inductor was placed in series with the load resistor to emulate a small speaker for efficiency measurements.
- (3) The 30-kHz low-pass filter is required, even if the analyzer has an internal low-pass filter. An RC low-pass filter ($100\text{-}\Omega$, 47-nF) is used on each output for the data sheet graphs.
- (4) $L = 4.7\text{ }\mu\text{H}$ is used for the boost converter unless otherwise noted.

Figure 31. Test Set-Up for Graphs

Feature Description (continued)

9.3.1.1 Advantages of Fully Differential Amplifiers

- Input-coupling capacitors not required:
 - The fully differential amplifier allows the inputs to be biased at voltage other than mid-supply. The inputs of the TPA2013D1 can be biased anywhere within the common mode input voltage range listed in the [Recommended Operating Conditions](#). If the inputs are biased outside of that range, input-coupling capacitors are required.
- Midsupply bypass capacitor, $C_{(BYPASS)}$, not required:
 - The fully differential amplifier does not require a bypass capacitor. Any shift in the midsupply affects both positive and negative channels equally and cancels at the differential output.
- Better RF-immunity:
 - GSM handsets save power by turning on and shutting off the RF transmitter at a rate of 217 Hz. The transmitted signal is picked-up on input and output traces. The fully differential amplifier cancels the signal better than the typical audio amplifier.

9.3.2 Class-D Amplifier

The TPA2013D1 is a high efficiency Class-D audio power amplifier with an integrated boost converter able to drive up to 2.7 W (10% THD+N) into a 4- Ω speaker with 85% typical efficiency, the device helps extend battery life when playing audio. It is available in 2.275-mm \times 2.275-mm 16-ball WCSP and 4-mm \times 4-mm 20-lead QFN packages. The device has three selectable gain settings of 2 V/V, 6 V/V and 10 V/V.

9.3.3 Boost Converter

The TPA2013D1 consists of a boost converter and a Class-D amplifier. The boost converter takes a low supply voltage, V_{DD} , and increases it to a higher output voltage, V_{CC} .

The two main passive components necessary for the boost converter are the boost inductor and the boost capacitor. The boost inductor stores current, and the boost capacitor stores charge. As the Class-D amplifier depletes the charge in the boost capacitor, the boost inductor charges it back up with the stored current. The cycle of charge and discharge occurs at a frequency of f_{boost} .

The TPA2013D1 allows a range of V_{CC} voltages, including setting V_{CC} lower than V_{DD} .

9.3.4 Operation With DACs and CODECs

When using switching amplifiers with CODECs and DACs, sometimes there is an increase in the output noise floor from the audio amplifier. This occurs when mixing of the output frequencies of the CODEC and DAC with the switching frequencies of the audio amplifier input stage. The noise increase can be solved by placing a low-pass filter between the CODEC and DAC and audio amplifier. This filters off the high frequencies that cause the problem and allow proper performance.

The TPA2013D1 has a two pole low-pass filter at the inputs. The cutoff frequency of the filter is set to approximately 100 kHz. The integrated low-pass filter of the TPA2013D1 eliminates the need for additional external filtering components. A properly designed additional low-pass filter may be added without altering the performance of the device.

If driving the TPA2013D1 input with 4th-order or higher $\Delta\Sigma$ DACs or CODECs, add an R-C low-pass filter at each of the audio inputs (IN+ and IN-) of the TPA2013D1 to ensure best performance. The recommended resistor value is 100 Ω and the capacitor value of 47 nF.

9.3.5 Filter-Free Operation and Ferrite Bead Filters

A ferrite bead filter can often be used if the design is failing radiated emissions without an LC filter and the frequency sensitive circuit is greater than 1 MHz. This filter functions well for circuits that just have to pass FCC and CE because FCC and CE only test radiated emissions greater than 30 MHz. When choosing a ferrite bead, choose one with high impedance at high frequencies, and very low impedance at low frequencies. In addition, select a ferrite bead with adequate current rating to prevent distortion of the output signal.

Use an LC output filter if there are low-frequency, (< 1 MHz) EMI-sensitive circuits and/or there are long leads from amplifier to speaker.

Feature Description (continued)

Figure 32 shows a typical ferrite bead output filters.

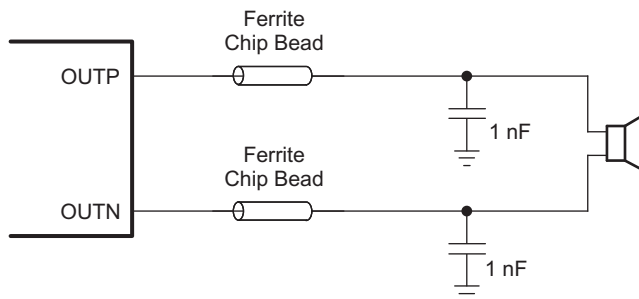

Figure 32. Typical Ferrite Chip Bead Filter

Table 1. Suggested Chip Ferrite Bead

LOAD	VENDOR	PART NUMBER	SIZE
8 Ω	Murata	BLM18EG121SN1	0603
4 Ω	TDK	MPZ2012S101A	0805

9.3.6 Fixed Gain Settings

The TPA2013D1 has 3 selectable fixed-gains: 6 dB, 15.5 dB, and 20 dB. Connect the GAIN pin as shown in Table 2.

Table 2. Amplifier Fixed-Gain

CONNECT GAIN PIN TO	AMPLIFIER GAIN
GND	6 dB
No connection (Floating)	15.5 dB
VBAT	20 dB

9.4 Device Functional Modes

9.4.1 Boost Converter Mode

The TPA2013D1 has 4 boost converter operation modes as shown in Table 3.

Table 3. Boost Converter Mode Condition

CASE	OUTPUT CURRENT	MODE OF OPERATION
$V_{DD} < V_{CC}$	Low	Continuous (fixed frequency)
$V_{DD} < V_{CC}$	High	Continuous (fixed frequency)
$V_{DD} \geq V_{CC}$	Low	Discontinuous (variable frequency)
$V_{DD} \geq V_{CC}$	High	Discontinuous (variable frequency)

9.4.2 Shutdown Mode

The TPA2013D1 amplifier can be put in shutdown mode when asserting SDD pin to a logic LOW. While in shutdown mode, the device output stage is turned off and the current consumption is very low. The boost converter can be put in shutdown mode when asserting SDB pin to a logic LOW. While in shutdown Mode, the boost converter is turned off.

Table 4. Device Configuration

$\overline{\text{SDb}}$	$\overline{\text{SDd}}$	BOOST CONVERTER	CLASS D AMPLIFIER	COMMENTS
low	low	OFF	OFF	Device is in shutdown mode $I_q \leq 1 \mu\text{A}$
low	high	OFF	ON	Boost converter is off. Class-D Audio Power Amplifier (APA) can be driven by an external pass transistor connected to the battery.
high	low	ON	OFF	Class-D APA is off. Boost Converter is on and can be used to drive an external device.
high	high	ON	ON	Boost converter and Class-D APA are on. Normal operation. Boost converter can be used to drive an external device in parallel to the Class-D APA within the limits of the boost converter output current.

10 Application and Implementation

NOTE

Information in the following applications sections is not part of the TI component specification, and TI does not warrant its accuracy or completeness. TI's customers are responsible for determining suitability of components for their purposes. Customers should validate and test their design implementation to confirm system functionality.

10.1 Application Information

These typical connection diagrams highlight the required external components and system level connections for proper operation of the device. Each of these configurations can be realized using the Evaluation Modules (EVMs) for the device. These flexible modules allow full evaluation of the device in the most common modes of operation. Any design variation can be supported by TI through schematic and layout reviews. Visit e2e.ti.com for design assistance, and join the audio amplifier discussion forum for additional information.

10.2 Typical Applications

10.2.1 TPA2013D1 With Differential Input Signal

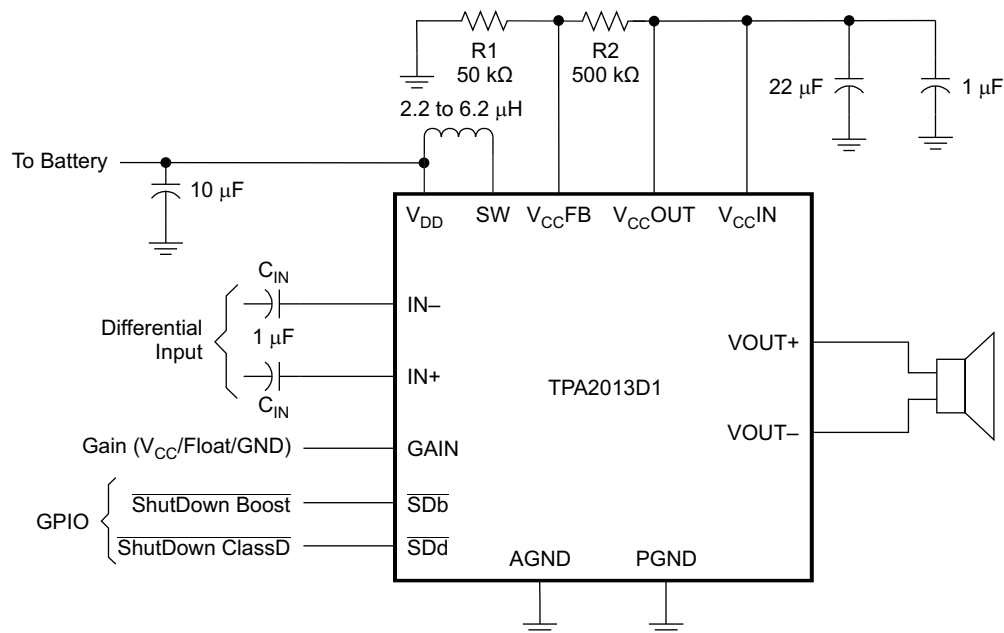

Figure 33. Typical Application Schematic With Differential Input Signals

10.2.1.1 Design Requirements

For this design example, use the parameters listed in [Table 5](#).

Table 5. Design Parameters

DESIGN PARAMETERS	EXAMPLE VALUE
Power Supply	3.6 V
Enable Inputs	High > 1.3 V
	Low < 0.6 V
Speaker	8 Ω

10.2.1.2 Detailed Design Procedure

10.2.1.2.1 Setting the Boost Voltage

Use [Equation 1](#) to determine the value of R1 for a given V_{CC} . The maximum recommended value for V_{CC} is 5.5 V. The typical value of the V_{CCFB} pin is 500 mV. The current through the resistor divider should be about 100 times greater than the current into the V_{CCFB} pin, typically 0.01 μ A. Based on those two values, the recommended value of R2 is 500 k Ω . V_{CC} must be greater than 3 V and less than or equal to 5.5 V.

$$V_{CC} = \left(\frac{0.5 \times (R1 + R2)}{R1} \right) \quad (1)$$

10.2.1.2.2 Inductor Selection

10.2.1.2.2.1 Surface Mount Inductors

Working inductance decreases as inductor current increases. If the drop in working inductance is severe enough, it may cause the boost converter to become unstable, or cause the TPA2013D1 to reach its current limit at a lower output power than expected. Inductor vendors specify currents at which inductor values decrease by a specific percentage. This can vary by 10% to 35%. Inductance is also affected by DC current and temperature.

10.2.1.2.2.2 TPA2013D1 Inductor Equations

Inductor current rating is determined by the requirements of the load. The inductance is determined by two factors: the minimum value required for stability and the maximum ripple current permitted in the application.

Use [Equation 2](#) to determine the required current rating. [Equation 2](#) shows the approximate relationship between the average inductor current, I_L , to the load current, load voltage, and input voltage (I_{CC} , V_{CC} , and V_{DD} , respectively). Insert I_{CC} , V_{CC} , and V_{DD} into [Equation 2](#) to solve for I_L . The inductor must maintain at least 90% of its initial inductance value at this current.

$$I_L = I_{CC} \times \left(\frac{V_{CC}}{V_{DD} \times 0.8} \right) \quad (2)$$

The minimum working inductance is 2.2 μ H. A lower value may cause instability.

Ripple current, ΔI_L , is peak-to-peak variation in inductor current. Smaller ripple current reduces core losses in the inductor as well as the potential for EMI. Use [Equation 3](#) to determine the value of the inductor, L. [Equation 3](#) shows the relationship between inductance L, V_{DD} , V_{CC} , the switching frequency, f_{boost} , and ΔI_L . Insert the maximum acceptable ripple current into [Equation 3](#) to solve for L.

$$L = \frac{V_{DD} \times (V_{CC} - V_{DD})}{\Delta I_L \times f_{boost} \times V_{CC}} \quad (3)$$

ΔI_L is inversely proportional to L. Minimize ΔI_L as much as is necessary for a specific application. Increase the inductance to reduce the ripple current.

NOTE

Making the inductance too large prevents the boost converter from responding to fast load changes properly. Typical inductor values for the TPA2013D1 are 4.7 μ H to 6.8 μ H.

Select an inductor with a small DC resistance, DCR. DCR reduces the output power due to the voltage drop across the inductor.

10.2.1.2.3 Capacitor Selection

10.2.1.2.3.1 Surface Mount Capacitors

Temperature and applied DC voltage influence the actual capacitance of high-K materials.

[Table 6](#) shows the relationship between the different types of high-K materials and their associated tolerances, temperature coefficients, and temperature ranges. Notice that a capacitor made with X5R material can lose up to 15% of its capacitance within its working temperature range.

High-K material is very sensitive to applied DC voltage. X5R capacitors can have losses ranging from 15 to 45% of their initial capacitance with only half of their DC-rated voltage applied. For example, if 5 Vdc is applied to a 10-V, 1-μF X5R capacitor, the measured capacitance at that point may show 0.85 μF, 0.55 μF, or somewhere in between. Y5V capacitors have losses that can reach or exceed 50% to 75% of their rated value.

In an application, the working capacitance of components made with high-K materials is generally much lower than nominal capacitance. A worst-case result with a typical X5R material might be –10% tolerance, –15% temperature effect, and –45% DC-voltage effect at 50% of the rated voltage. This particular case would result in a working capacitance of 42% ($0.9 \times 0.85 \times 0.55$) of the nominal value.

Select high-K ceramic capacitors according to the following rules:

1. Use capacitors made of materials with temperature coefficients of X5R, X7R, or better.
2. Use capacitors with DC-voltage ratings of at least twice the application voltage. Use minimum 10-V capacitors for the TPA2013D1.
3. Choose a capacitance value at least twice the nominal value calculated for the application. Multiply the nominal value by a factor of 2 for safety. If a 10-μF capacitor is required, use 20 μF.

The preceding rules and recommendations apply to capacitors used in connection with the TPA2013D1. The TPA2013D1 cannot meet its performance specifications if the rules and recommendations are not followed.

Table 6. Typical Tolerance and Temperature Coefficient of Capacitance by Material

MATERIAL	COG/NPO	X7R	X5R
Typical Tolerance	±5%	±10%	80/–20%
Temperature Coefficient	±30ppm	±15%	22/–82%
Temperature Range, °C	–55/125°C	–55/125°C	–30/85°C

10.2.1.2.3.2 TPA2013D1 Capacitor Equations

The value of the boost capacitor is determined by the minimum value of working capacitance required for stability and the maximum voltage ripple allowed on V_{CC} in the application. The minimum value of working capacitance is 10 μF. Do not use any component with a working capacitance less than 10 μF.

For X5R or X7R ceramic capacitors, Equation 4 shows the relationship between the boost capacitance, C, to load current, load voltage, ripple voltage, input voltage, and switching frequency (I_{CC} , V_{CC} , ΔV , V_{DD} , f_{boost} respectively). Insert the maximum allowed ripple voltage into Equation 4 to solve for C. A factor of 2 is included to implement the rules and specifications listed earlier.

$$C = 2 \times \frac{I_{CC} \times (V_{CC} - V_{DD})}{\Delta V \times f_{boost} \times V_{CC}} \quad (4)$$

For aluminum or tantalum capacitors, Equation 5 shows the relationship between the boost capacitance, C, to load current, load voltage, ripple voltage, input voltage, and switching frequency (I_{CC} , V_{CC} , ΔV , V_{DD} , f_{boost} respectively). Insert the maximum allowed ripple voltage into Equation 5 to solve for C. Solve this equation assuming ESR is zero.

$$C = \frac{I_{CC} \times (V_{CC} - V_{DD})}{\Delta V \times f_{boost} \times V_{CC}} \quad (5)$$

Capacitance of aluminum and tantalum capacitors is normally not sensitive to applied voltage, so there is no factor of 2 included in Equation 5. However, the ESR in aluminum and tantalum capacitors can be significant. Choose an aluminum or tantalum capacitor with ESR around 30 mΩ. For best performance using of tantalum capacitor, use at least a 10-V rating.

NOTE

Tantalum capacitors must generally be used at voltages of half their ratings or less.

10.2.1.2.4 Recommended Inductor and Capacitor Values by Application

Use Table 7 as a guide for determining the proper inductor and capacitor values.

Table 7. Recommended Values

CLASS-D OUTPUT POWER (W) ⁽¹⁾	CLASS-D LOAD (Ω)	MINIMUM V _{DD} (V)	REQUIRED V _{CC} (V)	MAX I _L (A)	L (μH)	INDUCTOR VENDOR PART NUMBERS	MAX ΔV (mVpp)	C ⁽²⁾ (μF)	CAPACITOR VENDOR PART NUMBERS
1	8	3	4.3	0.70	3.3	Toko DE2812C Coilcraft DO3314 Murata LQH3NPN3R3NG0	30	10	Kemet C1206C106K8PACTU Murata GRM32ER61A106KA01B Taiyo Yuden LMK316BJ106ML-T
					4.7			22	
1.6	8	3	5.5	1.13	4.7	Murata LQH32PN4R7NN0 Toko DE4514C Coilcraft LPS4018-472	30	22	Murata GRM32ER71A226KE20L Taiyo Yuden LMK316BJ226ML-T
					3.3			33	
2	4	3	4.6	1.53	3.3	Murata LQH55PN3R3NR0 Toko DE4514C	30	33	TDK C4532X5R1A336M
					6.2			47	
2.3	4	1.8	5.5	2	6.2	Sumida CDRH5D28NP-6R2NC	30	47	Murata GRM32ER61A476KE20L Taiyo Yuden LMK325BJ476MM-T

(1) All power levels are calculated at 1% THD unless otherwise noted

(2) All values listed are for ceramic capacitors. The correction factor of 2 is included in the values.

10.2.1.2.5 Components Location and Selection

10.2.1.2.5.1 Decoupling Capacitors

The TPA2013D1 is a high-performance Class-D audio amplifier that requires adequate power-supply decoupling to ensure the efficiency is high and total harmonic distortion (THD) is low. Place a low equivalent-series-resistance (ESR) ceramic capacitor, typically 1 μF, as close as possible to the device VDD lead. This choice of capacitor and placement helps with higher frequency transients, spikes, or digital hash on the line. Additionally, placing this decoupling capacitor close to the TPA2013D1 is important for the efficiency of the Class-D amplifier, because any resistance or inductance in the trace between the device and the capacitor can cause a loss in efficiency. Place a capacitor of 10 μF or greater between the power supply and the boost inductor. The capacitor filters out high-frequency noise. More importantly, it acts as a charge reservoir, providing energy more quickly than the board supply, thus helping to prevent any droop.

10.2.1.2.5.2 Input Capacitors

The TPA2013D1 does not require input coupling capacitors if the design uses a differential source that is biased within the common mode input range. Use input coupling capacitors if the input signal is not biased within the recommended common-mode input range, if high-pass filtering is needed, or if using a single-ended source.

The input capacitors and input resistors form a high-pass filter with the corner frequency, f_c , determined in Equation 6.

$$f_c = \frac{1}{(2 \times \pi \times R_I C_I)} \quad (6)$$

The value of the input capacitor is important to consider as it directly affects the bass (low frequency) performance of the circuit. Speakers in wireless phones cannot usually respond well to low frequencies, so the corner frequency can be set to block low frequencies in this application. Not using input capacitors can increase output offset.

Use Equation 7 to find the required the input coupling capacitance.

$$C_I = \frac{1}{(2 \times \pi \times f_c \times R_I)} \quad (7)$$

Any mismatch in capacitance between the two inputs causes a mismatch in the corner frequencies. Choose capacitors with a tolerance of ±10% or better.

10.2.1.3 Application Curves

For application curves, see the figures listed in table Table 8.

Table 8. Table of Graphs

DESCRIPTION	FIGURE NUMBER
Efficiency vs Output Power	Figure 1
Supply Current vs Output Power	Figure 5
Output Power vs Supply Voltage	Figure 7
Output Power vs Load	Figure 11

10.2.2 Bypassing the Boost Converter

Bypass the boost converter to drive the Class-D amplifier directly from the battery. Place a Schottky diode between the SW pin and the V_{CC}IN pin. Select a diode that has an average forward current rating of at least 1 A, reverse breakdown voltage of 10 V or greater, and a forward voltage as small as possible. See [Figure 34](#) for an example of a circuit designed to bypass the boost converter.

Do not configure the circuit to bypass the boost converter if V_{DD} is higher than V_{CC} when the boost converter is enabled (SDB ≥ 1.3 V); V_{DD} must be lower than V_{CC} for proper operation. V_{DD} may be set to any voltage within the recommended operating range when the boost converter is disabled (SDB ≤ 0.3 V).

Place a logic high on SDB to place the TPA2013D1 in boost mode. Place a logic low on SDB to place the TPA2013D1 in bypass mode.

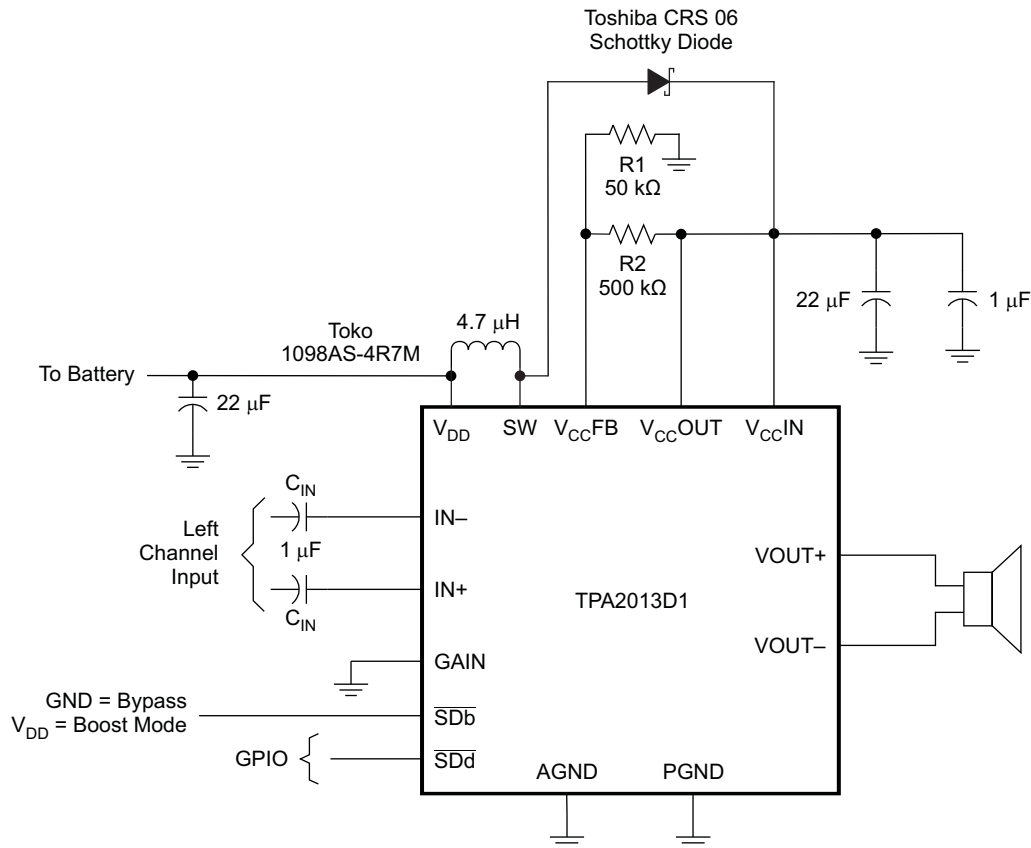

Figure 34. Bypass Circuit

10.2.2.1 Design Requirements

For this design example, use the parameters listed in [Table 5](#).

10.2.2.2 Detailed Design Procedure

For the design procedure, see [Detailed Design Procedure](#).

10.2.2.3 Application Curves

For application curves, see the figures listed in [Table 8](#).

10.2.3 Stereo Operation Application

Use the boost converter of the TPA2013D1 to supply the power for another audio amplifier when stereo operation is required. Ensure the gains of the amplifiers match each other. This prevents one channel from sounding louder than the other. Use [Equation 1](#) through [Equation 5](#) to determine R1, R2, boost inductor, and the boost capacitor values. [Figure 35](#) is an example schematic. The TPA2032D1 is a good choice for this application; the gain is internally set to 2 V/V, the power supply is compatible with V_{CC}OUT of the TPA2013D1, and the output power of the TPA2032D1 is on par with the TPA2013D1.

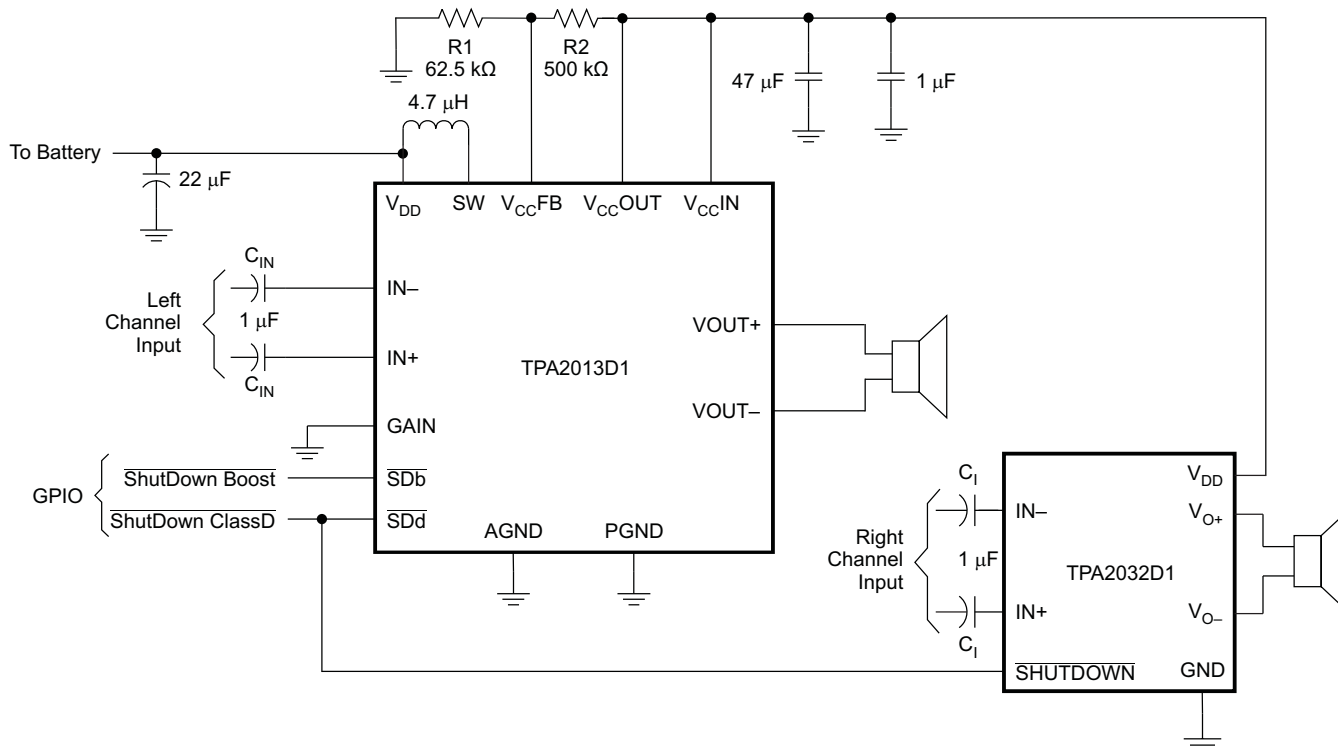

Figure 35. TPA2013D1 in Stereo With the TPA2032D1

10.2.3.1 Design Requirements

For this design example, use the parameters listed in [Table 5](#).

10.2.3.2 Detailed Design Procedure

For the design procedure, see [Detailed Design Procedure](#).

10.2.3.3 Application Curves

For application curves, see the figures listed in [Table 8](#).

10.2.4 LED Driver for Digital Still Cameras

Use the boost converter of the TPA2013D1 as a power supply for the flash LED of a digital still camera. Use a microprocessor or other device or synchronize the flash to shutter sound that typically comes from the speaker of a digital still camera. [Figure 36](#) shows a typical circuit for this application. LEDs, switches, and other components varies by application.

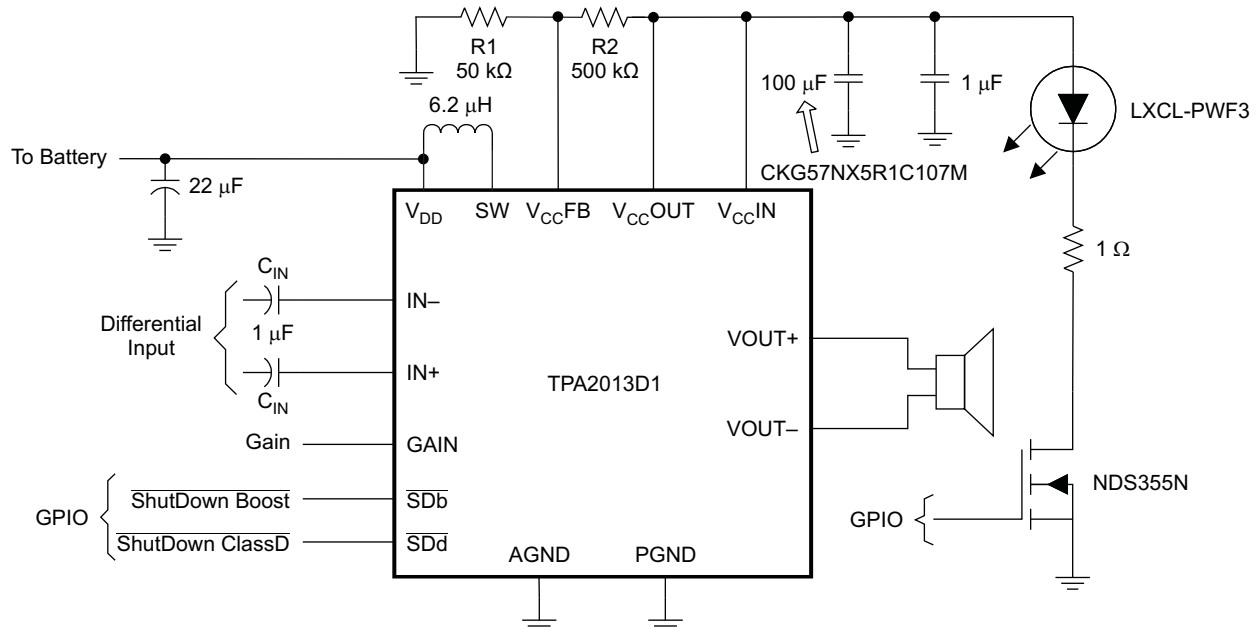

Figure 36. LED Driver

10.2.5 Design Requirements

For this design example, use the parameters listed in [Table 5](#).

10.2.6 Detailed Design Procedure

For the design procedure, see [Detailed Design Procedure](#).

10.2.7 Application Curves

For application curves, see the figures listed in [Table 8](#).

11 Power Supply Recommendations

The TPA2013D1 is designed to operate from an input voltage supply range from 1.8 V to 5.5 V. Therefore, the output voltage range of the power supply should be within this range. The current capability of upper power must not exceed the maximum current limit of the power switch.

11.1 Power Supply Decoupling Capacitors

The TPA2013D1 requires adequate power-supply decoupling to ensure a high-efficiency operation with low total harmonic distortion (THD). Place a low equivalent-series-resistance (ESR) ceramic capacitor, typically 0.1 μF , within 2 mm of the VDD/VCCOUT pin. This choice of capacitor and placement helps with higher-frequency transients, spikes, or digital hash on the line. In addition to the 0.1- μF ceramic capacitor, TI recommends placing a 2.2- μF to 10- μF capacitor on the VDD supply trace. This larger capacitor acts as a charge reservoir, providing energy faster than the board supply, thus helping to prevent any droop in the supply voltage.

12 Layout

12.1 Layout Guidelines

12.1.1 Component Placement

Place all the external components close to the TPA2013D1 device. Placing the decoupling capacitors as close to the device as possible is important for the efficiency of the class-D amplifier. Any resistance or inductance in the trace between the device and the capacitor can cause a loss in efficiency

12.1.1.1 Trace Width

Recommended trace width at the solder balls is 75 μm to 100 μm to prevent solder wicking onto wider PCB traces.

For high current pins (SW, PGND, VOUT+, VOUT-, V_{CC}IN, and V_{CC}OUT) of the TPA2013D1, use 100- μm trace widths at the solder balls and at least 500- μm PCB traces to ensure proper performance and output power for the device.

For low current pins (IN-, IN+, $\overline{\text{SDd}}$, $\overline{\text{SDb}}$, GAIN, V_{CC}FB, V_{DD}) of the TPA2013D1, use 75- μm to 100- μm trace widths at the solder balls. Run IN- and IN+ traces side-by-side to maximize common-mode noise cancellation.

12.1.2 Pad Side

In making the pad size for the WCSP balls, use nonsolder mask defined (NSMD) land. With this method, the solder mask opening is made larger than the desired land area, and the opening size is defined by the copper pad width. [Figure 37](#) and [Table 9](#) show the appropriate diameters for a WCSP layout.

Layout Guidelines (continued)

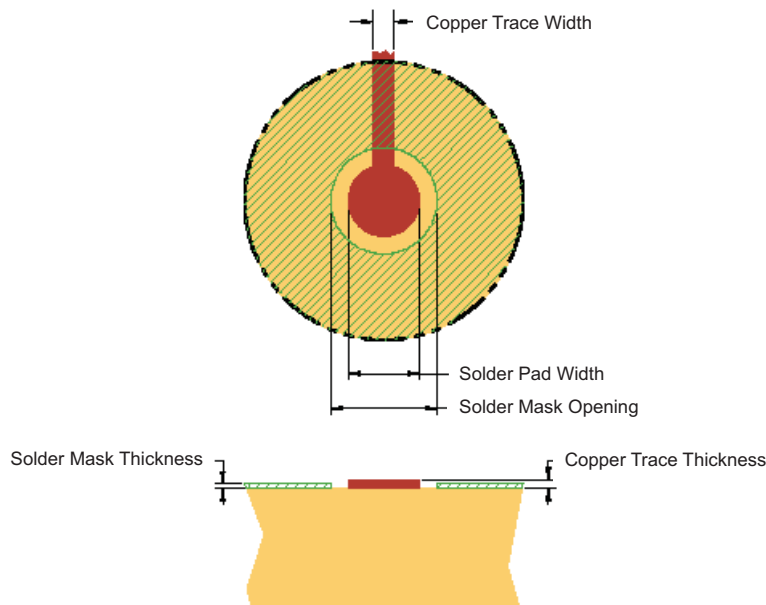

Figure 37. Land Pattern Dimensions

Table 9. Land Pattern Dimensions

SOLDER PAD DEFINITIONS	COPPER PAD	SOLDER MASK OPENING	COPPER THICKNESS	STENCIL OPENING	STENCIL THICKNESS
Nonsolder mask defined (NSMD)	275 μm (+0.0, -25 μm)	375 μm (+0.0, -25 μm)	1 oz max (32 μm)	275 μm x 275 μm Sq. (rounded corners)	125 μm thick

NOTES:

1. Circuit traces from NSMD defined PWB lands should be 75 μm to 100 μm wide in the exposed area inside the solder mask opening. Wider trace widths reduce device stand off and impact reliability.
2. Recommend solder paste is Type 3 or Type 4.
3. Best reliability results are achieved when the PWB laminate glass transition temperature is above the operating range of the intended application.
4. For a PWB using a Ni/Au surface finish, the gold thickness should be less 0.5 μm to avoid a reduction in thermal fatigue performance.
5. Solder mask thickness should be less than 20 μm on top of the copper circuit pattern.
6. Best solder stencil performance is achieved using laser cut stencils with electro polishing. Use of chemically etched stencils results in inferior solder paste volume control.
7. Trace routing away from WCSP device should be balanced in X and Y directions to avoid unintentional component movement due to solder wetting forces.

12.2 Layout Examples

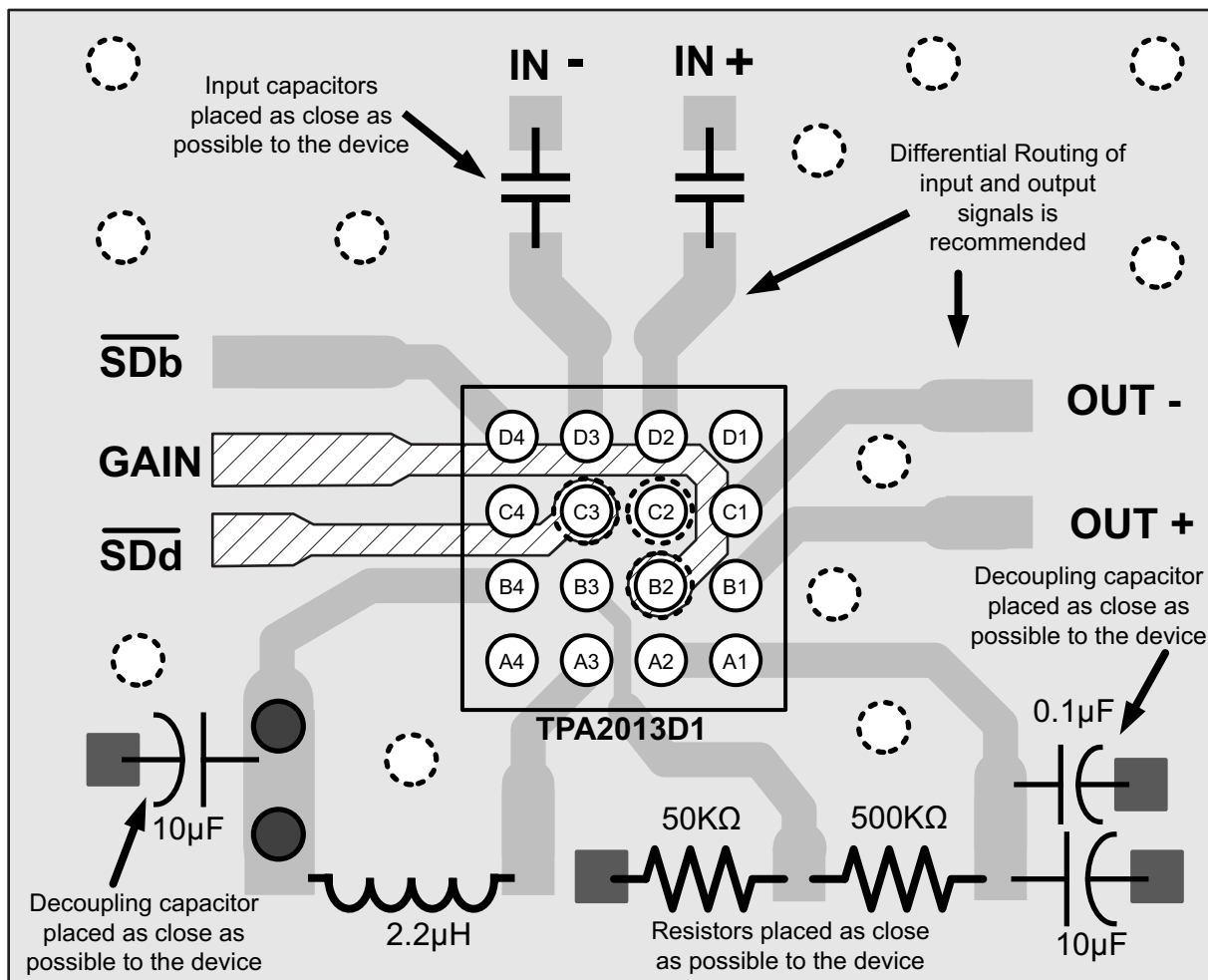

Figure 38. TPA2015BGA Layout

Layout Examples (continued)

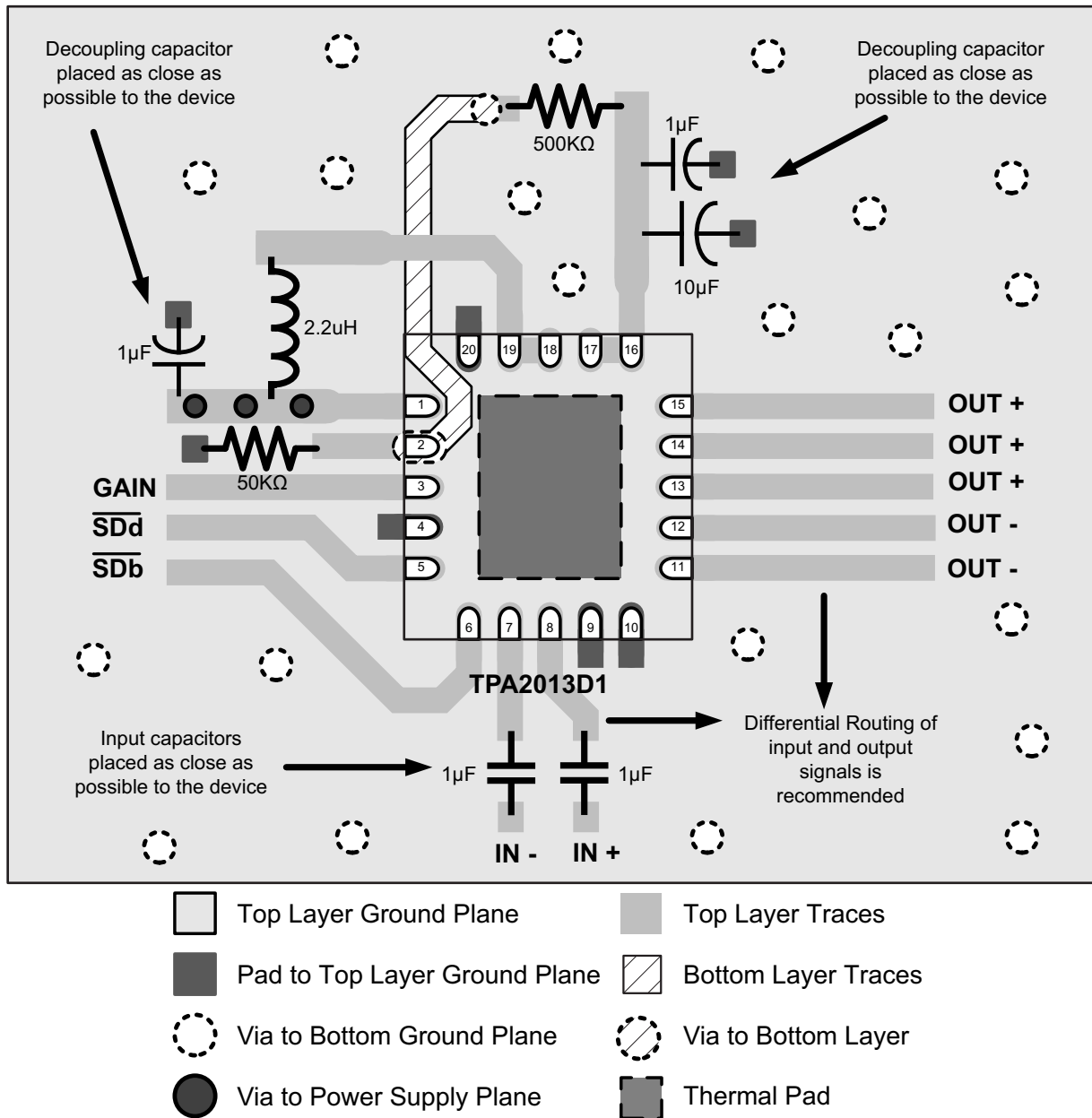

Figure 39. TPA2015QFN Layout

12.3 Efficiency and Thermal Considerations

The maximum ambient temperature depends on the heat-sinking ability of the PCB system. The derating factors for the YZH and RGP packages are shown in [Dissipation Ratings](#). Apply the same principles to both packages. Using the YZH package, and converting this to θ_{JA} :

$$\theta_{JA} = \frac{1}{\text{Derating Factor}} = \frac{1}{0.0124} = 80.64^{\circ}\text{C/W} \tag{8}$$

Given θ_{JA} of 80.64°C/W, the maximum allowable junction temperature of 150°C, and the maximum internal dissipation of 0.317 W ($V_{DD} = 3.6$ V, $P_O = 1.7$ W), the maximum ambient temperature is calculated with [Equation 9](#):

Efficiency and Thermal Considerations (continued)

$$T_{A\text{Max}} = T_{J\text{Max}} - \theta_{JA} P_{D\text{max}} = 150 - 80.64 (0.317) = 124^{\circ}\text{C} \quad (9)$$

Equation 9 shows that the calculated maximum ambient temperature is 124°C at maximum power dissipation under the above conditions. The TPA2013D1 is designed with thermal protection that turns the device off when the junction temperature surpasses 150°C to prevent damage to the IC. Also, using speakers more resistive than 4-Ω dramatically increases the thermal performance by reducing the output current and increasing the efficiency of the amplifier.

13 Device and Documentation Support

13.1 Device Support

13.1.1 Third-Party Products Disclaimer

TI'S PUBLICATION OF INFORMATION REGARDING THIRD-PARTY PRODUCTS OR SERVICES DOES NOT CONSTITUTE AN ENDORSEMENT REGARDING THE SUITABILITY OF SUCH PRODUCTS OR SERVICES OR A WARRANTY, REPRESENTATION OR ENDORSEMENT OF SUCH PRODUCTS OR SERVICES, EITHER ALONE OR IN COMBINATION WITH ANY TI PRODUCT OR SERVICE.

13.1.2 Device Nomenclature

13.1.2.1 Boost Terms

The following is a list of terms and definitions used in the boost equations found in this document.

C	Minimum boost capacitance required for a given ripple voltage on V_{CC} .
L	Boost inductor
f_{boost}	Switching frequency of the boost converter.
I_{CC}	Current pulled by the Class-D amplifier from the boost converter.
I_L	Average current through the boost inductor.
R1 and R2	Resistors used to set the boost voltage.
V_{CC}	Boost voltage. Generated by the boost converter. Voltage supply for the Class-D amplifier.
V_{DD}	Supply voltage to the IC.
ΔI_L	Ripple current through the inductor.
ΔV	Ripple voltage on V_{CC} due to capacitance.

13.2 Community Resources

The following links connect to TI community resources. Linked contents are provided "AS IS" by the respective contributors. They do not constitute TI specifications and do not necessarily reflect TI's views; see TI's [Terms of Use](#).

TI E2E™ Online Community *TI's Engineer-to-Engineer (E2E) Community*. Created to foster collaboration among engineers. At e2e.ti.com, you can ask questions, share knowledge, explore ideas and help solve problems with fellow engineers.

Design Support *TI's Design Support* Quickly find helpful E2E forums along with design support tools and contact information for technical support.

13.3 Trademarks

E2E is a trademark of Texas Instruments.
All other trademarks are the property of their respective owners.

13.4 Electrostatic Discharge Caution



These devices have limited built-in ESD protection. The leads should be shorted together or the device placed in conductive foam during storage or handling to prevent electrostatic damage to the MOS gates.

13.5 Glossary

SLYZ022 — *TI Glossary*.

This glossary lists and explains terms, acronyms, and definitions.

14 Mechanical, Packaging, and Orderable Information

The following pages include mechanical, packaging, and orderable information. This information is the most current data available for the designated devices. This data is subject to change without notice and revision of this document. For browser-based versions of this data sheet, refer to the left-hand navigation.

PACKAGING INFORMATION

Orderable part number	Status (1)	Material type (2)	Package Pins	Package qty Carrier	RoHS (3)	Lead finish/ Ball material (4)	MSL rating/ Peak reflow (5)	Op temp (°C)	Part marking (6)
TPA2013D1RGPR	Active	Production	QFN (RGP) 20	3000 LARGE T&R	Yes	NIPDAU	Level-3-260C-168 HR	-40 to 85	BTI
TPA2013D1RGPR.Z	Active	Production	QFN (RGP) 20	3000 LARGE T&R	Yes	NIPDAU	Level-3-260C-168 HR	-40 to 85	BTI
TPA2013D1RGPRG4.Z	Active	Production	QFN (RGP) 20	3000 LARGE T&R	Yes	NIPDAU	Level-3-260C-168 HR	-40 to 85	BTI
TPA2013D1YZHR	Active	Production	DSBGA (YZH) 16	3000 LARGE T&R	Yes	SNAGCU	Level-1-260C-UNLIM	-40 to 85	BTH
TPA2013D1YZHR.Z	Active	Production	DSBGA (YZH) 16	3000 LARGE T&R	Yes	SNAGCU	Level-1-260C-UNLIM	-40 to 85	BTH

(1) **Status:** For more details on status, see our [product life cycle](#).

(2) **Material type:** When designated, preproduction parts are prototypes/experimental devices, and are not yet approved or released for full production. Testing and final process, including without limitation quality assurance, reliability performance testing, and/or process qualification, may not yet be complete, and this item is subject to further changes or possible discontinuation. If available for ordering, purchases will be subject to an additional waiver at checkout, and are intended for early internal evaluation purposes only. These items are sold without warranties of any kind.

(3) **RoHS values:** Yes, No, RoHS Exempt. See the [TI RoHS Statement](#) for additional information and value definition.

(4) **Lead finish/Ball material:** Parts may have multiple material finish options. Finish options are separated by a vertical ruled line. Lead finish/Ball material values may wrap to two lines if the finish value exceeds the maximum column width.

(5) **MSL rating/Peak reflow:** The moisture sensitivity level ratings and peak solder (reflow) temperatures. In the event that a part has multiple moisture sensitivity ratings, only the lowest level per JEDEC standards is shown. Refer to the shipping label for the actual reflow temperature that will be used to mount the part to the printed circuit board.

(6) **Part marking:** There may be an additional marking, which relates to the logo, the lot trace code information, or the environmental category of the part.

Multiple part markings will be inside parentheses. Only one part marking contained in parentheses and separated by a "-" will appear on a part. If a line is indented then it is a continuation of the previous line and the two combined represent the entire part marking for that device.

Important Information and Disclaimer:The information provided on this page represents TI's knowledge and belief as of the date that it is provided. TI bases its knowledge and belief on information provided by third parties, and makes no representation or warranty as to the accuracy of such information. Efforts are underway to better integrate information from third parties. TI has taken and continues to take reasonable steps to provide representative and accurate information but may not have conducted destructive testing or chemical analysis on incoming materials and chemicals. TI and TI suppliers consider certain information to be proprietary, and thus CAS numbers and other limited information may not be available for release.

In no event shall TI's liability arising out of such information exceed the total purchase price of the TI part(s) at issue in this document sold by TI to Customer on an annual basis.

TAPE AND REEL INFORMATION

QUADRANT ASSIGNMENTS FOR PIN 1 ORIENTATION IN TAPE

*All dimensions are nominal

Device	Package Type	Package Drawing	Pins	SPQ	Reel Diameter (mm)	Reel Width W1 (mm)	A0 (mm)	B0 (mm)	K0 (mm)	P1 (mm)	W (mm)	Pin1 Quadrant
TPA2013D1RGPR	QFN	RGP	20	3000	330.0	12.4	4.25	4.25	1.15	8.0	12.0	Q2
TPA2013D1YZHR	DSBGA	YZH	16	3000	180.0	8.4	2.35	2.35	0.81	4.0	8.0	Q1

TAPE AND REEL BOX DIMENSIONS

*All dimensions are nominal

Device	Package Type	Package Drawing	Pins	SPQ	Length (mm)	Width (mm)	Height (mm)
TPA2013D1RGPR	QFN	RGP	20	3000	356.0	356.0	35.0
TPA2013D1YZHR	DSBGA	YZH	16	3000	182.0	182.0	20.0

GENERIC PACKAGE VIEW

RGP 20

VQFN - 1 mm max height

4 x 4, 0.5 mm pitch

VERY THIN QUAD FLATPACK

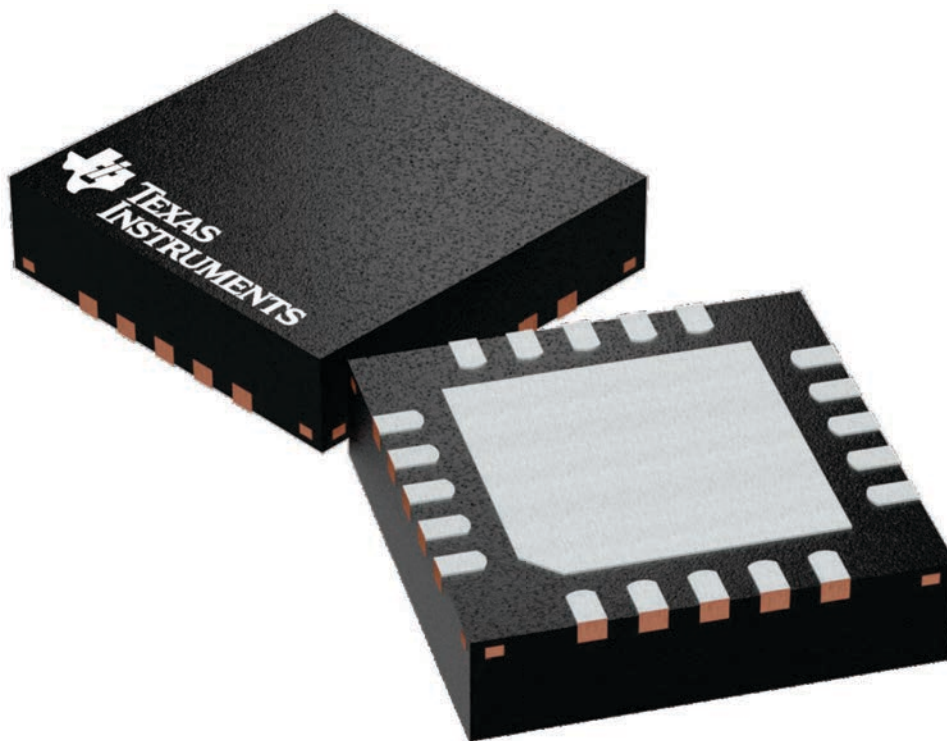

Images above are just a representation of the package family, actual package may vary.
Refer to the product data sheet for package details.

4224735/A

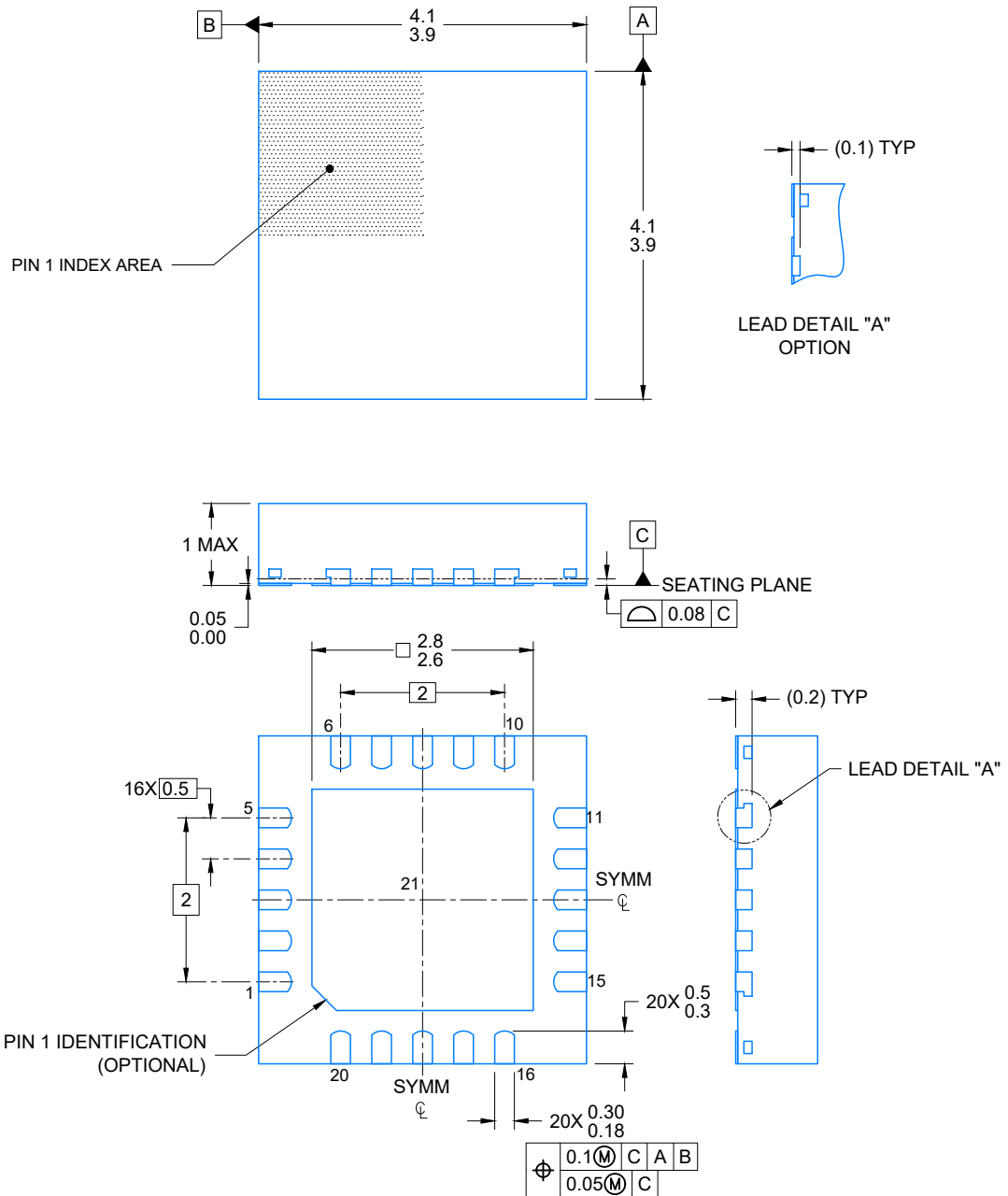

4219028/A 12/2018

NOTES:

1. All linear dimensions are in millimeters. Any dimensions in parenthesis are for reference only. Dimensioning and tolerancing per ASME Y14.5M.
2. This drawing is subject to change without notice.
3. The package thermal pad must be soldered to the printed circuit board for optimal thermal and mechanical performance.

EXAMPLE BOARD LAYOUT

VQFN - 1 mm max height

RGP0020D

PLASTIC QUAD FLATPACK- NO LEAD

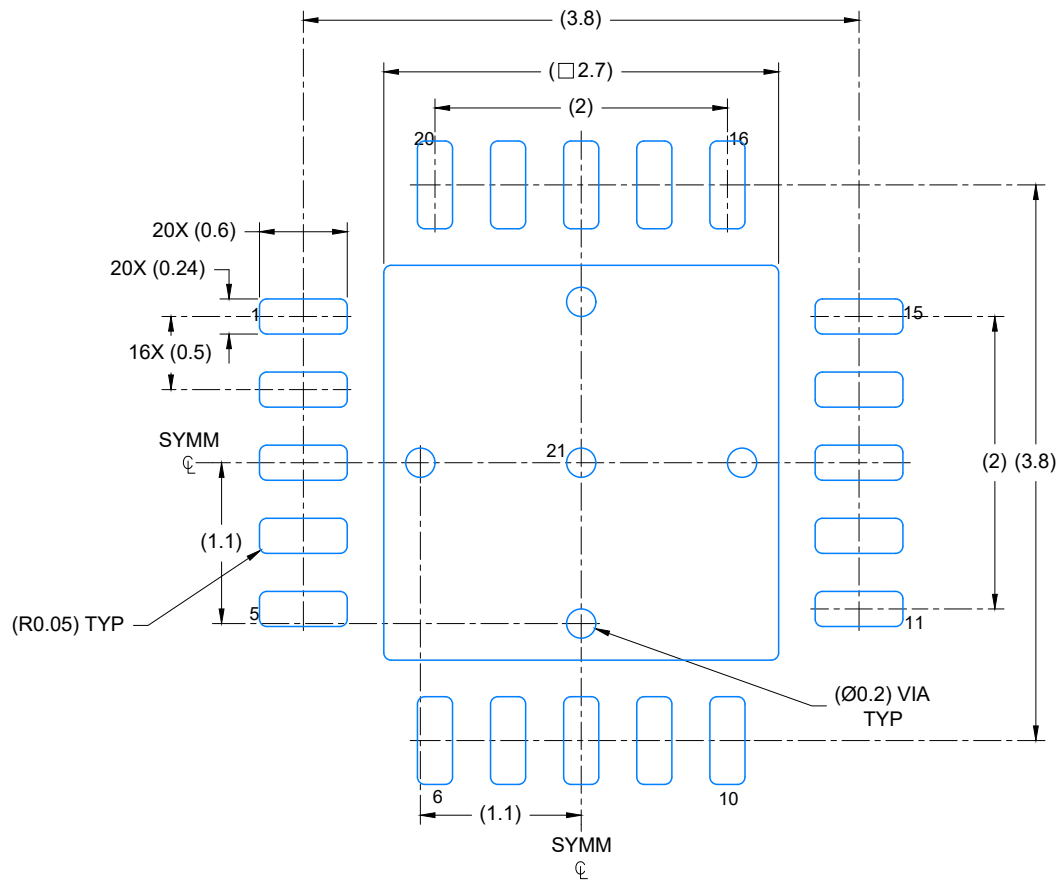

LAND PATTERN EXAMPLE
EXPOSED METAL SHOWN
SCALE: 20X

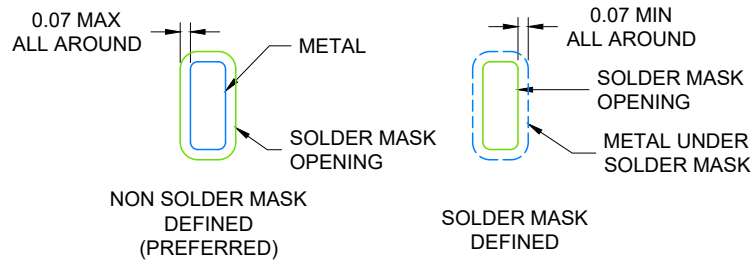

SOLDER MASK DETAILS

4219028/A 12/2018

NOTES: (continued)

4. This package is designed to be soldered to a thermal pad on the board. For more information, see Texas Instruments literature number SLUA271 (www.ti.com/lit/sluea271).
5. Vias are optional depending on application, refer to device data sheet. If any vias are implemented, refer to their locations shown on this view. It is recommended that vias under paste be filled, plugged or tented.

EXAMPLE STENCIL DESIGN

RGP0020D

VQFN - 1 mm max height

PLASTIC QUAD FLATPACK- NO LEAD

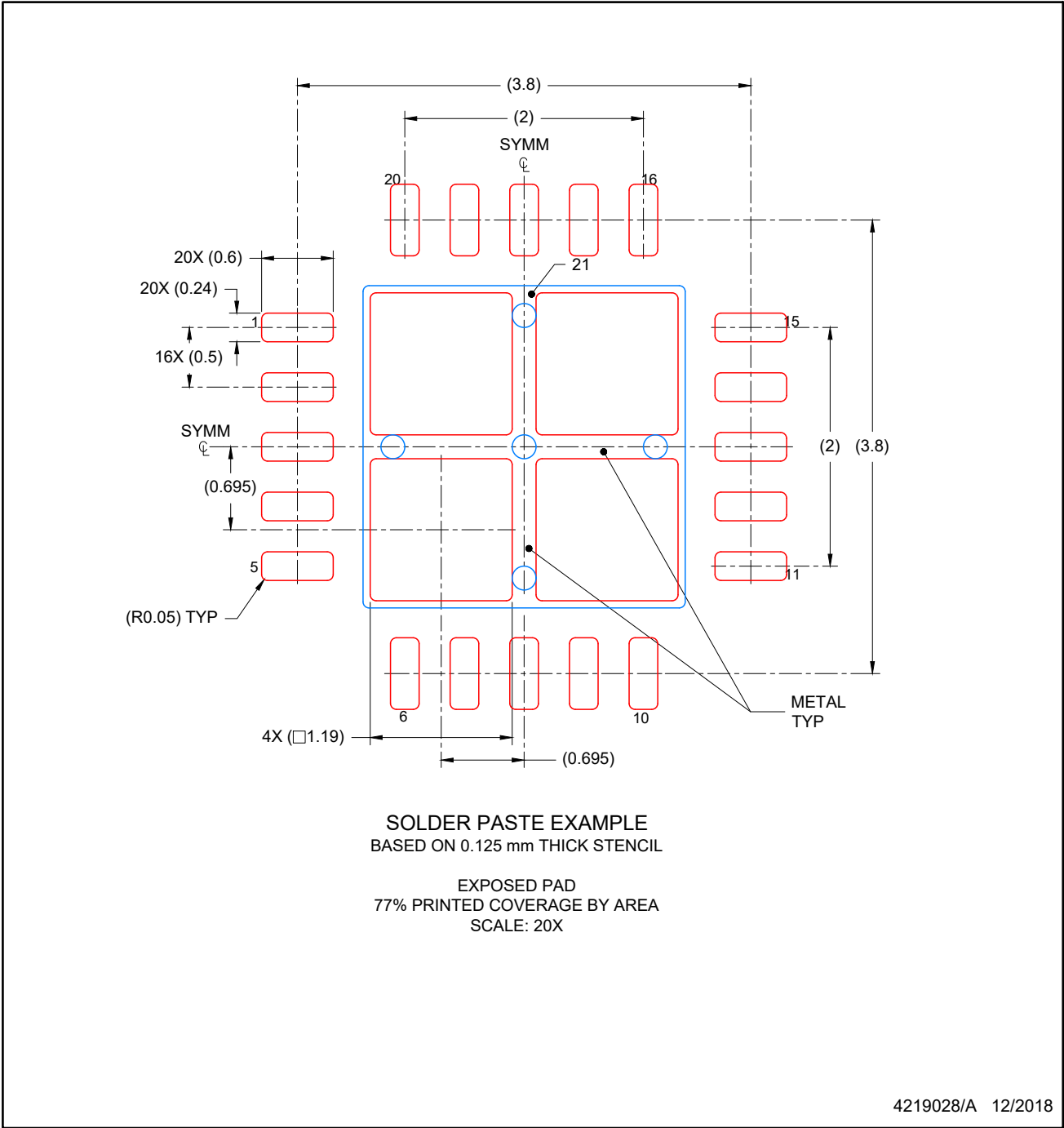

NOTES: (continued)

- 6. Laser cutting apertures with trapezoidal walls and rounded corners may offer better paste release. IPC-7525 may have alternate design recommendations.

YZH0016

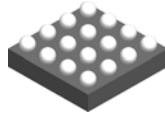

PACKAGE OUTLINE

DSBGA - 0.625 mm max height

DIE SIZE BALL GRID ARRAY

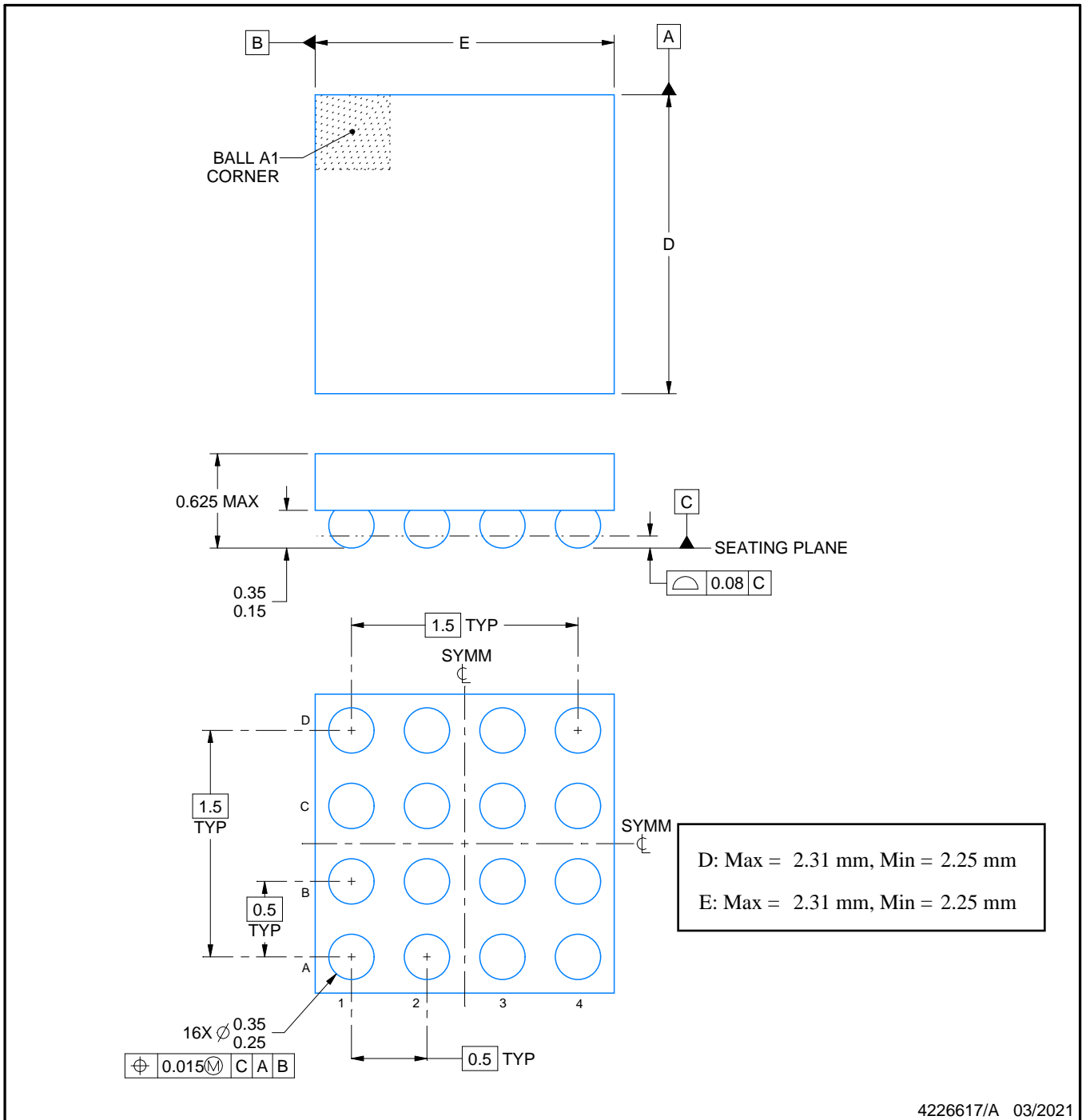

NOTES:

1. All linear dimensions are in millimeters. Any dimensions in parenthesis are for reference only. Dimensioning and tolerancing per ASME Y14.5M.
2. This drawing is subject to change without notice.

EXAMPLE BOARD LAYOUT

YZH0016

DSBGA - 0.625 mm max height

DIE SIZE BALL GRID ARRAY

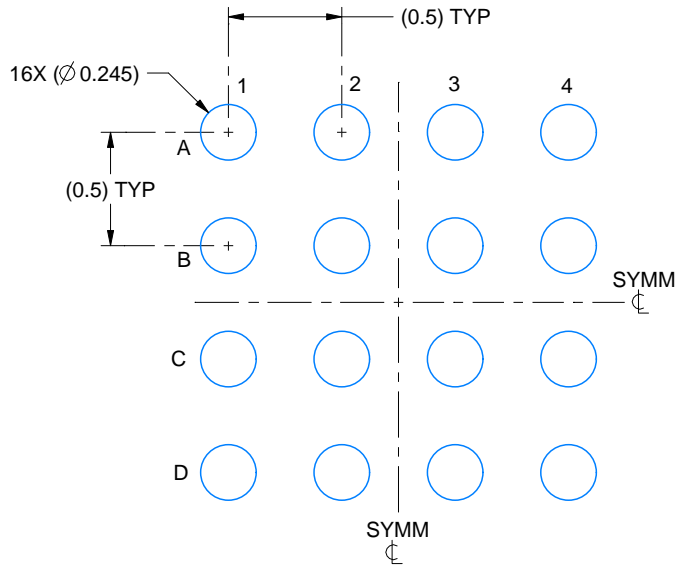

LAND PATTERN EXAMPLE
EXPOSED METAL SHOWN
SCALE: 30X

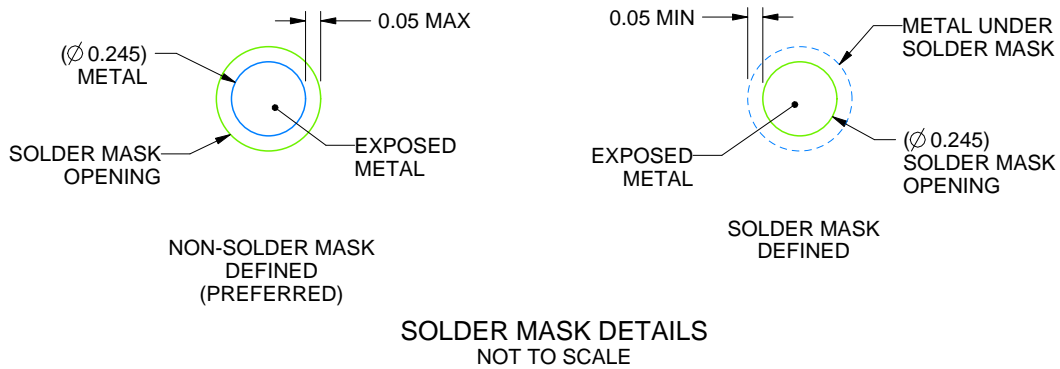

SOLDER MASK DETAILS
NOT TO SCALE

4226617/A 03/2021

NOTES: (continued)

- 3. Final dimensions may vary due to manufacturing tolerance considerations and also routing constraints. See Texas Instruments Literature No. SNVA009 (www.ti.com/lit/snva009).

EXAMPLE STENCIL DESIGN

YZH0016

DSBGA - 0.625 mm max height

DIE SIZE BALL GRID ARRAY

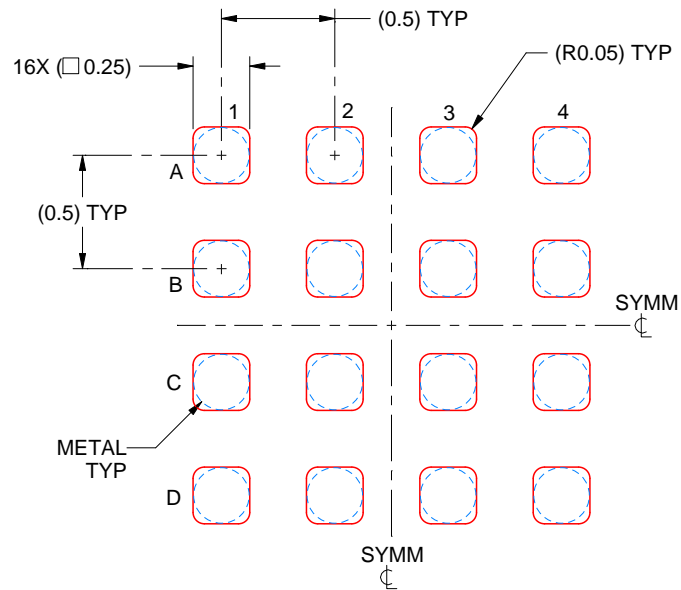

SOLDER PASTE EXAMPLE
BASED ON 0.075 mm THICK STENCIL
SCALE: 30X

4226617/A 03/2021

NOTES: (continued)

4. Laser cutting apertures with trapezoidal walls and rounded corners may offer better paste release.

IMPORTANT NOTICE AND DISCLAIMER

TI PROVIDES TECHNICAL AND RELIABILITY DATA (INCLUDING DATA SHEETS), DESIGN RESOURCES (INCLUDING REFERENCE DESIGNS), APPLICATION OR OTHER DESIGN ADVICE, WEB TOOLS, SAFETY INFORMATION, AND OTHER RESOURCES "AS IS" AND WITH ALL FAULTS, AND DISCLAIMS ALL WARRANTIES, EXPRESS AND IMPLIED, INCLUDING WITHOUT LIMITATION ANY IMPLIED WARRANTIES OF MERCHANTABILITY, FITNESS FOR A PARTICULAR PURPOSE OR NON-INFRINGEMENT OF THIRD PARTY INTELLECTUAL PROPERTY RIGHTS.

These resources are intended for skilled developers designing with TI products. You are solely responsible for (1) selecting the appropriate TI products for your application, (2) designing, validating and testing your application, and (3) ensuring your application meets applicable standards, and any other safety, security, regulatory or other requirements.

These resources are subject to change without notice. TI grants you permission to use these resources only for development of an application that uses the TI products described in the resource. Other reproduction and display of these resources is prohibited. No license is granted to any other TI intellectual property right or to any third party intellectual property right. TI disclaims responsibility for, and you will fully indemnify TI and its representatives against, any claims, damages, costs, losses, and liabilities arising out of your use of these resources.

TI's products are provided subject to [TI's Terms of Sale](#) or other applicable terms available either on [ti.com](https://www.ti.com) or provided in conjunction with such TI products. TI's provision of these resources does not expand or otherwise alter TI's applicable warranties or warranty disclaimers for TI products.

TI objects to and rejects any additional or different terms you may have proposed.

Mailing Address: Texas Instruments, Post Office Box 655303, Dallas, Texas 75265

Copyright © 2025, Texas Instruments Incorporated