

TPPM0115 SWITCH MODE SYNCHRONOUS BUCK CONTROLLER

SLVS371A– MARCH 2001 – REVISED JUNE 2001

features

- DC-DC Synchronous Buck Controller
- Switching Frequency, 200 kHz (Typ)
- Programmable Output Voltage, 1 V to 2.5 V \pm 2%
- Power Good Function (PWRGD)
- Input Voltage, 12 V \pm 5%
- Drive High Load Current With External Components

applications

- PC Motherboard, Voltage Regulation for System Power
- DDR Memory Supply (V_{DDQ} or V_{TT})
- RDRAM Memory Supply (V_{DDQ})
- General Purpose Synchronous Switch Mode Controller

description

The TPPM0115 is a synchronous buck controller capable of driving two external power FETs 180° out of phase. The device requires a minimum of external standard filter components and switching FETs to regulate the desired output voltage. This is achieved with an internal switching frequency of 200 kHz (typical).

The TPPM0115 switch mode controller and associated circuitry provide efficient voltage regulation of greater than 85%. The output voltage is set by two external resistors. During power up, when the output voltage reaches 90% of the desired value, the power good (PWRGD) output is transitioned high after a short delay of 1 ms to 5 ms. During power down, when the output voltage falls below 90% of the set value, the PWRGD output is pulled low without any delay.

In the event the set output is in an over-voltage condition due to a system fault, the drive to the lower FET turns on to correct the fault. There is a dead time between switching one FET ON while the other FET is switching OFF to prevent cross conduction.

The TPPM0115 is capable of driving high static load currents with minimal ripple on the output (<2%). The phase sense input is used to sense the flow of current through the inductor during flyback to minimize ripple on the output.

To optimize output filter capacitance, the voltage mode control is based on a fixed ON time during the start of the cycle and hysteretic control during load transients. This allows the device to respond and maintain the set regulation voltage.

SO (D) PACKAGE
(TOP VIEW)

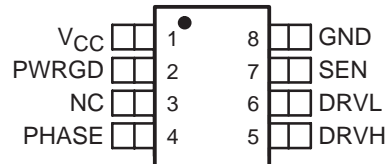

NC – No internal connection



Please be aware that an important notice concerning availability, standard warranty, and use in critical applications of Texas Instruments semiconductor products and disclaimers thereto appears at the end of this data sheet.

PRODUCTION DATA information is current as of publication date. Products conform to specifications per the terms of Texas Instruments standard warranty. Production processing does not necessarily include testing of all parameters.

 **TEXAS
INSTRUMENTS**

POST OFFICE BOX 655303 • DALLAS, TEXAS 75265

Copyright © 2001, Texas Instruments Incorporated

TPPM0115 SWITCH MODE SYNCHRONOUS BUCK CONTROLLER

SLVS371A- MARCH 2001 – REVISED JUNE 2001

functional block diagram

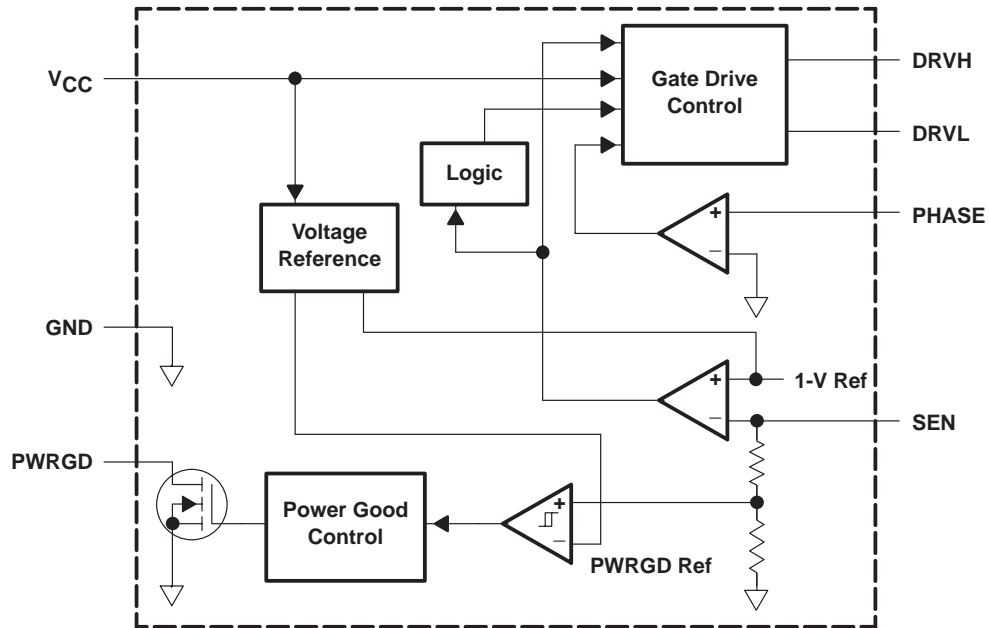

Terminal Functions

TERMINAL NAME	NO.	I/O	DESCRIPTION
DRVH	5	O	Output for upper FET gate drive
DRVL	6	O	Output for lower FET gate drive
GND	8	O	Ground
NC/TEST	3	O	No connection, used for test purpose only
PHASE	4	I	Phase sense input
PWRGD	2	O	Open-drain output for power good function
SEN	7	I	Sense input
VCC	1	I	Input voltage

TPPM0115

SWITCH MODE SYNCHRONOUS BUCK CONTROLLER

SLVS371A– MARCH 2001 – REVISED JUNE 2001

absolute maximum ratings over operating free-air temperature (unless otherwise noted)†

Unregulated input voltage, V_{CC} (see Notes 1 and 2)	24 V
Drive output voltage, $V_{(DRVH)}$ and $V_{(DRVL)}$ (see Notes 1 and 3)	12.6 V
Power good voltage, $V_{(PWRGD)}$ (see Notes 1 and 2)	7 V
Feedback voltage, $V_{(SEN)}$ (see Notes 1 and 2)	7 V
Phase sense voltage, $V_{(PHASE)}$ (see Note 3)	7 V
Continuous power dissipation, P_D	0.4 W
Electrostatic discharge susceptibility, $V_{(HBMESD)}$ (see Note 4)	2 kV
Operating ambient temperature range, T_A	0°C to 70°C
Storage temperature range, T_{stg}	–65°C to 150°C
Lead temperature (soldering, 10 sec) T_{LEAD}	260°C

† Stresses beyond those listed under “absolute maximum ratings” may cause permanent damage to the device. These are stress ratings only, and functional operation of the device at these or any other conditions beyond those indicated under “recommended operating conditions” is not implied. Exposure to absolute-maximum-rated conditions for extended periods may affect device reliability.

- NOTES:
1. All voltage values are with respect to GND.
 2. Absolute negative voltage values on these terminals should not be below –0.5 V.
 3. Absolute negative voltage values on these terminals should not be below –1 V.
 4. The human body model is a 100-pF capacitor discharged through a 1.5-kΩ resistor into each terminal.

recommended operating conditions

	MIN	NOM	MAX	UNIT
Unregulated input voltage, V_{CC}	11.4		12.6	V
Drive output current, $I_{(DRVH)}$ and $I_{(DRVL)}$		500		mA
Power good voltage, $V_{(PWRGD)}$		5		V
Feedback voltage, $V_{(SEN)}$		1		V
Phase sense voltage, $V_{(PHASE)}$		0		V
Continuous power dissipation, P_D		100		mW
Operating ambient temperature, T_A		55		°C



TPPM0115

SWITCH MODE SYNCHRONOUS BUCK CONTROLLER

SLVS371A– MARCH 2001 – REVISED JUNE 2001

dc electrical characteristics, $T_A = 0^\circ\text{C}$ to 55°C , $V_{CC} = 12\text{ V}$ (unless otherwise noted)

PARAMETER		TEST CONDITIONS	MIN	TYP	MAX	UNIT
V_{OUT}	Output voltage	$V_{CC} = 11.4\text{ V}$ to 12.6 V , $I_L = 5\text{ A}$ to 10 A , See Figure 8 for external components, $R_1 = 0$, R_2 is not present	1			V
η	Efficiency	$I_L = 10\text{ A}$, See Figure 8	86%			
I_Q	Quiescent current	$V(\text{SEN}) = <1\text{ V}$ or $>1.3\text{ V}$, $V_{OUT} = 1\text{ V}$ to 1.3 V		2		mA
$\Delta V_O(\Delta I_O)$	Load regulation	See Figure 8	-1%		1%	
$\Delta V_O(\Delta V_I)$	Line regulation					
Temperature regulation						
$V_{OH}(\text{DRVH})$	Upper drive output voltage	$V(\text{SEN}) = 0.9\text{ V}$, $I_{OH} = 200\text{ mA}$	$V_{CC} - 3\text{V}$		1	V
$V_{OL}(\text{DRVH})$		$V(\text{SEN}) = 1.2\text{ V}$, $I_{OL} = -200\text{ mA}$				
$V_{OH}(\text{DRVL})$	Lower drive output voltage	$V(\text{SEN}) = 1.2\text{ V}$, $V(\text{PHASE}) < 0\text{ V}$	5		1	V
$V_{OL}(\text{DRVL})$		$V(\text{SEN}) = 0.9\text{ V}$, $I_{OL} = -200\text{ mA}$				
I_{IH}	Phase input current	$V(\text{SEN}) = 0.9\text{ V}$, $V(\text{PHASE}) = 5\text{ V}$	100			μA
I_{IL}		$V(\text{SEN}) = 1.2\text{ V}$, $V(\text{PHASE}) = -0.3\text{ V}$	-50			
$V(\text{PWRGD})$	Sense output voltage for PWRGD detection range	Ramp up sense input until PWRGD transition to high	V_{OUT}^* 0.86		V_{OUT}^* 0.96	V
		Ramp down sense input until PWRGD transition to low	V_{OUT}^* 0.63		V_{OUT}^* 0.71	
I_{BIAS}	Sense feedback bias current	$V(\text{SEN}) = 1.08\text{ V}$		5		μA

ac electrical characteristics, $T_A = 0^\circ\text{C}$ to 55°C , $V_{CC} = 12\text{ V}$ (unless otherwise noted)

PARAMETER		TEST CONDITIONS	MIN	TYP	MAX	UNIT
f_{sw}	Switching frequency	Measured at DRVH terminal		200		kHz
t_r	Output rise time for both DRVH and DRVL	$V(\text{DRVH}) \rightarrow 0\text{ V}$ to 8 V , $V(\text{SEN}) \rightarrow 1.1\text{ V}$ to 0.9 V		50		ns
		$V(\text{DRVL}) \rightarrow 0\text{ V}$ to 8 V , $V(\text{SEN}) \rightarrow 0.9\text{ V}$ to 1.1 V		50		
t_f	Output fall time for both DRVH and DRVL	$V(\text{DRVH}) \rightarrow 8\text{ V}$ to 0 V , $V(\text{SEN}) \rightarrow 0.9\text{ V}$ to 1.1 V		50		ns
		$V(\text{DRVL}) \rightarrow 8\text{ V}$ to 0 V , $V(\text{SEN}) \rightarrow 1.1\text{ V}$ to 0.9 V		50		
t_d	Power good signal delay	Delay time for $V(\text{SEN}) > V(\text{PWRGD})$ to PWRGD transitioning high	1		5	ms
t_{dt}	Dead time between DRVH and DRVL switch conduction	$V(\text{SEN}) \rightarrow 1.1\text{ V}$ to 0.9 V , Delay between $V(\text{DRVL})$ at 0 V and $V(\text{DRVH}) = 1.5\text{ V}$		50		ns
		$V(\text{SEN}) \rightarrow 0.9\text{ V}$ to 1.1 V , Delay between $V(\text{DRVH})$ at 0 V and $V(\text{DRVL}) = 1.5\text{ V}$		50		

thermal characteristics

		MIN	TYP	MAX	UNIT
$R_{\theta JC}$	Thermal impedance, junction-to-case			50	$^\circ\text{C}/\text{W}$
$R_{\theta JA}$	Thermal impedance, junction-to-ambient			178	$^\circ\text{C}/\text{W}$



TYPICAL CHARACTERISTICS

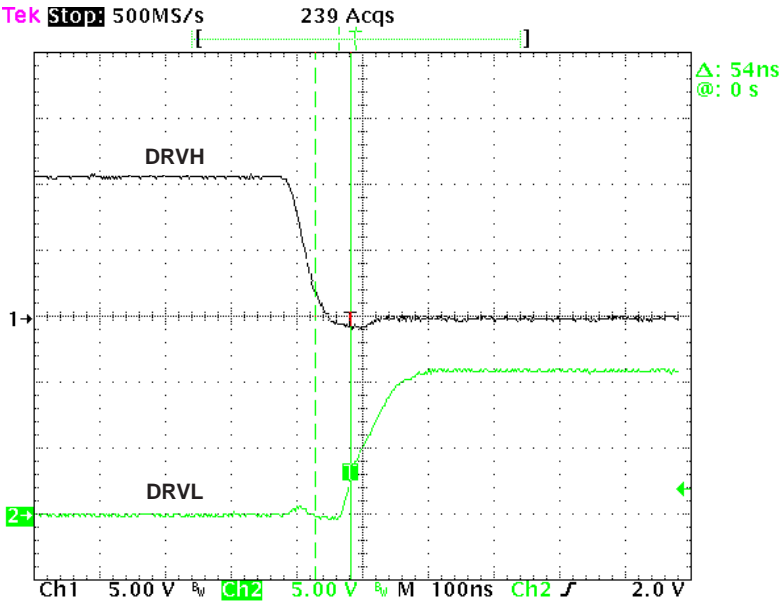

Figure 1. Dead Time Between Gate Drives Upper Switching OFF and Lower Switching ON

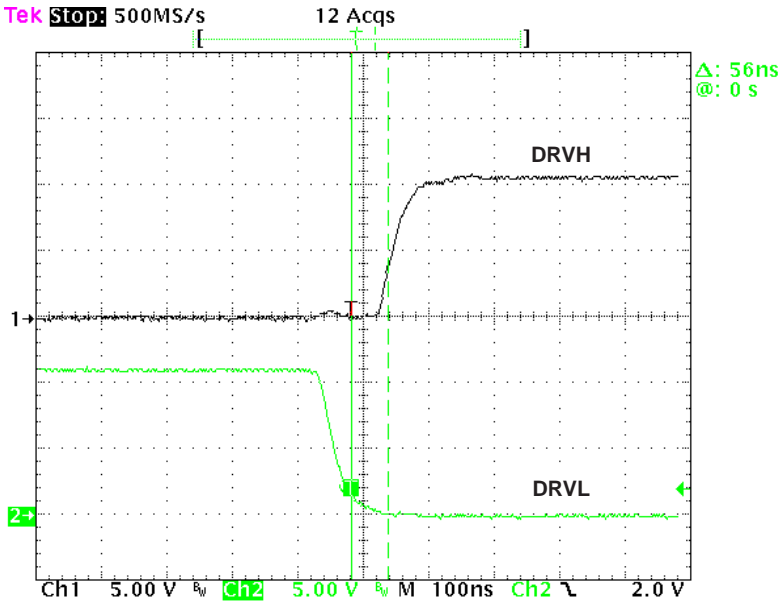

Figure 2. Dead Time Between Gate Drives Upper Switching ON and Lower Switching OFF

TPPM0115 SWITCH MODE SYNCHRONOUS BUCK CONTROLLER

SLVS371A- MARCH 2001 - REVISED JUNE 2001

TYPICAL CHARACTERISTICS

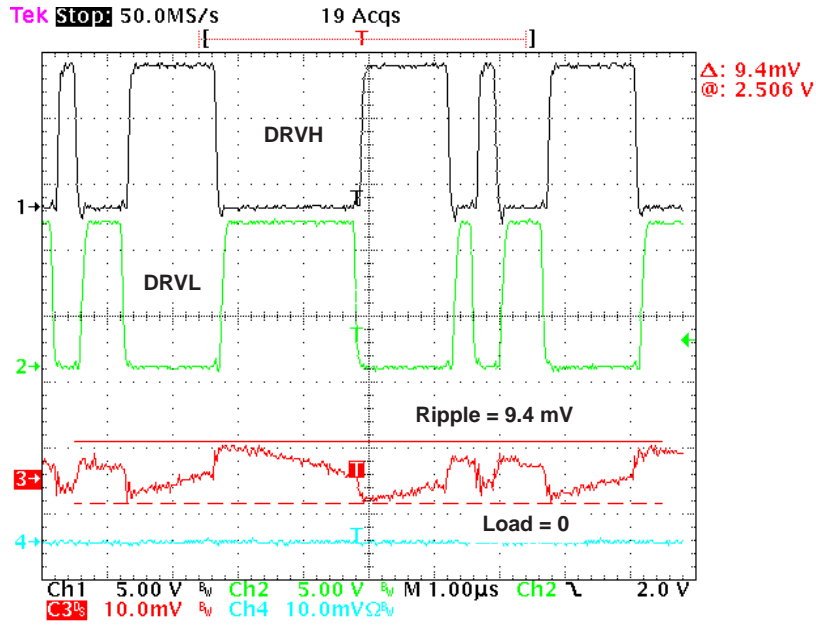

Figure 3. Output Voltage Ripple (Offset = 2.5 V) With NO Load

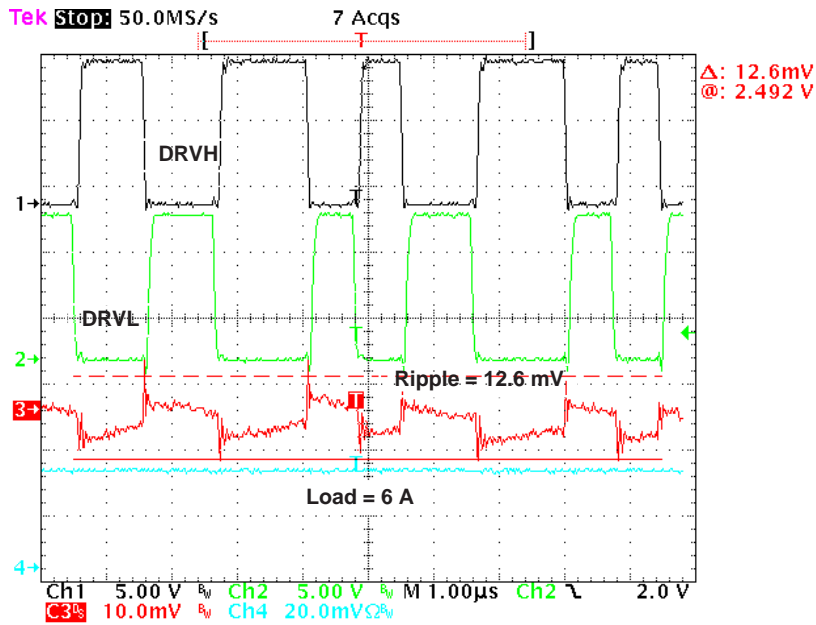

Figure 4. Output Voltage Ripple (Offset = 2.5 V) With 6 A Load

TYPICAL CHARACTERISTICS

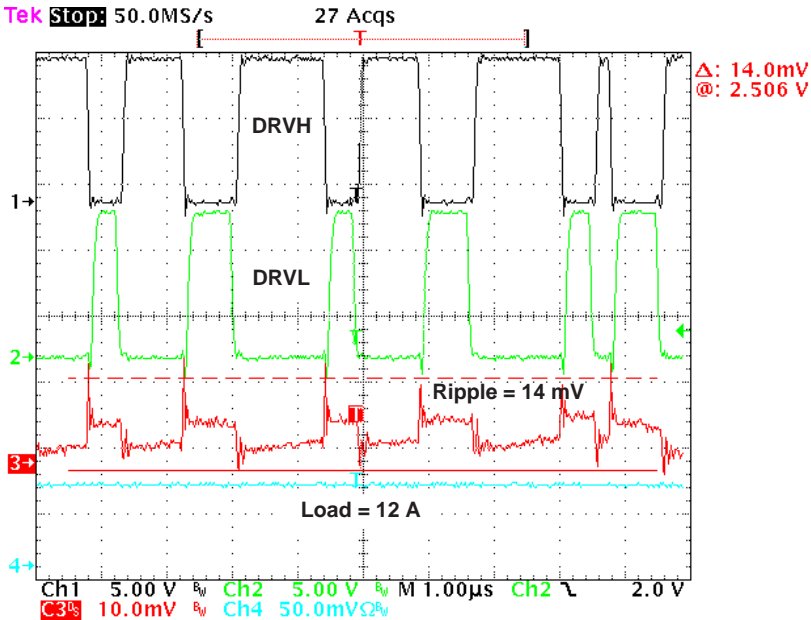

Figure 5. Output Voltage Ripple (Offset = 2.5 V) With 12 A Load

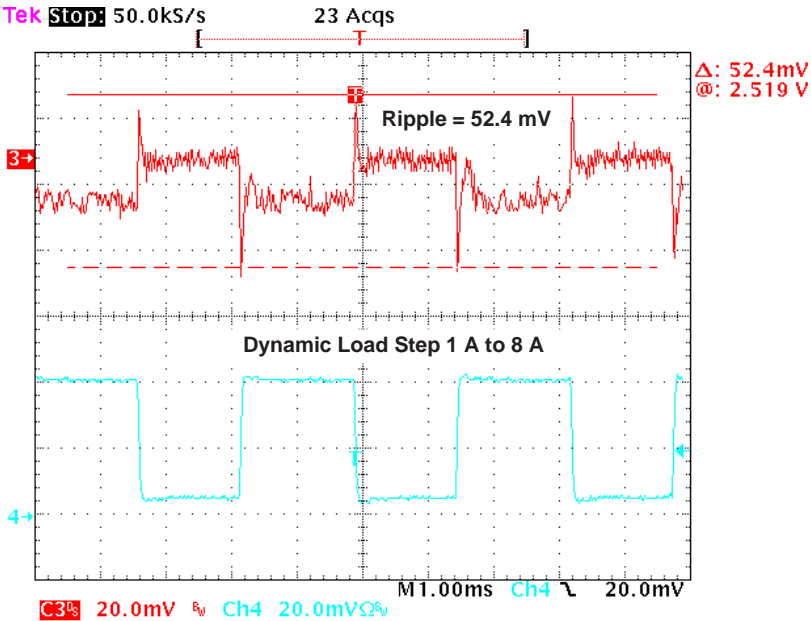

Figure 6. Output Voltage Ripple (Offset = 2.5 V) With Dynamic Load Switching (1 A to 8 A)

TPPM0115 SWITCH MODE SYNCHRONOUS BUCK CONTROLLER

SLVS371A- MARCH 2001 - REVISED JUNE 2001

TYPICAL CHARACTERISTICS

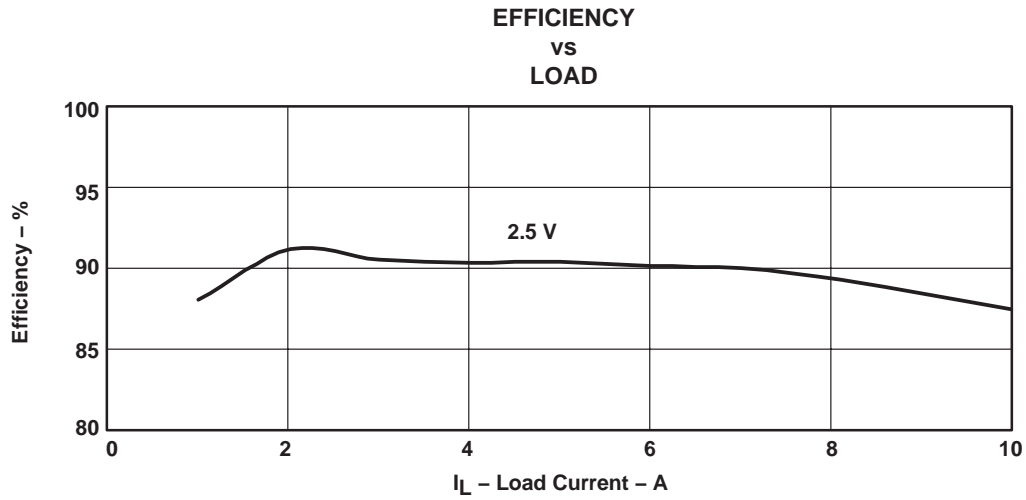
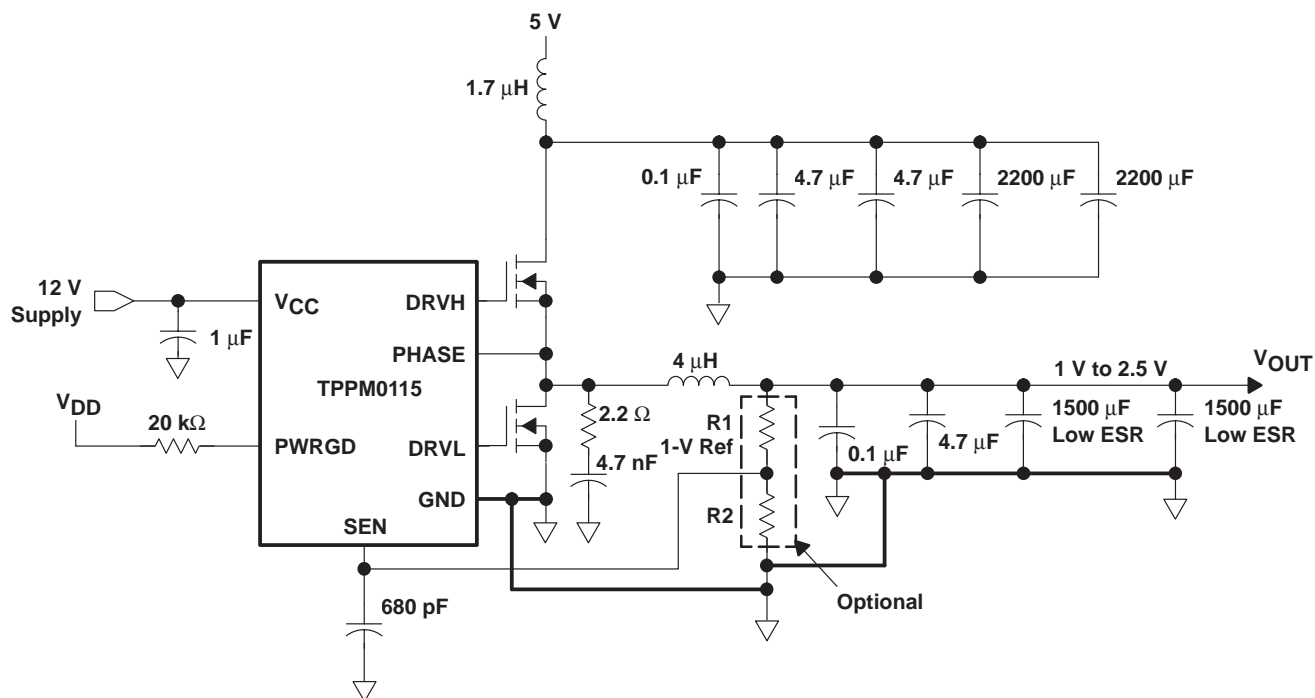

Figure 7. System Efficiency With Load Current (2.5-V Output)

APPLICATION INFORMATION



- NOTES:
- A. The heavy lines must be kept short and connected to the ground plane construction for efficient results.
 - B. The feedback (sense) trace should be kept from the inductor flux.
 - C. The 1500-µF capacitor should have a low ESR to minimize output voltage ripple.
 - D. External FETs are MTD3302 or PHD55N03LT.
 - E. Set the resistor values on the SEN terminal using the following formulas:

$$V_{OUT} = \frac{V_{ref}(R1 + R2)}{R2}, \text{ where } V_{ref} = 1 \text{ V}$$

- F. Maximum efficiency is dependent on proper selection of external components.
- G. Line and load regulation is dependent on proper selection of external components.

Optional: When resistor feedback network is not used, V_{OUT} must be connected directly to SEN input to provide output regulation at $V_{OUT} = V_{ref}$.

Figure 8. Typical Application Schematic

TPPM0115 SWITCH MODE SYNCHRONOUS BUCK CONTROLLER

SLVS371A- MARCH 2001 - REVISED JUNE 2001

APPLICATION INFORMATION

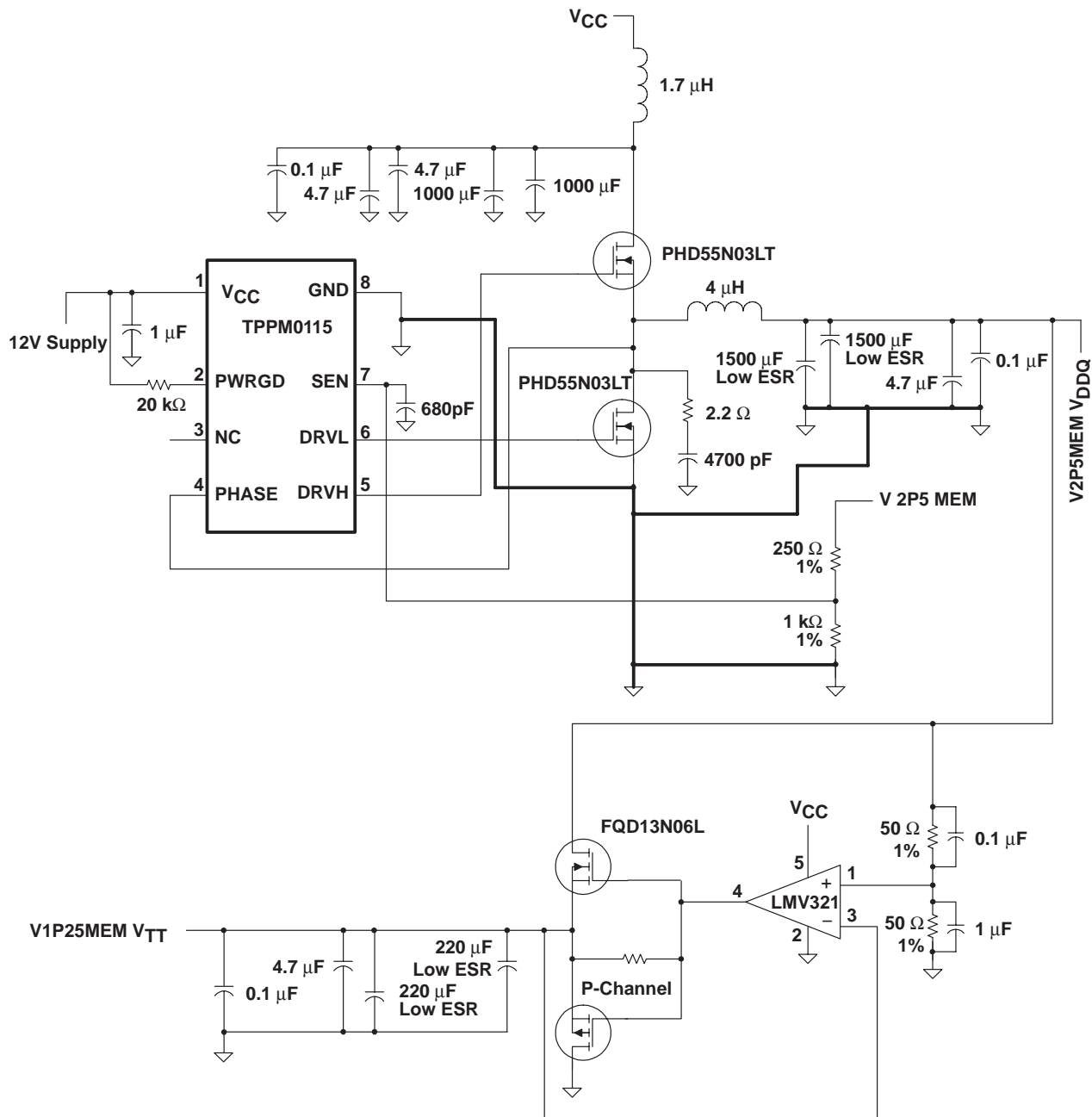

- NOTES: A. The heavy lines must be kept short and connected to the ground plane construction for efficient results.
B. The performance of the regulator depends on the proper selection of the external components for the application.

Figure 9. Application Schematic for DDR Memory V_{DDQ} and V_{TT} Supplies

APPLICATION INFORMATION

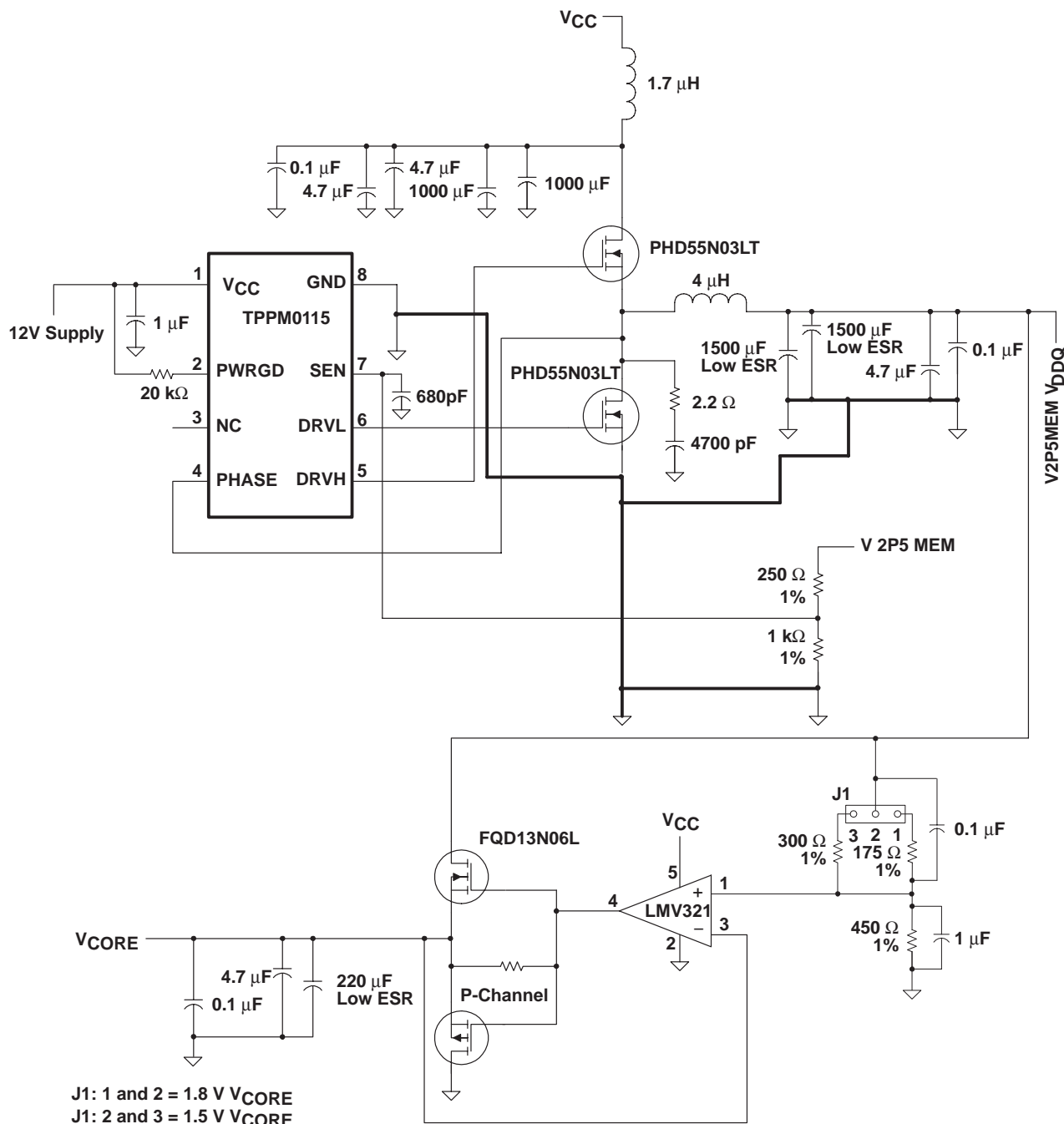

NOTES: A. The heavy lines must be kept short and connected to the ground plane construction for efficient results.
 B. The performance of the regulator depends on the proper selection of the external components for the application.

Figure 10. Application Schematic for RAMBUS Memory V_{DDQ} and V_{CORE} Supplies

TPPM0115 SWITCH MODE SYNCHRONOUS BUCK CONTROLLER

SLVS371A- MARCH 2001 - REVISED JUNE 2001

MECHANICAL DATA

D (R-PDSO-G**)

PLASTIC SMALL-OUTLINE PACKAGE

14 PINS SHOWN

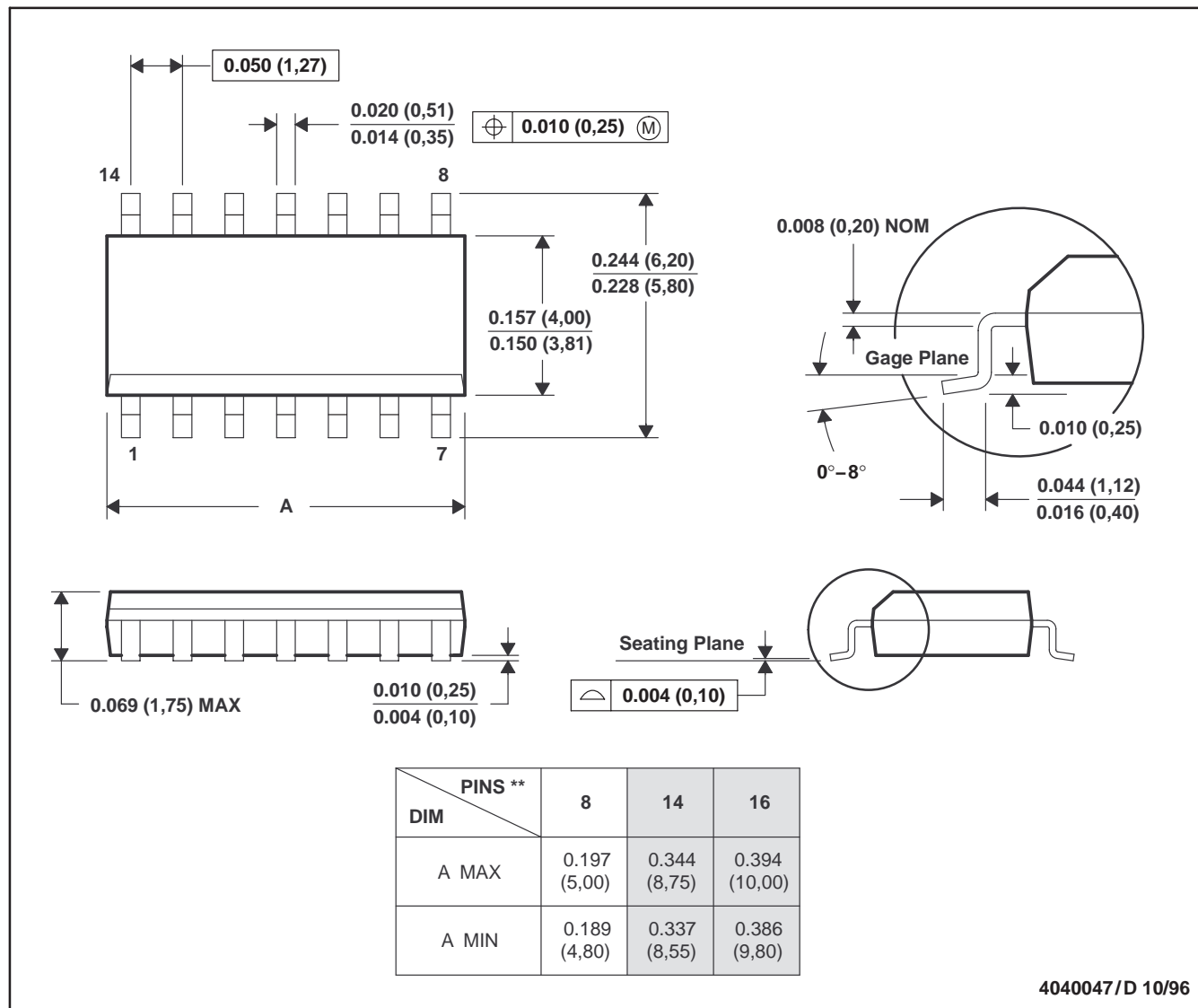

- NOTES: A. All linear dimensions are in inches (millimeters).
 B. This drawing is subject to change without notice.
 C. Body dimensions do not include mold flash or protrusion, not to exceed 0.006 (0,15).
 D. Falls within JEDEC MS-012

PACKAGING INFORMATION

Orderable Device	Status (1)	Package Type	Package Drawing	Pins	Package Qty	Eco Plan (2)	Lead finish/ Ball material (6)	MSL Peak Temp (3)	Op Temp (°C)	Device Marking (4/5)	Samples
TPPM0115D	ACTIVE	SOIC	D	8	75	RoHS & Green	NIPDAU	Level-1-260C-UNLIM	0 to 70	TP0115	Samples
TPPM0115DG4	ACTIVE	SOIC	D	8	75	RoHS & Green	NIPDAU	Level-1-260C-UNLIM	0 to 70	TP0115	Samples
TPPM0115DR	ACTIVE	SOIC	D	8	2500	RoHS & Green	NIPDAU	Level-1-260C-UNLIM	0 to 70	TP0115	Samples

(1) The marketing status values are defined as follows:

ACTIVE: Product device recommended for new designs.

LIFEBUY: TI has announced that the device will be discontinued, and a lifetime-buy period is in effect.

NRND: Not recommended for new designs. Device is in production to support existing customers, but TI does not recommend using this part in a new design.

PREVIEW: Device has been announced but is not in production. Samples may or may not be available.

OBsolete: TI has discontinued the production of the device.

(2) **RoHS:** TI defines "RoHS" to mean semiconductor products that are compliant with the current EU RoHS requirements for all 10 RoHS substances, including the requirement that RoHS substance do not exceed 0.1% by weight in homogeneous materials. Where designed to be soldered at high temperatures, "RoHS" products are suitable for use in specified lead-free processes. TI may reference these types of products as "Pb-Free".

RoHS Exempt: TI defines "RoHS Exempt" to mean products that contain lead but are compliant with EU RoHS pursuant to a specific EU RoHS exemption.

Green: TI defines "Green" to mean the content of Chlorine (Cl) and Bromine (Br) based flame retardants meet JS709B low halogen requirements of <=1000ppm threshold. Antimony trioxide based flame retardants must also meet the <=1000ppm threshold requirement.

(3) MSL, Peak Temp. - The Moisture Sensitivity Level rating according to the JEDEC industry standard classifications, and peak solder temperature.

(4) There may be additional marking, which relates to the logo, the lot trace code information, or the environmental category on the device.

(5) Multiple Device Markings will be inside parentheses. Only one Device Marking contained in parentheses and separated by a "~" will appear on a device. If a line is indented then it is a continuation of the previous line and the two combined represent the entire Device Marking for that device.

(6) Lead finish/Ball material - Orderable Devices may have multiple material finish options. Finish options are separated by a vertical ruled line. Lead finish/Ball material values may wrap to two lines if the finish value exceeds the maximum column width.

Important Information and Disclaimer: The information provided on this page represents TI's knowledge and belief as of the date that it is provided. TI bases its knowledge and belief on information provided by third parties, and makes no representation or warranty as to the accuracy of such information. Efforts are underway to better integrate information from third parties. TI has taken and continues to take reasonable steps to provide representative and accurate information but may not have conducted destructive testing or chemical analysis on incoming materials and chemicals. TI and TI suppliers consider certain information to be proprietary, and thus CAS numbers and other limited information may not be available for release.

In no event shall TI's liability arising out of such information exceed the total purchase price of the TI part(s) at issue in this document sold by TI to Customer on an annual basis.

TAPE AND REEL INFORMATION



QUADRANT ASSIGNMENTS FOR PIN 1 ORIENTATION IN TAPE



*All dimensions are nominal

Device	Package Type	Package Drawing	Pins	SPQ	Reel Diameter (mm)	Reel Width W1 (mm)	A0 (mm)	B0 (mm)	K0 (mm)	P1 (mm)	W (mm)	Pin1 Quadrant
TPPM0115DR	SOIC	D	8	2500	330.0	12.4	6.4	5.2	2.1	8.0	12.0	Q1

TAPE AND REEL BOX DIMENSIONS



*All dimensions are nominal

Device	Package Type	Package Drawing	Pins	SPQ	Length (mm)	Width (mm)	Height (mm)
TPPM0115DR	SOIC	D	8	2500	350.0	350.0	43.0

IMPORTANT NOTICE AND DISCLAIMER

TI PROVIDES TECHNICAL AND RELIABILITY DATA (INCLUDING DATASHEETS), DESIGN RESOURCES (INCLUDING REFERENCE DESIGNS), APPLICATION OR OTHER DESIGN ADVICE, WEB TOOLS, SAFETY INFORMATION, AND OTHER RESOURCES "AS IS" AND WITH ALL FAULTS, AND DISCLAIMS ALL WARRANTIES, EXPRESS AND IMPLIED, INCLUDING WITHOUT LIMITATION ANY IMPLIED WARRANTIES OF MERCHANTABILITY, FITNESS FOR A PARTICULAR PURPOSE OR NON-INFRINGEMENT OF THIRD PARTY INTELLECTUAL PROPERTY RIGHTS.

These resources are intended for skilled developers designing with TI products. You are solely responsible for (1) selecting the appropriate TI products for your application, (2) designing, validating and testing your application, and (3) ensuring your application meets applicable standards, and any other safety, security, or other requirements. These resources are subject to change without notice. TI grants you permission to use these resources only for development of an application that uses the TI products described in the resource. Other reproduction and display of these resources is prohibited. No license is granted to any other TI intellectual property right or to any third party intellectual property right. TI disclaims responsibility for, and you will fully indemnify TI and its representatives against, any claims, damages, costs, losses, and liabilities arising out of your use of these resources.

TI's products are provided subject to TI's Terms of Sale (<https://www.ti.com/legal/termsofsale.html>) or other applicable terms available either on [ti.com](https://www.ti.com) or provided in conjunction with such TI products. TI's provision of these resources does not expand or otherwise alter TI's applicable warranties or warranty disclaimers for TI products.

Mailing Address: Texas Instruments, Post Office Box 655303, Dallas, Texas 75265
Copyright © 2021, Texas Instruments Incorporated