

TPS3760 High Voltage Supervisor with Programmable Sense and Reset Delay Function

1 Features

- **Functional Safety-Capable**
 - Documentation available to aid functional safety system design
- Wide supply voltage range: 2.7 V to 65 V
- SENSE and RESET pins are 65 V graded
- Low quiescent current: 1 μ A (typical)
- Flexible and wide voltage threshold options [Table 12-1](#)
 - 2.7 V to 36 V (1.5% maximum accuracy)
 - 800 mV option (1% maximum accuracy)
- Built-in hysteresis (V_{HYS})
 - Percentage options: 2% to 13% (1% steps)
 - Fixed options: $V_{TH} < 8\text{ V} = 0.5\text{ V}, 1\text{ V}, 1.5\text{ V}, 2\text{ V}, 2.5\text{ V}$
- Programmable reset time delay
 - 10 nF = 12.8 ms, 10 μ F = 12.8 s
- Programmable sense time delay
 - 10 nF = 1.28 ms, 10 μ F = 1.28 s
- Manual Reset (\overline{MR}) feature
- Output reset latching feature
- Output topology: Open-Drain or Push-Pull

2 Applications

- Analog input module
- CPU (PLC controller)
- Servo drive control module
- Servo drive power stage module
- Servo drive functional safety module
- HVAL valve and actuator control

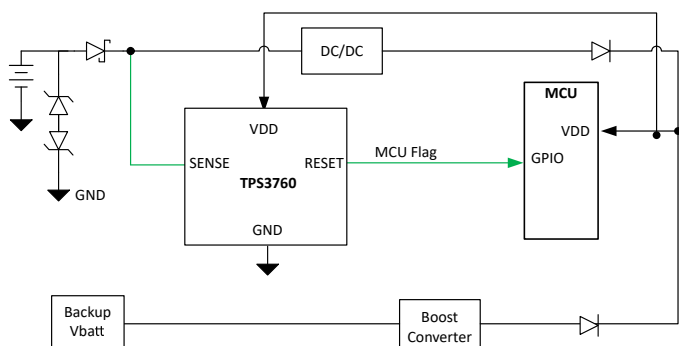

Typical Application Circuit

3 Description

The TPS3760 is a family of wide input range and low quiescent current window supervisors for fast detection of overvoltage (OV) or undervoltage (UV) conditions. The TPS3760 can be connected directly to and monitor 12 V / 24 V supply rails in a variety of industrial applications including factory automation, motor drives, building automation and others. Built-in hysteresis on the SENSE pins prevents false reset signals when monitoring a supply voltage rail.

The separate VDD and SENSE pins allow redundancy sought by high-reliability systems. SENSE is decoupled from VDD and can monitor higher and lower voltages than VDD. Optional use of external resistors are supported by the high impedance input of the SENSE pins. CTSx and CTRx pins allow delay adjustability on the rising and falling edges of the RESET signals. Also, CTSx functions as a debouncer by ignoring voltage glitches on the monitored voltage rails; CTRx operates as a manual reset (\overline{MR}) that can be used to force a system reset.

The TPS3760 is available in a 4.1-mm \times 1.9-mm SOT 14-pin package. TPS3760 operates over -40°C to $+125^{\circ}\text{C}$ T_A .

Device Information

PART NUMBER	PACKAGE ⁽¹⁾	BODY SIZE (NOM)
TPS3760	SOT-23 (14) (DYY)	4.1 mm \times 1.9 mm

- (1) For package details, see the mechanical drawing addendum at the end of the data sheet.

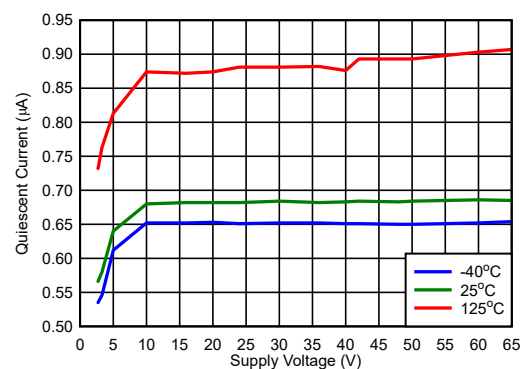

Typical I_{DD} vs V_{DD}



Table of Contents

1 Features	1	9 Application and Implementation	28
2 Applications	1	9.1 Application Information.....	28
3 Description	1	9.2 Adjustable Voltage Thresholds.....	28
4 Revision History	2	9.3 Typical Application.....	29
5 Device Comparison	3	10 Power Supply Recommendations	32
6 Pin Configuration and Functions	4	10.1 Power Dissipation and Device Operation.....	32
7 Specifications	6	11 Layout	33
7.1 Absolute Maximum Ratings.....	6	11.1 Layout Guidelines.....	33
7.2 ESD Ratings.....	6	11.2 Layout Example.....	33
7.3 Recommended Operating Conditions.....	6	11.3 Creepage Distance.....	34
7.4 Thermal Information.....	6	12 Device and Documentation Support	35
7.5 Electrical Characteristics.....	7	12.1 Device Nomenclature.....	35
7.6 Timing Requirements.....	9	12.2 Receiving Notification of Documentation Updates..	36
7.7 Timing Diagrams.....	10	12.3 Support Resources.....	36
7.8 Typical Characteristics.....	13	12.4 Trademarks.....	36
8 Detailed Description	17	12.5 Electrostatic Discharge Caution.....	36
8.1 Overview.....	17	12.6 Glossary.....	36
8.2 Functional Block Diagram.....	17	13 Mechanical, Packaging, and Orderable	
8.3 Feature Description.....	18	Information	36
8.4 Device Functional Modes.....	27		

4 Revision History

NOTE: Page numbers for previous revisions may differ from page numbers in the current version.

Changes from Revision * (March 2022) to Revision A (September 2023)	Page
• Added Latch nomenclature.....	3
• Removed DSK pinout description.....	4
• Added CTS and CTR timing plots.....	13
• Added Reset latch mode information.....	26
• Fixed nomenclature 08 to 01.....	35

5 Device Comparison

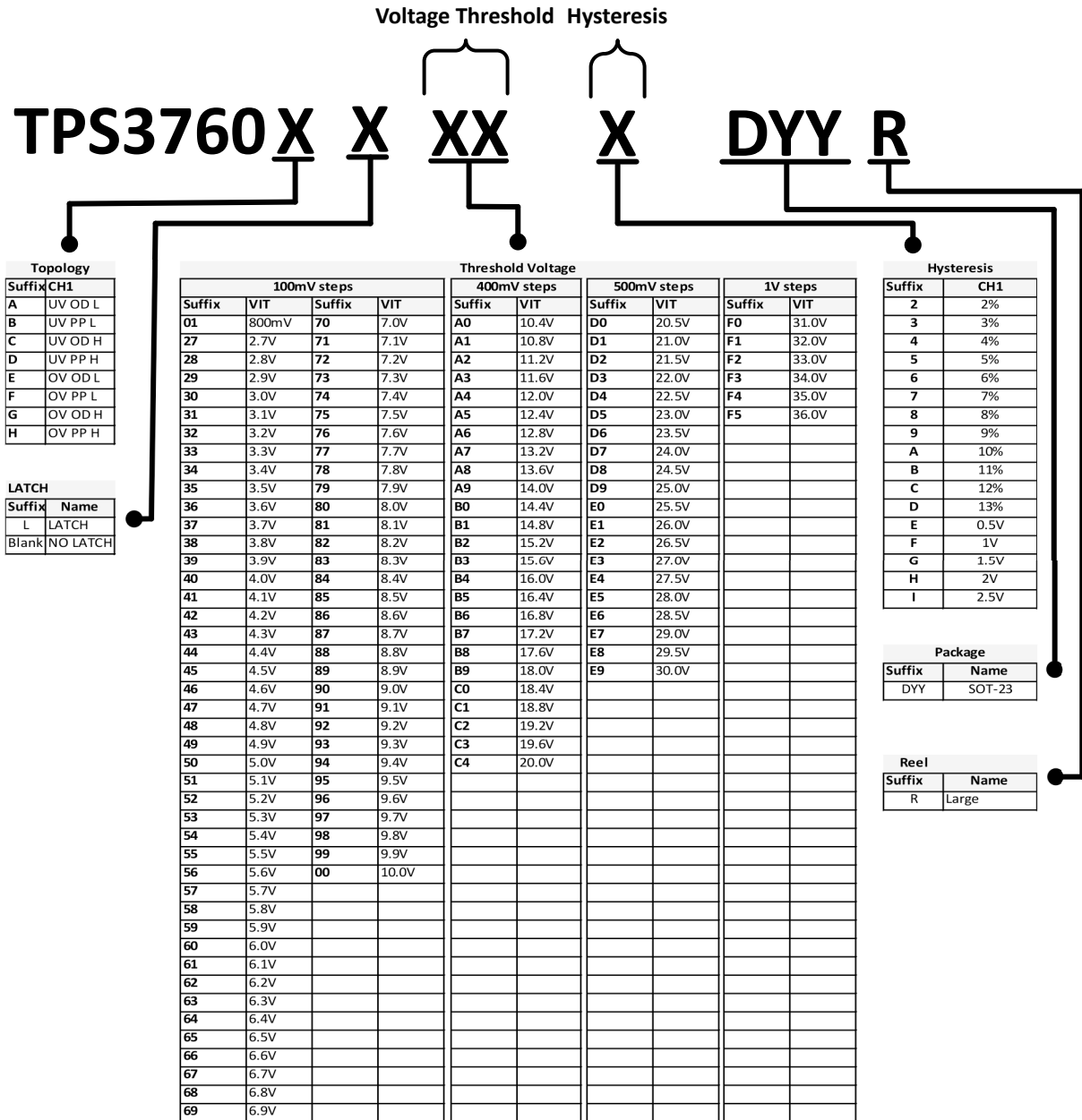

1. Sense logic: OV = overvoltage; UV = undervoltage
2. Reset topology: PP = Push-Pull; OD = Open-Drain
3. Reset logic: L = Active-Low; H = Active-High
4. A to I hysteresis options are only available for 2.9 V to 8V threshold options
5. Suffix 01 with VIT of 800mV corresponds to the adjustable variant, does not have internal voltage divider

6 Pin Configuration and Functions

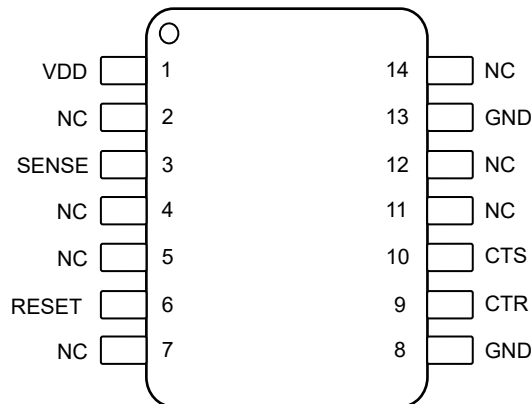

**Figure 6-1. DYY Package,
14-Pin SOT-23,
TPS3760 (Top View)**

Table 6-1. Pin Functions

PIN NAME	SOT23 (DYY) NO.	I/O	DESCRIPTION
VDD	1	I	Input Supply Voltage: Bypass with a 0.1 μ F capacitor to GND.
SENSE	3	I	Sense Voltage: The voltage monitored by this pin is compared to the internal voltage threshold, V_{th} , that is determined by an internal voltage divider for fixed variants or an external voltage divider for adjustable variants. When the SENSE pin detects a fault, $\overline{\text{RESET}}/\text{RESET}$ asserts after the sense time delay, set by CTS. When the voltage on the SENSE pin transitions back past V_{th} and hysteresis, V_{HYS} , $\overline{\text{RESET}}/\text{RESET}$ deasserts after the reset time delay, set by CTR. For noisy applications, placing a 10 nF to 100 nF ceramic capacitor close to this pin may be needed for optimum performance. Sensing Topology: Overvoltage (OV) or Undervoltage (UV)
$\overline{\text{RESET}}/\text{RESET}$	6	O	Output Reset Signal: See Device Comparison for output topology options. $\overline{\text{RESET}}/\text{RESET}$ asserts when SENSE crosses the voltage threshold after the sense time delay, set by CTS. $\overline{\text{RESET}}/\text{RESET}$ remains asserted for the reset time delay period after SENSE transitions out of a fault condition. For active low open-drain reset output, an external pullup resistor is required. Do not place external pullup resistors on push-pull outputs. Output topology: Open Drain or Push Pull, Active Low or Active High
CTS / $\overline{\text{LATCH}}$	10	O	SENSE Time Delay: Capacitor programmable sense delay: CTS pin offers a user-adjustable sense delay time when asserting a reset condition. Connecting this pin to a ground-referenced capacitor sets the $\overline{\text{RESET}}/\text{RESET}$ delay time to assert. LATCH: CTS functionality is disabled in latch capable devices. When latch mode is activated, $\overline{\text{RESET}}/\text{RESET}$ will not de-assert even if the fault is cleared. To activate latch mode, the $\overline{\text{LATCH}}$ pin has to be driven low, to at least 1.4V. It is recommended to have a 10k Ω pull-down to ground. To deactivate latch mode, a 2.1V or greater for 3 μ s has to be applied to the $\overline{\text{LATCH}}$ pin while SENSE pin is not detecting a fault. $\overline{\text{RESET}}/\text{RESET}$ will de-assert with delay t_{ctr} starting on the rising edge of the deactivating signal.
CTR / $\overline{\text{MR}}$	9	-	RESET Time Delay: User-programmable reset time delay for $\overline{\text{RESET}}/\text{RESET}$. Connect an external capacitor for adjustable time delay or leave the pin floating for the shortest delay. Manual Reset: If this pin is driven low, the $\overline{\text{RESET}}/\text{RESET}$ output will reset and become asserted. The pin can be left floating or be connected to a capacitor. This pin should not be driven high.
GND	8, 13	-	Ground. All GND pins must be electrically connected to the board ground.

Table 6-1. Pin Functions (continued)

PIN	SOT23 (DYY)	I/O	DESCRIPTION
NAME	NO.		
NC	2, 4, 5, 7, 11,12, 14	-	NC stands for "No Connect." The pins are to be left floating.

7 Specifications

7.1 Absolute Maximum Ratings

over operating free-air temperature range, unless otherwise noted ⁽¹⁾

		MIN	MAX	UNIT
Voltage	V _{DD} , V _{SENSE} , V _{RESET} , V _{RESET}	-0.3	70	V
Voltage	V _{CTS} , V _{CTR}	-0.3	6	V
Current	I _{RESET} , I _{RESET}		10	mA
Temperature ⁽²⁾	Operating junction temperature, T _J	-40	150	°C
Temperature ⁽²⁾	Operating Ambient temperature, T _A	-40	150	°C
Temperature ⁽²⁾	Storage, T _{stg}	-65	150	°C

- (1) Stresses beyond those listed under Absolute Maximum Ratings may cause permanent damage to the device. These are stress ratings only, which do not imply functional operation of the device at these or any other conditions beyond those indicated under Recommended Operating Conditions. Exposure to absolute-maximum-rated conditions for extended periods may affect device reliability.
- (2) As a result of the low dissipated power in this device, it is assumed that T_J = T_A.

7.2 ESD Ratings

		VALUE	UNIT
V _(ESD)	Electrostatic discharge	Human body model (HBM), per ANSI/ESDA/JEDEC JS-002 ⁽¹⁾	±2000
		Charged device model (CDM), per JEDEC specification JESD22-C101 ⁽²⁾	±750

- (1) JEDEC document JEP155 states that 500-V HBM allows safe manufacturing with a standard ESD control process.
- (2) JEDEC document JEP157 states that 250-V CDM allows safe manufacturing with a standard ESD control process.

7.3 Recommended Operating Conditions

over operating free-air temperature range (unless otherwise noted)

		MIN	NOM	MAX	UNIT
Voltage	V _{DD}	2.7		65	V
Voltage	V _{SENSE} , V _{RESET} , V _{RESET}	0		65	V
Voltage	V _{CTS} , V _{CTR}	0		5.5	V
Current	I _{RESET} , I _{RESET}	0		±5	mA
T _J	Junction temperature (free air temperature)	-40		125	°C

7.4 Thermal Information

THERMAL METRIC ⁽¹⁾		TPS3760		UNIT
		DYY		
		14-PIN		
R _{θJA}	Junction-to-ambient thermal resistance	131.5		°C/W
R _{θJC(top)}	Junction-to-case (top) thermal resistance	61.1		°C/W
R _{θJB}	Junction-to-board thermal resistance	56.6		°C/W
Ψ _{JT}	Junction-to-top characterization parameter	3.4		°C/W
Ψ _{JB}	Junction-to-board characterization parameter	56.5		°C/W
R _{θJC(bot)}	Junction-to-case (bottom) thermal resistance	N/A		°C/W

- (1) For more information about traditional and new thermal metrics, see the [Semiconductor and IC Package Thermal Metrics](#) application report.

7.5 Electrical Characteristics

At $V_{DD(MIN)} \leq V_{DD} \leq V_{DD(MAX)}$, $CTR/\overline{MR} = CTS = \text{open}$, output reset pull-up resistor $R_{PU} = 10 \text{ k}\Omega$, voltage $V_{PU} = 5.5 \text{ V}$, and load $C_{LOAD} = 10 \text{ pF}$. The operating free-air temperature range $T_A = -40^\circ\text{C}$ to 125°C , unless otherwise noted. Typical values are at $T_A = 25^\circ\text{C}$ and $V_{DD} = 16 \text{ V}$ and $V_{IT} = 6.5 \text{ V}$ (V_{IT} refers to V_{ITN} or V_{ITP}).

PARAMETER	TEST CONDITIONS	MIN	TYP	MAX	UNIT
VDD					
V_{DD}	Supply Voltage	2.7		65	V
UVLO ⁽¹⁾	Under Voltage Lockout	V_{DD} Falling below $V_{DD(MIN)}$		2.7	V
V_{POR}	Power on Reset Voltage ⁽²⁾ RESET, Active Low (Open-Drain, Push-Pull)	$V_{OL(MAX)} = 300 \text{ mV}$ $I_{OUT(SINK)} = 15 \mu\text{A}$		1.4	V
V_{POR}	Power on Reset Voltage ⁽²⁾ RESET, Active High (Push-Pull)	$V_{OH(MIN)} = 0.8 \times V_{DD}$ $I_{OUT(SOURCE)} = 15 \mu\text{A}$		1.4	V
I_{DD}	Supply current into VDD pin	$V_{IT} = 800 \text{ mV}$ $V_{DD(MIN)} \leq V_{DD} \leq V_{DD(MAX)}$		1	μA
		$V_{IT} = 2.7 \text{ V to } 36 \text{ V}$ $V_{DD(MIN)} \leq V_{DD} \leq V_{DD(MAX)}$		1	μA
SENSE (Input)					
I_{SENSE}	Input current	$V_{IT} = 800 \text{ mV}$		100	nA
I_{SENSE}	Input current	$V_{IT} < 10 \text{ V}$		0.8	μA
I_{SENSE}	Input current	$10 \text{ V} < V_{IT} < 26 \text{ V}$		1.2	μA
I_{SENSE}	Input current	$V_{IT} > 26 \text{ V}$		2	μA
V_{ITN}	Input Threshold Negative (Undervoltage)	$V_{IT} = 2.7 \text{ V to } 36 \text{ V}$		-1.5	%
		$V_{IT} = 800 \text{ mV}$ ⁽³⁾		0.792	0.800
V_{ITP}	Input Threshold Positive (Overvoltage)	$V_{IT} = 2.7 \text{ V to } 36 \text{ V}$		-1.5	%
		$V_{IT} = 800 \text{ mV}$ ⁽³⁾		0.792	0.800
V_{HYS}	Hysteresis Accuracy ⁽⁴⁾	$V_{IT} = 0.8 \text{ V and } 2.7 \text{ V to } 36 \text{ V}$ V_{HYS} Range = 2% to 13% (1% step)		-1.5	%
		$V_{IT} = 2.7 \text{ V to } 8 \text{ V}$ $V_{HYS} = 0.5 \text{ V, } 1 \text{ V, } 1.5 \text{ V, } 2 \text{ V, } 2.5 \text{ V}$ ($V_{ITP} - V_{HYS} \geq 2.4 \text{ V, OV Only}$)		-1.5	1.5
RESET (Output)					
$I_{lkg(OD)}$	Open-Drain leakage	$V_{RESET} = 5.5 \text{ V}$ $V_{ITN} < V_{SENSE} < V_{ITP}$		300	nA
		$V_{RESET} = 65 \text{ V}$ $V_{ITN} < V_{SENSE} < V_{ITP}$		300	nA
V_{OL} ⁽⁵⁾	Low level output voltage	$2.7 \text{ V} \leq V_{DD} \leq 65 \text{ V}$ $I_{RESET} = 5 \text{ mA}$		300	mV
V_{OH_DO}	High level output voltage dropout ($V_{DD} - V_{OH} = V_{OH_DO}$) (Push-Pull only)	$2.7 \text{ V} \leq V_{DD} \leq 65 \text{ V}$ $I_{RESET} = 500 \mu\text{A}$		100	mV
V_{OH} ⁽⁵⁾	High level output voltage (Push-Pull only)	$2.7 \text{ V} \leq V_{DD} \leq 65 \text{ V}$ $I_{RESET} = 5 \text{ mA}$		$0.8V_{DD}$	V

7.5 Electrical Characteristics (continued)

At $V_{DD(MIN)} \leq V_{DD} \leq V_{DD(MAX)}$, $CTR/\overline{MR} = CTS = \text{open}$, output reset pull-up resistor $R_{PU} = 10 \text{ k}\Omega$, voltage $V_{PU} = 5.5 \text{ V}$, and load $C_{LOAD} = 10 \text{ pF}$. The operating free-air temperature range $T_A = -40^\circ\text{C}$ to 125°C , unless otherwise noted. Typical values are at $T_A = 25^\circ\text{C}$ and $V_{DD} = 16 \text{ V}$ and $V_{IT} = 6.5 \text{ V}$ (V_{IT} refers to V_{ITN} or V_{ITP}).

PARAMETER		TEST CONDITIONS	MIN	TYP	MAX	UNIT
Capacitor Timing (CTS, CTR)						
R_{CTR}	Internal resistance (CTR / \overline{MR})		877	1000	1147	Kohms
R_{CTS}	Internal resistance (C_{TS})		88	100	122	Kohms
Manual Reset (\overline{MR})						
$V_{\overline{MR_IH}}$	CTR / \overline{MR} pin logic high input	$V_{DD} = 2.7 \text{ V}$	2200			mV
$V_{\overline{MR_IH}}$	CTR / \overline{MR} pin logic high input	$V_{DD} = 65 \text{ V}$	2500			mV
$V_{\overline{MR_IL}}$	CTR / \overline{MR} pin logic low input	$V_{DD} = 2.7 \text{ V}$			1300	mV
$V_{\overline{MR_IL}}$	CTR / \overline{MR} pin logic low input	$V_{DD} = 65 \text{ V}$			1300	mV

- When V_{DD} voltage falls below UVLO, reset is asserted for Output. V_{DD} slew rate $\leq 100 \text{ mV} / \mu\text{s}$
- V_{POR} is the minimum V_{DD} voltage for a controlled output state. Below V_{POR} , the output cannot be determined. $V_{DD} \text{ dv/dt} \leq 100 \text{ mV}/\mu\text{s}$
- For adjustable voltage guidelines and resistor selection refer to **Adjustable Voltage Thresholds** in **Application and Implementation section**
- Hysteresis is with respect to V_{ITP} and V_{ITN} voltage threshold. V_{ITP} has negative hysteresis and V_{ITN} has positive hysteresis.
- For V_{OH} and V_{OL} relation to output variants refer to **Timing Figures after the Timing Requirement Table**

7.6 Timing Requirements

At $V_{DD(MIN)} \leq V_{DD} \leq V_{DD(MAX)}$, $CTR/\overline{MR} = CTS = \text{open}$ (1), output reset pull-up resistor $R_{PU} = 10 \text{ k}\Omega$, voltage $V_{PU} = 5.5\text{V}$, and $C_{LOAD} = 10 \text{ pF}$. V_{DD} and $SENSE$ slew rate = $1\text{V} / \mu\text{s}$. The operating free-air temperature range $T_A = -40^\circ\text{C}$ to 125°C , unless otherwise noted. Typical values are at $T_A = 25^\circ\text{C}$ and $V_{DD} = 16 \text{ V}$ and $V_{IT} = 6.5 \text{ V}$ (V_{IT} refers to either V_{ITN} or V_{ITP}).

PARAMETER	TEST CONDITIONS	MIN	TYP	MAX	UNIT	
Common timing parameters						
t_{CTR}	Reset release time delay (CTR/MR) (2)	$V_{IT} = 2.7 \text{ V to } 36 \text{ V}$ $C_{CTR} = \text{Open}$ 20% Overdrive from Hysteresis			100	μs
		$V_{IT} = 800 \text{ mV}$ $C_{CTR} = \text{Open}$ 20% Overdrive from Hysteresis			40	μs
t_{CTS}	Sense detect time delay (CTS) (3)	$V_{IT} = 2.7 \text{ V to } 36 \text{ V}$ $C_{CTS} = \text{Open}$ 20% Overdrive from V_{IT}		34	90	μs
		$V_{IT} = 800 \text{ mV}$ $C_{CTS} = \text{Open}$ 20% Overdrive from V_{IT}		8	17	μs
t_{SD}	Startup Delay (4)	$C_{CTR/\overline{MR}} = \text{Open}$			2	ms

- (1) C_{CTR} = Reset delay channel
 C_{CTS} = Sense delay channel
- (2) **CTR Reset detect time delay:**
Overvoltage active-LOW output is measure from $V_{ITP - HYS}$ to V_{OH}
Undervoltage active-LOW output is measure from $V_{ITN + HYS}$ to V_{OH}
Overvoltage active-HIGH output is measure from $V_{ITP - HYS}$ to V_{OL}
Undervoltage active-HIGH output is measure from $V_{ITN + HYS}$ to V_{OL}
- (3) **CTS Sense detect time delay:**
Active-low output is measure from V_{IT} to V_{OL} (or V_{Pullup})
Active-high output is measured from V_{IT} to V_{OH}
 V_{IT} refers to either V_{ITN} or V_{ITP}
- (4) During the power-on sequence, V_{DD} must be at or above $V_{DD(MIN)}$ for at least t_{SD} before the output is in the correct state based on V_{SENSE} .
 t_{SD} time includes the propagation delay ($C_{CTR} = \text{Open}$). Capacitor on C_{CTR} will add time to t_{SD} .

7.7 Timing Diagrams

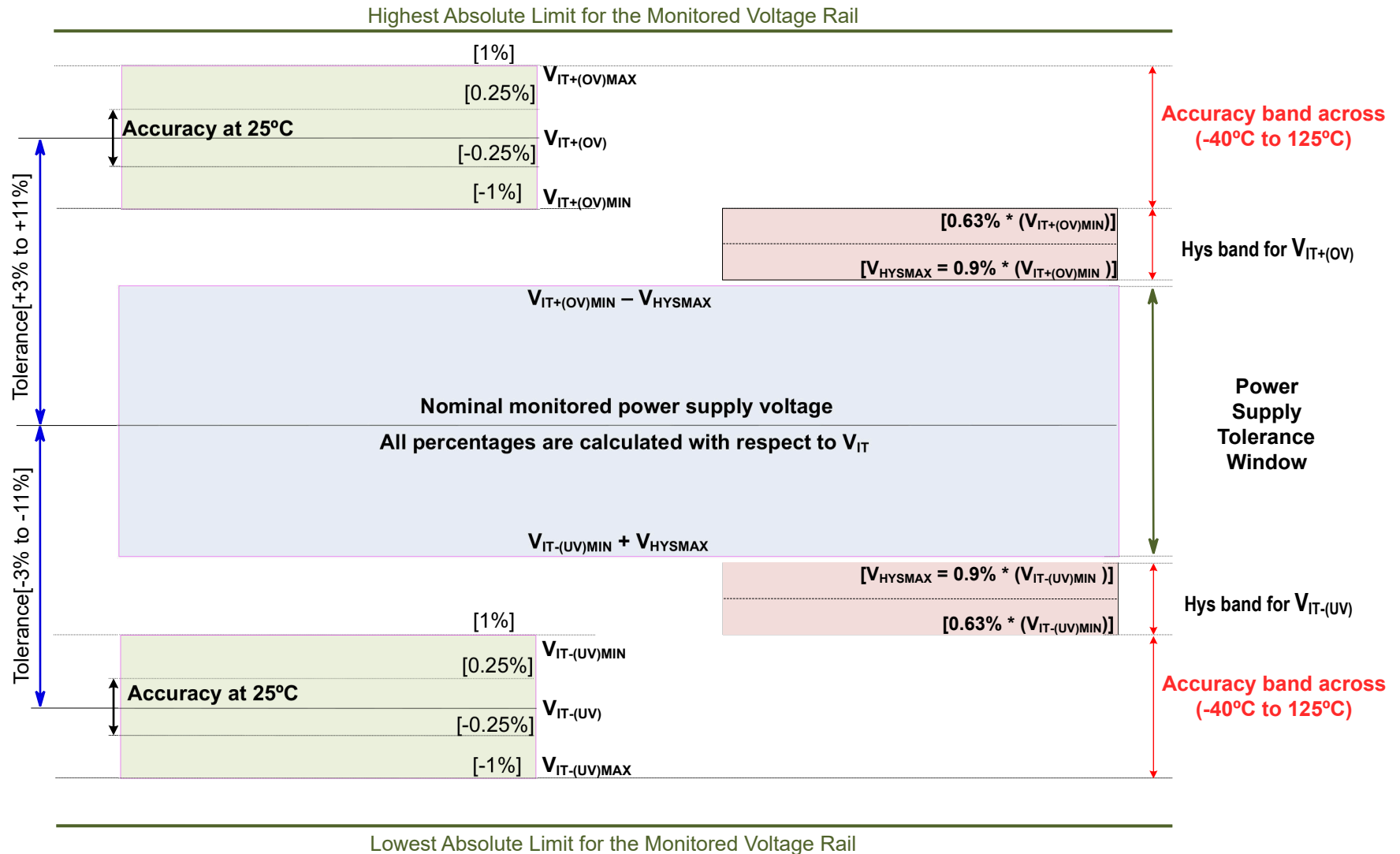
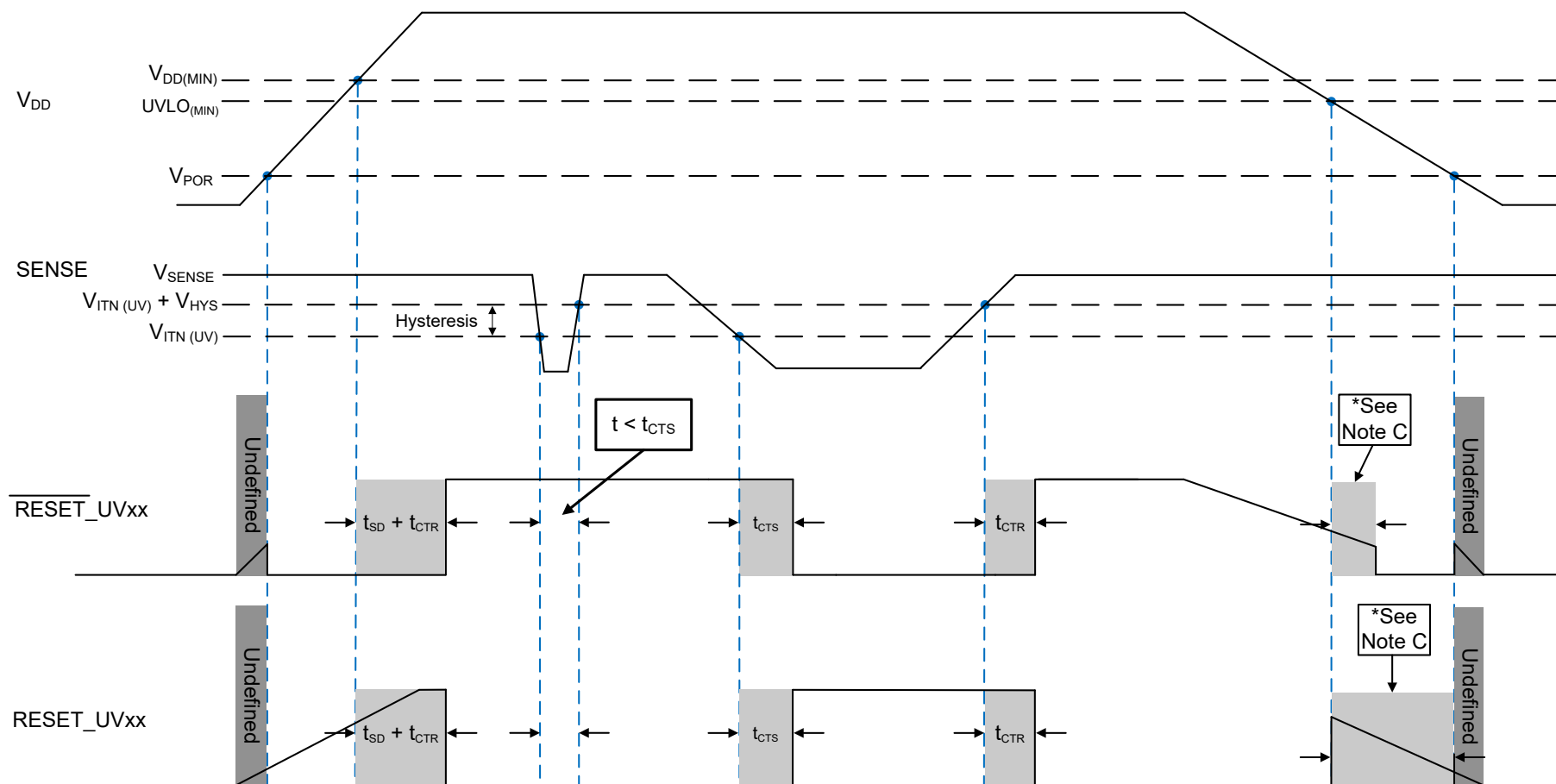
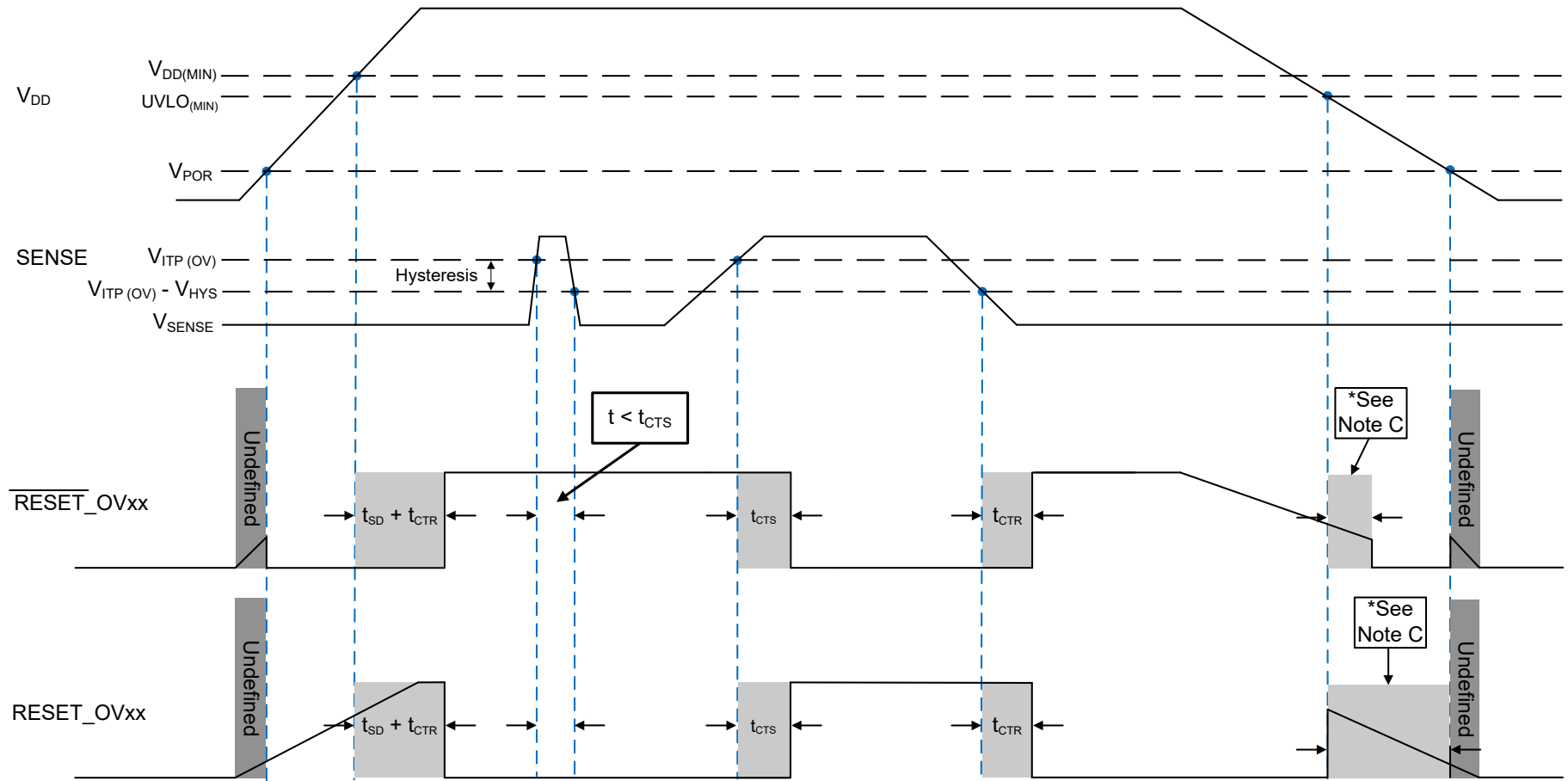

Figure 7-1. Voltage Threshold and Hysteresis Accuracy



- For open-drain output option, the timing diagram assumes the $\overline{\text{RESET_UVOD}}$ / $\overline{\text{RESET_UVOD}}$ pin is connected via an external pull-up resistor to VDD.
- Be advised that Figure 7-2 shows the VDD falling slew rate is slow or the VDD decay time is much larger than the propagation detect delay (t_{CTR}) time.
- $\overline{\text{RESET_UVxx}}$ / $\overline{\text{RESET_UVxx}}$ is asserted when VDD goes below the UVLO_(MIN) threshold after the time delay, t_{CTR} , is reached.

Figure 7-2. SENSE Undervoltage (UV) Timing Diagram



- A. For open-drain output option, the timing diagram assumes the $\overline{\text{RESET_OVOD}}$ / RESET_OVOD pin is connected via an external pull-up resistor to V_{DD}.
- B. Be advised that Figure 7-3 shows the V_{DD} falling slew rate is slow or the V_{DD} decay time is much larger than the propagation detect delay (t_{CTR}) time.
- C. $\overline{\text{RESET_OVxx}}$ / RESET_OVxx is asserted when V_{DD} goes below the UVLO_(MIN) threshold after the time delay, t_{CTR}, is reached.

Figure 7-3. SENSE Overvoltage (OV) Timing Diagram

7.8 Typical Characteristics

Typical characteristics show the typical performance of the device. Test conditions are $T_A = 25^\circ\text{C}$, $R_{PU} = 100\text{ k}\Omega$, $C_{Load} = 50\text{ pF}$, unless otherwise noted.

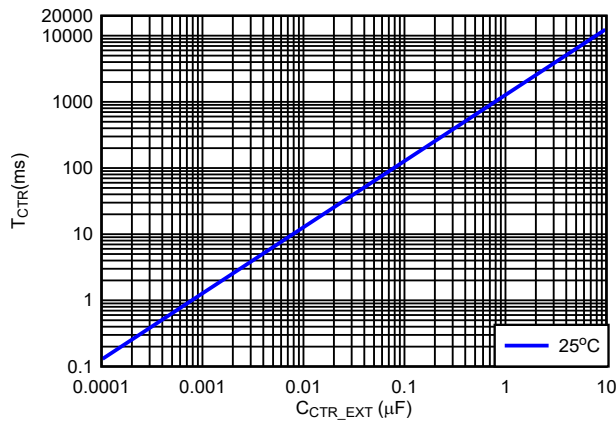

Figure 7-4. T_{CTR} vs C_{CTR}

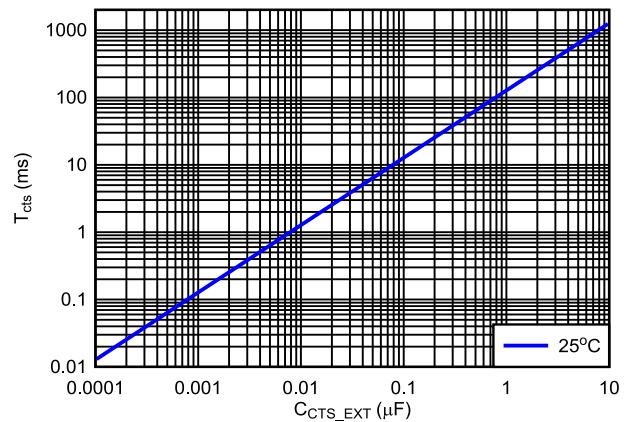
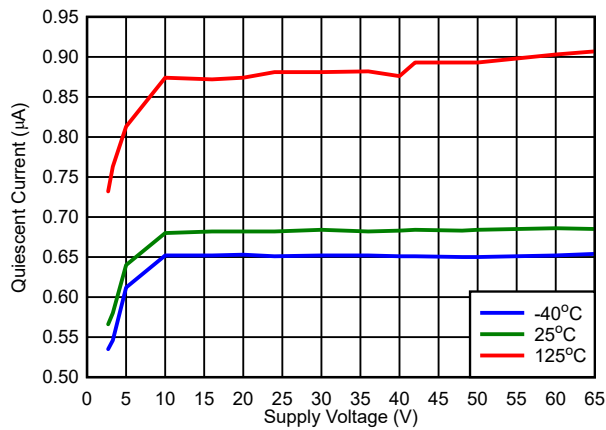
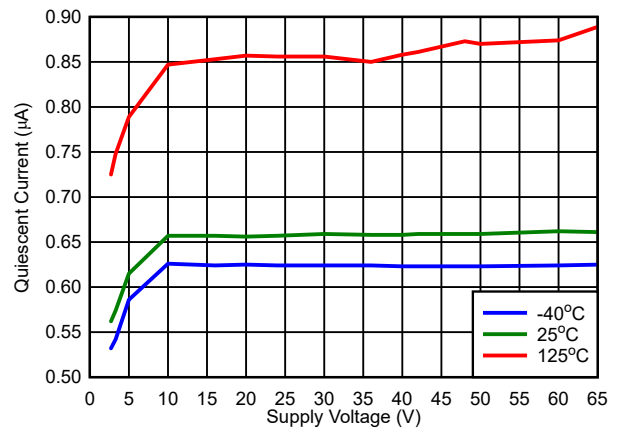

Figure 7-5. T_{CTS} vs C_{CTS}



$\overline{\text{RESET}} = \text{High}$, $V_{IT} = 2.7\text{ V}$

Figure 7-6. V_{DD} vs I_{DD} ($\overline{\text{RESET}} = \text{High}$, $V_{IT} = 2.7\text{ V}$)



$\overline{\text{RESET}} = \text{Low}$, $V_{IT} = 2.7\text{ V}$

Figure 7-7. V_{DD} vs I_{DD} ($\overline{\text{RESET}} = \text{Low}$, $V_{IT} = 2.7\text{ V}$)

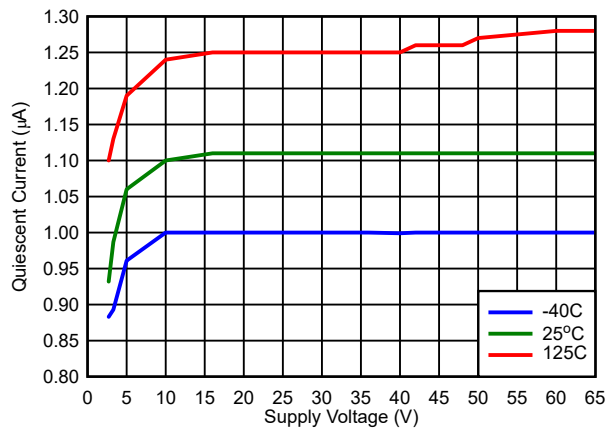

$\overline{\text{RESET}} = \text{High}$, $V_{IT} = 0.8\text{ V}$

Figure 7-8. V_{DD} vs I_{DD} ($\overline{\text{RESET}} = \text{High}$, $V_{IT} = 0.8\text{ V}$)

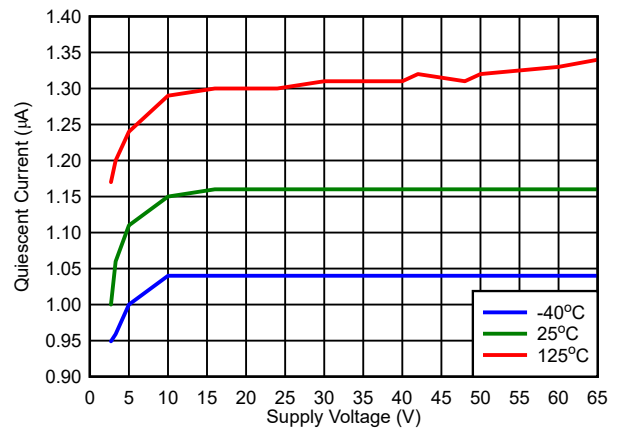

$\overline{\text{RESET}} = \text{Low}$, $V_{IT} = 0.8\text{ V}$

Figure 7-9. V_{DD} vs I_{DD} ($\overline{\text{RESET}} = \text{Low}$, $V_{IT} = 0.8\text{ V}$)

7.8 Typical Characteristics (continued)

Typical characteristics show the typical performance of the device. Test conditions are $T_A = 25^\circ\text{C}$, $R_{PU} = 100\text{ k}\Omega$, $C_{Load} = 50\text{ pF}$, unless otherwise noted.

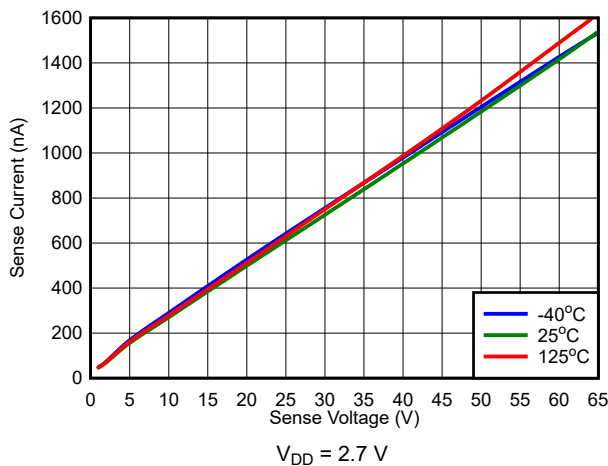

Figure 7-10. V_{SENSE} vs I_{SENSE}

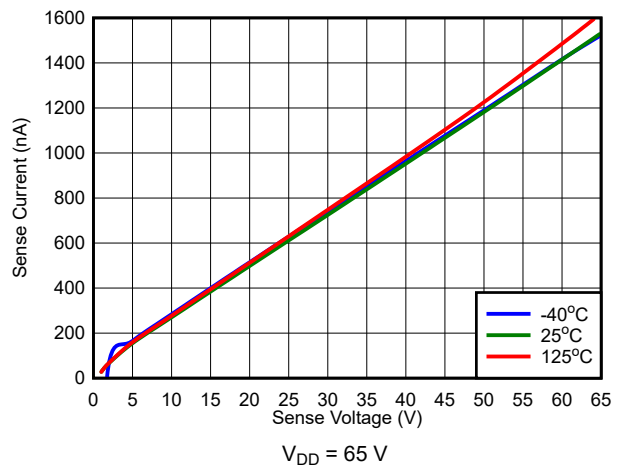

Figure 7-11. V_{SENSE} vs I_{SENSE}

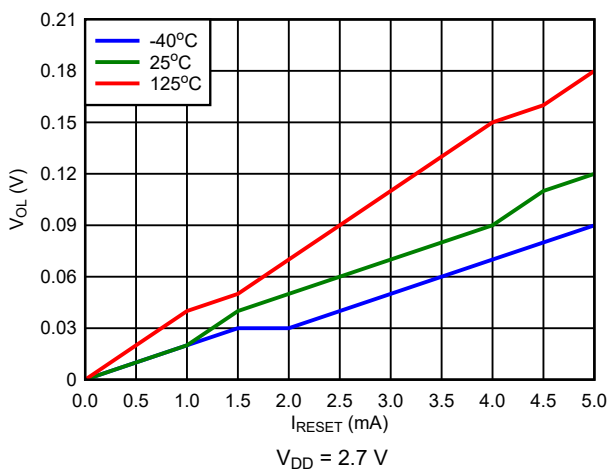

Figure 7-12. Open-Drain Active Low V_{OL} vs I_{RESET}

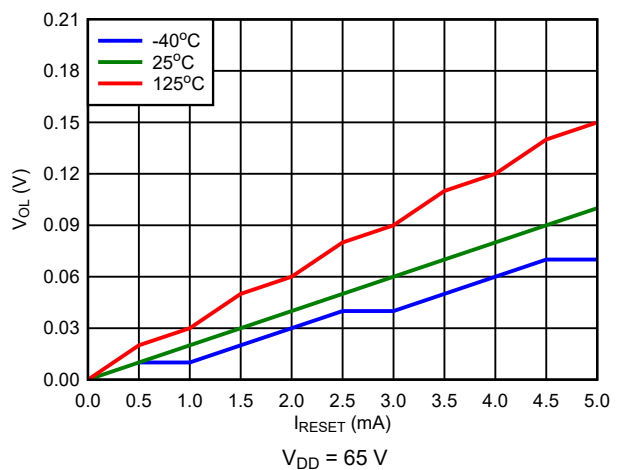

Figure 7-13. Open-Drain Active Low V_{OL} vs I_{RESET}

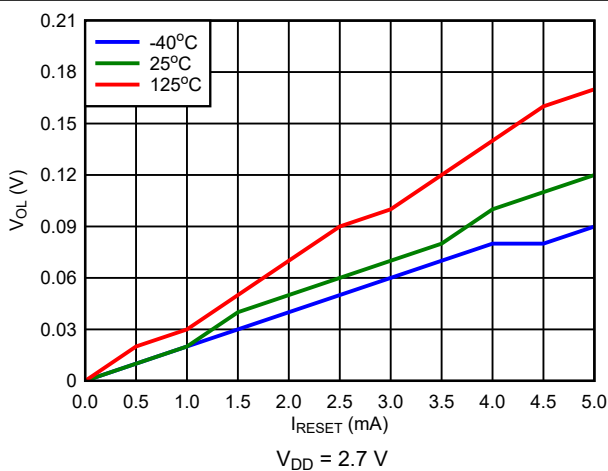

Figure 7-14. Open-Drain Active High V_{OL} vs I_{RESET}

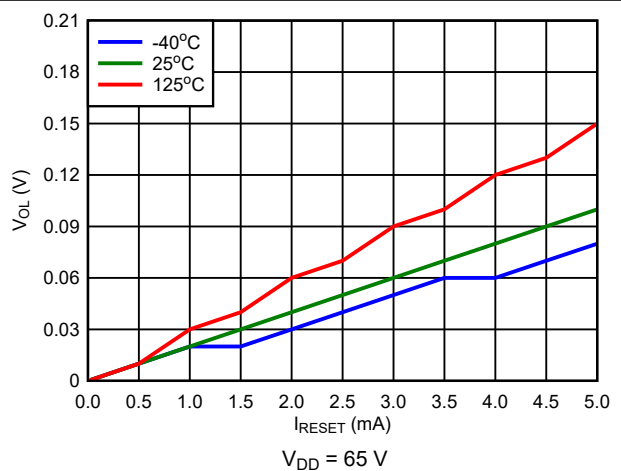

Figure 7-15. Open-Drain Active High V_{OL} vs I_{RESET}

7.8 Typical Characteristics (continued)

Typical characteristics show the typical performance of the device. Test conditions are $T_A = 25^\circ\text{C}$, $R_{PU} = 100\text{ k}\Omega$, $C_{Load} = 50\text{ pF}$, unless otherwise noted.

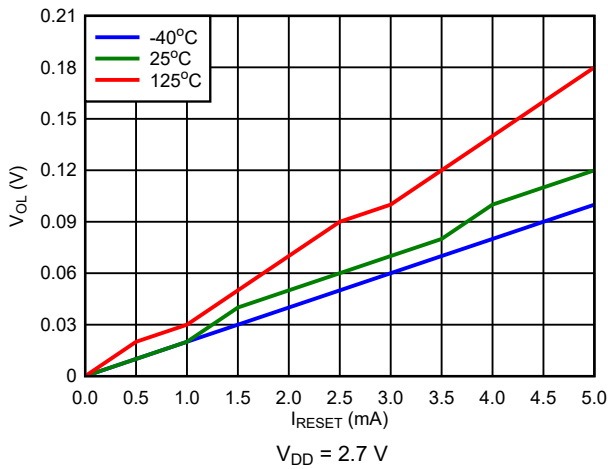

Figure 7-16. Push-Pull Active High V_{OL} vs I_{RESET}

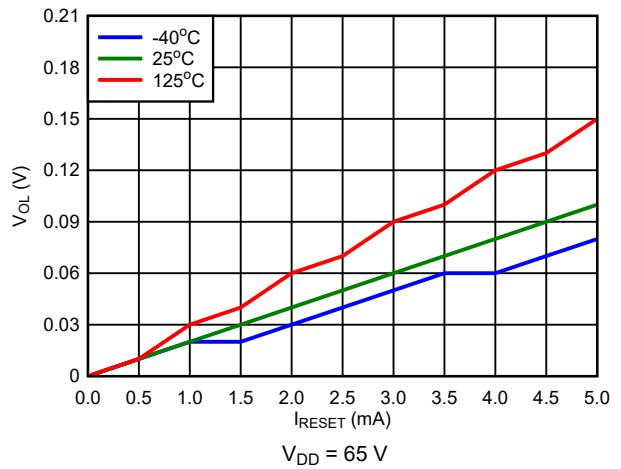

Figure 7-17. Push-Pull Active High V_{OL} vs I_{RESET}

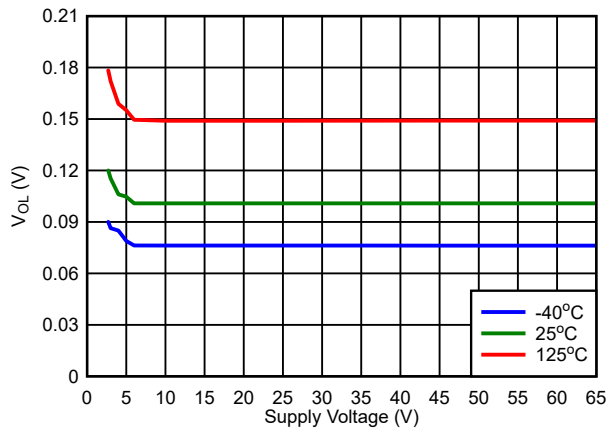

Figure 7-18. Open-Drain Active Low V_{OL} vs V_{DD}

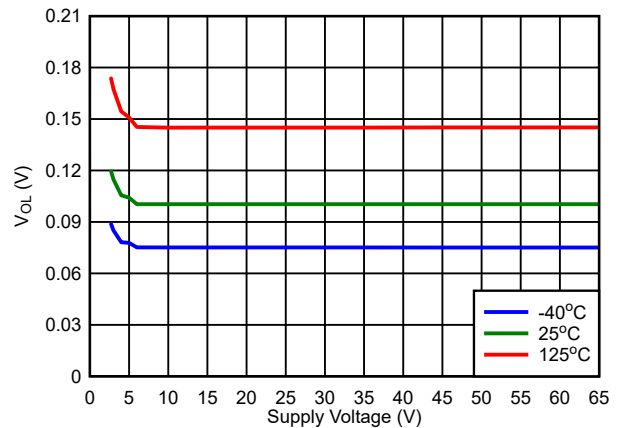

Figure 7-19. Open-Drain Active High V_{OL} vs V_{DD}

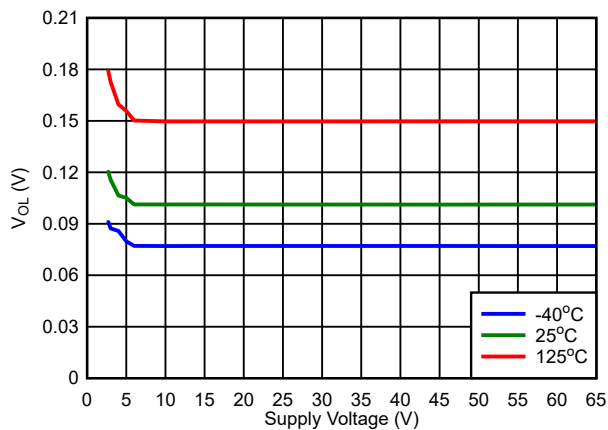

Figure 7-20. Push-Pull Active Low V_{OL} vs V_{DD}

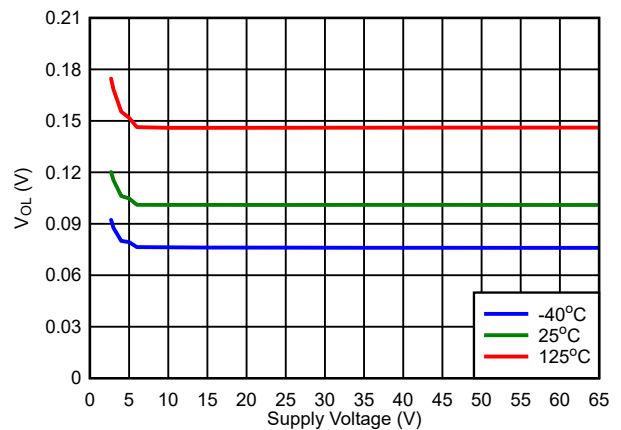
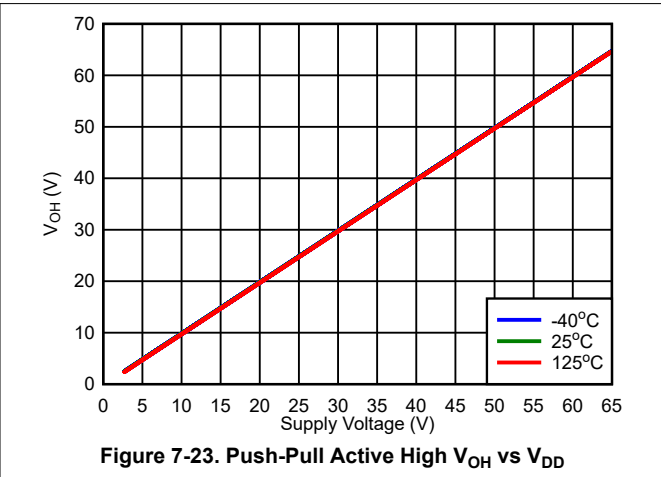
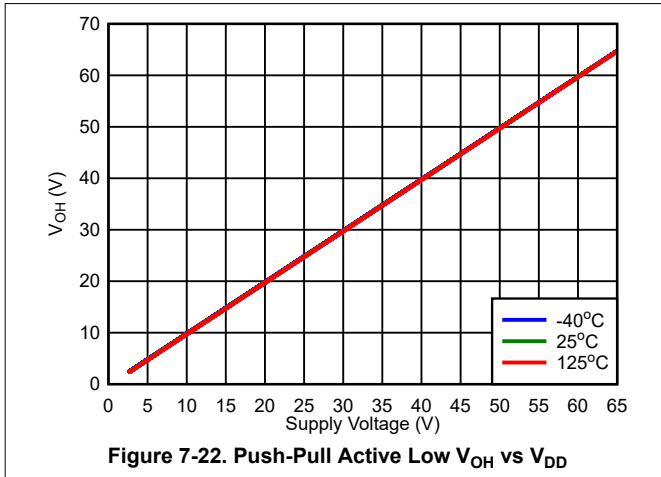

Figure 7-21. Push-Pull Active High V_{OL} vs V_{DD}

7.8 Typical Characteristics (continued)

Typical characteristics show the typical performance of the device. Test conditions are $T_A = 25^\circ\text{C}$, $R_{PU} = 100\text{ k}\Omega$, $C_{Load} = 50\text{ pF}$, unless otherwise noted.



8 Detailed Description

8.1 Overview

The TPS3760 is a family of high voltage and low quiescent current reset ICs with fixed threshold voltage. A voltage divider is integrated to eliminate the need for external resistors and eliminate leakage current that comes with resistor dividers. However, it can also support an external resistor if required by the application. The lowest threshold 800 mV (bypass internal resistor ladder) is recommended for external resistors use case to take advantage of faster detection time and lower I_{SENSE} current.

VDD, SENSE and RESET pins can support 65 V continuous operation; both VDD and SENSE voltage levels can be independent of each other, meaning VDD pin can be connected at 2.7 V while SENSE pins are connected to a higher voltage. Note, the TPS3760 does not have clamps within the device so external circuits or devices must be added to limit the voltages to the absolute maximum limit.

Additional features include programmable sense time delay (CTS) and reset delay time and manual reset (CTR / \overline{MR}).

8.2 Functional Block Diagram

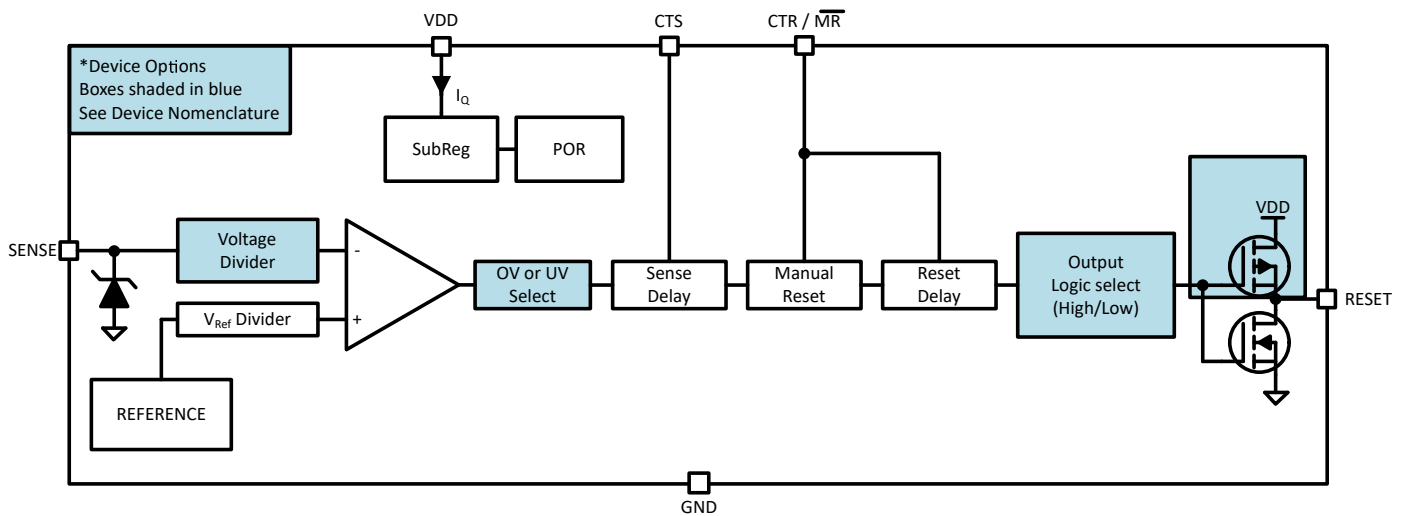

Figure 8-1. Functional Block Diagram ¹

¹ Refer to [Section 5](#) for complete list of topologies and output logic combination

8.3 Feature Description

8.3.1 Input Voltage (VDD)

VDD operating voltage ranges from 2.7 V to 65 V. An input supply capacitor is not required for this device; however, if the input supply is noisy good analog practice is to place a 0.1 μ F capacitor between the VDD and GND.

VDD needs to be at or above $V_{DD(MIN)}$ for at least the start-up time delay (t_{SD}) for the device to be fully functional.

VDD voltage is independent of V_{SENSE} and V_{RESET} , meaning that VDD can be higher or lower than the other pins.

8.3.1.1 Undervoltage Lockout ($V_{POR} < V_{DD} < UVLO$)

When the voltage on VDD is less than the UVLO voltage, but greater than the power-on reset voltage (V_{POR}), the output pins will be in reset, regardless of the voltage at SENSE pins.

8.3.1.2 Power-On Reset ($V_{DD} < V_{POR}$)

When the voltage on VDD is lower than the power on reset voltage (V_{POR}), the output signal is undefined and is not to be relied upon for proper device function.

Note: [Figure 8-2](#) and [Figure 8-3](#) assume an external pull-up resistor is connected to the reset pin via VDD.

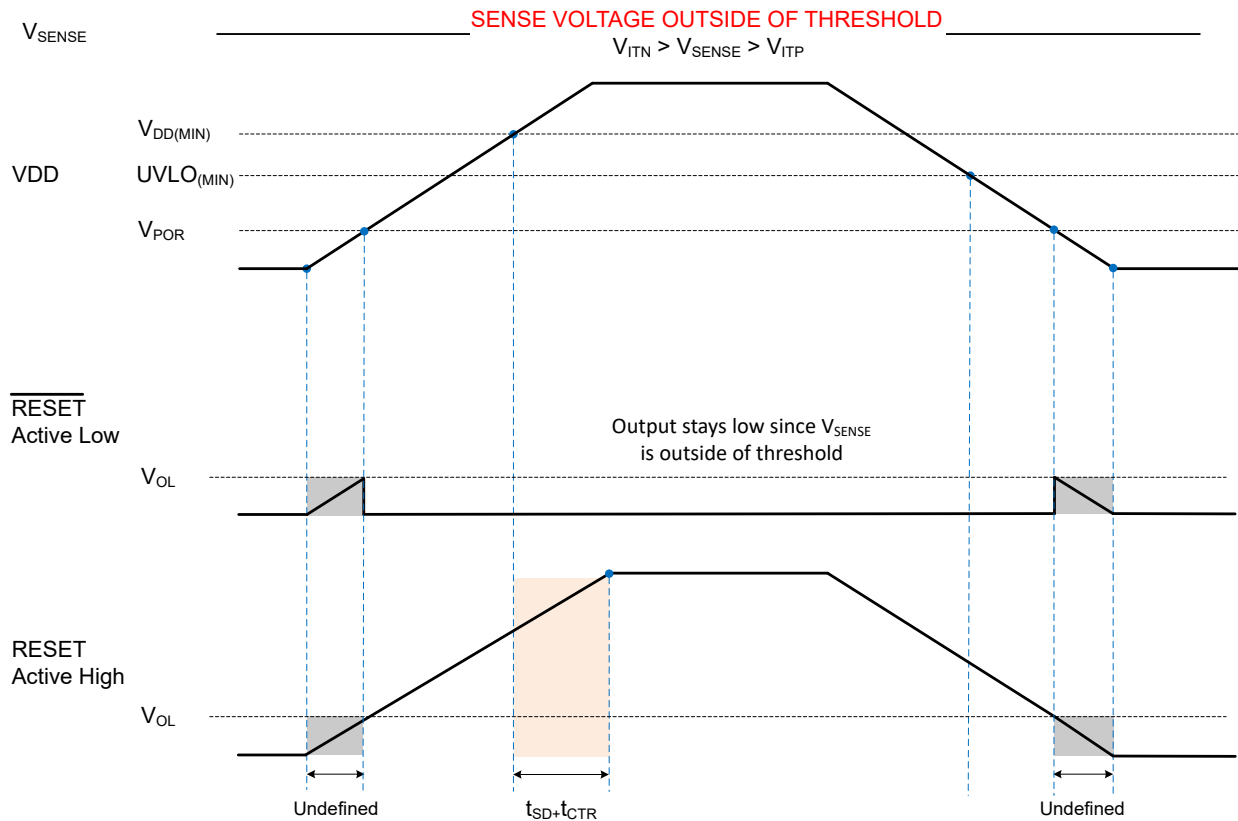

Figure 8-2. Power Cycle (SENSE Outside of Nominal Voltage)

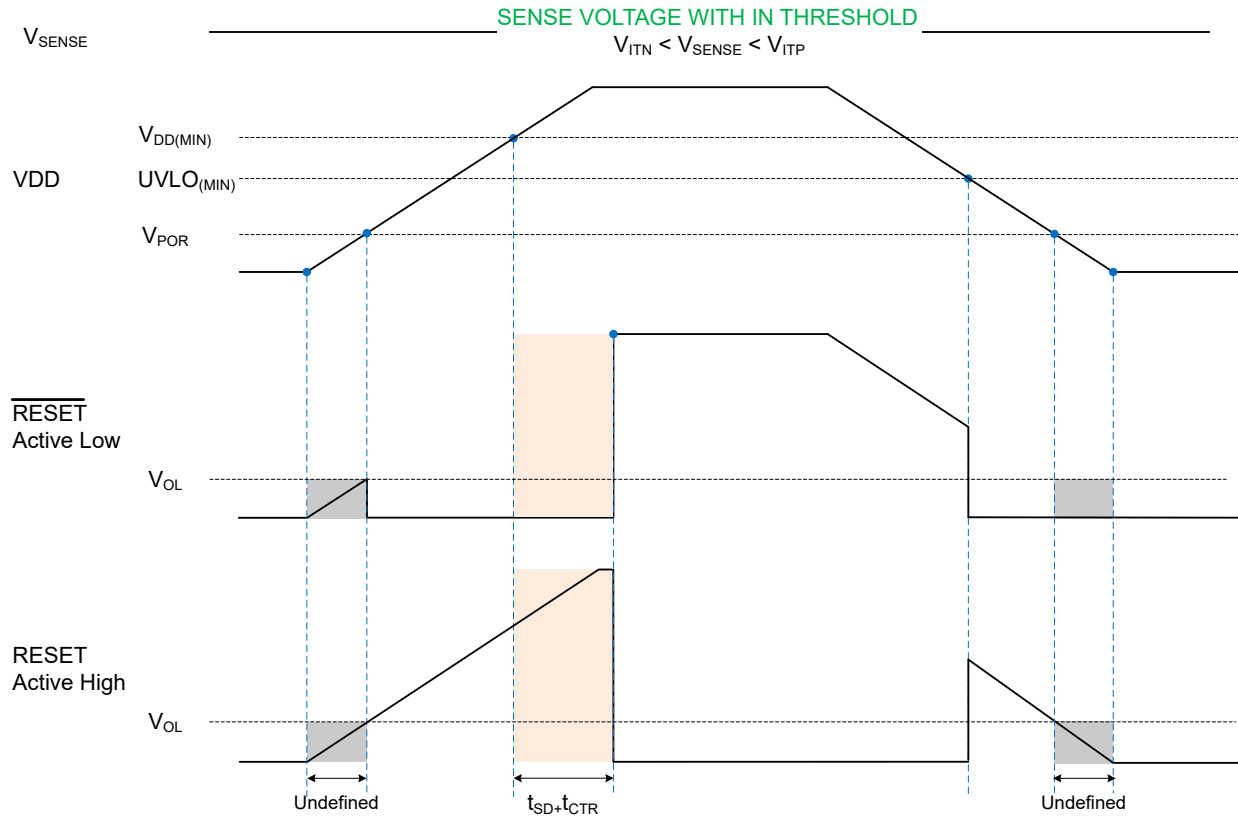

Figure 8-3. Power Cycle (SENSE Within Nominal Voltage)

8.3.2 SENSE

The TPS3760 high voltage family integrates a voltage comparator, a precision reference voltage and a trimmed resistor divider. This configuration optimizes device accuracy because all resistor tolerances are accounted for in the accuracy and performance specifications. Device also has built-in hysteresis that provides noise immunity and ensures stable operation.

Although not required in most cases, for noisy applications good analog design practice is to place a 10 nF to 100 nF bypass capacitor at the SENSE inputs in order to reduce sensitivity to transient voltages on the monitored signal. SENSE can be connected directly to VDD pin.

8.3.2.1 SENSE Hysteresis

Built-in hysteresis to avoid erroneous output reset release. The hysteresis is opposite to the threshold voltage; for overvoltage options the hysteresis is subtracted from the positive threshold (V_{ITP}), for undervoltage options hysteresis is added to the negative threshold (V_{ITN}).

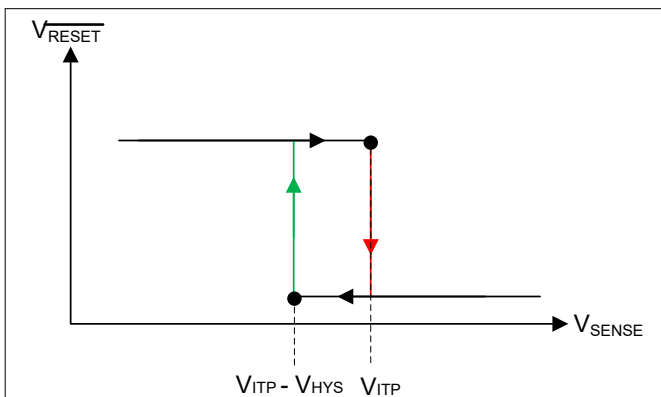

Figure 8-4. Hysteresis (Overvoltage Active-Low)

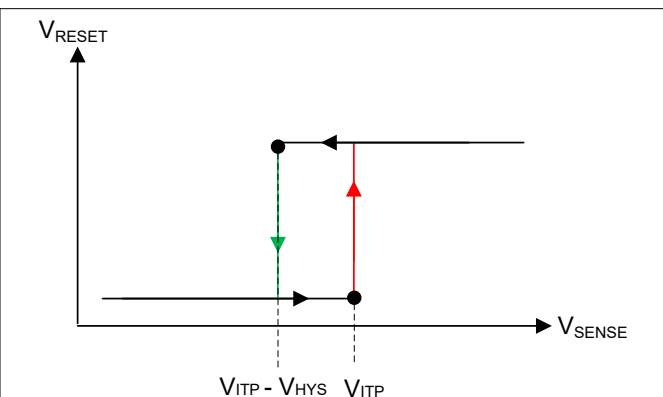

Figure 8-5. Hysteresis (Overvoltage Active-High)

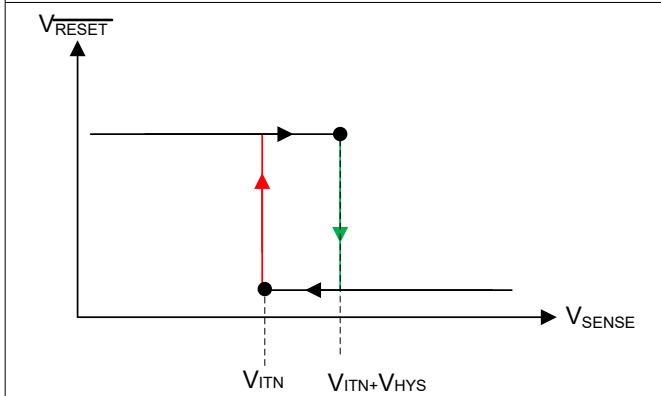

Figure 8-6. Hysteresis (Undervoltage Active-High)

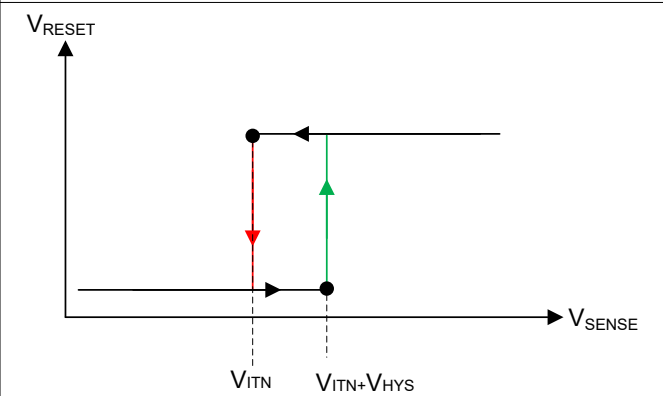

Figure 8-7. Hysteresis (Undervoltage Active-Low)

Table 8-1. Common Hysteresis Lookup Table

TARGET			DEVICE ACTUAL HYSTERESIS OPTION
DETECT THRESHOLD	TOPOLOGY	RELEASE VOLTAGE (V)	
18.0 V	Overtoltage	17.5 V	-3%
18.0 V	Overtoltage	16.0 V	-11%
17.0 V	Overtoltage	16.5 V	-3%
16.0 V	Overtoltage	15.0 V	-6%
15.0 V	Overtoltage	14.0 V	-7%
6.0 V	Undervoltage	6.5 V	0.5 V
5.5 V	Undervoltage	6 V	0.5 V
8 V	Undervoltage	9 V	1 V
5 V	Undervoltage	7.5 V	2.5 V

Table 8-1 shows a sample of hysteresis and voltage options for the TPS3760. For threshold voltages ranging from 2.7 V to 8 V, one option is to select a fixed hysteresis value ranging from 0.5 V to 2.5 V in increments of 0.5 V. Additionally, a second option can be selected where the hysteresis value is a percentage of the threshold voltage. The percentage of voltage hysteresis ranges from 2% to 13%.

Knowing the amount of hysteresis voltage, the release voltage for the undervoltage (UV) channel is $(V_{ITN(UV)} + V_{HYS})$ and for the overvoltage (OV) channel is $(V_{ITP(OV)} - V_{HYS})$. The accuracy of the release voltage, or stated in the Electrical Characteristics as *Hysteresis Accuracy* is $\pm 1.5\%$. Expanding what is shown in Table 8-1, below are a few voltage hysteresis examples that include the hysteresis accuracy:

Undervoltage (UV) Channel

$$V_{ITN} = 0.8 \text{ V}$$

$$\text{Voltage Hysteresis } (V_{HYS}) = 5\% = 40 \text{ mV}$$

$$\text{Hysteresis Accuracy} = \pm 1.5\% = 39.4 \text{ mV or } 40.6 \text{ mV}$$

$$\text{Release Voltage} = V_{ITN} + V_{HYS} = 839.4 \text{ mV to } 840.6 \text{ mV}$$

Overtoltage (OV) Channel

$$V_{ITP} = 8 \text{ V}$$

$$\text{Voltage Hysteresis } (V_{HYS}) = 2 \text{ V}$$

$$\text{Hysteresis Accuracy} = \pm 1.5\% = 1.97 \text{ V or } 2.03 \text{ V}$$

$$\text{Release Voltage} = V_{ITN} - V_{HYS} = 5.97 \text{ V to } 6.03 \text{ V}$$

8.3.3 Output Logic Configurations

TPS3760 is a single channel device that has a single input sense pin and a single reset pin. The single channel is available as Open-Drain and Push-Pull.

The available output logic configuration combinations are shown in [Table 8-2](#).

Table 8-2. TPS3760 Output Logic

DESCRIPTION	NOMENCLATURE	VALUE
GPN	TPS3760 (+ topology)	CHANNEL CONFIGURATION
Topology (OV and UV only)	TPS3760A	UV OD L
• UV = Undervoltage	TPS3760B	UV PP L
• OV = Overvoltage	TPS3760C	UV OD H
• PP = Push-Pull	TPS3760D	UV PP H
• OD = Open-Drain	TPS3760E	OV OD L
• L = Active low	TPS3760F	OV PP L
• H = Active high	TPS3760G	OV OD H
	TPS3760H	OV PP H

8.3.3.1 Open-Drain

Open-drain output requires an external pull-up resistor to hold the voltage high to the required voltage logic. Connect the pull-up resistor to the proper voltage rail to enable the output to be connected to other devices at the correct interface voltage levels.

To select the right pull-up resistor consider system V_{OH} and the (I_{IKG}) current provided in the electrical characteristics, high resistors values will have a higher voltage drop affecting the output voltage high. The open-drain output can be connected as a wired-AND logic with other open-drain signals such as another TPS3760 open-drain output pin.

8.3.3.2 Push-Pull

Push-Pull output does not require an external resistor since is the output is internally pulled-up to VDD during V_{OH} condition and output will be connected to GND during V_{OH} condition.

8.3.3.3 Active-High (RESET)

RESET (active-high), denoted with no bar above the pin label. RESET remains low (V_{OL} , deasserted) as long as sense voltage is in normal operation within the threshold boundaries and VDD voltage is above UVLO. To assert a reset sense pins needs to meet the condition below:

- For undervoltage variant the SENSE voltage need to cross the lower boundary (V_{ITN}).
- For overvoltage variant the SENSE voltage needs to cross the upper boundary (V_{ITP}).

8.3.3.4 Active-Low (\overline{RESET})

\overline{RESET} (active low) denoted with a bar above the pin label. \overline{RESET} remains high voltage (V_{OH} , deasserted) (open-drain variant V_{OH} is measured against the pullup voltage) as long as sense voltage is in normal operation within the threshold boundaries and VDD voltage is above UVLO. To assert a reset sense pins needs to meet the condition below:

- For undervoltage variant the SENSE voltage need to cross the lower boundary (V_{ITN}).
- For overvoltage variant the SENSE voltage needs to cross the upper boundary (V_{ITP}).

8.3.4 User-Programmable Reset Time Delay

TPS3760 has adjustable reset release time delay with external capacitors.

- A capacitor in CTR / \overline{MR} programs the reset time delay of the output.
- No capacitor on this pin gives the fastest reset delay time indicated in the [Section 7.6](#).

8.3.4.1 Reset Time Delay Configuration

The time delay (t_{CTR}) can be programmed by connecting a capacitor between CTR pin and GND.

The relationship between external capacitor $C_{CTR_EXT (typ)}$ and the time delay $t_{CTR (typ)}$ is given by [Equation 1](#).

$$t_{CTR (typ)} = -\ln(0.28) \times R_{CTR (typ)} \times C_{CTR_EXT (typ)} + t_{CTR (no\ cap)} \quad (1)$$

$R_{CTR (typ)}$ = is in kilo ohms (kOhms)

$C_{CTR_EXT (typ)}$ = is given in microfarads (μF)

$t_{CTR (typ)}$ = is the reset time delay (ms)

The reset delay varies according to three variables: the external capacitor (C_{CTR_EXT}), CTR pin internal resistance (R_{CTR}) provided in [Section 7](#), and a constant. The minimum and maximum variance due to the constant is show in [Equation 2](#) and [Equation 3](#):

$$t_{CTR (min)} = -\ln(0.31) \times R_{CTR (min)} \times C_{CTR_EXT (min)} + t_{CTR (no\ cap (min))} \quad (2)$$

$$t_{CTR (max)} = -\ln(0.25) \times R_{CTR (max)} \times C_{CTR_EXT (max)} + t_{CTR (no\ cap (max))} \quad (3)$$

The recommended maximum reset delay capacitor for the TPS3760 is limited to 10 μF as this ensures enough time for the capacitor to fully discharge when a voltage fault occurs. Also, having a too large of a capacitor value can cause very slow charge up (rise times) due to capacitor leakage and system noise can cause the the internal circuit to trip earlier or later near the threshold. This leads to variation in time delay where it can make the delay accuracy worse in the presence of system noise.

When a voltage fault occurs, the previously charged up capacitor discharges and if the monitored voltage returns from the fault condition before the delay capacitor discharges completely, the delay will be shorter than expected. The capacitor will begin charging from a voltage above zero and resulting in shorter than expected time delay. A larger delay capacitor can be used so long as the capacitor has enough time to fully discharge during the duration of the voltage fault. To ensure the capacitor is fully discharged, the time period or duration of the voltage fault needs to be greater than 5% of the programmed reset time delay.

8.3.5 User-Programmable Sense Delay

TPS3760 has adjustable sense release time delay with external capacitors.

- A capacitor in CTS programs the excursion detection on SENSE.
- No capacitor on these pins gives the fastest detection time indicated in the [Section 7.6](#).

8.3.5.1 Sense Time Delay Configuration

The time delay (t_{CTS}) can be programmed by connecting a capacitor between CTS pin and GND.

The relationship between external capacitor $C_{CTS_EXT (typ)}$ and the time delay $t_{CTS (typ)}$ is given by [Equation 4](#).

$$t_{CTS (typ)} = -\ln(0.28) \times R_{CTS (typ)} \times C_{CTS_EXT (typ)} + t_{CTS (no\ cap)} \quad (4)$$

R_{CTS} = is in kilo ohms (kOhms)

C_{CTS_EXT} = is given in microfarads (μF)

t_{CTS} = is the sense time delay (ms)

The sense delay varies according to three variables: the external capacitor (C_{CTS_EXT}), CTS pin internal resistance (R_{CTS}) provided in Electrical Characteristics, and a constant. The minimum and maximum variance due to the constant is show in [Equation 5](#) and [Equation 6](#):

$$t_{CTS (min)} = -\ln(0.31) \times R_{CTS (min)} \times C_{CTS_EXT (min)} + t_{CTS (no\ cap (min))} \quad (5)$$

$$t_{CTS (max)} = -\ln(0.25) \times R_{CTS (max)} \times C_{CTS_EXT (max)} + t_{CTSx (no\ cap (max))} \quad (6)$$

The recommended maximum sense delay capacitor for the is limited to 10 μF as this ensures enough time for the capacitor to fully discharge when a voltage fault occurs. Also, having a too large of a capacitor value can cause very slow charge up (rise times) and system noise can cause the the internal circuit to trip earlier or later near the threshold. This leads to variation in time delay where it can make the delay accuracy worse in the presence of system noise.

When a voltage fault occurs, the previously charged up capacitor discharges and if the monitored voltage returns from the fault condition before the delay capacitor discharges completely, the delay will be shorter than expected. The capacitor will begin charging from a voltage above zero and resulting in shorter than expected time delay. A larger delay capacitor can be used so long as the capacitor has enough time between fault events to fully discharge during the duration of the voltage fault. To ensure the capacitor is fully discharged, the time period or time duration between fault events needs to be greater than 10% of the programmed sense time delay.

8.3.6 Manual RESET (CTR / \overline{MR}) Input

The manual reset input allows a processor or other logic circuits to initiate a reset. In this section \overline{MR} is a generic reference to (CTR / \overline{MR}). A logic low on \overline{MR} causes \overline{RESET} to assert on reset output. After \overline{MR} is left floating, \overline{RESET} will release the reset if the voltage at SENSE pin is at nominal voltage. \overline{MR} should not be driven high, this pin should be left floating or connected to a capacitor to GND, this pin can be left unconnected if is not used.

If the logic driving the \overline{MR} cannot tri-state (floating and GND) then a logic-level FET should be used as illustrated in Figure 8-8.

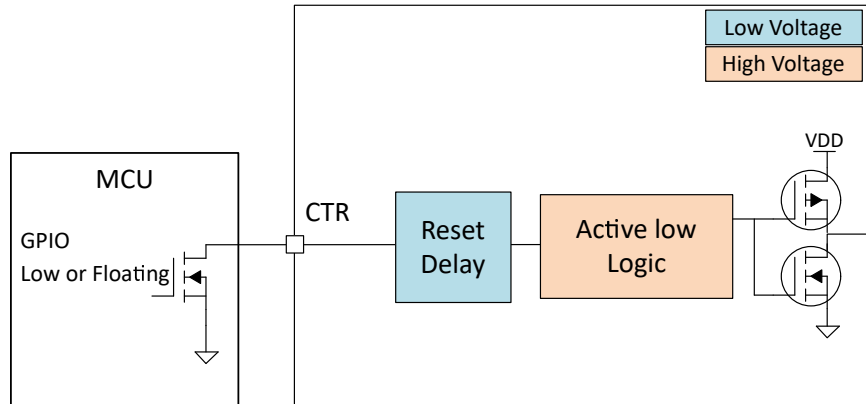

Figure 8-8. Manual Reset Implementation

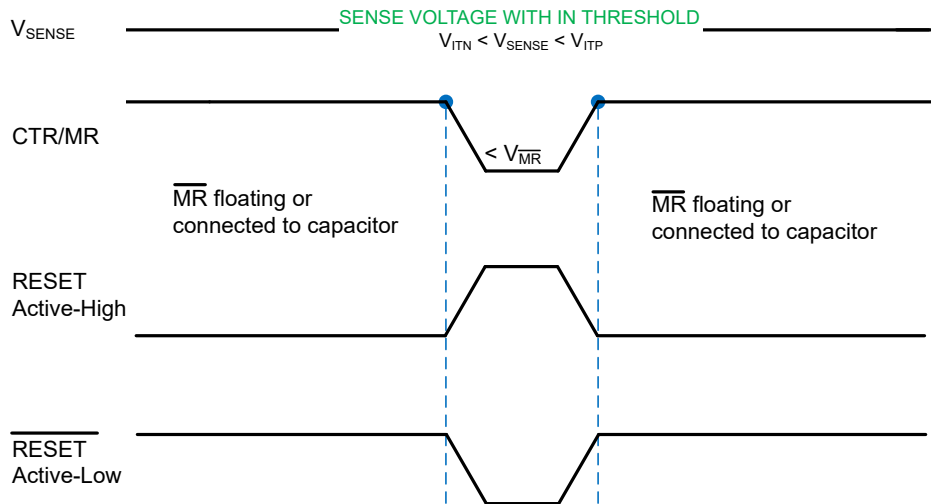

Figure 8-9. Manual Reset Timing Diagram

Table 8-3. \overline{MR} Functional Table

\overline{MR}	SENSE ON NOMINAL VOLTAGE	RESET STATUS
Low	Yes	Reset asserted
Floating	Yes	Fast reset release when SENSE voltage goes back to nominal voltage
Capacitor	Yes	Programmable reset time delay
High	Yes	NOT Recommended

8.3.7 RESET Latch Mode

The TPS3760 features a output latch mode on the RESET/RESETE pin when connecting the LATCH pin to common ground. A pull-down resistor, 10 kΩ, is recommended to limit current consumption of the system. In latch mode, if the RESET/RESETE pin is low or triggers low and less than 1.4V is applied to the LATCH pin, the RESET/RESETE pin stays asserted regardless if VSENSE goes within the acceptable voltage boundaries ($V_{SENSE} > V_{ITP} + V_{hyst}$ for UV or $V_{SENSE} < V_{ITN} - V_{hyst}$ for OV). To unlatch the device a voltage greater than 2.1 V for greater than 3 μs is applied to the LATCH pin. This is recommended to maintain a proper unlatch. The RESET/RESETE pin triggers high after the duration of t_{ctr} . TI recommends using a series resistance to limit current when an unlatch voltage is applied.

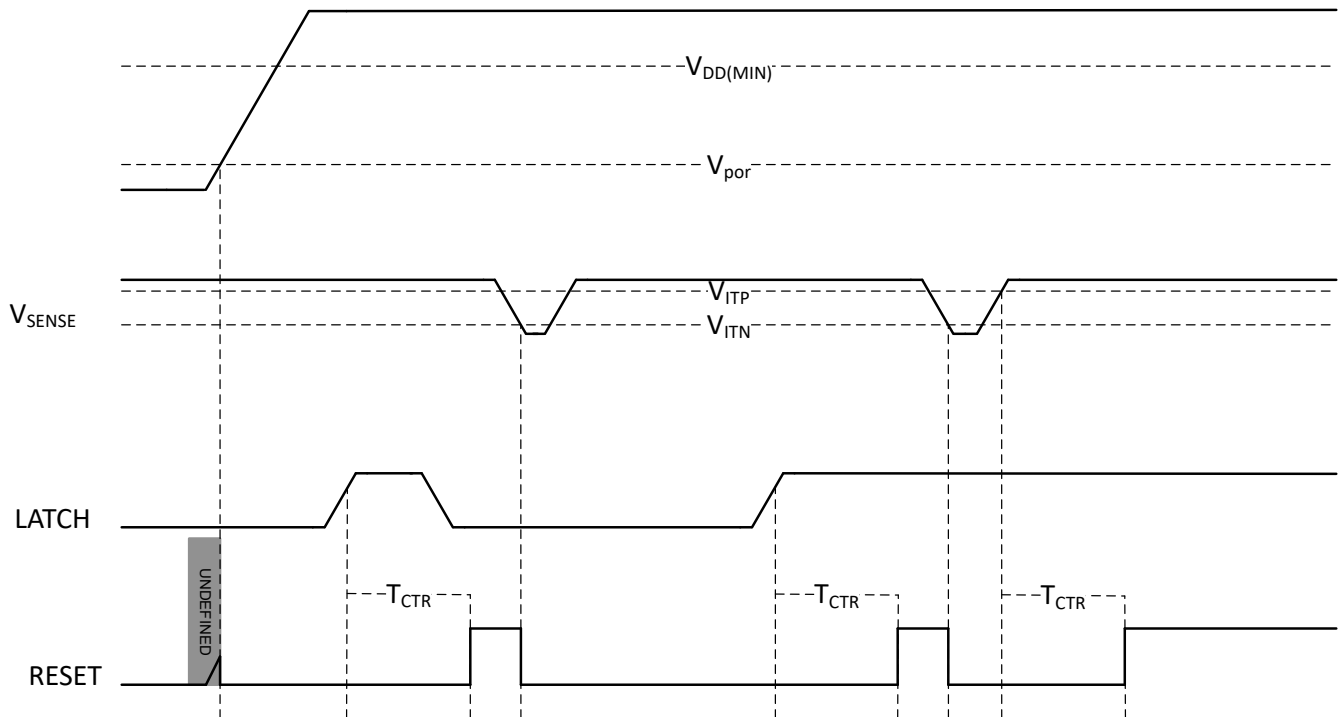

Figure 8-10. Latch Timing Diagram

8.4 Device Functional Modes

Table 8-4. Undervoltage Detect Functional Mode Truth Table

DESCRIPTION	SENSE		CTR ⁽¹⁾ / MR PIN	VDD PIN	OUTPUT ⁽²⁾ (RESET PIN)
	PREVIOUS CONDITION	CURRENT CONDITION			
Normal Operation	$SENSE > V_{ITN(UV)}$	$SENSE > V_{ITN(UV)}$	Open or capacitor connected	$V_{DD} > V_{DD(MIN)}$	High
Undervoltage Detection	$SENSE > V_{ITN(UV)}$	$SENSE < V_{ITN(UV)}$	Open or capacitor connected	$V_{DD} > V_{DD(MIN)}$	Low
Undervoltage Detection	$SENSE < V_{ITN(UV)}$	$SENSE > V_{ITN(UV)}$	Open or capacitor connected	$V_{DD} > V_{DD(MIN)}$	Low
Normal Operation	$SENSE < V_{ITN(UV)}$	$SENSE > V_{ITN(UV)} + HYS$	Open or capacitor connected	$V_{DD} > V_{DD(MIN)}$	High
Manual Reset	$SENSE > V_{ITN(UV)}$	$SENSE > V_{ITN(UV)}$	Low	$V_{DD} > V_{DD(MIN)}$	Low
UVLO Engaged	$SENSE > V_{ITN(UV)}$	$SENSE > V_{ITN(UV)}$	Open or capacitor connected	$V_{POR} < V_{DD} < V_{DD(MIN)}$	Low
Below V_{POR} , Undefined Output	$SENSE > V_{ITN(UV)}$	$SENSE > V_{ITN(UV)}$	Open or capacitor connected	$V_{DD} < V_{POR}$	Undefined

(1) Reset time delay is ignored in the truth table.

(2) Open-drain active low output requires an external pull-up resistor to a pull-up voltage.

Table 8-5. Overvoltage Detect Functional Mode Truth Table

DESCRIPTION	SENSE		CTR ⁽¹⁾ / MR PIN	VDD PIN	OUTPUT ⁽²⁾ (RESET PIN)
	PREVIOUS CONDITION	CURRENT CONDITION			
Normal Operation	$SENSE < V_{ITN(OV)}$	$SENSE < V_{ITN(OV)}$	Open or capacitor connected	$V_{DD} > V_{DD(MIN)}$	High
Overvoltage Detection	$SENSE < V_{ITN(OV)}$	$SENSE > V_{ITN(OV)}$	Open or capacitor connected	$V_{DD} > V_{DD(MIN)}$	Low
Overvoltage Detection	$SENSE > V_{ITN(OV)}$	$SENSE < V_{ITN(OV)}$	Open or capacitor connected	$V_{DD} > V_{DD(MIN)}$	Low
Normal Operation	$SENSE > V_{ITN(OV)}$	$SENSE < V_{ITN(OV)} - HYS$	Open or capacitor connected	$V_{DD} > V_{DD(MIN)}$	High
Manual Reset	$SENSE < V_{ITN(OV)}$	$SENSE < V_{ITN(OV)}$	Low	$V_{DD} > V_{DD(MIN)}$	Low
UVLO Engaged	$SENSE < V_{ITN(OV)}$	$SENSE < V_{ITN(OV)}$	Open or capacitor connected	$V_{POR} < V_{DD} < UVLO$	Low
Below V_{POR} , Undefined Output	$SENSE < V_{ITN(OV)}$	$SENSE < V_{ITN(OV)}$	Open or capacitor connected	$V_{DD} < V_{POR}$	Undefined

(1) Reset time delay is ignored in the truth table.

(2) Open-drain active low output requires an external pull-up resistor to a pull-up voltage.

9 Application and Implementation

Note

Information in the following applications sections is not part of the TI component specification, and TI does not warrant its accuracy or completeness. TI's customers are responsible for determining suitability of components for their purposes, as well as validating and testing their design implementation to confirm system functionality.

9.1 Application Information

The following sections describe in detail how to properly use this device. As this device has many applications and setups, there are many situations that this datasheet can not characterize in detail and will vary from these applications depending on the requirements of the final application

9.2 Adjustable Voltage Thresholds

Equation 7 illustrates an example of how to adjust the voltage threshold with external resistor dividers. The resistors can be calculated depending on the desired voltage threshold and device part number. TI recommends using the 0.8 V voltage threshold device when using an adjustable voltage variant. This variant bypasses the internal resistor ladder.

For example, consider a 12 V rail being monitored V_{MON} for undervoltage (UV) using of the TPS3760A012DYR variant. Using Equation 7 and shown in Equation 8, R_1 is the top resistor of the resistor divider that is between V_{MON} and V_{SENSE} , R_2 is the bottom resistor that is between V_{SENSE} and GND, V_{MON} is the voltage rail that is being monitored and V_{SENSE} is the input threshold voltage. The monitored UV threshold, denoted as V_{MON-} , where the device will assert a reset signal occurs when $V_{SENSE} = V_{IT-(UV)}$ or, for this example, $V_{MON-} = 10.8V$ which is 90% from 12 V. Using Equation 7 and assuming $R_2 = 10k\Omega$, R_1 can be calculated shown in Equation 8 where I_{R1} is represented in Equation 9:

$$V_{SENSE} = V_{MON-} \times (R_2 \div (R_1 + R_2)) \quad (7)$$

$$R_1 = (V_{MON-} - V_{SENSE}) \div I_{R1} \quad (8)$$

$$I_{R1} = I_{R2} = V_{SENSE} \div R_2 \quad (9)$$

Substituting Equation 9 into Equation 8 and solving for R_1 in Equation 7, $R_1 = 125k\Omega$. The TPS3760A012DYR is typically meant to monitor a 0.8 V rail with $\pm 2\%$ voltage threshold hysteresis. For the reset signal to become deasserted, V_{MON} would need to go above $V_{IT-} + V_{HYS}$. For this example, $V_{MON} = 11.016 V$ when the reset signal becomes deasserted.

There are inaccuracies that must be taken into consideration while adjusting voltage thresholds. Aside from the tolerance of the resistor divider, there is an internal resistance of the SENSE pin that may affect the accuracy of the resistor divider. Although expected to be very high impedance, users are recommended to calculate the values for the design specifications. The internal SENSE resistance R_{SENSE} can be calculated by the SENSE voltage V_{SENSE} divided by the SENSE current I_{SENSE} as shown in Equation 11. V_{SENSE} can be calculated using Equation 7 depending on the resistor divider and monitored voltage. I_{SENSE} can be calculated using Equation 10.

$$I_{SENSE} = [(V_{MON} - V_{SENSE}) \div R_1] - (V_{SENSE} \div R_2) \quad (10)$$

$$R_{SENSE} = V_{SENSE} \div I_{SENSE} \quad (11)$$

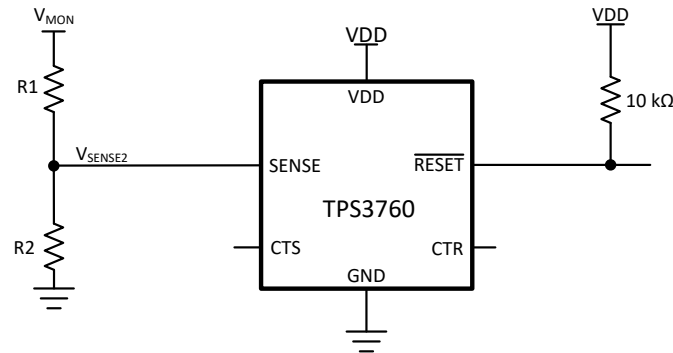

Figure 9-1. Adjustable Voltage Threshold with External Resistor Dividers

9.3 Typical Application

9.3.1 Design 1: Off-Battery Monitoring

This application is intended for the initial power stage in applications with the 12 V batteries. Variation of the battery voltage is common between 9 V and 16 V. Furthermore, if cold-cranking and load dump conditions are considered, voltage transients can occur as low as 3 V and as high as 42 V. In this design example, we are highlighting the ability for low power, direct off-battery voltage supervision.

Figure 11-1 illustrates an example of how the TPS3760 is monitoring the battery voltage while being powered by it, as well.

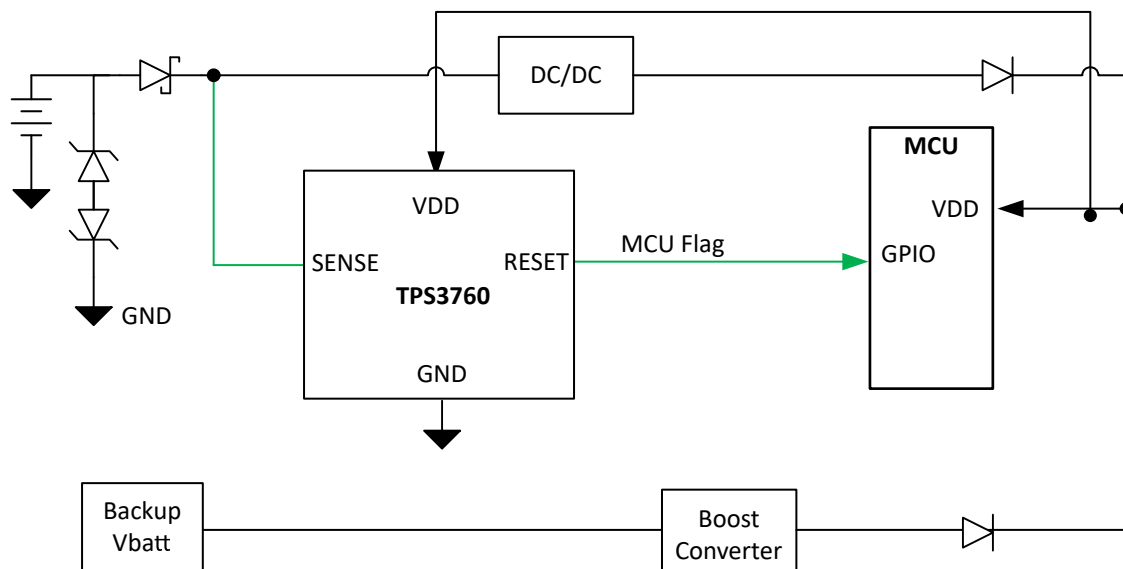

Figure 9-2. TPS3760 Overvoltage Supervisor with Direct Off-Battery Monitoring

9.3.1.1 Design Requirements

This design requires voltage supervision on a 12 V power supply voltage rail with possibility of the 12 V rail rising up as high as 42 V. The undervoltage fault occurs when the power supply voltage drops below 7.7 V.

PARAMETER	DESIGN REQUIREMENT	DESIGN RESULT
Power Rail Voltage Supervision	Monitor 12-V power supply for undervoltage condition, trigger a undervoltage fault at 7.7 V.	TPS3760 provides voltage monitoring with 1.5% max accuracy with adjustable/non-adjustable variations.
Maximum Input Power	Operate with power supply input up to 42 V.	The TPS3760 can support a VDD of up to 65 V.
Output logic voltage	Open-Drain Output Topology	An open-drain output is recommended to provide the correct reset signal, but a push-pull can also be used.
Maximum system current consumption	2 μ A max when power supply is at 12 V typical	TPS3760 allows for I_Q to remain low with support of up to 65 V. This allows for no external resistor divider to be required.
Voltage Monitor Accuracy	Maximum voltage monitor accuracy of 1.5%.	The TPS3760 has 1.5% maximum voltage monitor accuracy.
Delay when returning from fault condition	$\overline{\text{RESET}}$ delay of at least 12.8 ms when returning from a undervoltage fault.	$C_{CTR} = 10 \text{ nF}$ sets 12.8 ms delay

9.3.1.2 Detailed Design Procedure

The primary advantage of this application is being able to directly monitor a voltage on an automotive battery without needing external an resistor dividers on the SENSE input. This keeps the overall I_Q of the design low while still achieving the desired rail monitoring.

Voltage rail monitoring is done by connecting the SENSE input directly to the battery rail after the TVS protection diodes. The TPS3760 that is being used in this example is a fixed voltage variant where the SENSE threshold voltage has been set internally. Word of caution, the TVS protection diodes must be chosen such that the transient voltages on the monitored rails do not exceed the absolute max limit listed in [Section 7.1](#).

To use this configuration, the specific voltage threshold variation of the device must be chosen according to the application. In this configuration, the '77' variation must be chosen for 7.7 V as shown in [Section 5](#).

The device being able to handle 65 V on VDD means the monitored voltage rail can go as high as 42 V for the application transients and not violate the recommended maximum for the supervisor as it usually would. This is useful when monitoring a voltage rail that has a wide range that may go much higher than the nominal rail voltage such as in this case. Good design practice recommends using a 0.1 μ F capacitor on the VDD pin and this capacitance may need to increase if using an adjustable version with a resistor divider.

9.3.1.3 Application Curves

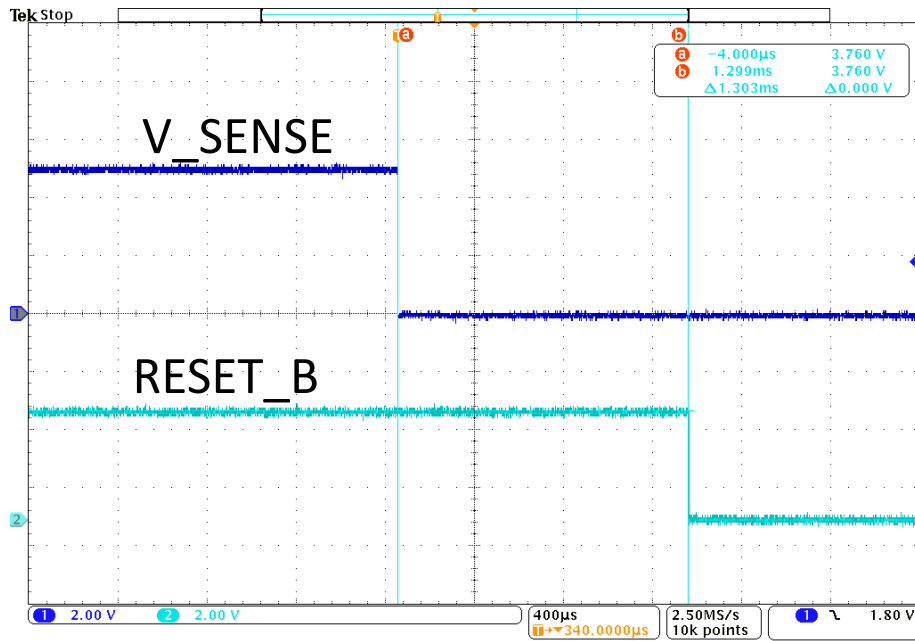

Figure 9-3. Undervoltage Reset Waveform

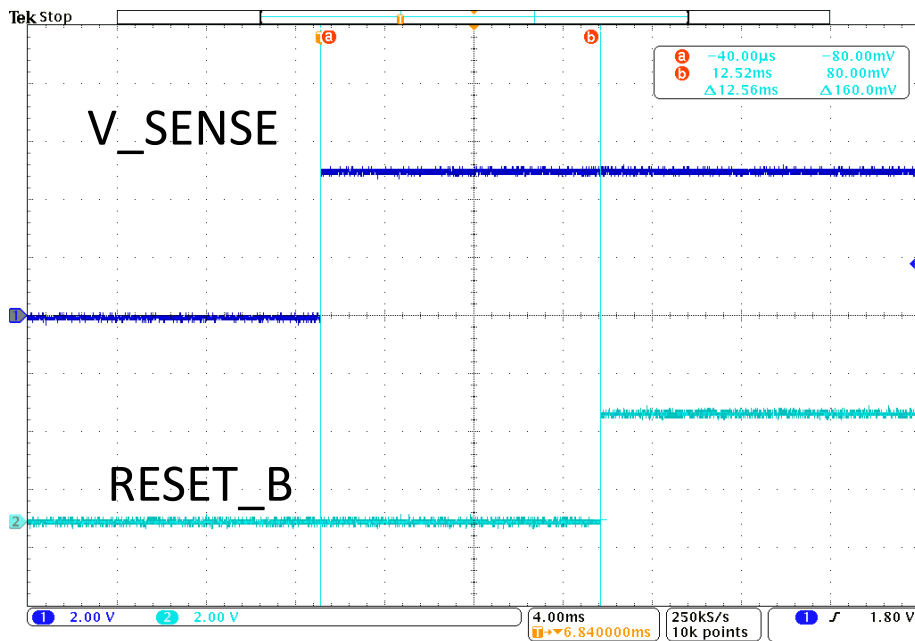

Figure 9-4. Undervoltage Recovery Waveform

10 Power Supply Recommendations

These devices are designed to operate from an input supply with a voltage range between 1.4 V (V_{POR}) to 65 V (maximum operation). Good analog design practice recommends placing a minimum 0.1 μ F ceramic capacitor as near as possible to the VDD pin.

10.1 Power Dissipation and Device Operation

The permissible power dissipation for any package is a measure of the capability of the device to pass heat from the power source, the junctions of the IC, to the ultimate heat sink, the ambient environment. Thus, the power dissipation is dependent on the ambient temperature and the thermal resistance across the various interfaces between the die junction and ambient air.

The maximum continuous allowable power dissipation for the device in a given package can be calculated using [Equation 12](#):

$$P_{D-MAX} = ((T_{J-MAX} - T_A) / R_{\theta JA}) \quad (12)$$

The actual power being dissipated in the device can be represented by [Equation 13](#):

$$P_D = V_{DD} \times I_{DD} + P_{RESET} \quad (13)$$

P_{RESET} is calculated by [Equation 14](#) or [Equation 15](#)

$$P_{RESET (PUSH/PULL)} = V_{DD} - V_{RESET} \times I_{RESET} \quad (14)$$

$$P_{RESET (OPEN-DRAIN)} = V_{RESET} \times I_{RESET} \quad (15)$$

[Equation 12](#) and [Equation 13](#) establish the relationship between the maximum power dissipation allowed due to thermal consideration, the voltage drop across the device, and the continuous current capability of the device. These two equations should be used to determine the optimum operating conditions for the device in the application.

In applications where lower power dissipation (P_D) and/or excellent package thermal resistance ($R_{\theta JA}$) is present, the maximum ambient temperature (T_{A-MAX}) may be increased.

In applications where high power dissipation and/or poor package thermal resistance is present, the maximum ambient temperature (T_{A-MAX}) may have to be de-rated. T_{A-MAX} is dependent on the maximum operating junction temperature ($T_{J-MAX-OP} = 125^\circ\text{C}$), the maximum allowable power dissipation in the device package in the application (P_{D-MAX}), and the junction-to ambient thermal resistance of the part/package in the application ($R_{\theta JA}$), as given by [Equation 16](#):

$$T_{A-MAX} = (T_{J-MAX-OP} - (R_{\theta JA} \times P_{D-MAX})) \quad (16)$$

11 Layout

11.1 Layout Guidelines

- Make sure that the connection to the VDD pin is low impedance. Good analog design practice is to place a greater than 0.1 μF ceramic capacitor as near as possible to the VDD pin.
- To further improve the noise immunity on the SENSE pins, placing a 10 nF to 100 nF capacitor between the SENSE pin and GND can reduce the sensitivity to transient voltages on the monitored signal.
- If a capacitor is used on CTS or CTR, place these components as close as possible to the respective pins. If the capacitor adjustable pins are left unconnected, make sure to minimize the amount of parasitic capacitance on the pins to less than 5 pF.
- For open-drain variants, place the pull-up resistors on $\overline{\text{RESET}}$ as close to the pin as possible.
- When laying out metal traces, separate high voltage traces from low voltage traces as much as possible. If high and low voltage traces need to run close by, spacing between traces should be greater than 20 mils (0.5 mm).
- Do not have high voltage metal pads or traces closer than 20 mils (0.5 mm) to the low voltage metal pads or traces.

11.2 Layout Example

The layout example in [Figure 11-1](#) shows how the TPS3760 is laid out on a printed circuit board (PCB) with user-defined delays.

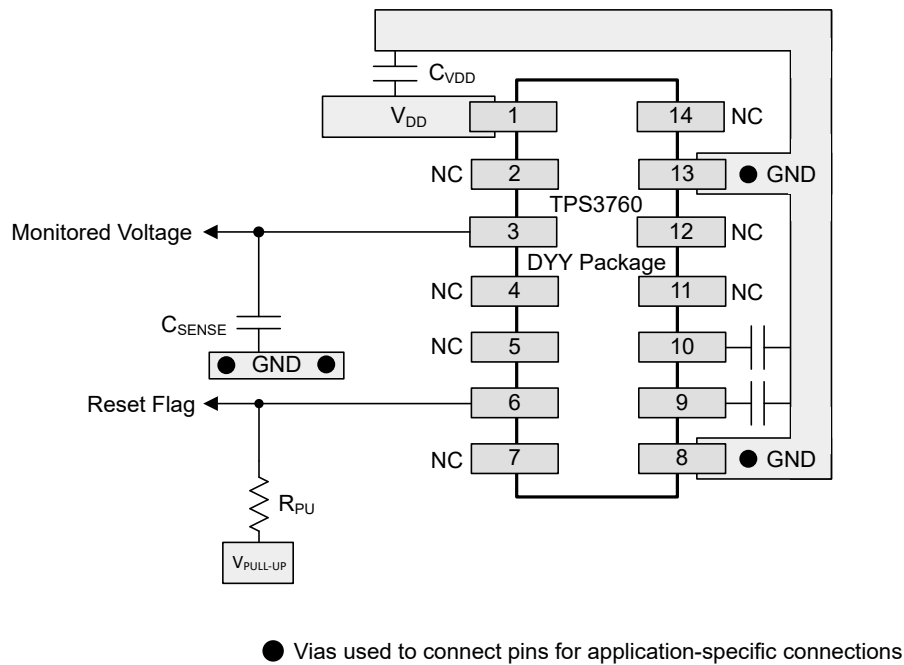

Figure 11-1. TPS3760 Recommended Layout

11.3 Creepage Distance

Per IEC 60664 Creepage is the shortest distance between two conductive parts or as shown in [Figure 11-2](#) the distance between high voltage conductive parts and grounded parts, the floating conductive part is ignored and subtracted from the total distance.

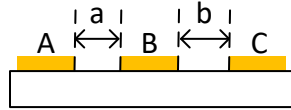

Figure 11-2. Creepage Distance

[Figure 11-2](#) details

- A = Left pins (high voltage)
- B = Central pad (conductive not internally connected, can be left floating or connected to GND)
- C = Right pins (low voltages)
- Creepage distance = $a + b$

12 Device and Documentation Support

12.1 Device Nomenclature

Section 5 shows how to decode the function of the device based on its part number

Table 12-1 shows possible voltage options per channel. Contact TI sales representatives or on TI's E2E forum for details and availability of other options; minimum order quantities apply.

Table 12-1. Voltage Options

100 mV STEPS				400 mV STEPS		500 mV STEPS		1 V STEPS	
NOMEN- CLATURE	VOLTAGE OPTIONS	NOMEN- CLATURE	VOLTAGE OPTIONS	NOMEN- CLATURE	VOLTAGE OPTIONS	NOMEN- CLATURE	VOLTAGE OPTIONS	NOMEN- CLATURE	VOLTAGE OPTIONS
01	800 mV (divider bypass)	70	7.0 V	A0	10.4 V	D0	20.5 V	F0	31.0 V
27	2.7 V	71	7.1 V	A1	10.8 V	D1	21.0 V	F1	32.0 V
28	2.8 V	72	7.2 V	A2	11.2 V	D2	21.5 V	F2	33.0 V
29	2.9 V	73	7.3 V	A3	11.6 V	D3	22.0 V	F3	34.0 V
30	3.0 V	74	7.4 V	A4	12.0 V	D4	22.5 V	F4	35.0 V
31	3.1 V	75	7.5 V	A5	12.4 V	D5	23.0 V	F5	36.0 V
32	3.2 V	76	7.6 V	A6	12.8 V	D6	23.5 V		
33	3.3 V	77	7.7 V	A7	13.2 V	D7	24.0 V		
34	3.4 V	78	7.8 V	A8	13.6 V	D8	24.5 V		
35	3.5 V	79	7.9 V	A9	14.0 V	D9	25.0 V		
36	3.6 V	80	8.0 V	B0	14.4 V	E0	25.5 V		
37	3.7 V	81	8.1 V	B1	14.8 V	E1	26.0 V		
38	3.8 V	82	8.2 V	B2	15.2 V	E2	26.5 V		
39	3.9 V	83	8.3 V	B3	15.6 V	E3	27.0 V		
40	4.0 V	84	8.4 V	B4	16.0 V	E4	27.5 V		
41	4.1 V	85	8.5 V	B5	16.4 V	E5	28.0 V		
42	4.2 V	86	8.6 V	B6	16.8 V	E6	28.5 V		
43	4.3 V	87	8.7 V	B7	17.2 V	E7	29.0 V		
44	4.4 V	88	8.8 V	B8	17.6 V	E8	29.5 V		
45	4.5 V	89	8.9 V	B9	18.0 V	E9	30.0 V		
46	4.6 V	90	9.0 V	C0	18.4 V				
47	4.7 V	91	9.1 V	C1	18.8 V				
48	4.8 V	92	9.2 V	C2	19.2 V				
49	4.9 V	93	9.3 V	C3	19.6 V				
50	5.0 V	94	9.4 V	C4	20.0 V				
51	5.1 V	95	9.5 V						
52	5.2 V	96	9.6 V						
53	5.3 V	97	9.7 V						
54	5.4 V	98	9.8 V						
55	5.5 V	99	9.9 V						
56	5.6 V	00	10.0 V						
57	5.7 V								
58	5.8 V								
59	5.9 V								
60	6.0 V								
61	6.1 V								

Table 12-1. Voltage Options (continued)

100 mV STEPS				400 mV STEPS		500 mV STEPS		1 V STEPS	
NOMEN- CLATURE	VOLTAGE OPTIONS	NOMEN- CLATURE	VOLTAGE OPTIONS	NOMEN- CLATURE	VOLTAGE OPTIONS	NOMEN- CLATURE	VOLTAGE OPTIONS	NOMEN- CLATURE	VOLTAGE OPTIONS
62	6.2 V								
63	6.3 V								
64	6.4 V								
65	6.5 V								
66	6.6 V								
67	6.7 V								
68	6.8 V								
69	6.9 V								

12.2 Receiving Notification of Documentation Updates

To receive notification of documentation updates, navigate to the device product folder on ti.com. Click on *Subscribe to updates* to register and receive a weekly digest of any product information that has changed. For change details, review the revision history included in any revised document.

12.3 Support Resources

[TI E2E™ support forums](#) are an engineer's go-to source for fast, verified answers and design help — straight from the experts. Search existing answers or ask your own question to get the quick design help you need.

Linked content is provided "AS IS" by the respective contributors. They do not constitute TI specifications and do not necessarily reflect TI's views; see TI's [Terms of Use](#).

12.4 Trademarks

TI E2E™ is a trademark of Texas Instruments.

All trademarks are the property of their respective owners.

12.5 Electrostatic Discharge Caution



This integrated circuit can be damaged by ESD. Texas Instruments recommends that all integrated circuits be handled with appropriate precautions. Failure to observe proper handling and installation procedures can cause damage.

ESD damage can range from subtle performance degradation to complete device failure. Precision integrated circuits may be more susceptible to damage because very small parametric changes could cause the device not to meet its published specifications.

12.6 Glossary

[TI Glossary](#) This glossary lists and explains terms, acronyms, and definitions.

13 Mechanical, Packaging, and Orderable Information

The following pages include mechanical, packaging, and orderable information. This information is the most current data available for the designated devices. This data is subject to change without notice and revision of this document. For browser-based versions of this data sheet, refer to the left-hand navigation.

PACKAGING INFORMATION

Orderable Device	Status (1)	Package Type	Package Drawing	Pins	Package Qty	Eco Plan (2)	Lead finish/ Ball material (6)	MSL Peak Temp (3)	Op Temp (°C)	Device Marking (4/5)	Samples
TPS3760A012DYYR	ACTIVE	SOT-23-THIN	DYY	14	3000	RoHS & Green	NIPDAU	Level-1-260C-UNLIM	-40 to 125	A012	Samples
TPS3760E012DYYR	ACTIVE	SOT-23-THIN	DYY	14	3000	RoHS & Green	NIPDAU	Level-1-260C-UNLIM	-40 to 125	E012	Samples
TPS3760E565DYYR	ACTIVE	SOT-23-THIN	DYY	14	3000	RoHS & Green	NIPDAU	Level-1-260C-UNLIM	-40 to 125	E565	Samples

(1) The marketing status values are defined as follows:

ACTIVE: Product device recommended for new designs.

LIFEBUY: TI has announced that the device will be discontinued, and a lifetime-buy period is in effect.

NRND: Not recommended for new designs. Device is in production to support existing customers, but TI does not recommend using this part in a new design.

PREVIEW: Device has been announced but is not in production. Samples may or may not be available.

OBSOLETE: TI has discontinued the production of the device.

(2) **RoHS:** TI defines "RoHS" to mean semiconductor products that are compliant with the current EU RoHS requirements for all 10 RoHS substances, including the requirement that RoHS substance do not exceed 0.1% by weight in homogeneous materials. Where designed to be soldered at high temperatures, "RoHS" products are suitable for use in specified lead-free processes. TI may reference these types of products as "Pb-Free".

RoHS Exempt: TI defines "RoHS Exempt" to mean products that contain lead but are compliant with EU RoHS pursuant to a specific EU RoHS exemption.

Green: TI defines "Green" to mean the content of Chlorine (Cl) and Bromine (Br) based flame retardants meet JS709B low halogen requirements of <=1000ppm threshold. Antimony trioxide based flame retardants must also meet the <=1000ppm threshold requirement.

(3) MSL, Peak Temp. - The Moisture Sensitivity Level rating according to the JEDEC industry standard classifications, and peak solder temperature.

(4) There may be additional marking, which relates to the logo, the lot trace code information, or the environmental category on the device.

(5) Multiple Device Markings will be inside parentheses. Only one Device Marking contained in parentheses and separated by a "~" will appear on a device. If a line is indented then it is a continuation of the previous line and the two combined represent the entire Device Marking for that device.

(6) Lead finish/Ball material - Orderable Devices may have multiple material finish options. Finish options are separated by a vertical ruled line. Lead finish/Ball material values may wrap to two lines if the finish value exceeds the maximum column width.

Important Information and Disclaimer:The information provided on this page represents TI's knowledge and belief as of the date that it is provided. TI bases its knowledge and belief on information provided by third parties, and makes no representation or warranty as to the accuracy of such information. Efforts are underway to better integrate information from third parties. TI has taken and continues to take reasonable steps to provide representative and accurate information but may not have conducted destructive testing or chemical analysis on incoming materials and chemicals. TI and TI suppliers consider certain information to be proprietary, and thus CAS numbers and other limited information may not be available for release.

In no event shall TI's liability arising out of such information exceed the total purchase price of the TI part(s) at issue in this document sold by TI to Customer on an annual basis.

OTHER QUALIFIED VERSIONS OF TPS3760 :

- Automotive : [TPS3760-Q1](#)

NOTE: Qualified Version Definitions:

- Automotive - Q100 devices qualified for high-reliability automotive applications targeting zero defects

TAPE AND REEL INFORMATION

QUADRANT ASSIGNMENTS FOR PIN 1 ORIENTATION IN TAPE



*All dimensions are nominal

Device	Package Type	Package Drawing	Pins	SPQ	Reel Diameter (mm)	Reel Width W1 (mm)	A0 (mm)	B0 (mm)	K0 (mm)	P1 (mm)	W (mm)	Pin1 Quadrant
TPS3760A012DYYR	SOT-23-THIN	DYY	14	3000	330.0	12.4	4.8	3.6	1.6	8.0	12.0	Q3
TPS3760E012DYYR	SOT-23-THIN	DYY	14	3000	330.0	12.4	4.8	3.6	1.6	8.0	12.0	Q3
TPS3760E565DYYR	SOT-23-THIN	DYY	14	3000	330.0	12.4	4.8	3.6	1.6	8.0	12.0	Q3

TAPE AND REEL BOX DIMENSIONS

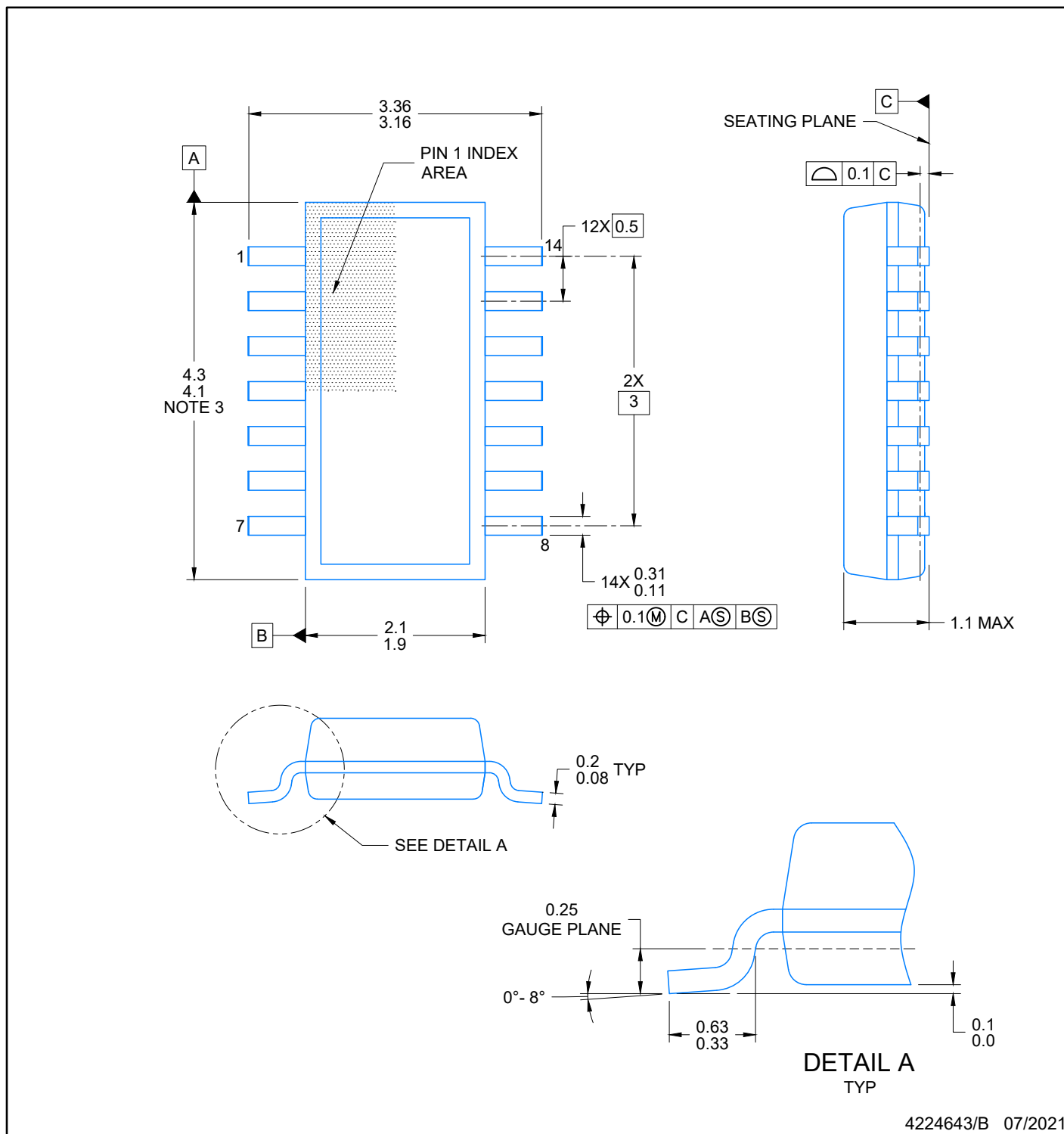

*All dimensions are nominal

Device	Package Type	Package Drawing	Pins	SPQ	Length (mm)	Width (mm)	Height (mm)
TPS3760A012DYYR	SOT-23-THIN	DYY	14	3000	336.6	336.6	31.8
TPS3760E012DYYR	SOT-23-THIN	DYY	14	3000	336.6	336.6	31.8
TPS3760E565DYYR	SOT-23-THIN	DYY	14	3000	336.6	336.6	31.8

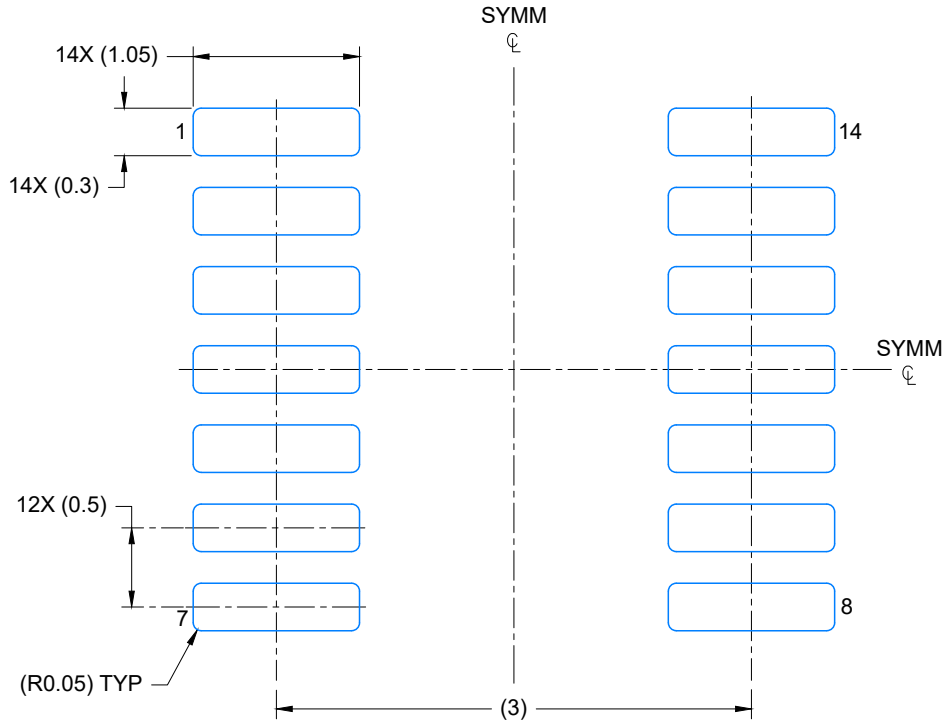

NOTES:

1. All linear dimensions are in millimeters. Any dimensions in parenthesis are for reference only. Dimensioning and tolerancing per ASME Y14.5M.
2. This drawing is subject to change without notice.
3. This dimension does not include mold flash, protrusions, or gate burrs. Mold flash, protrusions, or gate burrs shall not exceed 0.15 per side.
4. This dimension does not include interlead flash. Interlead flash shall not exceed 0.50 per side.
5. Reference JEDEC Registration MO-345, Variation AB



LAND PATTERN EXAMPLE
EXPOSED METAL SHOWN
SCALE: 20X

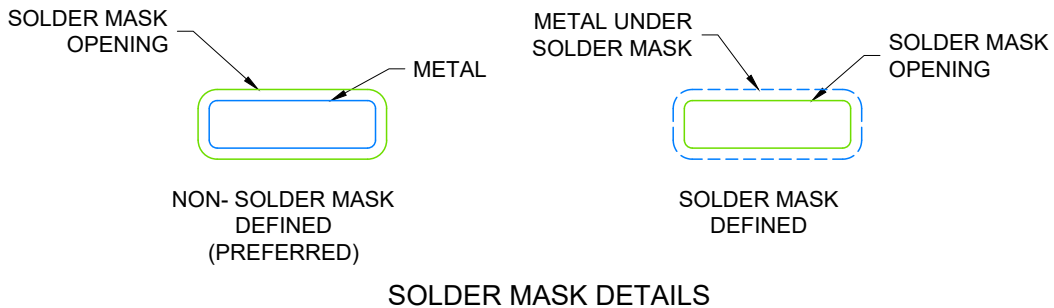

4224643/B 07/2021

NOTES: (continued)

- 6. Publication IPC-7351 may have alternate designs.
- 7. Solder mask tolerances between and around signal pads can vary based on board fabrication site.

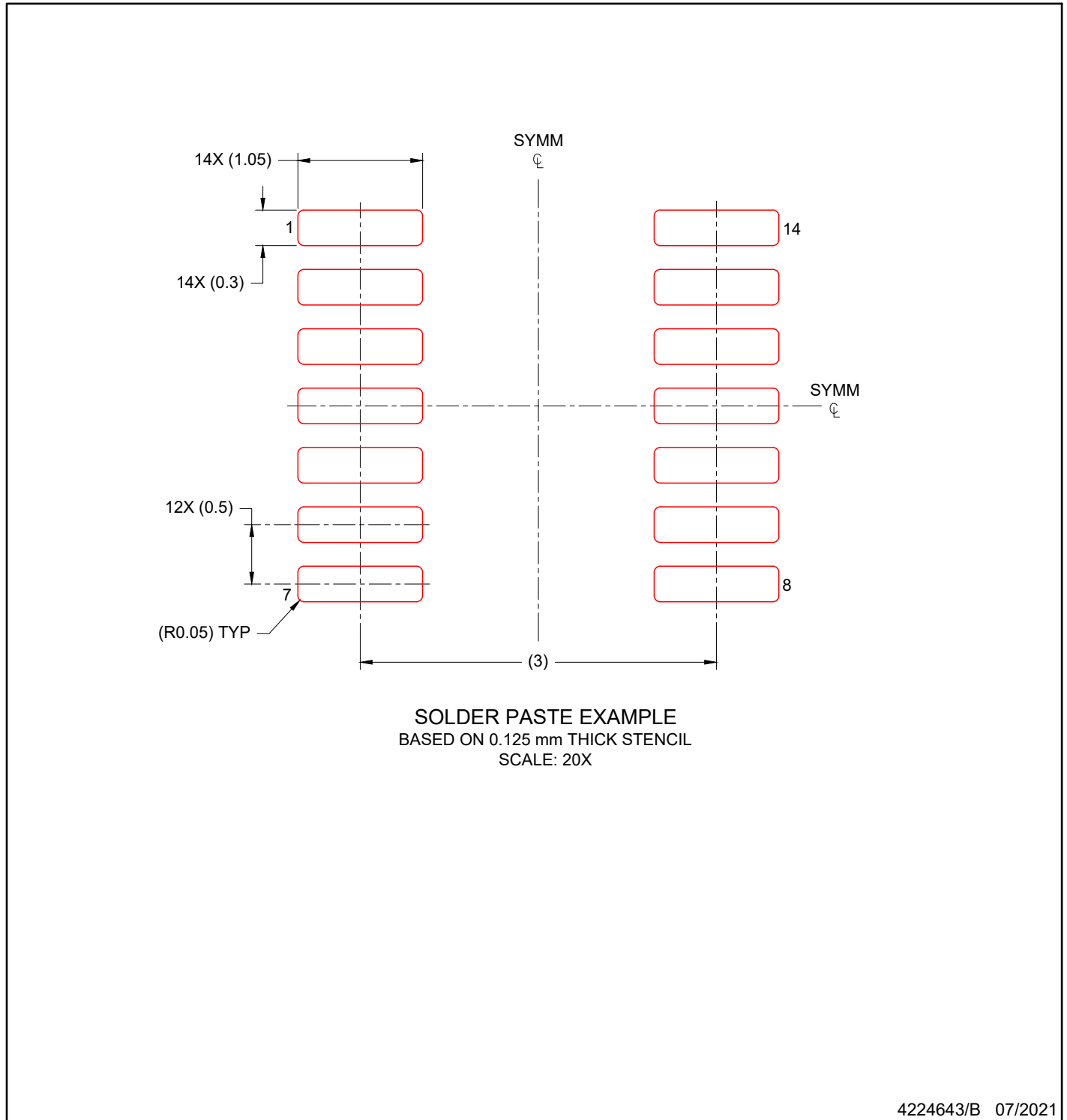

NOTES: (continued)

8. Laser cutting apertures with trapezoidal walls and rounded corners may offer better paste release. IPC-7525 may have alternate design recommendations.
9. Board assembly site may have different recommendations for stencil design.

IMPORTANT NOTICE AND DISCLAIMER

TI PROVIDES TECHNICAL AND RELIABILITY DATA (INCLUDING DATA SHEETS), DESIGN RESOURCES (INCLUDING REFERENCE DESIGNS), APPLICATION OR OTHER DESIGN ADVICE, WEB TOOLS, SAFETY INFORMATION, AND OTHER RESOURCES "AS IS" AND WITH ALL FAULTS, AND DISCLAIMS ALL WARRANTIES, EXPRESS AND IMPLIED, INCLUDING WITHOUT LIMITATION ANY IMPLIED WARRANTIES OF MERCHANTABILITY, FITNESS FOR A PARTICULAR PURPOSE OR NON-INFRINGEMENT OF THIRD PARTY INTELLECTUAL PROPERTY RIGHTS.

These resources are intended for skilled developers designing with TI products. You are solely responsible for (1) selecting the appropriate TI products for your application, (2) designing, validating and testing your application, and (3) ensuring your application meets applicable standards, and any other safety, security, regulatory or other requirements.

These resources are subject to change without notice. TI grants you permission to use these resources only for development of an application that uses the TI products described in the resource. Other reproduction and display of these resources is prohibited. No license is granted to any other TI intellectual property right or to any third party intellectual property right. TI disclaims responsibility for, and you will fully indemnify TI and its representatives against, any claims, damages, costs, losses, and liabilities arising out of your use of these resources.

TI's products are provided subject to [TI's Terms of Sale](#) or other applicable terms available either on [ti.com](https://www.ti.com) or provided in conjunction with such TI products. TI's provision of these resources does not expand or otherwise alter TI's applicable warranties or warranty disclaimers for TI products.

TI objects to and rejects any additional or different terms you may have proposed.

Mailing Address: Texas Instruments, Post Office Box 655303, Dallas, Texas 75265
Copyright © 2023, Texas Instruments Incorporated