

LOW INPUT VOLTAGE SYNCHRONOUS BOOST CONVERTER WITH LOW QUIESCENT CURRENT

Check for Samples: [TPS61097](#)

FEATURES

- Up to 95% Efficiency at Typical Operating Conditions
- Connection from Battery to Load via Bypass Switch in Shutdown Mode
- Typical Shutdown Current Less Than 5 nA
- Typical Quiescent Current Less Than 5 μ A
- Operating Input Voltage Range From 0.9 V to 5.5 V
- Power-Save Mode for Improved Efficiency at Low Output Power
- Overtemperature Protection
- Small 2.8-mm x 2.9-mm 5-Pin SOT-23 Package (6-Pin for Adjustable)

APPLICATIONS

- MSP430 Applications
- All Single-Cell, Two-Cell, and Three-Cell Alkaline, NiCd, NiMH, or Single-Cell Li-Battery Powered Products
- Personal Medical Products
- Fuel Cell and Solar Cell Powered Products
- PDAs
- Mobile Applications
- White LEDs

DESCRIPTION

The TPS61097 provide a power supply solution for products powered by either a single-cell, two-cell, or three-cell alkaline, NiCd, or NiMH, or one-cell Li-Ion or Li-polymer battery. They can also be used in fuel cell or solar cell powered devices where the capability of handling low input voltages is essential. Possible output currents depend on the input-to-output voltage ratio. The devices provides output currents up to 100 mA at a 3.3-V output while using a single-cell Li-Ion or Li-Polymer battery. The boost converter is based on a current-mode controller using synchronous rectification to obtain maximum efficiency. The maximum average input current is limited to a value of 350 mA. The output voltage can be programmed by an external resistor divider, or it is fixed internally on the chip. The converter can be disabled to minimize battery drain. During shutdown, the battery is connected to the load to enable battery backup of critical functions on the load. The fixed output device is packaged in a 5-pin SOT-23 package (DBV) measuring 2.8 mm \times 2.9 mm.

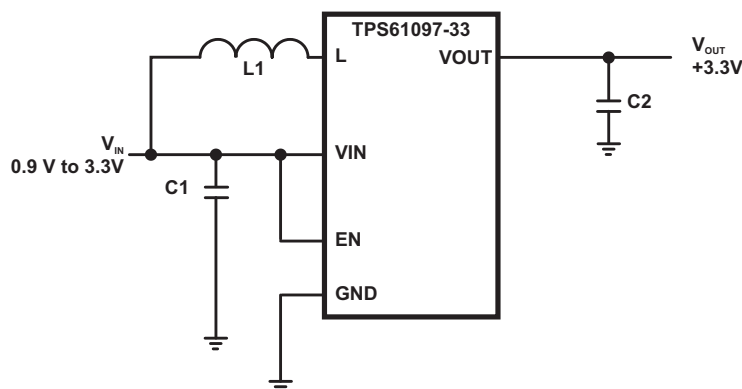

Please be aware that an important notice concerning availability, standard warranty, and use in critical applications of Texas Instruments semiconductor products and disclaimers thereto appears at the end of this data sheet.

ORDERING INFORMATION ⁽¹⁾ ⁽²⁾

T_A	PACKAGE ⁽³⁾	ORDERABLE PART NUMBER	TOP-SIDE MARKING
-40°C to 85°C	5-pin SOT-23 – DBV	Reel of 3000	TPS61097-33DBVR
		Reel of 250	TPS61097-33DBVT
			NFSK

- (1) For the most current package and ordering information, see the Package Option Addendum at the end of this document, or see the TI web site at www.ti.com.
- (2) Contact the factory for availability of other fixed output voltage versions.
- (3) Package drawings, thermal data, and symbolization are available at www.ti.com/packaging.

ABSOLUTE MAXIMUM RATINGS

over operating free-air temperature range (unless otherwise noted)⁽¹⁾

V_I	Input voltage range	VIN, L, VOUT, EN, FB	-0.3 V to 7 V
I_{sc}	Short-circuit current		400 mA
T_J	Junction temperature range		-40°C to 150°C
T_{stg}	Storage temperature range		-65°C to 150°C
ESD	Electrostatic discharge rating	Human-Body Model (HBM) ⁽²⁾	2000 V

- (1) Stresses beyond those listed under *Absolute Maximum Ratings* may cause permanent damage to the device. These are stress ratings only, and functional operation of the device at these or any other conditions beyond those indicated under *Recommended Operating Conditions* is not implied. Exposure to absolute-maximum-rated conditions for extended periods may affect device reliability.
- (2) ESD testing is performed according to the respective JEDEC standard.

DISSIPATION RATINGS TABLE

PACKAGE	THERMAL RESISTANCE θ_{JA}	POWER RATING $T_A \leq 25^\circ\text{C}$	DERATING FACTOR ABOVE $T_A = 25^\circ\text{C}$
DBV	255°C/W	390 mW	-3.92 mW/°C

RECOMMENDED OPERATING CONDITIONS

		MIN	MAX	UNIT
V_{IN}	Supply voltage at VIN	0.9	5.5	V
V_{OUT}	Adjustable output voltage	1.8	5.5	V
T_A	Operating free air temperature range	-40	85	°C
T_J	Operating junction temperature range	-40	125	°C

ELECTRICAL CHARACTERISTICS

over recommended free-air temperature range and over recommended input voltage range (typical at an ambient temperature range of 25°C) (unless otherwise noted)

DC/DC STAGE							
PARAMETER		TEST CONDITIONS	MIN	TYP	MAX	UNIT	
V_{IN}	Input voltage		0.9		5.5	V	
V_{OUT}	TPS61097-33	$V_{IN} = 1.2\text{ V}$, $I_{OUT} = 10\text{ mA}$	3.20	3.30	3.40	V	
I_{SW}	Switch current limit	$V_{OUT} = 3.3\text{ V}$	200	350	475	mA	
	Rectifying switch on resistance	$V_{OUT} = 3.3\text{ V}$		1.0		Ω	
	Main switch on resistance	$V_{OUT} = 3.3\text{ V}$		1.0		Ω	
	Bypass switch on resistance	$V_{IN} = 1.2\text{ V}$, $I_{OUT} = 100\text{ mA}$		3.4		Ω	
	Line regulation	$V_{IN} < V_{OUT}$, $V_{IN} = 1.2\text{ V}$ to 1.8 V , $I_{OUT} = 10\text{ mA}$		0.5%			
	Load regulation	$V_{IN} < V_{OUT}$, $I_{OUT} = 10\text{ mA}$ to 50 mA , $V_{IN} = 1.8\text{ V}$		0.5%			
I_Q	Quiescent current	V_{IN}	$I_O = 0\text{ mA}$, $V_{EN} = V_{IN} = 1.2\text{ V}$, $V_{OUT} = 3.4\text{ V}$		1	2.5	μA
		V_{OUT}			4	6.5	μA
I_{SD}	Shutdown current	V_{IN}	$V_{EN} = 0\text{ V}$, $V_{IN} = 1.2\text{ V}$, $I_{OUT} = 0\text{ mA}$		0.005	0.15	μA
		V_{IN}			$V_{EN} = 0\text{ V}$, $V_{IN} = 3\text{ V}$, $I_{OUT} = 0\text{ mA}$		
	Leakage current into L	$V_{EN} = 0\text{ V}$, $V_{IN} = 1.2\text{ V}$, $V_L = 1.2\text{ V}$		0.01	1	μA	

CONTROL STAGE						
PARAMETER		TEST CONDITIONS	MIN	TYP	MAX	UNIT
	EN input current	$EN = 0\text{ V}$ or $EN = V_{IN}$		0.01	0.1	μA
V_{IL}	Logic low level, EN falling edge				0.65	V
V_{IH}	Logic high level, EN rising edge		0.78		$V_{IN} + 1.0\text{ V}$	V
	Overtemperature protection			150		$^{\circ}\text{C}$
	Overtemperature hysteresis			20		$^{\circ}\text{C}$
VUVLO	Undervoltage lock-out threshold for turn off	V_{IN} decreasing		0.5	0.7	

PIN ASSIGNMENTS

FIXED OUTPUT VOLTAGE
DBV PACKAGE
(TOP VIEW)

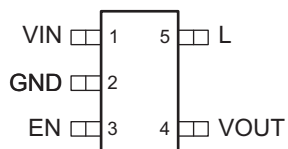

Terminal Functions

TERMINAL		I/O	DESCRIPTION
NAME	NO. Fixed		
VIN	1	I	Boost converter input voltage
GND	2		Control / logic ground
EN	3	I	Enable input (1 = enabled, 0 = disabled). EN must be actively terminated high or low.
VOUT	4	O	Boost converter output
L	5	I	Connection for inductor
FB	–	I	Voltage feedback

FUNCTIONAL BLOCK DIAGRAM (FIXED OUTPUT VERSION)

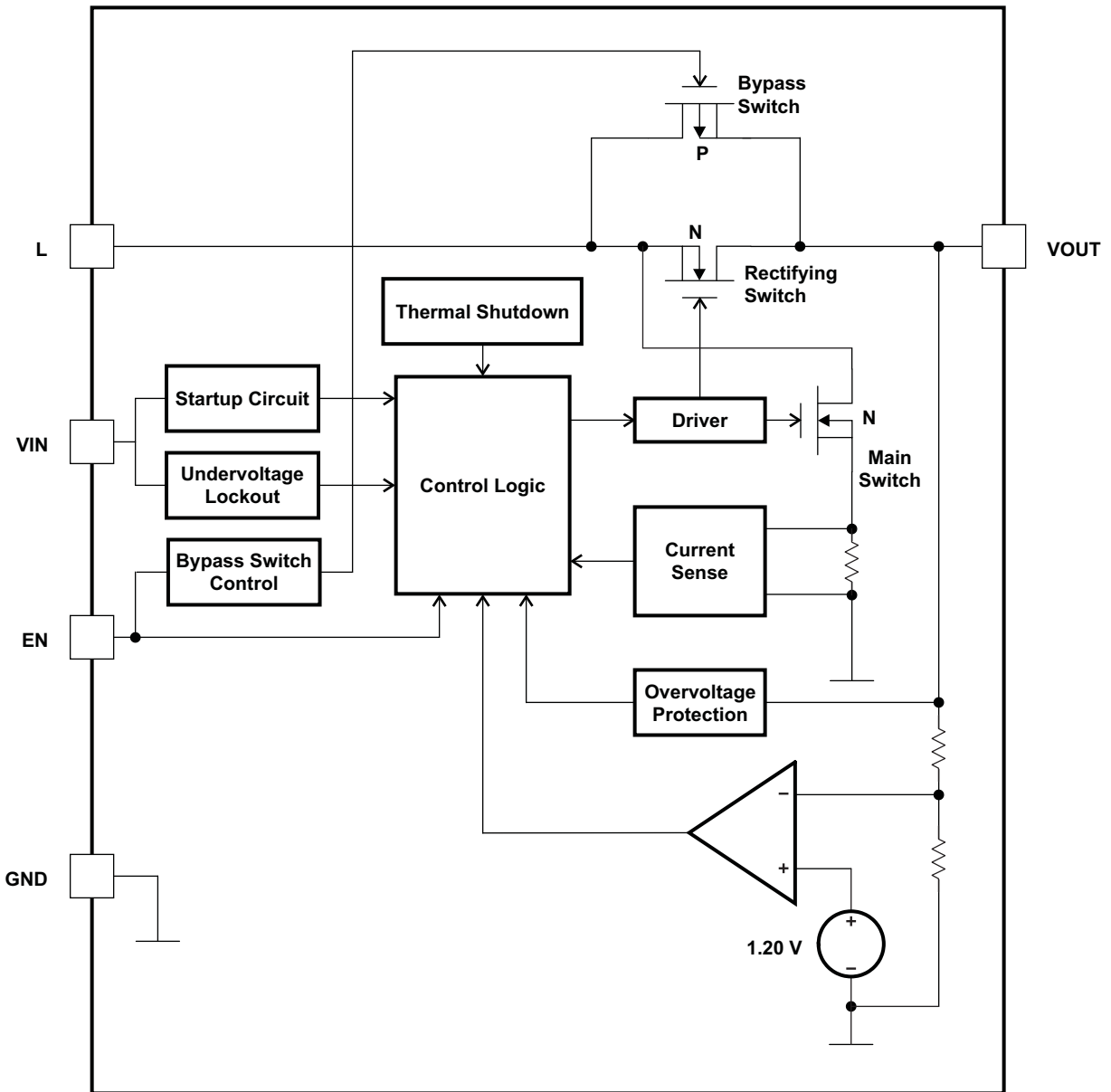

PARAMETER MEASUREMENT INFORMATION

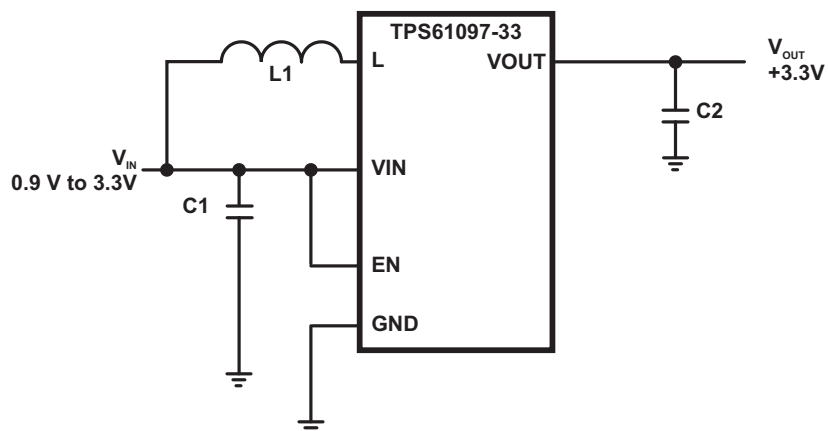

C1	10 μ F
C2	10 μ F
L	10 μ H

Table 1. List of Components

REFERENCE	MANUFACTURER	PART NO.
C1	Murata	GRM319R61A106KE19 10 μ F 10V X5R 1206 20%
C2	Murata	GRM319R61A106KE19 10 μ F 10V X5R 1206 20%
L1	Coilcraft	DO3314-103MLC

TYPICAL CHARACTERISTICS

Table 2. Table of Graphs

		FIGURE
Maximum Output Current	vs Input Voltage	1
Efficiency	vs Output Current	2
	vs Input Voltage	3
Input Current	vs Input Voltage (Device Enabled, No Output Load, $V_{OUT} = 3.3\text{ V}$)	4
	vs Input Voltage (Device Disabled, No Output Load)	5
Startup Voltage	vs Temperature	6
	vs Output Current	7
Output Voltage	vs Output Current	8
	vs Input Voltage	9
Waveforms	Output Voltage Ripple	10
	Load Transient Response	11
	Line Transient Response	12
	Switching Waveform, Continuous Mode	13
	Switching Waveform, Discontinuous Mode	14
	Startup After Enable ($V_{IN} = 1.2\text{ V}$, $I_{OUT} = 10\text{ mA}$)	15
	Startup After Enable ($V_{IN} = 1.8\text{ V}$, $I_{OUT} = 10\text{ mA}$)	16

MAXIMUM OUTPUT CURRENT
vs
INPUT VOLTAGE

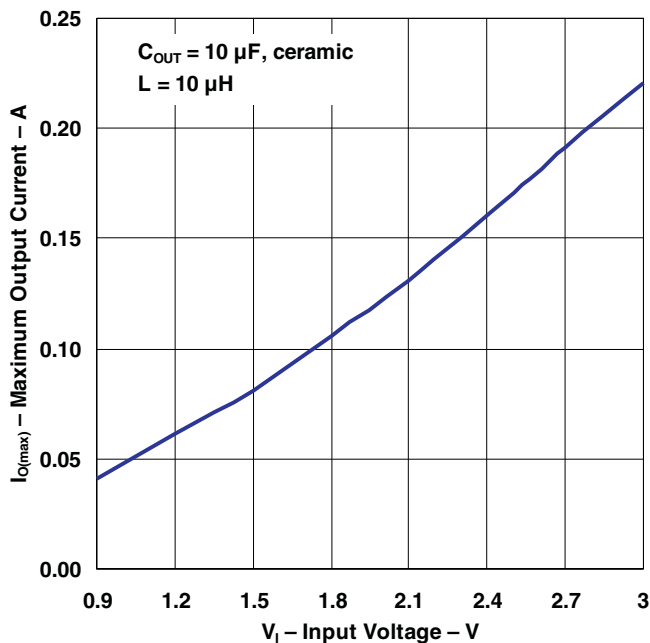

Figure 1.

EFFICIENCY
vs
OUTPUT CURRENT

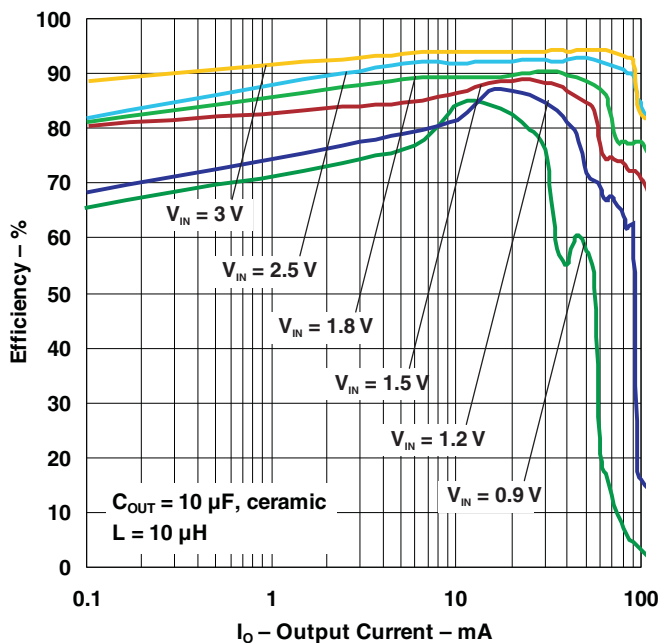
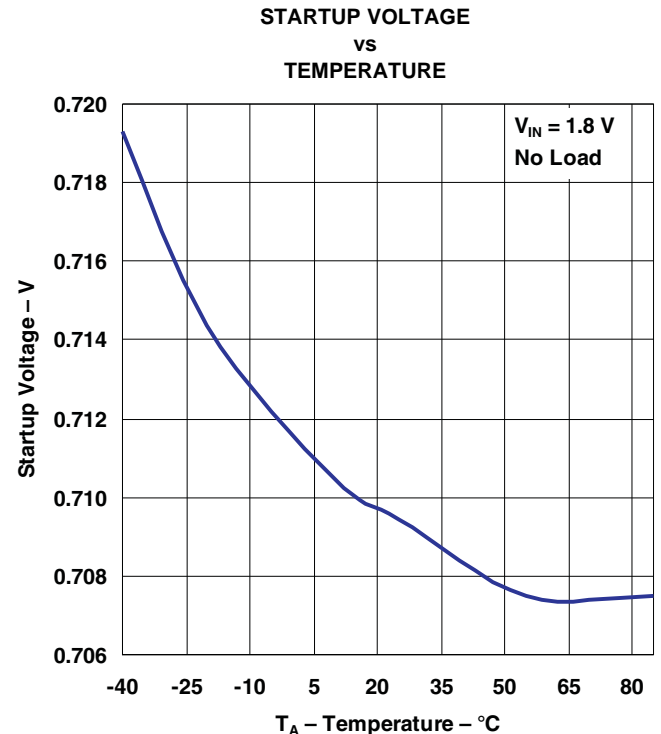
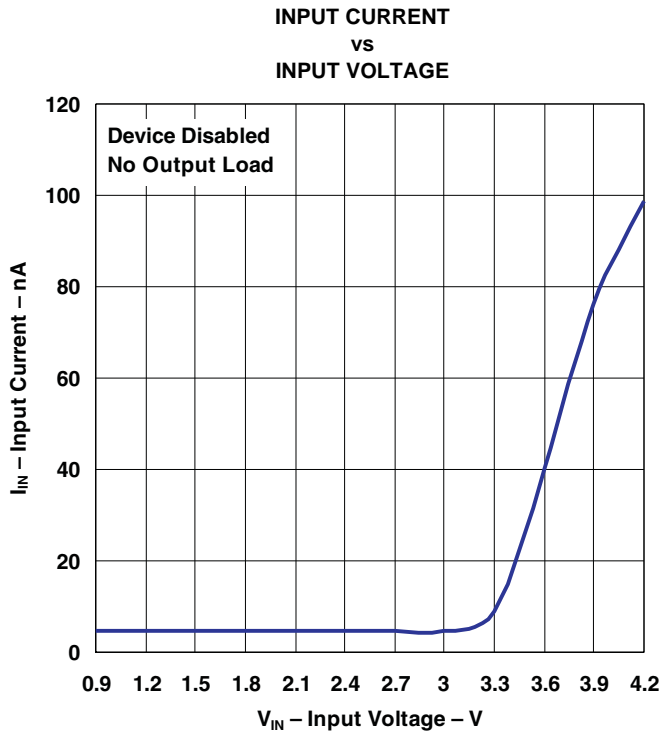
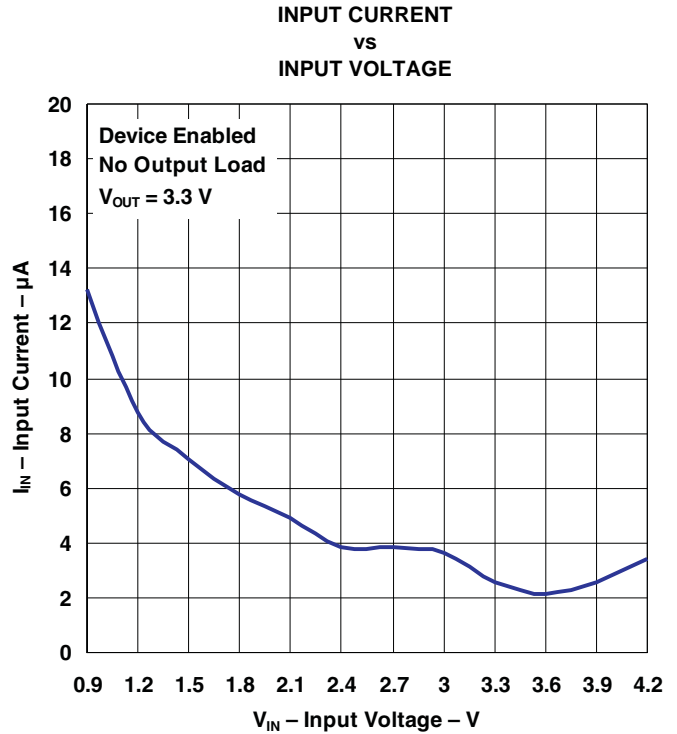
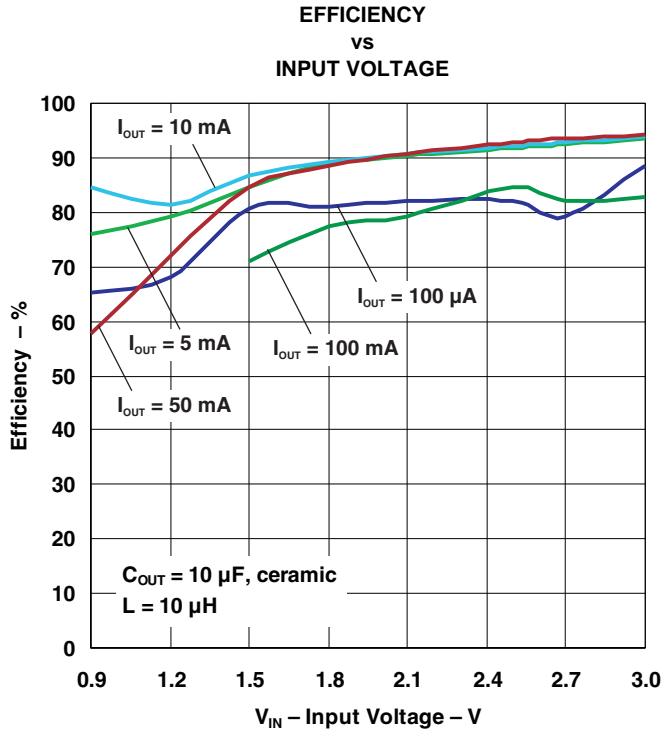

Figure 2.



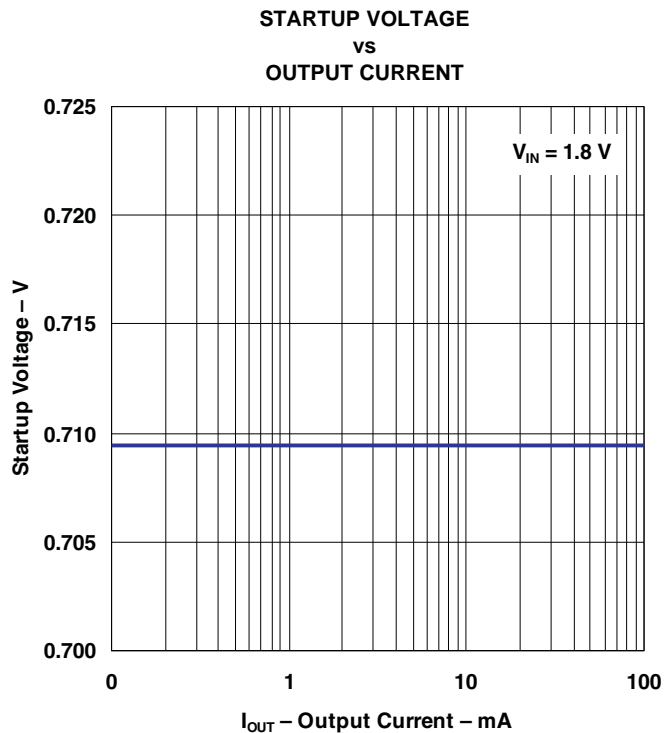

Figure 7.

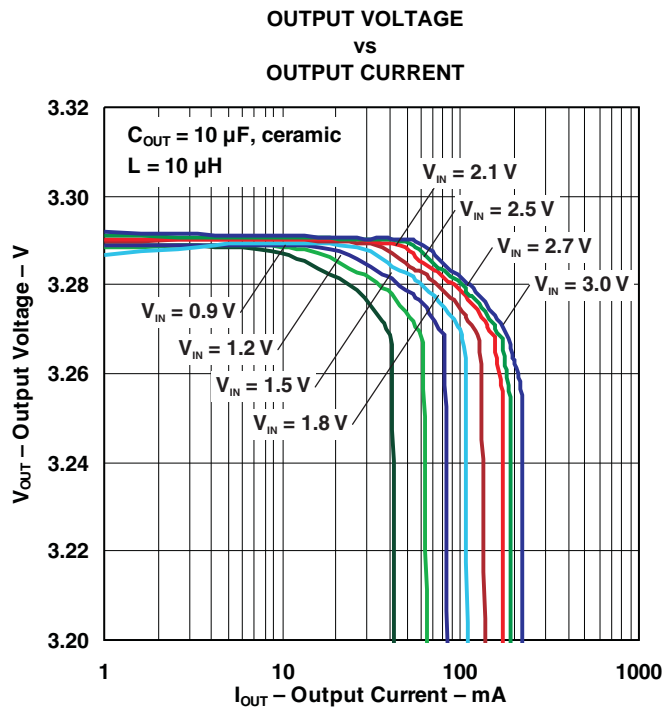

Figure 8.

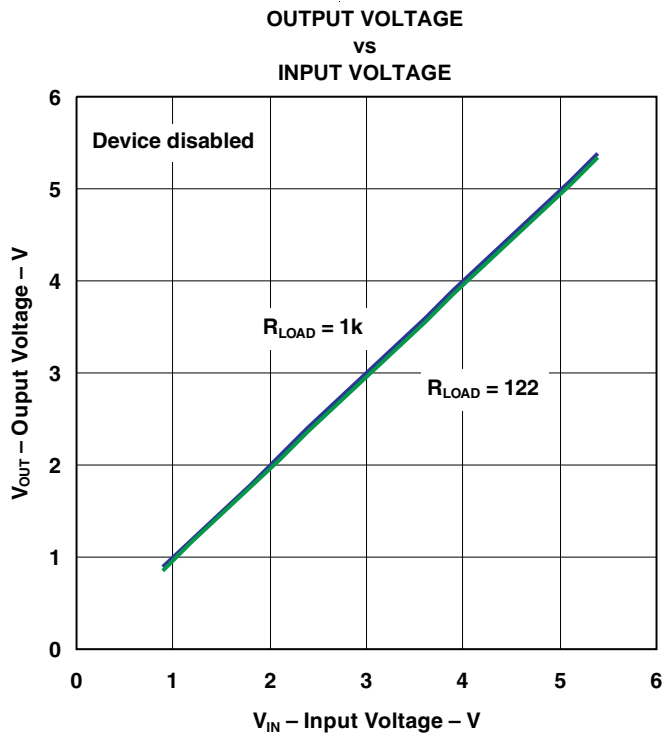

Figure 9.

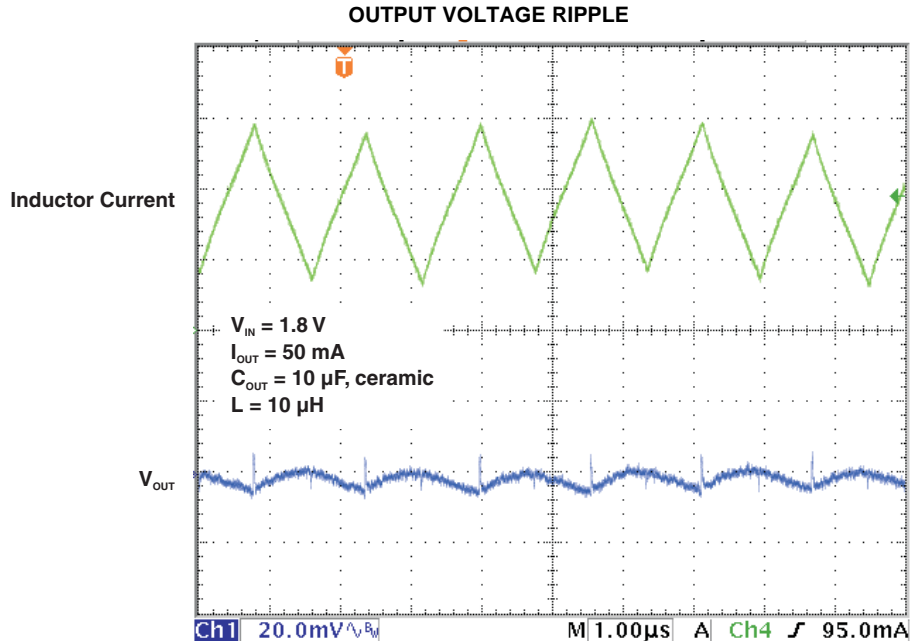

Figure 10.

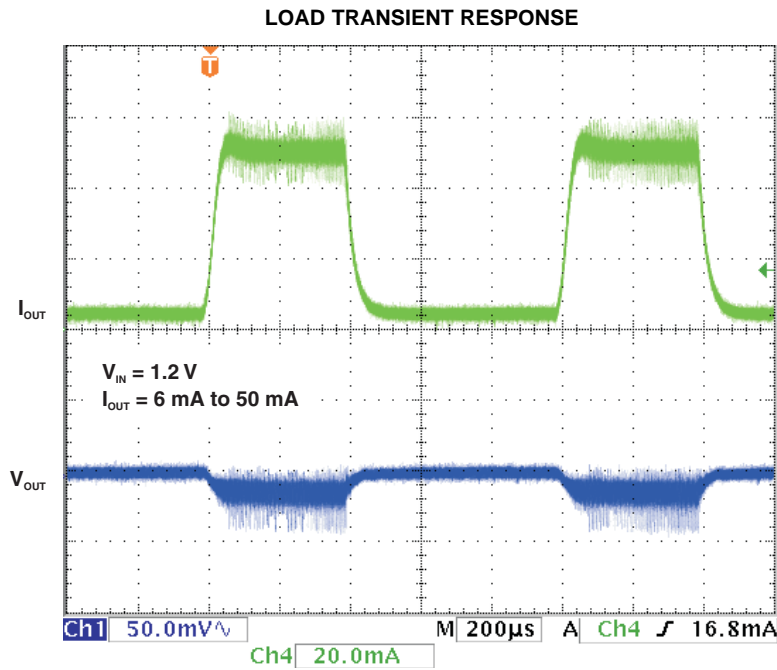

Figure 11.

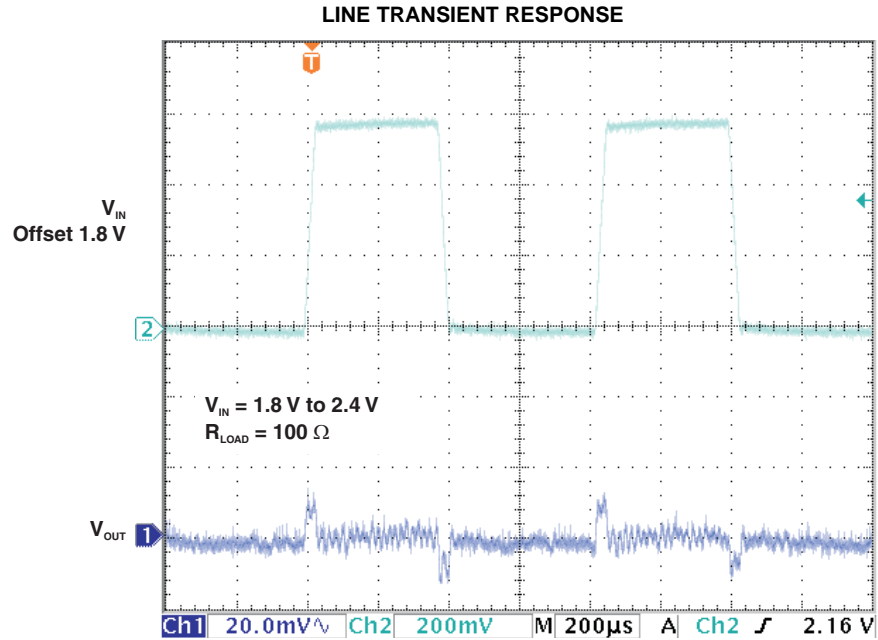

Figure 12.

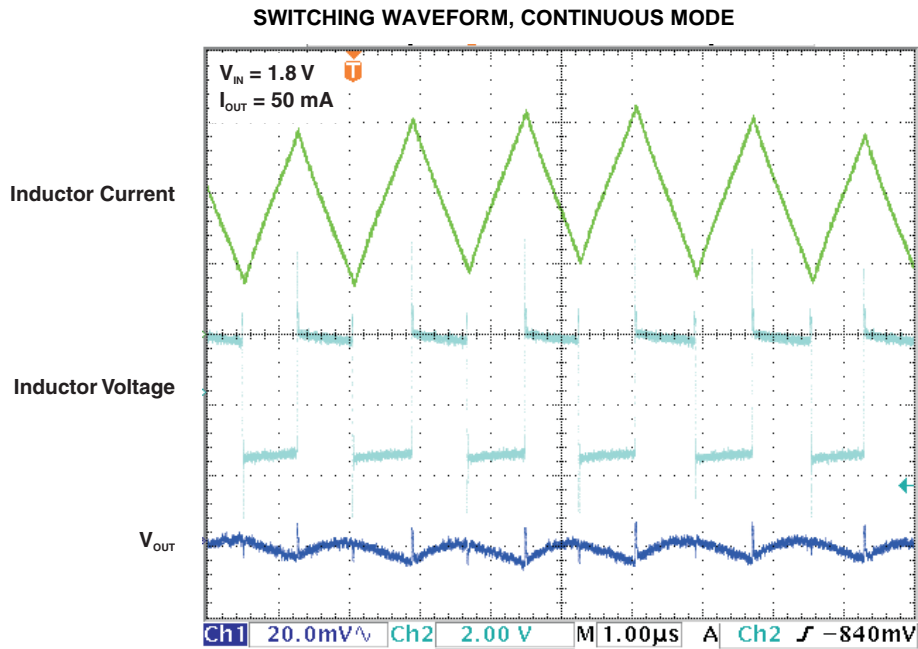

Figure 13.

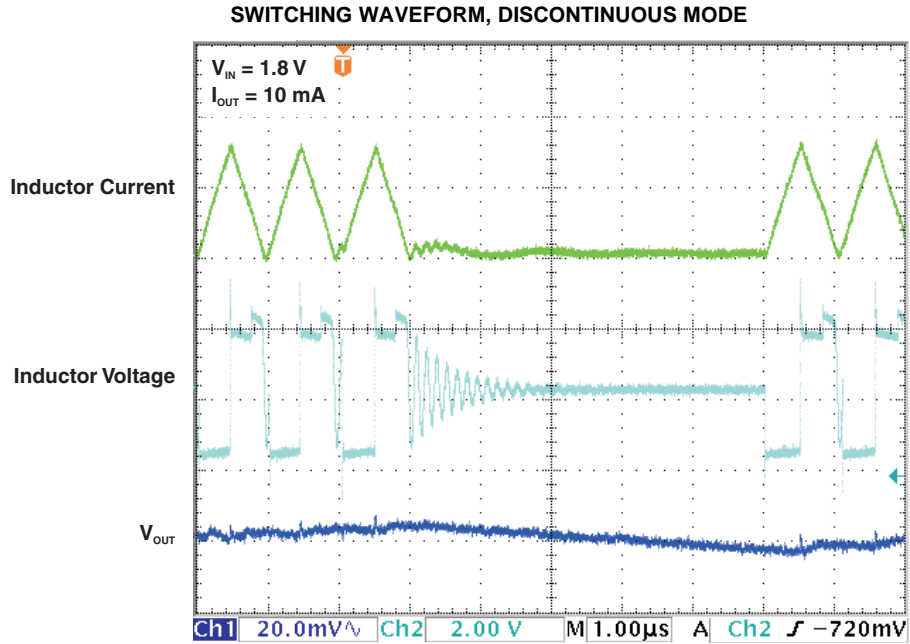

Figure 14.

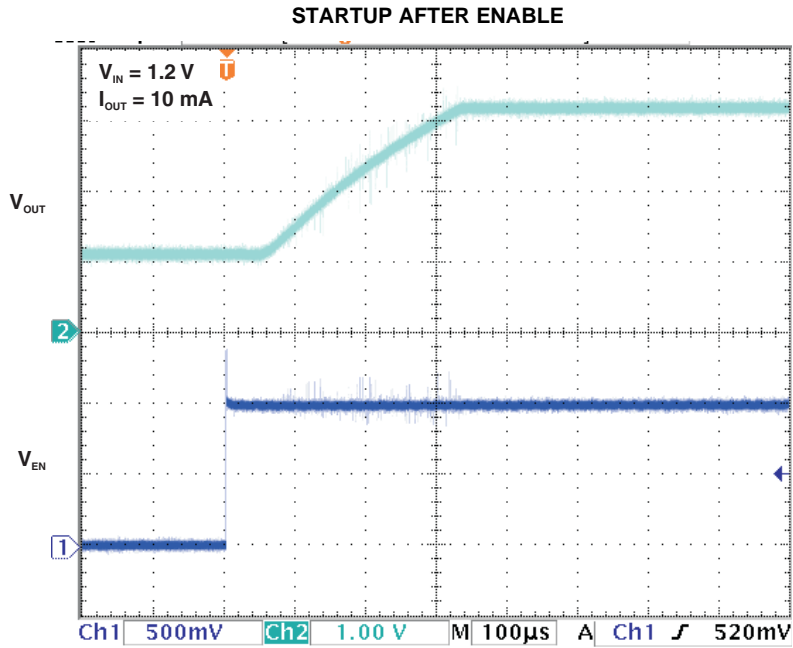

Figure 15.

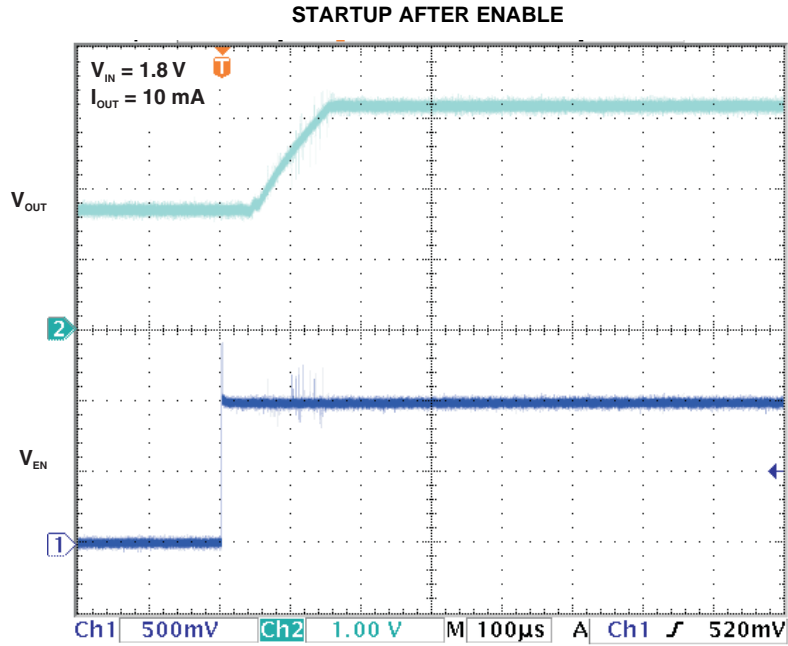

Figure 16.

DETAILED DESCRIPTION

Operation

The TPS61097 is a high performance, high efficient family of switching boost converters. To achieve high efficiency the power stage is realized as a synchronous boost topology. For the power switching two actively controlled low R_{DSon} power MOSFETs are implemented.

Controller Circuit

The device is controlled by a hysteretic current mode controller. This controller regulates the output voltage by keeping the inductor ripple current constant in the range of 200 mA and adjusting the offset of this inductor current depending on the output load. If the required average input current is lower than the average inductor current defined by this constant ripple the inductor current goes discontinuous to keep the efficiency high at low load conditions.

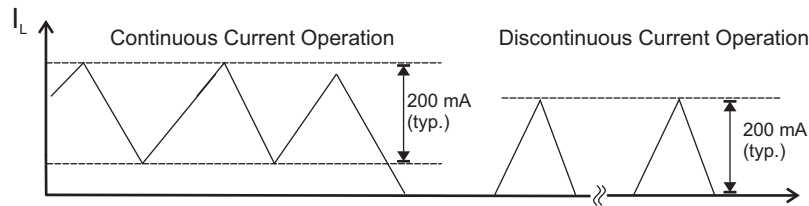

Figure 17. Hysteretic Current Operation

The output voltage V_{OUT} is monitored via the feedback network which is connected to the voltage error amplifier. To regulate the output voltage, the voltage error amplifier compares this feedback voltage to the internal voltage reference and adjusts the required offset of the inductor current accordingly. For fixed output voltage versions, the feedback function is connected internally. A resistive divider network is required to set the output voltage with the adjustable option.

The self oscillating hysteretic current mode architecture is inherently stable and allows fast response to load variations. It also allows using inductors and capacitors over a wide value range.

Device Enable and Shutdown Mode

The device is enabled when EN is set high and shut down when EN is low. During shutdown, the converter stops switching and all internal control circuitry is turned off.

Bypass Switch

The TPS61097 contains a P-channel MOSFET (Bypass Switch) in parallel with the synchronous rectifying MOSFET. When the IC is enabled ($EN = V_{IH}$), the Bypass Switch is turned off to allow the IC to work as a standard boost converter. When the IC is disabled ($EN = V_{IL}$) the Bypass Switch is turned on to provide a direct, low impedance connection from the input voltage (at the L pin) to the load (V_{OUT}). The Bypass Switch is not impacted by Undervoltage lockout, Overvoltage or Thermal shutdown.

Startup

After the EN pin is tied high, the device starts to operate. If the input voltage is not high enough to supply the control circuit properly a startup oscillator starts to operate the switches. During this phase the switching frequency is controlled by the oscillator and the maximum switch current is limited. As soon as the device has built up the output voltage to about 1.8 V, high enough for supplying the control circuit, the device switches to its normal hysteretic current mode operation. The startup time depends on input voltage and load current.

Operation at Output Overload

If in normal boost operation the inductor current reaches the internal switch current limit threshold the main switch is turned off to stop further increase of the input current.

In this case the output voltage will decrease since the device can not provide sufficient power to maintain the set output voltage.

If the output voltage drops below the input voltage the backgate diode of the rectifying switch gets forward biased and current starts flow through it. Because this diode cannot be turned off, the load current is only limited by the remaining DC resistances. As soon as the overload condition is removed, the converter automatically resumes normal operation and enters the appropriate soft start mode depending on the operating conditions.

Undervoltage Lockout

An undervoltage lockout function stops the operation of the converter if the input voltage drops below the typical undervoltage lockout threshold. This function is implemented in order to prevent malfunctioning of the converter. The undervoltage lockout function has no control of the Bypass Switch. If the Bypass Switch is enabled ($EN = V_{IL}$) there is no impact during an undervoltage condition, the Bypass Switch remains on.

Overtemperature Protection

The device has a built-in temperature sensor which monitors the internal IC temperature. If the temperature exceeds the programmed threshold (150 °C typical), the device stops operating. As soon as the IC temperature has decreased below the programmed threshold, it starts operating again. There is a built-in hysteresis to avoid unstable operation at IC temperatures at the overtemperature threshold.

APPLICATION INFORMATION

Design Procedure

The TPS61097 DC/DC converters are intended for systems powered by a single up to triple cell Alkaline, NiCd, NiMH battery with a typical terminal voltage between 0.9 V and 5.5 V. They can also be used in systems powered by one-cell Li-Ion or Li-Polymer with a typical voltage between 2.5 V and 4.2 V. Additionally, any other voltage source like solar cells or fuel cells with a typical output voltage between 0.9 V and 5.5 V can power systems where the TPS61097 is used. The TPS61097 does not down-regulate V_{IN} ; therefore, if V_{IN} is greater than V_{OUT} , V_{OUT} tracks V_{IN} .

Adjustable Bypass Switching

The EN pin can be set up as a low voltage control for the bypass switch. By setting the desired ratio of R1 and R2, the TPS61097 can be set to switch on the bypass at a defined voltage level on V_{IN} . For example, setting R1 and R2 to 200K Ω would set V_{EN} to half of V_{IN} . The voltage level of V_{IN} engaging the bypass switch is based on the V_{IL} level of EN (0.65 V). If V_{IN} is less than 1.30 V then the bypass switch will be enabled. For V_{IN} values above 1.50 V (50% of V_{IH}) the bypass switch is disabled.

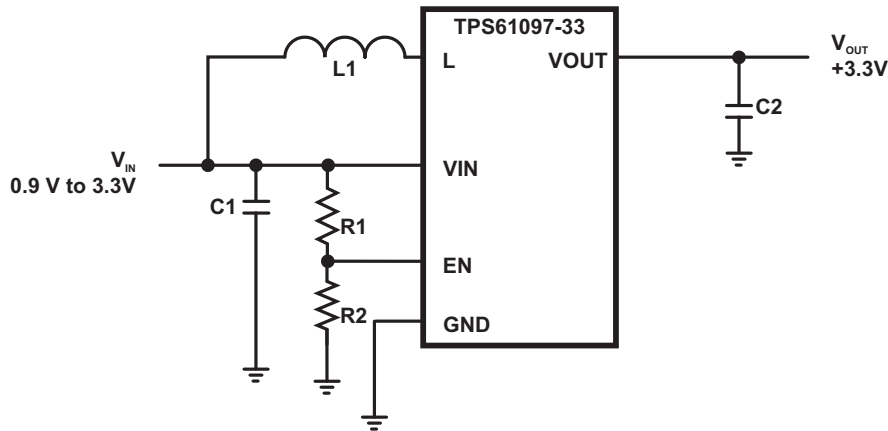

Figure 18. Adjustable Bypass Switching

Inductor Selection

To make sure that the TPS61097 devices can operate, a suitable inductor must be connected between pin VIN and pin L. Inductor values of 4.7 μH show good performance over the whole input and output voltage range .

Choosing other inductance values affects the switching frequency f proportional to $1/L$ as shown in [Equation 1](#).

$$L = \frac{1}{f \times 200 \text{ mA}} \times \frac{V_{IN} \times (V_{OUT} - V_{IN})}{V_{OUT}} \quad (1)$$

Choosing inductor values higher than 4.7 μH can improve efficiency due to reduced switching frequency and therefore with reduced switching losses. Using inductor values below 2.2 μH is not recommended.

Having selected an inductance value, the peak current for the inductor in steady state operation can be calculated. [Equation 2](#) gives the peak current estimate.

$$I_{L,MAX} = \begin{cases} \frac{V_{OUT} \times I_{OUT}}{0.8 \times V_{IN}} + 100 \text{ mA}; & \text{continuous current operation} \\ 200 \text{ mA}; & \text{discontinuous current operation} \end{cases} \quad (2)$$

$I_{L,MAX}$ is the inductor's required minimum current rating. Note that load transient or over current conditions may require an even higher current rating.

Equation 3 provides an easy way to estimate whether the device is operating in continuous or discontinuous operation. As long as the equation is true, continuous operation is typically established. If the equation becomes false, discontinuous operation is typically established.

$$\frac{V_{OUT} \times I_{OUT}}{V_{IN}} > 0.8 \times 100 \text{ mA} \quad (3)$$

Due to the use of current hysteretic control in the TPS61097, the series resistance of the inductor can impact the operation of the main switch. There is a simple calculation that can ensure proper operation of the TPS61097 boost converter. The relationship between the series resistance (R_{IN}), the input voltage (V_{IN}) and the switch current limit (I_{SW}) is shown in Equation 4.

$$R_{IN} < V_{IN} / I_{SW} \quad (4)$$

Examples:

$$I_{SW} = 400 \text{ mA}, V_{IN} = 2.5 \text{ V} \quad (5)$$

In Equation 5, $R_{IN} < 2.5 \text{ V} / 400 \text{ mA}$; therefore, R_{IN} must be less than 6.25 Ω .

$$I_{SW} = 400 \text{ mA}, V_{IN} = 1.8 \text{ V} \quad (6)$$

In Equation 6, $R_{IN} < 1.8 \text{ V} / 400 \text{ mA}$; therefore, R_{IN} must be less than 4.5 Ω .

The following inductor series from different suppliers have been used with TPS61097 converters:

Table 3. List of Inductors

VENDOR	INDUCTOR SERIES
Coilcraft	DO3314
TDK	NLC565050T
Taiyo Yuden	CBC2012T

Capacitor Selection

Input Capacitor

The input capacitor should be at least 10- μF to improve transient behavior of the regulator and EMI behavior of the total power supply circuit. The input capacitor should be a ceramic capacitor and be placed as close as possible to the VIN and GND pins of the IC.

Output Capacitor

For the output capacitor C_2 , it is recommended to use small ceramic capacitors placed as close as possible to the VOUT and GND pins of the IC. If, for any reason, the application requires the use of large capacitors which can not be placed close to the IC, the use of a small ceramic capacitor with an capacitance value of around 2.2 μF in parallel to the large one is recommended. This small capacitor should be placed as close as possible to the VOUT and GND pins of the IC.

A minimum capacitance value of 4.7 μF should be used, 10 μF are recommended. If the inductor value exceeds 4.7 μH , the value of the output capacitance value needs to be half the inductance value or higher for stability reasons, see Equation 7.

$$C_2 \geq \frac{L}{2} \times \frac{\mu\text{F}}{\mu\text{H}} \quad (7)$$

The TPS61097 is not sensitive to the ESR in terms of stability. Using low ESR capacitors, such as ceramic capacitors, is recommended to minimize output voltage ripple. If heavy load changes are expected, the output capacitor value should be increased to avoid output voltage drops during fast load transients.

Table 4. Recommended Output Capacitors

VENDOR	CAPACITOR SERIES
Murata	GRM188R60J106M47D 10 μ F 6.3V X5R 0603
Murata	GRM319R61A106KE19 10 μ F 10V X5R 1206

Layout Considerations

As for all switching power supplies, the layout is an important step in the design, especially at high peak currents and high switching frequencies. If the layout is not carefully done, the regulator could show stability problems as well as EMI problems. Therefore, use wide and short traces for the main current path and for the power ground tracks. The input and output capacitor, as well as the inductor should be placed as close as possible to the IC. Use a common ground node for power ground and a different one for control ground to minimize the effects of ground noise. Connect these ground nodes at any place close to one of the ground pins of the IC.

The feedback divider should be placed as close as possible to the control ground pin of the IC. To lay out the control ground, it is recommended to use short traces as well, separated from the power ground traces. This avoids ground shift problems, which can occur due to superimposition of power ground current and control ground current.

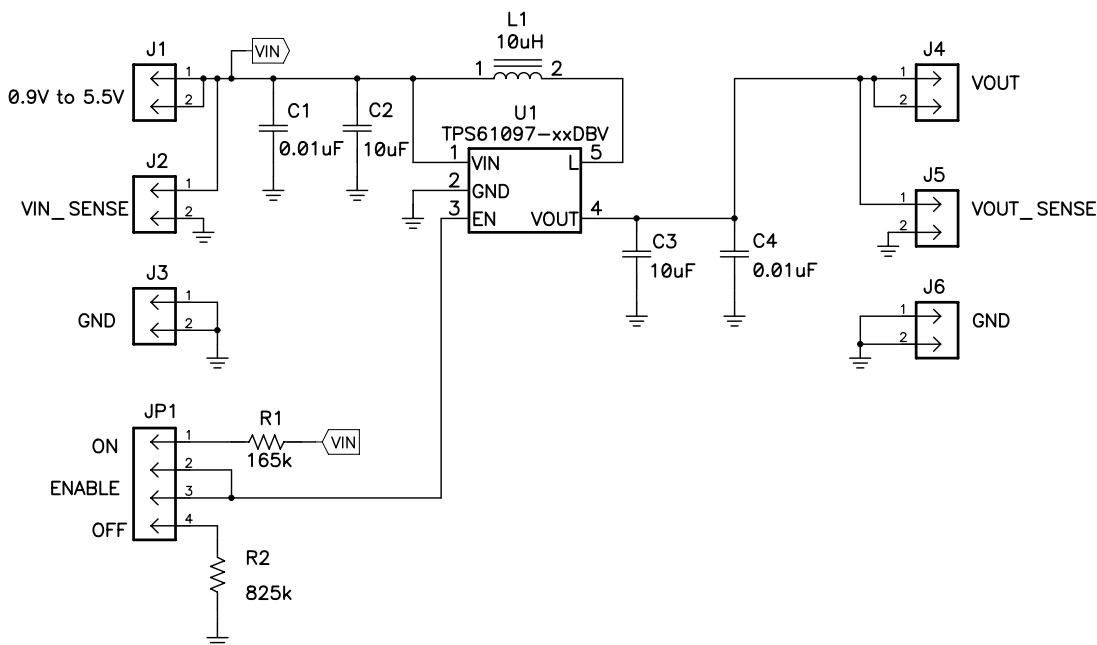

Figure 19. Layout Schematic

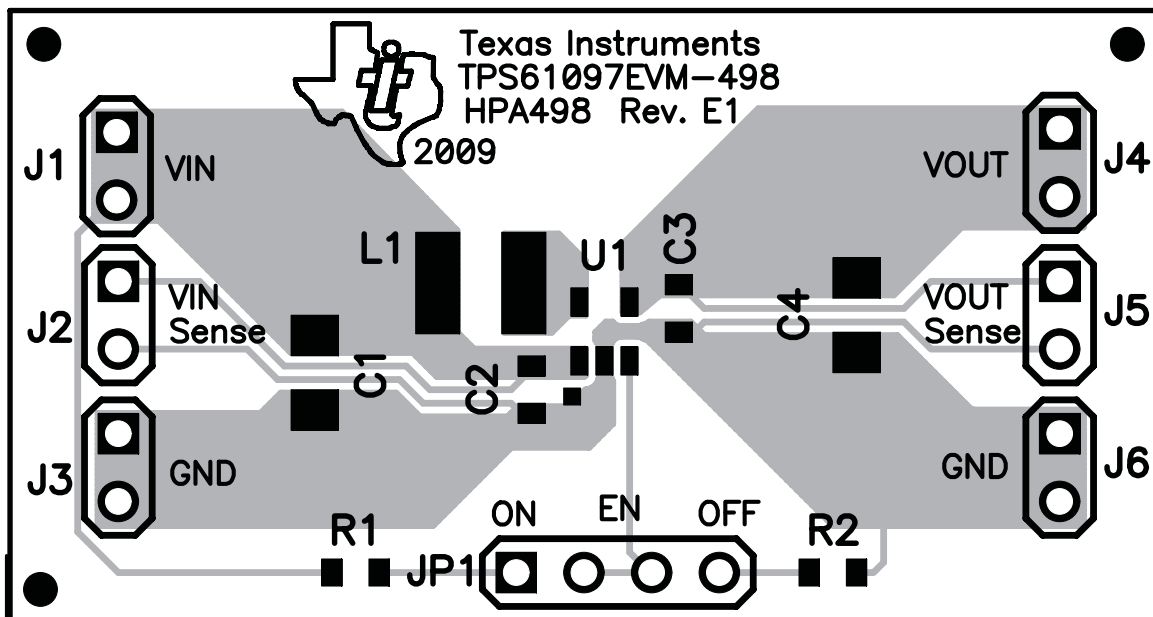

Figure 20. PCB Top View

Thermal Information

Implementation of integrated circuits in low-profile and fine-pitch surface-mount packages typically requires special attention to power dissipation. Many system-dependent issues such as thermal coupling, airflow, added heat sinks and convection surfaces, and the presence of other heat-generating components affect the power-dissipation limits of a given component.

Three basic approaches for enhancing thermal performance are listed below.

- Improving the power dissipation capability of the PCB design
- Improving the thermal coupling of the component to the PCB
- Introducing airflow in the system

The maximum recommended junction temperature (T_J) of the TPS61097 devices is 125°C. Specified regulator operation is assured to a maximum ambient temperature T_A of 85°C. Therefore, the maximum power dissipation is about TBD mW. More power can be dissipated if the maximum ambient temperature of the application is lower.

REVISION HISTORY

Changes from Revision B (December 2009) to Revision C	Page
• Deleted Fixed Output Voltage Options from 1.8V to 5.0V	1
• Deleted adjustable output feature from DESCRIPTION.	1
• Deleted adjustable output feature listed in the ORDERING INFORMATION table.	2
• Deleted V_{OUT} parameters for the TPS61097-18, TPS61097-27, TPS61097-30, and TPS61097-50 from the ELECTRICAL CHARACTERISTICS table.	3
• Deleted Overvoltage protection threshold parameter.	3
• Deleted the adjustable output voltage pinout package.	4
• Deleted the adjustable output voltage features from the Terminal Functions table.	4
• Deleted the Functional Block Diagram for the adjustable output version.	5
• Deleted "Overvoltage Protection" and "Programming the Output Voltage" sections.	16

PACKAGING INFORMATION

Orderable Device	Status (1)	Package Type	Package Drawing	Pins	Package Qty	Eco Plan (2)	Lead/Ball Finish (6)	MSL Peak Temp (3)	Op Temp (°C)	Device Marking (4/5)	Samples
TPS61097-33DBVR	ACTIVE	SOT-23	DBV	5	3000	Green (RoHS & no Sb/Br)	CU NIPDAU	Level-1-260C-UNLIM	-40 to 85	(NFSF ~ NFSK)	Samples
TPS61097-33DBVT	ACTIVE	SOT-23	DBV	5	250	Green (RoHS & no Sb/Br)	CU NIPDAU	Level-1-260C-UNLIM	-40 to 85	NFSK	Samples

(1) The marketing status values are defined as follows:

ACTIVE: Product device recommended for new designs.

LIFEBUY: TI has announced that the device will be discontinued, and a lifetime-buy period is in effect.

NRND: Not recommended for new designs. Device is in production to support existing customers, but TI does not recommend using this part in a new design.

PREVIEW: Device has been announced but is not in production. Samples may or may not be available.

OBSOLETE: TI has discontinued the production of the device.

(2) Eco Plan - The planned eco-friendly classification: Pb-Free (RoHS), Pb-Free (RoHS Exempt), or Green (RoHS & no Sb/Br) - please check <http://www.ti.com/productcontent> for the latest availability information and additional product content details.

TBD: The Pb-Free/Green conversion plan has not been defined.

Pb-Free (RoHS): TI's terms "Lead-Free" or "Pb-Free" mean semiconductor products that are compatible with the current RoHS requirements for all 6 substances, including the requirement that lead not exceed 0.1% by weight in homogeneous materials. Where designed to be soldered at high temperatures, TI Pb-Free products are suitable for use in specified lead-free processes.

Pb-Free (RoHS Exempt): This component has a RoHS exemption for either 1) lead-based flip-chip solder bumps used between the die and package, or 2) lead-based die adhesive used between the die and leadframe. The component is otherwise considered Pb-Free (RoHS compatible) as defined above.

Green (RoHS & no Sb/Br): TI defines "Green" to mean Pb-Free (RoHS compatible), and free of Bromine (Br) and Antimony (Sb) based flame retardants (Br or Sb do not exceed 0.1% by weight in homogeneous material)

(3) MSL, Peak Temp. - The Moisture Sensitivity Level rating according to the JEDEC industry standard classifications, and peak solder temperature.

(4) There may be additional marking, which relates to the logo, the lot trace code information, or the environmental category on the device.

(5) Multiple Device Markings will be inside parentheses. Only one Device Marking contained in parentheses and separated by a "~" will appear on a device. If a line is indented then it is a continuation of the previous line and the two combined represent the entire Device Marking for that device.

(6) Lead/Ball Finish - Orderable Devices may have multiple material finish options. Finish options are separated by a vertical ruled line. Lead/Ball Finish values may wrap to two lines if the finish value exceeds the maximum column width.

Important Information and Disclaimer:The information provided on this page represents TI's knowledge and belief as of the date that it is provided. TI bases its knowledge and belief on information provided by third parties, and makes no representation or warranty as to the accuracy of such information. Efforts are underway to better integrate information from third parties. TI has taken and continues to take reasonable steps to provide representative and accurate information but may not have conducted destructive testing or chemical analysis on incoming materials and chemicals. TI and TI suppliers consider certain information to be proprietary, and thus CAS numbers and other limited information may not be available for release.

In no event shall TI's liability arising out of such information exceed the total purchase price of the TI part(s) at issue in this document sold by TI to Customer on an annual basis.

TAPE AND REEL INFORMATION

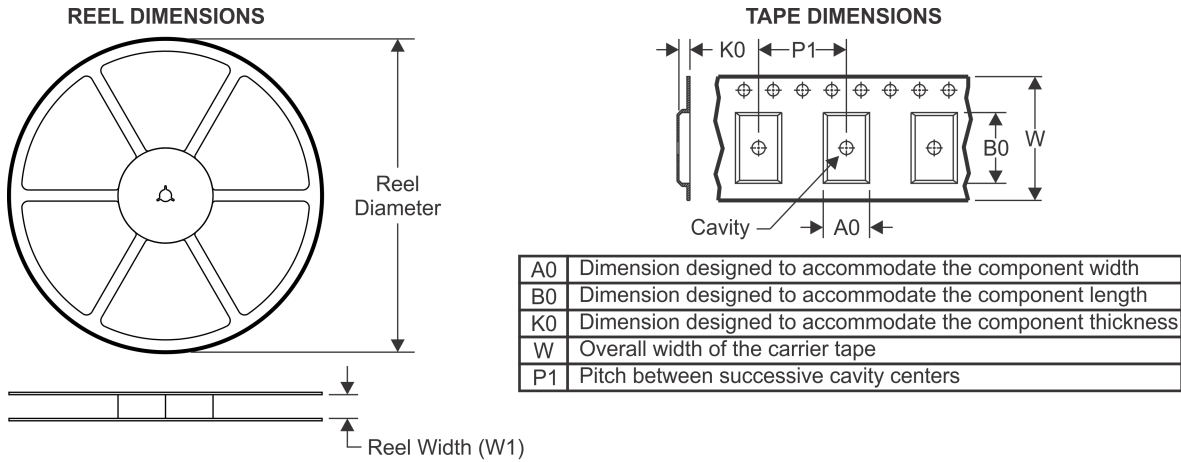

QUADRANT ASSIGNMENTS FOR PIN 1 ORIENTATION IN TAPE

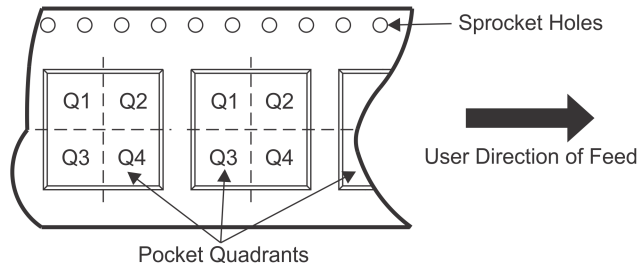

*All dimensions are nominal

Device	Package Type	Package Drawing	Pins	SPQ	Reel Diameter (mm)	Reel Width W1 (mm)	A0 (mm)	B0 (mm)	K0 (mm)	P1 (mm)	W (mm)	Pin1 Quadrant
TPS61097-33DBVR	SOT-23	DBV	5	3000	180.0	8.4	3.23	3.17	1.37	4.0	8.0	Q3

TAPE AND REEL BOX DIMENSIONS

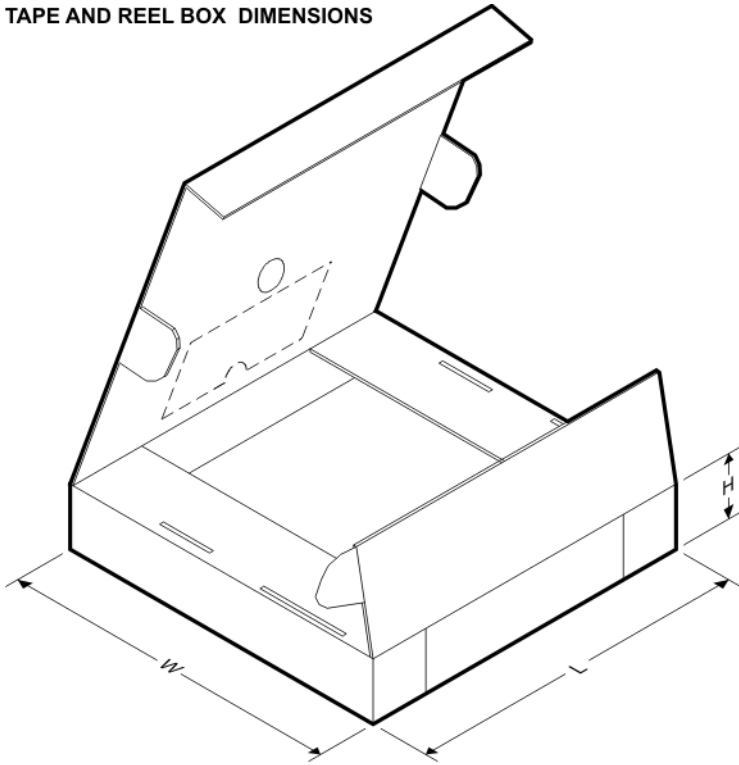

*All dimensions are nominal

Device	Package Type	Package Drawing	Pins	SPQ	Length (mm)	Width (mm)	Height (mm)
TPS61097-33DBVR	SOT-23	DBV	5	3000	202.0	201.0	28.0

DBV (R-PDSO-G5)

PLASTIC SMALL-OUTLINE PACKAGE

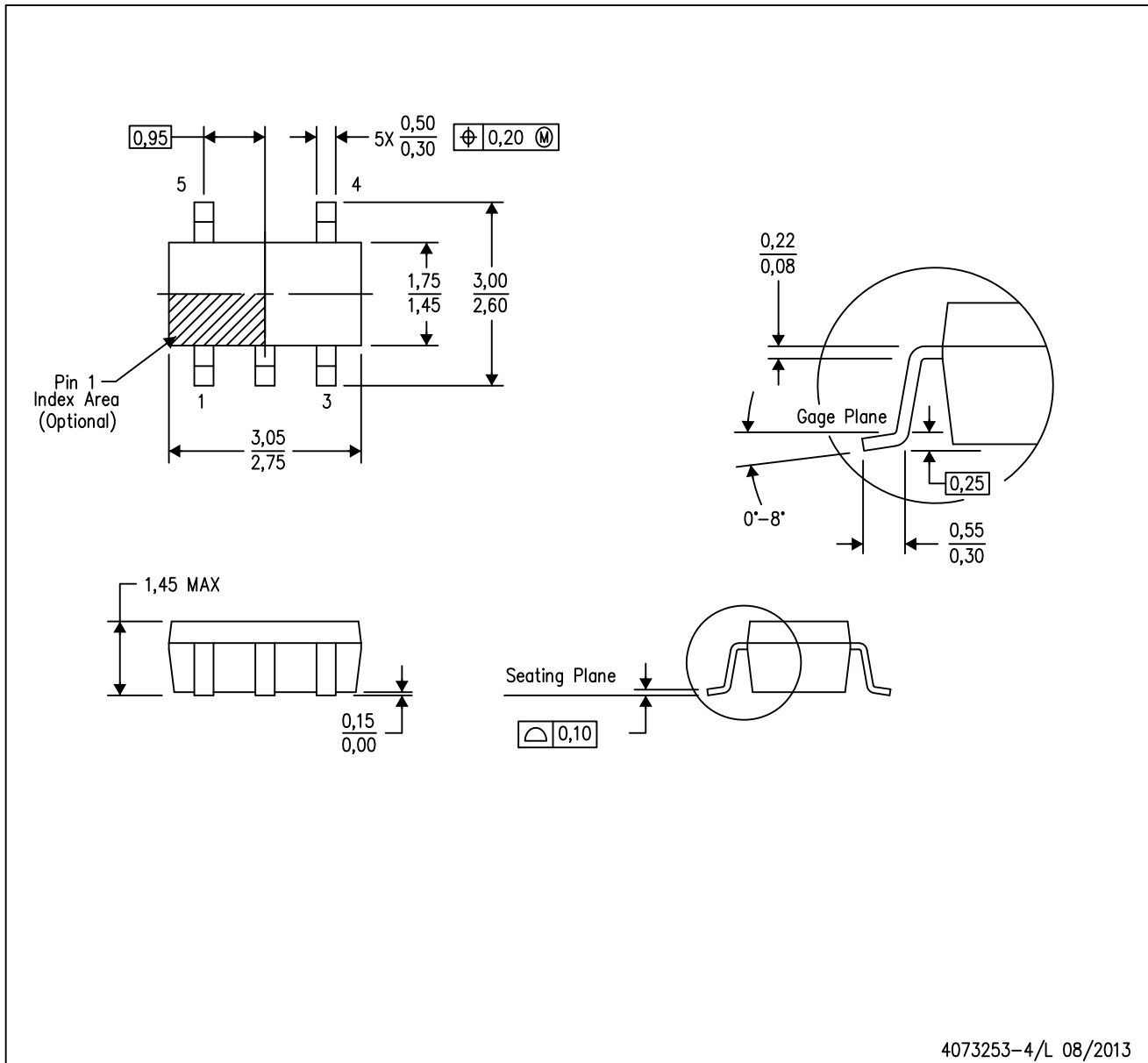

- NOTES:
- All linear dimensions are in millimeters.
 - This drawing is subject to change without notice.
 - Body dimensions do not include mold flash or protrusion. Mold flash and protrusion shall not exceed 0.15 per side.
 - Falls within JEDEC MO-178 Variation AA.

DBV (R-PDSO-G5)

PLASTIC SMALL OUTLINE

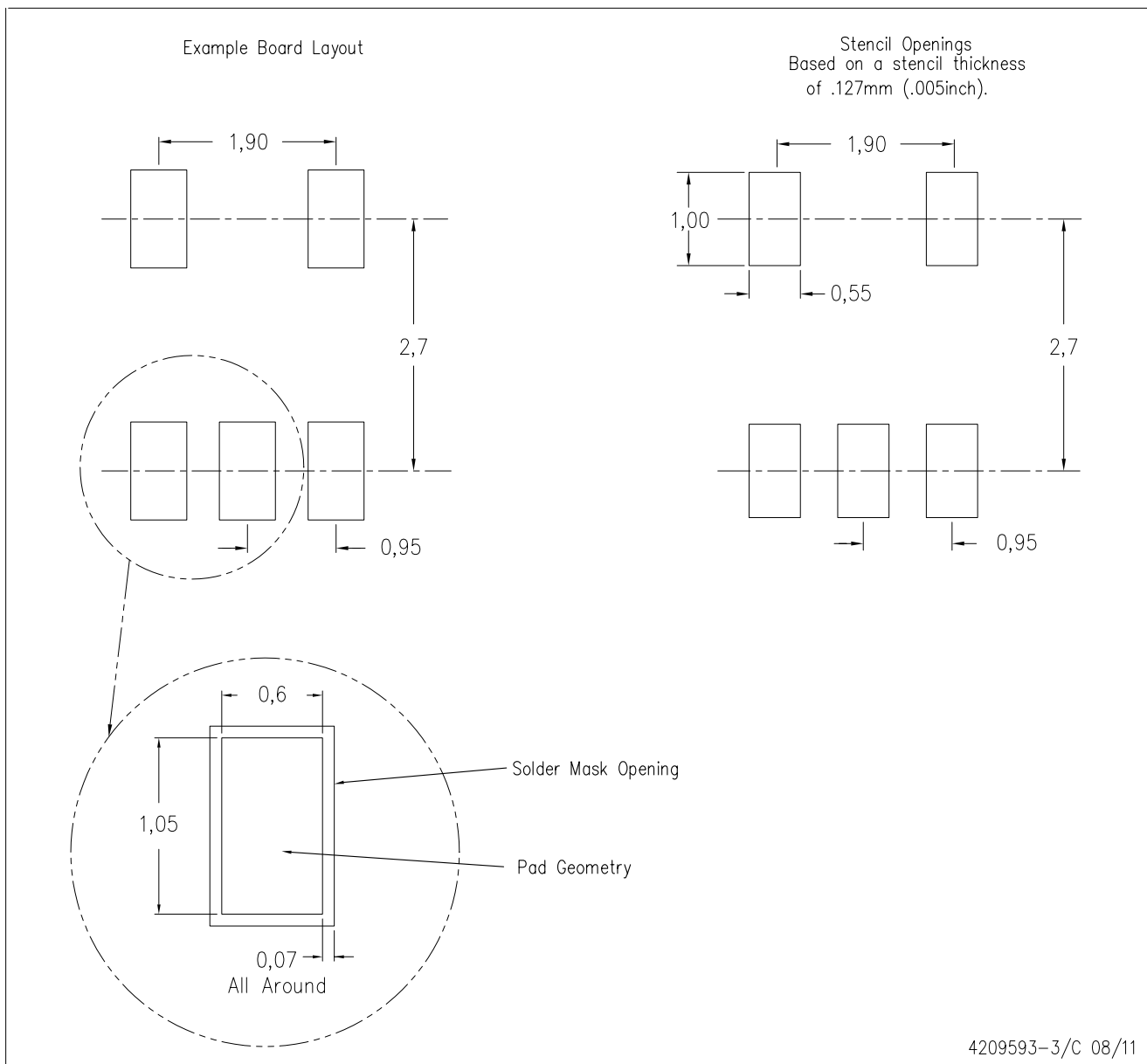

- NOTES:
- A. All linear dimensions are in millimeters.
 - B. This drawing is subject to change without notice.
 - C. Customers should place a note on the circuit board fabrication drawing not to alter the center solder mask defined pad.
 - D. Publication IPC-7351 is recommended for alternate designs.
 - E. Laser cutting apertures with trapezoidal walls and also rounding corners will offer better paste release. Customers should contact their board assembly site for stencil design recommendations. Example stencil design based on a 50% volumetric metal load solder paste. Refer to IPC-7525 for other stencil recommendations.

PACKAGING INFORMATION

Orderable Device	Status (1)	Package Type	Package Drawing	Pins	Package Qty	Eco Plan (2)	Lead finish/ Ball material (6)	MSL Peak Temp (3)	Op Temp (°C)	Device Marking (4/5)	Samples
TPS61097-33DBVR	NRND	SOT-23	DBV	5	3000	RoHS & Green	NIPDAU	Level-1-260C-UNLIM	-40 to 85	(NFSF, NFSK)	
TPS61097-33DBVT	NRND	SOT-23	DBV	5	250	RoHS & Green	NIPDAU	Level-1-260C-UNLIM	-40 to 85	NFSK	

(1) The marketing status values are defined as follows:

ACTIVE: Product device recommended for new designs.

LIFEBUY: TI has announced that the device will be discontinued, and a lifetime-buy period is in effect.

NRND: Not recommended for new designs. Device is in production to support existing customers, but TI does not recommend using this part in a new design.

PREVIEW: Device has been announced but is not in production. Samples may or may not be available.

OBSOLETE: TI has discontinued the production of the device.

(2) **RoHS:** TI defines "RoHS" to mean semiconductor products that are compliant with the current EU RoHS requirements for all 10 RoHS substances, including the requirement that RoHS substance do not exceed 0.1% by weight in homogeneous materials. Where designed to be soldered at high temperatures, "RoHS" products are suitable for use in specified lead-free processes. TI may reference these types of products as "Pb-Free".

RoHS Exempt: TI defines "RoHS Exempt" to mean products that contain lead but are compliant with EU RoHS pursuant to a specific EU RoHS exemption.

Green: TI defines "Green" to mean the content of Chlorine (Cl) and Bromine (Br) based flame retardants meet JS709B low halogen requirements of <=1000ppm threshold. Antimony trioxide based flame retardants must also meet the <=1000ppm threshold requirement.

(3) MSL, Peak Temp. - The Moisture Sensitivity Level rating according to the JEDEC industry standard classifications, and peak solder temperature.

(4) There may be additional marking, which relates to the logo, the lot trace code information, or the environmental category on the device.

(5) Multiple Device Markings will be inside parentheses. Only one Device Marking contained in parentheses and separated by a "~" will appear on a device. If a line is indented then it is a continuation of the previous line and the two combined represent the entire Device Marking for that device.

(6) Lead finish/Ball material - Orderable Devices may have multiple material finish options. Finish options are separated by a vertical ruled line. Lead finish/Ball material values may wrap to two lines if the finish value exceeds the maximum column width.

Important Information and Disclaimer:The information provided on this page represents TI's knowledge and belief as of the date that it is provided. TI bases its knowledge and belief on information provided by third parties, and makes no representation or warranty as to the accuracy of such information. Efforts are underway to better integrate information from third parties. TI has taken and continues to take reasonable steps to provide representative and accurate information but may not have conducted destructive testing or chemical analysis on incoming materials and chemicals. TI and TI suppliers consider certain information to be proprietary, and thus CAS numbers and other limited information may not be available for release.

In no event shall TI's liability arising out of such information exceed the total purchase price of the TI part(s) at issue in this document sold by TI to Customer on an annual basis.

DBV0005A



PACKAGE OUTLINE

SOT-23 - 1.45 mm max height

SMALL OUTLINE TRANSISTOR



4214839/J 02/2024

NOTES:

1. All linear dimensions are in millimeters. Any dimensions in parenthesis are for reference only. Dimensioning and tolerancing per ASME Y14.5M.
2. This drawing is subject to change without notice.
3. Reference JEDEC MO-178.
4. Body dimensions do not include mold flash, protrusions, or gate burrs. Mold flash, protrusions, or gate burrs shall not exceed 0.25 mm per side.
5. Support pin may differ or may not be present.

EXAMPLE BOARD LAYOUT

DBV0005A

SOT-23 - 1.45 mm max height

SMALL OUTLINE TRANSISTOR



LAND PATTERN EXAMPLE
EXPOSED METAL SHOWN
SCALE:15X



SOLDER MASK DETAILS

4214839/J 02/2024

NOTES: (continued)

- 6. Publication IPC-7351 may have alternate designs.
- 7. Solder mask tolerances between and around signal pads can vary based on board fabrication site.

EXAMPLE STENCIL DESIGN

DBV0005A

SOT-23 - 1.45 mm max height

SMALL OUTLINE TRANSISTOR



SOLDER PASTE EXAMPLE
BASED ON 0.125 mm THICK STENCIL
SCALE:15X

4214839/J 02/2024

NOTES: (continued)

8. Laser cutting apertures with trapezoidal walls and rounded corners may offer better paste release. IPC-7525 may have alternate design recommendations.
9. Board assembly site may have different recommendations for stencil design.

IMPORTANT NOTICE AND DISCLAIMER

TI PROVIDES TECHNICAL AND RELIABILITY DATA (INCLUDING DATA SHEETS), DESIGN RESOURCES (INCLUDING REFERENCE DESIGNS), APPLICATION OR OTHER DESIGN ADVICE, WEB TOOLS, SAFETY INFORMATION, AND OTHER RESOURCES "AS IS" AND WITH ALL FAULTS, AND DISCLAIMS ALL WARRANTIES, EXPRESS AND IMPLIED, INCLUDING WITHOUT LIMITATION ANY IMPLIED WARRANTIES OF MERCHANTABILITY, FITNESS FOR A PARTICULAR PURPOSE OR NON-INFRINGEMENT OF THIRD PARTY INTELLECTUAL PROPERTY RIGHTS.

These resources are intended for skilled developers designing with TI products. You are solely responsible for (1) selecting the appropriate TI products for your application, (2) designing, validating and testing your application, and (3) ensuring your application meets applicable standards, and any other safety, security, regulatory or other requirements.

These resources are subject to change without notice. TI grants you permission to use these resources only for development of an application that uses the TI products described in the resource. Other reproduction and display of these resources is prohibited. No license is granted to any other TI intellectual property right or to any third party intellectual property right. TI disclaims responsibility for, and you will fully indemnify TI and its representatives against, any claims, damages, costs, losses, and liabilities arising out of your use of these resources.

TI's products are provided subject to [TI's Terms of Sale](#) or other applicable terms available either on [ti.com](https://www.ti.com) or provided in conjunction with such TI products. TI's provision of these resources does not expand or otherwise alter TI's applicable warranties or warranty disclaimers for TI products.

TI objects to and rejects any additional or different terms you may have proposed.

Mailing Address: Texas Instruments, Post Office Box 655303, Dallas, Texas 75265
Copyright © 2024, Texas Instruments Incorporated