

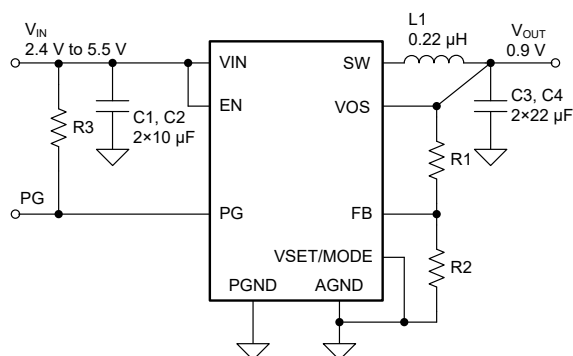
# TPS62865/TPS62867 2.4-V to 5.5-V Input, 4-A and 6-A Synchronous Step-Down Converter in 1.5-mm × 2.5-mm QFN Package

## 1 Features

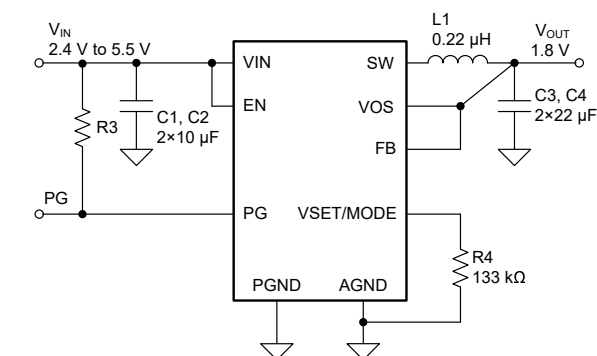
- DCS-Control topology for fast transient response
- 11-mΩ and 10.5-mΩ internal power MOSFETs
- 1% output voltage accuracy
- 4-μA operating quiescent current
- 2.4-V to 5.5-V input voltage range
- 0.6-V to  $V_{IN}$  output voltage range
- Fixed ([selectable by external resistor](#)) and adjustable output voltage versions
- 2.4-MHz switching frequency
- Forced PWM or power save mode
- Output voltage discharge
- 100% duty cycle mode
- Hiccup short-circuit protection
- Power good indicator with window comparator
- Thermal shutdown
- Solution sizes down to 30 mm<sup>2</sup> possible
- Available in 1.5-mm × 2.5-mm QFN with 0.5-mm pitch
- Create a custom design using the TPS62865 with the [WEBENCH® Power Designer](#)
- Create a custom design using the TPS62867 with the [WEBENCH® Power Designer](#)

## 2 Applications

- [Core supply for FPGAs, CPUs, ASICs, or video chipsets](#)
- [Machine vision cameras](#)
- [IP network cameras](#)
- [Solid-state drives](#)
- [Optical modules](#)
- [Multifunction printers](#)



Typical Application Schematics - Adjustable Output Voltage



Typical Application Schematics - Fixed Output Voltage

## 3 Description

The TPS62865 and TPS62867 devices are high-frequency synchronous step-down converters which provide an efficient, flexible, and high power-density solution. At medium to heavy loads, the converters operate in PWM mode and automatically enter Power Save Mode operation at light load to maintain high efficiency over the entire load current range. The devices can also be forced in PWM mode operation to minimize output voltage ripple. Together with its DCS-control architecture, excellent load transient performance and tight output voltage accuracy are achieved. The devices feature a Power Good signal and an internal soft start circuit. The devices are able to operate in 100% mode. For fault protection, the devices incorporate a HICCUP short circuit protection as well as a thermal shutdown.

### Device Information

PART NUMBER	PACKAGE <sup>(1)</sup>	BODY SIZE (NOM)
TPS62865	QFN (9)	1.5 × 2.5 × 1 mm
TPS62867		

- (1) For all available packages, see the orderable addendum at the end of the data sheet.



## Table of Contents

<b>1 Features</b> .....	1	8.4 Device Functional Modes.....	10
<b>2 Applications</b> .....	1	<b>9 Application and Implementation</b> .....	12
<b>3 Description</b> .....	1	9.1 Application Information.....	12
<b>4 Revision History</b> .....	2	9.2 Typical Application.....	12
<b>5 Device Options</b> .....	3	<b>10 Power Supply Recommendations</b> .....	19
<b>6 Pin Configuration and Functions</b> .....	3	<b>11 Layout</b> .....	20
<b>7 Specifications</b> .....	4	11.1 Layout Guidelines.....	20
7.1 Absolute Maximum Ratings .....	4	11.2 Layout Example.....	20
7.2 ESD Ratings .....	4	<b>12 Device and Documentation Support</b> .....	22
7.3 Recommended Operating Conditions .....	4	12.1 Device Support.....	22
7.4 Thermal Information .....	5	12.2 Documentation Support.....	22
7.5 Electrical Characteristics .....	6	12.3 Support Resources.....	22
7.6 Typical Characteristics.....	7	12.4 Trademarks.....	22
<b>8 Detailed Description</b> .....	8	12.5 Electrostatic Discharge Caution.....	22
8.1 Overview.....	8	12.6 Glossary.....	23
8.2 Functional Block Diagram.....	8	<b>13 Mechanical, Packaging, and Orderable Information</b> .....	23
8.3 Feature Description.....	8		

## 4 Revision History

NOTE: Page numbers for previous revisions may differ from page numbers in the current version.

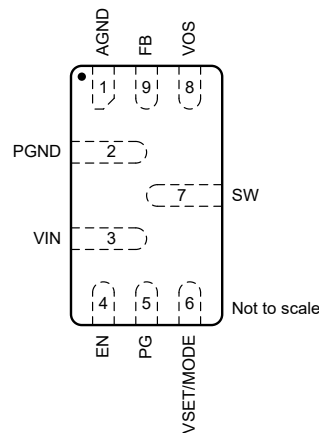
DATE	REVISION	NOTES
March 2021	*	Initial Release

## 5 Device Options

PART NUMBER <sup>(1)</sup>	OUTPUT CURRENT
TPS62865	4 A
TPS62867	6 A

(1) For all available packages, see the orderable addendum at the end of the data sheet.

## 6 Pin Configuration and Functions



**Figure 6-1. 9-Pin RQY QFN Package (Top View)**

**Table 6-1. Pin Functions**

PIN		DESCRIPTION
NAME	NO.	
AGND	1	Analog ground pin
FB	9	Feedback pin. For the fixed output voltage versions, the pin must be connected to the output directly.
VOS	8	Output voltage sense pin. This pin must be directly connected to the output capacitor.
PGND	2	Power ground pin
SW	7	Switch pin of the power stage
VIN	3	Power supply input voltage pin
EN	4	Device enable pin. To enable the device, this pin needs to be pulled high. Pulling this pin low disables the device. Do not leave floating.
VSET/MODE	6	Voltage Set pin In fixed output voltage applications, connect a resistor between this pin and GND to set the output voltage (see <a href="#">Table 8-2</a> ). After start-up, connect this pin to a high level to enable forced-PWM operation, or to a low level to enable power-save mode. In adjustable output voltage applications, connect this pin to a high level to enable forced-PWM operation, or to a low level to enable power-save mode operation.
PG	5	Power-good open-drain output pin. The pullup resistor can be connected to voltages up to 5.5 V. If unused, leave it floating.

## 7 Specifications

### 7.1 Absolute Maximum Ratings

See (1)

		MIN	MAX	UNIT
Voltage <sup>(2)</sup>	VIN, EN, VOS, FB, PG, VSET/MODE	-0.3	6	V
	SW (DC)	-0.3	V <sub>IN</sub> + 0.3	
	SW (AC, less than 10 ns) <sup>(3)</sup>	-2.5	10	
I <sub>SINK_PG</sub>	Sink current at PG		1	mA
T <sub>J</sub>	Junction temperature	-40	150	°C
T <sub>stg</sub>	Storage temperature	-65	150	°C

- (1) Operation outside the *Absolute Maximum Ratings* may cause permanent device damage. *Absolute Maximum Ratings* do not imply functional operation of the device at these or any other conditions beyond those listed under *Recommended Operating Conditions*. If used outside the *Recommended Operating Conditions* but within the *Absolute Maximum Ratings*, the device may not be fully functional, and this may affect device reliability, functionality, performance, and shorten the device lifetime.
- (2) All voltage values are with respect to network ground terminal.
- (3) While switching

### 7.2 ESD Ratings

			VALUE	UNIT
V <sub>(ESD)</sub>	Electrostatic discharge	Human body model (HBM), per ANSI/ESDA/ JEDEC JS-001, all pins <sup>(1)</sup>	±2000	V
		Charged device model (CDM), per JEDEC specification JESD22-C101, all pins <sup>(2)</sup>	±500	

- (1) JEDEC document JEP155 states that 500-V HBM allows safe manufacturing with a standard ESD control process.
- (2) JEDEC document JEP157 states that 250-V CDM allows safe manufacturing with a standard ESD control process.

### 7.3 Recommended Operating Conditions

Over operating junction temperature range (unless otherwise noted)

		MIN	NOM	MAX	UNIT
V <sub>IN</sub>	Supply Voltage Range	2.4		5.5	V
V <sub>OUT</sub>	Output Voltage Range	0.6		V <sub>IN</sub>	V
SR	Slew rate at VIN <sup>(1)</sup>	-10			mV/μs
I <sub>OUT</sub>	Output current, TPS62865			4	A
	Output current, TPS62867			6	
T <sub>J</sub>	Junction temperature	-40		125	°C

- (1) The falling slew rate of V<sub>IN</sub> must be limited if V<sub>IN</sub> goes below V<sub>UVLO</sub>.

## 7.4 Thermal Information

THERMAL METRIC <sup>(1)</sup>		TPS6286x		UNIT
		JEDEC 51-7	TPS62867EVM-121	
		9 PINS	9 PINS	
$R_{\theta JA}$	Junction-to-ambient thermal resistance	90.9	60.3	°C/W
$R_{\theta JC(top)}$	Junction-to-case (top) thermal resistance	68.2	n/a <sup>(2)</sup>	°C/W
$R_{\theta JB}$	Junction-to-board thermal resistance	25.0	n/a <sup>(2)</sup>	°C/W
$\Psi_{JT}$	Junction-to-top characterization parameter	1.9	3.3	°C/W
$\Psi_{JB}$	Junction-to-board characterization parameter	24.7	31.5	°C/W

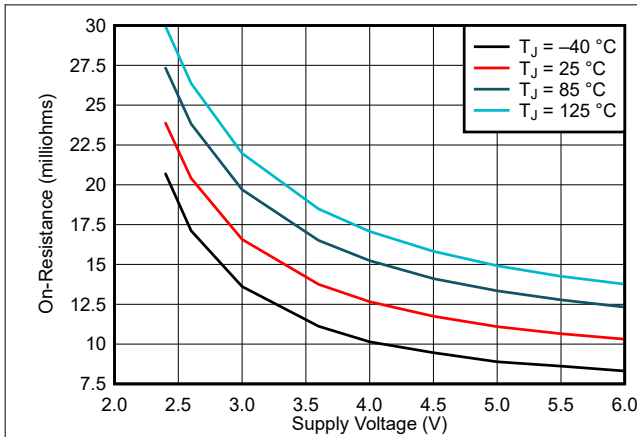
- (1) For more information about traditional and new thermal metrics, see the [Semiconductor and IC Package Thermal Metrics](#) application report.
- (2) Not applicable to an EVM

## 7.5 Electrical Characteristics

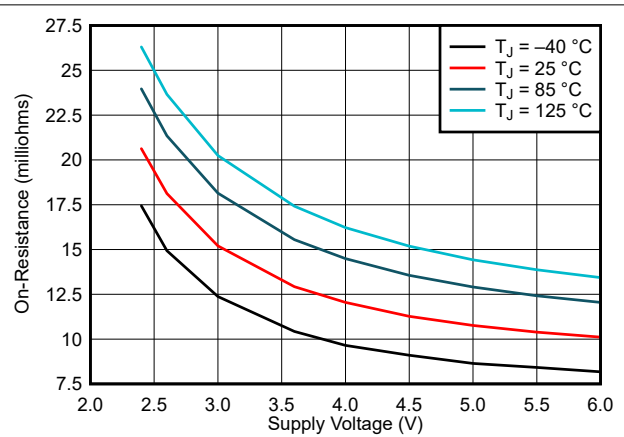
$T_J = -40^{\circ}\text{C}$  to  $125^{\circ}\text{C}$ , and  $V_{IN} = 2.4\text{ V}$  to  $5.5\text{ V}$ . Typical values are at  $T_J = 25^{\circ}\text{C}$  and  $V_{IN} = 5\text{ V}$ , unless otherwise noted.

PARAMETER		TEST CONDITIONS	MIN	TYP	MAX	UNIT
<b>SUPPLY</b>						
$I_Q$	Quiescent current	EN = High, no load, device not switching		4	10	$\mu\text{A}$
$I_{Q,VOS}$	Operating quiescent current into VOS pin	EN = High, no load, device not switching, $V_{VOS} = 1.8\text{ V}$		8		$\mu\text{A}$
$I_{SD}$	Shutdown current	EN = Low, $T_J = -40^{\circ}\text{C}$ to $85^{\circ}\text{C}$		0.24	1	$\mu\text{A}$
$V_{UVLO}$	Undervoltage lockout threshold	$V_{IN}$ rising	2.2	2.3	2.4	V
		$V_{IN}$ falling	2.1	2.2	2.3	V
$T_{JSD}$	Thermal shutdown threshold	$T_J$ rising		150		$^{\circ}\text{C}$
	Thermal shutdown hysteresis	$T_J$ falling		20		$^{\circ}\text{C}$
<b>LOGIC INTERFACE</b>						
$V_{IH}$	High-level input threshold voltage at EN and VSET/MODE		0.84			V
$V_{IL}$	Low-level input threshold voltage at EN and VSET/MODE				0.4	V
$I_{EN,LKG}$	Input leakage current into EN pin			0.01	0.1	$\mu\text{A}$
<b>STARTUP, POWER GOOD</b>						
$t_{Delay}$	Enable delay time	Time from EN high to device starts switching 249-k $\Omega$ resistor connected between VSET/MODE and GND	420	700	1100	$\mu\text{s}$
$t_{Ramp}$	Output voltage ramp time	Time from device starts switching to power good	0.8	1	1.5	ms
$V_{PG}$	Power good lower threshold	$V_{VOS}$ referenced to $V_{OUT}$ nominal	85%	91%	96%	
	Power good upper threshold	$V_{VOS}$ referenced to $V_{OUT}$ nominal	103%	111%	120%	
$V_{PG,OL}$	Low-level output voltage	$I_{sink} = 1\text{ mA}$ , PG pin version			0.36	V
$t_{PG,DLY}$	Power good deglitch delay	Rising and falling edges		34		$\mu\text{s}$
<b>OUTPUT</b>						
$V_{OUT}$	Output voltage accuracy	Fixed voltage operation, FPWM, no load, $T_J = 0^{\circ}\text{C}$ to $85^{\circ}\text{C}$	-1%		1%	
		Fixed voltage operation, FPWM, no load	-2%		2%	
$V_{FB}$	Feedback voltage	Adjustable voltage operation	594	600	606	mV
$I_{FB,LKG}$	Input leakage into FB pin	Adjustable voltage operation, $V_{FB} = 0.6\text{ V}$		0.01	0.4	$\mu\text{A}$
$I_{VOS,LKG}$	Input leakage current into VOS pin	Output discharge disabled, $V_{VOS} = 1.8\text{ V}$		0.2	2.5	$\mu\text{A}$
$R_{DIS}$	Output discharge resistor at VOS pin			3.5		$\Omega$
	Load regulation	$V_{OUT} = 0.9\text{ V}$ , FPWM		0.04		%/A
<b>POWER SWITCH</b>						
$R_{DS(on)}$	High-side FET on-resistance			11		m $\Omega$
	Low-side FET on-resistance			10.5		m $\Omega$
$I_{LIM}$	High-side FET forward current limit	TPS62865	5	5.5	6	A
		TPS62867	7	7.7	8.5	A
	Low-side FET forward current limit	TPS62865		4.5		A
		TPS62867		6.5		A
Low-side FET negative current limit	TPS62865, TPS62867		-3		A	
$f_{SW}$	PWM switching frequency	$I_{OUT} = 1\text{ A}$ , $V_{OUT} = 0.9\text{ V}$		2.4		MHz

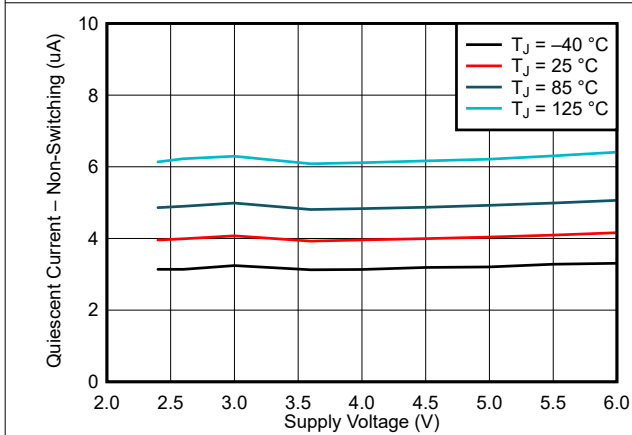
## 7.6 Typical Characteristics



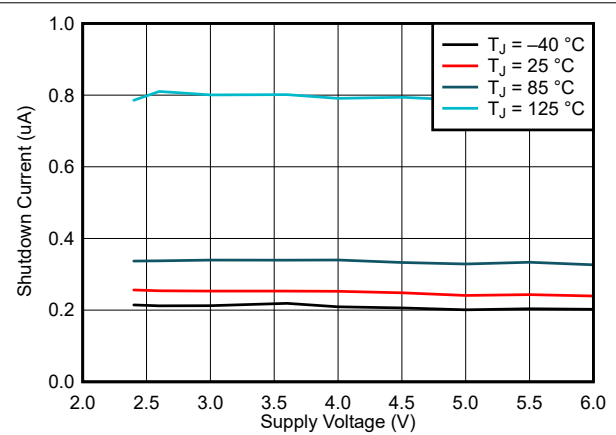
**Figure 7-1. High-Side FET On-Resistance**



**Figure 7-2. Low-Side FET On-Resistance**



**Figure 7-3. Quiescent Current**



**Figure 7-4. Shutdown Current**

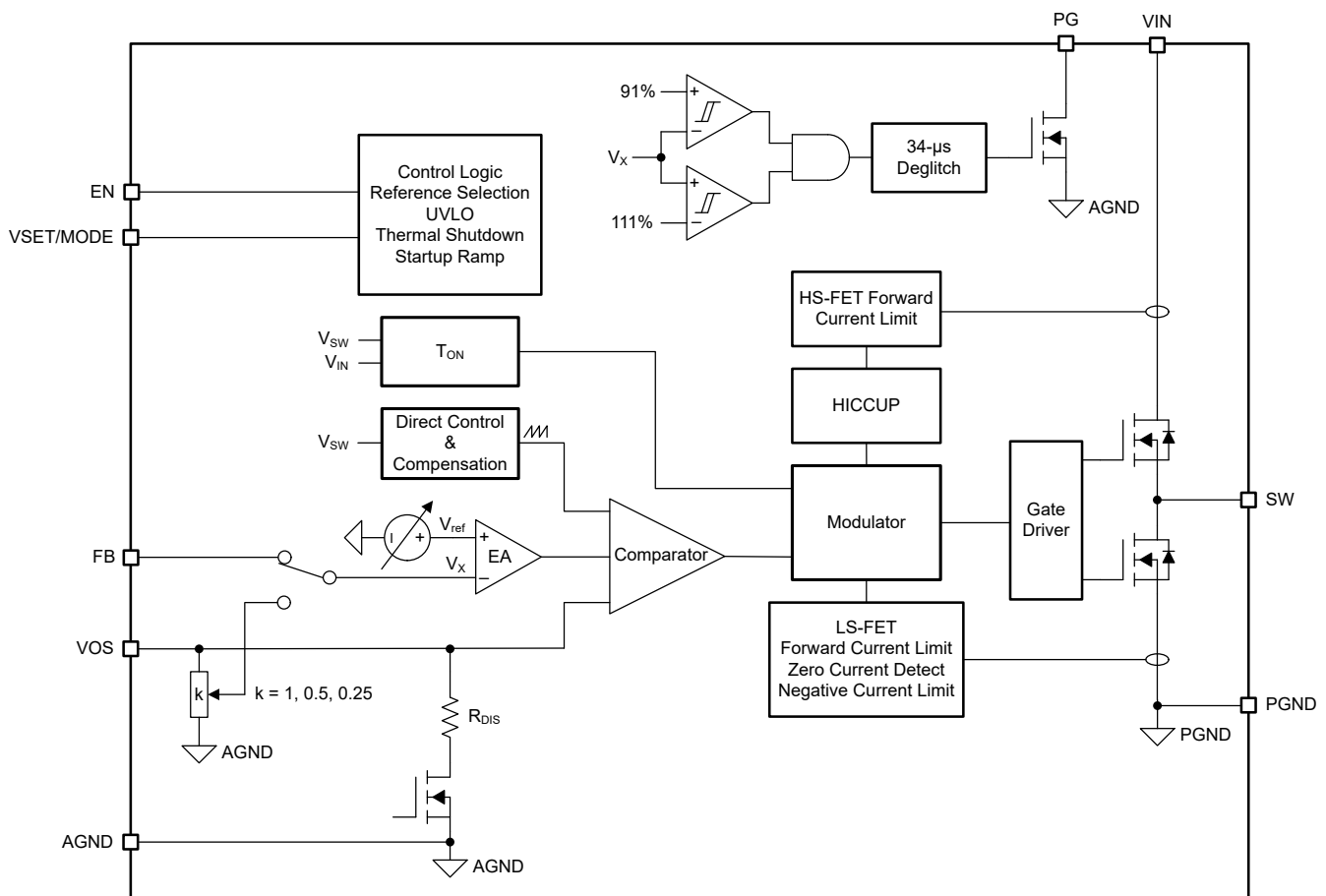
## 8 Detailed Description

### 8.1 Overview

The TPS62865 and TPS62867 synchronous step-down converters use the DCS-Control (Direct Control with Seamless transition into Power Save Mode) topology. This is an advanced regulation topology that combines the advantages of hysteretic and current-mode control schemes.

The DCS-Control topology operates in PWM (pulse width modulation) mode for medium to heavy load conditions and in Power Save Mode at light load currents. In PWM mode, the converter operates with its 2.4-MHz nominal switching frequency, having a controlled frequency variation over the input voltage range. Since DCS-Control supports both operation modes (PWM and PFM) within a single building block, the transition from PWM mode to Power Save Mode is seamless and does not affect on the output voltage. The devices offer both excellent DC voltage and superior load transient regulation combined with very low output voltage ripple.

### 8.2 Functional Block Diagram



### 8.3 Feature Description

#### 8.3.1 Power Save Mode

As the load current decreases, the device enters Power Save Mode (PSM) operation. PSM occurs when the inductor current becomes discontinuous, which is when it reaches 0 A during a switching cycle. Power Save Mode is based on a fixed on-time architecture, as shown in [Equation 1](#).

$$t_{ON} = \frac{V_{OUT}}{V_{IN}} \times 416 \text{ ns} \quad (1)$$



In Power Save Mode, the output voltage rises slightly above the nominal output voltage. This effect is minimized by increasing the output capacitor or inductor value.

When  $V_{IN}$  decreases to typically 15% above  $V_{OUT}$ , the TP6286x does enter Power Save Mode, regardless of the load current. The device maintains output regulation in PWM mode.

### 8.3.2 Forced PWM Mode

Connecting the VSET/MODE pin to logic high after the start-up, the device switches at 2.4 MHz, even with a light load. This reduces the output voltage ripple and allows simple filtering of the switching frequency for noise-sensitive applications. Efficiency at light load is lower in Forced PWM mode (FPWM).

### 8.3.3 100% Duty Cycle Mode Operation

There is no limitation for small duty cycles since even at very low duty cycles, the switching frequency is reduced as needed to always ensure a proper regulation.

If the output voltage level comes close to the input voltage, the device enters 100% mode. While the high-side switch is constantly turned on, the low-side switch is switched off. The difference between  $V_{IN}$  and  $V_{OUT}$  is determined by the voltage drop across the high-side MOSFET and the DC resistance of the inductor. The minimum  $V_{IN}$  that is needed to maintain a specific  $V_{OUT}$  value is estimated as:

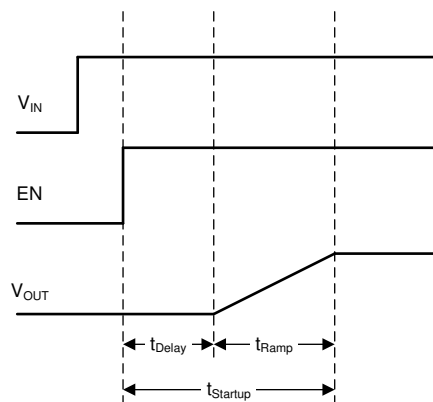
$$V_{IN,MIN} = V_{OUT} + (R_{DS(ON)} + R_L)I_{OUT,MAX} \quad (2)$$

where

- $V_{IN,MIN}$  is the minimum input voltage to maintain an output voltage
- $I_{OUT,MAX}$  is the maximum output current
- $R_{DS(on)}$  is the high-side FET ON-resistance
- $R_L$  is the inductor ohmic resistance (DCR)

### 8.3.4 Soft Start

After enabling the device, there is a 700- $\mu$ s (typical) enable delay ( $t_{delay}$ ) before the device starts switching. After the enable delay, an internal soft start-up circuitry ramps up the output voltage with a period of 1 ms ( $t_{Ramp}$ ). This avoids excessive inrush current and creates a smooth output voltage rise-slope. It also prevents excessive voltage drops of primary cells and rechargeable batteries with high internal impedance. The device is able to start into a pre-biased output capacitor. It starts with the applied bias voltage and ramps the output voltage to its nominal value.



**Figure 8-1. Start-up Sequence**

### 8.3.5 Switch Current Limit and HICCUP Short-Circuit Protection

The switch current limit prevents the device from high inductor current and from drawing excessive current from the battery or input voltage rail. Excessive current might occur with a shorted or saturated inductor or a heavy load or shorted output circuit condition. If the inductor current reaches the threshold  $I_{LIM}$ , cycle by cycle, the

high-side MOSFET is turned off and the low-side MOSFET is turned on, while the inductor current ramps down to the low-side MOSFET current limit.

When the high-side MOSFET current limit is triggered 32 times, the device stops switching. The device then automatically re-starts with an internal soft start-up after a typical delay time of 128  $\mu$ s has passed. This is named HICCUP short-circuit protection. The device repeats this mode until the high load condition disappears.

### 8.3.6 Undervoltage Lockout

To avoid mis-operation of the device at low input voltages, undervoltage lockout (UVLO) is implemented when the input voltage is lower than  $V_{UVLO}$ . The device stops switching and the output voltage discharge is active when the device is in UVLO. When the input voltage recovers, the device automatically returns to operation with an internal soft start-up.

### 8.3.7 Thermal Shutdown

When the junction temperature exceeds  $T_{JSD}$ , the device goes into thermal shutdown, stops switching, and activates the output voltage discharge. When the device temperature falls below the threshold by the hysteresis, the device returns to normal operation automatically with an internal soft start-up. During thermal shutdown, the internal register values are kept.

## 8.4 Device Functional Modes

### 8.4.1 Enable and Disable (EN)

The device is enabled by setting the EN pin to a logic high. In shutdown mode (EN = low), the internal power switches and the entire control circuitry are turned off. An internal switch smoothly discharges the output through the VOS pin in shutdown mode. Do not leave the EN pin floating.

### 8.4.2 Power Good (PG)

The device has an open-drain power-good pin, which is specified to sink up to 1 mA. The power-good output requires a pullup resistor connecting to any voltage rail less than 5.5 V. The PG has a deglitch delay of 34  $\mu$ s.

The PG signal can be used for sequencing of multiple rails by connecting it to the EN pin of other converters. Leave the PG pin unconnected when not used.

**Table 8-1. PG Function Table**

DEVICE CONDITIONS		PG PIN
Enable	$0.9 \times V_{OUT\_NOM} \leq V_{VOS} \leq 1.1 \times V_{OUT\_NOM}$	Hi-Z
	$V_{VOS} < 0.9 \times V_{OUT\_NOM}$ or $V_{VOS} > 1.1 \times V_{OUT\_NOM}$	Low
Shutdown	EN = low	Low
Thermal shutdown	$T_J > T_{JSD}$	Low
UVLO	$1.8 \text{ V} < V_{IN} < V_{UVLO}$	Low
Power supply removal	$V_{IN} < 1.8 \text{ V}$	Undefined

### 8.4.3 Voltage Setting and Mode Selection (VSET/MODE)

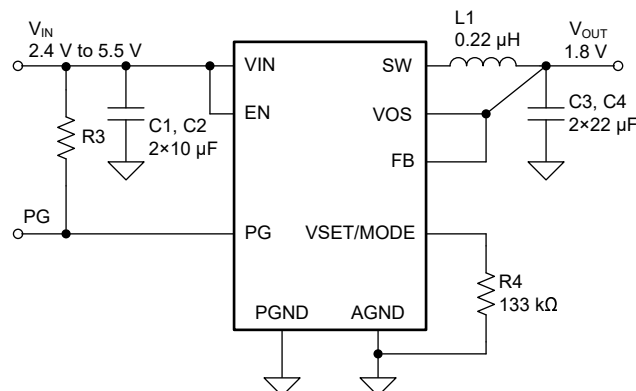
During the enable delay ( $t_{Delay}$ ), the device configuration is set by an external resistor connected to the VSET/MODE pin through an internal R2D (resistor to digital) converter. [Table 8-2](#) shows the options.

The R2D converter has an internal current source that applies current through the external resistor and an internal ADC that reads back the resulting voltage level. Depending on the level, the output voltage is set. Once this R2D conversion is finished, the current source is turned off to avoid current flowing through the external resistor. Ensure that there is no additional current path or capacitance greater than 30 pF from this pin to GND during R2D conversion. Otherwise, a false value is set.

**Table 8-2. Voltage Selection Table**

RESISTOR (E96 SERIES, ±1% ACCURACY) AT VSET/MODE PIN	FIXED OR ADJUSTABLE OUTPUT VOLTAGE
249 kΩ or logic high	adjustable
205 kΩ	3.30 V
162 kΩ	2.50 V
133 kΩ	1.80 V
105 kΩ	1.50 V
86.6 kΩ	reserved
68.1 kΩ	1.35 V
56.2 kΩ	1.20 V
44.2 kΩ	1.10 V
36.5 kΩ	1.05 V
28.7 kΩ	1.00 V
23.7 kΩ	0.95 V
18.7 kΩ	0.90 V
15.4 kΩ	0.85 V
12.1 kΩ	0.80 V
10 kΩ or logic low	adjustable

When the device is set as a fixed output voltage converter, then FB pin must be connected to the output directly. Refer to [Figure 8-2](#).



**Figure 8-2. Fixed Start-up Output Voltage Application Circuit**

After the start-up period ( $t_{Startup}$ ), a different operation mode can be selected. When VSET/MODE is high, the device operates in forced PWM mode, otherwise the device operates in power save mode.

## 9 Application and Implementation

### Note

Information in the following applications sections is not part of the TI component specification, and TI does not warrant its accuracy or completeness. TI's customers are responsible for determining suitability of components for their purposes, as well as validating and testing their design implementation to confirm system functionality.

### 9.1 Application Information

The following section discusses the design of the external components to complete the power supply design for several input and output voltage options by using typical applications as a reference.

### 9.2 Typical Application

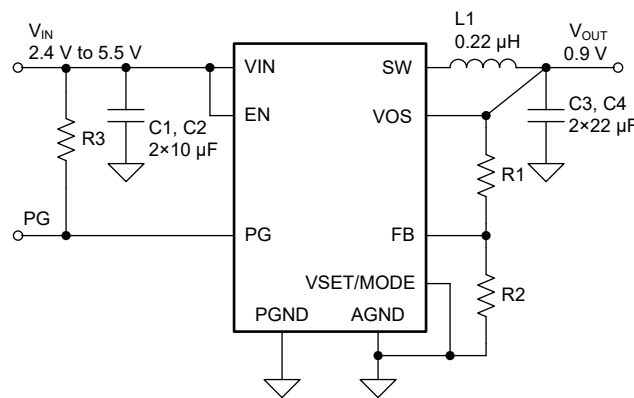


Figure 9-1. Typical Application

#### 9.2.1 Design Requirements

For this design example, use the parameters listed in Table 9-1 as the input parameters.

Table 9-1. Design Parameters

DESIGN PARAMETER	EXAMPLE VALUE
Input voltage	2.4 V to 5.5 V
Output voltage	0.9 V
Maximum output current	6 A

Table 9-2 lists the components used for the example.

Table 9-2. List of Components

REFERENCE	DESCRIPTION	MANUFACTURER <sup>(1)</sup>
C1, C2	10 $\mu$ F, ceramic capacitor, 10 V, X7R, size 0603, GRM188Z71A106KA73	Murata
C3, C4	22 $\mu$ F, ceramic capacitor, 6.3 V, X7R, size 0805, GRM21BZ70J226ME44	Murata
L1	0.22 $\mu$ H, power inductor, XAL4020-221ME (12 A, 5.81 m $\Omega$ )	Coilcraft
R1	Depending on the output voltage, chip resistor, 1/16 W, 1%, size 0402	Std
R2	100 k $\Omega$ , chip resistor, 1/16 W, 1%, size 0402	Std
R3	100 k $\Omega$ , chip resistor, 1/16 W, 1%, size 0402	Std

(1) See the [Third-party Products](#) disclaimer.

## 9.2.2 Detailed Design Procedure

### 9.2.2.1 Custom Design With WEBENCH® Tools

[Click here](#) to create a custom design using the TPS62865 device with the WEBENCH® Power Designer.

[Click here](#) to create a custom design using the TPS62867 device with the WEBENCH® Power Designer.

1. Start by entering the input voltage ( $V_{IN}$ ), output voltage ( $V_{OUT}$ ), and output current ( $I_{OUT}$ ) requirements.
2. Optimize the design for key parameters such as efficiency, footprint, and cost using the optimizer dial.
3. Compare the generated design with other possible solutions from Texas Instruments.

The WEBENCH Power Designer provides a customized schematic along with a list of materials with real-time pricing and component availability.

In most cases, these actions are available:

- Run electrical simulations to see important waveforms and circuit performance
- Run thermal simulations to understand board thermal performance
- Export customized schematic and layout into popular CAD formats
- Print PDF reports for the design, and share the design with colleagues

Get more information about WEBENCH tools at [www.ti.com/WEBENCH](http://www.ti.com/WEBENCH).

### 9.2.2.2 Setting The Output Voltage

The output voltage is set by an external resistor divider according to [Equation 3](#):

$$R1 = R2 \left( \frac{V_{OUT}}{V_{FB}} - 1 \right) = R2 \left( \frac{V_{OUT}}{0.6V} - 1 \right) \quad (3)$$

R2 must not be higher than 200 kΩ to achieve high efficiency at light load while providing acceptable noise sensitivity.

For the fixed output versions, connect the FB pin to the output. R1 and R2 are not needed.

### 9.2.2.3 Output Filter Design

The inductor and the output capacitor together provide a low-pass filter. To simplify this process, [Table 9-3](#) outlines possible inductor and capacitor value combinations for most applications. Checked cells represent combinations that are proven for stability by simulation and lab testing. Further combinations must be checked for each individual application.

**Table 9-3. Matrix of Output Capacitor and Inductor Combinations**

NOMINAL L [ $\mu$ H] <sup>(2)</sup>	NOMINAL C <sub>OUT</sub> [ $\mu$ F] <sup>(3)</sup>			
	10	2 × 22 or 47	3 × 22	150
0.22		+(1)	+	+

(1) This LC combination is the standard value and recommended for most applications.

(2) Inductor tolerance and current derating is anticipated. The effective inductance can vary by 20% and –30%.

(3) Capacitance tolerance and bias voltage derating is anticipated. The effective capacitance can vary by 20% and –50%.

### 9.2.2.4 Inductor Selection

The main parameter for the inductor selection is the inductor value, then the saturation current of the inductor. To calculate the maximum inductor current under static load conditions, [Equation 4](#) is given.

$$I_{L,MAX} = I_{OUT,MAX} + \frac{\Delta I_L}{2}$$

$$\Delta I_L = V_{OUT} \left( \frac{1 - \frac{V_{OUT}}{V_{IN}}}{L \times f_{SW}} \right) \tag{4}$$

where

- $I_{OUT,MAX}$  is the maximum output current
- $\Delta I_L$  is the inductor current ripple
- $f_{SW}$  is the switching frequency
- $L$  is the inductor value

It is recommended to choose a saturation current for the inductor that is approximately 20% to 30% higher than  $I_{L,MAX}$ . In addition, DC resistance and size must also be taken into account when selecting an appropriate inductor. [Table 9-4](#) lists recommended inductors.

**Table 9-4. List of Recommended Inductors**

INDUCTANCE [μH] <sup>(1)</sup>	CURRENT RATING [A]	DIMENSIONS [L × W × H mm]	DC RESISTANCE [mΩ]	PART NUMBER
0.22	18.7	4 × 4 × 2	5.81	Coilcraft, XAL4020-221ME
0.24	6.6	2 × 1.6 × 1.2	13	Murata, DFE201612E-R24M

(1) See the [Third-party Products](#) disclaimer.

### 9.2.2.5 Capacitor Selection

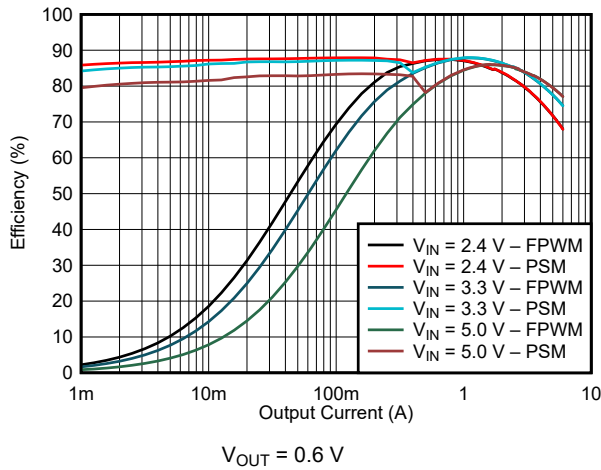
The input capacitor is the low-impedance energy source for the converters which helps to provide stable operation. A low-ESR multilayer ceramic capacitor is recommended for the best filtering and must be placed between VIN and GND as close as possible to those pins. For most applications, 8 μF of *effective*<sup>1</sup> capacitance is sufficient, however, a larger value reduces input current ripple.

The architecture of the device allows the use of tiny ceramic output capacitors with low equivalent series resistance (ESR). These capacitors provide low output voltage ripple and are recommended. To keep its low resistance up to high frequencies and to get narrow capacitance variation with temperature, TI recommends using X7R or X5R dielectrics. The recommended typical output capacitor value is 30 μF of *effective*<sup>1</sup> capacitance. This capacitance can vary over a wide range as outlined in the output filter selection table.

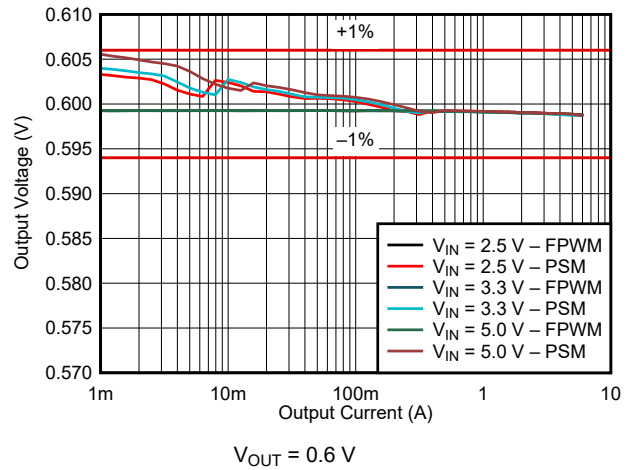
<sup>1</sup> The effective capacitance is the capacitance after tolerance, temperature, and DC bias effects have been considered.

### 9.2.3 Application Curves

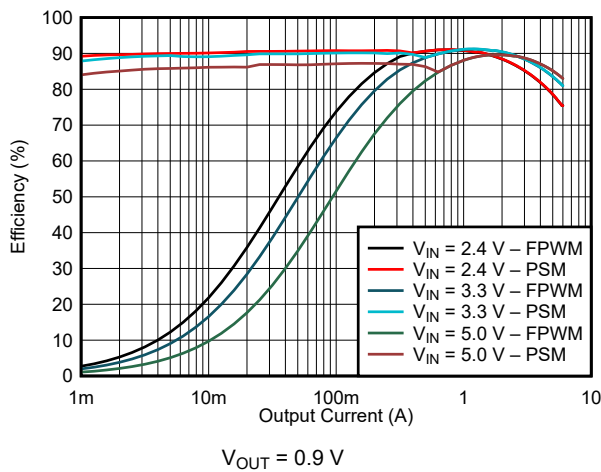
$V_{IN} = 5.0\text{ V}$ ,  $V_{OUT} = 0.9\text{ V}$ ,  $T_A = 25\text{ }^\circ\text{C}$ , BOM = [Table 9-2](#), unless otherwise noted.



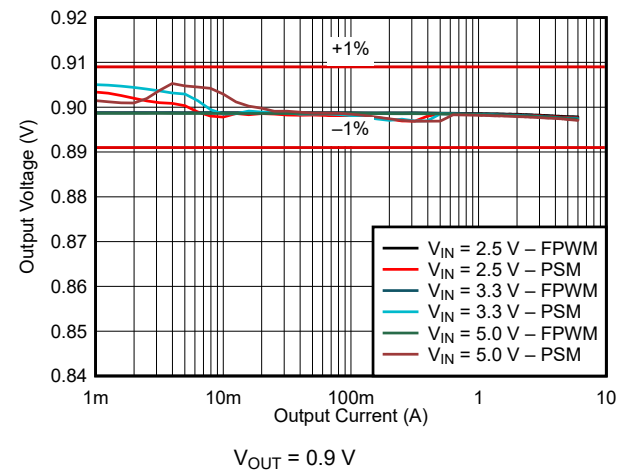
**Figure 9-2. Efficiency**



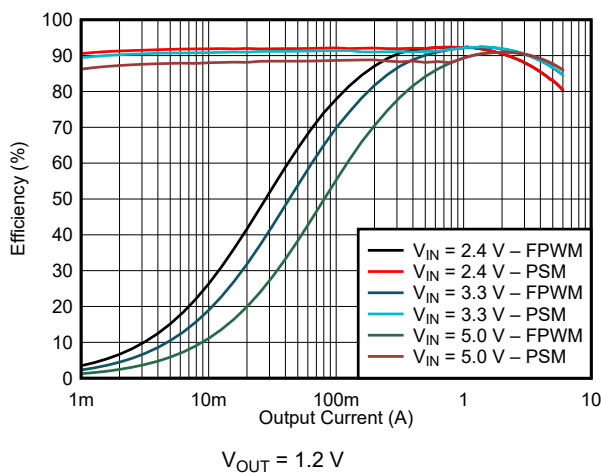
**Figure 9-3. Load Regulation**



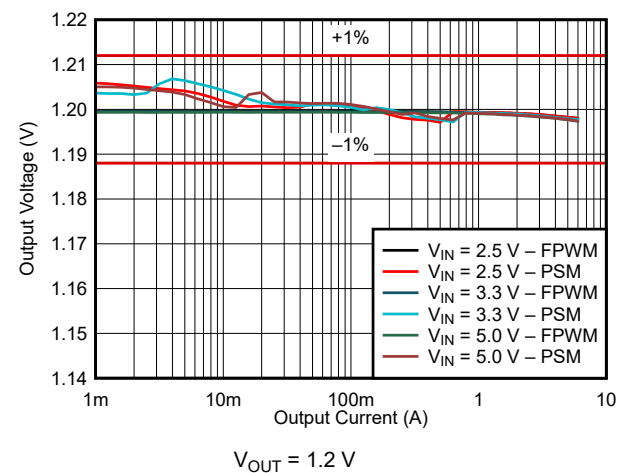
**Figure 9-4. Efficiency**



**Figure 9-5. Load Regulation**

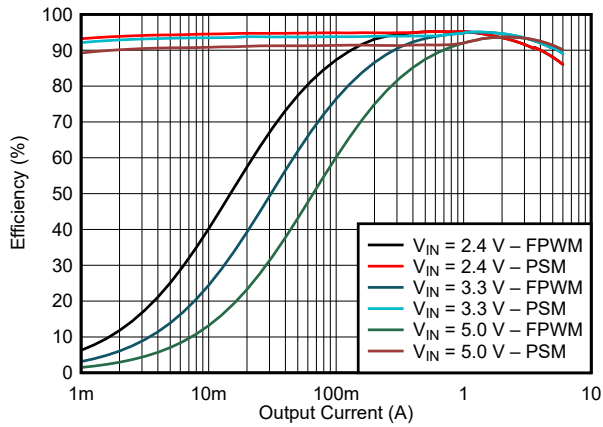


**Figure 9-6. Efficiency**



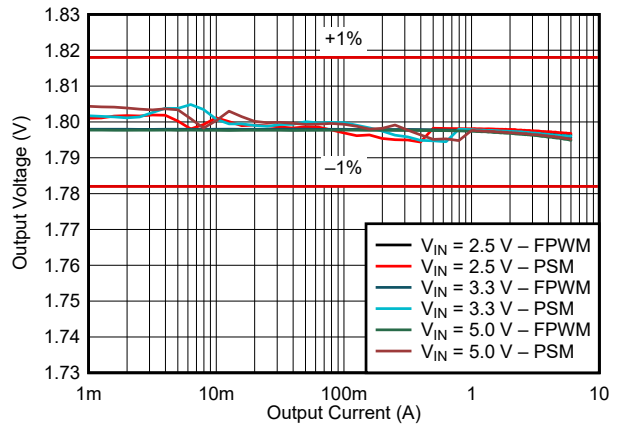
**Figure 9-7. Load Regulation**

### 9.2.3 Application Curves (continued)



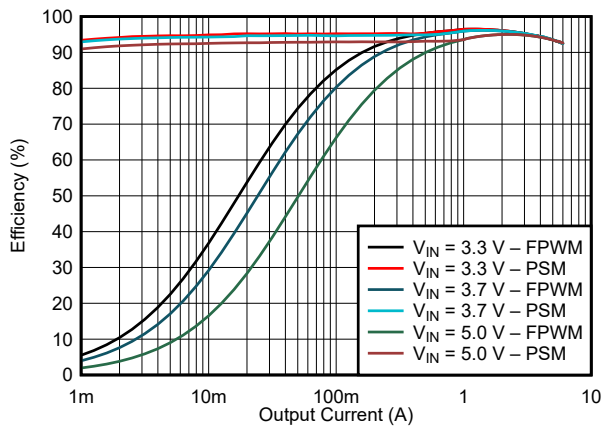
$V_{OUT} = 1.8\text{ V}$

**Figure 9-8. Efficiency**



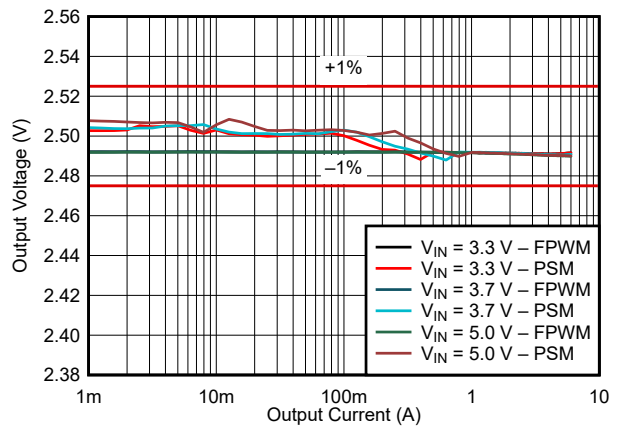
$V_{OUT} = 1.8\text{ V}$

**Figure 9-9. Load Regulation**



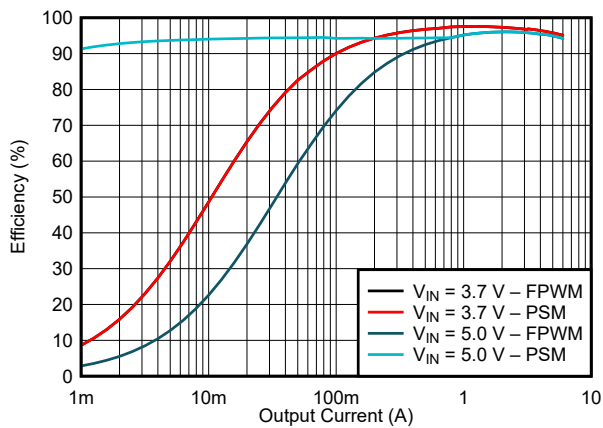
$V_{OUT} = 2.5\text{ V}$

**Figure 9-10. Efficiency**



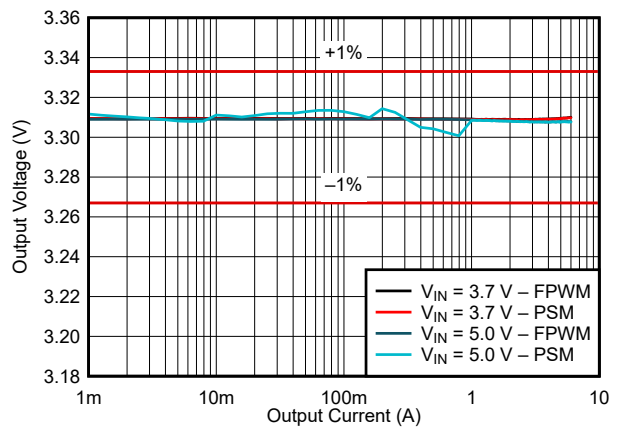
$V_{OUT} = 2.5\text{ V}$

**Figure 9-11. Load Regulation**



$V_{OUT} = 3.3\text{ V}$

**Figure 9-12. Efficiency**



$V_{OUT} = 3.3\text{ V}$

**Figure 9-13. Load Regulation**



### 9.2.3 Application Curves (continued)

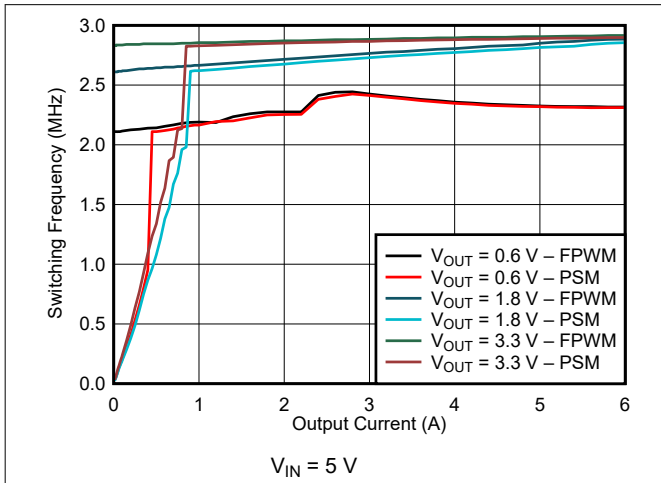


Figure 9-14. Switching Frequency

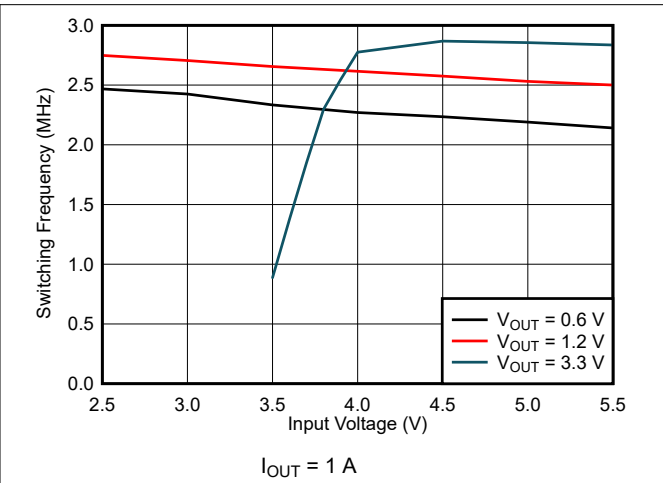


Figure 9-15. Switching Frequency

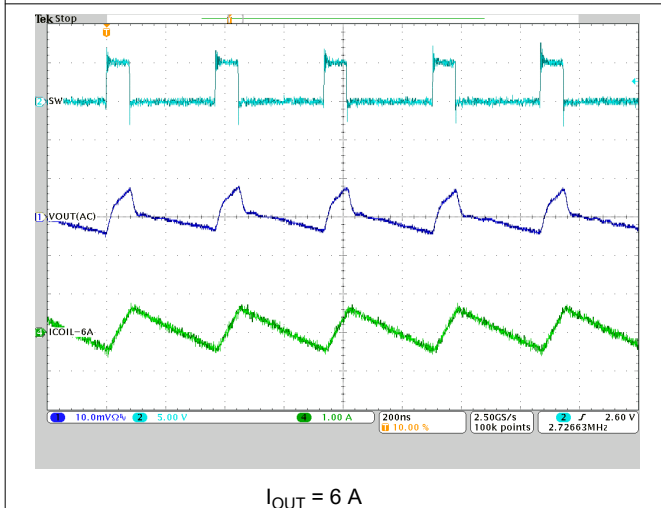


Figure 9-16. PWM Operation

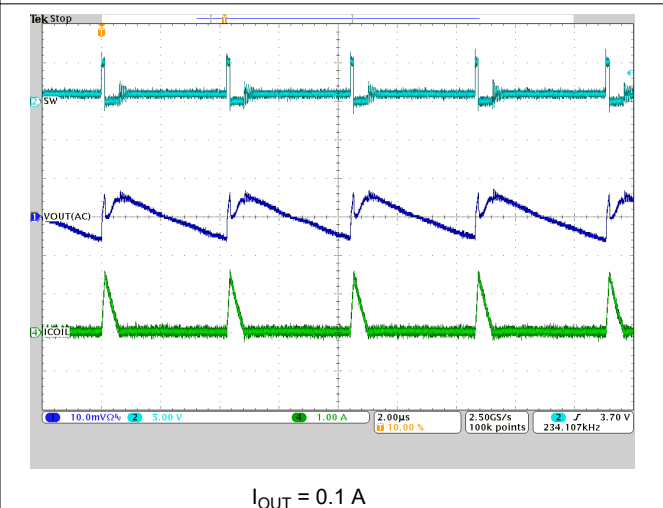


Figure 9-17. PSM Operation

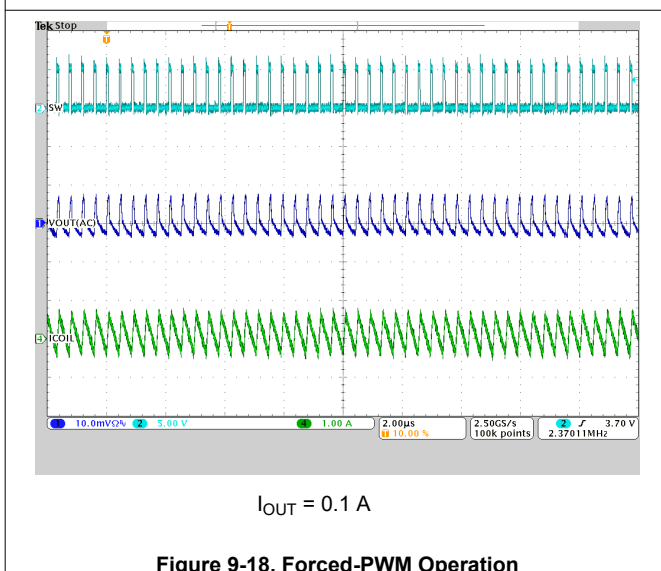


Figure 9-18. Forced-PWM Operation

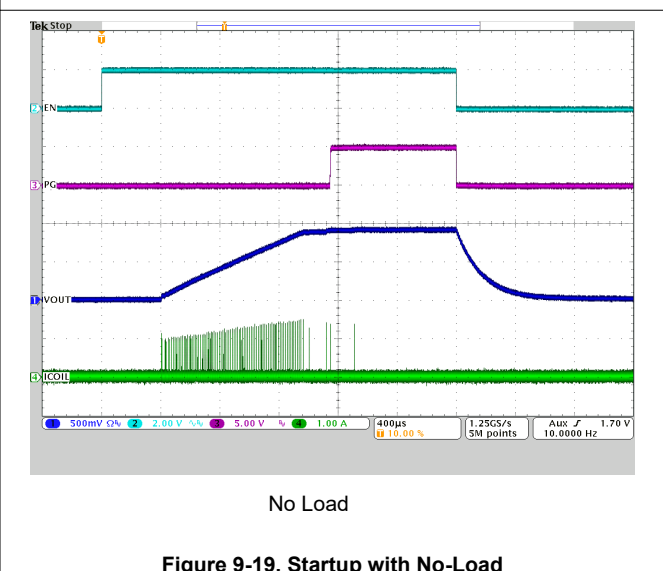
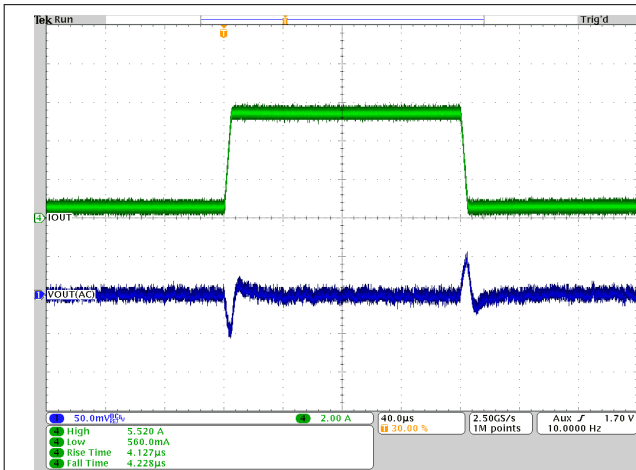


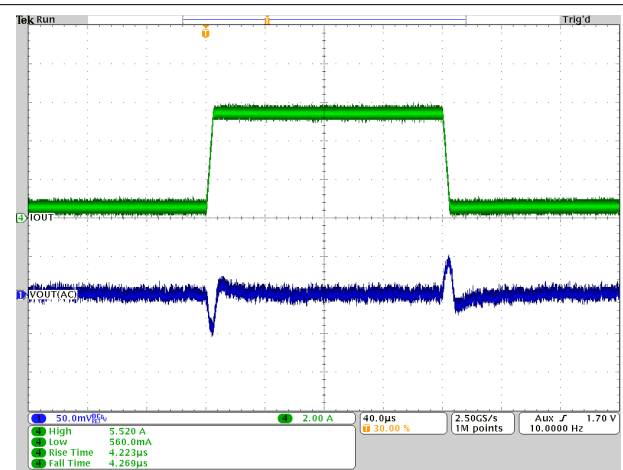
Figure 9-19. Startup with No-Load

### 9.2.3 Application Curves (continued)



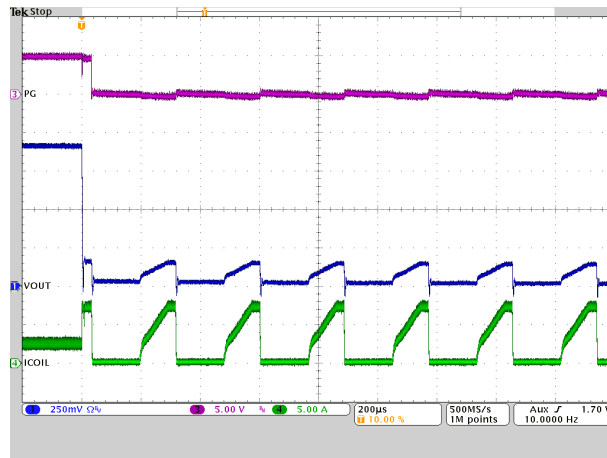
$I_{OUT} = 0.6 \text{ A to } 5.4 \text{ A}$

Figure 9-20. Load Transient - PWM Operation



$I_{OUT} = 0.6 \text{ A to } 5.4 \text{ A}$

Figure 9-21. Load Transient - PSM Operation



$I_{OUT} = 1 \text{ A}$

Figure 9-22. HICCUP Short Circuit Protection

## 10 Power Supply Recommendations

The device is designed to operate from an input voltage supply range from 2.4 V to 5.5 V. Ensure that the input power supply has a sufficient current rating for the application.

## 11 Layout

### 11.1 Layout Guidelines

A proper layout is critical for the operation of any switched mode power supply, especially at high switching frequencies. The PCB layout of the TPS62865 and TPS62867 devices requires careful attention to ensure best performance. A poor layout can lead to issues like bad line and load regulation, instability, increased EMI radiation, and noise sensitivity. Refer to the [Five Steps to a Great PCB Layout for a Step-Down Converter](#) technical brief for a detailed discussion of general best practices. The following are specific recommendations for the TPS62865 and TPS62867:

- The input capacitor or capacitors must be placed as close as possible to the VIN and PGND pins of the device. This is the most critical component placement. Route the input capacitor or capacitors directly to the VIN and PGND pins, avoiding vias.
- Place the output inductor close to the SW pins. Minimize the copper area at the switch node.
- Place the output capacitor or capacitors ground close to the PGND pin and route it directly, avoiding vias. Minimize the length of the connection from the inductor to the output capacitor. Connect the VOS pin directly to the output capacitor.
- Sensitive traces, such as the connections to the VOS, FB, and VSEL pins, must be connected with short traces and be routed away from any noise source, such as the SW pin.
- Make the connections from the input voltage of the system and the connection to the load as wide as possible to minimize voltage drops.
- Have a solid ground plane between PGND and the input and output capacitor ground connections.
- The sensitive signal ground connections for the feedback voltage divider must be connected to a separate signal ground trace.

### 11.2 Layout Example

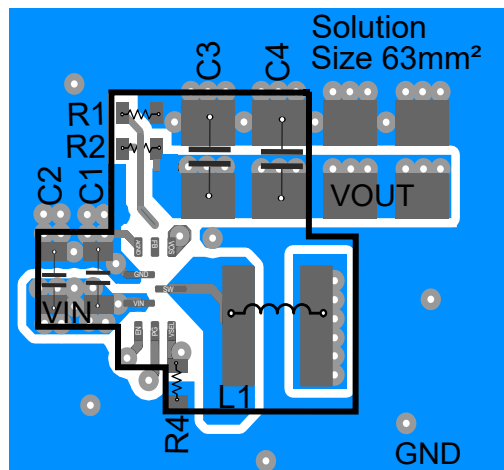


Figure 11-1. Layout Example

#### 11.2.1 Thermal Considerations

After the layout recommendations for component placement and routing have been followed, the PCB design must focus on thermal performance. Thermal design is important and must be considered to remove the heat generated in the device during operation. The device junction temperature must stay below its maximum rated temperature of 125°C for correct operation.

Use wide traces and planes, especially to the PGND, VIN, and VOUT pins, and use vias to internal planes to improve the power dissipation capability of the design. If the application allows it, use airflow in the system to further improve cooling.

The *Thermal Information* table provides the thermal parameters of the device and its package based on the JEDEC standard 51-7. See the *Semiconductor and IC Package Thermal Metrics* application report for a detailed explanation of each parameter. In addition to the JEDEC standard, the thermal information table also contains the thermal parameters of the EVM. The EVM better reflects a real-world PCB design with thicker traces connecting to the device.

## 12 Device and Documentation Support

### 12.1 Device Support

#### 12.1.1 Third-Party Products Disclaimer

TI'S PUBLICATION OF INFORMATION REGARDING THIRD-PARTY PRODUCTS OR SERVICES DOES NOT CONSTITUTE AN ENDORSEMENT REGARDING THE SUITABILITY OF SUCH PRODUCTS OR SERVICES OR A WARRANTY, REPRESENTATION OR ENDORSEMENT OF SUCH PRODUCTS OR SERVICES, EITHER ALONE OR IN COMBINATION WITH ANY TI PRODUCT OR SERVICE.

#### 12.1.2 Development Support

##### 12.1.2.1 Custom Design With WEBENCH® Tools

[Click here](#) to create a custom design using the TPS62865 device with the WEBENCH® Power Designer.

[Click here](#) to create a custom design using the TPS62867 device with the WEBENCH® Power Designer.

1. Start by entering the input voltage ( $V_{IN}$ ), output voltage ( $V_{OUT}$ ), and output current ( $I_{OUT}$ ) requirements.
2. Optimize the design for key parameters such as efficiency, footprint, and cost using the optimizer dial.
3. Compare the generated design with other possible solutions from Texas Instruments.

The WEBENCH Power Designer provides a customized schematic along with a list of materials with real-time pricing and component availability.

In most cases, these actions are available:

- Run electrical simulations to see important waveforms and circuit performance
- Run thermal simulations to understand board thermal performance
- Export customized schematic and layout into popular CAD formats
- Print PDF reports for the design, and share the design with colleagues

Get more information about WEBENCH tools at [www.ti.com/WEBENCH](http://www.ti.com/WEBENCH).

### 12.2 Documentation Support

#### 12.2.1 Related Documentation

For related documentation, see the following:

- Texas Instruments, [Thermal Characteristics of Linear and Logic Packages Using JEDEC PCB Designs](#) application report
- Texas Instruments, [Semiconductor and IC Package Thermal Metrics](#) application report

### 12.3 Support Resources

TI E2E™ [support forums](#) are an engineer's go-to source for fast, verified answers and design help — straight from the experts. Search existing answers or ask your own question to get the quick design help you need.

Linked content is provided "AS IS" by the respective contributors. They do not constitute TI specifications and do not necessarily reflect TI's views; see TI's [Terms of Use](#).

### 12.4 Trademarks

TI E2E™ is a trademark of Texas Instruments.

WEBENCH® are registered trademarks of Texas Instruments.

All trademarks are the property of their respective owners.

### 12.5 Electrostatic Discharge Caution



This integrated circuit can be damaged by ESD. Texas Instruments recommends that all integrated circuits be handled with appropriate precautions. Failure to observe proper handling and installation procedures can cause damage.

ESD damage can range from subtle performance degradation to complete device failure. Precision integrated circuits may be more susceptible to damage because very small parametric changes could cause the device not to meet its published specifications.

## 12.6 Glossary

[TI Glossary](#) This glossary lists and explains terms, acronyms, and definitions.

## 13 Mechanical, Packaging, and Orderable Information

The following pages include mechanical, packaging, and orderable information. This information is the most current data available for the designated devices. This data is subject to change without notice and revision of this document. For browser-based versions of this data sheet, refer to the left-hand navigation.

**PACKAGING INFORMATION**

Orderable part number	Status (1)	Material type (2)	Package   Pins	Package qty   Carrier	RoHS (3)	Lead finish/ Ball material (4)	MSL rating/ Peak reflow (5)	Op temp (°C)	Part marking (6)
<a href="#">TPS62865RQYR</a>	Active	Production	VQFN-HR (RQY)   9	3000   LARGE T&R	Yes	SN	Level-2-260C-1 YEAR	-40 to 125	2EAH
<a href="#">TPS62867RQYR</a>	Active	Production	VQFN-HR (RQY)   9	3000   LARGE T&R	Yes	SN	Level-2-260C-1 YEAR	-40 to 125	2DWH

(1) **Status:** For more details on status, see our [product life cycle](#).

(2) **Material type:** When designated, preproduction parts are prototypes/experimental devices, and are not yet approved or released for full production. Testing and final process, including without limitation quality assurance, reliability performance testing, and/or process qualification, may not yet be complete, and this item is subject to further changes or possible discontinuation. If available for ordering, purchases will be subject to an additional waiver at checkout, and are intended for early internal evaluation purposes only. These items are sold without warranties of any kind.

(3) **RoHS values:** Yes, No, RoHS Exempt. See the [TI RoHS Statement](#) for additional information and value definition.

(4) **Lead finish/Ball material:** Parts may have multiple material finish options. Finish options are separated by a vertical ruled line. Lead finish/Ball material values may wrap to two lines if the finish value exceeds the maximum column width.

(5) **MSL rating/Peak reflow:** The moisture sensitivity level ratings and peak solder (reflow) temperatures. In the event that a part has multiple moisture sensitivity ratings, only the lowest level per JEDEC standards is shown. Refer to the shipping label for the actual reflow temperature that will be used to mount the part to the printed circuit board.

(6) **Part marking:** There may be an additional marking, which relates to the logo, the lot trace code information, or the environmental category of the part.

Multiple part markings will be inside parentheses. Only one part marking contained in parentheses and separated by a "~" will appear on a part. If a line is indented then it is a continuation of the previous line and the two combined represent the entire part marking for that device.

**Important Information and Disclaimer:** The information provided on this page represents TI's knowledge and belief as of the date that it is provided. TI bases its knowledge and belief on information provided by third parties, and makes no representation or warranty as to the accuracy of such information. Efforts are underway to better integrate information from third parties. TI has taken and continues to take reasonable steps to provide representative and accurate information but may not have conducted destructive testing or chemical analysis on incoming materials and chemicals. TI and TI suppliers consider certain information to be proprietary, and thus CAS numbers and other limited information may not be available for release.

In no event shall TI's liability arising out of such information exceed the total purchase price of the TI part(s) at issue in this document sold by TI to Customer on an annual basis.



## TAPE AND REEL INFORMATION



### QUADRANT ASSIGNMENTS FOR PIN 1 ORIENTATION IN TAPE



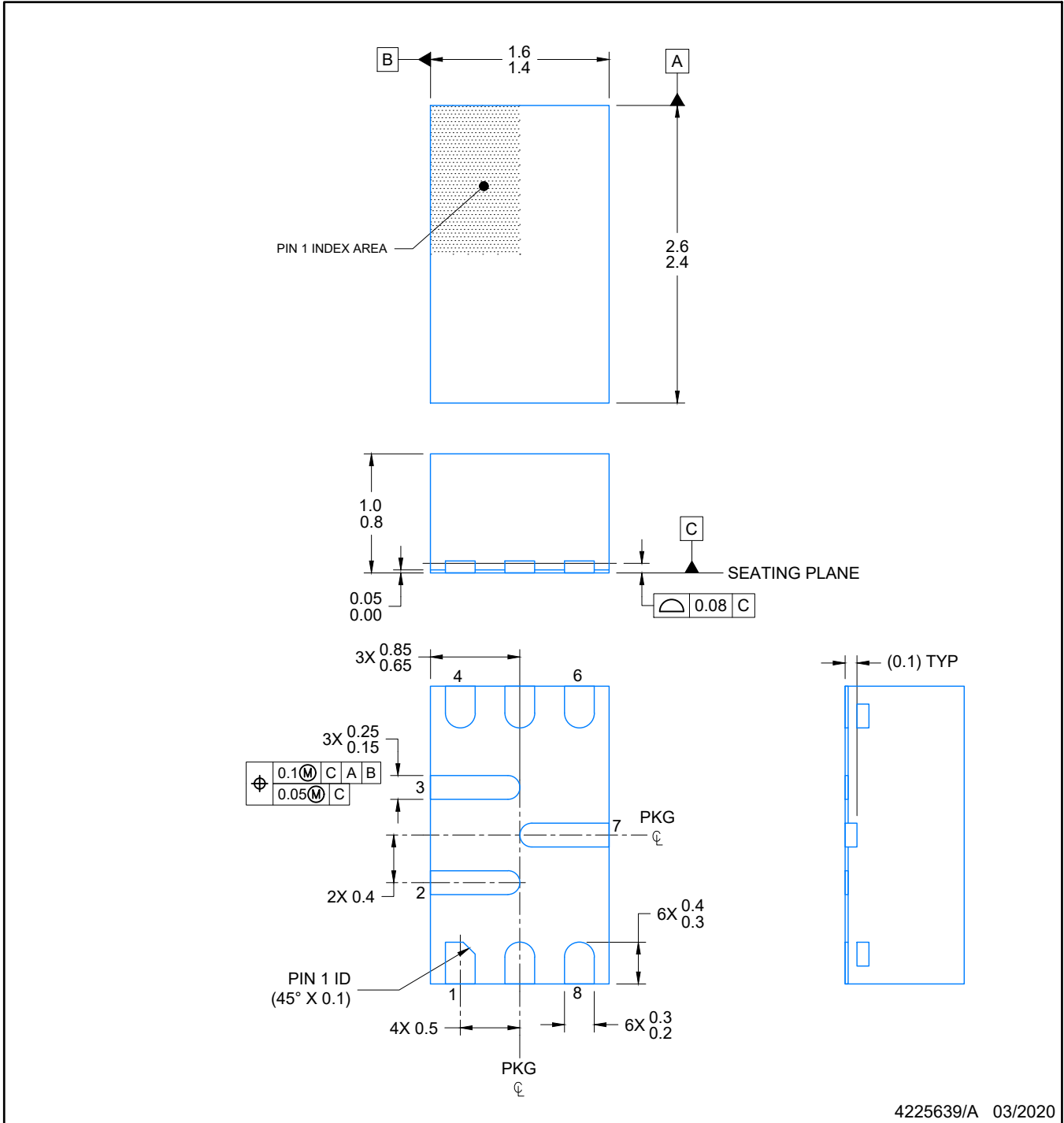
\*All dimensions are nominal

Device	Package Type	Package Drawing	Pins	SPQ	Reel Diameter (mm)	Reel Width W1 (mm)	A0 (mm)	B0 (mm)	K0 (mm)	P1 (mm)	W (mm)	Pin1 Quadrant
TPS62865RQYR	VQFN-HR	RQY	9	3000	180.0	8.4	1.8	2.8	1.12	4.0	8.0	Q1
TPS62867RQYR	VQFN-HR	RQY	9	3000	180.0	8.4	1.8	2.8	1.12	4.0	8.0	Q1

**TAPE AND REEL BOX DIMENSIONS**


\*All dimensions are nominal

Device	Package Type	Package Drawing	Pins	SPQ	Length (mm)	Width (mm)	Height (mm)
TPS62865RQYR	VQFN-HR	RQY	9	3000	210.0	185.0	35.0
TPS62867RQYR	VQFN-HR	RQY	9	3000	210.0	185.0	35.0



4225639/A 03/2020

NOTES:

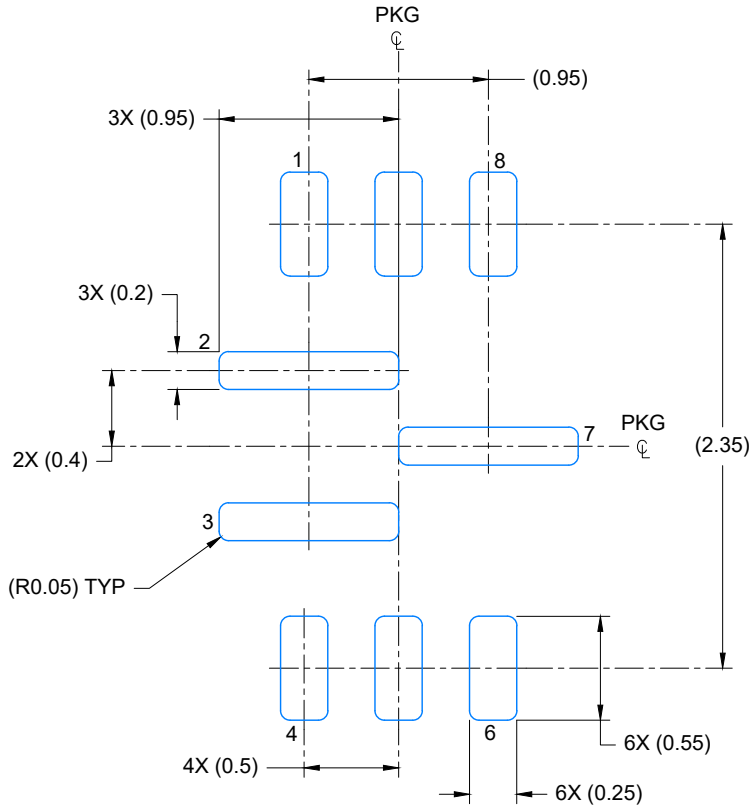
1. All linear dimensions are in millimeters. Any dimensions in parenthesis are for reference only. Dimensioning and tolerancing per ASME Y14.5M.
2. This drawing is subject to change without notice.

# EXAMPLE BOARD LAYOUT

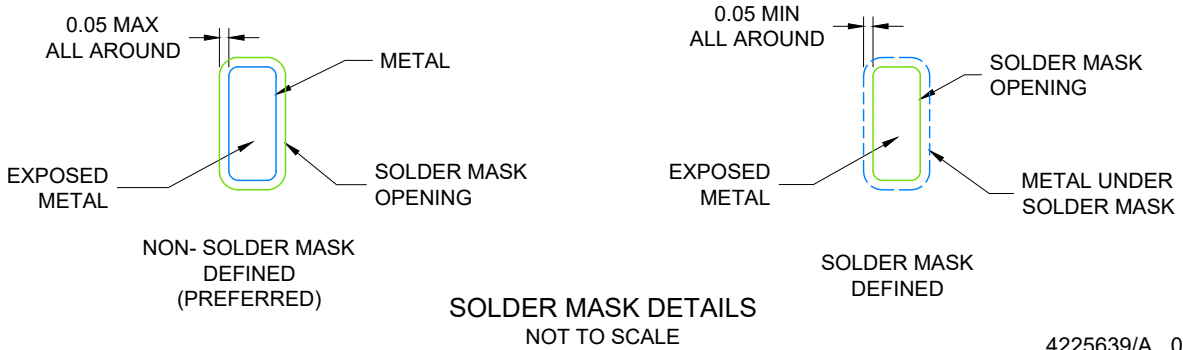
RQY0009A

VQFN-HR - 1 mm max height

PLASTIC QUAD FLATPACK- NO LEAD



LAND PATTERN EXAMPLE  
EXPOSED METAL SHOWN  
SCALE: 25X



SOLDER MASK DETAILS  
NOT TO SCALE

4225639/A 03/2020

NOTES: (continued)

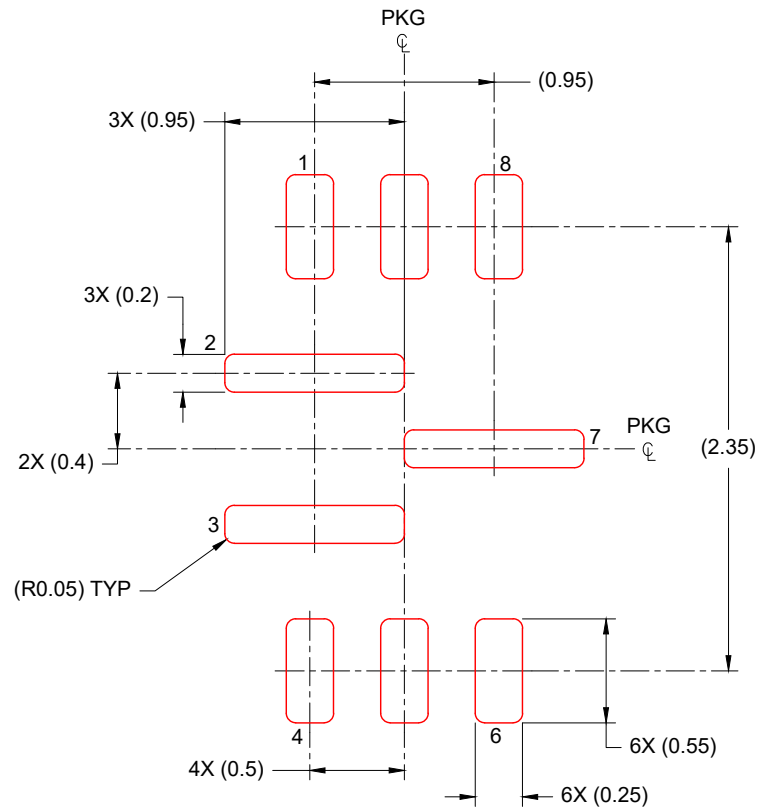
- 3. For more information, see Texas Instruments literature number SLUA271 ([www.ti.com/lit/sluea271](http://www.ti.com/lit/sluea271)).
- 4. Solder mask tolerances between and around signal pads can vary based on board fabrication site.

# EXAMPLE STENCIL DESIGN

RQY0009A

VQFN-HR - 1 mm max height

PLASTIC QUAD FLATPACK- NO LEAD



SOLDER PASTE EXAMPLE  
BASED ON 0.1mm THICK STENCIL  
SCALE: 25X

4225639/A 03/2020

NOTES: (continued)

5. Laser cutting apertures with trapezoidal walls and rounded corners may offer better paste release. IPC-7525 may have alternate design recommendations.

## IMPORTANT NOTICE AND DISCLAIMER

TI PROVIDES TECHNICAL AND RELIABILITY DATA (INCLUDING DATA SHEETS), DESIGN RESOURCES (INCLUDING REFERENCE DESIGNS), APPLICATION OR OTHER DESIGN ADVICE, WEB TOOLS, SAFETY INFORMATION, AND OTHER RESOURCES "AS IS" AND WITH ALL FAULTS, AND DISCLAIMS ALL WARRANTIES, EXPRESS AND IMPLIED, INCLUDING WITHOUT LIMITATION ANY IMPLIED WARRANTIES OF MERCHANTABILITY, FITNESS FOR A PARTICULAR PURPOSE OR NON-INFRINGEMENT OF THIRD PARTY INTELLECTUAL PROPERTY RIGHTS.

These resources are intended for skilled developers designing with TI products. You are solely responsible for (1) selecting the appropriate TI products for your application, (2) designing, validating and testing your application, and (3) ensuring your application meets applicable standards, and any other safety, security, regulatory or other requirements.

These resources are subject to change without notice. TI grants you permission to use these resources only for development of an application that uses the TI products described in the resource. Other reproduction and display of these resources is prohibited. No license is granted to any other TI intellectual property right or to any third party intellectual property right. TI disclaims responsibility for, and you will fully indemnify TI and its representatives against, any claims, damages, costs, losses, and liabilities arising out of your use of these resources.

TI's products are provided subject to [TI's Terms of Sale](#) or other applicable terms available either on [ti.com](https://www.ti.com) or provided in conjunction with such TI products. TI's provision of these resources does not expand or otherwise alter TI's applicable warranties or warranty disclaimers for TI products.

TI objects to and rejects any additional or different terms you may have proposed.

Mailing Address: Texas Instruments, Post Office Box 655303, Dallas, Texas 75265

Copyright © 2025, Texas Instruments Incorporated