



**Table of Contents**

<b>1 Overview</b> .....	<b>2</b>
<b>2 Functional Safety Failure In Time (FIT) Rates</b> .....	<b>3</b>
<b>3 Failure Mode Distribution (FMD)</b> .....	<b>4</b>
<b>4 Pin Failure Mode Analysis (Pin FMA)</b> .....	<b>5</b>

**Trademarks**

All trademarks are the property of their respective owners.

## 1 Overview

This document contains information for TPS6281xM (WQFN package) to aid in a functional safety system design. Information provided are:

- Functional Safety Failure In Time (FIT) rates of the semiconductor component estimated by the application of industry reliability standards
- Component failure modes and their distribution (FMD) based on the primary function of the device
- Pin failure mode analysis (Pin FMA)

Figure 1-1 shows the device functional block diagram for reference.

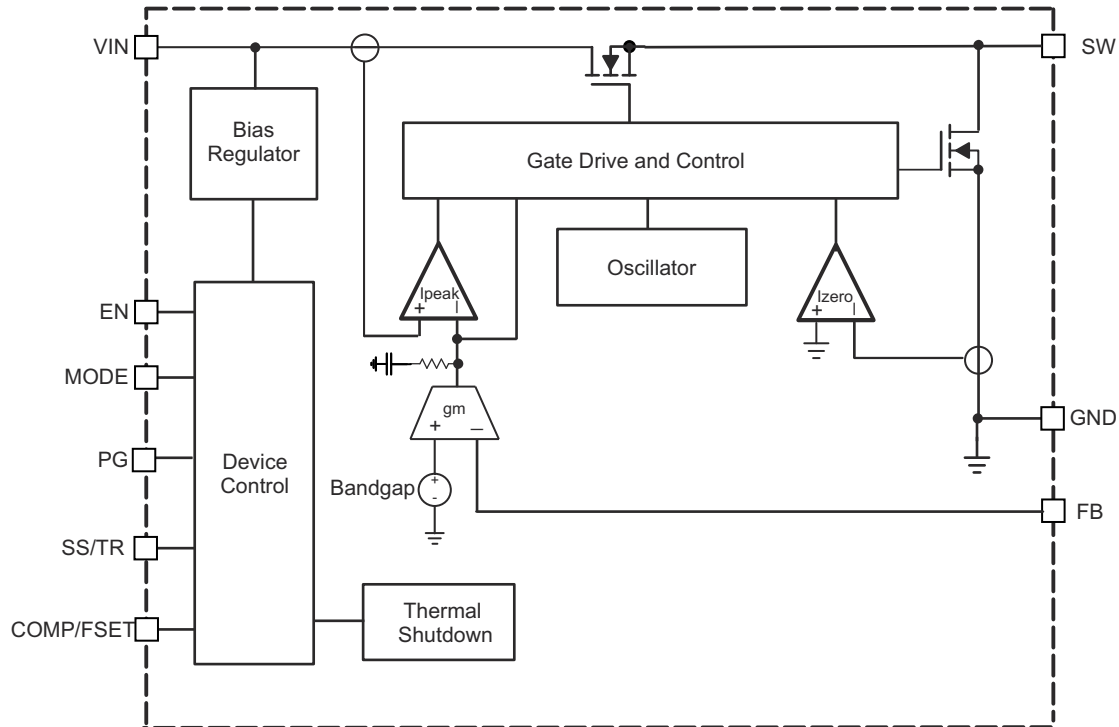

**Figure 1-1. Functional Block Diagram**

TPS6281xM was developed using a quality-managed development process, but was not developed in accordance with the IEC 61508 or ISO 26262 standards.

## 2 Functional Safety Failure In Time (FIT) Rates

This section provides Functional Safety Failure In Time (FIT) rates for TPS6281xM based on two different industry-wide used reliability standards:

- [Table 2-1](#) provides FIT rates based on IEC TR 62380 / ISO 26262 part 11
- [Table 2-2](#) provides FIT rates based on the Siemens Norm SN 29500-2

**Table 2-1. Component Failure Rates per IEC TR 62380 / ISO 26262 Part 11**

FIT IEC TR 62380 / ISO 26262	FIT (Failures Per 10 <sup>9</sup> Hours)
Total Component FIT Rate	10
Die FIT Rate	6
Package FIT Rate	4

The failure rate and mission profile information in [Table 2-1](#) comes from the Reliability data handbook IEC TR 62380 / ISO 26262 part 11:

- Mission Profile: Motor Control from Table 11
- Power dissipation: 597 mW
- Climate type: World-wide Table 8
- Package factor ( $\lambda_3$ ): Table 17b
- Substrate Material: FR4
- EOS FIT rate assumed: 0 FIT

**Table 2-2. Component Failure Rates per Siemens Norm SN 29500-2**

Table	Category	Reference FIT Rate	Reference Virtual T <sub>J</sub>
5	CMOS, BICMOS Digital, analog / mixed	25 FIT	55°C

The Reference FIT Rate and Reference Virtual T<sub>J</sub> (junction temperature) in [Table 2-2](#) come from the Siemens Norm SN 29500-2 tables 1 through 5. Failure rates under operating conditions are calculated from the reference failure rate and virtual junction temperature using conversion information in SN 29500-2 section 4.

### 3 Failure Mode Distribution (FMD)

The failure mode distribution estimation for TPS6281xM in [Table 3-1](#) comes from the combination of common failure modes listed in standards such as IEC 61508 and ISO 26262, the ratio of sub-circuit function size and complexity and from best engineering judgment.

The failure modes listed in this section reflect random failure events and do not include failures due to misuse or overstress.

**Table 3-1. Die Failure Modes and Distribution**

Die Failure Modes	Failure Mode Distribution (%)
SW no output	35%
SW output not in specification – voltage or timing	45%
SW power HS or LS FET stuck on	10%
PG false trip or fails to trip	5%
Short circuit any two pins	5%

## 4 Pin Failure Mode Analysis (Pin FMA)

This section provides a Failure Mode Analysis (FMA) for the pins of the TPS6281xM. The failure modes covered in this document include the typical pin-by-pin failure scenarios:

- Pin short-circuited to Ground (see [Table 4-2](#))
- Pin open-circuited (see [Table 4-3](#))
- Pin short-circuited to an adjacent pin (see [Table 4-4](#))
- Pin short-circuited to VIN (see [Table 4-5](#))

[Table 4-2](#) through [Table 4-5](#) also indicate how these pin conditions can affect the device as per the failure effects classification in [Table 4-1](#).

**Table 4-1. TI Classification of Failure Effects**

Class	Failure Effects
A	Potential device damage that affects functionality
B	No device damage, but loss of functionality
C	No device damage, but performance degradation
D	No device damage, no impact to functionality or performance

[Figure 4-1](#) shows the TPS6281xM pin diagram. For a detailed description of the device pins please refer to the *Pin Configuration and Functions* section in the TPS6281xM [data sheet](#).

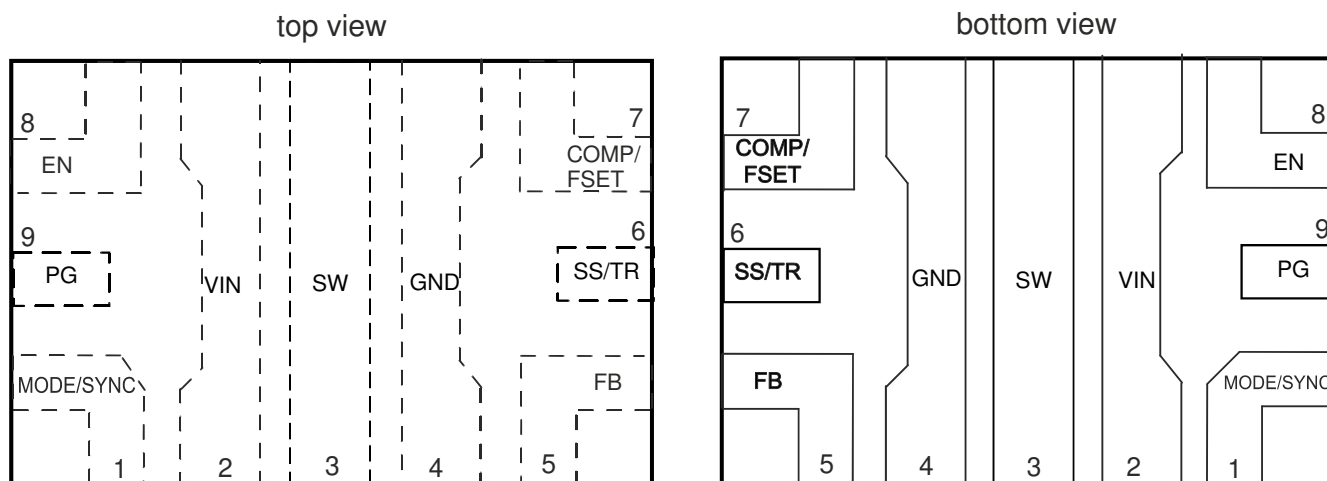

**Figure 4-1. Pin Diagram**

Following are the assumptions of use and the device configuration assumed for the pin FMA in this section:

- Assumption the device is running in the typical application, please refer to the 'Simplified Schematics' on the 1st page in the TPS6281xM [datasheet](#).

**Table 4-2. Pin FMA for Device Pins Short-Circuited to Ground**

Pin Name	Pin No.	Description of Potential Failure Effect(s)	Failure Effect Class
MODE/SYNC	1	Normal operation	D
VIN	2	Device does not power up, no output voltage	B
SW	3	Potential device damage	A
GND	4	Normal operation	D
FB	5	100% duty cycle mode, output voltage will follow the input voltage	B
SS/TR	6	Device will not start properly, no output voltage	B
COMP/FSET	7	Normal operation	D
EN	8	Device is disabled, no output voltage	B
PG	9	Normal operation, no power good indication	B

**Table 4-3. Pin FMA for Device Pins Open-Circuited**

Pin Name	Pin No.	Description of Potential Failure Effect(s)	Failure Effect Class
MODE/SYNC	1	Device either operates in forced PWM or power save mode enabled, output voltage is regulated to its nominal value	B
VIN	2	Device does not power up, no output voltage	B
SW	3	No output voltage	B
GND	4	Device does not power up, no output voltage	B
FB	5	100% or 0% duty cycle operation, no regulated output voltage. Output voltage will either follow the input voltage or no output voltage	B
SS/TR	6	Normal operation	D
COMP/FSET	7	Normal operation	D
EN	8	Device is either enabled or disabled, if enabled output voltage is regulated to its nominal value, if disabled no output voltage	B
PG	9	Normal operation	B

**Table 4-4. Pin FMA for Device Pins Short-Circuited to Adjacent Pin**

Pin Name	Pin No.	Shorted to	Description of Potential Failure Effect(s)	Failure Effect Class
MODE/SYNC	1	2	Normal operation	D
VIN	2	3	Potential device damage	A
SW	3	4	Potential device damage	A
GND	4	5	100% duty cycle mode, output voltage will follow the input voltage	B
FB	5	6	0% duty cycle mode, no output voltage	B
SS/TR	6	7	Normal operation	D
COMP/FSET	7	4	Normal operation	D
EN	8	2	Normal operation	D
EN	8	9	Device does not power up, no output voltage	B
PG	9	1	Device operates in forced PWM once PG is high impedance, output voltage is regulated to its nominal value	B

**Table 4-5. Pin FMA for Device Pins Short-Circuited to VIN**

Pin Name	Pin No.	Description of Potential Failure Effect(s)	Failure Effect Class
MODE/SYNC	1	Normal operation	D
VIN	2	Normal operation	D
SW	3	Potential device damage	A
GND	4	Device does not power up, no output voltage	B
FB	5	Potential device damage	A
SS/TR	6	Normal operation	D
COMP/FSET	7	Normal operation	D
EN	8	Normal operation	D
PG	9	Potential device damage	A

## IMPORTANT NOTICE AND DISCLAIMER

TI PROVIDES TECHNICAL AND RELIABILITY DATA (INCLUDING DATASHEETS), DESIGN RESOURCES (INCLUDING REFERENCE DESIGNS), APPLICATION OR OTHER DESIGN ADVICE, WEB TOOLS, SAFETY INFORMATION, AND OTHER RESOURCES "AS IS" AND WITH ALL FAULTS, AND DISCLAIMS ALL WARRANTIES, EXPRESS AND IMPLIED, INCLUDING WITHOUT LIMITATION ANY IMPLIED WARRANTIES OF MERCHANTABILITY, FITNESS FOR A PARTICULAR PURPOSE OR NON-INFRINGEMENT OF THIRD PARTY INTELLECTUAL PROPERTY RIGHTS.

These resources are intended for skilled developers designing with TI products. You are solely responsible for (1) selecting the appropriate TI products for your application, (2) designing, validating and testing your application, and (3) ensuring your application meets applicable standards, and any other safety, security, or other requirements. These resources are subject to change without notice. TI grants you permission to use these resources only for development of an application that uses the TI products described in the resource. Other reproduction and display of these resources is prohibited. No license is granted to any other TI intellectual property right or to any third party intellectual property right. TI disclaims responsibility for, and you will fully indemnify TI and its representatives against, any claims, damages, costs, losses, and liabilities arising out of your use of these resources.

TI's products are provided subject to TI's Terms of Sale (<https://www.ti.com/legal/termsofsale.html>) or other applicable terms available either on [ti.com](https://www.ti.com) or provided in conjunction with such TI products. TI's provision of these resources does not expand or otherwise alter TI's applicable warranties or warranty disclaimers for TI products.

Mailing Address: Texas Instruments, Post Office Box 655303, Dallas, Texas 75265  
Copyright © 2021, Texas Instruments Incorporated