



**Table of Contents**

1 Overview.....	2
2 Functional Safety Failure In Time (FIT) Rates.....	3
3 Failure Mode Distribution (FMD).....	4
4 Pin Failure Mode Analysis (Pin FMA).....	5

**Trademarks**

All trademarks are the property of their respective owners.

**DRAFT ONLY**  
TI Confidential – NDA Restrictions

## 1 Overview

This document contains information for TPSM53602 (B3QFN package) to aid in a functional safety system design. Information provided are:

- Functional Safety Failure In Time (FIT) rates of the semiconductor component estimated by the application of industry reliability standards
- Component failure modes and their distribution (FMD) based on the primary function of the device
- Pin failure mode analysis (Pin FMA)

Figure 1-1 shows the device functional block diagram for reference.

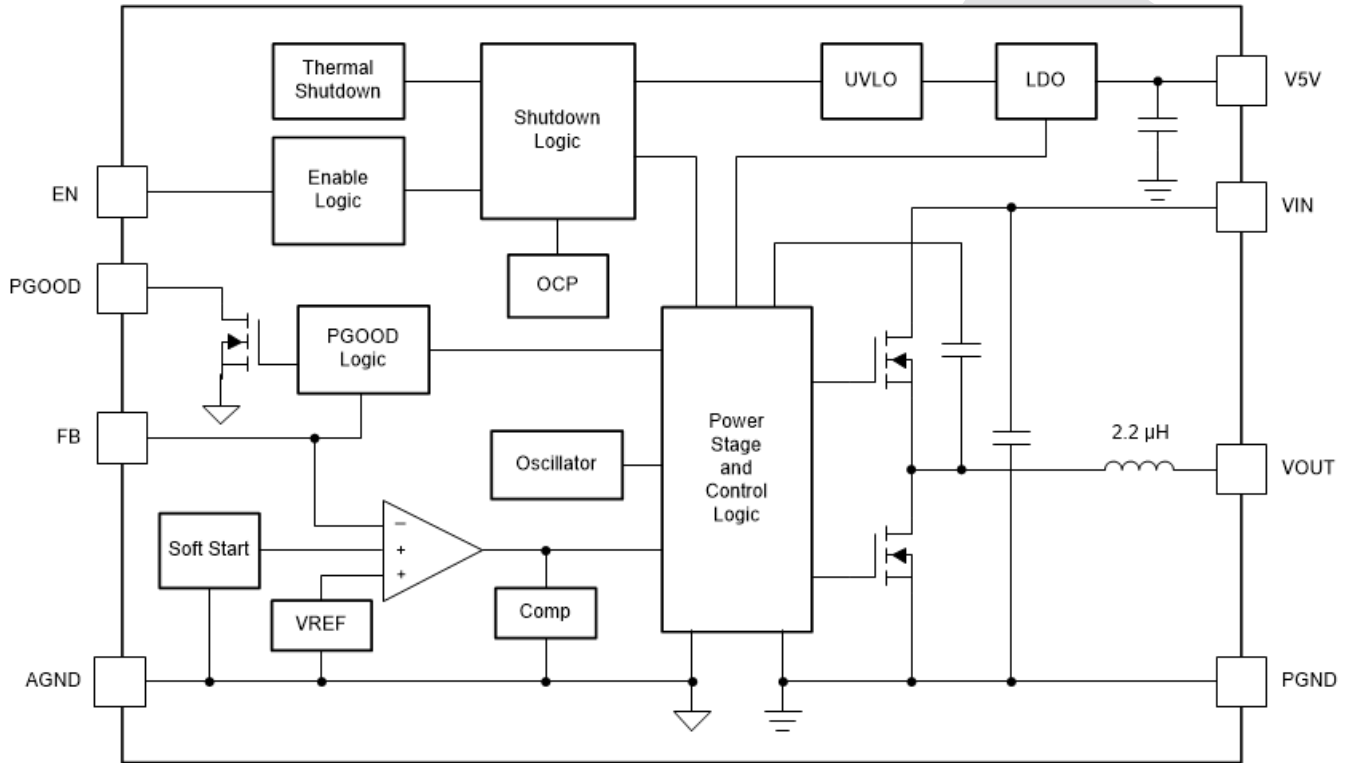

**Figure 1-1. Functional Block Diagram**

TPSM53602 was developed using a quality-managed development process, but was not developed in accordance with the IEC 61508 or ISO 26262 standards.

## 2 Functional Safety Failure In Time (FIT) Rates

This section provides Functional Safety Failure In Time (FIT) rates for TPSM53602 based on two different industry-wide used reliability standards:

- [Table 2-1](#) provides FIT rates based on IEC TR 62380 / ISO 26262 part 11
- [Table 2-2](#) provides FIT rates based on the Siemens Norm SN 29500-2

**Table 2-1. Component Failure Rates per IEC TR 62380 / ISO 26262 Part 11**

FIT IEC TR 62380 / ISO 26262	FIT (Failures Per 10 <sup>9</sup> Hours)
Total Component FIT Rate	22
Die FIT Rate	4
Package FIT Rate	9
Passives FIT Rate	9

The failure rate and mission profile information in [Table 2-1](#) comes from the Reliability data handbook IEC TR 62380 / ISO 26262 part 11:

- Mission Profile: Motor Control from Table 11
- Power dissipation: 555 mW
- Climate type: World-wide Table 8
- Package factor (lambda 3): Table 17b
- Substrate Material: FR4
- EOS FIT rate assumed: 0 FIT

**Table 2-2. Component Failure Rates per Siemens Norm SN 29500-2**

Table	Category	Reference FIT Rate	Reference Virtual T <sub>J</sub>
5	CMOS, BICMOS Digital, analog / mixed	25 FIT	55°C

The Reference FIT Rate and Reference Virtual T<sub>J</sub> (junction temperature) in [Table 2-2](#) come from the Siemens Norm SN 29500-2 tables 1 through 5. Failure rates under operating conditions are calculated from the reference failure rate and virtual junction temperature using conversion information in SN 29500-2 section 4.

### 3 Failure Mode Distribution (FMD)

The failure mode distribution estimation for TPSM53602 in [Table 3-1](#) comes from the combination of common failure modes listed in standards such as IEC 61508 and ISO 26262, the ratio of sub-circuit function size and complexity and from best engineering judgment.

The failure modes listed in this section reflect random failure events and do not include failures due to misuse or overstress.

**Table 3-1. Die Failure Modes and Distribution**

Die Failure Modes	Failure Mode Distribution (%)
No Output Voltage	60%
Output not in specification - voltage or timing	25%
Gate driver stuck on	5%
Power Good - False trip or fails to trip	5%
Short circuit any two pins	5%

The FMD in [Table 3-1](#) excludes short circuit faults across the isolation barrier. Faults for short circuit across the isolation barrier can be excluded according to ISO 61800-5-2:2016 if the following requirements are fulfilled:

1. The signal isolation component is OVC III according to IEC 61800-5-1. If a SELV/PELV power supply is used, pollution degree 2/OVC II applies. All requirements of IEC 61800-5-1:2007, 4.3.6 apply.
2. Measures are taken to ensure that an internal failure of the signal isolation component cannot result in excessive temperature of its insulating material.

Creepage and clearance requirements should be applied according to the specific equipment isolation standards of an application. Care should be taken to maintain the creepage and clearance distance of a board design to ensure that the mounting pads of the isolator on the printed-circuit board do not reduce this distance.

DRAFT

TI Confidential – NDA Resolutions

## 4 Pin Failure Mode Analysis (Pin FMA)

This section provides a Failure Mode Analysis (FMA) for the pins of the TPSM53602. The failure modes covered in this document include the typical pin-by-pin failure scenarios:

- Pin short-circuited to Ground (see [Table 4-2](#))
- Pin open-circuited (see [Table 4-3](#))
- Pin short-circuited to an adjacent pin (see [Table 4-4](#))
- Pin short-circuited to supply (see [Table 4-5](#))

[Table 4-2](#) through [Table 4-5](#) also indicate how these pin conditions can affect the device as per the failure effects classification in [Table 4-1](#).

**Table 4-1. TI Classification of Failure Effects**

Class	Failure Effects
A	Potential device damage that affects functionality
B	No device damage, but loss of functionality
C	No device damage, but performance degradation
D	No device damage, no impact to functionality or performance

[Figure 4-1](#) shows the TPSM53602 pin diagram. For a detailed description of the device pins please refer to the *Pin Configuration and Functions* section in the TPSM53602 data sheet.

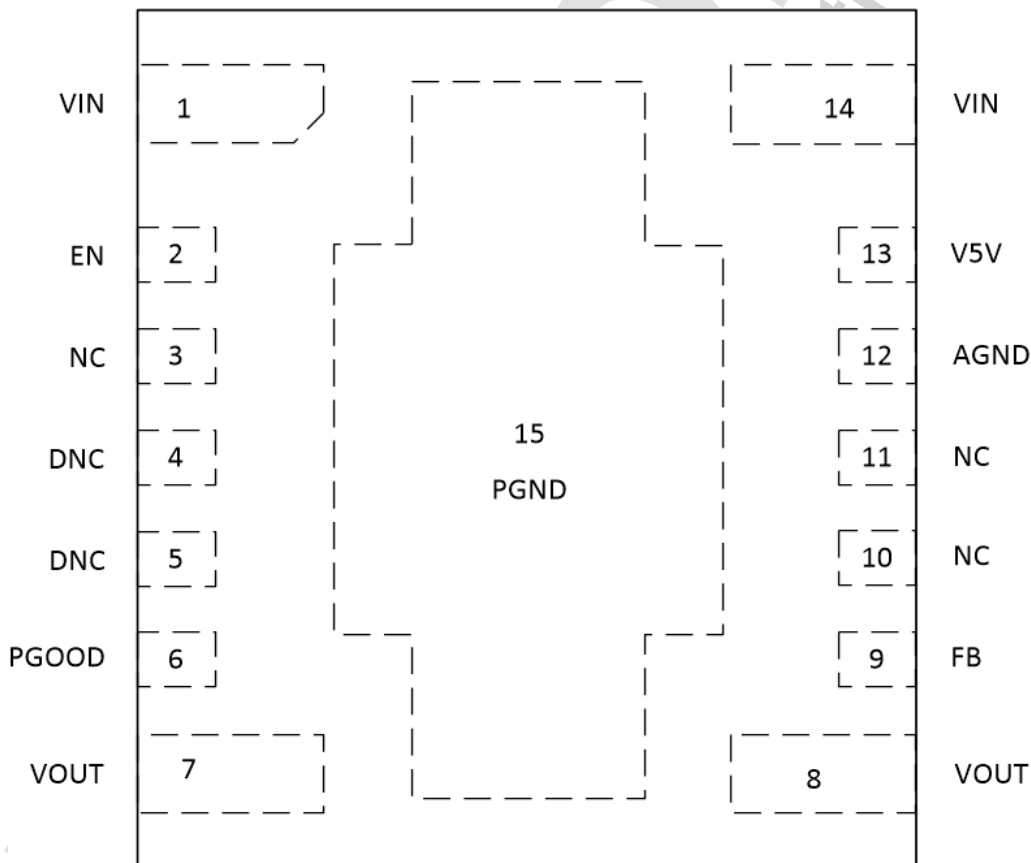

**Figure 4-1. Pin Diagram**

Following are the assumptions of use and the device configuration assumed for the pin FMA in this section:

- Application circuit, as per the [TPSM53602 data sheet](#) is used.

**Table 4-2. Pin FMA for Device Pins Short-Circuited to Ground**

Pin Name	Pin No.	Description of Potential Failure Effect(s)	Failure Effect Class
VIN	1, 14	Device will not operate. No output voltage will be generated. Output capacitors will discharge through input short. Large reverse current can damage device.	A
EN	2	Loss of ENABLE functionality. Device will remain in Shutdown mode.	B
NC	3, 10, 11	Not connected to any circuitry within the module; no effect	D
DNC	4, 5	Possible damage to internal circuits	A
PGOOD	6	This is a valid connection for PGOOD output. PGOOD functionality will be lost. Damage to customer components connected to PGOOD input can occur.	B
VOUT	7, 8	Loss of output voltage	B
FB	9	The regulator will operate at maximum duty cycle. Output voltage will rise to nearly the input voltage (VIN) level. Possible damage to customer load, output stage components can occur, or both. No effect on device.	B
AGND	12	No effect	D
V5V	13	Fault mode will shut down device.	B
PGND	15	No effect	D

**Table 4-3. Pin FMA for Device Pins Open-Circuited**

Pin Name	Pin No.	Description of Potential Failure Effect(s)	Failure Effect Class
VIN	1, 14	With both pins open: loss of output voltage. With one pin open: possible device damage.	A
EN	2	Loss of enable functionality. Erratic operation; probable loss of regulation	B
NC	3, 10, 11	Not connected to any circuitry within the module; no effect	D
DNC	4, 5	No effect	D
PGOOD	6	This is a valid connection for the PGOOD output. PGOOD functionality will be lost.	B
VOUT	7, 8	Loss of output voltage	B
FB	9	Loss of output voltage regulation. Output voltage can rise or fall outside of intended regulation window.	B
AGND	12	Loss of output voltage regulation. Possible damage to internal circuits	A
V5V	13	This is a valid connection for V5V pin.	D
PGND	15	Erratic operation; probable loss of regulation. Possible device damage	A

**Table 4-4. Pin FMA for Device Pins Short-Circuited to Adjacent Pin**

Pin Name	Pin No.	Shorted to	Description of Potential Failure Effect(s)	Failure Effect Class
VIN	1	EN	This is a valid input for VIN. Enable functionality will be lost; the device will remain on.	B
EN	2	NC	Loss of enable functionality. Probable loss of regulation	B
NC	3	DNC	NC pin is not connected to any circuitry within the module; no effect	D
DNC	4	DNC	Possible damage to internal circuits	A
DNC	5	PGOOD	Possible damage to internal circuits	A
PGOOD	6	VOUT	Possible damage to internal circuits	A
VOUT	7	PGND	Loss of output voltage	B
VOUT	8	FB	Erratic operation; probable loss of regulation. Damage to internal circuits will occur for VOOUT > 5.5 V.	A
FB	9	NC	NC pin not connected to any circuitry within the module; no effect	D
NC	10	NC	Neither pin connected to any circuitry within the module; no effect	D
NC	11	AGND	NC pin not connected to any circuitry within the module; no effect	D
AGND	12	V5V	Fault mode will shut down device.	B
V5V	13	VIN	Damage to internal circuits for VIN > 5.5 V	A
VIN	14	PGND	Device will not operate. No output voltage will be generated. Output capacitors will discharge through input short. Large reverse current can damage device.	A

**Table 4-5. Pin FMA for Device Pins Short-Circuited to supply**

Pin Name	Pin No.	Description of Potential Failure Effect(s)	Failure Effect Class
VIN	1, 14	No effect.	D
EN	2	No damage to device. Loss of enable functionality.	B
NC	3, 10, 11	No effect.	C
DNC	4, 5	Possible damage to internal circuits.	A
PGOOD	6	Damage to internal circuits.	A
VOUT	7, 8	The output voltage will rise to nearly the level of VIN. Customer load will be damaged. Possible damage to device.	A
FB	9	Damage to internal circuits will occur for VIN > 5.5 V.	A
AGND	12	Possible damage to internal circuits or package.	A
V5V	13	Damage to internal circuits for VIN > 5.5 V.	A
PGND	15	Device will not operate. No output voltage will be generated. Output capacitors will discharge through input short. Large reverse current may damage device.	A

## IMPORTANT NOTICE AND DISCLAIMER

TI PROVIDES TECHNICAL AND RELIABILITY DATA (INCLUDING DATASHEETS), DESIGN RESOURCES (INCLUDING REFERENCE DESIGNS), APPLICATION OR OTHER DESIGN ADVICE, WEB TOOLS, SAFETY INFORMATION, AND OTHER RESOURCES "AS IS" AND WITH ALL FAULTS, AND DISCLAIMS ALL WARRANTIES, EXPRESS AND IMPLIED, INCLUDING WITHOUT LIMITATION ANY IMPLIED WARRANTIES OF MERCHANTABILITY, FITNESS FOR A PARTICULAR PURPOSE OR NON-INFRINGEMENT OF THIRD PARTY INTELLECTUAL PROPERTY RIGHTS.

These resources are intended for skilled developers designing with TI products. You are solely responsible for (1) selecting the appropriate TI products for your application, (2) designing, validating and testing your application, and (3) ensuring your application meets applicable standards, and any other safety, security, or other requirements. These resources are subject to change without notice. TI grants you permission to use these resources only for development of an application that uses the TI products described in the resource. Other reproduction and display of these resources is prohibited. No license is granted to any other TI intellectual property right or to any third party intellectual property right. TI disclaims responsibility for, and you will fully indemnify TI and its representatives against, any claims, damages, costs, losses, and liabilities arising out of your use of these resources.

TI's products are provided subject to TI's Terms of Sale (<https://www.ti.com/legal/termsofsale.html>) or other applicable terms available either on [ti.com](https://www.ti.com) or provided in conjunction with such TI products. TI's provision of these resources does not expand or otherwise alter TI's applicable warranties or warranty disclaimers for TI products.

Mailing Address: Texas Instruments, Post Office Box 655303, Dallas, Texas 75265  
Copyright © 2021, Texas Instruments Incorporated