



Table of Contents

1 Overview.....	2
2 Functional Safety Failure In Time (FIT) Rates.....	3
3 Failure Mode Distribution (FMD).....	4
4 Pin Failure Mode Analysis (Pin FMA).....	5

Trademarks

All trademarks are the property of their respective owners.

1 Overview

This document contains information for the LM5168 and LM5169 (SO PowerPAD package) to aid in a functional safety system design. Information provided are:

- Functional safety failure in time (FIT) rates of the semiconductor component estimated by the application of industry reliability standards
- Component failure modes and their distribution (FMD) based on the primary function of the device
- Pin failure mode analysis (pin FMA)

Figure 1-1 shows the device functional block diagram for reference.

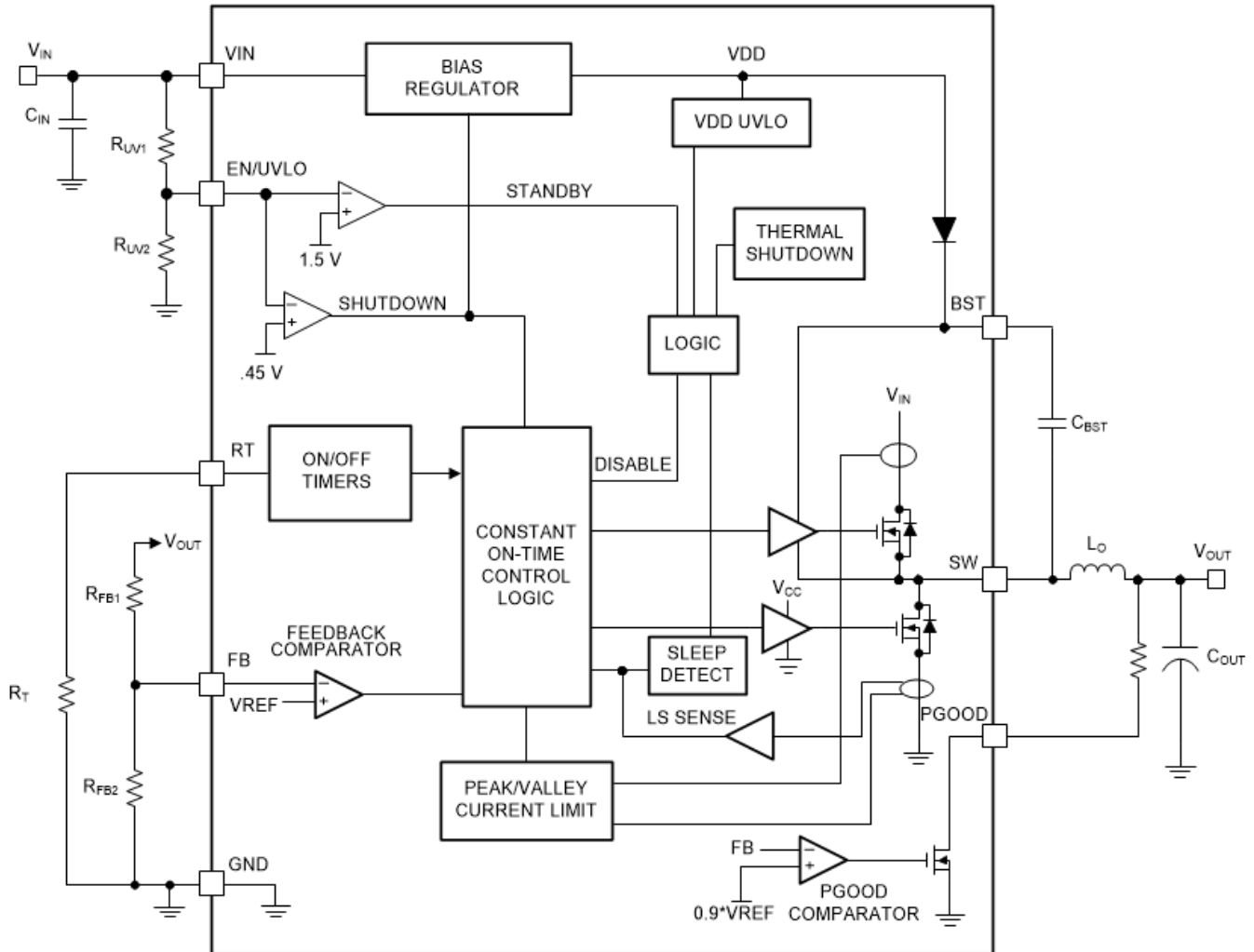

Figure 1-1. Functional Block Diagram

The LM5168 and LM5169 were developed using a quality-managed development process, but was not developed in accordance with the IEC 61508 or ISO 26262 standards.

2 Functional Safety Failure In Time (FIT) Rates

This section provides functional safety failure in time (FIT) rates for the LM5168 and LM5169 based on two different industry-wide used reliability standards:

- [Table 2-1](#) provides FIT rates based on IEC TR 62380 / ISO 26262 part 11
- [Table 2-2](#) provides FIT rates based on the Siemens Norm SN 29500-2

Table 2-1. Component Failure Rates per IEC TR 62380 / ISO 26262 Part 11

FIT IEC TR 62380 / ISO 26262	FIT (Failures Per 10 ⁹ Hours)
Total component FIT rate	13
Die FIT rate	5
Package FIT rate	8

The failure rate and mission profile information in [Table 2-1](#) comes from the reliability data handbook IEC TR 62380 / ISO 26262 part 11:

- Mission profile: motor control from table 11
- Power dissipation: 500 mW
- Climate type: world-wide table 8
- Package factor (lambda 3): table 17b
- Substrate material: FR4
- EOS FIT rate assumed: 0 FIT

Table 2-2. Component Failure Rates per Siemens Norm SN 29500-2

Table	Category	Reference FIT Rate	Reference Virtual T _J
5	CMOS/BICMOS, ASICs, Analog & Mixed HV > 50 V Supply	30 FIT	75°C

The reference FIT rate and reference virtual T_J (junction temperature) in [Table 2-2](#) come from the Siemens Norm SN 29500-2 tables 1 through 5. Failure rates under operating conditions are calculated from the reference failure rate and virtual junction temperature using conversion information in SN 29500-2 section 4.

3 Failure Mode Distribution (FMD)

The failure mode distribution estimation for the LM5168 and LM5169 in [Table 3-1](#) comes from the combination of common failure modes listed in standards such as IEC 61508 and ISO 26262, the ratio of sub-circuit function size and complexity, and from best engineering judgment.

The failure modes listed in this section reflect random failure events and do not include failures resulting from misuse or overstress.

Table 3-1. Die Failure Modes and Distribution

Die Failure Modes	Failure Mode Distribution (%)
No SW Output	45
SW output not in specification - voltage or timing	45
SW driver stuck on	5
PGOOD false trip or fails to trip	5

The FMD in [Table 3-1](#) excludes short-circuit faults across the isolation barrier. Faults for short circuits across the isolation barrier can be excluded according to ISO 61800-5-2:2016 if the following requirements are fulfilled:

1. The signal isolation component is OVC III according to IEC 61800-5-1. If a safety-separated extra low voltage (SELV) or protective extra low voltage (PELV) power supply is used, pollution degree 2 / OVC II applies. All requirements of IEC 61800-5-1:2007, 4.3.6 apply.
2. Measures are taken to ensure that an internal failure of the signal isolation component cannot result in excessive temperature of its insulating material.

Apply creepage and clearance requirements according to the specific equipment isolation standards of an application. Care must be taken to maintain the creepage and clearance distance of a board design to ensure that the mounting pads of the isolator on the printed-circuit board do not reduce this distance.

4 Pin Failure Mode Analysis (Pin FMA)

This section provides a failure mode analysis (FMA) for the pins of the LM5168 and LM5169. The failure modes covered in this document include the typical pin-by-pin failure scenarios:

- Pin short-circuited to ground (see [Table 4-2](#))
- Pin open-circuited (see [Table 4-3](#))
- Pin short-circuited to an adjacent pin (see [Table 4-4](#))
- Pin short-circuited to supply (see [Table 4-5](#))

[Table 4-2](#) through [Table 4-5](#) also indicate how these pin conditions can affect the device as per the failure effects classification in [Table 4-1](#).

Table 4-1. TI Classification of Failure Effects

Class	Failure Effects
A	Potential device damage that affects functionality.
B	No device damage, but loss of functionality.
C	No device damage, but performance degradation.
D	No device damage, no impact to functionality or performance.

[Figure 4-1](#) shows the LM5168 and LM5169 pin diagram. For a detailed description of the device pins, see the *Pin Configuration and Functions* section in the LM5168 and LM5169 data sheet.

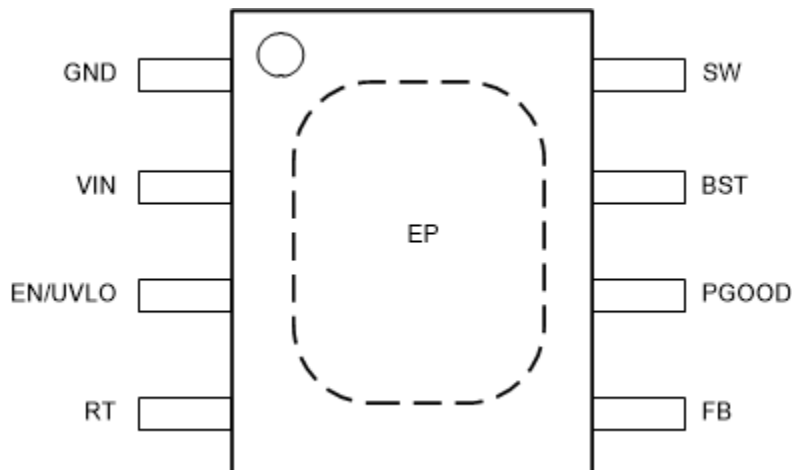

Figure 4-1. Pin Diagram

Following are the assumptions of use and the device configuration assumed for the pin FMA in this section:

- Device used within the *Recommended Operating Conditions* and the *Absolute Maximum Ratings* found in the [LM5169-Q1/LM5168-Q1 0.65-A/0.3-A, 120-V, Step-Down Converter with Fly-Buck™ Converter Capability Data Sheet](#)
- Configuration as shown in the *Example Application Circuit* found in the [LM5169-Q1/LM5168-Q1 0.65-A/0.3-A, 120-V, Step-Down Converter with Fly-Buck™ Converter Capability Data Sheet](#).
- Valid for an ambient temperature of 25°C.
- Faults applied after device start-up is complete.

Table 4-2. Pin FMA for Device Pins Short-Circuited to Ground

Pin Name	Pin No.	Description of Potential Failure Effect(s)	Failure Effect Class
GND	1	Normal operation	D
VIN	2	Input supply shorted to ground. No output voltage	B
EN/UVLO	3	No output voltage. Loss of EN/UVLO functionality	B
RT	4	No or low output voltage	B
FB	5	Output voltage increases to near input voltage level. Possible damage to load	B
PGOOD	6	Normal operation. Loss of PGOOD function	B
BST	7	No output voltage. Possible device damage	A
SW	8	No output voltage. Possible device damage	A

Table 4-3. Pin FMA for Device Pins Open-Circuited

Pin Name	Pin No.	Description of Potential Failure Effect(s)	Failure Effect Class
GND	1	No output voltage	B
VIN	2	No output voltage	B
EN/UVLO	3	No output voltage. Loss of EN/UVLO functionality	B
RT	4	Output voltage out of regulation. Possible damage to load	B
FB	5	Output voltage out of regulation. Possible damage to load	B
PGOOD	6	Normal operation. Loss of PGOOD function	B
BST	7	No output voltage	B
SW	8	No output voltage	B

Table 4-4. Pin FMA for Device Pins Short-Circuited to Adjacent Pin

Pin Name	Pin No.	Shorted to	Description of Potential Failure Effect(s)	Failure Effect Class
GND	1	2, VIN	No output voltage. Input supply shorted to ground.	B
VIN	2	3, EN/UVLO	Normal operation. Loss of EN/UVLO functionality	B
EN/UVLO	3	4, RT	No output voltage. Possible device damage	A
FB	5	6, PGOOD	Output voltage out of regulation. Possible damage to load	B
PGOOD	6	7, BST	No output voltage	B
BST	7	8, SW	No output voltage	B

Table 4-5. Pin FMA for Device Pins Short-Circuited to VIN

Pin Name	Pin No.	Description of Potential Failure Effect(s)	Failure Effect Class
GND	1	Input supply shorted. No output voltage	B
VIN	2	Normal operation	D
EN/UVLO	3	Normal operation. EN/UVLO functionality lost	B
RT	4	No output voltage. Device damage	A
FB	5	No output voltage. Device damage	A
PGOOD	6	Loss of PGOOD functionality. Possible device damage	A
BST	7	No output voltage. Device damage	A
SW	8	Output voltage at level of input voltage. Damage to load. Possible device damage	A

IMPORTANT NOTICE AND DISCLAIMER

TI PROVIDES TECHNICAL AND RELIABILITY DATA (INCLUDING DATA SHEETS), DESIGN RESOURCES (INCLUDING REFERENCE DESIGNS), APPLICATION OR OTHER DESIGN ADVICE, WEB TOOLS, SAFETY INFORMATION, AND OTHER RESOURCES "AS IS" AND WITH ALL FAULTS, AND DISCLAIMS ALL WARRANTIES, EXPRESS AND IMPLIED, INCLUDING WITHOUT LIMITATION ANY IMPLIED WARRANTIES OF MERCHANTABILITY, FITNESS FOR A PARTICULAR PURPOSE OR NON-INFRINGEMENT OF THIRD PARTY INTELLECTUAL PROPERTY RIGHTS.

These resources are intended for skilled developers designing with TI products. You are solely responsible for (1) selecting the appropriate TI products for your application, (2) designing, validating and testing your application, and (3) ensuring your application meets applicable standards, and any other safety, security, regulatory or other requirements.

These resources are subject to change without notice. TI grants you permission to use these resources only for development of an application that uses the TI products described in the resource. Other reproduction and display of these resources is prohibited. No license is granted to any other TI intellectual property right or to any third party intellectual property right. TI disclaims responsibility for, and you will fully indemnify TI and its representatives against, any claims, damages, costs, losses, and liabilities arising out of your use of these resources.

TI's products are provided subject to [TI's Terms of Sale](#) or other applicable terms available either on ti.com or provided in conjunction with such TI products. TI's provision of these resources does not expand or otherwise alter TI's applicable warranties or warranty disclaimers for TI products.

TI objects to and rejects any additional or different terms you may have proposed.

Mailing Address: Texas Instruments, Post Office Box 655303, Dallas, Texas 75265
Copyright © 2022, Texas Instruments Incorporated