

# AFE34RF90 Quad Channel 12-Bit 64GSPS RF Sampling AFE

## 1 Features

- [Request full data sheet](#)
- Quad RF sampling 32 to 64GSPS DACs and ADCs
- RF frequency range: DC to >40GHz
- Sub-ADC core sample rate: 8GSPS
- Maximum signal bandwidth:
  - 4T4R: 3.2GHz (4GSPS complex)
  - 2T2R: 6.4GHz (8GSPS complex)
- Input clock: 4 to 8GHz
- ADC performance
  - Noise floor: -154dBFS/Hz
  - IMD3 (-7dBFS each tone, 16.1GHz): -60dBc
- DAC performance
  - NSD (-12dBFS, 16.1GHz): -163dBFS/Hz
  - IMD3 (-7dBFS each tone, 16.1GHz): -60dBc
- DSP blocks
  - Multiband DUC/DDC (phase coherent hopping)
  - PFIR equalizer
  - FFT spectrum analyzer
  - Fractional resampler
- SerDes data interface:
  - JESD204B and JESD204C compatible
  - 16 SerDes transceivers up to 32.5Gbps
  - Subclass 1 multi-device synchronization
- Supply voltages: 0.9V, 1.2V, and 1.8V
- Package: 24mm × 24mm FCBGA, 0.8mm pitch

## 2 Applications

- [Radar](#)
- [Seeker front end](#)
- [Defense radio](#)
- Tactical communications infrastructure
- [Wireless communications test](#)

## 3 Description

The AFE34RF90 is a high performance, wide bandwidth multi-channel transceiver, integrating four 64GSPS RF sampling digital-to-analog converters (DAC) and four 64GSPS RF sampling analog-to-digital converters (ADC). With receiver RF bandwidth of 40GHz and transmitter RF bandwidth of 30GHz, this device enables direct RF sampling in the frequency bands up through Ka-band without the need for additional frequency conversions stages. This improvement in density and flexibility enables high-channel-count, multi-mission systems.

The TX signal paths support interpolation and digital up conversion options that deliver up to 3.2GHz of signal bandwidth for four TX or 6.4GHz for two TX. An advanced digital signal processing block includes a fractional resampler and a PFIR equalizer followed by multiple digital up converters. The output of the DSP block drive a 64GSPS DAC with a mixed mode output option to enhance 2nd Nyquist operation.

Each receiver chain includes a 64GSPS ADC, followed by multiple digital down converters (DDC), PFIR equalizers and a fractional resampler. Each receiver channel has a signal detection and FFT block for spectral analysis that can automatically control the DDC frequency to quickly tune to spectra with interesting signals. The output of the signal processing block can deliver up to 3.2GHz of signal bandwidth for four RX or 6.4GHz for two RX.

The device includes several loopback paths with variable delay and gain, from a super low latency path directly from the ADC to DAC and longer latency paths including frequency translation.

### Package Information

PART NUMBER	PACKAGE <sup>(1)</sup>	PACKAGE SIZE <sup>(2)</sup>
AFE34RF90	FC-BGA	24mm × 24mm

(1) For more information, see [Section 6](#).

(2) The package size (length × width) is a nominal value and includes pins, where applicable.



PRODUCT PREVIEW

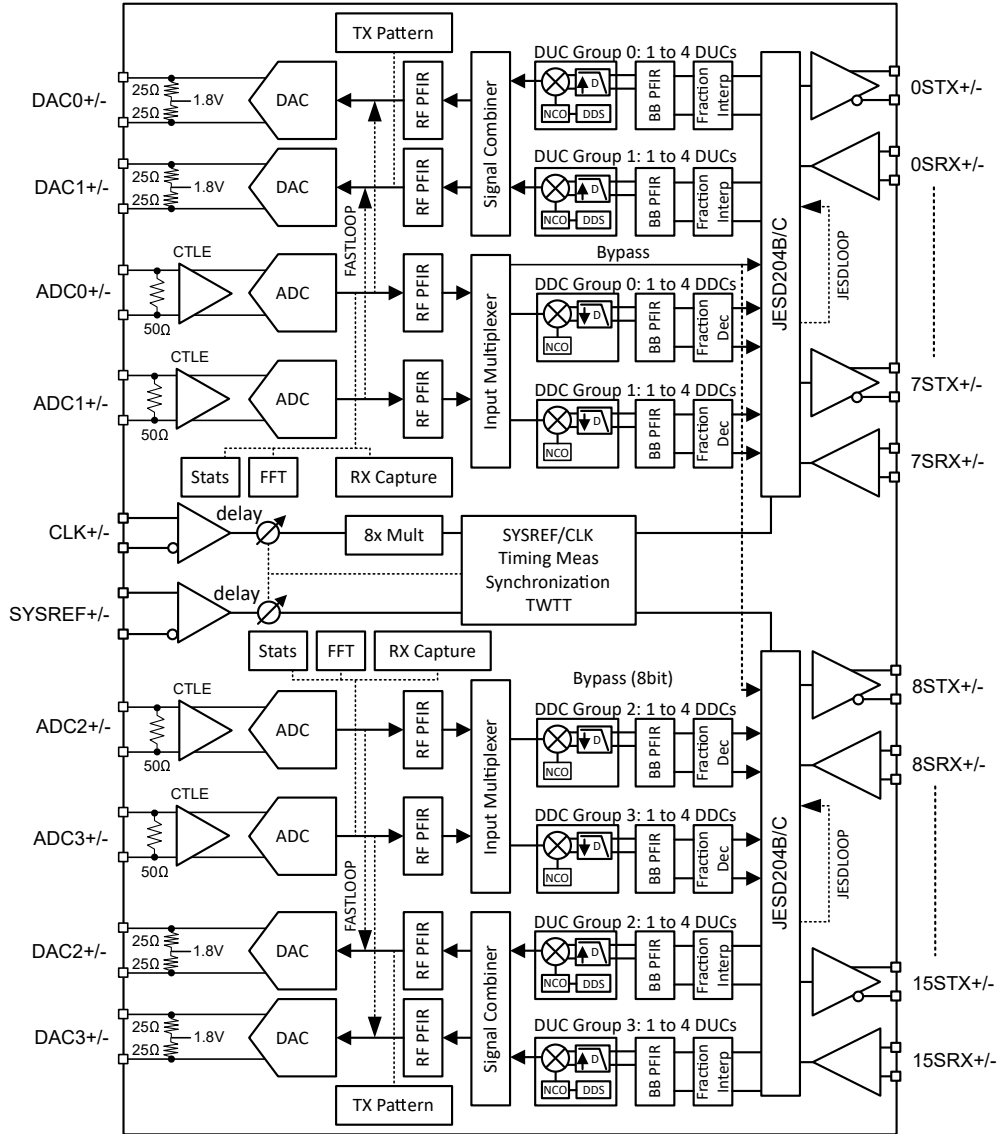

**Functional Block Diagram**

## 4 Device and Documentation Support

### 4.1 Receiving Notification of Documentation Updates

To receive notification of documentation updates, navigate to the device product folder on [ti.com](http://ti.com). Click on *Notifications* to register and receive a weekly digest of any product information that has changed. For change details, review the revision history included in any revised document.

### 4.2 Support Resources

[TI E2E™ support forums](#) are an engineer's go-to source for fast, verified answers and design help — straight from the experts. Search existing answers or ask your own question to get the quick design help you need.

Linked content is provided "AS IS" by the respective contributors. They do not constitute TI specifications and do not necessarily reflect TI's views; see TI's [Terms of Use](#).

### 4.3 Trademarks

TI E2E™ is a trademark of Texas Instruments.  
All trademarks are the property of their respective owners.

### 4.4 Electrostatic Discharge Caution



This integrated circuit can be damaged by ESD. Texas Instruments recommends that all integrated circuits be handled with appropriate precautions. Failure to observe proper handling and installation procedures can cause damage.

ESD damage can range from subtle performance degradation to complete device failure. Precision integrated circuits may be more susceptible to damage because very small parametric changes could cause the device not to meet its published specifications.

### 4.5 Glossary

[TI Glossary](#) This glossary lists and explains terms, acronyms, and definitions.

## 5 Revision History

NOTE: Page numbers for previous revisions may differ from page numbers in the current version.

DATE	REVISION	NOTES
June 2026	*	Product Preview Release

## 6 Mechanical, Packaging, and Orderable Information

The following pages include mechanical, packaging, and orderable information. This information is the most current data available for the designated devices. This data is subject to change without notice and revision of this document. For browser-based versions of this data sheet, refer to the left-hand navigation.

## PACKAGE OPTION ADDENDUM

### PACKAGING INFORMATION

Orderable part number	Status <sup>(1)</sup>	Material type <sup>(2)</sup>	Package   Pins	Package qty   Carrier	RoHS <sup>(3)</sup>	Lead finish/Ball material <sup>(4)</sup>	MSL rating/Peak reflow <sup>(5)</sup>	Op temp (°C)	Part marking
PAFE34RF90AQK	Preview	Preproduction	FCBGA (AQK)   826	44   JEDEC TRAY (5+1)	Yes	SAC305	Level-3-260C-168 HR	-40 to 85	XAFE34RF90

- (1) **Status:** For more details on status, see our [product life cycle](#).
- (2) **Material type:** When designated, preproduction parts are prototypes/experimental devices, and are not yet approved or released for full production. Testing and final process, including without limitation quality assurance, reliability performance testing, and/or process qualification, may not yet be complete, and this item is subject to further changes or possible discontinuation. If available for ordering, purchases will be subject to an additional waiver at checkout, and are intended for early internal evaluation purposes only. These items are sold without warranties of any kind.
- (3) **RoHS values:** Yes, No, RoHS Exempt. See the [TI RoHS Statement](#) for additional information and value definition.
- (4) **Lead finish/Ball material:** Parts may have multiple material finish options. Finish options are separated by a vertical ruled line. Lead finish/Ball material values may wrap to two lines if the finish value exceeds the maximum column width.
- (5) **MSL rating/Peak reflow:** The moisture sensitivity level ratings and peak solder (reflow) temperatures. In the event that a part has multiple moisture sensitivity ratings, only the lowest level per JEDEC standards is shown. Refer to the shipping label for the actual reflow temperature that will be used to mount the part to the printed circuit board.

**Important Information and Disclaimer:** The information provided on this page represents TI's knowledge and belief as of the date that it is provided. TI bases its knowledge and belief on information provided by third parties, and makes no representation or warranty as to the accuracy of such information. Efforts are underway to better integrate information from third parties. TI has taken and continues to take reasonable steps to provide representative and accurate information but may not have conducted destructive testing or chemical analysis on incoming materials and chemicals. TI and TI suppliers consider certain information to be proprietary, and thus CAS numbers and other limited information may not be available for release.

In no event shall TI's liability arising out of such information exceed the total purchase price of the TI part(s) at issue in this document sold by TI to Customer on an annual basis.

**PACKAGING INFORMATION**

Orderable part number	Status (1)	Material type (2)	Package   Pins	Package qty   Carrier	RoHS (3)	Lead finish/ Ball material (4)	MSL rating/ Peak reflow (5)	Op temp (°C)	Part marking (6)
PAFE34RF90AQK	Preview	Preproduction	FCBGA (AQK)   826	1   OTHER	-	Call TI	Call TI	-40 to 85	

(1) **Status:** For more details on status, see our [product life cycle](#).

(2) **Material type:** When designated, preproduction parts are prototypes/experimental devices, and are not yet approved or released for full production. Testing and final process, including without limitation quality assurance, reliability performance testing, and/or process qualification, may not yet be complete, and this item is subject to further changes or possible discontinuation. If available for ordering, purchases will be subject to an additional waiver at checkout, and are intended for early internal evaluation purposes only. These items are sold without warranties of any kind.

(3) **RoHS values:** Yes, No, RoHS Exempt. See the [TI RoHS Statement](#) for additional information and value definition.

(4) **Lead finish/Ball material:** Parts may have multiple material finish options. Finish options are separated by a vertical ruled line. Lead finish/Ball material values may wrap to two lines if the finish value exceeds the maximum column width.

(5) **MSL rating/Peak reflow:** The moisture sensitivity level ratings and peak solder (reflow) temperatures. In the event that a part has multiple moisture sensitivity ratings, only the lowest level per JEDEC standards is shown. Refer to the shipping label for the actual reflow temperature that will be used to mount the part to the printed circuit board.

(6) **Part marking:** There may be an additional marking, which relates to the logo, the lot trace code information, or the environmental category of the part.

Multiple part markings will be inside parentheses. Only one part marking contained in parentheses and separated by a "-" will appear on a part. If a line is indented then it is a continuation of the previous line and the two combined represent the entire part marking for that device.

**Important Information and Disclaimer:** The information provided on this page represents TI's knowledge and belief as of the date that it is provided. TI bases its knowledge and belief on information provided by third parties, and makes no representation or warranty as to the accuracy of such information. Efforts are underway to better integrate information from third parties. TI has taken and continues to take reasonable steps to provide representative and accurate information but may not have conducted destructive testing or chemical analysis on incoming materials and chemicals. TI and TI suppliers consider certain information to be proprietary, and thus CAS numbers and other limited information may not be available for release.

In no event shall TI's liability arising out of such information exceed the total purchase price of the TI part(s) at issue in this document sold by TI to Customer on an annual basis.

## IMPORTANT NOTICE AND DISCLAIMER

TI PROVIDES TECHNICAL AND RELIABILITY DATA (INCLUDING DATASHEETS), DESIGN RESOURCES (INCLUDING REFERENCE DESIGNS), APPLICATION OR OTHER DESIGN ADVICE, WEB TOOLS, SAFETY INFORMATION, AND OTHER RESOURCES "AS IS" AND WITH ALL FAULTS, AND DISCLAIMS ALL WARRANTIES, EXPRESS AND IMPLIED, INCLUDING WITHOUT LIMITATION ANY IMPLIED WARRANTIES OF MERCHANTABILITY, FITNESS FOR A PARTICULAR PURPOSE OR NON-INFRINGEMENT OF THIRD PARTY INTELLECTUAL PROPERTY RIGHTS.

These resources are intended for skilled developers designing with TI products. You are solely responsible for (1) selecting the appropriate TI products for your application, (2) designing, validating and testing your application, and (3) ensuring your application meets applicable standards, and any other safety, security, regulatory or other requirements.

These resources are subject to change without notice. TI grants you permission to use these resources only for development of an application that uses the TI products described in the resource. Other reproduction and display of these resources is prohibited. No license is granted to any other TI intellectual property right or to any third party intellectual property right. TI disclaims responsibility for, and you fully indemnify TI and its representatives against any claims, damages, costs, losses, and liabilities arising out of your use of these resources.

TI's products are provided subject to [TI's Terms of Sale](#), [TI's General Quality Guidelines](#), or other applicable terms available either on [ti.com](http://ti.com) or provided in conjunction with such TI products. TI's provision of these resources does not expand or otherwise alter TI's applicable warranties or warranty disclaimers for TI products. Unless TI explicitly designates a product as custom or customer-specified, TI products are standard, catalog, general purpose devices.

TI objects to and rejects any additional or different terms you may propose.

Copyright © 2026, Texas Instruments Incorporated

Last updated 10/2025