

HD3SS3411 One Channel Differential 2:1 Mux/Demux

1 Features

- Compatible with Multiple Interface Standards Including FPD Link, LVDS, PCIE Gen II, III, XAUI, and USB3.1
- Operates up to 10 Gbps
- Wide -3 dB Differential BW of ~ 7.5 GHz
- Excellent Dynamic Characteristics (at 4 GHz)
 - Insertion Loss = -1.1 dB
 - Return Loss = -11.3 dB
 - Off Isolation = -19 dB
- Bidirectional "Mux/De-Mux" Differential Switch
- Supports Common Mode Voltage 0 V to 2 V
- Single Supply Voltage V_{CC} of 3.3 V \pm 10%
- Industrial Temperature Range of -40°C to 105°C

2 Applications

- Industrial Data Switching
- Desktop and Notebook PCs
- Server/Storage Area Networks
- PCI Express Backplanes
- Shared I/O Ports

3 Description

The HD3SS3411 is a high-speed bi-directional passive switch in multiplexer or demultiplexer configurations. Based on control pin SEL, the device provides switching of differential channels between Port B to Port A or Port C to Port A.

The HD3SS3411 is a generic analog differential passive switch that can work for any high speed interface application as long as it is biased at a common mode voltage range of 0 V to 2 V and has differential signaling with differential amplitude up to 1800 mVpp. The device employs adaptive tracking that ensures the channel remains unchanged for entire common mode voltage range.

Excellent dynamic characteristics of the device allow high speed switching with minimum attenuation to the signal eye diagram with little added jitter. It consumes < 2 mW of power when operational and has a shutdown mode exercisable by OEn pin resulting < 2 μ W.

Device Information⁽¹⁾

PART NUMBER	PACKAGE	BODY SIZE (NOM)
HD3SS3411	WQFN (14)	3.50 mm x 3.50 mm
HD3SS3411I		

(1) For all available packages, see the orderable addendum at the end of the data sheet.

Simplified Schematic

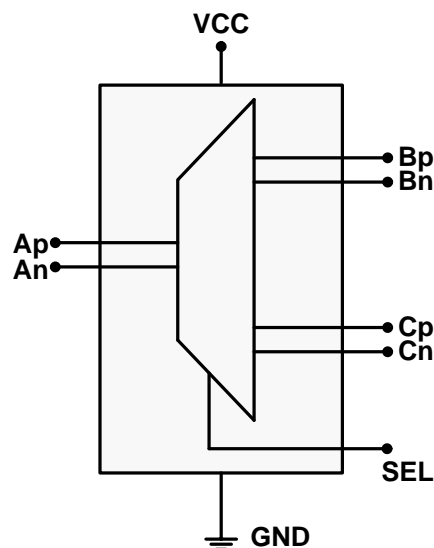

Table of Contents

1 Features 1 2 Applications 1 3 Description 1 4 Revision History 2 5 Pin Configuration and Functions 3 6 Specifications 4 6.1 Absolute Maximum Ratings 4 6.2 ESD Ratings..... 4 6.3 Recommended Operating Conditions 4 6.4 Thermal Information 4 6.5 Electrical Characteristics..... 5 6.6 Timing Requirements 5 6.7 Typical Characteristics 6 7 Detailed Description 7 7.1 Overview 7 7.2 Functional Block Diagram 7 7.3 Feature Description..... 7 7.4 Device Functional Modes..... 8	8 Application Information and Implementation 9 8.1 Application Information..... 9 8.2 Typical Application 9 8.3 Design Requirements..... 10 8.4 Detailed Design Procedure 10 8.5 Application Curves 12 9 Power Supply Recommendations 12 10 Layout 13 10.1 Layout Guidelines 13 10.2 Layout Example 14 11 Device and Documentation Support 15 11.1 Documentation Support 15 11.2 Community Resources..... 15 11.3 Trademarks 15 11.4 Electrostatic Discharge Caution..... 15 11.5 Glossary 15 12 Mechanical, Packaging, and Orderable Information 15
---	---

4 Revision History

DATE	REVISION	NOTES
November 2015	*	Initial release.

5 Pin Configuration and Functions

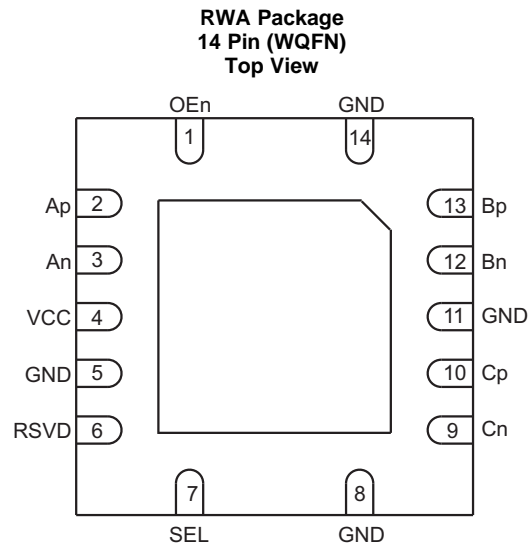

Pin Functions

NAME	NO	TYPE	DESCRIPTION
Ap	2	I/O	Port A, High Speed Positive Signal
An	3	I/O	Port A, High Speed Negative Signal
Bp	13	I/O	Port B, High Speed Positive Signal
Bn	12	I/O	Port B, High Speed Negative Signal
Cp	10	I/O	Port C, High Speed Positive Signal
Cn	9	I/O	Port C, High Speed Negative Signal
GND	5,8,11,14, Pad	G	Ground
OEn	1	I	Active Low Chip Enable L: Normal operation H: Shutdown
RSVD	6	I/O	Reserved Pin – connect or pull-down to GND
SEL	7	I	Port select pin L: Port A to Port B H: Port A to Port C
VCC	4	P	3.3 V power

6 Specifications

6.1 Absolute Maximum Ratings⁽¹⁾

Over operating free-air temperature range (unless otherwise noted)

		MIN	MAX	UNIT
Supply voltage range (V_{CC})	Absolute minimum/maximum supply voltage range	-0.5	4	V
Voltage range	Differential I/O	-0.5	2.5	V
	Control pin	-0.5	$V_{DD} + 0.5$	

- (1) Stresses beyond those listed under *absolute maximum ratings* may cause permanent damage to the device. These are stress ratings only and functional operation of the device at these or any conditions beyond those indicated under *recommended operating conditions* is not implied. Exposure to absolute-maximum-rated conditions for extended periods may affect device reliability.

6.2 ESD Ratings

		VALUE	UNIT
$V_{(ESD)}$ Electrostatic discharge	Human-body model (HBM), per AEC Q100-002 ⁽¹⁾	±2000	V
	Charged-device model (CDM), per AEC Q100-011	±500	

- (1) AEC Q100-002 indicates that HBM stressing shall be in accordance with the ANSI/ESDA/JEDEC JS-001 specification.

6.3 Recommended Operating Conditions

over operating free-air temperature range (unless otherwise noted)

		MIN	NOM	MAX	UNIT
V_{CC}	Supply voltage	3		3.6	V
V_{IH}	Input high voltage (SEL, OEn Pin)	2		V_{CC}	V
V_{IL}	Input low voltage (SEL OEn Pin)	-0.1		0.8	V
V_{Diff}	High speed signal pins differential voltage	0		1.8	V_{PP}
V_{CM}	Common mode voltage (differential pins)	0		2	V
T_A	Operating free-air temperature	-40		105	°C

6.4 Thermal Information

THERMAL METRIC ⁽¹⁾		HD3SS3411	UNIT
		RWA (WQFN)	
		14 PINS	
$R_{\theta JA}$	Junction-to-ambient thermal resistance	50.5	°C/W
$R_{\theta JC(top)}$	Junction-to-case (top) thermal resistance	63.1	
$R_{\theta JB}$	Junction-to-board thermal resistance	26.4	
Ψ_{JT}	Junction-to-top characterization parameter	2.2	
Ψ_{JB}	Junction-to-board characterization parameter	26.5	
$R_{\theta JC(bot)}$	Junction-to-case (bottom) thermal resistance	7.3	

- (1) For more information about traditional and new thermal metrics, see the *IC Package Thermal Metrics* application report, [SPRA953](#).

6.5 Electrical Characteristics

over operating free-air temperature range (unless otherwise noted)

PARAMETER		TEST CONDITIONS	MIN	TYP	MAX	UNITS
I_{CC}	Device active Current	$V_{CC} = 3.3\text{ V}$, $OEn = 0$		0.6	0.8	mA
I_{STDN}	Device shutdown Current	$V_{CC} = 3.3\text{ V}$, $OEn = 0$		0.3	0.6	μA
C_{ON}	Outputs ON Capacitance			0.6		pF
R_{ON}	Output ON resistance	$V_{CC} = 3.3\text{ V}$; $V_{CM} = 0\text{ V to } 2\text{ V}$; $I_O = -8\text{ mA}$		5	8	Ω
ΔR_{ON}	On resistance match between pairs of the same channel	$V_{CC} = 3.3\text{ V}$; $-0.35\text{ V} \leq V_{IN} \leq 2.35\text{ V}$; $I_O = -8\text{ mA}$			0.5	Ω
$R_{(FLAT_ON)}$	On resistance flatness ($R_{ON(MAX)} - R_{ON(MAIN)}$)	$V_{DD} = 3.3\text{ V}$; $-0.35\text{ V} \leq V_{IN} \leq 2.35\text{ V}$			1	Ω
$I_{IH(CTRL)}$	Input high current, control pins (SEL, OEn)				1	μA
$I_{IL(CTRL)}$	Input low current, control pins (SEL, OEn)				1	μA
$I_{IH(HS)}$	Input high current, high speed pins	[A/B/C][p/n] $V_{IN} = 2\text{ V}$ for selected port, A and B with SEL= 0, and A and C with SEL = V_{CC}			1	μA
		[A/B/C][p/n] $V_{IN} = 2\text{ V}$ for non-selected port, C with SEL= 0, and B with SEL = V_{CC} (Note there is a 20 K Ω pull-down in non-selected port)		100	140	μA
$I_{IL(HS)}$	Input low current, high speed pins	[A/B/C][p/n]			1	μA
High Speed Performance						
I_L	Differential Insertion Loss	$f = 0.3\text{ MHz}$		-0.5		dB
		$f = 2.5\text{ GHz}$		-0.7		
		$f = 4\text{ GHz}$		-1.1		
BW	-3 dB Bandwidth			7.5		GHz
R_L	Differential return loss	$f = 0.3\text{ MHz}$		-26.4		dB
		$f = 2.5\text{ GHz}$		-16.6		
		$f = 4\text{ GHz}$		-11.3		
O_I	Differential OFF isolation	$f = 0.3\text{ MHz}$		-75		dB
		$f = 2.5\text{ GHz}$		-22		
		$f = 4\text{ GHz}$		-19		
Xtalk	Differential Crosstalk	$f = 4\text{ GHz}$		-35		dB

6.6 Timing Requirements

		MIN	NOM	MAX	UNIT
t_{PD}	Switch propagation delay			80	ps
t_{SW}	Switching time			0.5	ns
t_{SK_INTRA}	Intra-pair output skew			5	ps

6.7 Typical Characteristics

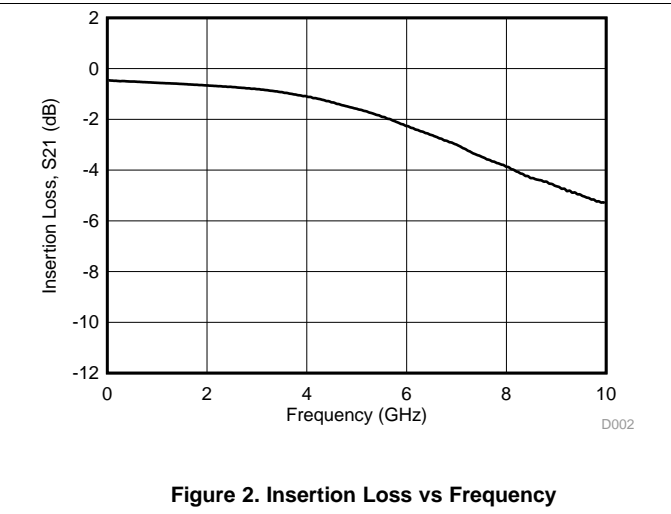
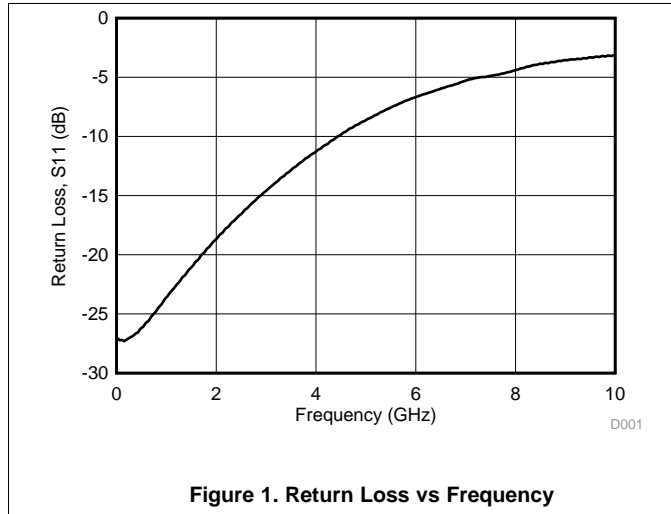

7 Detailed Description

7.1 Overview

The HD3SS3411 is a high-speed bi-directional passive switch in mux or demux configurations. Based on control pin SEL, the device switches one differential channels between Port B or Port C to Port A.

The HD3SS3411 is a generic analog differential passive switch that can work for any high speed interface applications as long as it is biased at a common mode voltage range of 0 V to 2 V and has differential signaling with differential amplitude up to 1800 mVpp. The device employs an adaptive tracking that ensures the channel remains unchanged for entire common mode voltage range.

Table 1. MUX Pin Connections⁽¹⁾

PORT A CHANNEL	PORT B OR PORT C CHANNEL CONNECTED TO PORT A CHANNEL	
	SEL = L	SEL = H
Ap	Bp	Cp
An	Bn	Cn

(1) The HD3SS3411 can tolerate polarity inversions for all differential signals on Ports A, B and C. Care should be taken to ensure the same polarity is maintained on Port A vs. Port B/C.

7.2 Functional Block Diagram

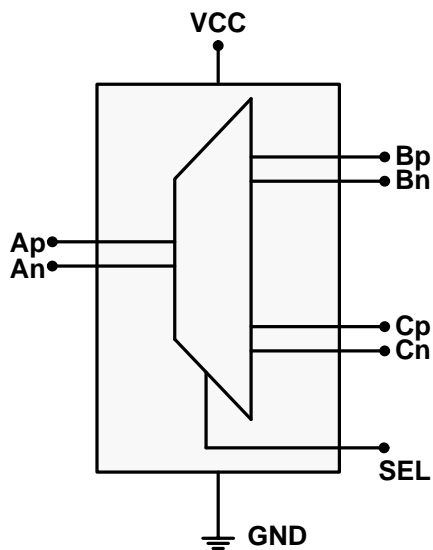

7.3 Feature Description

7.3.1 Output Enable and Power Savings

The HD3SS3411 has two power modes, normal operating mode and shutdown mode. During shutdown mode, the device consumes very-little current to save the maximum power. The OEn control pin is used to toggle between the two modes.

HD3SS3411 consumes < 2 mW of power when operational and has a shutdown mode exercisable by the OEn pin resulting < 20 μ W.

7.4 Device Functional Modes

The OEn control pin selects the functional mode of HD3SS3411. To enter standby/shutdown mode, the OEn control pin is pulled high through a resistor and must remain high. For active/normal operation, the OEn control pin should be pulled low to GND or dynamically controlled to switch between H or L.

Table 2. Device Power Modes

OEn	Device State	Signal Pins
L	Normal	Normal
H	Shutdown	Tri-stated

8 Application Information and Implementation

NOTE

Information in the following applications sections is not part of the TI component specification, and TI does not warrant its accuracy or completeness. TI's customers are responsible for determining suitability of components for their purposes. Customers should validate and test their design implementation to confirm system functionality.

8.1 Application Information

HD3SS3411 mux channels have independent adaptive common mode tracking allowing RX and TX paths to have different common mode voltage simplifying system implementation and avoiding inter-operational issues.

HD3SS3411 mux does not provide common mode biasing for the channel. Therefore, it is required that the device is biased from either side for all active channels.

The HD3SS3411 supports several high-speed data protocols with a differential amplitude of < 1800 mVpp and a common mode voltage of < 2 V, as with USB 3.1 and DisplayPort 1.3. The one select input (SEL) pin can be controlled by an available GPIO pin within a system or from a microcontroller.

8.2 Typical Application

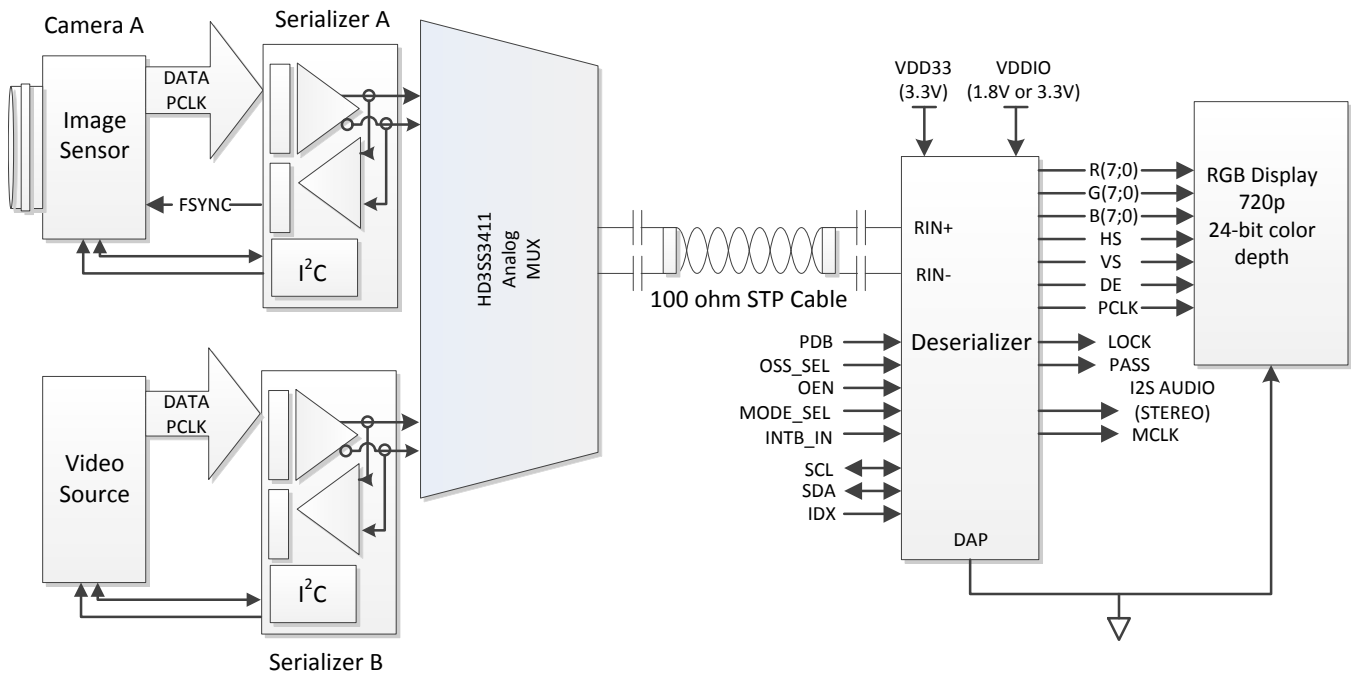

Figure 3. FPD Link III Application

8.3 Design Requirements

For this design example, use the values shown in [Table 3](#).

Table 3. Design Parameters

PARAMETER	VALUE
V_{CC} voltage	3.3 V
Ap/n, Bp/n, Cp/n CM input voltage	0 V to 2 V
SEL/OEn pin max voltage for low	0 V
SEL/OEn pin min voltage for high	3.3 V

8.4 Detailed Design Procedure

8.4.1 AC Coupling Capacitors

Many interfaces require AC coupling between the transmitter and receiver. The 0402 capacitors are the preferred option to provide AC coupling, and the 0603 size capacitors will also work. The 0805 size capacitors and C-packs should be avoided. When placing AC coupling capacitors symmetric placement is best. A capacitor value of 0.1 μF is best and the value should be match for the \pm signal pair. The placement should be along the TX pairs on the system board, which are usually routed on the top layer of the board.

There are several placement options for the AC coupling capacitors. Because the switch requires a bias voltage, the capacitors must only be placed on one side of the switch. If they are placed on both sides of the switch, a biasing voltage should be provided. A few placement options are shown below. In [Figure 4](#), the coupling capacitors are placed between the switch and endpoint. In this situation, the switch is biased by the system/host controller.

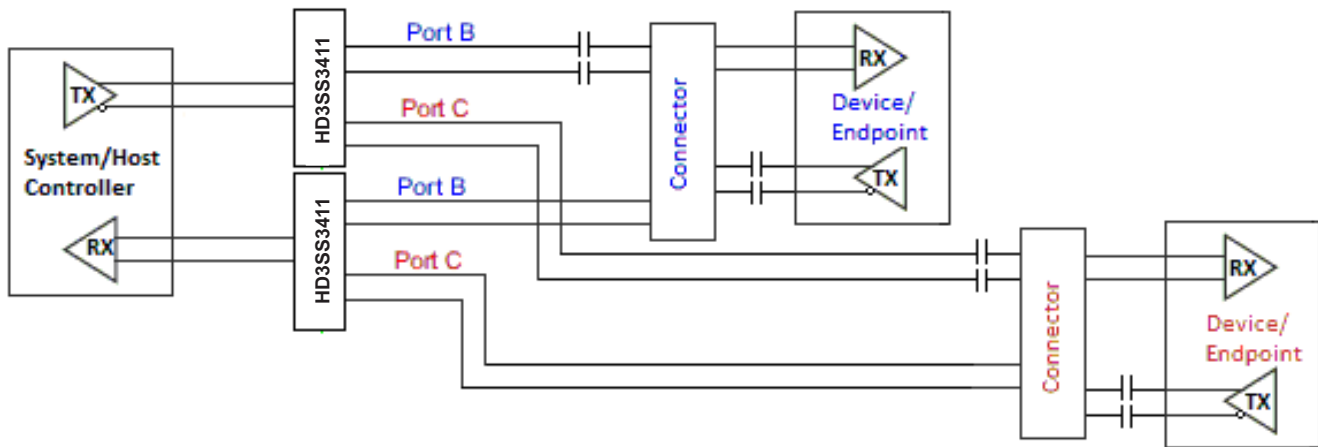

Figure 4. AC Coupling Capacitors Between Switch TX and Endpoint TX

Detailed Design Procedure (continued)

In Figure 5, the coupling capacitors are placed on the host transmit pair and endpoint transmit pair. In this situation, the switch on the top is biased by the endpoint and the lower switch is biased by the host controller.

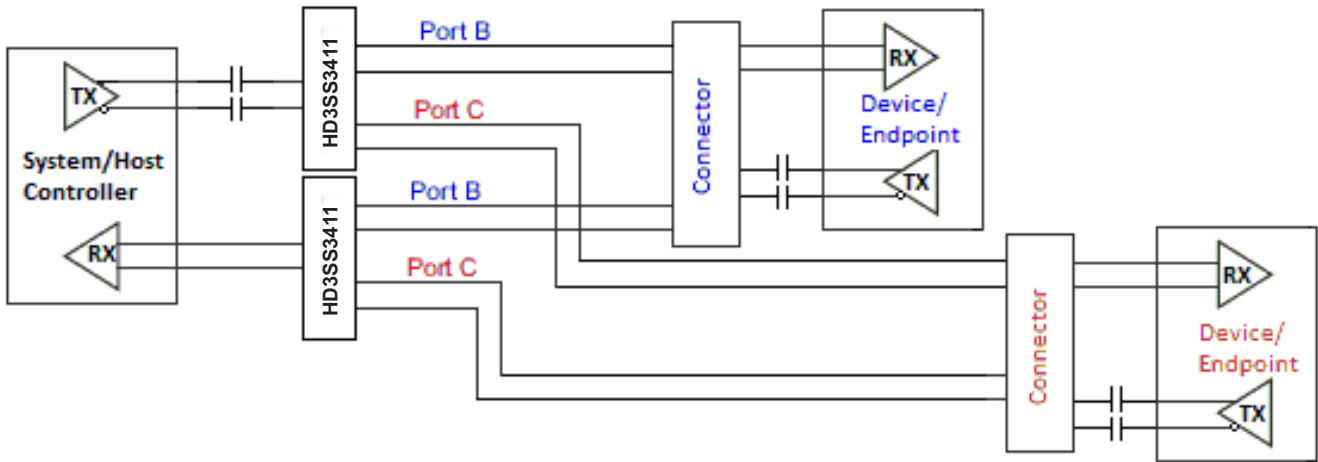

Figure 5. AC Coupling Capacitors on Host TX and Endpoint TX

If the common mode voltage in the system is higher than 2 V, the coupling capacitors are placed on both sides of the switch (shown in Figure 6). A biasing voltage of less than 2 V is required in this case.

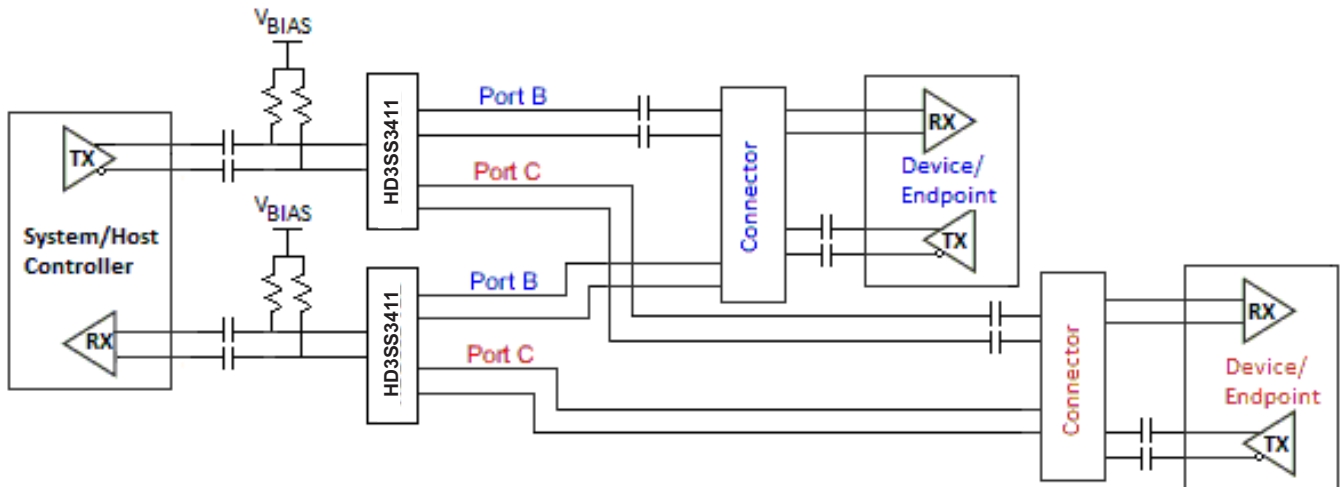

Figure 6. AC Coupling Capacitors on Both Sides of Switch

8.5 Application Curves

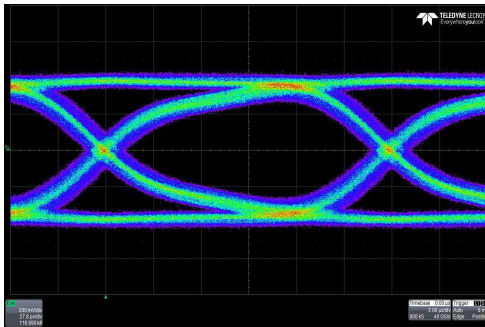

Figure 7. 6 Gbps Source Eye Diagram

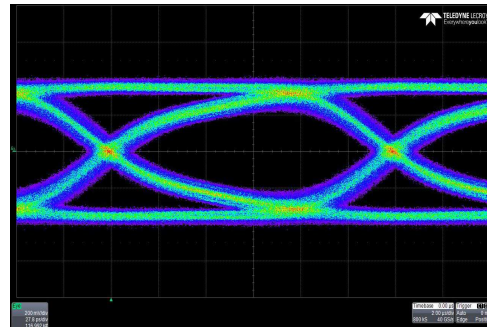

Figure 8. 6 Gbps Output Eye Diagram

9 Power Supply Recommendations

There is no power supply sequence required for HD3SS3411. However, it is recommended that OEn is asserted low after device supply V_{CC} is stable and in specifications. It is also recommended that ample decoupling capacitors are placed at the device V_{CC} near the pin.

10 Layout

10.1 Layout Guidelines

10.1.1 Critical Routes

- The high speed differential signals must be routed with great care to minimize signal quality degradation between the connector and the source or sink of the high speed signals by following the guidelines provided in this document. Depending on the configuration schemes, the speed of each differential pair can reach a maximum speed of 10 Gbps. These signals are to be routed first before other signals with highest priority.
- Each differential pair should be routed together with controlled differential impedance of 85- Ω to 90- Ω and 50- Ω common mode impedance. Keep away from other high speed signals. The number of vias should be kept to minimum. Each pair should be separated from adjacent pairs by at least 3 times the signal trace width. Route all differential pairs on the same group of layers (Outer layers or inner layers) if not on the same layer. No 90 degree turns on any of the differential pairs. If bends are used on high speed differential pairs, the angle of the bend should be greater than 135 degrees.
- Length matching:
 - Keep high speed differential pairs lengths within 5 mil of each other to keep the intra-pair skew minimum. The inter-pair matching of the differential pairs is not as critical as intra-pair matching.
- Keep high speed differential pair traces adjacent to ground plane.
- Do not route differential pairs over any plane split.
- ESD components on the high speed differential lanes should be placed nearest to the connector in a pass through manner without stubs on the differential path.
- For ease of routing, the P and N connection of the USB3.1 differential pairs to the HD3SS3411 pins can be swapped.

10.1.2 General Routing/Placement Rules

- Follow 20H rule (H is the distance to ref-plane) for separation of the high speed trace from the edge of the plane.
- Minimize parallelism of high speed clocks and other periodic signal traces to high speed lines.
- All differential pairs should be routed on the top or bottom layer (microstrip traces) if possible or on the same group of layers. Vias should only be used in the breakout region of the device to route from the top to bottom layer when necessary. Avoid using vias in the main region of the board at all cost. Use a ground reference via next to signal via. Distance between ground reference via and signal need to be calculated to have similar impedance as traces.
- All differential signals should not be routed over plane split. Changing signal layers is preferable to crossing plane splits.
- Use of and proper placement of stitching caps when split plane crossing is unavoidable to account for high frequency return current path.
- Route differential traces over a continuous plane with no interruptions.
- Do not route differential traces under power connectors or other interface connectors, crystals, oscillators, or any magnetic source.
- Route traces away from etching areas like pads, vias, and other signal traces. Try to maintain a 20 mil keep out distance where possible.
- Decoupling caps should be placed next to each power terminal on the HD3SS3411. Care should be taken to minimize the stub length of the trace connecting the capacitor to the power pin.
- Avoid sharing vias between multiple decoupling caps.
- Place vias as close as possible to the decoupling cap solder pad.
- Widen VCC/GND planes to reduce effect of static and dynamic IR drop.

11 Device and Documentation Support

11.1 Documentation Support

11.2 Community Resources

The following links connect to TI community resources. Linked contents are provided "AS IS" by the respective contributors. They do not constitute TI specifications and do not necessarily reflect TI's views; see TI's [Terms of Use](#).

TI E2E™ Online Community *TI's Engineer-to-Engineer (E2E) Community*. Created to foster collaboration among engineers. At e2e.ti.com, you can ask questions, share knowledge, explore ideas and help solve problems with fellow engineers.

Design Support *TI's Design Support* Quickly find helpful E2E forums along with design support tools and contact information for technical support.

11.3 Trademarks

E2E is a trademark of Texas Instruments.
All other trademarks are the property of their respective owners.

11.4 Electrostatic Discharge Caution



These devices have limited built-in ESD protection. The leads should be shorted together or the device placed in conductive foam during storage or handling to prevent electrostatic damage to the MOS gates.

11.5 Glossary

[SLYZ022](#) — *TI Glossary*.

This glossary lists and explains terms, acronyms, and definitions.

12 Mechanical, Packaging, and Orderable Information

The following pages include mechanical, packaging, and orderable information. This information is the most current data available for the designated devices. This data is subject to change without notice and revision of this document. For browser-based versions of this data sheet, refer to the left-hand navigation.

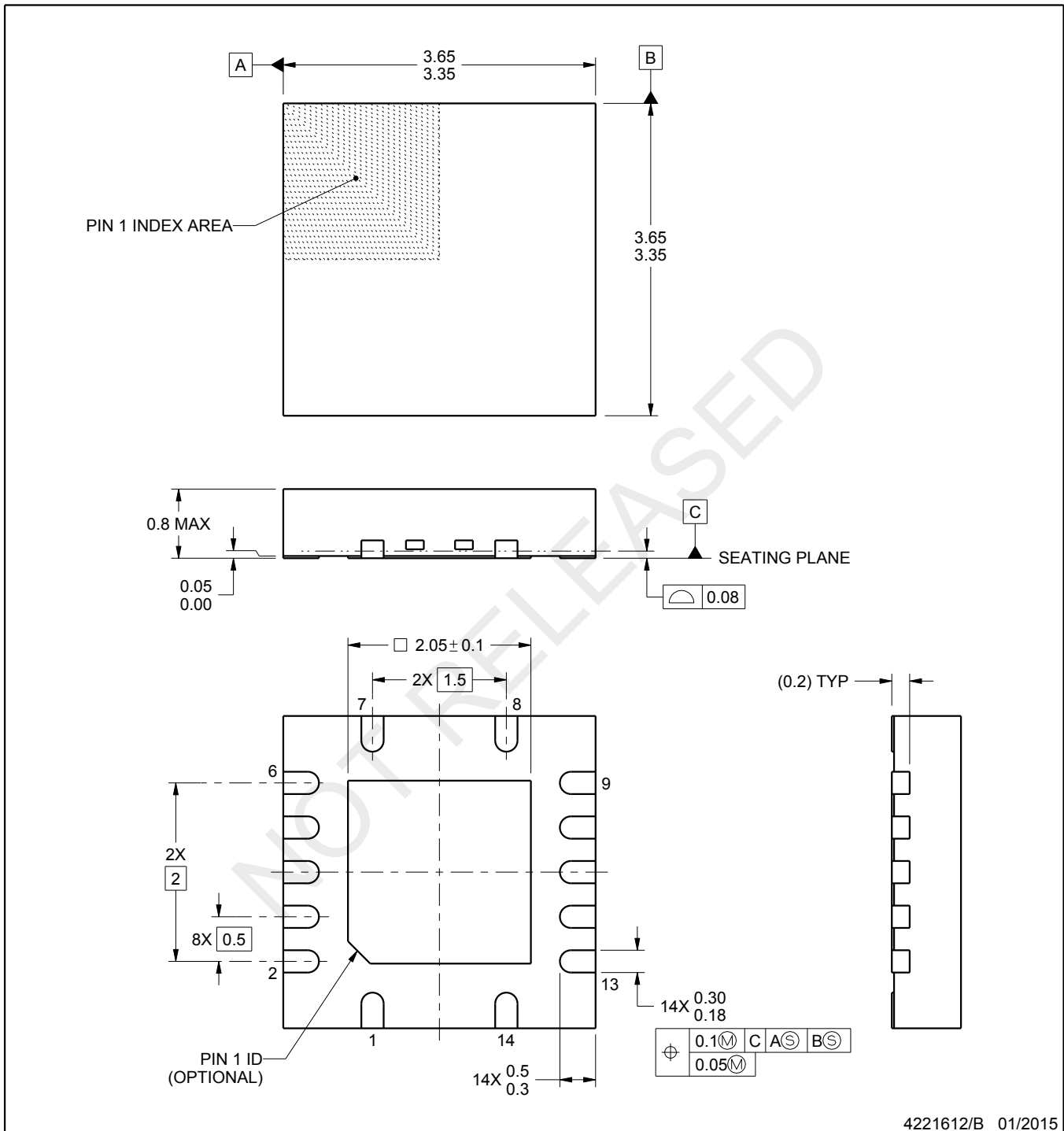
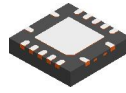

4221612/B 01/2015

NOTES:

1. All linear dimensions are in millimeters. Any dimensions in parenthesis are for reference only. Dimensioning and tolerancing per ASME Y14.5M.
2. This drawing is subject to change without notice.
3. The package thermal pad must be soldered to the printed circuit board for thermal and mechanical performance.

EXAMPLE BOARD LAYOUT

RWA0014A

WQFN - 0.8 mm max height

PLASTIC QUAD FLATPACK - NO LEAD

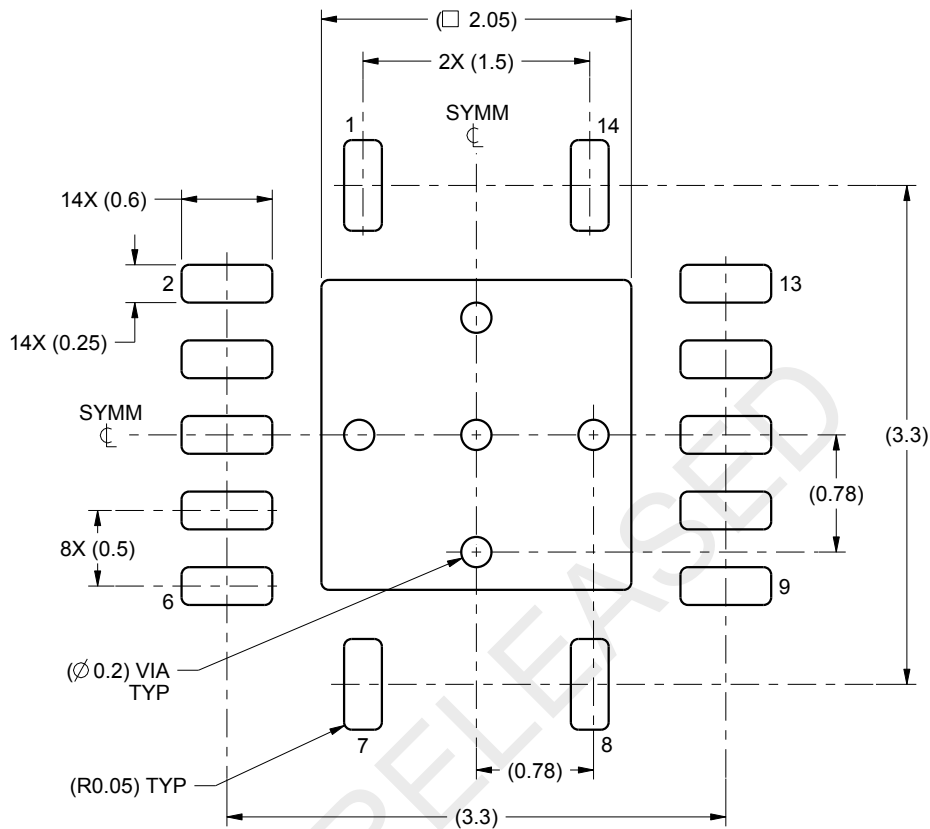

LAND PATTERN EXAMPLE
SCALE:20X

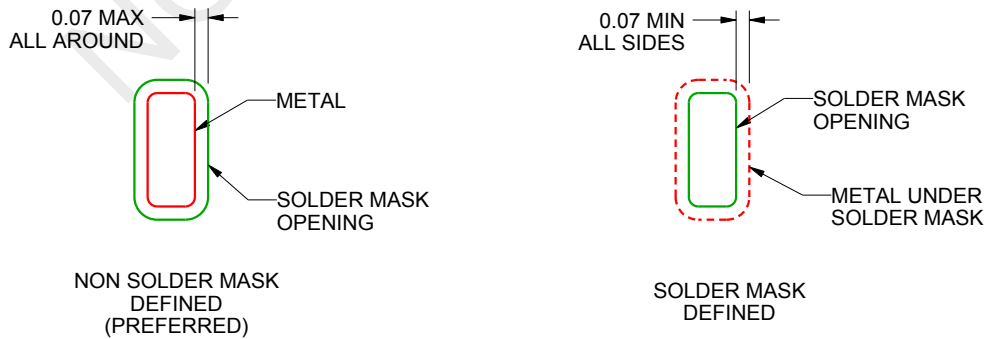

SOLDER MASK DETAILS

4221612/B 01/2015

NOTES: (continued)

- This package is designed to be soldered to a thermal pad on the board. For more information, see Texas Instruments literature number SLUA271 (www.ti.com/lit/sluea271).

EXAMPLE STENCIL DESIGN

RWA0014A

WQFN - 0.8 mm max height

PLASTIC QUAD FLATPACK - NO LEAD

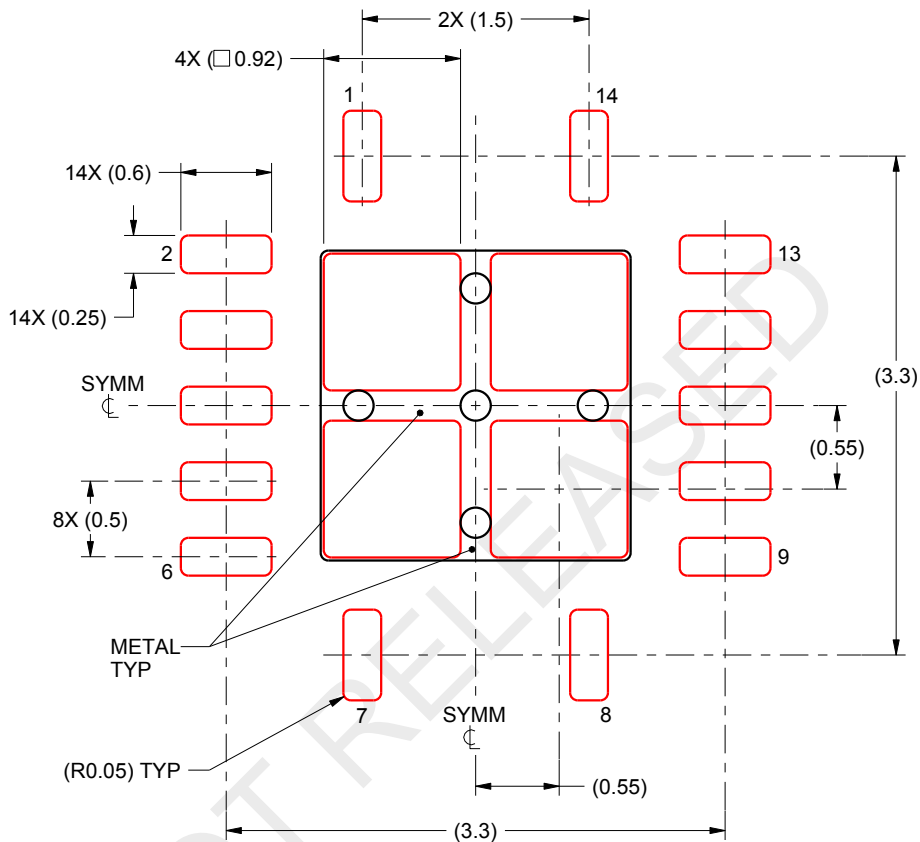

SOLDER PASTE EXAMPLE
BASED ON 0.125 mm THICK STENCIL

EXPOSED PAD
80% PRINTED SOLDER COVERAGE BY AREA
SCALE:20X

4221612/B 01/2015

NOTES: (continued)

5. Laser cutting apertures with trapezoidal walls and rounded corners may offer better paste release. IPC-7525 may have alternate design recommendations.

PACKAGING INFORMATION

Orderable part number	Status (1)	Material type (2)	Package Pins	Package qty Carrier	RoHS (3)	Lead finish/ Ball material (4)	MSL rating/ Peak reflow (5)	Op temp (°C)	Part marking (6)
HD3SS3411IRWAR	Active	Production	WQFN (RWA) 14	3000 LARGE T&R	Yes	NIPDAU	Level-1-260C-UNLIM	-40 to 105	34111
HD3SS3411IRWAR.B	Active	Production	WQFN (RWA) 14	3000 LARGE T&R	Yes	NIPDAU	Level-1-260C-UNLIM	-40 to 105	34111
HD3SS3411IRWARG4	Active	Production	WQFN (RWA) 14	3000 LARGE T&R	Yes	NIPDAU	Level-1-260C-UNLIM	-40 to 105	34111
HD3SS3411IRWARG4.B	Active	Production	WQFN (RWA) 14	3000 LARGE T&R	Yes	NIPDAU	Level-1-260C-UNLIM	-40 to 105	34111
HD3SS3411IRWAT	Active	Production	WQFN (RWA) 14	250 SMALL T&R	Yes	NIPDAU	Level-1-260C-UNLIM	-40 to 105	34111
HD3SS3411IRWAT.B	Active	Production	WQFN (RWA) 14	250 SMALL T&R	Yes	NIPDAU	Level-1-260C-UNLIM	-40 to 105	34111

(1) **Status:** For more details on status, see our [product life cycle](#).

(2) **Material type:** When designated, preproduction parts are prototypes/experimental devices, and are not yet approved or released for full production. Testing and final process, including without limitation quality assurance, reliability performance testing, and/or process qualification, may not yet be complete, and this item is subject to further changes or possible discontinuation. If available for ordering, purchases will be subject to an additional waiver at checkout, and are intended for early internal evaluation purposes only. These items are sold without warranties of any kind.

(3) **RoHS values:** Yes, No, RoHS Exempt. See the [TI RoHS Statement](#) for additional information and value definition.

(4) **Lead finish/Ball material:** Parts may have multiple material finish options. Finish options are separated by a vertical ruled line. Lead finish/Ball material values may wrap to two lines if the finish value exceeds the maximum column width.

(5) **MSL rating/Peak reflow:** The moisture sensitivity level ratings and peak solder (reflow) temperatures. In the event that a part has multiple moisture sensitivity ratings, only the lowest level per JEDEC standards is shown. Refer to the shipping label for the actual reflow temperature that will be used to mount the part to the printed circuit board.

(6) **Part marking:** There may be an additional marking, which relates to the logo, the lot trace code information, or the environmental category of the part.

Multiple part markings will be inside parentheses. Only one part marking contained in parentheses and separated by a "~" will appear on a part. If a line is indented then it is a continuation of the previous line and the two combined represent the entire part marking for that device.

Important Information and Disclaimer: The information provided on this page represents TI's knowledge and belief as of the date that it is provided. TI bases its knowledge and belief on information provided by third parties, and makes no representation or warranty as to the accuracy of such information. Efforts are underway to better integrate information from third parties. TI has taken and continues to take reasonable steps to provide representative and accurate information but may not have conducted destructive testing or chemical analysis on incoming materials and chemicals. TI and TI suppliers consider certain information to be proprietary, and thus CAS numbers and other limited information may not be available for release.

In no event shall TI's liability arising out of such information exceed the total purchase price of the TI part(s) at issue in this document sold by TI to Customer on an annual basis.

OTHER QUALIFIED VERSIONS OF HD3SS3411 :

- Automotive : [HD3SS3411-Q1](#)

NOTE: Qualified Version Definitions:

- Automotive - Q100 devices qualified for high-reliability automotive applications targeting zero defects

EXAMPLE BOARD LAYOUT

RWA0014A

WQFN - 0.8 mm max height

PLASTIC QUAD FLATPACK - NO LEAD

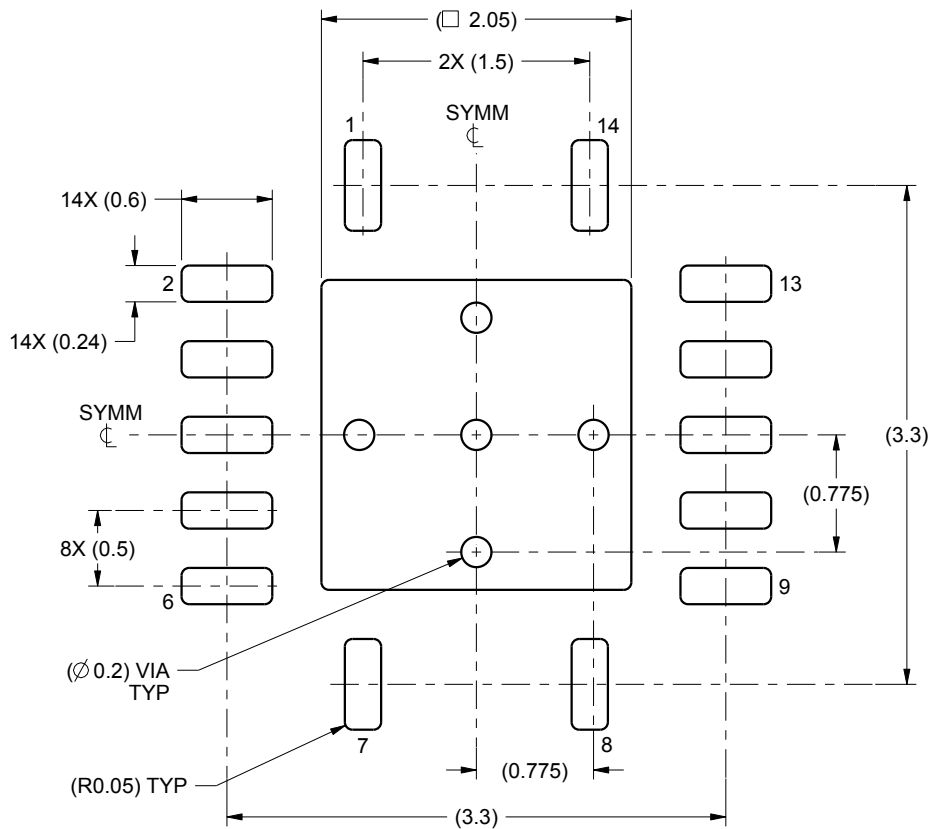

LAND PATTERN EXAMPLE
SCALE:20X

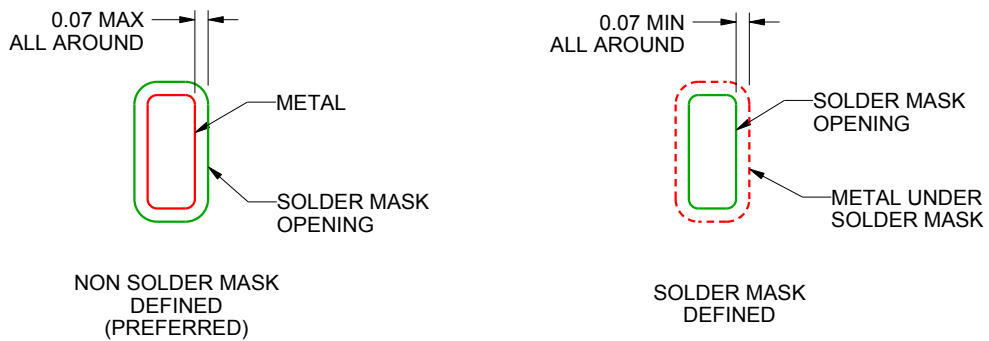

SOLDER MASK DETAILS

4221612/B 02/2015

NOTES: (continued)

4. This package is designed to be soldered to a thermal pad on the board. For more information, see Texas Instruments literature number SLUA271 (www.ti.com/lit/sl原因271).

EXAMPLE STENCIL DESIGN

RWA0014A

WQFN - 0.8 mm max height

PLASTIC QUAD FLATPACK - NO LEAD

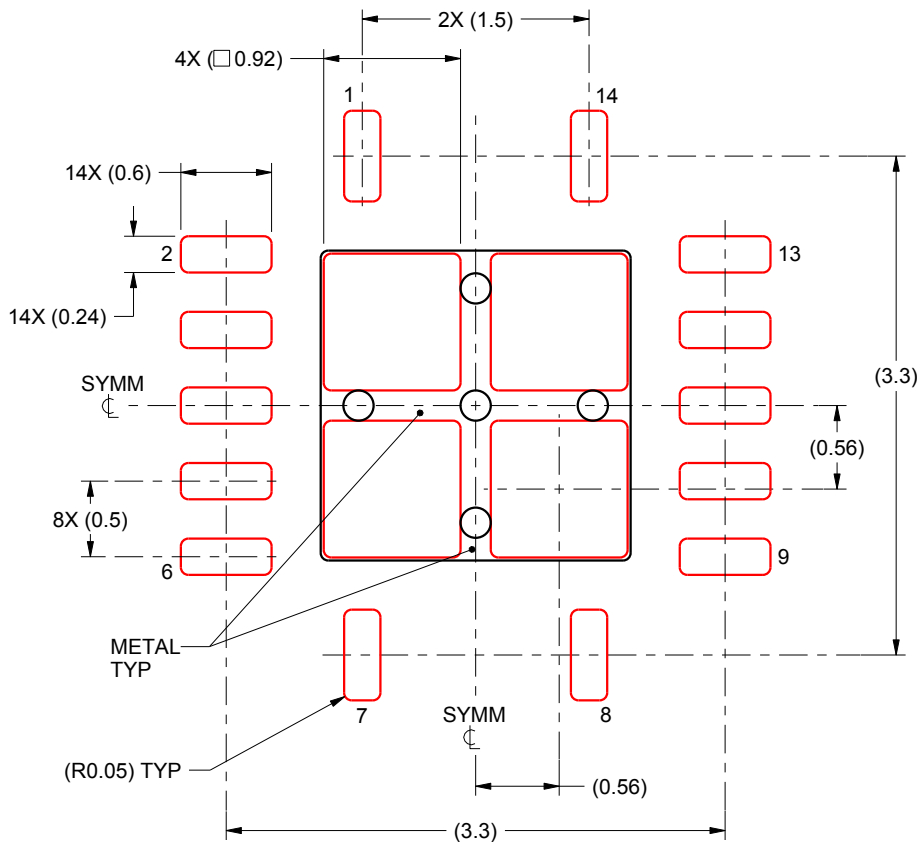

SOLDER PASTE EXAMPLE
BASED ON 0.125 mm THICK STENCIL

EXPOSED PAD
80% PRINTED SOLDER COVERAGE BY AREA
SCALE:20X

4221612/B 02/2015

NOTES: (continued)

5. Laser cutting apertures with trapezoidal walls and rounded corners may offer better paste release. IPC-7525 may have alternate design recommendations.

IMPORTANT NOTICE AND DISCLAIMER

TI PROVIDES TECHNICAL AND RELIABILITY DATA (INCLUDING DATASHEETS), DESIGN RESOURCES (INCLUDING REFERENCE DESIGNS), APPLICATION OR OTHER DESIGN ADVICE, WEB TOOLS, SAFETY INFORMATION, AND OTHER RESOURCES "AS IS" AND WITH ALL FAULTS, AND DISCLAIMS ALL WARRANTIES, EXPRESS AND IMPLIED, INCLUDING WITHOUT LIMITATION ANY IMPLIED WARRANTIES OF MERCHANTABILITY, FITNESS FOR A PARTICULAR PURPOSE OR NON-INFRINGEMENT OF THIRD PARTY INTELLECTUAL PROPERTY RIGHTS.

These resources are intended for skilled developers designing with TI products. You are solely responsible for (1) selecting the appropriate TI products for your application, (2) designing, validating and testing your application, and (3) ensuring your application meets applicable standards, and any other safety, security, regulatory or other requirements.

These resources are subject to change without notice. TI grants you permission to use these resources only for development of an application that uses the TI products described in the resource. Other reproduction and display of these resources is prohibited. No license is granted to any other TI intellectual property right or to any third party intellectual property right. TI disclaims responsibility for, and you fully indemnify TI and its representatives against any claims, damages, costs, losses, and liabilities arising out of your use of these resources.

TI's products are provided subject to [TI's Terms of Sale](#), [TI's General Quality Guidelines](#), or other applicable terms available either on ti.com or provided in conjunction with such TI products. TI's provision of these resources does not expand or otherwise alter TI's applicable warranties or warranty disclaimers for TI products. Unless TI explicitly designates a product as custom or customer-specified, TI products are standard, catalog, general purpose devices.

TI objects to and rejects any additional or different terms you may propose.

Copyright © 2026, Texas Instruments Incorporated

Last updated 10/2025