

LM140QML Three Terminal Positive Regulators

Check for Samples: [LM140QML](#)

FEATURES

- Complete Specifications at 1.0A and 0.5A Loads
- No External Components
- Internal Thermal Overload Protection
- Internal Short Circuit Current-Limiting
- Output Transistor Safe-Area Compensation

DESCRIPTION

The monolithic 3-terminal positive voltage regulators employ internal current-limiting, thermal shutdown and safe-area compensation, making them essentially indestructible. If adequate heat sinking is provided, they can deliver over 0.5A output current. They are intended as fixed voltage regulators in a wide range of applications including local (on-card) regulation for elimination of noise and distribution problems associated with single-point regulation. In addition to use as fixed voltage regulators, these devices can be used with external components to obtain adjustable output voltages and currents.

Considerable effort was expended to make the entire series of regulators easy to use and minimize the number of external components. It is not necessary to bypass the output, although this does improve transient response. Input bypassing is needed only if the regulator is located far from the filter capacitor of the power supply.

Connection Diagram

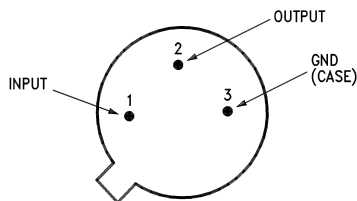

**Figure 1. Steel Metal Can TO-39 Package (NDT)
Bottom View
See Package Number NDT0003A**

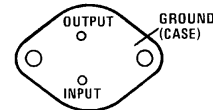

**Figure 2. TO-3 Metal Can (K)
Bottom View
See Package Number K0002C**



These devices have limited built-in ESD protection. The leads should be shorted together or the device placed in conductive foam during storage or handling to prevent electrostatic damage to the MOS gates.



Please be aware that an important notice concerning availability, standard warranty, and use in critical applications of Texas Instruments semiconductor products and disclaimers thereto appears at the end of this data sheet.

All trademarks are the property of their respective owners.

Absolute Maximum Ratings⁽¹⁾

DC Input Voltage		35V	
Internal Power Dissipation ⁽²⁾		Internally Limited	
Maximum Junction Temperature (T _{Jmax})		150°C	
Storage Temperature Range		-65°C ≤ T _A ≤ +150°C	
Operating Temperature Range		-55°C ≤ T _A ≤ +125°C	
Lead Temperature (Soldering 10 seconds)		300°C	
Thermal Resistance	θ _{JA}	T0-39 (Still Air)	232°C/W
		T0-39 (500 LF/Min Air Flow)	77°C/W
		T0-3 (Still Air)	35°C/W
		T0-3 (500 LF/Min Air Flow)	TBD
	θ _{JC}	T0-39	15°C/W
		T0-3	4°C/W
ESD Susceptibility ⁽³⁾		2KV	

- (1) Absolute Maximum Ratings indicate limits beyond which damage to the device may occur. Operating Ratings indicate conditions for which the device is functional, but do not specify specific performance limits. For ensured specifications and test conditions, see the Electrical Characteristics. The ensured specifications apply only for the test conditions listed. Some performance characteristics may degrade when the device is not operated under the listed test conditions.
- (2) The maximum power dissipation must be derated at elevated temperatures and is dictated by T_{Jmax} (maximum junction temperature), θ_{JA} (package junction to ambient thermal resistance), and T_A (ambient temperature). The maximum allowable power dissipation at any temperature is P_{Dmax} = (T_{Jmax} - T_A)/θ_{JA} or the number given in the Absolute Maximum Ratings, whichever is lower.
- (3) Human body model, 100pF discharged through 1.5KΩ

Quality Conformance Inspection

MIL-Std-883, Method 5005 - Group A

Subgroup	Description	Temp °C
1	Static tests at	+25
2	Static tests at	+125
3	Static tests at	-55
4	Dynamic tests at	+25
5	Dynamic tests at	+125
6	Dynamic tests at	-55
7	Functional tests at	+25
8A	Functional tests at	+125
8B	Functional tests at	-55
9	Switching tests at	+25
10	Switching tests at	+125
11	Switching tests at	-55
12	Settling time at	+25
13	Settling time at	+125
14	Settling time at	-55

LM140H–5.0 Electrical Characteristics DC Parameters

The following conditions apply, unless otherwise specified.

DC: $V_I = 10V$, $I_L = 350mA$

Symbol	Parameter	Conditions	Notes	Min	Max	Unit	Sub-groups
V_O	Output Voltage	$V_I = 35V$, $I_L = 5mA$		4.75	5.75	V	1
				4.80	5.20	V	1
		$V_I = 8V$		4.70	5.30	V	1, 2, 3
		$V_I = 8V$, $I_L = 5mA$		4.70	5.30	V	1, 2, 3
		$V_I = 20V$, $I_L = 5mA$		4.70	5.30	V	1, 2, 3
		$V_I = 20V$		4.70	5.30	V	1, 2, 3
R_{Line}	Line Regulation	$7V \leq V_I \leq 25V$, $I_L = 200mA$		-50	50	mV	1
		$8V \leq V_I \leq 25V$, $I_L = 200mA$		-50	50	mV	2, 3
		$8V \leq V_I \leq 20V$, $I_L = 200mA$		-25	25	mV	1
				-40	40	mV	2, 3
R_{Load}	Load Regulation	$5mA \leq I_L \leq 500mA$		-50	50	mV	1
				-100	100	mV	2, 3
		$5mA \leq I_L \leq 200mA$		-25	25	mV	1
				-50	50	mV	2, 3
I_Q	Quiescent Current			7.0	mA	1, 2, 3	
ΔI_Q	Quiescent Current Change	$8V \leq V_I \leq 25V$, $I_L = 200mA$		-0.8	0.8	mA	1, 2, 3
		$5mA \leq I_L \leq 350mA$		-0.5	0.5	mA	1, 2, 3
I_{PK}	Peak Current	$V_I - V_O = 7V$	See ⁽¹⁾	0.4	2.0	A	1, 2, 3
V_{DO}	Dropout Voltage		See ⁽²⁾		2.5	V	1
I_{OS}	Short Circuit Current	$V_I = 35V$			1.0	A	1, 2, 3

(1) V_O is set to 90% V_{Ref}

(2) $V_{DO} = V_I - V_O$ when V_O is 95% of V_{Ref} .

LM140H–5.0 Electrical Characteristics AC Parameters

The following conditions apply, unless otherwise specified.

AC: $V_I = 10V$, $I_L = 350mA$

Symbol	Parameter	Conditions	Notes	Min	Max	Unit	Sub-groups
RR	Ripple Rejection	$I_L = 125mA$, $e_i = 1V_{RMS}$, $f = 2.4KHz$, $V_I = 10V$		62		dB	4, 5, 6

LM140H–12 Electrical Characteristics DC Parameters

The following conditions apply, unless otherwise specified.

DC: $V_I = 19V$, $I_L = 350mA$

Symbol	Parameter	Conditions	Notes	Min	Max	Unit	Sub-groups
V_O	Output Voltage	$V_I = 35V$, $I_L = 5mA$		11.4	12.6	V	1
				11.5	12.5	V	1
		$V_I = 15.5V$		11.4	12.6	V	1, 2, 3
		$V_I = 15.5V$, $I_L = 5mA$		11.4	12.6	V	1, 2, 3
		$V_I = 27V$, $I_L = 5mA$		11.4	12.6	V	1, 2, 3
		$V_I = 27V$		11.4	12.6	V	1, 2, 3
R_{Line}	Line Regulation	$14.5V \leq V_I \leq 30V$, $I_L = 200mA$		-60	60	mV	1
		$15.0V \leq V_I \leq 30V$, $I_L = 200mA$		-120	120	mV	2, 3
		$16V \leq V_I \leq 25V$, $I_L = 200mA$		-30	30	mV	1
				-60	60	mV	2, 3
R_{Load}	Load Regulation	$5mA \leq I_L \leq 500mA$		-120	120	mV	1
				-240	240	mV	2, 3
		$5mA \leq I_L \leq 200mA$		-60	60	mV	1
				-120	120	mV	2, 3
I_Q	Quiescent Current			7.0	mA	1, 2, 3	
ΔI_Q	Quiescent Current Change	$14.5V \leq V_I \leq 30V$, $I_L = 200mA$		-0.8	0.8	mA	1, 2, 3
		$5mA \leq I_L \leq 350mA$		-0.5	0.5	mA	1, 2, 3
I_{PK}	Peak Current	$V_I - V_O = 7V$	See ⁽¹⁾	0.4	2.0	A	1, 2, 3
V_{DO}	Dropout Voltage		See ⁽²⁾		2.5	V	1
I_{OS}	Short Circuit Current	$V_I = 35V$			1.0	A	1, 2, 3

(1) V_O is set to 90% V_{Ref}

(2) $V_{DO} = V_I - V_O$ when V_O is 95% of V_{Ref} .

LM140H–12 Electrical Characteristics AC Parameters

Symbol	Parameter	Conditions	Notes	Min	Max	Unit	Sub-groups
RR	Ripple Rejection	$V_I = 17V$, $I_L = 125mA$, $e_i = 1V_{RMS}$, $f = 2.4KHz$		55		dB	4, 5, 6

LM140H–15 Electrical Characteristics DC Parameters

The following conditions apply, unless otherwise specified.

DC: $V_I = 23V$, $I_L = 350mA$

Symbol	Parameter	Conditions	Notes	Min	Max	Unit	Sub-groups
V_O	Output Voltage	$V_I = 35V$, $I_L = 5mA$		14.25	15.75	V	1
				14.40	15.60	V	1
		$V_I = 18.5V$		14.25	15.75	V	1, 2, 3
		$V_I = 18.5V$, $I_L = 5mA$		14.25	15.75	V	1, 2, 3
		$V_I = 30V$, $I_L = 5mA$		14.25	15.75	V	1, 2, 3
		$V_I = 30V$		14.25	15.75	V	1, 2, 3
R_{Line}	Line Regulation	$17.5V \leq V_I \leq 30V$, $I_L = 200mA$		-60	60	mV	1
		$18.5V \leq V_I \leq 30V$, $I_L = 200mA$		-120	120	mV	2, 3
		$20V \leq V_I \leq 30V$, $I_L = 200mA$		-30	30	mV	1
				-60	60	mV	2, 3
R_{Load}	Load Regulation	$5mA \leq I_L \leq 500mA$		-150	150	mV	1
				-300	300	mV	2, 3
		$5mA \leq I_L \leq 200mA$		-75	75	mV	1
				-150	150	mV	2, 3
I_Q	Quiescent Current			7.0	mA	1, 2, 3	
ΔI_Q	Quiescent Current Change	$17.5V \leq V_I \leq 30V$, $I_L = 200mA$		-0.8	0.8	mA	1, 2, 3
		$5mA \leq I_L \leq 350mA$		-0.5	0.5	mA	1, 2, 3
I_{PK}	Peak Current	$V_I - V_O = 7V$	See ⁽¹⁾	0.4	2.0	A	1, 2, 3
V_{DO}	Dropout Voltage		See ⁽²⁾		2.5	V	1
I_{OS}	Short Circuit Current	$V_I = 35V$			1.0	A	1, 2, 3

(1) V_O is set to 90% V_{Ref}

(2) $V_{DO} = V_I - V_O$ when V_O is 95% of V_{Ref} .

LM140H–15 Electrical Characteristics AC Parameters

The following conditions apply, unless otherwise specified.

AC: $V_I = 23V$, $I_L = 350mA$

Symbol	Parameter	Conditions	Notes	Min	Max	Unit	Sub-groups
RR	Ripple Rejection	$V_I = 20V$, $I_L = 125mA$, $e_I = 1V_{RMS}$, $f = 2.4KHz$		54		dB	4, 5, 6

LM140K–5.0 Electrical Characteristics DC Parameters

The following conditions apply, unless otherwise specified.

DC: $V_I = 10V$, $I_L = 5mA$

Symbol	Parameter	Conditions	Notes	Min	Max	Unit	Sub-groups
I_Q	Quiescent Current	$I_L = 1A$			6.0	mA	1
					7.0	mA	2, 3
ΔQ	Quiescent Current Change	$I_L = 1A, 8V \leq V_I \leq 20mA$		-0.8	0.8	mA	1
		$I_L \leq 500mA, 8V \leq V_I \leq 25V$		-0.8	0.8	mA	1, 2, 3
		$5mA, \leq I_L \leq 1.0A$		-0.5	0.5	mA	1, 2, 3
V_O	Output Voltage			4.80	5.20	V	1
		$V_I = 8V$		4.75	5.25	V	1, 2, 3
		$V_I = 8V, I_L = 1A$		4.75	5.25	V	1, 2, 3
		$V_I = 20V$		4.75	5.25	V	1, 2, 3
		$V_I = 20V, I_L = 1A$		4.75	5.25	V	1, 2, 3
R_{Line}	Line Regulation	$I_L = 500mA, 7V \leq V_I \leq 25V$		-50	50	mV	1, 2, 3
		$I_L = 1A, 7.3V \leq V_I \leq 20V$		-50	50	mV	1
		$I_L = 1A, 8.0V \leq V_I \leq 20V$		-50	50	mV	2, 3
		$I_L = 1A, 8V \leq V_I \leq 12V$		-25	25	mV	1, 2, 3
R_{Load}	Load Regulation	$5mA \leq I_L \leq 1.5A$		-50	50	mV	1
		$5mA \leq I_L \leq 1.0A$		-50	50	mV	2, 3
		$250mA \leq I_L \leq 750mA$		-25	25	mV	1
I_{OS}	Current Limit			-4.0	-0.02	A	1
		$V_I = 35V$		-2.0	-0.02	A	1

LM140K–5.0 Electrical Characteristics AC Parameters

The following conditions apply, unless otherwise specified.

AC: $V_I = 10V$, $I_L = 5mA$

Symbol	Parameter	Conditions	Notes	Min	Max	Unit	Sub-groups
RR	Ripple Rejection	$f = 120Hz, I_L = 350mA,$ $e_i = 1V_{RMS}$		68		dB	4

LM140K–12 Electrical Characteristics DC Parameters

The following conditions apply, unless otherwise specified.

DC: $V_I = 19V$, $I_L = 5mA$

Symbol	Parameter	Conditions	Notes	Min	Max	Unit	Sub-groups
I_Q	Quiescent Current	$I_L = 1A$			6.0	mA	1
					7.0	mA	2, 3
ΔI_Q	Quiescent Current Change	$I_L = 1A$, $15.5V \leq V_I \leq 27V$		-0.8	0.8	mA	1
		$I_L = 500mA$, $15V \leq V_I \leq 30V$		-0.8	0.8	mA	1, 2, 3
		$5mA \leq I_L \leq 1A$		-0.5	0.5	mA	1, 2, 3
V_O	Output Voltage			11.5	12.5	V	1
		$V_I = 15.5V$		11.4	12.6	V	1, 2, 3
		$V_I = 15.5V$, $I_L = 1A$		11.4	12.6	V	1, 2, 3
		$V_I = 27V$		11.4	12.6	V	1, 2, 3
		$V_I = 27V$, $I_L = 1A$		11.4	12.6	V	1, 2, 3
R_{Line}	Line Regulation	$I_L = 500mA$, $14.5V \leq V_I \leq 25V$		-120	120	mV	1, 2, 3
		$I_L = 1A$, $14.6V \leq V_I \leq 27V$		-120	120	mV	1
		$I_L = 1A$, $15.0V \leq V_I \leq 27V$		-120	120	mV	2, 3
		$I_L = 1A$, $16V \leq V_I \leq 22V$		-60	60	mV	1, 2, 3
R_{Load}	Load Regulation	$5mA \leq I_L \leq 1.5A$		-120	120	mV	1
		$5mA \leq I_L \leq 1.0A$		-120	120	mV	2, 3
		$250mA \leq I_L \leq 750mA$		-60	60	mV	1
I_{OS}	Current Limit	$V_I = 17V$		-3.5	-0.02	A	1
		$V_I = 35V$		-2.0	-0.02	A	1

LM140K–12 Electrical Characteristics AC Parameters

The following conditions apply, unless otherwise specified.

AC: $V_I = 19V$, $I_L = 5mA$

Symbol	Parameter	Conditions	Notes	Min	Max	Unit	Sub-groups
RR	Ripple Rejection	$f = 120Hz$, $I_L = 350mA$, $e_i = 1V_{RMS}$		61		dB	4

LM140K–15 Electrical Characteristics DC Parameters

The following conditions apply, unless otherwise specified.

DC: $V_I = 23V$, $I_L = 5mA$

Symbol	Parameter	Conditions	Notes	Min	Max	Unit	Sub-groups
I_Q	Quiescent Current	$I_L = 1A$			6.0	mA	1
					7.0	mA	2, 3
ΔI_Q	Quiescent Current Change	$I_L = 1A, 18.5V \leq V_I \leq 30V$		-0.8	0.8	mA	1
		$I_L = 500mA, 18.5V \leq V_I \leq 30V$		-0.8	0.8	mA	2, 3
		$5mA \leq I_L \leq 1A$		-0.5	0.5	mA	1, 2, 3
V_O	Output Voltage			14.4	15.6	V	1
		$V_I = 18.5V$		14.25	15.75	V	1, 2, 3
		$V_I = 18.5V, I_L = 1A$		14.25	15.75	V	1, 2, 3
		$V_I = 30V$		14.25	15.75	V	1, 2, 3
		$V_I = 30V, I_L = 1A$		14.25	15.75	V	1, 2, 3
R_{Line}	Line Regulation	$I_L = 500mA, 17.5V \leq V_I \leq 30V$		-150	150	mV	1
		$I_L = 500mA, 18.5V \leq V_I \leq 30V$		-150	150	mV	2, 3
		$I_L = 1A, 17.7V \leq V_I \leq 30V$		-75	75	mV	1
		$I_L = 1A, 20V \leq V_I \leq 26V$		-75	75	mV	1, 2, 3
R_{Load}	Load Regulation	$5mA \leq I_L \leq 1.5A$		-150	150	mV	1
		$5mA \leq I_L \leq 1.0A$		-150	150	mV	2, 3
		$250mA \leq I_L \leq 750mA$		-75	75	mV	1
I_{OS}	Current Limit	$V_I = 20V$		-3.5	-0.02	A	1
		$V_I = 35V$		-2.0	-0.02	A	1

LM140K–15 Electrical Characteristics AC Parameters

The following conditions apply, unless otherwise specified.

AC: $V_I = 23V$, $I_L = 5mA$

Symbol	Parameter	Conditions	Notes	Min	Max	Unit	Sub-groups
RR	Ripple Rejection	$f = 120Hz, I_L = 350mA,$ $e_i = 1V_{RMS}$		60		dB	4

REVISION HISTORY SECTION

Released	Revision	Section	Originator	Changes
02/21/06	A	New Release, Corporate format	L. Lytle	6 MDS data sheets converted into one Corp. data sheet format. The drift tables were eliminated from the 883 section since it did not apply. MDS data sheets MNLM140-05H Rev 0B0, MNLM140-05-K Rev. 0C0, MNLM140-12H Rev 0A0, MNLM140-12K Rev 0B0, MNLM140-15H Rev 0A0, and MNLM140-15K Rev 0B0 will be archived.
05/02/13	B			Changed layout of National Data Sheet to TI format.

PACKAGING INFORMATION

Orderable part number	Status (1)	Material type (2)	Package Pins	Package qty Carrier	RoHS (3)	Lead finish/ Ball material (4)	MSL rating/ Peak reflow (5)	Op temp (°C)	Part marking (6)
LM140H-12/883	Active	Production	TO (NDT) 3	20 JEDEC TRAY (5+1)	No	Call TI	Level-1-NA-UNLIM	-55 to 125	LM140H-12/883 Q AC O LM140H-12/883 Q >T
LM140H-15/883	Active	Production	TO (NDT) 3	20 JEDEC TRAY (5+1)	No	Call TI	Level-1-NA-UNLIM	-55 to 125	LM140H-15/883 Q AC O LM140H-15/883 Q >T
LM140H-5.0/883	Active	Production	TO (NDT) 3	20 JEDEC TRAY (5+1)	No	Call TI	Level-1-NA-UNLIM	-55 to 125	LM140H-5.0/883 Q A CO LM140H-5.0/883 Q > T
LM140K-12/883	Active	Production	TO (K) 2	50 TRAY NON-STD	Yes	Call TI	Level-1-NA-UNLIM	-55 to 125	(LM120H-15P+, LM14 0K-12) /883 Q ACO /883 Q >T
LM140KG-12 MD8	Active	Production	DIESALE (Y) 0	221 JEDEC TRAY (5+1)	Yes	Call TI	Level-1-NA-UNLIM	-55 to 125	
LM140KG-5 MD8	Active	Production	DIESALE (Y) 0	221 JEDEC TRAY (5+1)	Yes	Call TI	Level-1-NA-UNLIM	-55 to 125	

(1) **Status:** For more details on status, see our [product life cycle](#).

(2) **Material type:** When designated, preproduction parts are prototypes/experimental devices, and are not yet approved or released for full production. Testing and final process, including without limitation quality assurance, reliability performance testing, and/or process qualification, may not yet be complete, and this item is subject to further changes or possible discontinuation. If available for ordering, purchases will be subject to an additional waiver at checkout, and are intended for early internal evaluation purposes only. These items are sold without warranties of any kind.

(3) **RoHS values:** Yes, No, RoHS Exempt. See the [TI RoHS Statement](#) for additional information and value definition.

(4) **Lead finish/Ball material:** Parts may have multiple material finish options. Finish options are separated by a vertical ruled line. Lead finish/Ball material values may wrap to two lines if the finish value exceeds the maximum column width.

(5) **MSL rating/Peak reflow:** The moisture sensitivity level ratings and peak solder (reflow) temperatures. In the event that a part has multiple moisture sensitivity ratings, only the lowest level per JEDEC standards is shown. Refer to the shipping label for the actual reflow temperature that will be used to mount the part to the printed circuit board.

(6) **Part marking:** There may be an additional marking, which relates to the logo, the lot trace code information, or the environmental category of the part.

Multiple part markings will be inside parentheses. Only one part marking contained in parentheses and separated by a "-" will appear on a part. If a line is indented then it is a continuation of the previous line and the two combined represent the entire part marking for that device.

Important Information and Disclaimer: The information provided on this page represents TI's knowledge and belief as of the date that it is provided. TI bases its knowledge and belief on information provided by third parties, and makes no representation or warranty as to the accuracy of such information. Efforts are underway to better integrate information from third parties. TI has taken and continues to take reasonable steps to provide representative and accurate information but may not have conducted destructive testing or chemical analysis on incoming materials and chemicals. TI and TI suppliers consider certain information to be proprietary, and thus CAS numbers and other limited information may not be available for release.

In no event shall TI's liability arising out of such information exceed the total purchase price of the TI part(s) at issue in this document sold by TI to Customer on an annual basis.

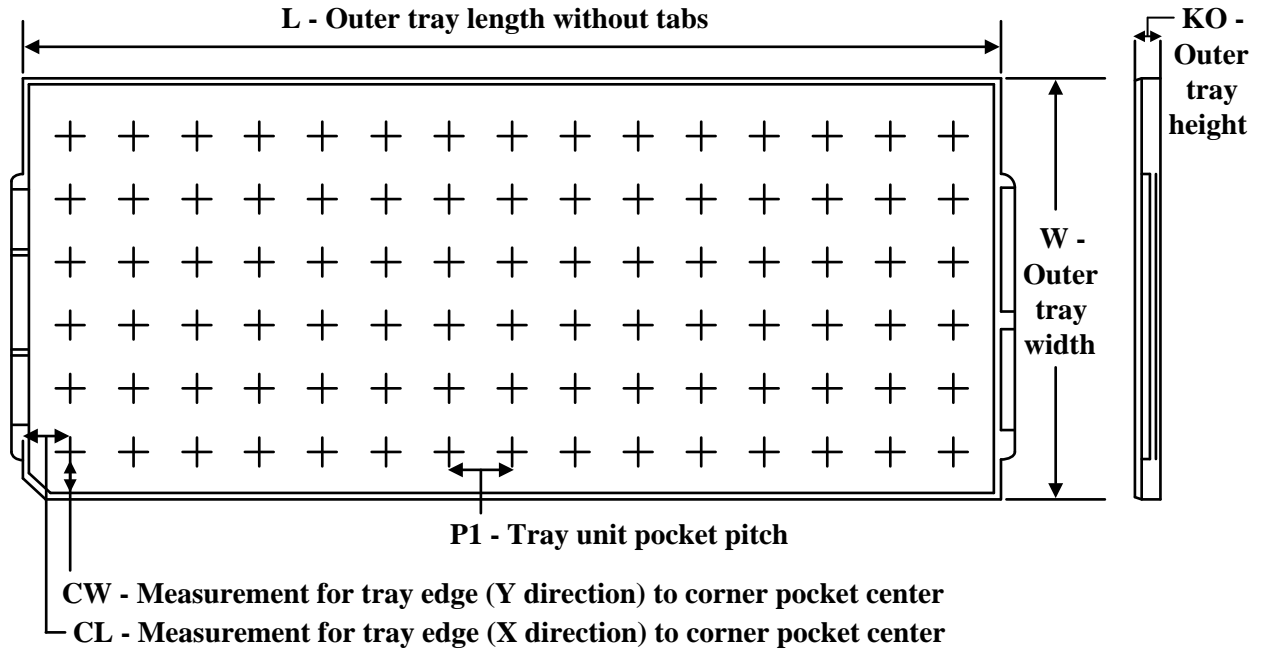
TRAY

Chamfer on Tray corner indicates Pin 1 orientation of packed units.

*All dimensions are nominal

Device	Package Name	Package Type	Pins	SPQ	Unit array matrix	Max temperature (°C)	L (mm)	W (mm)	K0 (µm)	P1 (mm)	CL (mm)	CW (mm)
LM140H-12/883	NDT	TO-CAN	3	20	2 X 10	150	126.49	61.98	8890	11.18	12.95	18.54
LM140H-15/883	NDT	TO-CAN	3	20	2 X 10	150	126.49	61.98	8890	11.18	12.95	18.54
LM140H-5.0/883	NDT	TO-CAN	3	20	2 X 10	150	126.49	61.98	8890	11.18	12.95	18.54
LM140K-12/883	K	TO-CAN	2	50	9 X 6	NA	292.1	215.9	25654	3.87	22.3	25.4

NDT0003A

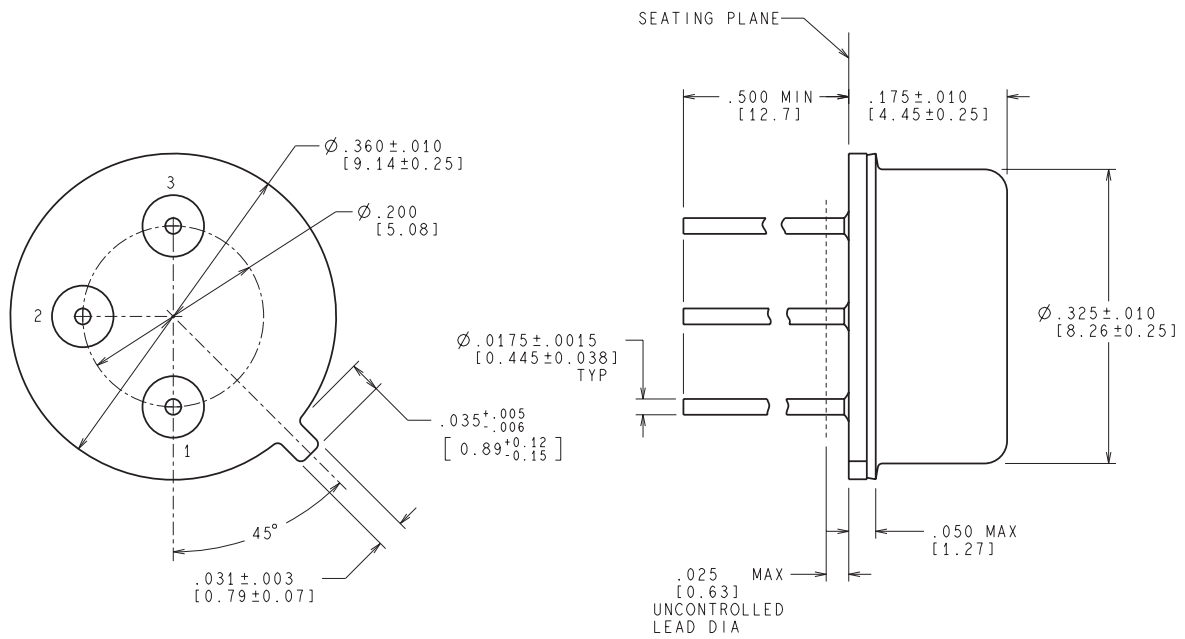

CONTROLLING DIMENSION IS INCH
VALUES IN [] ARE MILLIMETERS

MIL-PRF-38535
CONFIGURATION CONTROL

H03A (Rev D)

K0002A



PACKAGE OUTLINE

TO-CAN - 7.747 mm max height

TRANSISTOR OUTLINE

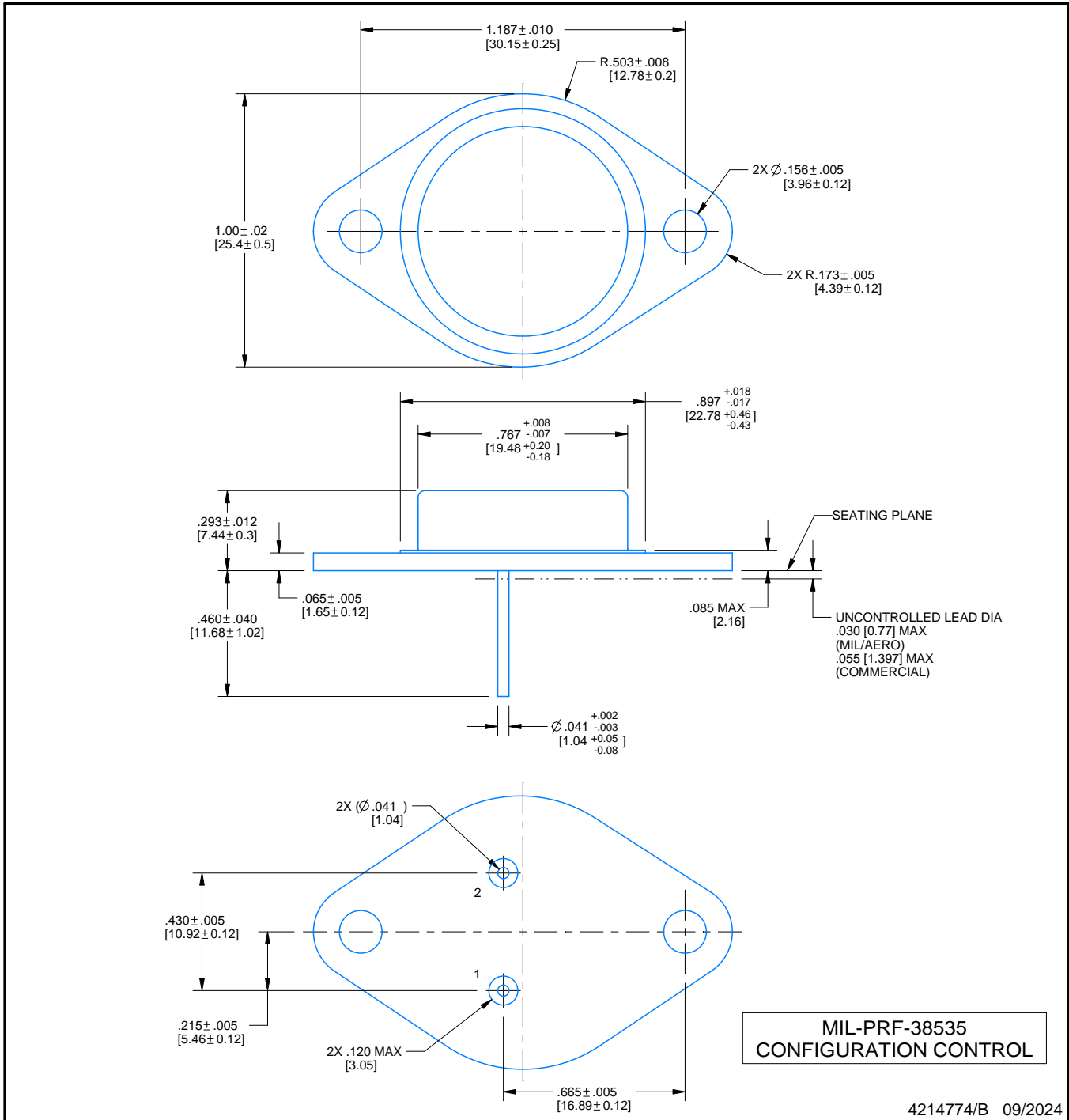

NOTES:

1. Linear dimensions are in inches [millimeters]. Dimensions in parenthesis are for reference only. Controlling dimensions are in inches. Dimensioning and tolerancing per ASME Y14.5M.
2. This drawing is subject to change without notice.
3. Leads not to be bent greater than 15°.

IMPORTANT NOTICE AND DISCLAIMER

TI PROVIDES TECHNICAL AND RELIABILITY DATA (INCLUDING DATASHEETS), DESIGN RESOURCES (INCLUDING REFERENCE DESIGNS), APPLICATION OR OTHER DESIGN ADVICE, WEB TOOLS, SAFETY INFORMATION, AND OTHER RESOURCES "AS IS" AND WITH ALL FAULTS, AND DISCLAIMS ALL WARRANTIES, EXPRESS AND IMPLIED, INCLUDING WITHOUT LIMITATION ANY IMPLIED WARRANTIES OF MERCHANTABILITY, FITNESS FOR A PARTICULAR PURPOSE OR NON-INFRINGEMENT OF THIRD PARTY INTELLECTUAL PROPERTY RIGHTS.

These resources are intended for skilled developers designing with TI products. You are solely responsible for (1) selecting the appropriate TI products for your application, (2) designing, validating and testing your application, and (3) ensuring your application meets applicable standards, and any other safety, security, regulatory or other requirements.

These resources are subject to change without notice. TI grants you permission to use these resources only for development of an application that uses the TI products described in the resource. Other reproduction and display of these resources is prohibited. No license is granted to any other TI intellectual property right or to any third party intellectual property right. TI disclaims responsibility for, and you fully indemnify TI and its representatives against any claims, damages, costs, losses, and liabilities arising out of your use of these resources.

TI's products are provided subject to [TI's Terms of Sale](#), [TI's General Quality Guidelines](#), or other applicable terms available either on [ti.com](#) or provided in conjunction with such TI products. TI's provision of these resources does not expand or otherwise alter TI's applicable warranties or warranty disclaimers for TI products. Unless TI explicitly designates a product as custom or customer-specified, TI products are standard, catalog, general purpose devices.

TI objects to and rejects any additional or different terms you may propose.

Copyright © 2026, Texas Instruments Incorporated

Last updated 10/2025