

LM25007 42V, 0.5A Step-Down Switching Regulator

Check for Samples: [LM25007](#)

FEATURES

- **Integrated 0.74Ω N-Channel MOSFET Switch**
- **Guaranteed 0.5A Output Current**
- **Ultra-Fast Transient Response**
- **Up to 800kHz Operation**
- **No Control Loop Compensation Required**
- **Vin Feed Forward Provides Constant Operating Frequency**
- **2% Accurate 2.5V Feedback from -40°C to 125°C**
- **Highly Efficient Operation**
- **Intelligent Current Limit Protection**
- **External Shutdown Control**
- **Thermal Shutdown**
- **VSSOP and Thermally Enhanced WSON Packages**

TYPICAL APPLICATIONS

- **12VDC and 24VDC Distributed Rail Systems**
- **24VAC Systems**
- **Automotive Body Electronics and Telematics**
- **Industrial Systems**
- **HB-LED Constant Current Source**
- **Package:**
 - **VSSOP-8**
 - **WSON-8 (4mm x 4mm)**

DESCRIPTION

The LM25007 is a monolithic step-down switching regulator featuring all of the functions needed to implement a low cost, efficient, power supply. Capable of driving a 0.5A load over a 9V-42V input voltage range, this device is easy to apply and is provided in the small VSSOP-8 and the thermally enhanced WSON-8 packages. Ultra-fast transient response is achieved through the use of a constant on-time architecture with Vin feed forward. This feature provides an almost constant operating frequency over load and input voltage variations. The operating frequency can be adjusted with a single resistor. This architecture is easy to use and tolerant of component selection. An intelligent current limit is implemented in the LM25007 with forced off time that is inversely proportional to Vout thus ensuring recovery from fault conditions. The output voltage may be set from 2.5V to >30V. To improve efficiency in light load applications, the Vcc pin can be connected to an external voltage source to eliminate the drop through the internal regulator. Additional features include: thermal shutdown, Vcc under-voltage lockout, gate drive under-voltage lockout, and max duty cycle limiter.



Please be aware that an important notice concerning availability, standard warranty, and use in critical applications of Texas Instruments semiconductor products and disclaimers thereto appears at the end of this data sheet.

All trademarks are the property of their respective owners.

Basic Step-Down Regulator

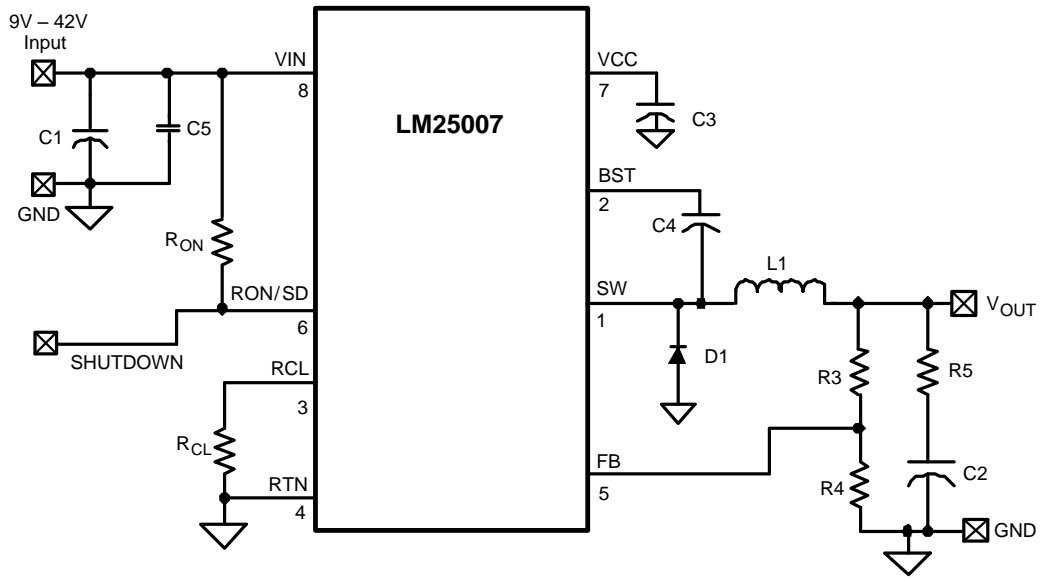

Connection Diagram

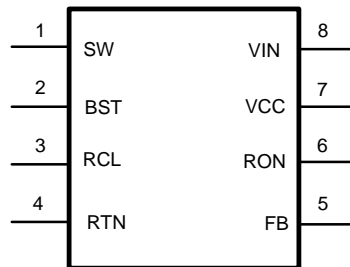

8-Lead VSSOP, WSON

Pin Descriptions

Pin	Name	Description	Application Information
1	SW	Switching Node	Power switching node. Connect to the inductor, bootstrap capacitor, and free-wheeling diode.
2	BST	Boost Boot-strap capacitor input	An external capacitor is required between the BST and the SW pins. A 0.01µF ceramic capacitor is recommended.
3	RCL	Current Limit OFF time programming pin	A resistor between this pin and RTN sets the off-time when current limit is detected. The off-time is preset to 17 µs if FB = 0V .
4	RTN	Circuit Ground	
5	FB	Feedback Signal from Regulated Output	This pin is connected to the inverting input of the internal regulation comparator. The regulation threshold is 2.5V.
6	RON/SD	On-time set pin	A resistor between this pin and VIN sets the switch on-time as a function of Vin. The minimum recommended on-time is 300ns at the maximum input voltage.
7	VCC	Output from the internal high voltage bias regulator.	If an auxiliary voltage is available to raise the voltage on this pin above the regulation setpoint (7V), the internal series pass regulator will shutdown, reducing the IC power dissipation. Do not exceed 14V. This output provides gate drive power for the internal Buck switch. An internal diode is provided between this pin and the BST pin. A local 0.1µF decoupling capacitor is recommended.
8	VIN	Input supply voltage	Recommended operating range: 9V to 42V.
-	EP	Exposed pad, underside of the WSON package option	Exposed metal pad on the WSON package underside. It is recommended to connect this pad to the PC board ground plane to aid in heat dissipation.

Typical Application Circuit and Block Diagram

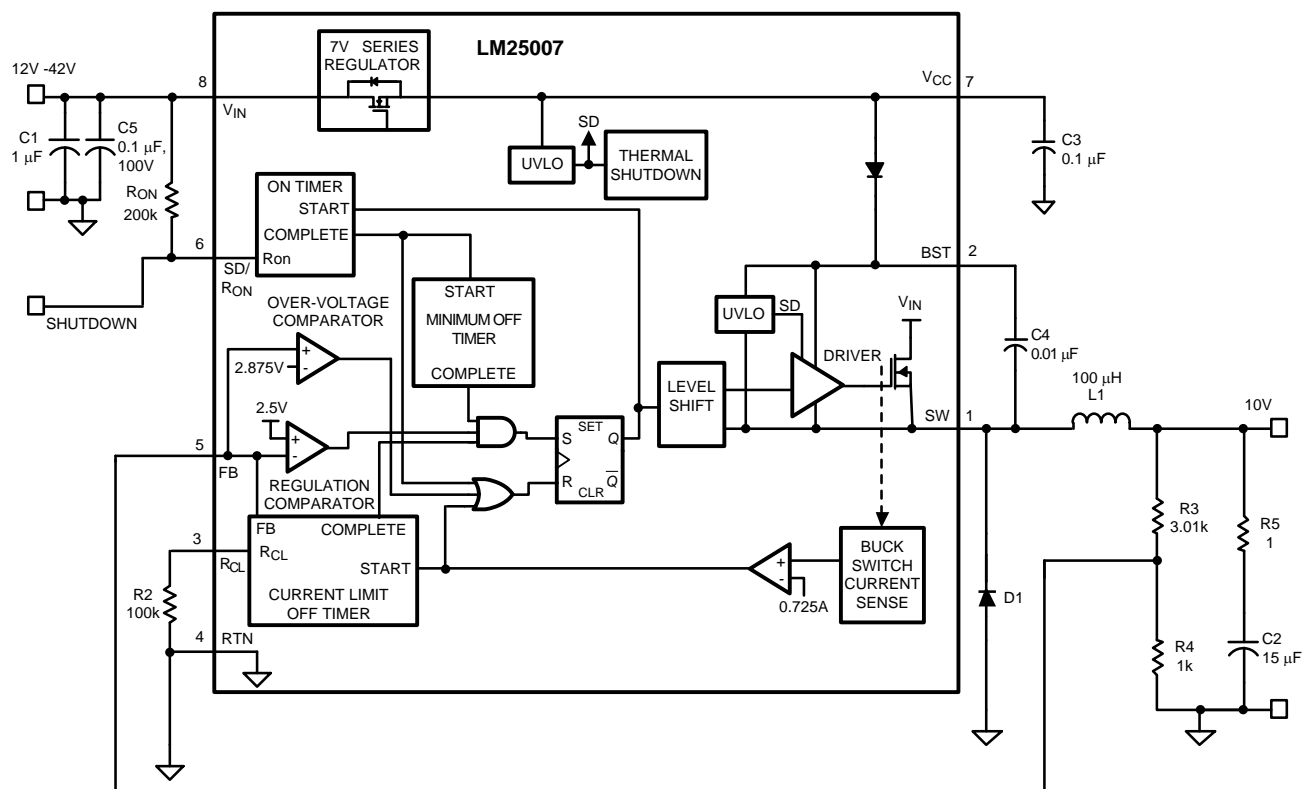



These devices have limited built-in ESD protection. The leads should be shorted together or the device placed in conductive foam during storage or handling to prevent electrostatic damage to the MOS gates.

Absolute Maximum Ratings⁽¹⁾

V _{IN} to RTN	45V
BST to RTN	59V
SW to RTN (Steady State)	-1V
ESD Rating, Human Body Model ⁽²⁾	2kV
BST to V _{CC}	45V
BST to SW	14V
V _{CC} to RTN	14V
All Other Inputs to RTN	-0.3 to 7V
Storage Temperature Range	-65°C to +150°C

- (1) [Absolute Maximum Ratings](#) are limits beyond which damage to the device may occur. [Operating Ratings](#) are conditions under which operation of the device is intended to be functional. For guaranteed specifications and test conditions, see the [Electrical Characteristics](#).
- (2) The human body model is a 100pF capacitor discharge through a 1.5kΩ resistor into each pin. The human body ESD compliance level for Pin 7 and 8 is 1000V.

Operating Ratings⁽¹⁾

V _{IN}	9V to 42V
Junction Temperature	-40°C to + 125°C

- (1) [Absolute Maximum Ratings](#) are limits beyond which damage to the device may occur. [Operating Ratings](#) are conditions under which operation of the device is intended to be functional. For guaranteed specifications and test conditions, see the [Electrical Characteristics](#).

Electrical Characteristics⁽¹⁾

Specifications with standard type are for $T_J = 25^\circ\text{C}$ only; limits in boldface type apply over the full Operating Junction Temperature (T_J) range. Minimum and Maximum limits are guaranteed through test, design, or statistical correlation. Typical values represent the most likely parametric norm at $T_J = 25^\circ\text{C}$, and are provided for reference purposes only. Unless otherwise stated the following conditions apply: $V_{IN} = 24\text{V}$, $R_{ON} = 200\text{k}\Omega$.

Symbol	Parameter	Conditions	Min	Typ	Max	Unit
Startup Regulator						
V_{CC} Reg	V_{CC} Regulator Output		6.6	7	7.4	V
	V_{CC} Current Limit	(2)		11		mA
V_{CC} Supply						
	V_{CC} undervoltage Lockout Voltage (V_{CC} increasing)			6.3		V
	V_{CC} Undervoltage Hysteresis			206		mV
	V_{CC} UVLO Delay (filter)			3		μs
	Operating Current (I_{CC})	Non-Switching, $\text{FB} = 3\text{V}$		500	675	μA
	Shutdown/Standby Current	$R_{ON}/SD = 0\text{V}$		70	150	μA
Switch Characteristics						
	Buck Switch $R_{ds(on)}$	$I_{TEST} = 200\text{mA}$, $V_{BST} - V_{SW} = 6.3\text{V}^{(3)}$		0.74	1.34	Ω
	Gate Drive UVLO ($V_{BST} - V_{SW}$)	Rising	3.4	4.5	5.5	V
	Gate Drive UVLO Hysteresis			400		mV
Current Limit						
	Current Limit Threshold		535	725	900	mA
	Current Limit Response Time	I_{switch} Overdrive = 0.1A Time to Switch Off		225		ns
	OFF time generator (test 1)	$\text{FB}=0\text{V}$, $\text{RCL} = 100\text{K}$		17		μs
	OFF time generator (test 2)	$\text{FB}=2.3\text{V}$, $\text{RCL} = 100\text{K}$		2.65		μs
On Time Generator						
	TON -1	$V_{in} = 10\text{V}$ $R_{on} = 200\text{K}$	2.15	2.77	3.5	μs
	TON -2	$V_{in} = 40\text{V}$ $R_{on} = 200\text{K}$	450	615	810	ns
	Remote Shutdown Threshold	Rising	0.45	0.7	1.1	V
	Remote Shutdown Hysteresis			40		mV
Minimum Off Time						
	Minimum Off Timer	$\text{FB} = 0\text{V}$		300		ns
Regulation and OV Comparators						
	FB Reference Threshold	Internal reference Trip point for switch ON	2.445	2.5	2.550	V
	FB Over-Voltage Threshold	Trip point for switch OFF		2.875		V
	FB Bias Current			100		nA
Thermal Shutdown						
T_{sd}	Thermal Shutdown Temp.			165		$^\circ\text{C}$
	Thermal Shutdown Hysteresis			25		$^\circ\text{C}$
Thermal Resistance						
θ_{JA}	Junction to Ambient	DGK Package		200		$^\circ\text{C}/\text{W}$
		NGT Package		40		$^\circ\text{C}/\text{W}$

- (1) All limits are guaranteed. All electrical characteristics having room temperature limits are tested during production with $T_A = T_J = 25^\circ\text{C}$. All hot and cold limits are guaranteed by correlating the electrical characteristics to process and temperature variations and applying statistical process control.
- (2) The V_{CC} output is intended as a self bias for the internal gate drive power and control circuits. Device thermal limitations limit external loading.
- (3) For devices procured in the WSON-8 package the $R_{ds(on)}$ limits are guaranteed by design characterization data only.

Typical Performance Characteristics

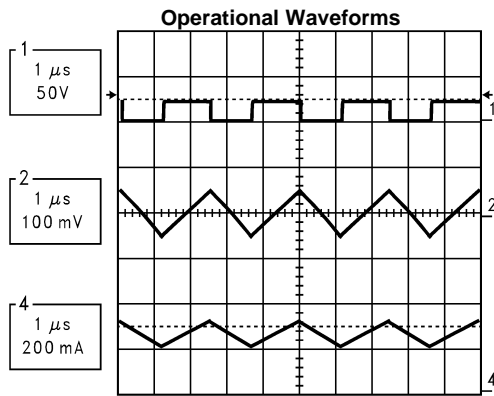

LM25007 Operation: $V_{OUT} = 10V$, $V_{IN} = 20V$, $I_{OUT} = 250mA$
 CH1: Switch Node, CH2: V_{OUT} (AC), CH4: Inductor Current

Figure 1.

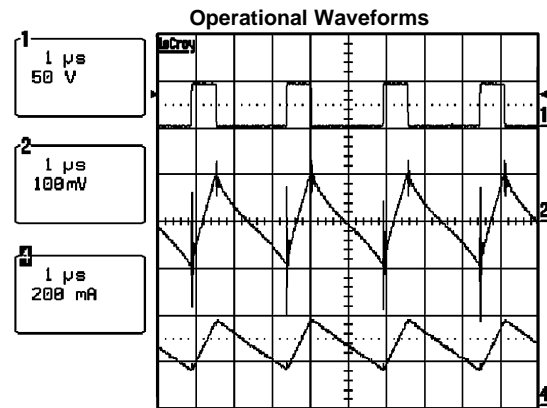

LM25007 Operation: $V_{OUT} = 10V$, $V_{IN} = 42V$, $I_{OUT} = 250mA$
 CH1: Switch Node, CH2: V_{OUT} (AC), CH4: Inductor Current

Figure 2.

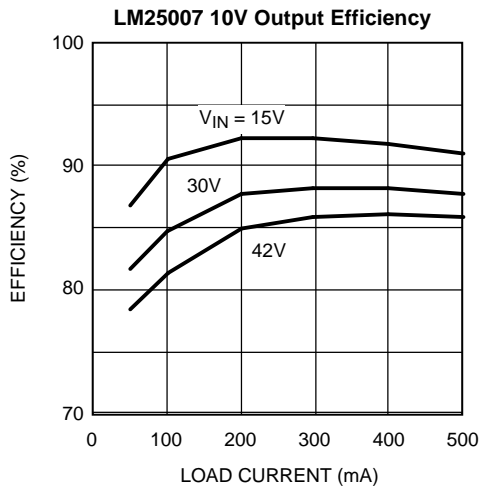

Figure 3.

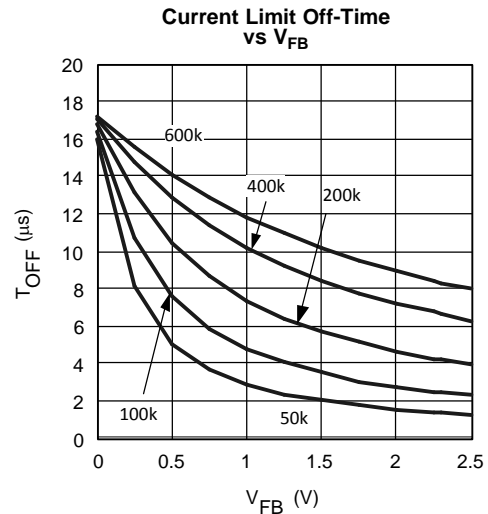

Figure 4.

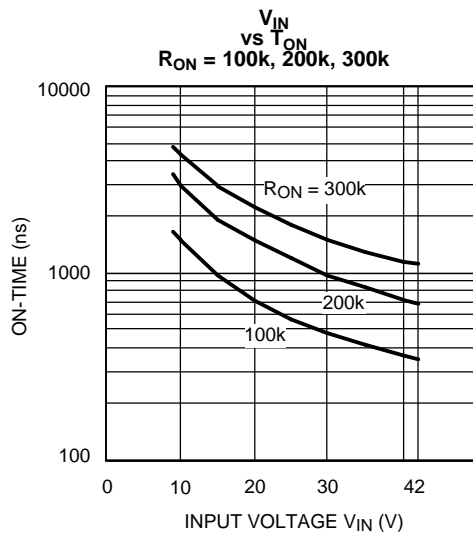

Figure 5.

DETAILED OPERATING DESCRIPTION

The LM25007 is a monolithic step-down switching regulator featuring all of the functions needed to implement low cost, efficient, power supply. Capable of driving a 0.5Amp load over a 9-42V input voltage range, this device is easy to apply and is provided in the small VSSOP-8 and the thermally enhanced WSON-8 packages. Ultra-fast transient response is achieved through the use of a constant on-time architecture with Vin feed forward. This feature provides an almost constant operating frequency over load and input voltage variations. The operating frequency may be adjusted up to 800kHz depending on input and output voltages. This architecture is easy to use and tolerant of component selection. An intelligent current limit is implemented in the LM25007 with forced off time that is inversely proportional to Vout to ensure recovery from fault conditions. The output voltage may be set from 2.5V to >30V. To improve efficiency in light load applications, the Vcc pin can be tied to an external voltage source thus eliminating the drop through the integrated internal regulator. Additional protection features include: thermal shutdown, Vcc under-voltage lockout, gate drive under-voltage lockout, and max duty cycle limiter.

Hysteretic Control Circuit Overview

The LM25007 is a Buck DC-DC regulator that uses a constant on-time control scheme. The on-time is programmed by an external resistor and varies inversely with line input voltage (Vin). The core regulation elements of the LM25007 are the feedback comparator and the on-time one-shot. The regulator output voltage is sensed at the feedback pin (FB) and is compared to an internal reference voltage (2.5V). If the FB signal is below the reference voltage, the buck switch is turned on for a fixed time pulse determined by the line voltage and a programming resistor (RON). Following the on period the switch will remain off for at least the minimum off timer period of 300ns. If the FB pin voltage is still below the reference after the 300ns off-time, the switch will turn on again for another on time period. This switching behavior will continue until the FB pin voltage reaches the reference voltage level.

The LM25007 operates in discontinuous conduction mode at light load currents or continuous conduction mode at heavier load currents. In discontinuous conduction mode, current through the output inductor starts at zero and ramps up to a peak value during the buck switch on-time and then back to zero during the off-time. The inductor current remains at zero until the next on-time period starts when FB falls below the internal reference. In discontinuous mode the operating frequency is relatively low and will vary with load. Therefore at light loads the conversion efficiency is maintained, since the switching losses decrease with the reduction in load current and switching frequency. The approximate discontinuous mode operating frequency can be calculated as follows:

$$F = \frac{V_{OUT}^2 \times L}{1 \times 10^{-20} \times R_{Load} \times (R_{ON})^2} \quad (1)$$

In continuous conduction mode, current flows continuously through the inductor and never ramps down to zero. In this mode the operating frequency is greater than the discontinuous mode frequency and remains relatively constant with load and line variations. The approximate continuous mode operating frequency can be calculated as follows:

$$F = \frac{V_{OUT}}{1.42 \times 10^{-10} \times R_{ON}} \quad (2)$$

The output voltage (Vout) can be programmed by two external resistors as shown in [Figure 6](#). The regulated voltage is calculated as follows:

$$V_{OUT} = 2.5 \times (R3 + R4) / R4 \quad (3)$$

The feedback comparator in hysteretic regulators depends on the output ripple voltage to switch the output transistor on and off at regular intervals. In order for the internal comparator to respond quickly to changes in output voltage, proportional to inductor current, a minimum amount of capacitor Equivalent Series Resistance (ESR) is required. A ripple voltage of 25mV is recommended at the feedback pin (FB) for stable operation. In cases where the intrinsic capacitor ESR is too small, additional series resistance may be added.

For applications where lower output voltage ripple is required the load can be connected directly to the low ESR output capacitor, as shown in Figure 6. The series resistor (R5) will degrade the load regulation. Another technique for enhancing the ripple voltage at the FB pin is to place a capacitor in parallel with the feedback divider resistor R3. The addition of the capacitor reduces the attenuation of the ripple voltage from the feedback divider.

High Voltage Bias Regulator (VCC)

The LM25007 contains an internal high voltage bias regulator. The input pin (Vin) can be connected directly to line voltages from 9 to 42 Volts. To avoid supply voltage transients due to long lead inductances on the input pin (VIN), it is always recommended to connect a low ESR ceramic chip capacitor ($\approx 0.1\mu\text{F}$) between VIN and RTN pins located close to the LM25007. The regulator is internally current limited to 11mA. Upon power up, the regulator is enabled and sources current into an external capacitor connected to the VCC pin. When the voltage on the VCC pin reaches its UVLO level (6.3V), the controller output is enabled.

An external auxiliary supply voltage can be diode connected to the Vcc pin. If the auxiliary voltage is greater than 7 Volts the internal regulator will shutoff, thus reducing internal power dissipation. Do not exceed 14V at VCC. See Figure 7.

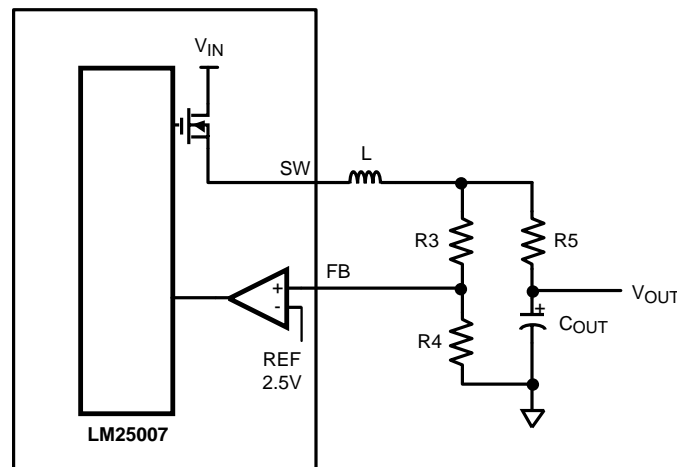

Figure 6. Low Ripple Output Configuration

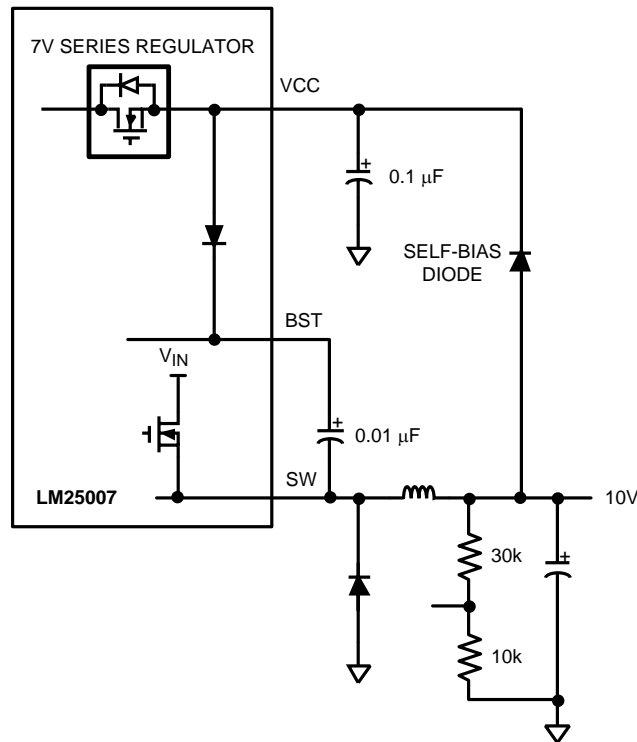

Figure 7. Self Biased Configuration

Over-Voltage Comparator

The over-voltage comparator is provided to protect the output from overvoltage conditions due to sudden input line voltage changes or output loading changes. The over-voltage comparator monitors the FB pin versus an internal 2.875V reference. If the voltage at FB rises above 2.875V the comparator immediately terminates the buck switch on-time pulse.

ON Time generator and Shutdown

The on-time of the LM25007 is set inversely proportional to the input voltage by an external resistor connected between RON/SD and VIN. The RON/SD terminal is a low impedance input biased at approximately 1.5V. The current through the resistor and into the RON/SD pin is approximately proportional to Vin and used internally to control the on-timer. This scheme of input voltage feed-forward hysteretic operation achieves nearly constant operational frequency over varying line and load conditions. The on-time equation for the LM25007 is :

$$T_{on} = 1.42 \times 10^{-10} \times R_{ON} / V_{IN} \quad (4)$$

The RON/SD pin of the LM25007 also provides a shutdown function which disables the regulator and significantly decreases quiescent power dissipation. By pulling the pin below 0.7V activates the low power shutdown mode. The VIN quiescent current in the shutdown mode is approximately 100μA internal to the LM25007 plus the current in the RON resistor. See Figure 8.

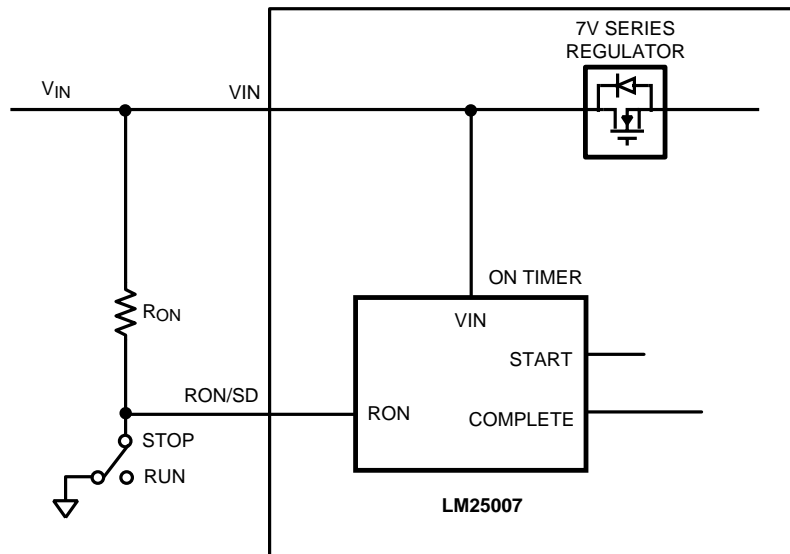

Figure 8. Shutdown Implementation

Current Limit

The LM25007 contains an intelligent current limit off-timer intended to reduce the foldback characteristic inherent with fixed off-time over-current protection. If the current in the Buck switch exceeds 725mA the present cycle on-time is immediately terminated (cycle by cycle current limit). Following the termination of the cycle a non-resettable current limit off timer is initiated. The duration of the off time is a function of the external resistor (R_{CL}) and the FB pin voltage. When the FB pin voltage equals zero, the current limit off-time is internally preset to 17 μ s. This condition occurs in short circuit operation when a maximum amount of off-time is required.

In cases of overload (not complete short circuit) the current limit off-time is reduced as a function of the output voltage (measured at the FB pin). Reducing the off-time with smaller overloads reduces the amount of foldback and also reduces the initial start-up time. The current limit off time for a given FB pin voltage and R_{CL} resistor can be calculated by the following equation:

$$T_{off} = 10^{-5} / (0.59 + (V_{FB} / 7.22 \times 10^{-6} \times R_{CL})) \quad (5)$$

Applications utilizing low resistance inductors and/or a low voltage drop rectifier may require special evaluation at high line, short circuit conditions. In this special case the preset 17 μ s ($FB = 0V$) off-time may be insufficient to balance the inductor volt*time product. Additional inductor resistance, output resistance or a larger voltage drop rectifier may be necessary to balance the inductor cycle volt*time product and limit the short circuit current.

N - Channel Buck Switch and Driver

The LM25007 integrates an N-Channel Buck switch and associated floating high voltage gate driver. The gate driver circuit works in conjunction with an external bootstrap capacitor and an internal high voltage diode. The bootstrap capacitor is charged by V_{CC} through the internal high voltage diode. A 0.01 μ F ceramic capacitor connected between the BST pin and SW pin is recommended.

During each cycle when the Buck switch turns off, the SW pin is approximately 0V. When the SW pin voltage is low, the bootstrap capacitor is charged from V_{CC} through the internal diode. The minimum off timer, set to 300ns, ensures that there will be a minimum interval every cycle to recharge the bootstrap capacitor.

An external re-circulating diode from the SW pin to ground is necessary to carry the inductor current after the internal Buck switch turns off. This external diode must be of the Ultra-fast or Schottky type to reduce turn-on losses and current over-shoot. The reverse voltage rating of the re-circulating diode must be greater than the maximum line input voltage.

Thermal Protection

Internal Thermal Shutdown circuitry is provided to protect the integrated circuit in the event the maximum junction temperature is exceeded. When thermal protection is activated, typically at 165 degrees Celsius, the controller is forced into a low power reset state, disabling the output driver. This feature is provided to prevent catastrophic failures from accidental device overheating.

Minimum Load Current

A minimum load current of 1 mA is required to maintain proper operation. If the load current falls below that level, the bootstrap capacitor may discharge during the long off-time, and the circuit will either shutdown, or cycle on and off at a low frequency. If the load current is expected to drop below 1 mA in the application, the feedback resistors should be chosen low enough in value so they provide the minimum required current at nominal Vout.

10V, 400mA Demo Board Bill of Materials

See [Typical Application Circuit and Block Diagram](#)

Table 1. Bill of Materials

ITEM	PART NUMBER	DESCRIPTION	VALUE
C1	C4532X7R2A105M	CAPACITOR, CER, TDK	1 μ , 100V
C2	C4532X7R1E156M	CAPACITOR, CER, TDK	15 μ , 25V
C3	C1206C104K5RAC	CAPACITOR, CER, KEMET	0.1 μ , 50V
C4	C1206C103K5RAC	CAPACITOR, CER, KEMET	0.01 μ , 50V
C5	C3216X7R2A104KT	CAPACITOR, CER, TDK	0.1 μ , 100V
D1	MURA110T3	DIODE, 100V, ON SEMI	
L1	SLF7045T-101MR60-1	BUCK INDUCTOR, TDK	100 μ H
R1	CRCW12062003F	RESISTOR	200K
R2	CRCW12061003F	RESISTOR	100K
R3	CRCW12063011F	RESISTOR	3.01K
R4	CRCW12061001F	RESISTOR	1K
R5	CRCW12061R00F	RESISTOR	1
U1	LM25007	REGULATOR, TI	

REVISION HISTORY

Changes from Revision B (February 2013) to Revision C	Page
• Changed layout of National Data Sheet to TI format	11

PACKAGING INFORMATION

Orderable part number	Status (1)	Material type (2)	Package Pins	Package qty Carrier	RoHS (3)	Lead finish/ Ball material (4)	MSL rating/ Peak reflow (5)	Op temp (°C)	Part marking (6)
LM25007MM/NOPB	Active	Production	VSSOP (DGK) 8	1000 SMALL T&R	Yes	SN	Level-1-260C-UNLIM	-40 to 125	SLYB
LM25007MM/NOPB.A	Active	Production	VSSOP (DGK) 8	1000 SMALL T&R	Yes	SN	Level-1-260C-UNLIM	-40 to 125	SLYB
LM25007MM/NOPB.B	Active	Production	VSSOP (DGK) 8	1000 SMALL T&R	Yes	SN	Level-1-260C-UNLIM	-40 to 125	SLYB
LM25007MMX/NOPB	Active	Production	VSSOP (DGK) 8	3500 LARGE T&R	Yes	SN	Level-1-260C-UNLIM	-40 to 125	SLYB
LM25007MMX/NOPB.A	Active	Production	VSSOP (DGK) 8	3500 LARGE T&R	Yes	SN	Level-1-260C-UNLIM	-40 to 125	SLYB
LM25007MMX/NOPB.B	Active	Production	VSSOP (DGK) 8	3500 LARGE T&R	Yes	SN	Level-1-260C-UNLIM	-40 to 125	SLYB
LM25007SD/NOPB	Active	Production	WSON (NGT) 8	1000 SMALL T&R	Yes	SN	Level-1-260C-UNLIM	-40 to 125	25007SD
LM25007SD/NOPB.A	Active	Production	WSON (NGT) 8	1000 SMALL T&R	Yes	SN	Level-1-260C-UNLIM	-40 to 125	25007SD
LM25007SD/NOPB.B	Active	Production	WSON (NGT) 8	1000 SMALL T&R	Yes	SN	Level-1-260C-UNLIM	-40 to 125	25007SD
LM25007SDX/NOPB	Active	Production	WSON (NGT) 8	4500 LARGE T&R	Yes	SN	Level-1-260C-UNLIM	-40 to 125	25007SD
LM25007SDX/NOPB.A	Active	Production	WSON (NGT) 8	4500 LARGE T&R	Yes	SN	Level-1-260C-UNLIM	-40 to 125	25007SD
LM25007SDX/NOPB.B	Active	Production	WSON (NGT) 8	4500 LARGE T&R	Yes	SN	Level-1-260C-UNLIM	-40 to 125	25007SD

(1) **Status:** For more details on status, see our [product life cycle](#).

(2) **Material type:** When designated, preproduction parts are prototypes/experimental devices, and are not yet approved or released for full production. Testing and final process, including without limitation quality assurance, reliability performance testing, and/or process qualification, may not yet be complete, and this item is subject to further changes or possible discontinuation. If available for ordering, purchases will be subject to an additional waiver at checkout, and are intended for early internal evaluation purposes only. These items are sold without warranties of any kind.

(3) **RoHS values:** Yes, No, RoHS Exempt. See the [TI RoHS Statement](#) for additional information and value definition.

(4) **Lead finish/Ball material:** Parts may have multiple material finish options. Finish options are separated by a vertical ruled line. Lead finish/Ball material values may wrap to two lines if the finish value exceeds the maximum column width.

(5) **MSL rating/Peak reflow:** The moisture sensitivity level ratings and peak solder (reflow) temperatures. In the event that a part has multiple moisture sensitivity ratings, only the lowest level per JEDEC standards is shown. Refer to the shipping label for the actual reflow temperature that will be used to mount the part to the printed circuit board.

(6) **Part marking:** There may be an additional marking, which relates to the logo, the lot trace code information, or the environmental category of the part.

Multiple part markings will be inside parentheses. Only one part marking contained in parentheses and separated by a "-" will appear on a part. If a line is indented then it is a continuation of the previous line and the two combined represent the entire part marking for that device.

Important Information and Disclaimer: The information provided on this page represents TI's knowledge and belief as of the date that it is provided. TI bases its knowledge and belief on information provided by third parties, and makes no representation or warranty as to the accuracy of such information. Efforts are underway to better integrate information from third parties. TI has taken and continues to take reasonable steps to provide representative and accurate information but may not have conducted destructive testing or chemical analysis on incoming materials and chemicals. TI and TI suppliers consider certain information to be proprietary, and thus CAS numbers and other limited information may not be available for release.

In no event shall TI's liability arising out of such information exceed the total purchase price of the TI part(s) at issue in this document sold by TI to Customer on an annual basis.

TAPE AND REEL INFORMATION

QUADRANT ASSIGNMENTS FOR PIN 1 ORIENTATION IN TAPE

*All dimensions are nominal

Device	Package Type	Package Drawing	Pins	SPQ	Reel Diameter (mm)	Reel Width W1 (mm)	A0 (mm)	B0 (mm)	K0 (mm)	P1 (mm)	W (mm)	Pin1 Quadrant
LM25007MM/NOPB	VSSOP	DGK	8	1000	177.8	12.4	5.3	3.4	1.4	8.0	12.0	Q1
LM25007MMX/NOPB	VSSOP	DGK	8	3500	330.0	12.4	5.3	3.4	1.4	8.0	12.0	Q1
LM25007SD/NOPB	WSO	NGT	8	1000	177.8	12.4	4.3	4.3	1.3	8.0	12.0	Q1
LM25007SDX/NOPB	WSO	NGT	8	4500	330.0	12.4	4.3	4.3	1.3	8.0	12.0	Q1

TAPE AND REEL BOX DIMENSIONS

*All dimensions are nominal

Device	Package Type	Package Drawing	Pins	SPQ	Length (mm)	Width (mm)	Height (mm)
LM25007MM/NOPB	VSSOP	DGK	8	1000	210.0	185.0	35.0
LM25007MMX/NOPB	VSSOP	DGK	8	3500	367.0	367.0	35.0
LM25007SD/NOPB	WSON	NGT	8	1000	210.0	185.0	35.0
LM25007SDX/NOPB	WSON	NGT	8	4500	367.0	367.0	35.0

NGT0008A



PACKAGE OUTLINE

WSON - 0.8 mm max height

PLASTIC SMALL OUTLINE - NO LEAD

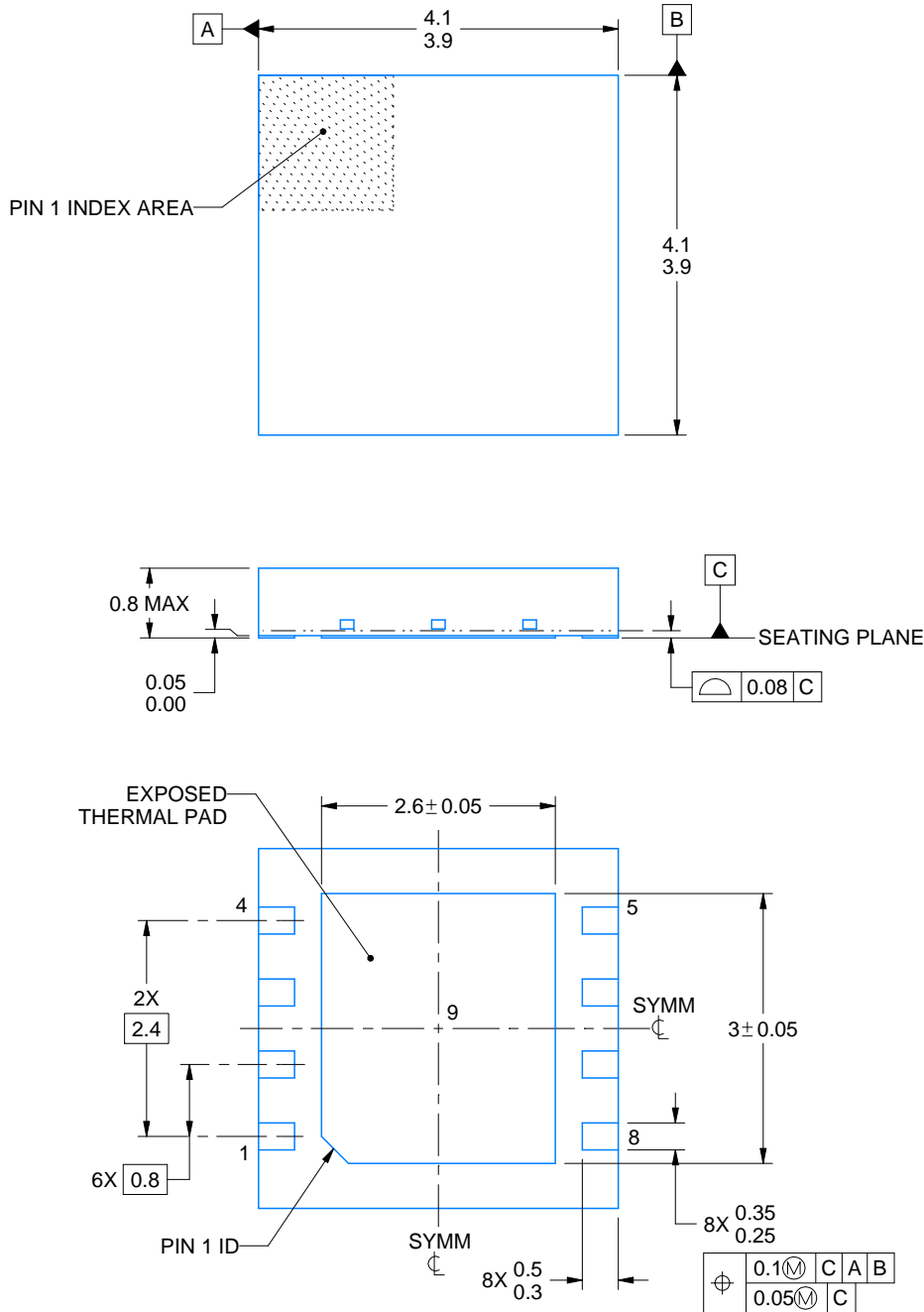

4214935/A 08/2020

NOTES:

1. All linear dimensions are in millimeters. Any dimensions in parenthesis are for reference only. Dimensioning and tolerancing per ASME Y14.5M.
2. This drawing is subject to change without notice.
3. The package thermal pad must be soldered to the printed circuit board for thermal and mechanical performance.

EXAMPLE BOARD LAYOUT

NGT0008A

WSON - 0.8 mm max height

PLASTIC SMALL OUTLINE - NO LEAD

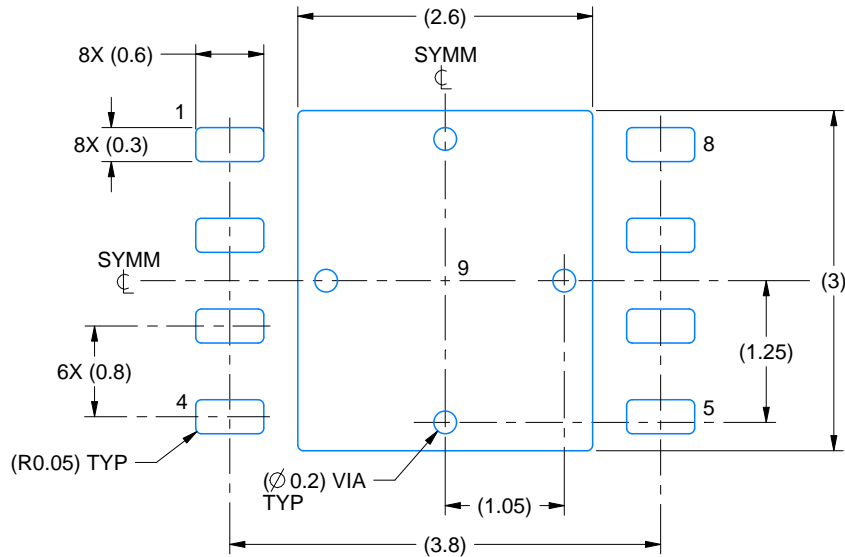

LAND PATTERN EXAMPLE
EXPOSED METAL SHOWN
SCALE:15X



SOLDER MASK DETAILS

4214935/A 08/2020

NOTES: (continued)

4. This package is designed to be soldered to a thermal pad on the board. For more information, see Texas Instruments literature number SLUA271 (www.ti.com/lit/sluea271).
5. Vias are optional depending on application, refer to device data sheet. If any vias are implemented, refer to their locations shown on this view. It is recommended that vias under paste be filled, plugged or tented.

EXAMPLE STENCIL DESIGN

NGT0008A

WSON - 0.8 mm max height

PLASTIC SMALL OUTLINE - NO LEAD

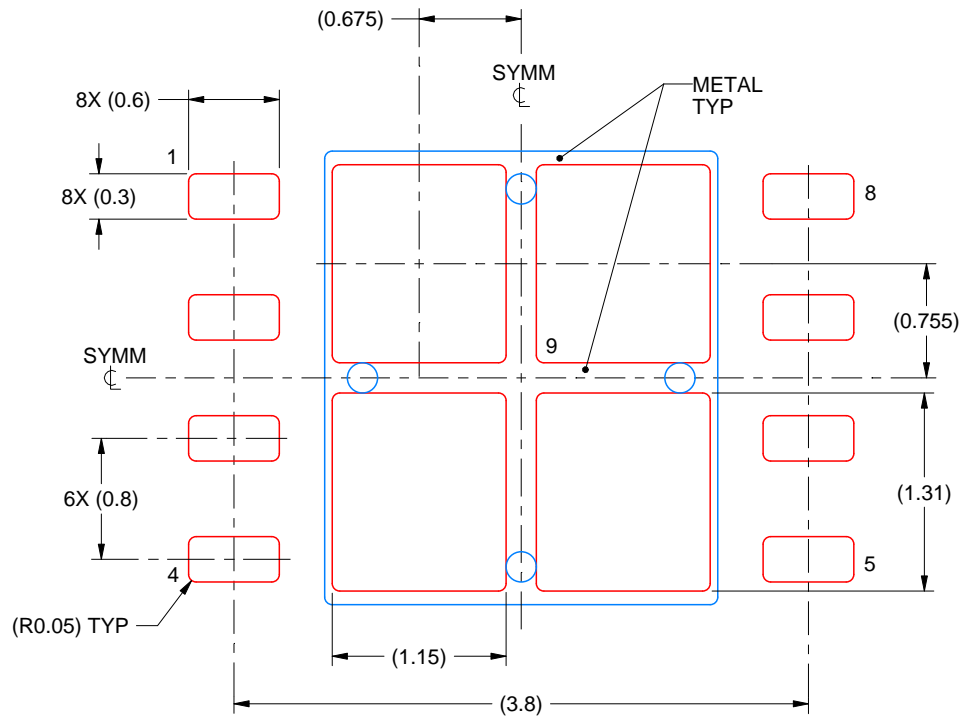

SOLDER PASTE EXAMPLE
BASED ON 0.125 mm THICK STENCIL

EXPOSED PAD 9:
77% PRINTED SOLDER COVERAGE BY AREA UNDER PACKAGE
SCALE:20X

4214935/A 08/2020

NOTES: (continued)

6. Laser cutting apertures with trapezoidal walls and rounded corners may offer better paste release. IPC-7525 may have alternate design recommendations.

DGK0008A



PACKAGE OUTLINE

VSSOP - 1.1 mm max height

SMALL OUTLINE PACKAGE



4214862/A 04/2023

NOTES:

PowerPAD is a trademark of Texas Instruments.

1. All linear dimensions are in millimeters. Any dimensions in parenthesis are for reference only. Dimensioning and tolerancing per ASME Y14.5M.
2. This drawing is subject to change without notice.
3. This dimension does not include mold flash, protrusions, or gate burrs. Mold flash, protrusions, or gate burrs shall not exceed 0.15 mm per side.
4. This dimension does not include interlead flash. Interlead flash shall not exceed 0.25 mm per side.
5. Reference JEDEC registration MO-187.

EXAMPLE BOARD LAYOUT

DGK0008A

™ VSSOP - 1.1 mm max height

SMALL OUTLINE PACKAGE



LAND PATTERN EXAMPLE
EXPOSED METAL SHOWN
SCALE: 15X



SOLDER MASK DETAILS

4214862/A 04/2023

NOTES: (continued)

6. Publication IPC-7351 may have alternate designs.
7. Solder mask tolerances between and around signal pads can vary based on board fabrication site.
8. Vias are optional depending on application, refer to device data sheet. If any vias are implemented, refer to their locations shown on this view. It is recommended that vias under paste be filled, plugged or tented.
9. Size of metal pad may vary due to creepage requirement.

EXAMPLE STENCIL DESIGN

DGK0008A

™ VSSOP - 1.1 mm max height

SMALL OUTLINE PACKAGE



SOLDER PASTE EXAMPLE
SCALE: 15X

4214862/A 04/2023

NOTES: (continued)

11. Laser cutting apertures with trapezoidal walls and rounded corners may offer better paste release. IPC-7525 may have alternate design recommendations.
12. Board assembly site may have different recommendations for stencil design.

IMPORTANT NOTICE AND DISCLAIMER

TI PROVIDES TECHNICAL AND RELIABILITY DATA (INCLUDING DATASHEETS), DESIGN RESOURCES (INCLUDING REFERENCE DESIGNS), APPLICATION OR OTHER DESIGN ADVICE, WEB TOOLS, SAFETY INFORMATION, AND OTHER RESOURCES "AS IS" AND WITH ALL FAULTS, AND DISCLAIMS ALL WARRANTIES, EXPRESS AND IMPLIED, INCLUDING WITHOUT LIMITATION ANY IMPLIED WARRANTIES OF MERCHANTABILITY, FITNESS FOR A PARTICULAR PURPOSE OR NON-INFRINGEMENT OF THIRD PARTY INTELLECTUAL PROPERTY RIGHTS.

These resources are intended for skilled developers designing with TI products. You are solely responsible for (1) selecting the appropriate TI products for your application, (2) designing, validating and testing your application, and (3) ensuring your application meets applicable standards, and any other safety, security, regulatory or other requirements.

These resources are subject to change without notice. TI grants you permission to use these resources only for development of an application that uses the TI products described in the resource. Other reproduction and display of these resources is prohibited. No license is granted to any other TI intellectual property right or to any third party intellectual property right. TI disclaims responsibility for, and you fully indemnify TI and its representatives against any claims, damages, costs, losses, and liabilities arising out of your use of these resources.

TI's products are provided subject to [TI's Terms of Sale](#), [TI's General Quality Guidelines](#), or other applicable terms available either on [ti.com](#) or provided in conjunction with such TI products. TI's provision of these resources does not expand or otherwise alter TI's applicable warranties or warranty disclaimers for TI products. Unless TI explicitly designates a product as custom or customer-specified, TI products are standard, catalog, general purpose devices.

TI objects to and rejects any additional or different terms you may propose.

Copyright © 2025, Texas Instruments Incorporated

Last updated 10/2025