

LM5137-Q1 Automotive, 4V to 80V 100% Duty Cycle Capable, Dual-Channel, Synchronous Buck DC/DC Controller

1 Features

- AEC-Q100 qualified for automotive applications:
 - Device temperature grade 1: -40°C to 125°C ambient operating temperature
- **Functional Safety-Capable**
 - [Documentation available to aid functional safety system design](#)
- Functional Safety-Compliant [options](#) – ASIL B and ASIL D – available through [request](#) (LM5137F-Q1)
- Dual-channel synchronous buck DC/DC controller
 - Wide input voltage range of 4V to 80V
 - 1% accurate, fixed 3.3V, 5V, 12V, or adjustable outputs from 0.8V to 60V
 - 150°C maximum junction temperature
 - Charge-pump gate drivers for 100% duty cycle
- Two interleaved synchronous buck channels
 - Dual channel or single-output multiphase
 - Stackable up to four phases
 - SYNC in and SYNC out capability
- Inherent protection features for robust design
 - Internal hiccup-mode overcurrent protection
 - Independent ENABLE and PGOOD functions
 - Adjustable output voltage soft start
 - VCC and gate-drive UVLO protection
 - Thermal shutdown protection with hysteresis
- Designed for ultra-low EMI requirements
 - Dual Random Spread Spectrum ([DRSS](#))
 - Switching frequency from 100kHz to 2.64MHz
- VQFN-36 [package](#) with wettable flanks
- Create a custom design using the LM5137-Q1 with [WEBENCH® Power Designer](#)

2 Applications

- [48V_{IN} automotive, body electronics and lighting](#)
- [Infotainment and cluster, ADAS](#)
- [Hybrid, electric, and powertrain systems](#)
- [High-voltage battery-operated systems](#)

3 Description

The LM5137-Q1 is an 80V synchronous buck DC/DC controller offered from a family with three [options](#) for functional safety: Capable, ASIL B, and ASIL D. The device uses an interleaved, stackable, peak current-mode architecture for easy loop compensation, fast transient response, excellent load and line regulation, and accurate current sharing with paralleled phases for high output current.

A high-side switch minimum on-time of 22ns facilitates large step-down ratios, enabling the direct conversion from 12V, 24V, or 48V automotive inputs to low-voltage rails for reduced system design cost and complexity. The LM5137-Q1 continues to operate during input voltage dips as low as 4V, at 100% duty cycle if needed. The $1.5\mu\text{A}$ sleep quiescent current with the output voltage in regulation extends operating run-time in battery-powered automotive systems.

Package Information

PART NUMBER	PACKAGE ⁽¹⁾	PACKAGE SIZE ⁽²⁾
LM5137-Q1	RHA (VQFN, 36)	6.0mm × 6.0mm

(1) For more information, see [Section 11](#).

(2) The package size (length × width) is a nominal value and includes pins, where applicable.

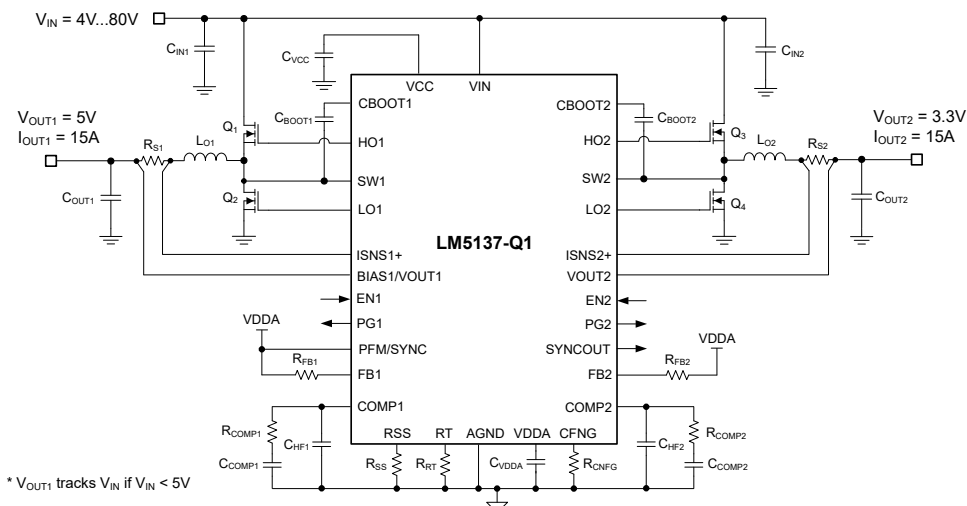

* V_{OUT1} tracks V_{IN} if $V_{IN} < 5\text{V}$

LM5137-Q1 Dual-Output Buck Switching Regulator – Simplified Schematic



An IMPORTANT NOTICE at the end of this data sheet addresses availability, warranty, changes, use in safety-critical applications, intellectual property matters and other important disclaimers. PRODUCTION DATA.

Several features are included to simplify compliance with CISPR 25 and automotive EMI requirements. Adaptively timed, high-current MOSFET gate drivers minimize body diode conduction during switching transitions, reducing switching losses and improving thermal and EMI performance at high input voltage and high switching frequency. To reduce input capacitor ripple current and EMI filter size, 180° interleaved operation is provided for two outputs. A 90° out-of-phase clock output works well for cascaded, multichannel or multiphase power stages. Resistor-adjustable switching frequency as high as 2.2MHz can be synchronized to an external clock source up to 2.64MHz to eliminate beat frequencies in noise-sensitive applications.

Additional features of the LM5137-Q1 include 150°C maximum junction temperature operation, user-selectable PFM mode for lower current consumption during light-load conditions, configurable soft-start function, open-drain PG flags for fault reporting and output monitoring, independent enable inputs, monotonic start-up into prebiased loads, integrated VCC bias supply regulator powered from VIN or VOUT1, hiccup-mode overload protection, and thermal shutdown protection with automatic recovery. Current is sensed using the inductor DCR for highest efficiency or an optional shunt resistor for high accuracy.

The LM5137-Q1 controller is qualified to AEC-Q100 grade 1 for automotive applications and comes in a 6mm × 6mm, thermally-enhanced, 36-pin VQFN package with additional pin clearance for increased reliability and wettable flank pins to facilitate optical inspection during manufacturing. The wide input voltage range, low quiescent current consumption, high-temperature operation, cycle-by-cycle current limit, low EMI signature, and [small design size](#) provide an excellent point-of-load regulator choice for applications requiring enhanced robustness and durability.

Table of Contents

1 Features	1	7.4 Device Functional Modes	30
2 Applications	1	8 Application and Implementation	31
3 Description	1	8.1 Application Information.....	31
4 Related Products	4	8.2 Typical Applications.....	39
5 Pin Configuration and Functions	5	8.3 Power Supply Recommendations.....	55
5.1 Wettable Flanks.....	7	8.4 Layout.....	56
6 Specifications	8	9 Device and Documentation Support	62
6.1 Absolute Maximum Ratings.....	8	9.1 Device Support.....	62
6.2 ESD Ratings.....	8	9.2 Documentation Support.....	63
6.3 Recommended Operating Conditions.....	9	9.3 Receiving Notification of Documentation Updates....	64
6.4 Thermal Information.....	9	9.4 Support Resources.....	64
6.5 Electrical Characteristics.....	9	9.5 Trademarks.....	64
6.6 Typical Characteristics.....	13	9.6 Electrostatic Discharge Caution.....	64
7 Detailed Description	18	9.7 Glossary.....	64
7.1 Overview.....	18	10 Revision History	65
7.2 Functional Block Diagram.....	19	11 Mechanical, Packaging, and Orderable Information	65
7.3 Feature Description.....	20		

4 Related Products

Table 4-1. Orderable Part Numbers

GENERIC PART NUMBER	ORDERABLE PART NUMBER	TI FUNCTIONAL SAFETY CLASSIFICATION ⁽¹⁾	PRODUCT DATA SHEET
LM5137-Q1	LM5137QRHARQ1	Functional safety-capable	This data sheet
LM5137F-Q1	LM5137FBQRHARQ1	ASIL B functional safety-compliant	Request here
	LM5137FDQRHARQ1	ASIL D functional safety-compliant	

- (1) Refer to the [functional safety homepage](#) to understand the TI functional safety classifications (in terms of the development process, analysis report, and diagnostics description).

5 Pin Configuration and Functions

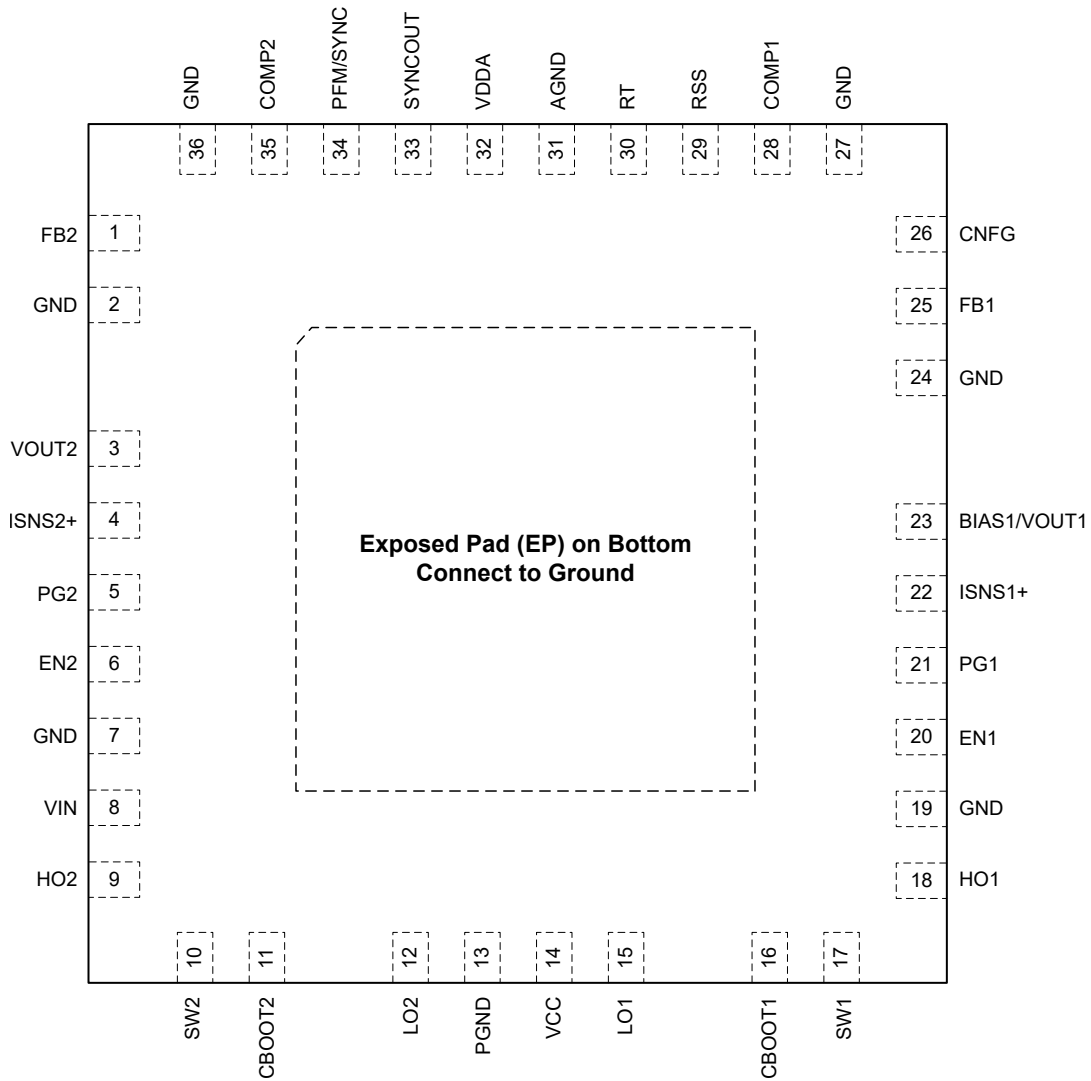

Connect the exposed pad on the bottom to AGND and PGND on the PCB.

Figure 5-1. RHA Package, 36-Pin VQFN With Wettable Flanks (Top View)

Table 5-1. Pin Functions

PIN		TYPE ⁽¹⁾	DESCRIPTION
NAME	NO.		
FB2	1	I	Connect FB2 through a 7.5kΩ, 24.9kΩ or 48.7kΩ resistor to VDDA to set the output voltage at 3.3V, 5V or 12V, respectively. Alternatively, use a resistive divider from VOUT2 to FB2 to set the output voltage setpoint of channel 2 between 0.8V and 60V. The FB2 regulation voltage is 0.8V.
VOUT2	3	I	Output voltage sense and the current sense amplifier input of channel 2. Connect VOUT2 to the output side of the channel 2 current sense resistor (or to the relative sense capacitor terminal if inductor DCR current sensing is used).
ISNS2+	4	I	Channel 2 current sense amplifier input. Connect ISNS2+ to the inductor side of the external current sense resistor (or to the relevant sense capacitor terminal if inductor DCR current sensing is used) using a low-current Kelvin connection.
PG2	5	O	An open-drain output that goes low if VOUT2 is outside a specific regulation window
EN2	6	I	An active high input ($V_{EN2} > 1V$ typical) enables channel 2. If $V_{EN2} < 0.5V$, channel 2 is disabled and is in shutdown mode unless a SYNC signal is present at PFM/SYNC. EN2 must never be left floating.
VIN	8	P	Supply voltage input source for the VCC regulator
HO2	9	P	Channel 2 high-side gate driver output
SW2	10	P	Switching node of the channel 2 buck regulator. Connect to the bootstrap capacitor, the source terminal of the high-side MOSFET, and the drain terminal of the low-side MOSFET.
CBOOT2	11	P	Channel 2 high-side driver supply for bootstrap gate drive
LO2	12	P	Channel 2 low-side gate driver output
PGND	13	G	Power ground connection pin for the low-side MOSFET gate driver
VCC	14	P	VCC bias supply pin. Connect a ceramic capacitor between VCC and PGND.
LO1	15	P	Channel 1 low-side gate driver output
CBOOT1	16	P	Channel 1 high-side driver supply for bootstrap gate drive
SW1	17	P	Switching node of the channel 1 buck regulator. Connect to the bootstrap capacitor, the source terminal of the high-side MOSFET, and the drain terminal of the low-side MOSFET.
HO1	18	P	Channel 1 high-side gate driver output
EN1	20	I	An active high input ($V_{EN1} > 1V$ typical) enables channel 1. If $V_{EN1} < 0.5V$, channel 1 is disabled and is in shutdown mode unless a SYNC signal is present at PFC/SYNC. EN1 must never be left floating.
PG1	21	O	An open-collector output that goes low if VOUT1 is outside a specified regulation window.
ISNS1+	22	I	Channel 1 current sense amplifier input. Connect ISNS1+ to the inductor side of the external current sense resistor (or to the relevant sense capacitor terminal if inductor DCR current sensing is used) using a low-current Kelvin connection.
BIAS1/ VOUT1	23	I	If $V_{BIAS1} > 4.3V$, BIAS1 becomes the supply voltage to the internal VCC regulator. BIAS1 also acts as the primary VOUT1 sensing and the current sense amplifier input for channel 1. Connect BIAS/VOUT1 to the output side of the channel 1 current sense resistor.
CNFG	26	I	Connect a resistor from CNFG to GND to set the output configuration and to activate DRSS at one of two modulation frequencies (or to disable). See also Table 7-1 .
FB1	25	I	Connect FB1 through a 7.5kΩ, 24.9kΩ or 48.7kΩ resistor to VDDA to set the output voltage at 3.3V, 5V or 12V, respectively. Alternatively, use a resistive divider from VOUT1 to FB1 to set the output voltage setpoint of channel 1 between 0.8V and 60V. The FB1 regulation voltage is 0.8V.
COMP1	28	O	Output of the channel 1 transconductance error amplifier. COMP1 is high impedance in interleaved or secondary mode. Pulling COMP1 below 100mV in interleaved mode disables the HO1 and LO1 gate driver outputs.
RSS	29	I	Connect a resistor from RSS to GND to set the soft-start time between 1.5ms and 20ms
RT	30	O	Frequency programming pin. A resistor from RT to AGND sets the oscillator frequency between 100kHz and 2.2MHz.
AGND	31	G	Analog ground connection. Ground return for the internal voltage reference and analog circuits.
VDDA	32	P	Internal analog bias regulator output. Connect a 1μF ceramic decoupling capacitor from VDDA to AGND.
SYNCOUT	33	O	SYNCOUT is a logic-level signal with a rising edge approximately 90° lagging HO1 (or 90° leading HO2). When SYNCOUT is used to synchronize a second LM5137-Q1 controller, the phases operate at 0°, 90°, 180° and 270° as needed.

Table 5-1. Pin Functions (continued)

PIN		TYPE ⁽¹⁾	DESCRIPTION
NAME	NO.		
PFM/SYNC	34	I	Connect PFM/SYNC to VDDA to operate the LM5137-Q1 in PFM mode. Connect PFM/SYNC to GND to enable forced PWM (FPWM) mode with continuous conduction at light loads. Use PFM/SYNC as a synchronization input to synchronize the internal oscillator to an external clock.
COMP2	35	O	Output of the channel 2 transconductance error amplifier. COMP2 is high impedance in single-output interleaved mode. Pulling COMP2 below 100mV in interleaved mode disables the HO2 and LO2 gate driver outputs.
GND	2, 7, 19, 24, 27, 36	G	Unused pins – connect to the exposed pad on the PCB.

(1) P = Power, G = Ground, I = Input, O = Output

5.1 Wettable Flanks

100% automated visual inspection (AVI) post-assembly is typically required to meet requirements for high reliability and robustness. Standard quad-flat no-lead (QFN) packages do not have solderable or exposed pins and terminals that are easily viewed. Visually determining whether or not the package is successfully soldered onto the printed-circuit board (PCB) is therefore difficult. The wettable-flank process was developed to resolve the issue of side-lead wetting of leadless packaging. The LM5137-Q1 is assembled using a 36-pin VQFN package with wettable flanks to provide a visual indicator of solderability, which reduces inspection time and manufacturing costs.

6 Specifications

6.1 Absolute Maximum Ratings

Over the recommended operating junction temperature range of -40°C to 150°C (unless otherwise noted). ⁽¹⁾

		MIN	MAX	UNIT
Input voltage	VIN to PGND	-0.3	85	V
	SW1, SW2 to PGND	-0.3	85	V
	SW1, SW2 to PGND, transient < 20ns	-5		V
	BIAS1/VOUT1, VOUT2 to AGND	-0.3	85	V
	FB1, FB2 to AGND	-0.3	20	V
	PFM/SYNC, RT, CNFG, RSS to AGND	-0.3	6.5	V
	CNFG to AGND	-0.3	5.5	V
	AGND to PGND	-0.3	0.3	V
	ISNS1+, ISNS2+ to AGND	-0.3	85	V
	EN1, EN2 to PGND	-0.3	$V_{IN} + 5$	V
Output voltage	PG1, PG2 to AGND	-0.3	$V_{IN} + 5$	V
	CBOOT1 to SW1, CBOOT2 to SW2	-0.3	6.5	V
	CBOOT1 to SW1, CBOOT2 to SW2, transient < 20ns	-0.3	6.5	V
	HO1 to SW1, HO2 to SW2	-0.3	$V_{CBOOT1/2} + 0.3$	V
	HO1 to SW1, HO2 to SW2, transient < 20ns	-0.5		V
	LO1, LO2 to PGND	-0.3	$V_{VCC} + 0.3$	V
	LO1, LO2 to PGND, transient < 20ns	-5		V
	VCC, VDDA, SYNCOUT to AGND	-0.3	6.5	V
Operating junction temperature, T_J		-40	150	$^{\circ}\text{C}$
Storage temperature, T_{stg}		-55	150	$^{\circ}\text{C}$

- (1) Operation outside the Absolute Maximum Ratings may cause permanent device damage. Absolute Maximum Ratings do not imply functional operation of the device at these or any other conditions beyond those listed under [Recommended Operating Conditions](#). If used outside the Recommended Operating Conditions but within the Absolute Maximum Ratings, the device may not be fully functional, and this may affect device reliability, functionality, performance, and shorten the device lifetime.

6.2 ESD Ratings

			VALUE	UNIT	
$V_{(ESD)}$	Electrostatic discharge	Human body model (HBM), per AEC Q100-002 ⁽¹⁾	± 2000	V	
		Charged device model (CDM), per AEC Q100-011	Corner pins (1, 9, 10, 17, 18, 26, 27 and 36)		± 750
			Other pins		± 500

- (1) AEC Q100-002 indicates that HBM stressing must be in accordance with the ANSI/ESDA/JEDEC JS-001 specification.

6.3 Recommended Operating Conditions

Over the operating junction temperature range of -40°C to 150°C (unless otherwise noted). ⁽¹⁾

		MIN	NOM	MAX	UNIT
V _{IN}	Input supply voltage range	4		80	V
V _{OUT}	Output voltage range	0.8		60	V
	SW1, SW2 to PGND	-0.3		80	V
	HO1 to SW1, HO2 to SW2	-0.3	V _{CBOOT1/2} + 0.3		V
	CBOOT1 to SW1, CBOOT2 to SW2	-0.3	5	5.3	V
	FB1, FB2 to AGND	-0.3		15	V
	EN1, EN2, PG1, PG2 to AGND	-0.3		V _{IN}	V
	ISNS1+, ISNS2+, BIAS1/VOUT1, VOUT2 to AGND	-0.3		80	V
	VCC, VDDA, RSS to PGND	-0.3	5	5.3	V
I _{SYNCOUT}	SYNCOUT current			2	mA
	PGND to AGND	-0.3		0.3	V
T _J	Operating junction temperature	-40		150	$^{\circ}\text{C}$

(1) Recommended operating conditions are conditions under which the device is intended to be functional. For specifications and test conditions, see [Electrical Characteristics](#).

6.4 Thermal Information

THERMAL METRIC ⁽¹⁾		LM5137-Q1	UNIT
		RHA (VQFN)	
		36 PINS	
R _{θJA}	Junction-to-ambient thermal resistance	33.2	$^{\circ}\text{C}/\text{W}$
R _{θJC(top)}	Junction-to-case (top) thermal resistance	24.2	$^{\circ}\text{C}/\text{W}$
R _{θJB}	Junction-to-board thermal resistance	14.1	$^{\circ}\text{C}/\text{W}$
ψ _{JT}	Junction-to-top characterization parameter	0.4	$^{\circ}\text{C}/\text{W}$
ψ _{JB}	Junction-to-board characterization parameter	14	$^{\circ}\text{C}/\text{W}$
R _{θJC(bot)}	Junction-to-case (bottom) thermal resistance	3.6	$^{\circ}\text{C}/\text{W}$

(1) For more information about traditional and new thermal metrics, see the [Semiconductor and IC Package Thermal Metrics](#) application note.

6.5 Electrical Characteristics

Typical values are at T_J = 25 $^{\circ}\text{C}$. Minimum and maximum limits apply at T_J = -40°C to 150°C . V_{IN} = 12V, unless otherwise stated.

PARAMETER		TEST CONDITIONS	MIN	TYP	MAX	UNIT
INPUT SUPPLY (VIN)						
I _{Q-SHDN}	VIN shutdown current	V _{EN1} = V _{EN2} = 0V		3.6		μA
I _{Q-SHDN-48V}	VIN shutdown current	V _{EN1} = V _{EN2} = 0V, V _{IN} = 48V		6		μA
I _{Q-STBY}	VIN standby current	0.6V < V _{EN1/2} < 1V		260		μA
I _{Q-SLEEP}	VIN sleep current, V _{VOUT1} = 5V, V _{VOUT2} = 3.3V	1.05V ≤ V _{EN1/2} ≤ V _{IN} , V _{VOUT1} = 5V, V _{VOUT2} = 3.3V, in regulation at no load, not switching, V _{PFM/SYNC} = 5V		1.5		μA
I _{Q-SLEEP-48V}	VIN sleep current, V _{VOUT1} = 5V, V _{VOUT2} = 3.3V, V _{IN} = 48V	1.05V ≤ V _{EN1/2} ≤ V _{IN} , V _{VOUT1} = 5V, V _{VOUT2} = 3.3V, in regulation, no load, not switching, V _{PFM/SYNC} = 5V, V _{IN} = 48V		3.1		μA
INTERNAL LDO (VCC)						
V _{VCC-REG}	VCC regulation voltage	I _{VCC} = 0mA	4.7	5.0	5.3	V
V _{VCC-UVLO}	VCC UVLO rising threshold		3.7	3.8	3.9	V
V _{VCC-UVLO-HYST}	VCC UVLO hysteresis			300		mV
I _{VCC-REG}	VCC short-circuit current limit		175	300		mA
INTERNAL LDO (VDDA)						

6.5 Electrical Characteristics (continued)

Typical values are at $T_J = 25^\circ\text{C}$. Minimum and maximum limits apply at $T_J = -40^\circ\text{C}$ to 150°C . $V_{IN} = 12\text{V}$, unless otherwise stated.

PARAMETER		TEST CONDITIONS	MIN	TYP	MAX	UNIT
$V_{VDDA-REG}$	VDDA regulation voltage			5		V
R_{VDDA}	VDDA resistance to VCC			12		Ω
EXTERNAL BIAS (BIAS1)						
$V_{BIAS-ON}$	$V_{BIAS1/VOUT1}$ rising		4.1	4.3	4.5	V
$V_{BIAS-HYST}$	Bias hysteresis voltage			130		mV
REFERENCE VOLTAGE (FB1, FB2)						
V_{REF1}	Regulated FB voltage		792	800	808	mV
PRECISION ENABLE (EN1, EN2)						
$V_{SDN1/2}$	Shutdown-to-standby threshold	$V_{EN1/2}$ rising		0.6		V
$V_{EN1/2-HIGH}$	Enable voltage rising threshold	$V_{EN1/2}$ rising, switching enabled	0.95	1.0	1.05	V
$V_{EN1/2-HYS}$	Enable hysteresis voltage			50		mV
$I_{EN1/2-HYS}$	Enable hysteresis current	$V_{EN1/2} = 1.1\text{V}$	-12	-10	-8	μA
OUTPUT VOLTAGE (VOUT1/BIAS1, VOUT2)						
$V_{OUT1/2-3.3\text{V}}$	3.3V fixed output setpoint	$R_{FB1/2} = 7.5\text{k}\Omega$, $4\text{V} \leq V_{VIN} \leq 80\text{V}$	3.267	3.3	3.33	V
$V_{OUT1/2-5\text{V}}$	5V fixed output setpoint	$R_{FB1/2} = 24.9\text{k}\Omega$	4.95	5	5.05	V
$V_{OUT1/2-12\text{V}}$	12V fixed output setpoint	$R_{FB1/2} = 48.7\text{k}\Omega$, $13\text{V} \leq V_{VIN} \leq 80\text{V}$	11.82	12	12.18	V
ERROR AMPLIFIER (COMP1, COMP2)						
$g_{m1/2}$	EA transconductance	$\Delta V_{FB1/2} \pm 50\text{mV}$	400	600		μS
$V_{COMP1/2-CLAMP}$	COMP clamp voltage	$V_{FB1/2} = 0\text{V}$		1.75		V
$I_{COMP1/2-SRC}$	EA source current	$V_{COMP1/2} = 1\text{V}$, $V_{FB1/2} = 0.6\text{V}$		120		μA
$I_{COMP1/2-SINK}$	EA sink current	$V_{COMP1/2} = 1\text{V}$, $V_{FB1/2} = 1\text{V}$		120		μA
$V_{DRIVER1/2-DISABLE}$	COMP threshold voltage below which the driver is disabled			100		mV
POWER GOOD (PG1, PG2)						
$V_{PG1/2-OV}$	PG1/2 overvoltage	Rising threshold	103	105	107	%
$V_{PG1/2-OV-HYST}$	PG1/2 OV hysteresis			1		%
$V_{PG1/2-UV}$	PG1/2 undervoltage	Falling threshold	93	95	98	%
$V_{PG1-UV-HYST}$	PG1/2 UV hysteresis			1		%
$t_{PG1/2-DEGLITCH(R)}$	PG1/2 deglitch rising		1.4	2	2.6	ms
$t_{PG1/2-DEGLITCH(F)}$	PG1/2 deglitch falling		60	90	120	μs
$R_{PG1/2(on)}$	PG1/2 on resistance	Open drain, $I_{PG1/2} = 250\mu\text{A}$		100	250	Ω
SWITCHING FREQUENCY (RT)						
F_{SW1}	Switching frequency 1	$R_{RT} = 100\text{k}\Omega$ to AGND		230		kHz
F_{SW2}	Switching frequency 2	$R_{RT} = 10\text{k}\Omega$ to AGND	1.98	2.2	2.42	MHz
F_{SW3}	Switching frequency 3	$R_{RT} = 230\text{k}\Omega$ to AGND		100		kHz
$SLOPE_1$	Internal slope compensation 1	$R_{RT} = 10\text{k}\Omega$ to AGND		500		$\text{mV}/\mu\text{s}$
$SLOPE_2$	Internal slope compensation 2	$R_{RT} = 100\text{k}\Omega$ to AGND		42		$\text{mV}/\mu\text{s}$
$t_{ON(min)}$	PWM minimum on-time			22	35	ns
$t_{OFF(min)}$	PWM minimum off-time	Measured at nominal frequency, before the frequency folds back to achieve 100% duty cycle		45		ns
D_{MAX}	Maximum duty cycle			100		%
SYNCHRONIZATION OUTPUT (SYNCOUT)						
$V_{SYNCOUT-HO}$	SYNCOUT high-state voltage	$I_{SYNCOUT} = -4\text{mA}$	2			V
$V_{SYNCOUT-LO}$	SYNCOUT low-state voltage	$I_{SYNCOUT} = 4\text{mA}$			0.8	V
$t_{SYNCOUT1}$	Delay from HO1 rising edge to SYNCOUT rising edge	$V_{PFM/SYNC} = 0\text{V}$, $T_S = 1/F_{SW}$, F_{SW} set by $R_{RT} = 230\text{k}\Omega$		2.5		μs
$t_{SYNCOUT2}$	Delay from HO1 rising edge to SYNCOUT falling edge	$V_{PFM/SYNC} = 0\text{V}$, $T_S = 1/F_{SW}$, F_{SW} set by $R_{RT} = 230\text{k}\Omega$		7.5		μs

6.5 Electrical Characteristics (continued)

Typical values are at $T_J = 25^\circ\text{C}$. Minimum and maximum limits apply at $T_J = -40^\circ\text{C}$ to 150°C . $V_{IN} = 12\text{V}$, unless otherwise stated.

PARAMETER		TEST CONDITIONS	MIN	TYP	MAX	UNIT
PULSE FREQUENCY MODULATION and SYNCHRONIZATION INPUT (PFM/SYNC)						
$V_{\text{PFM-LO}}$	PFM detection threshold low				0.8	V
$V_{\text{PFM-HI}}$	PFM detection threshold high		1.2			V
$V_{\text{ZC-SW}}$	Zero-cross detection threshold			-5.5		mV
F_{SYNCIN}	Frequency synchronization range	$R_{\text{RT}} = 10\text{k}\Omega$, $\pm 20\%$ of the nominal oscillator frequency	1760		2640	kHz
$t_{\text{SYNC-MIN}}$	Minimum pulsewidth of external synchronization		20			ns
$t_{\text{SYNCIN-HO}}$	Delay from PFM/SYNC rising edge to HO1 rising edge			90		ns
$t_{\text{PFM-FILTER}}$	SYNCIN to PFM mode		14		70	μs
BOOTSTRAP CIRCUIT (CBOOT1, CBOOT2)						
$V_{\text{BOOT1/2-DROP}}$	Internal diode forward drop	$I_{\text{CBOOT1/2}} = 20\text{mA}$, V_{CC} to CBOOT1/2		0.8		V
$I_{\text{BOOT1/2}}$	CBOOT-to-SW quiescent current, not switching	$V_{\text{EN1/2}} = 5\text{V}$, $V_{\text{CBOOT1/2}} - V_{\text{SW1/2}} = 5\text{V}$		2		μA
$V_{\text{BOOT1/2-SW-UV-R}}$	CBOOT-to-SW UVLO rising threshold	$V_{\text{CBOOT1/2}} - V_{\text{SW1/2}}$ rising		2.7		V
$V_{\text{BOOT1/2-SW-UV-F}}$	CBOOT-to-SW UVLO falling threshold	$V_{\text{CBOOT1/2}} - V_{\text{SW1/2}}$ falling		2.47		V
$V_{\text{CHARGE-PUMP1/2-UNLOADED}}$	Charge pump output voltage	$I_{\text{CBOOT1/2}} = 0\mu\text{A}$		4.8		V
$I_{\text{CHARGE-PUMP1/2}}$	Charge pump output current	$V_{\text{CBOOT1/2}} = 3.5\text{V}$		20		μA
HIGH-SIDE GATE DRIVER (HO1, HO2)						
$V_{\text{HO1/2-HIGH}}$	HO1/2 high-state output voltage	$I_{\text{HO1/2}} = -100\text{mA}$		95		mV
$V_{\text{HO1/2-LOW}}$	HO1/2 low-state output voltage	$I_{\text{HO1/2}} = 100\text{mA}$		43		mV
$I_{\text{HO1/2-SRC}}$	HO1/2 peak source current	$V_{\text{HO1/2}} = V_{\text{SW1/2}} = 0\text{V}$		2		A
$I_{\text{HO1/2-SINK}}$	HO1/2 peak sink current	$V_{\text{CBOOT1/2}} - V_{\text{SW1/2}} = 5\text{V}$		3		A
LOW-SIDE GATE DRIVER (LO1, LO2)						
$V_{\text{LO1/2-HIGH}}$	LO1/2 high-state output voltage	$I_{\text{LO1/2}} = -100\text{mA}$		100		mV
$V_{\text{LO1/2-LOW}}$	LO1/2 low-state output voltage	$I_{\text{LO1/2}} = 100\text{mA}$		58		mV
$I_{\text{LO1/2-SRC}}$	LO1/2 peak source current	$V_{\text{LO1/2}} = 0\text{V}$		2		A
$I_{\text{LO1/2-SINK}}$	LO1/2 peak sink current	$V_{\text{VCC}} = 5\text{V}$		3		A
ADAPTIVE DEADTIME CONTROL						
t_{DEAD1}	HO1/2 off to LO1/2 deadtime			20		ns
t_{DEAD2}	LO1/2 off to HO1/2 on deadtime			20		ns
START-UP (RSS)						
R_{SS1}	1.5ms soft-start time	$R_{\text{SS1}} = 0\Omega$		1.5		ms
R_{SS2}	2ms soft-start time	$R_{\text{SS2}} = 8.06\text{k}\Omega$		2		ms
R_{SS3}	20ms soft-start time	$R_{\text{SS3}} = 95.3\text{k}\Omega$		20		ms
DUAL RANDOM SPREAD SPECTRUM (DRSS)						
f_m	Modulation frequency		7.2	12	16.8	kHz
$\Delta f_{\text{SS1/2-LF}}$	Low-frequency triangular spread spectrum modulation range1 maximum	$R_{\text{CNFG}} = 19.1\text{k}\Omega$ or $54.9\text{k}\Omega$	-5		5	%
$\Delta f_{\text{SS2-LF}}$	Low-frequency triangular spread spectrum modulation range2 maximum	$R_{\text{CNFG}} = 29.4\text{k}\Omega$ or $71.5\text{k}\Omega$	-10		10	%
OVERCURRENT PROTECTION (ISNS1+, ISNS2+)						
$V_{\text{CS1/2-TH}}$	Current limit threshold	Measured from ISNS1/2+ to VOUT1/2	54	60	66	mV
$t_{\text{DELAY1/2-ISNS+}}$	ISNS+ delay from $V_{\text{CS-TH}}$ to HO off			48		ns
$G_{\text{CS1/2}}$	CS amplifier gain		9.5	10	10.5	V/V
$V_{\text{CS-SHARE}}$	COMP to current accuracy	$V_{\text{COMP1/2}} = 1.2\text{V}$	54	60	66	mV
INTERNAL HICCUP MODE						
HIC_{DLY}	Hiccup-mode activation delay	$V_{\text{ISNS1/2+}} - V_{\text{VOUT1/2}} > 60\text{mV}$		512		cycles

6.5 Electrical Characteristics (continued)

Typical values are at $T_J = 25^\circ\text{C}$. Minimum and maximum limits apply at $T_J = -40^\circ\text{C}$ to 150°C . $V_{IN} = 12\text{V}$, unless otherwise stated.

PARAMETER		TEST CONDITIONS	MIN	TYP	MAX	UNIT
HIC _{TIME}	Hiccup-mode duration	$V_{ISNS1/2+} - V_{VOUT1/2} > 60\text{mV}$		16384		cycles
THERMAL SHUTDOWN						
T _{SHD}	Thermal shutdown threshold	Temperature rising		175		°C
T _{SHD-HYS}	Thermal shutdown hysteresis			15		°C

6.6 Typical Characteristics

$V_{IN} = 12V$, $T_J = 25^\circ C$, unless otherwise stated.

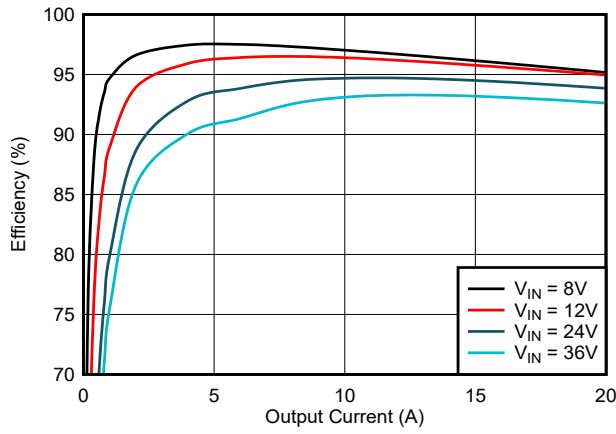

See [Figure 8-4](#) $V_{EN2} = 0V$ $F_{SW} = 440kHz$

Figure 6-1. Efficiency vs Load, 5V Output

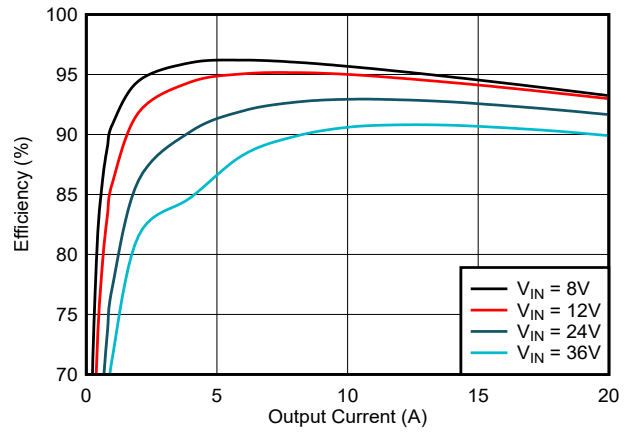

See [Figure 8-4](#) $V_{EN1} = 0V$ $F_{SW} = 440kHz$

Figure 6-2. Efficiency vs Load, 3.3V Output

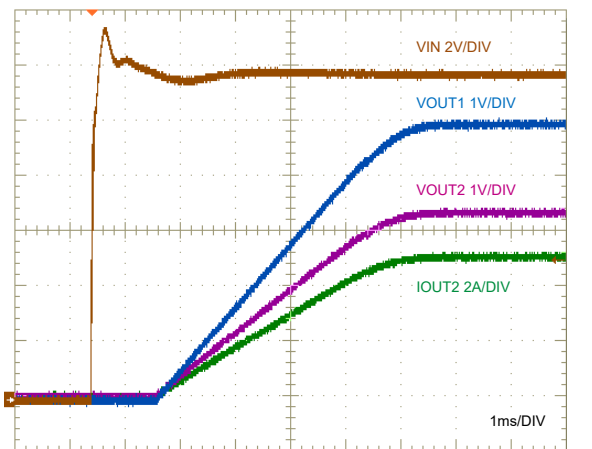

See [Figure 8-4](#) 5A resistive loads

Figure 6-3. Start-up Characteristic

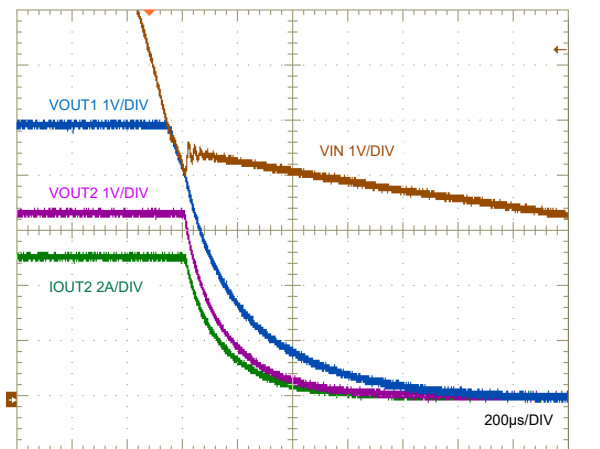

See [Figure 8-4](#) 5A resistive loads

Figure 6-4. Shutdown Characteristic

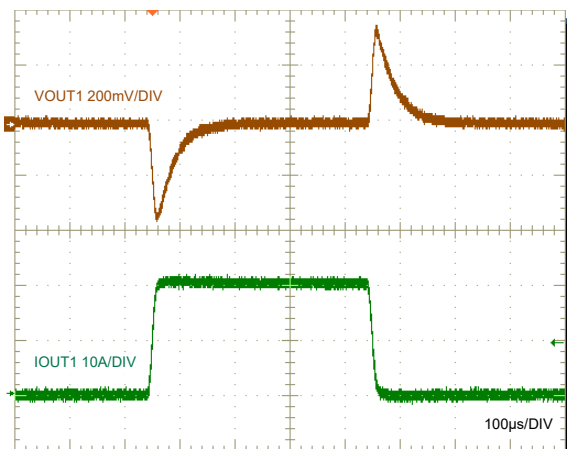

See [Figure 8-4](#) $V_{OUT1} = 5V$ 2A/ μs slew rate

Figure 6-5. Load Transient Response

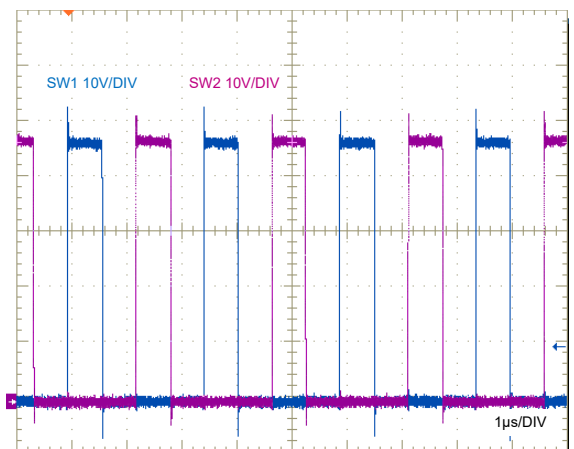

See [Figure 8-20](#) $V_{IN} = 48V$ $V_{OUT} = 12V$

Figure 6-6. Switch-Node Voltages

6.6 Typical Characteristics (continued)

$V_{IN} = 12V$, $T_J = 25^\circ C$, unless otherwise stated.

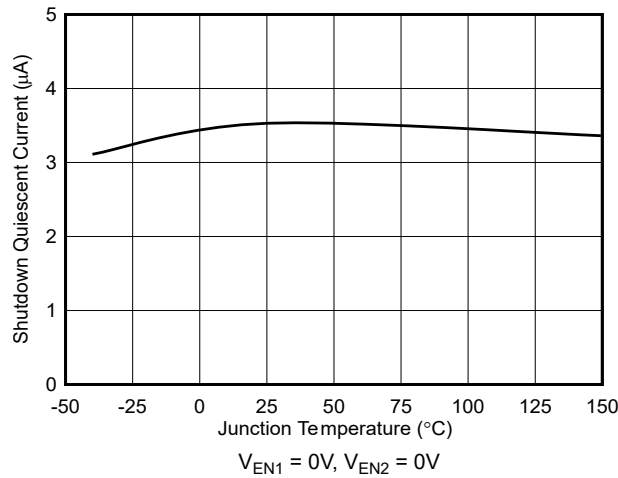

Figure 6-7. Shutdown Quiescent Current vs Temperature

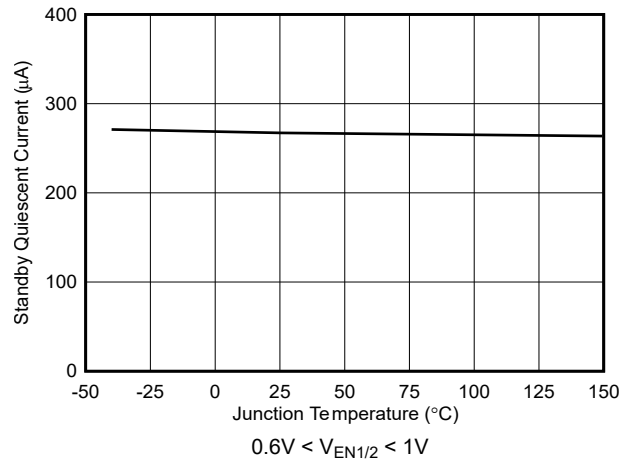

Figure 6-8. Standby Quiescent Current vs Temperature

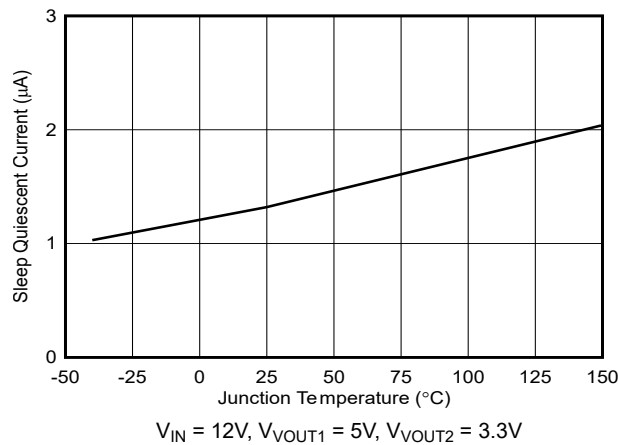

Figure 6-9. Sleep Quiescent Current vs Temperature

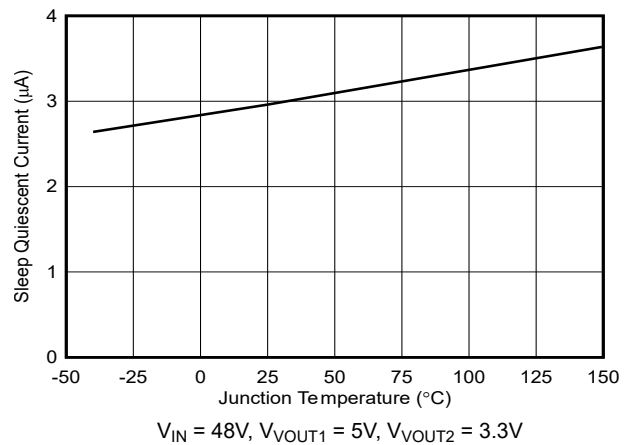

Figure 6-10. Sleep Quiescent Current vs Temperature

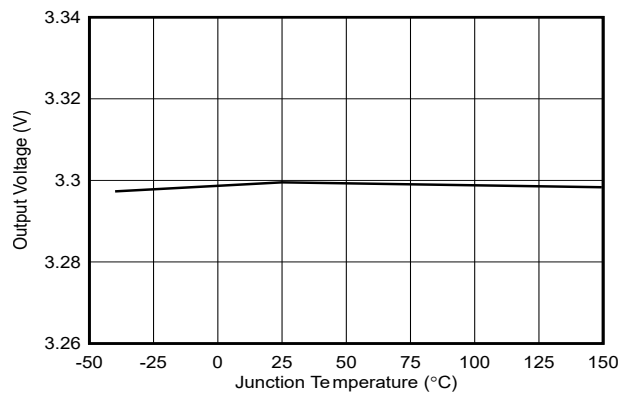

Figure 6-11. Fixed 3.3V Output Voltage vs Temperature

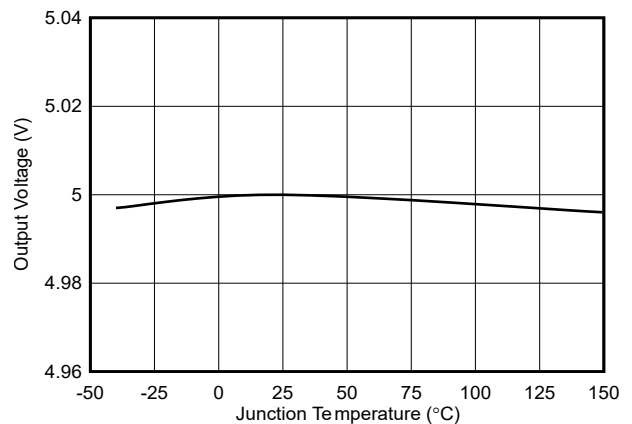

Figure 6-12. Fixed 5V Output Voltage vs Temperature

6.6 Typical Characteristics (continued)

$V_{IN} = 12V$, $T_J = 25^\circ C$, unless otherwise stated.

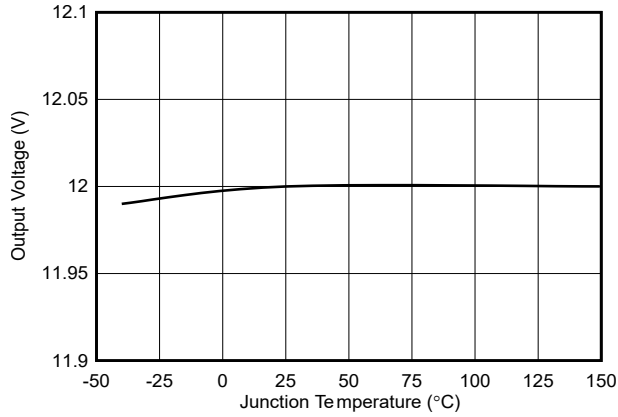

Figure 6-13. Fixed 12V Output Voltage vs Temperature

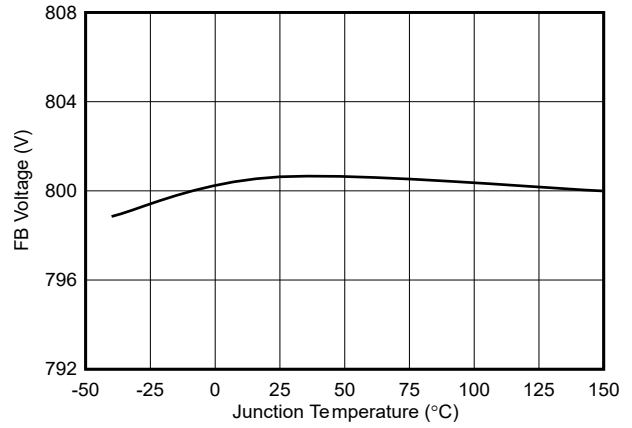

Figure 6-14. Feedback Voltage vs Temperature

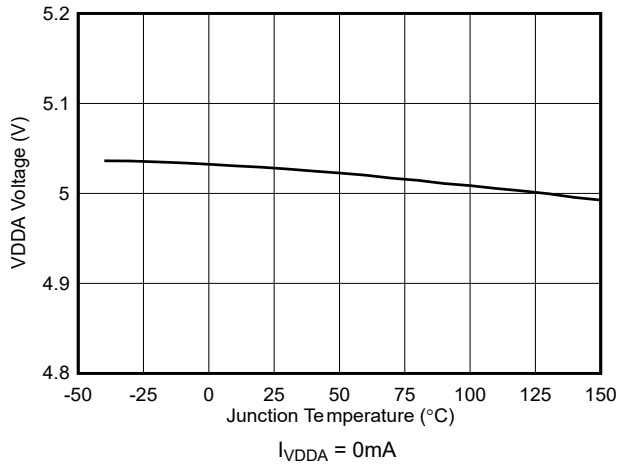

Figure 6-15. VDDA Regulation Voltage vs Temperature

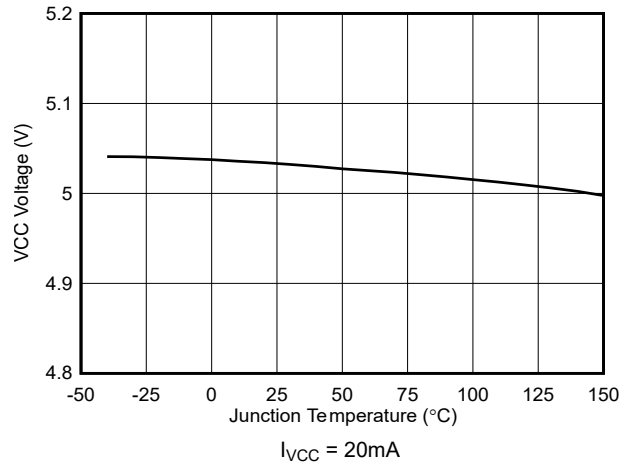

Figure 6-16. VCC Regulation Voltage vs Temperature

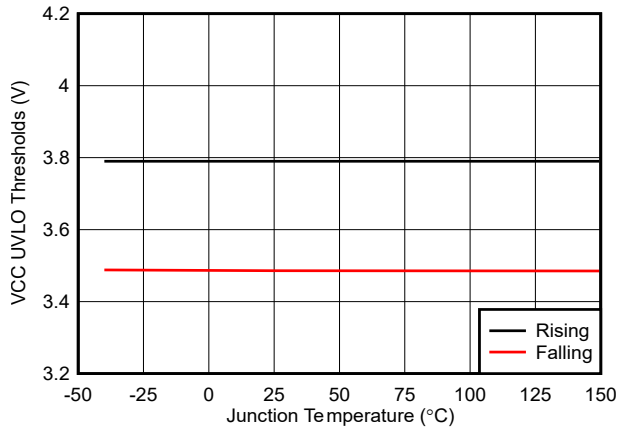

Figure 6-17. VCC UVLO Thresholds vs Temperature

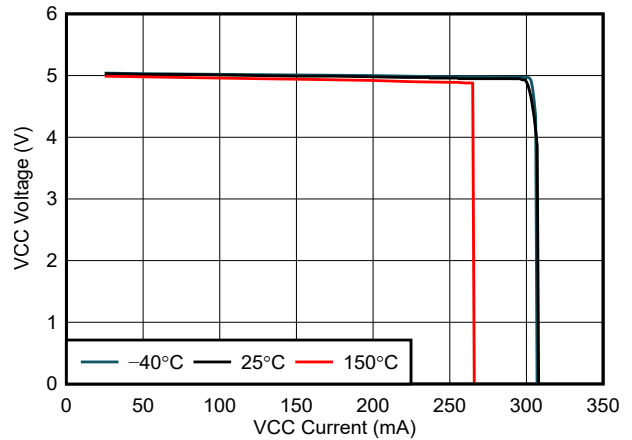

Figure 6-18. VCC Current Limit vs Temperature

6.6 Typical Characteristics (continued)

$V_{IN} = 12V$, $T_J = 25^\circ C$, unless otherwise stated.

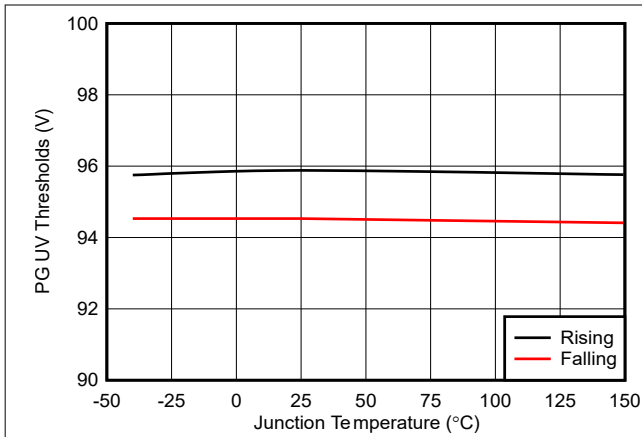

Figure 6-19. PG UV Thresholds vs Temperature

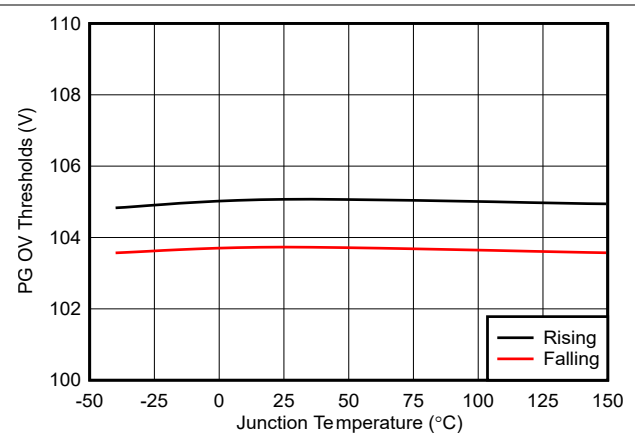

Figure 6-20. PG OV Thresholds vs Temperature

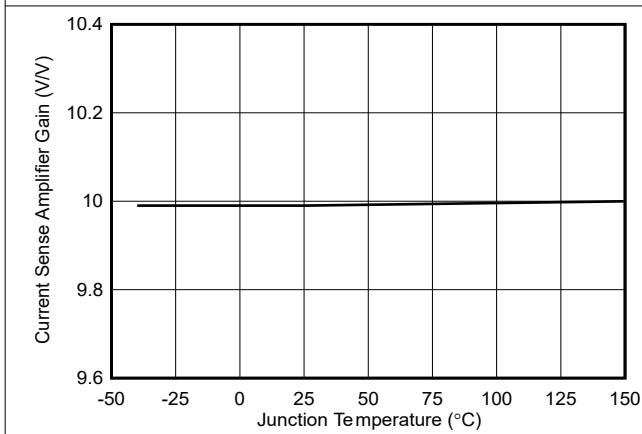

Figure 6-21. Current Sense Amplifier Gain vs Temperature

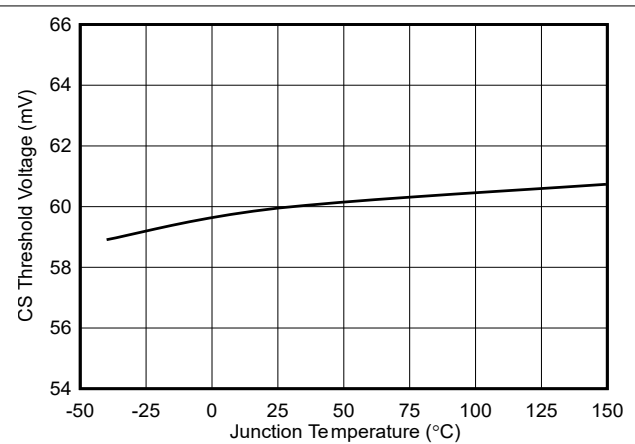

Figure 6-22. Current Sense Threshold vs Temperature

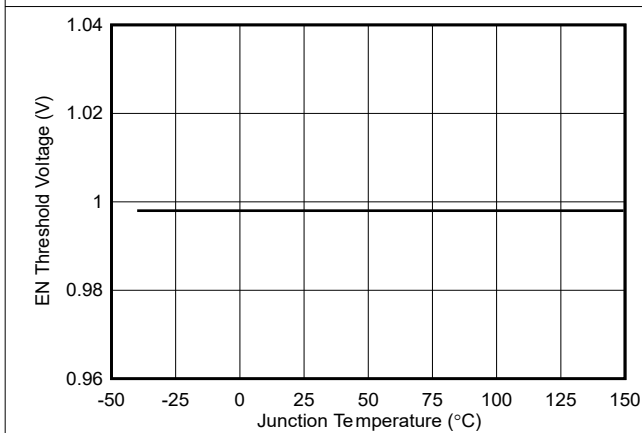

Figure 6-23. EN Rising Threshold Voltage vs Temperature

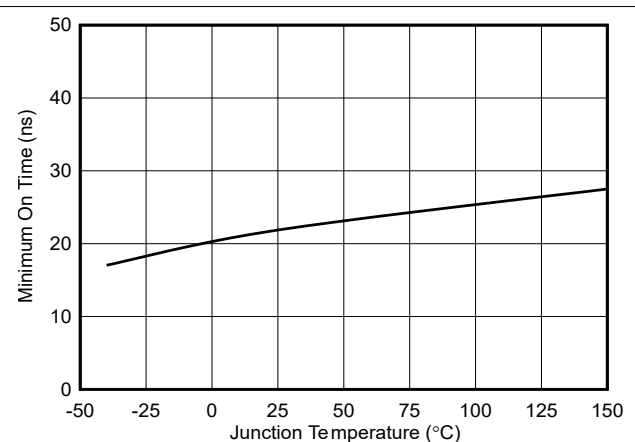

Figure 6-24. Minimum On Time vs Temperature

6.6 Typical Characteristics (continued)

$V_{IN} = 12V$, $T_J = 25^\circ C$, unless otherwise stated.

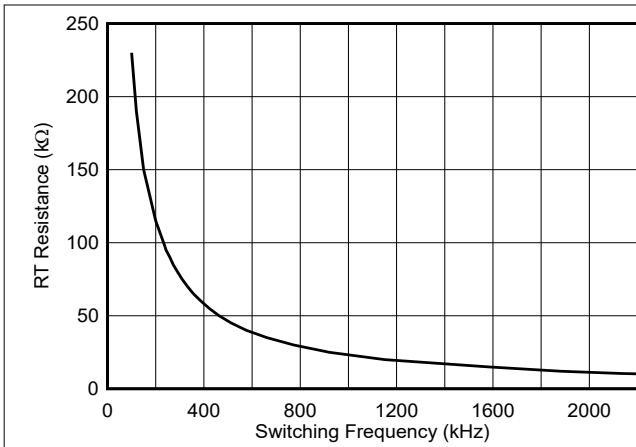

Figure 6-25. RT Resistance vs Switching Frequency

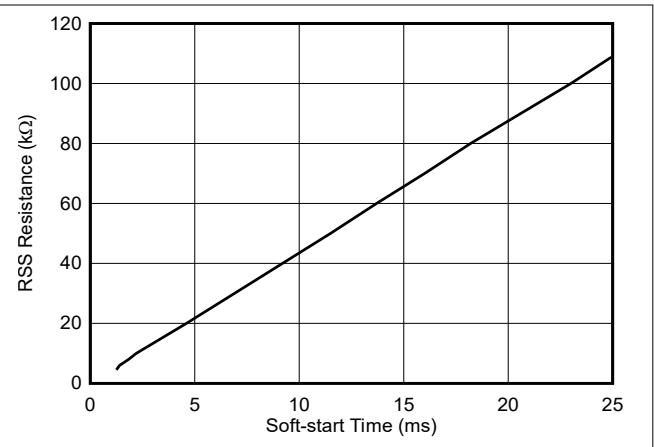

Figure 6-26. RSS Resistance vs Soft-start Time

7 Detailed Description

7.1 Overview

The LM5137-Q1 is a dual-channel, switching DC/DC controller that features all of the functions necessary to implement a high-efficiency synchronous buck regulator. The device is offered from a controller family with three [options](#) for functional safety applications: Capable, ASIL B, or ASIL D, with the latter two options designated by an "F" suffix in the part number.

Operating over a wide input voltage range from 4V to 80V, the LM5137-Q1 is configured to provide a fixed 3.3V, 5V or 12V output, or an adjustable output between 0.8V and 60V. This easy-to-use controller integrates high-side and low-side MOSFET gate drivers, each capable of sourcing 2A and sinking 3A peak current. Adaptive dead-time control is designed to minimize body diode conduction during switching transitions.

Peak current-mode control using a shunt resistor or inductor DCR current sensing provides inherent line feed forward, cycle-by-cycle peak current limiting, and easy loop compensation. Current-mode control also supports a wide duty cycle range for high input voltage and low-dropout applications as well as when a high voltage conversion ratio (for example, 10-to-1) is required. The oscillator frequency is user-programmable between 100kHz to 2.2MHz, and the frequency can be synchronized as high as 2.5MHz by applying an external clock to PFM/SYNC. A user-selectable PFM mode feature enables discontinuous conduction mode (DCM) operation to further improve efficiency and reduce power dissipation during light-load conditions.

The LM5137-Q1 incorporates features to simplify the compliance with automotive EMI requirements (CISPR 25). An optional spread spectrum frequency modulation (DRSS) technique reduces the peak EMI signature, while the adaptive gate drivers minimize high-frequency emissions. Finally, 180° out-of-phase interleaved operation of the two controller channels reduces input filtering and capacitor requirements.

The LM5137-Q1 is provided in a 36-pin VQFN package with a wettable flank pinout and an exposed pad to aid in thermal dissipation.

7.2 Functional Block Diagram

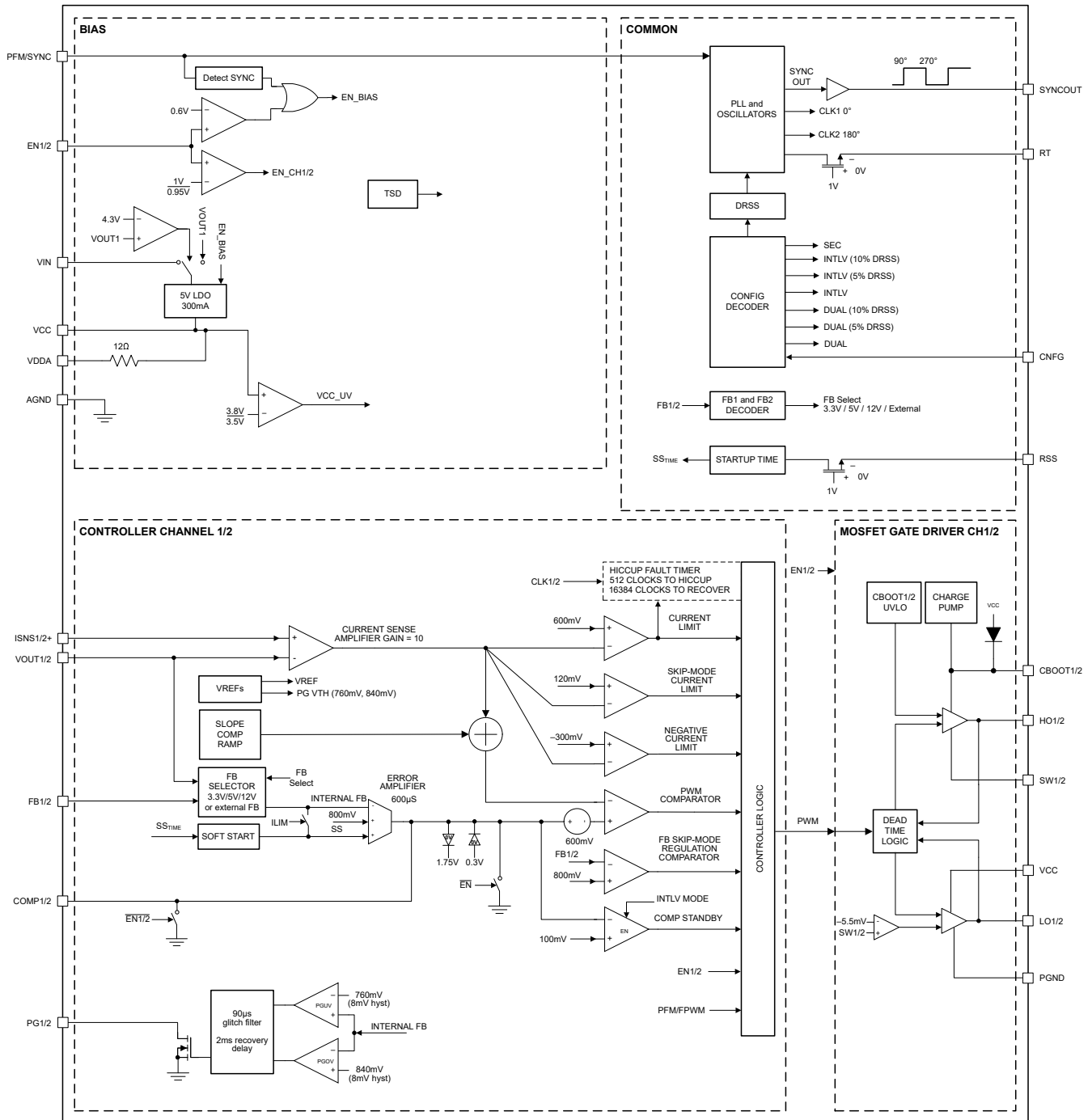

7.3 Feature Description

7.3.1 Input Voltage Range (V_{IN})

The LM5137-Q1 input voltage operating range is from 4V to 80V. The device is intended for step-down conversions from 12V, 24V and 48V automotive supply rails. The circuit in Figure 7-1 shows the essential components to implement an LM5137-Q1 based wide- V_{IN} dual-output buck regulator using a single input supply.

The LM5137-Q1 uses an internal LDO subregulator to provide a 5V VCC bias rail for the gate drive and control circuits (assuming the input voltage is higher than 5V plus the necessary subregulator dropout specification). There is also an integrated 20 μ A charge pump always active in LM5137-Q1. As V_{IN} approaches the V_{OUT} setpoint, the 20 μ A charge pump charges the C_{BOOT} and keeps the high-side MOSFET on, thus achieving true 100% duty cycle. This action allows for the lowest possible dropout voltage from input to output.

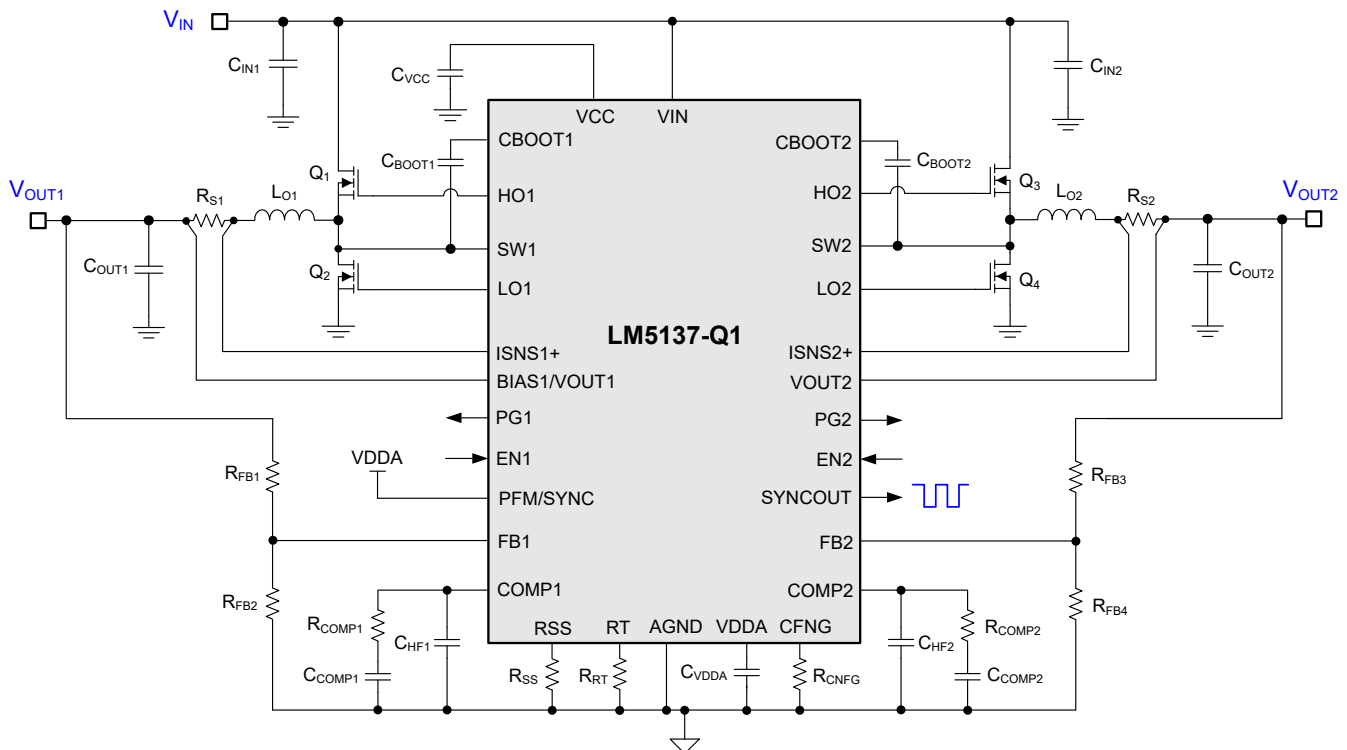

Figure 7-1. LM5137-Q1 Dual-Output Regulator Schematic

In high input voltage applications, make sure that the V_{IN} , SW1, and SW2 pin voltages do not exceed the absolute maximum voltage rating of 85V during line or load transient events. Voltage excursions that exceed the [Absolute Maximum Ratings](#) can damage the IC. Proceed carefully during PCB board layout and use high-quality input bypass capacitors to minimize switch-voltage overshoot and ringing.

7.3.2 Bias Supply Regulator (V_{CC} , $BIAS1/V_{OUT1}$, V_{DDA})

The LM5137-Q1 contains an internal high-voltage VCC bias regulator that provides the bias supply for the PWM controller and the gate drivers of the external MOSFETs. Connect the input voltage pin (V_{IN}) directly to an input voltage source up to 80V. When the input voltage is below the VCC setpoint of 5V, the VCC voltage tracks V_{IN} minus a small voltage drop.

The VCC regulator current limit is 175mA (minimum). At power up, the regulator sources current into the VCC capacitor. When the VCC voltage exceeds 3.8V (typical), both output channels are enabled (if EN1 and EN2 are above 1V) and the soft-start sequence begins. Both channels remain active unless the VCC voltage falls below the falling UVLO threshold of 3.5V (typical) or EN is switched to a low state. Connect a 2.2 μ F to 10 μ F ceramic capacitor from VCC to PGND.

A 12Ω internal resistor connects VDDA to VCC. Bypass VDDA to AGND with a 1μF ceramic capacitor to achieve a low-noise internal bias rail.

If the BIAS1/VOUT1 voltage is above 4.3V, BIAS1/VOUT1 internally connects to a second input of the VCC regulator. This action helps to reduce the internal power dissipation of the LM5137-Q1, as bias current derives from VOUT1 instead of VIN. Avoid connecting BIAS1/VOUT1 or VOUT2 to a voltage greater than 60V or less than -0.3V.

7.3.3 Precision Enable (EN1, EN2)

The LM5137-Q1 has a precision enable circuit on each EN input. When the EN1 or EN2 voltage is greater than 1V, switching is enabled on the respective channel. If EN1 and EN2 are pulled below 0.5V, the LM5137-Q1 is in shutdown with an I_Q of 3.6μA (typical) current consumption from V_{IN}. When the EN1 or EN2 voltage is between 0.6V and 1V, the LM5137-Q1 is in standby mode with the VCC regulator active but the controller is not switching. The input quiescent current in standby mode is 260μA typical.

Enable the LM5137-Q1 with a EN1/2 voltage greater than 1V. However, many applications benefit from using a resistor divider R_{UV1} and R_{UV2}, as shown in Figure 7-2, to establish a precision UVLO level. Add R_{UV3} in series to provide additional voltage hysteresis. Avoid leaving the EN1 and EN2 pins floating. Keep the EN1/2 voltage under 80V.

Use Equation 1 to calculate the UVLO resistors, where V_{IN(on)} and V_{IN(off)} are the required input voltage turn-on and turn-off thresholds.

$$R_{UV2} = \left[\frac{V_{EN(off)} - (V_{IN(off)} / V_{IN(on)}) \cdot V_{EN(on)}}{I_{EN(hys)}} - R_{UV3} \right] \cdot \frac{V_{IN(on)}}{V_{IN(on)} - V_{EN(on)}}$$

$$R_{UV1} = R_{UV2} \cdot \left(\frac{V_{IN(on)}}{V_{EN(on)}} - 1 \right) \tag{1}$$

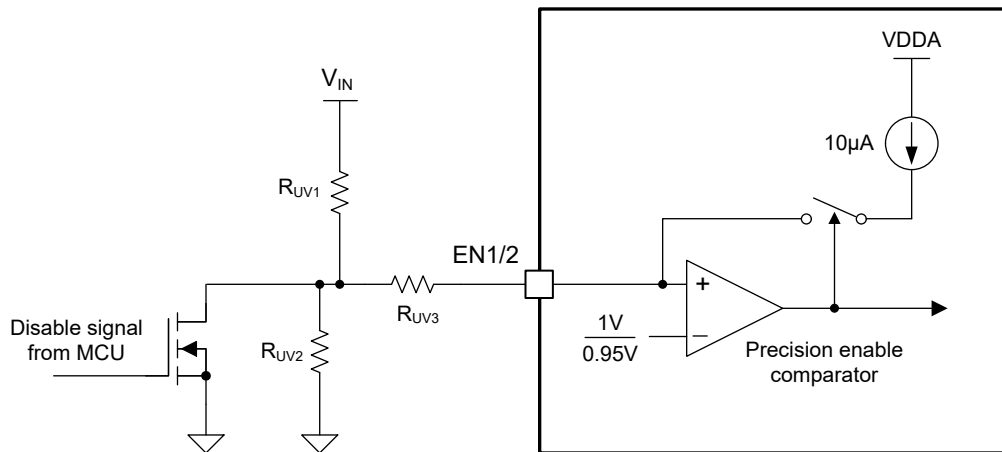

Figure 7-2. Programmable Input Voltage UVLO Turn-On, Turn-Off

7.3.4 Switching Frequency (RT)

Program the LM5137-Q1 oscillator with a resistor from RT to AGND to set the free-running switching frequency between 100kHz and 2.2MHz. Use Equation 2 to calculate the RT resistance for a given switching frequency.

$$R_{RT} [k\Omega] = \frac{10^6}{F_{SW} [kHz]} - 15 \quad (2)$$

7.3.5 Pulse Frequency Modulation and Synchronization (PFM/SYNC)

A synchronous buck regulator implemented with a low-side MOSFET rather than a diode has the capability to sink negative current from the output during light load, output overvoltage, and prebias start-up conditions. The LM5137-Q1 provides a diode emulation feature that can be enabled to prevent reverse (drain-to-source) current flow in the low-side MOSFET. When configured for diode emulation mode, the low-side MOSFET is switched off when reverse current flow is detected by sensing the SW voltage using a zero-cross comparator. The benefit of this configuration is lower power loss during light-load conditions. The disadvantage of diode emulation mode is slower light-load transient response.

Use the PFM/SYNC pin to configure diode emulation. To enable diode emulation and thus achieve high efficiency at light loads, connect PFM/SYNC to VDDA. If FPWM with continuous conduction mode (CCM) operation is preferred, tie PFM/SYNC to AGND. Note that diode emulation is automatically engaged to prevent reverse current flow during a prebiased start-up. A gradual change from DCM to CCM operation provides monotonic start-up performance.

To synchronize the LM5137-Q1 to an external clock source, apply a logic-level signal to PFM/SYNC. The LM5137-Q1 is synchronizable to $\pm 20\%$ of the programmed free-running frequency up to a maximum of 2.5MHz. If there is an RT resistor and a synchronization clock signal, the LM5137-Q1 ignores the RT resistor and synchronizes to the external clock. However, when the minimum off-time is reached at high duty cycle, the synchronization is ignored, allowing reduction of the switching frequency to maintain output voltage regulation.

7.3.6 Synchronization Out (SYNCOUT)

The SYNCOUT voltage is a logic-level signal with a rising edge approximately 90° lagging HO2 (or 90° leading HO1). When the SYNCOUT signal is used to synchronize a second LM5137-Q1 controller, all four phases are 90° out of phase, thus optimizing ripple current cancellation.

7.3.7 Dual Random Spread Spectrum (DRSS)

The LM5137-Q1 provides a digital spread spectrum, which reduces the EMI signature of the switching regulator over a wide frequency range. As shown in [Figure 7-3](#), DRSS combines a low-frequency triangular modulation profile with a high frequency cycle-by-cycle random modulation profile. The low-frequency modulation improves performance in lower radio-frequency bands, while the high-frequency random modulation improves performance in higher radio-frequency bands.

Spread spectrum functions by converting a narrowband signal into a wideband signal that spreads the energy over multiple frequencies. Because industry standards require different EMI receiver resolution bandwidth (RBW) settings for different frequency bands, the RBW has an impact on the spread spectrum performance. For example, the RBW setting in an EMI receiver for CISPR 25 in the frequency band from 150kHz to 30MHz is 9kHz. For frequencies greater than 30MHz, the RBW is 120kHz. DRSS is able to simultaneously improve the EMI performance with low and high RBWs with the low-frequency triangular and high-frequency cycle-by-cycle random modulation profiles, respectively. DRSS can reduce conducted emissions by 10dB μ V in the CISPR 25 low-frequency band (150kHz to 30MHz) and 5dB μ V in the high-frequency band (30MHz to 108MHz). Applying an external clock signal to PFM/SYNC disables DRSS. See [Table 7-1](#) to configure the LM5137-Q1 using a resistor from CNFG to AGND.

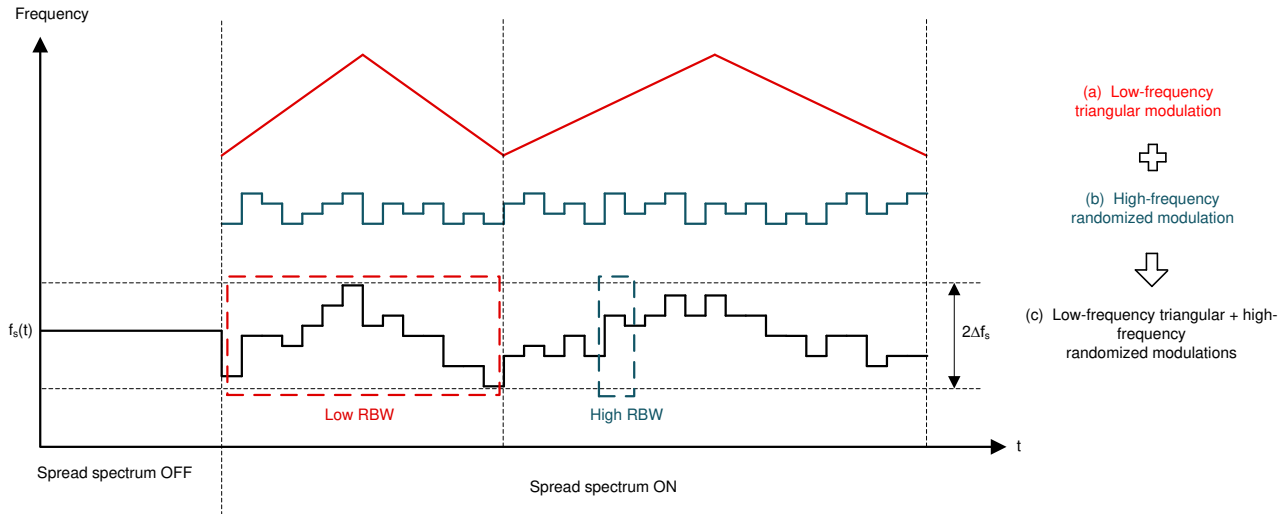

Figure 7-3. DRSS Implementation

Table 7-1. CNFG Resistor Configuration

R _{CNFG}	PRIMARY / SECONDARY	DRSS	INDEPENDENT OR INTERLEAVED
10kΩ	Primary	Disabled	Independent
19.1kΩ	Primary	±5%	Independent
29.4kΩ	Primary	±10%	Independent
41.2kΩ	Primary	Disabled	Interleaved
54.9kΩ	Primary	±5%	Interleaved
71.5kΩ	Primary	±10%	Interleaved
90.9kΩ	Secondary	N/A	Interleaved

7.3.8 Configurable Soft Start (RSS)

The soft-start feature of the LM5137-Q1 allows the regulator to gradually reach the steady-state operating point, thus reducing start-up stresses and inrush current. Program the soft-start time with a resistor from RSS to AGND. If the RSS pin is shorted to AGND, the soft-start time is 1.5ms. If the RSS resistance is greater than 500kΩ (or the pin is left open circuit), the LM5137-Q1 defaults to a soft-start time of 6.5ms.

Use Equation 3 to calculate the RSS resistance for a given soft-start time.

$$R_{SS} [k\Omega] = 4.38 \cdot t_{SS} [ms] \quad (3)$$

7.3.9 Output Voltage Setpoints (FB1, FB2)

The LM5137-Q1 can be independently configured for one of the three fixed output voltage setpoints or adjusted to the desired output voltage using an external resistor divider. As shown in Table 7-2, configure V_{OUT1} or V_{OUT2} for a 3.3V, 5V, or 12V voltage setpoint by connecting the respective FB pin with a 7.5kΩ, 24.9kΩ, or 48.7kΩ to VDDA, respectively.

Table 7-2. Feedback Configuration Resistor

PULLUP RESISTOR TO VDDA	V _{OUT} SETPOINT
7.5kΩ	3.3V
24.9kΩ	5V
48.7kΩ	12V
Not installed	External FB divider setting

The configuration settings are latched and cannot be changed until the LM5137-Q1 is powered down with the VCC voltage decreasing below the falling UVLO threshold, and then powered up again with VCC above 3.8V.

Alternatively, set the output voltage with an external resistor divider from the output to AGND. The FB regulation voltage is 0.8V, and the output voltage setpoint range is from 0.8V to 60V. Use Equation 4 to calculate the upper and lower feedback resistors, designated R_{FB1} and R_{FB2} , respectively. See Figure 7-4.

$$R_{FB1} = \left(\frac{V_{OUT}}{V_{REF}} - 1 \right) \cdot R_{FB2} \quad (4)$$

A recommended starting value for R_{FB2} is between 10k Ω and 20k Ω .

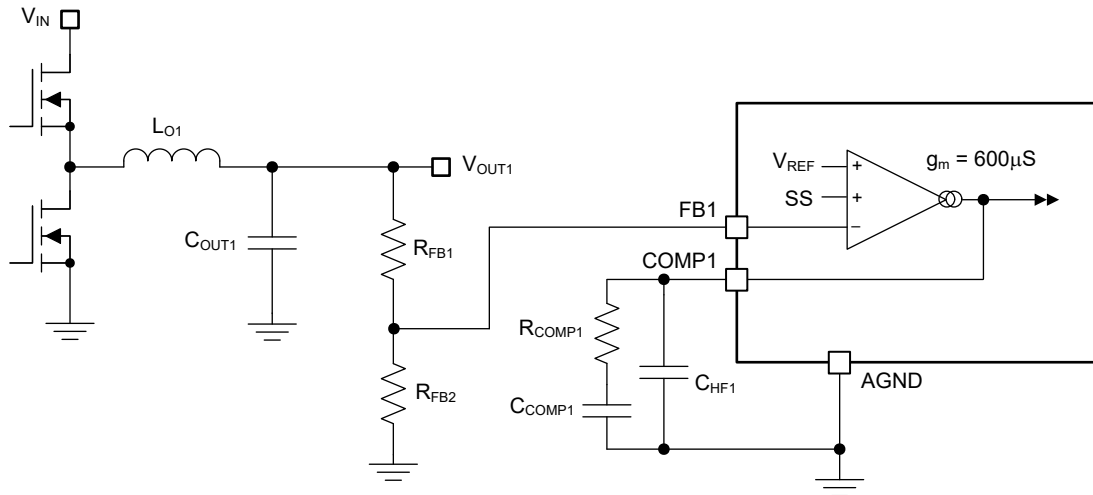

Figure 7-4. Voltage Loop With Adjustable Output Setting

If high light-load efficiency is required, take care when selecting the external resistors. The current consumption of the external divider adds to the LM5137-Q1 sleep current. The divider current reflected to V_{IN} scales by the ratio of V_{OUT}/V_{IN} .

7.3.10 Error Amplifier and PWM Comparator (FB1, FB2, COMP1, COMP2)

Each channel of the LM5137-Q1 has an independent high-gain transconductance amplifier that generates an error current proportional to the difference between the feedback voltage and an internal precision reference (0.8V). The output of the transconductance amplifier connects to the respective COMP pin, allowing the user to provide external control loop compensation. TI generally recommends a type-II compensation network for peak current-mode control. The HO1/2 and LO1/2 driver outputs can be disabled if COMP1/2 is pulled below 100mV.

7.3.10.1 Slope Compensation

The LM5137-Q1 provides internal slope compensation for stable operation with peak current-mode control and a duty cycle greater than 50%. Use Equation 5 to calculate the buck inductance to provide a slope compensation contribution equal to one times the inductor current downslope.

$$L_{O(IDEAL)} [\mu H] = \frac{V_{OUT} [V] \cdot R_S [m\Omega]}{22 \cdot F_{SW} [MHz]} \quad (5)$$

- A lower inductance value generally increases the peak-to-peak inductor ripple current, which minimizes size and cost, and improves transient response at the cost of reduced light-load efficiency due to higher cores losses and peak currents.
- A higher inductance value generally decreases the peak-to-peak inductor ripple current, reducing switch peak and RMS currents at the cost of requiring larger output capacitors to meet load-transient specifications.

7.3.11 Inductor Current Sense (ISNS1+, BIAS1/VOUT1, ISNS2+, VOUT2)

There are two methods to sense the inductor current of the buck power stage. The first uses a current sense resistor (also known as a shunt) in series with the inductor, and the second avails of the DC resistance of the inductor (DCR current sensing).

7.3.11.1 Shunt Current Sensing

Figure 7-5 illustrates inductor current sensing using a shunt resistor. This configuration continuously monitors the inductor current to provide accurate overcurrent protection across the operating temperature range. For optimal current sense accuracy and overcurrent protection, use a *low parasitic inductance* shunt resistor of $\pm 1\%$ tolerance connected between the inductor and the output. Use Kelvin sense connections at the shunt and route the sense lines differentially back to the LM5137-Q1.

If the peak voltage sensed differentially at [ISNS1+, BIAS1/VOUT1] or [ISNS2+, VOUT2] exceeds the current limit threshold of 60mV, the current limit comparator immediately terminates the respective HO output for cycle-by-cycle current limiting. Calculate the shunt resistance using Equation 6.

$$R_S = \frac{V_{CS-TH}}{I_{OUT(CL)} + \frac{\Delta I_L}{2}} \quad (6)$$

where

- V_{CS-TH} is current sense threshold of 60mV.
- $I_{OUT(CL)}$ is the overcurrent setpoint that is set higher than the maximum load current to avoid tripping the overcurrent comparator during load transients.
- ΔI_L is the peak-to-peak inductor ripple current.

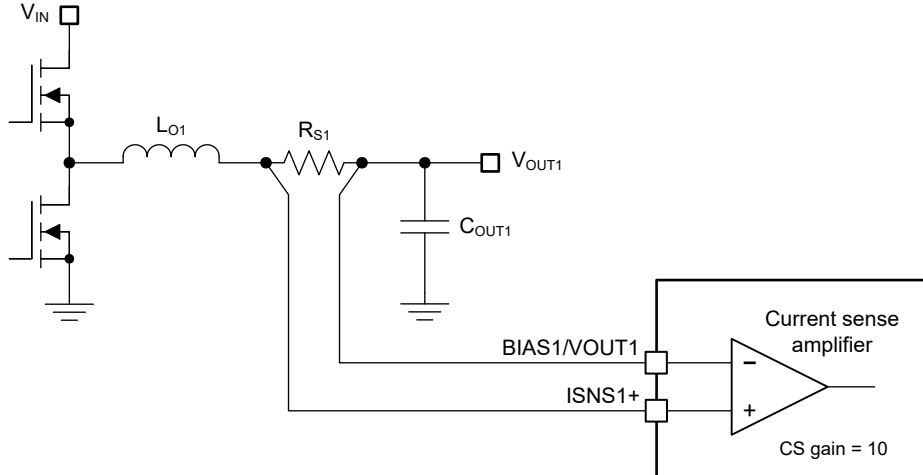

Figure 7-5. Shunt Current Sensing Implementation

7.3.11.2 Inductor DCR Current Sensing

For high-power applications that do not require accurate current-limit protection, inductor DCR current sensing is preferable. This technique provides lossless and continuous monitoring of the inductor current using an RC sense network in parallel with the inductor. Select an inductor with a low DCR tolerance to achieve a typical current limit accuracy within the range of 10% to 15% at room temperature. Components R_{CS} and C_{CS} in Figure 7-6 create a low-pass filter across the inductor to enable differential sensing of the voltage drop across the inductor DCR.

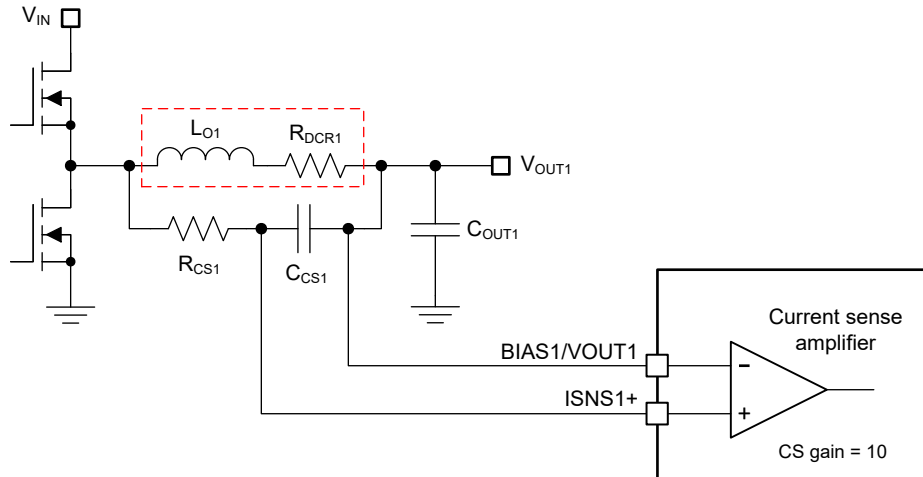

Figure 7-6. Inductor DCR Current Sensing Implementation

Use [Equation 7](#) to calculate the voltage drop across the sense capacitor in the s-domain. When the $R_{CS}C_{CS}$ time constant is equal to L_O/R_{DCR} , the voltage developed across the sense capacitor, C_{CS} , is a replica of the inductor DCR voltage and accurate current sensing is achieved. If the $R_{CS}C_{CS}$ time constant is not equal to the L_O/R_{DCR} time constant, there is a sensing error as follows:

- $R_{CS}C_{CS} > L_O/R_{DCR} \rightarrow$ the DC level is correct, but the AC amplitude is attenuated.
- $R_{CS}C_{CS} < L_O/R_{DCR} \rightarrow$ the DC level is correct, but the AC amplitude is amplified.

$$V_{CS}(s) = \frac{1 + s \cdot \frac{L_O}{R_{DCR}}}{1 + s \cdot R_{CS} \cdot C_{CS}} \cdot R_{DCR} \cdot \left(I_{OUT(CL)} + \frac{\Delta I_L}{2} \right) \quad (7)$$

Choose the C_{CS} capacitance greater than or equal to 100nF to maintain a low-impedance sensing network, thus reducing the susceptibility of noise pickup from the switch node. Carefully observe [Section 8.4.1](#) to make sure that noise and DC errors do not corrupt the differential current sense signals applied between the respective ISNS1/2+ and VOUT1/2 pins.

7.3.12 Minimum Controllable On-Time

There are two limitations to the minimum output voltage adjustment range: the LM5137-Q1 voltage reference of 0.8V and the minimum controllable switch-node pulse width, $t_{ON(min)}$.

$t_{ON(min)}$ effectively limits the voltage step-down conversion ratio of V_{OUT}/V_{IN} at a given switching frequency. For fixed-frequency PWM operation, the voltage conversion ratio must satisfy [Equation 8](#).

$$\frac{V_{OUT}}{V_{IN}} > t_{ON(min)} \cdot F_{SW} \quad (8)$$

where

- $t_{ON(min)}$ is 22ns (typical)
- F_{SW} is the switching frequency

If the desired voltage conversion ratio does not meet the above condition, the LM5137-Q1 transitions from fixed switching frequency operation to a pulse-skipping mode to maintain output voltage regulation. For example, if the desired output voltage is 1.2V with an input voltage is 24V and switching frequency of 2.1MHz, the voltage conversion ratio test in [Equation 9](#) is satisfied.

$$\frac{1.2\text{V}}{24\text{V}} > 22\text{ns} \cdot 2.1\text{MHz}$$

$$0.05 > 0.046$$

(9)

For wide V_{IN} applications and low output voltages, an alternative is to reduce the LM5137-Q1 switching frequency to meet the requirement of [Equation 8](#).

7.3.13 100% Duty Cycle Capability

An integrated 20 μ A charge pump is always active in the LM5137-Q1. As V_{IN} approaches the V_{OUT} setpoint, the duty cycle extends towards 100%. When the control loop attempts to set an off-time less than $t_{OFF(min)}$, the LM5137-Q1 skips the off-time interval for that particular switching cycle and enters 100% duty cycle mode. Under these conditions, C_{BOOT} cannot charge by the usual path from VCC through the bootstrap diode, since the low-side MOSFET is not turned on. Instead, the 20 μ A charge pump charges C_{BOOT} and keeps the high-side MOSFET on, thus achieving true 100% duty cycle – at least until the control loop again demands an off-time greater than $t_{OFF(min)}$. This action allows for the lowest possible dropout voltage from input to output. Note that adding a gate-to-source resistor at the high-side MOSFET can discharge C_{BOOT} and thus affect 100% duty-cycle operation.

7.3.14 MOSFET Gate Drivers (HO1, HO2, LO1, LO2)

The LM5137-Q1 contains MOSFET gate drivers and associated high-side level shifters to drive the external N-channel power MOSFETs. The high-side gate driver works in conjunction with the integrated bootstrap diode and external bootstrap capacitor C_{BOOT} . During the conduction interval of the low-side MOSFET, the SW voltage is approximately 0V and C_{BOOT} charges from VCC through the diode.

The LM5137-Q1 controls the HO and LO outputs with an adaptive dead-time methodology such that both outputs (HO and LO) are never enabled at the same time, preventing cross conduction. When the controller commands LO to be enabled, the adaptive dead-time logic first disables HO and waits for the HO-to-GND voltage to drop below 2V (typical). LO is then enabled after a small delay (HO falling to LO rising delay). Similarly, the HO turn-on is delayed until the LO voltage has dropped below 2V. HO is then enabled after a small delay (LO falling to HO rising delay). This technique provides adequate dead-time for any size N-channel MOSFET component or parallel MOSFET configurations. Caution is advised when adding series gate resistors, as series gate resistors can decrease the effective dead-time. The selected high-side power MOSFET determines the appropriate bootstrap capacitance value C_{BOOT} in accordance with [Equation 10](#).

$$C_{BOOT} = \frac{Q_G}{\Delta V_{CBOOT}} \quad (10)$$

where

- Q_G is the total gate charge of the high-side MOSFET at the applicable gate drive voltage, normally 5V
- ΔV_{CBOOT} is the voltage variation of the high-side MOSFET driver after turn-on

To determine C_{BOOT} , choose ΔV_{CBOOT} so that the available gate drive voltage is not significantly impacted. An acceptable range of ΔV_{CBOOT} is 100mV to 200mV. The bootstrap capacitor must be a low-ESR ceramic capacitor, typically 0.1 μ F. Given the nominal VCC voltage of 5V, it is imperative to use **logic-level** power MOSFETs with $R_{DS(on)}$ rated at $V_{GS} = 4.5\text{V}$.

7.3.15 Output Configurations (CNFG)

Using a resistor designated as R_{CNFG} connected from CNFG to AGND, configure the LM5137-Q1 as a primary controller (independent dual outputs or interleaved single output) or as a secondary controller for paralleled phases in high-current applications.

7.3.15.1 Independent Dual-Output Operation

The LM5137-Q1 has two outputs that can operate independently. Both V_{OUT1} and V_{OUT2} can be set to fixed output setpoints of 3.3V, 5V, or 12V using one resistor from VDDA to FB1 or FB2 as needed. Alternatively, set the output voltage setpoints between 0.8V and 60V using external feedback resistors based on Equation 4. See Table 7-3 and Figure 7-7.

Table 7-3. Configuration Modes for Independent Dual Outputs

R_{CNFG}	PRIMARY, SECONDARY	DRSS	INDEPENDENT OR INTERLEAVED OUTPUTS
10k Ω	Primary	OFF	Independent
19.1k Ω	Primary	DRSS1	Independent
29.4k Ω	Primary	DRSS2	Independent

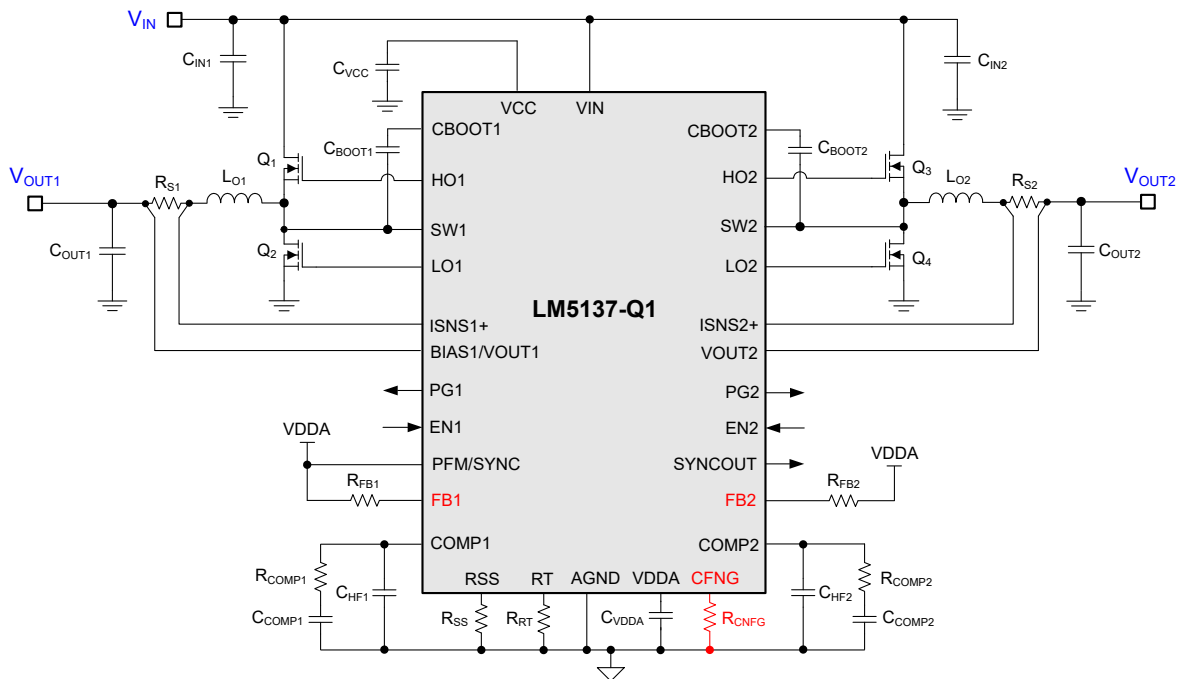

Figure 7-7. LM5137-Q1 Regulator Schematic Configured for Independent Dual Outputs

7.3.15.2 Single-Output Interleaved Operation

Based on a resistor R_{CNFG} connected from CNFG to AGND, configure the LM5137-Q1 as for single-output interleaved operation. As shown in Table 7-4, use 41.2k Ω to disable DRSS and 54.9k Ω or 71.5k Ω to enable DRSS at 5% or 10% frequency spreading, respectively. This setup disables the error amplifier of channel 2 and places the error amplifier in a high impedance state. The controller is then in a primary, secondary configuration, and the SYNCOUT clock is 180° lagging HO2 (or 180° leading HO1).

As shown in Figure 7-8, connect COMP1 to COMP2 and use FB1 to set the output voltage setpoint. Use PG1 as needed and leave PG2 open or tied to GND.

Table 7-4. Configuration Modes for Single-Output Interleaved Operation

R_{CNFG}	PRIMARY / SECONDARY	DRSS	INDEPENDENT OR INTERLEAVED OUTPUTS
41.2k Ω	Primary	OFF	Interleaved
54.9k Ω	Primary	DRSS1	Interleaved
71.5k Ω	Primary	DRSS2	Interleaved

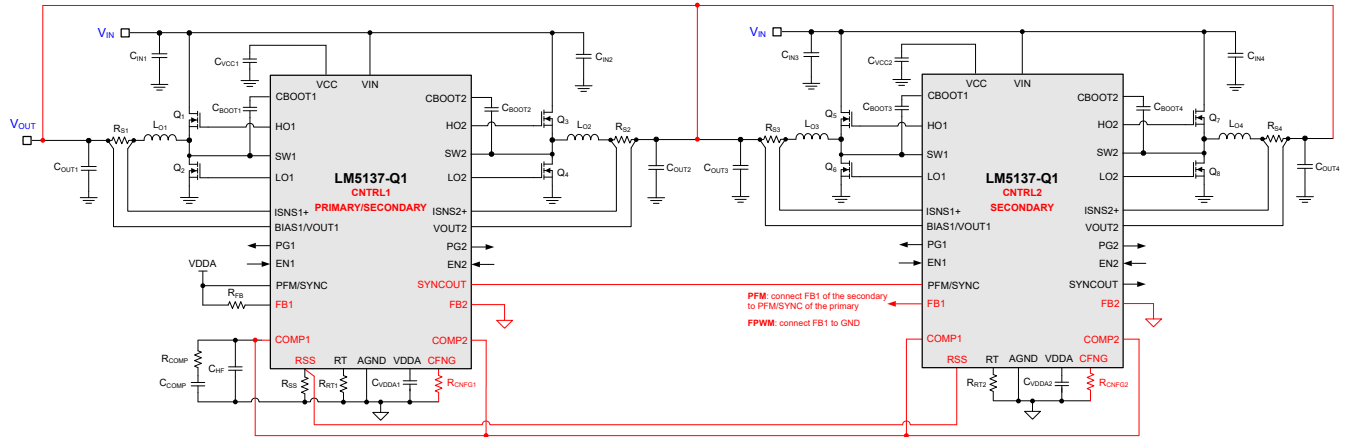

Figure 7-9. LM5137-Q1 Multiphase Regulator Schematic Configured for Single-Output Interleaved Operation

7.4 Device Functional Modes

7.4.1 Sleep Mode

The LM5137-Q1 operates with peak current-mode control such that the compensation (COMP) voltage is proportional to the peak inductor current. During no-load or light-load conditions, the output capacitor discharges very slowly. As a result, the COMP voltage does not demand the driver output pulses on a cycle-by-cycle basis. When the LM5137-Q1 controller detects 16 missed switching cycles, the device enters sleep mode and switches to a low I_Q state to reduce the current drawn from the input. For the LM5137-Q1 to go into sleep mode, the device must be programmed for diode emulation (tie PFM/SYNC to VDDA).

The typical controller I_Q in sleep mode at 12V input is 1.5 μ A with channels 1 and 2 set to 5V and 3.3V outputs, respectively. PG1/2 are disabled when the LM5137-Q1 goes to sleep.

7.4.2 PFM Mode

A synchronous buck regulator implemented with a low-side MOSFET rather than a diode has the capability to sink negative current from the output during light-load, overvoltage, and prebias start-up conditions. The LM5137-Q1 provides a diode emulation feature that can be enabled to prevent reverse (drain-to-source) current flow in the low-side MOSFET. When configured for diode emulation (DEM), the low-side MOSFET is switched off when reverse current flow is detected by sensing of the applicable SW voltage using a zero-cross comparator. The benefit of this configuration is lower power loss during light-load conditions; the disadvantage being slower light-load transient response.

Table 7-6. PFM Settings

PFM/SYNC	FPWM, PFM
VDDA	PFM
AGND	FPWM
External clock	FPWM

Configure the diode emulation feature using the PFM/SYNC pin. To enable diode emulation and thus achieve discontinuous conduction mode (DCM) operation at light loads, connect PFM/SYNC to VDDA. If FPWM or continuous conduction mode (CCM) operation is desired, tie PFM/SYNC to AGND. See [Table 7-6](#). Note that diode emulation is automatically engaged (in both PFM and FPWM modes) to prevent reverse current flow during a prebias start-up. A gradual change from DCM to CCM operation provides monotonic start-up performance.

8 Application and Implementation

Note

Information in the following applications sections is not part of the TI component specification, and TI does not warrant its accuracy or completeness. TI's customers are responsible for determining suitability of components for their purposes, as well as validating and testing their design implementation to confirm system functionality.

8.1 Application Information

The LM5137-Q1 is a dual-channel or dual-phase, synchronous, buck controller used to convert a higher input voltage to one or two lower output voltages. The following sections consider the power-train and compensation components and provide specific circuit design examples for single- and dual-output implementations. To expedite and streamline the process of designing of an LM5137-Q1-based regulator, a comprehensive LM5137-Q1 [Quickstart Calculator](#) is available for download to assist the designer with component selection for a given application.

8.1.1 Power Train Components

A comprehensive understanding of the buck regulator power train components is critical to successfully completing an efficient and reliable synchronous buck regulator design. The following sections discuss the following:

- Power MOSFETs
- Buck inductor
- Input and output capacitors
- EMI input filter

8.1.1.1 Power MOSFETs

The choice of power MOSFETs has an outsized impact on DC/DC regulator performance. A MOSFET with low on-state resistance, $R_{DS(on)}$, reduces conduction loss, whereas low parasitic capacitances enable faster transition times and reduced switching loss. Normally, the lower the $R_{DS(on)}$ of a MOSFET, the higher the gate charge and output charge (Q_G and Q_{OSS} , respectively), and vice-versa. As a result, the product of $R_{DS(on)}$ and Q_G is commonly specified as a MOSFET figure-of-merit. Low thermal resistance of a given package makes sure that the MOSFET power dissipation does not result in excessive MOSFET die temperature.

The main parameters affecting power MOSFET selection in an LM5137-Q1 application are as follows:

- $R_{DS(on)}$ at $V_{GS} = 5V$
- Drain-source voltage rating, BV_{DSS} , is typically 40V, 60V or 80V, depending on the maximum input voltage.
- Gate charge parameters at $V_{GS} = 5V$
- Output charge, Q_{OSS} , at the relevant input voltage
- Body diode reverse recovery charge, Q_{RR}
- Gate threshold voltage, $V_{GS(th)}$, derived from the Miller plateau evident in the Q_G versus V_{GS} plot in the MOSFET data sheet. With a Miller plateau voltage typically in the range of 2.5V to 3.2V, the 5V gate drive amplitude of the LM5137-Q1 provides an adequately-enhanced MOSFET when on and a margin against Cdv/dt shoot-through when off.

The MOSFET-related power losses for one channel are summarized by the equations presented in [Table 8-1](#), where suffixes 1 and 2 represent high-side and low-side MOSFET parameters, respectively. While the influence of inductor ripple current is considered, second-order loss modes, such as those related to parasitic inductances and switch-node voltage ringing, are not included. A comprehensive [Quickstart Calculator](#) available from the LM5137-Q1 product folder provides power loss calculations based on the entered MOSFET parameters, including $R_{DS(on)}$ and Q_G .

Table 8-1. MOSFET Power Losses

POWER LOSS MODE	HIGH-SIDE MOSFET	LOW-SIDE MOSFET
MOSFET conduction ⁽²⁾ ⁽³⁾	$P_{\text{cond1}} = D \cdot \left(I_{\text{OUT}}^2 + \frac{\Delta I_L^2}{12} \right) \cdot R_{\text{DS(on)1}}$	$P_{\text{cond2}} = D' \cdot \left(I_{\text{OUT}}^2 + \frac{\Delta I_L^2}{12} \right) \cdot R_{\text{DS(on)2}}$
MOSFET switching	$P_{\text{sw1}} = \frac{V_{\text{IN}} \cdot F_{\text{SW}}}{2} \left[\left(I_{\text{OUT}} - \frac{\Delta I_L}{2} \right) \cdot t_{\text{r}} + \left(I_{\text{OUT}} + \frac{\Delta I_L}{2} \right) \cdot t_{\text{f}} \right]$	Negligible
MOSFET gate drive ⁽¹⁾	$P_{\text{Gate1}} = V_{\text{CC}} \cdot F_{\text{SW}} \cdot Q_{\text{G1}}$	$P_{\text{Gate2}} = V_{\text{CC}} \cdot F_{\text{SW}} \cdot Q_{\text{G2}}$
MOSFET output charge ⁽⁴⁾	$P_{\text{Coss}} = F_{\text{SW}} \cdot (V_{\text{IN}} \cdot Q_{\text{oss2}} + E_{\text{oss1}} - E_{\text{oss2}})$	
Body diode conduction	N/A	$P_{\text{condbd}} = V_{\text{F}} \cdot F_{\text{SW}} \left[\left(I_{\text{OUT}} + \frac{\Delta I_L}{2} \right) \cdot t_{\text{dt1}} + \left(I_{\text{OUT}} - \frac{\Delta I_L}{2} \right) \cdot t_{\text{dt2}} \right]$
Body diode reverse recovery ⁽⁵⁾	$P_{\text{RR}} = V_{\text{IN}} \cdot F_{\text{SW}} \cdot Q_{\text{RR2}}$	

- (1) Gate drive loss is apportioned based on the internal gate resistance of the MOSFET, externally added series gate resistance, and the relevant driver resistance of the LM5137-Q1.
- (2) MOSFET $R_{\text{DS(on)}}$ has a positive temperature coefficient of approximately 4500ppm/°C. The MOSFET junction temperature, T_{J} , and the rise over ambient temperature is dependent upon the device total power dissipation and the thermal impedance. When operating at or near minimum input voltage, make sure that the MOSFET $R_{\text{DS(on)}}$ is rated for the available gate drive voltage.
- (3) $D' = 1 - D$ is the duty cycle complement.
- (4) MOSFET output capacitances, C_{oss1} and C_{oss2} , are highly non-linear with voltage. These capacitances are charged losslessly by the inductor current at high-side MOSFET turnoff. During turn-on, however, a current flows from the input to charge the output capacitance of the low-side MOSFET. E_{oss1} , the energy of C_{oss1} , is dissipated at turn-on, but this dissipation is offset by the stored energy E_{oss2} on C_{oss2} . For more detail, see also [Comparison of deadtime effects on the performance of DC-DC converters with GaN FETs and silicon MOSFETs](#), ECCE 2016.
- (5) MOSFET body diode reverse recovery charge, Q_{RR} , depends on many parameters, particularly forward current, current transition speed, and temperature.

The high-side (control) MOSFET carries the inductor current during the PWM on-time (or D interval) and typically incurs most of the switching losses, so make sure to choose a high-side MOSFET that balances conduction and switching loss contributions. The total power dissipation in the high-side MOSFET is the sum of the following:

- Losses due to conduction
- Switching (voltage-current overlap)
- Output charge
- Typically two-thirds of the net loss attributed to body diode reverse recovery

The low-side (synchronous) MOSFET carries the inductor current when the high-side MOSFET is off (or 1–D interval). The low-side MOSFET switching loss is negligible as is switched at zero voltage – current just communicates from the channel to the body diode or vice-versa during the transition dead times. The LM5137-Q1, with the adaptive gate drive timing, minimizes body diode conduction losses when both MOSFETs are off. Such losses scale directly with switching frequency.

In high step-down ratio applications, the low-side MOSFET carries the current for a large portion of the switching period. Therefore, to attain high efficiency, optimizing the low-side MOSFET for low $R_{\text{DS(on)}}$ is critical. In cases where the conduction loss is too high or the target $R_{\text{DS(on)}}$ is lower than available in a single MOSFET, connect two low-side MOSFETs in parallel. The total power dissipation of the low-side MOSFET is the sum of the losses due to channel conduction, body diode conduction, and typically one-third of the net loss attributed to body diode reverse recovery. The LM5137-Q1 is an excellent choice to drive TI's portfolio of [power MOSFETs](#).

8.1.1.2 Buck Inductor

For most applications, choose a buck inductance such that the inductor ripple current, ΔI_L , is between 30% and 50% of the maximum DC output current at nominal input voltage. Choose the inductance using [Equation 11](#) based on a peak inductor current given by [Equation 12](#).

$$L_O = \frac{V_{OUT}}{\Delta I_L \cdot F_{SW}} \cdot \left(1 - \frac{V_{OUT}}{V_{IN}} \right) \quad (11)$$

$$I_{L(\text{peak})} = I_{OUT} + \frac{\Delta I_L}{2} \quad (12)$$

Check the inductor data sheet to make sure that the saturation current rating is well above the peak inductor current of a particular design. Ferrite-cored inductors have very low core loss and are preferred at high switching frequencies, so design goals can then concentrate on copper loss and preventing saturation. Low inductor core loss is evidenced by reduced no-load input current and higher light-load efficiency. However, ferrite core materials exhibit a hard saturation characteristic where the inductance collapses abruptly when the saturation current is exceeded. This action results in an outsized increase in inductor ripple current and higher output voltage ripple, not to mention reduced efficiency and compromised reliability. Note that the saturation current rating of an inductor generally decreases as the core temperature increases. Of course, accurate overcurrent protection is critical to avoiding inductor saturation.

8.1.1.3 Output Capacitors

Ordinarily, the energy stored by the output capacitors combined with the control loop response prescribe to maintain the integrity of the output voltage within the dynamic (transient) tolerance specifications. The usual boundaries restricting the output capacitors in power management applications are driven by finite available PCB area, component footprint and profile, and cost. As the load step amplitude and slew rate increase, the capacitor parasitics – equivalent series resistance (ESR) and equivalent series inductance (ESL) – take greater precedence in shaping the load transient response of the regulator.

The output capacitor, C_{OUT} , filters the inductor ripple current and provides a reservoir of charge for step-load transient events. Typically, ceramic capacitors provide extremely low ESR to reduce the output voltage ripple and noise spikes, while tantalum and polymer electrolytic capacitors provide a large bulk capacitance in a relatively compact footprint for transient loading events.

Based on the static specification of peak-to-peak output voltage ripple denoted by ΔV_{OUT} , choose an output capacitance that is higher than that given by [Equation 13](#).

$$C_{OUT} \geq \frac{\Delta I_L}{8 \cdot F_{SW} \sqrt{\Delta V_{OUT}^2 - (R_{ESR} \cdot \Delta I_L)^2}} \quad (13)$$

[Figure 8-1](#) conceptually illustrates the relevant current waveforms during both load-on and load-off transitions. As shown, the slow rate of the inductor current represent a large-signal constraint as the inductor current ramps to match the new load-current level following a load transient. This slow-rate limiting exacerbates the deficit of charge in the output capacitor, which must be replenished as rapidly as possible during and after a load-on transient. Similarly, during and after a load-off transient, the slow rate limiting of the inductor current adds to the surplus of charge in the output capacitor that must be depleted as quickly as possible.

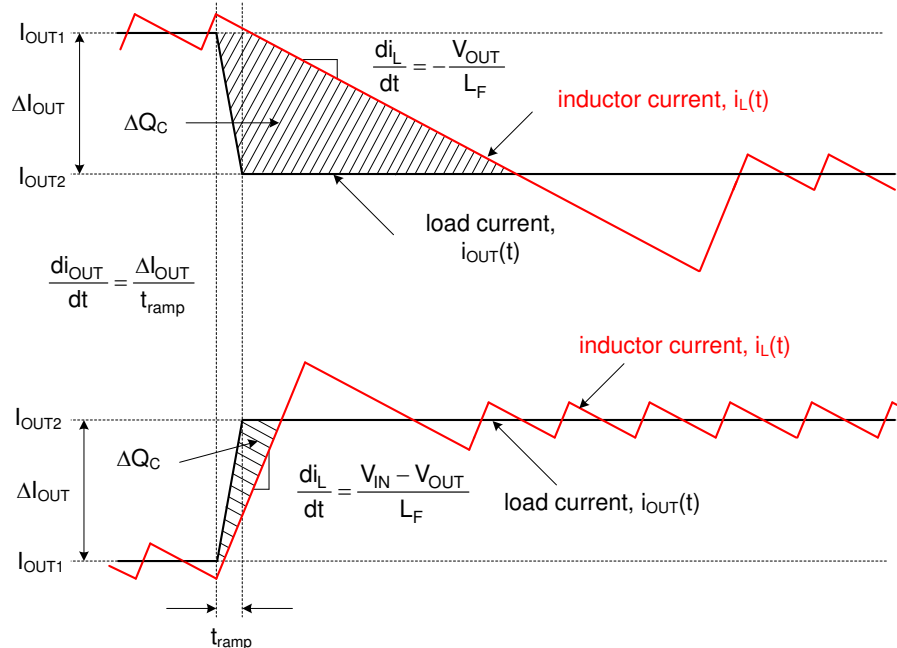

Figure 8-1. Load Transient Response Representation Showing C_{OUT} Charge Surplus or Deficit

In a typical regulator application of 48V input to low output voltage (for example, 12V), the load-off transient represents the worst case in terms of output voltage transient deviation. With that voltage conversion ratio, the steady-state duty cycle is approximately 25% and the large-signal inductor current slew rate when the duty cycle collapses to zero is approximately $-V_{OUT}/L$. Compared to a load-on transient, the inductor current takes much longer to transition to the required level. The surplus of charge in the output capacitor causes the output voltage to significantly overshoot. In fact, to deplete this excess charge from the output capacitor as quickly as possible, the inductor current must ramp below the nominal level following the load step. In this scenario, a large output capacitance can be advantageously employed to absorb the excess charge and minimize the voltage overshoot.

Equation 13 calculates the output capacitance to meet the dynamic specification of output voltage overshoot during such a load-off transient (denoted as $\Delta V_{OVERSHOOT}$ with step reduction in output current given by ΔI_{OUT}).

$$C_{OUT} \geq \frac{L_O \cdot \Delta I_{OUT}^2}{(V_{OUT} + \Delta V_{OVERSHOOT})^2 - V_{OUT}^2} \quad (14)$$

The capacitor manufacturer data sheet provides the ESR and ESL, either explicitly as specifications or implicitly in the impedance versus frequency curve. Depending on the type, size, and construction, electrolytic capacitors have significant ESR, 10m Ω and above, and relatively high ESL, 10nH to 20nH. PCB traces contribute some parasitic resistance and inductance as well. Ceramic output capacitors, have low ESR and ESL contributions at the switching frequency, and the capacitive impedance dominates. However, depending on the package and voltage rating of the ceramic capacitor, the effective capacitance can drop quite significantly with applied DC voltage and operating temperature.

Ignoring the ESR term in Equation 13 gives a quick estimation of the minimum ceramic capacitance necessary to meet the output ripple specification. Four 22 μ F, 25V, X7R capacitors in 1210 footprint are a common choice for a 12V output. Use Equation 14 to determine if additional capacitance is necessary to meet the load-off transient overshoot specification.

A composite implementation of ceramic and electrolytic capacitors highlights the rationale for paralleling capacitors of dissimilar chemistries yet complementary performance. The frequency response of each capacitor is accretive in that each capacitor provides desirable performance over a certain part of the applicable frequency

range. While the ceramic provides excellent mid- and high-frequency decoupling characteristics with low ESR and ESL to minimize the switching frequency output ripple, the electrolytic device with large bulk capacitance provides low-frequency energy storage to cope with lower frequency load-transient demands.

8.1.1.4 Input Capacitors

Input capacitors are necessary to limit the input ripple voltage to the buck power stage due to switching-frequency AC currents. TI recommends using X7S or X7R dielectric ceramic capacitors to provide low impedance and high RMS current rating over a wide temperature range. To minimize the parasitic inductance in the switching power loop, position the input capacitors as close as possible to the drain of the high-side MOSFET and the source of the low-side MOSFET. Use [Equation 15](#) to calculate the input capacitor RMS current for a single-channel buck regulator.

$$I_{CIN,rms} = \sqrt{D \cdot \left(I_{OUT}^2 \cdot (1-D) + \frac{\Delta I_L^2}{12} \right)} \quad (15)$$

The highest input capacitor RMS current occurs at $D = 0.5$, at which point the RMS current rating of the input capacitors is approximately equal to half the output current.

Ideally, the DC component of input current is provided by the input voltage source and the AC component by the input ceramic capacitors. Neglecting inductor ripple current, the input capacitors source current of amplitude $(I_{OUT} - I_{IN})$ during the D interval and sink I_{IN} during the $1-D$ interval. Thus, the input capacitors conduct a square-wave current of peak-to-peak amplitude equal to the output current. It follows that the resultant capacitive component of AC ripple voltage is a triangular waveform. Together with the ESR-related ripple component, use [Equation 16](#) to calculate the peak-to-peak ripple voltage amplitude.

$$\Delta V_{IN} = \frac{I_{OUT} \cdot D \cdot (1-D)}{F_{SW} \cdot C_{IN}} + I_{OUT} \cdot R_{ESR} \quad (16)$$

Use [Equation 17](#) to calculate the input capacitance required for a particular load current, based on an input voltage ripple specification of ΔV_{IN} .

$$C_{IN} \geq \frac{D \cdot (1-D) \cdot I_{OUT}}{F_{SW} \cdot (\Delta V_{IN} - R_{ESR} \cdot I_{OUT})} \quad (17)$$

Place low-ESR ceramic capacitors in parallel with a higher valued bulk capacitance to provide optimized input filtering for the regulator and damping to mitigate the effects of input parasitic inductance resonating with high-Q ceramics. While dependent on switching frequency and load current level, four 10 μ F, 50V, X7R, ceramic decoupling capacitors are usually sufficient for 12V battery automotive applications. As outlined in [Section 8.1.1.5](#), select the input bulk capacitor equal to three to four times the derated ceramic value and make sure the bulk capacitor is rated for the full operating temperature range.

Of course, a two-channel buck regulator with 180° out-of-phase interleaved switching provides input ripple current cancellation and reduced input capacitor current stress. The previous equations represent valid calculations when one channel is disabled and the other channel is loaded.

8.1.1.5 EMI Filter

Switching regulators exhibit a negative input impedance characteristic, which is lowest at the minimum input voltage and full load. An underdamped LC filter exhibits a high output impedance at the resonant frequency of the filter. For stability, the filter output impedance, approximated by the characteristic impedance of the LC components, must be less than the absolute value of the regulator input impedance.

$$Z_{IN} = \left| -\frac{V_{IN(min)}^2}{P_{IN}} \right| \quad (18)$$

The EMI filter design steps are as follows:

- Calculate the required attenuation of the EMI filter at the switching frequency, where C_{IN} represents the existing capacitance at the input of the switching regulator.
- The input filter inductor L_{IN} is usually selected between $1\mu\text{H}$ and $6.8\mu\text{H}$, but can be lower to reduce losses in a high-current design.
- Calculate input filter capacitor C_F .

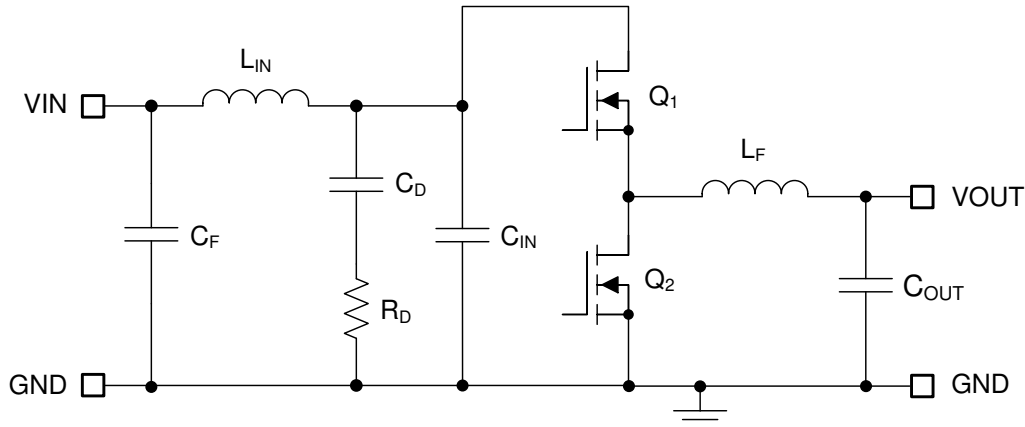

Figure 8-2. Buck Regulator With π -Stage EMI Filter

By calculating the first harmonic current from the Fourier series of the input current waveform and multiplying by the input impedance (the impedance is defined by the existing input capacitor C_{IN}), Equation 19 presents an expression to obtain the required attenuation.

$$\text{Attn} = 20 \log \left(\frac{I_{L(PEAK)}}{\pi^2 \cdot F_{SW} \cdot C_{IN}} \cdot \sin(\pi \cdot D_{MAX}) \cdot \frac{1}{1 \mu\text{V}} \right) - V_{MAX} \quad (19)$$

where

- V_{MAX} is the allowed dB μV noise level for the applicable conducted EMI specification (for example, CISPR 25 Class 5)
- C_{IN} is the existing input capacitance of the buck regulator
- D_{MAX} is the maximum operating duty cycle (at minimum input voltage)
- $I_{L(PEAK)}$ is the peak inductor current

For filter design purposes, the current at the input can be modeled as a square-wave. Determine the EMI filter capacitance C_F from Equation 20.

$$C_F = \frac{1}{L_{IN}} \left(\frac{10^{\frac{|Attn|}{40}}}{2\pi \cdot F_{SW}} \right)^2 \quad (20)$$

Adding an input filter to a switching regulator as shown in Figure 8-2 modifies the control-to-output transfer function. The output impedance of the filter must be sufficiently low such that the input filter does not significantly

affect the loop gain of the buck regulator. The impedance peaks at the filter resonant frequency. Use [Equation 21](#) to calculate the resonant frequency of the filter.

$$f_{\text{res}} = \frac{1}{2\pi \cdot \sqrt{L_{\text{IN}} \cdot C_{\text{F}}}} \quad (21)$$

The purpose of R_{D} in [Figure 8-2](#) is to reduce the peak output impedance of the filter at the resonant frequency. Capacitor C_{D} blocks the DC component of the input voltage to avoid excessive power dissipation in R_{D} . Capacitor C_{D} must have lower impedance than R_{D} at the resonant frequency with a capacitance value greater than that of the input capacitor C_{IN} . This requirement prevents C_{IN} from interfering with the cutoff frequency of the main filter. Added damping is needed when the output impedance of the filter is high at the resonant frequency (Q of the filter formed by L_{IN} and C_{IN} is too high). Use an electrolytic capacitor C_{D} for parallel damping with a value given by [Equation 22](#).

$$C_{\text{D}} \geq 4 \cdot C_{\text{IN}} \quad (22)$$

Use [Equation 23](#) to select the damping resistor R_{D} .

$$R_{\text{D}} = \sqrt{\frac{L_{\text{IN}}}{C_{\text{IN}}}} \quad (23)$$

8.1.2 Error Amplifier and Compensation

[Figure 8-3](#) shows a type-II compensator using a transconductance error amplifier (EA) for the voltage loop. As shown in [Equation 24](#), the dominant pole of the EA open-loop gain is set by the EA output resistance, $R_{\text{O-EA}}$, and effective bandwidth-limiting capacitance, C_{BW} .

$$G_{\text{EA(openloop)}}(s) = -\frac{g_{\text{m}} \cdot R_{\text{O-EA}}}{1 + s \cdot R_{\text{O-EA}} \cdot C_{\text{BW}}} \quad (24)$$

[Equation 24](#) neglects the EA parasitic high-frequency pole. Use [Equation 25](#) to calculate the compensator transfer function from output voltage to COMP node, including the gain contribution from the (internal or external) feedback resistor network

$$G_{\text{c}}(s) = \frac{\hat{v}_{\text{c}}(s)}{\hat{v}_{\text{out}}(s)} = -\frac{V_{\text{REF}}}{V_{\text{OUT}}} \cdot \frac{g_{\text{m}} \cdot R_{\text{O-EA}} \cdot \left(1 + \frac{s}{\omega_{\text{z1}}}\right)}{\left(1 + \frac{s}{\omega_{\text{p1}}}\right) \cdot \left(1 + \frac{s}{\omega_{\text{p2}}}\right)} \quad (25)$$

where

- V_{REF} is the internal feedback voltage reference of 0.8V
- g_{m} is the EA transconductance of 600 μS
- $R_{\text{O-EA}}$ is the error amplifier output resistance of 74M Ω

$$\omega_{\text{z1}} = \frac{1}{R_{\text{COMP}} \cdot C_{\text{COMP}}} \quad (26)$$

$$\omega_{p1} = \frac{1}{R_{O-EA} \cdot (C_{COMP} + C_{HF} + C_{BW})} \cong \frac{1}{R_{O-EA} \cdot C_{COMP}} \quad (27)$$

$$\omega_{p2} = \frac{1}{R_{COMP} \cdot (C_{COMP} \parallel (C_{HF} + C_{BW}))} \cong \frac{1}{R_{COMP} \cdot C_{HF}} \quad (28)$$

The EA compensation components create a pole close to the origin, a zero, and a high-frequency pole. Typically, $R_{COMP} \ll R_{O-EA}$ and $C_{COMP} \gg C_{BW}$ and C_{HF} , so the approximations are valid.

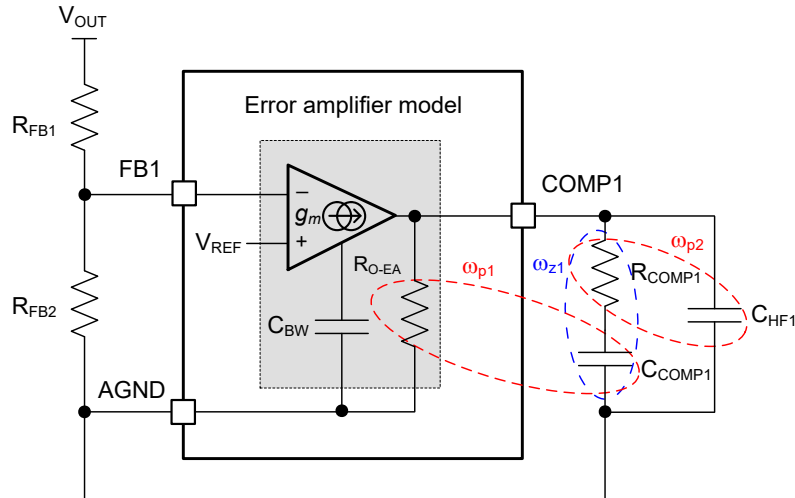

Figure 8-3. Voltage-loop Error Amplifier and Compensation Network

8.2 Typical Applications

Note

For step-by-step design procedure, circuit schematics, bill of materials, PCB files, simulation and test results of an LM5137-Q1-powered implementation, see the [TI Designs](#) reference design library.

8.2.1 Design 1 – Dual 5V and 3.3V, 20A Buck Regulator for 12V Automotive Battery Applications

Figure 8-4 shows the schematic diagram of a dual-output synchronous buck regulator with output voltage setpoints of 5V and 3.3V and a rated load current of 20A for each output. In this example, the target half-load and full-load efficiencies are 96% and 94%, respectively, based on a nominal input voltage of 13.5V that ranges from 6.5V to 36V. The switching frequency is set at 440kHz by resistor R_{RT} . The 5V output provides bias power to reduce IC power dissipation and improve efficiency.

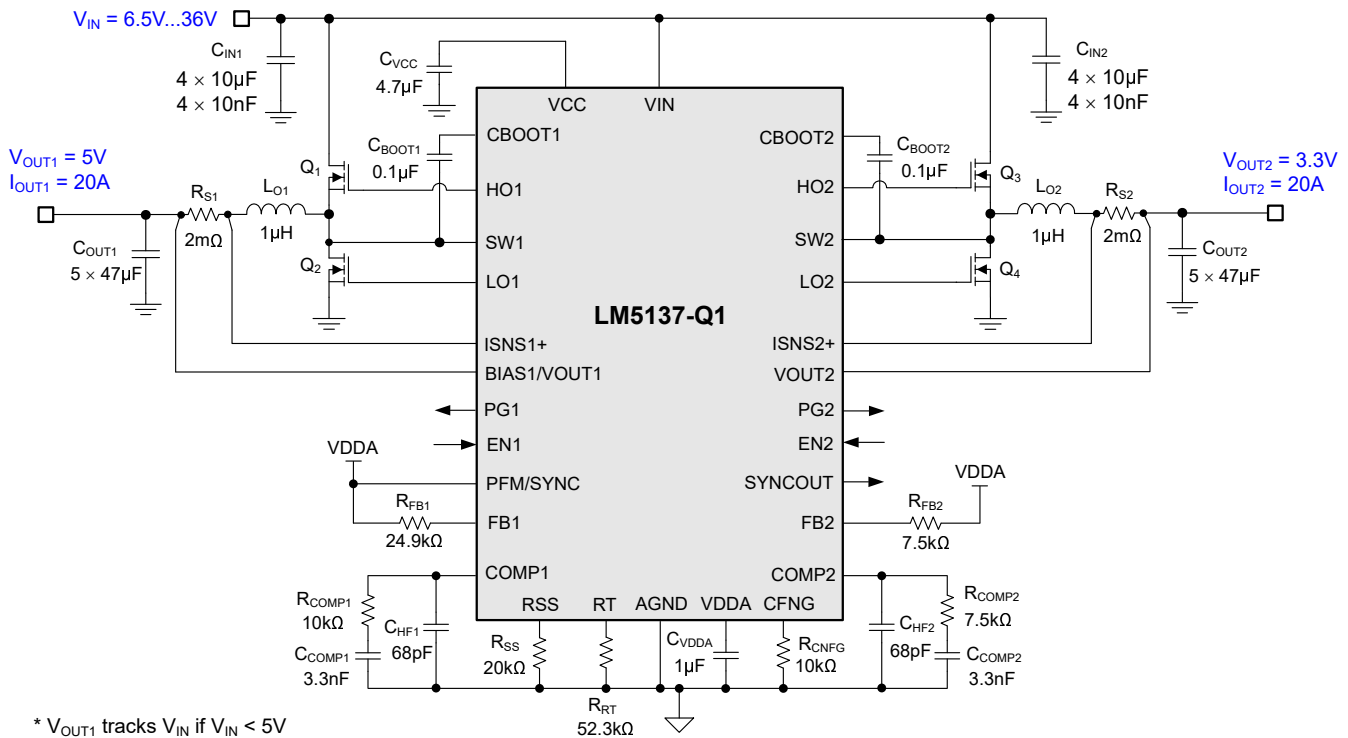

Figure 8-4. Application Circuit 1 Using The LM5137-Q1 Buck Controller at 440kHz

Note

This and subsequent circuit examples are provided herein to showcase the LM5137-Q1 controller in several different applications. Depending on the source impedance of the input supply, connect an input electrolytic capacitor to make sure of stability, particularly at low input voltage and high power operating conditions. See also [Section 8.3](#).

8.2.1.1 Design Requirements

Table 8-2 shows the intended input, output, and performance parameters for this automotive circuit example.

Table 8-2. Design Parameters

DESIGN PARAMETER	VALUE
Input voltage range (steady state)	6.5V to 36V, nominal 13.5V
Minimum transient input voltage (cold crank)	4.5V
Maximum transient input voltage (load dump)	36V
Output voltages	5V, 3.3V
Output currents (EDC) ⁽¹⁾	20A
Output currents (TDC) ⁽¹⁾	15A
Switching frequency	440kHz
Target efficiency at 5V, 15A	96%
Target efficiency at 3.3V, 15A	94.5%
Output voltage regulation	±1%
Loop crossover frequency	60kHz
Phase margin	> 45°
No-load sleep current, channel 2 disabled	< 20μA
Shutdown current	4μA

(1) EDC and TDC refer to electrical and thermal design currents, respectively.

Resistor R_{RT} sets the switching frequency at 440kHz. In terms of control loop performance, the target loop crossover frequency is set in the range of 10% to 15% of switching frequency – 60kHz in this example – with a target phase margin greater than 45°. Connecting a resistance of 20kΩ at RSS sets the output voltage soft-start times to 4.6ms.

Table 8-3 cites the selected buck regulator powertrain components, with many of the components available from multiple vendors. [Power MOSFETs](#) describes selection of power MOSFETs for lowest conduction and switching power loss. This application circuit uses 40V *logic-level* power MOSFETs, metal-alloy buck inductors with low DCR, low-ESL shunts, and ceramic input and output capacitors – all AEC qualified.

Table 8-3. List of Materials for Application Circuit 1

REFERENCE DESIGNATOR	QTY	SPECIFICATION ⁽¹⁾	MANUFACTURER	PART NUMBER
C _{IN1} , C _{IN2}	8	10μF, 50V, X7R, 1210, ceramic, AEC-Q200	TDK	CNA6P1X7R1H106K
		10μF, 50V, X7S, 1210, ceramic, AEC-Q200	Murata	GCM32EC71H106K
C _{OUT1} , C _{OUT2}	8	47μF, 10V, X7S, 1210, ceramic, AEC-Q200	TDK	CGA6P3X7S1H106K
			Murata	GCM32EC71A476K
L _{O1} , L _{O2}	2	1μH, 2.3mΩ, 37A, 10.85 × 10 × 5.2mm, AEC-Q200	Cyntec	VCHA105D-1R0MS6
		1μH, 2.3mΩ, 37A, 11 × 10 × 5.1mm, AEC-Q200	Bourns	SRP1050WA-1R0M
		1μH, 2.1mΩ, 24A, 10.8 × 10 × 5mm, AEC-Q200	Eaton	HCM1A1105V2-1R0-R
		1μH, 2.7mΩ, 33.8A, 10.85 × 10 × 3.8mm, AEC-Q200	Würth Elektronik	784373680010
		1μH, 2.4mΩ, 36.6A, 10.5 × 10 × 6.5mm, AEC-Q200	TDK	SPM10065VT-1R0M-D
Q ₁ , Q ₃	2	40V, 3.6mΩ, 9nC, SON 5 × 6, AEC-Q101	Infineon	IAUCN04S7L028ATMA1
Q ₂ , Q ₄	2	40V, 2.4mΩ, 15nC, SON 5 × 6, AEC-Q101	Infineon	IAUCN04S7L019ATMA1
R _{S1} , R _{S2}	2	Shunt, 2mΩ ±2%, ±100ppm/°C, 1225, 3W, AEC-Q200	Susumu	KRL6432E-M-R002-G
U ₁	1	LM5137-Q1 80V dual-output buck controller, AEC-Q100	Texas Instruments	LM5137QRHARQ1

(1) See the *Third-Party Products Disclaimer*.

8.2.1.2 Detailed Design Procedure

8.2.1.2.1 Custom Design With WEBENCH® Tools

[Click here](#) to create a custom design using the LM5137-Q1 device with the WEBENCH® Power Designer.

1. Start by entering the input voltage (V_{IN}), output voltage (V_{OUT}), and output current (I_{OUT}) requirements.
2. Optimize the design for key parameters such as efficiency, footprint, and cost using the optimizer dial.
3. Compare the generated design with other possible solutions from Texas Instruments.

The WEBENCH Power Designer provides a customized schematic along with a list of materials with real-time pricing and component availability.

In most cases, these actions are available:

- Run electrical simulations to see important waveforms and circuit performance
- Run thermal simulations to understand board thermal performance
- Export customized schematic and layout into popular CAD formats
- Print PDF reports for the design, and share the design with colleagues

Get more information about WEBENCH tools at www.ti.com/WEBENCH.

8.2.1.2.2 Custom Design With Excel Quickstart Tool

Select components based on the regulator specifications using the LM5137-Q1 [Quickstart Calculator](#) available for download from the LM5137-Q1 product folder.

8.2.1.2.3 Inductor Calculations

1. Use [Equation 29](#) to calculate the required buck inductance for each channel based on an approximate 30% inductor peak-to-peak ripple current at nominal input voltage.

$$L_{O1} = \frac{V_{OUT1}}{\Delta I_{LO1} \cdot F_{SW}} \cdot \left(1 - \frac{V_{OUT1}}{V_{IN(nom)}}\right) = \frac{5V}{6A \cdot 440kHz} \cdot \left(1 - \frac{5V}{12V}\right) = 1.1\mu H$$

$$L_{O2} = \frac{V_{OUT2}}{\Delta I_{LO2} \cdot F_{SW}} \cdot \left(1 - \frac{V_{OUT2}}{V_{IN(nom)}}\right) = \frac{3.3V}{6A \cdot 440kHz} \cdot \left(1 - \frac{3.3V}{12V}\right) = 0.9\mu H \quad (29)$$

2. Select a standard inductor value of $1\mu H$ for both channels. Use [Equation 30](#) to calculate the peak inductor currents at maximum steady-state input voltage. Subharmonic oscillation occurs with a duty cycle greater than 50% for peak current-mode control. For design simplification, the LM5137-Q1 has an internal slope compensation ramp proportional to the switching frequency that is added to the current sense signal to damp any tendency toward subharmonic oscillation.

$$I_{LO1(PK)} = I_{OUT1} + \frac{\Delta I_{LO1}}{2} = I_{OUT1} + \frac{V_{OUT1}}{2 \cdot L_{O1} \cdot F_{SW}} \cdot \left(1 - \frac{V_{OUT1}}{V_{IN(max)}}\right) = 20A + \frac{5V}{2 \cdot 1\mu H \cdot 440kHz} \cdot \left(1 - \frac{5V}{36V}\right) = 24.9A$$

$$I_{LO2(PK)} = I_{OUT2} + \frac{\Delta I_{LO2}}{2} = I_{OUT2} + \frac{V_{OUT2}}{2 \cdot L_{O2} \cdot F_{SW}} \cdot \left(1 - \frac{V_{OUT2}}{V_{IN(max)}}\right) = 20A + \frac{3.3V}{2 \cdot 1\mu H \cdot 440kHz} \cdot \left(1 - \frac{3.3V}{36V}\right) = 23.4A \quad (30)$$

3. Based on [Equation 29](#), use [Equation 31](#) to cross-check the inductances to align the slope compensation ramp to an ideal one times the inductor current downslope.

$$L_{O1,sc} = \frac{V_{OUT} [V] \cdot R_S [m\Omega]}{22 \cdot F_{SW} [MHz]} = \frac{5V \cdot 2m\Omega}{22 \cdot 0.44MHz} = 1.03\mu H$$

$$L_{O2,sc} = \frac{V_{OUT} [V] \cdot R_S [m\Omega]}{22 \cdot F_{SW} [MHz]} = \frac{3.3V \cdot 2m\Omega}{22 \cdot 0.44MHz} = 0.68\mu H \quad (31)$$

8.2.1.2.4 Shunt Resistors

1. Calculate the shunt resistance based on a maximum peak current capability at least 20% higher than the peak inductor current at full load to provide sufficient margin during start-up and load-step transients. Use [Equation 32](#) to calculate the shunt resistances.

$$R_{S1} = \frac{V_{CS(th)}}{1.2 \cdot I_{LO1(PK)}} = \frac{60mV}{1.2 \cdot 24.9A} = 2.01m\Omega$$

$$R_{S2} = \frac{V_{CS(th)}}{1.2 \cdot I_{LO2(PK)}} = \frac{60mV}{1.2 \cdot 23.4A} = 2.14m\Omega \quad (32)$$

where

- $V_{CS(th)}$ is the 60mV current limit threshold.
2. Select a standard resistance value of 2m Ω for both shunts. A 1225 footprint component with wide aspect ratio termination design provides a 3W power rating, parasitic inductance (ESL) less than 1nH, and compact PCB layout. Carefully adhere to the layout guidelines in [Layout Guidelines](#) to make sure that noise and DC errors do not corrupt the current-sense voltages measured differentially at the [ISNS1+, VOUT1] and [ISNS2+, VOUT2] pins.
 3. Place the shunt resistor close to the inductor.
 4. Use Kelvin sense connections and route the sense lines differentially from the shunt to the applicable pins of the LM5137-Q1.
 5. The current-sense-to-output propagation delay (related to the current limit comparator, internal logic and power MOSFET gate drivers) causes the peak current to increase above the calculated current limit threshold. For a total propagation delay of $t_{CS-DELAY}$ of 70ns, use [Equation 33](#) to calculate the worst-case peak inductor current with the output shorted.

$$I_{LO1,pk-sc} = I_{LO2,pk-sc} = \frac{V_{CS(th)}}{R_{S1}} + \frac{V_{IN(max)} \cdot t_{CS-DELAY}}{L_{O1}} = \frac{60mV}{2m\Omega} + \frac{36V \cdot 70ns}{1\mu H} = 32.5A \quad (33)$$

6. Based on this result, select an inductor for each channel with saturation current greater than 33A across the full operating temperature range.

8.2.1.2.5 Ceramic Output Capacitors

1. Use [Equation 34](#) to estimate the output capacitance required to manage the output voltage overshoot during a load-off transient of 10A, assuming a load transient deviation specification of 100mV.

$$C_{OUT1} \geq \frac{L_{O1} \cdot \Delta I_{OUT1}^2}{(V_{OUT1} + \Delta V_{OVERSHOOT1})^2 - V_{OUT1}^2} = \frac{1\mu H \cdot (10A)^2}{(5V + 100mV)^2 - (5V)^2} = 99\mu F$$

$$C_{OUT2} \geq \frac{L_{O2} \cdot \Delta I_{OUT2}^2}{(V_{OUT2} + \Delta V_{OVERSHOOT2})^2 - V_{OUT2}^2} = \frac{1\mu H \cdot (10A)^2}{(3.3V + 100mV)^2 - (3.3V)^2} = 149\mu F \quad (34)$$

2. Noting the voltage coefficient of ceramic capacitors where the effective capacitance decreases significantly with applied voltage, select four 47 μ F, 10V, X7R, 1210 ceramic output capacitors for each channel.

According to the design tool from the capacitor vendor, these capacitors are each effectively 32μF and 41μF at 5V and 3.3V DC voltage, respectively.

- Use [Equation 35](#) to estimate the peak-to-peak output voltage ripple of channel 1 at nominal input voltage.

$$\Delta V_{OUT1} = \Delta I_{LO1} \cdot \sqrt{\frac{1}{(8 \cdot F_{SW} \cdot C_{OUT1})^2} + R_{ESR}^2} = 6.8A \cdot \sqrt{\frac{1}{(8 \cdot 440kHz \cdot 128\mu F)^2} + (1m\Omega)^2} \approx 16mV \quad (35)$$

where

- R_{ESR} is the effective equivalent series resistance (ESR) of the output capacitors.
 - 128μF is the total effective (derated) ceramic output capacitance at 5V.
- Use [Equation 36](#) to calculate the output capacitor RMS ripple current at maximum input voltage. Verify that the output capacitor RMS ripple current at maximum input voltage is within the capacitor ripple current rating.

$$I_{CO1,RMS} = \frac{\Delta I_{LO1}}{\sqrt{12}} = \frac{10A}{\sqrt{12}} = 2.9A$$

$$I_{CO2,RMS} = \frac{\Delta I_{LO2}}{\sqrt{12}} = \frac{7A}{\sqrt{12}} = 2A \quad (36)$$

8.2.1.2.6 Ceramic Input Capacitors

A power supply input typically has a relatively high source impedance at the switching frequency. Good-quality input capacitors are necessary to limit the input ripple voltage. As mentioned earlier, dual-channel interleaved operation significantly reduces the input ripple amplitude. In general, the ripple current splits between the input capacitors based on the relative impedance of the capacitors at the switching frequency.

- Select the input capacitors with sufficient voltage and RMS ripple current ratings.
- Worst case input ripple for a two-channel buck regulator typically corresponds to when one channel operates at full load and the other channel is disabled or operates at no load. Use [Equation 37](#) to calculate the input capacitor RMS ripple current assuming a worst-case duty-cycle operating point of 50%.

$$I_{CIN,RMS} = I_{OUT1} \cdot \sqrt{D \cdot (1-D)} = 20A \cdot \sqrt{0.5 \cdot (1-0.5)} = 10A \quad (37)$$

- Use [Equation 38](#) to find the required input capacitance.

$$C_{IN} \geq \frac{D \cdot (1-D) \cdot I_{OUT1}}{F_{SW} \cdot (\Delta V_{IN} - R_{ESR} \cdot I_{OUT1})} = \frac{0.5 \cdot (1-0.5) \cdot 20A}{440kHz \cdot (270mV - 1m\Omega \cdot 20A)} = 45\mu F \quad (38)$$

where

- ΔV_{IN} is the input peak-to-peak ripple voltage specification.
 - R_{ESR} is the input capacitor ESR.
- Recognizing the voltage coefficient of ceramic capacitors, select four 10μF, 50V, X7R, 1210 ceramic input capacitors for each channel. Place these capacitors adjacent to the relevant power MOSFETs.
 - Use four 10nF, 50V, X7R, 0603 ceramic capacitors near each high-side MOSFET to supply the high di/dt current during MOSFET switching transitions. Such capacitors offer high self-resonant frequency (SRF) and low effective impedance above 100MHz. The result is lower power loop parasitic inductance, thus minimizing switch-node voltage overshoot and ringing for lower EMI signature. Refer to [Figure 8-29](#) and [Figure 8-31](#) for additional context.

8.2.1.2.7 Feedback Resistors

Configure the dual outputs for fixed 5V and 3.3V voltage setpoints by tying the respective FB pins to VDDA through 24.9kΩ and 7.5kΩ resistors, respectively.

Alternatively, use feedback resistor dividers values for 5V and 3.3V output voltage setpoints based on the 0.8V feedback reference of the LM5137-Q1. Calculate the upper feedback resistors using [Equation 39](#) assuming a value of 15kΩ for the lower resistors.

$$R_{FB1} = R_{FB2} \cdot \left(\frac{V_{OUT1}}{V_{REF}} - 1 \right) = 15 \text{ k}\Omega \cdot \left(\frac{5 \text{ V}}{0.8 \text{ V}} - 1 \right) = 78.75 \text{ k}\Omega$$

$$R_{FB3} = R_{FB4} \cdot \left(\frac{V_{OUT1}}{V_{REF}} - 1 \right) = 15 \text{ k}\Omega \cdot \left(\frac{3.3 \text{ V}}{0.8 \text{ V}} - 1 \right) = 46.88 \text{ k}\Omega \quad (39)$$

[Equation 40](#) calculates the resultant output voltage setpoints when using 78.7kΩ, 47kΩ and 15kΩ standard E192 0.5% resistor values.

$$V_{OUT1} = V_{REF} \cdot \left(1 + \frac{R_{FB2}}{R_{FB1}} \right) = 0.8 \text{ V} \cdot \left(1 + \frac{78.7 \text{ k}\Omega}{15 \text{ k}\Omega} \right) = 4.997 \text{ V}$$

$$V_{OUT2} = V_{REF} \cdot \left(1 + \frac{R_{FB3}}{R_{FB4}} \right) = 0.8 \text{ V} \cdot \left(1 + \frac{47 \text{ k}\Omega}{15 \text{ k}\Omega} \right) = 3.306 \text{ V} \quad (40)$$

In contrast to a fixed output option, installing a feedback resistor divider with a suitable series resistor, typically 50Ω, facilitates measurement of the loop gain characteristic as needed to characterize stability.

8.2.1.2.8 Input Voltage UVLO Resistors

Use [Equation 41](#) and [Equation 42](#) to calculate the input UVLO divider resistors, designated as R_{UV1} and R_{UV2} in [Figure 7-2](#), given input turn-on and turn-off voltages specified as 6.5V and 4.5V, respectively. Use a 10kΩ resistor in series with the applicable EN pin, designated as R_{UV3} , to increase the effective voltage hysteresis without using higher divider resistances.

$$R_{UV2} = \left[\frac{V_{EN(off)} - (V_{IN(off)} / V_{IN(on)}) \cdot V_{EN(on)}}{I_{EN(hys)}} - R_{UV3} \right] \cdot \frac{V_{IN(on)}}{V_{IN(on)} - V_{EN(on)}}$$

$$= \left[\frac{0.95 \text{ V} - (4.5 \text{ V} / 6.5 \text{ V}) \cdot 1 \text{ V}}{10 \mu\text{A}} - 10 \text{ k}\Omega \right] \cdot \frac{6.5 \text{ V}}{6.5 \text{ V} - 1 \text{ V}} = 18.6 \text{ k}\Omega \quad (41)$$

$$R_{UV1} = R_{UV2} \cdot \left(\frac{V_{IN(on)}}{V_{EN(on)}} - 1 \right) = 19.1 \text{ k}\Omega \cdot \left(\frac{6.5 \text{ V}}{1 \text{ V}} - 1 \right) = 105 \text{ k}\Omega \quad (42)$$

Selecting standard 1% resistor values of 105kΩ and 19.1kΩ, calculate the actual input voltage turn-on and turn-off setpoints using [Equation 43](#).

$$V_{IN(on)} = V_{EN(on)} \cdot \left(1 + \frac{R_{UV1}}{R_{UV2}} \right) = 1V \cdot \left(1 + \frac{105k\Omega}{19.1k\Omega} \right) = 6.5V$$

$$V_{IN(off)} = \left[V_{EN(off)} - I_{EN(hys)} \cdot (R_{UV3} + R_{UV1} \parallel R_{UV2}) \right] \cdot \left(1 + \frac{R_{UV1}}{R_{UV2}} \right)$$

$$= \left[0.95V - 10\mu A \cdot (10k\Omega + 105k\Omega \parallel 19.1k\Omega) \right] \cdot \left(1 + \frac{105k\Omega}{19.1k\Omega} \right) = 4.5V \quad (43)$$

8.2.1.2.9 Compensation Components

Choose compensation components for a stable control loop using the procedure outlined as follows.

1. Based on the target loop crossover frequency, f_C , of 60kHz, use Equation 44 to calculate R_{COMP1} , assuming an effective output capacitance of 128μF. Select R_{COMP1} equal to 10kΩ.

$$R_{COMP1} = 2 \cdot \pi \cdot f_C \cdot \frac{V_{OUT}}{V_{REF}} \cdot \frac{R_S \cdot G_{CS}}{g_m} \cdot C_{OUT} = 2 \cdot \pi \cdot 60kHz \cdot \frac{5V}{0.8V} \cdot \frac{2m\Omega \cdot 10}{600\mu S} \cdot 128\mu F = 10k\Omega \quad (44)$$

2. Calculate C_{COMP1} to create a zero at the higher of (1) one tenth of the crossover frequency, or (2) the load pole. Select a capacitor value for C_{COMP1} of 3.3nF. In general, set the time constant of R_{COMP1} and C_{COMP1} at approximately 25μs to maintain a fast settling time of the output voltage following a load transient.

$$C_{COMP1} = \frac{10}{2 \cdot \pi \cdot f_C \cdot R_{COMP1}} = \frac{10}{2 \cdot \pi \cdot 60kHz \cdot 10k\Omega} = 2.6nF \quad (45)$$

3. Calculate C_{HF1} to create a pole at the lower of the ESR zero frequency or at half switching frequency (to attenuate high-frequency noise). Select a capacitor value for C_{HF1} of 68pF.

$$C_{HF1} = \frac{1}{2 \cdot \pi \cdot \frac{F_{SW}}{2} \cdot R_{COMP1}} = \frac{1}{2 \cdot \pi \cdot 220kHz \cdot 10k\Omega} = 72pF \quad (46)$$

Note

Set a high loop crossover frequency with high R_{COMP} and low C_{COMP} values to improve the large-signal response when recovering from operation in dropout.

LM5137-Q1

SNVSCU2B – AUGUST 2024 – REVISED AUGUST 2025

8.2.1.3 Application Curves

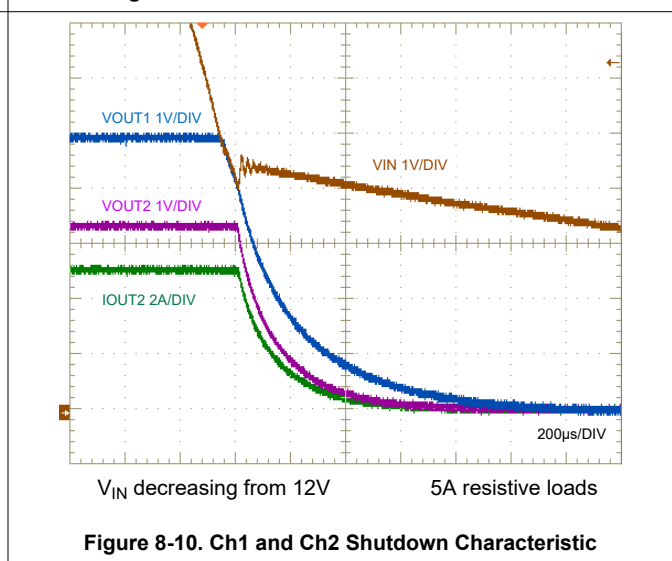
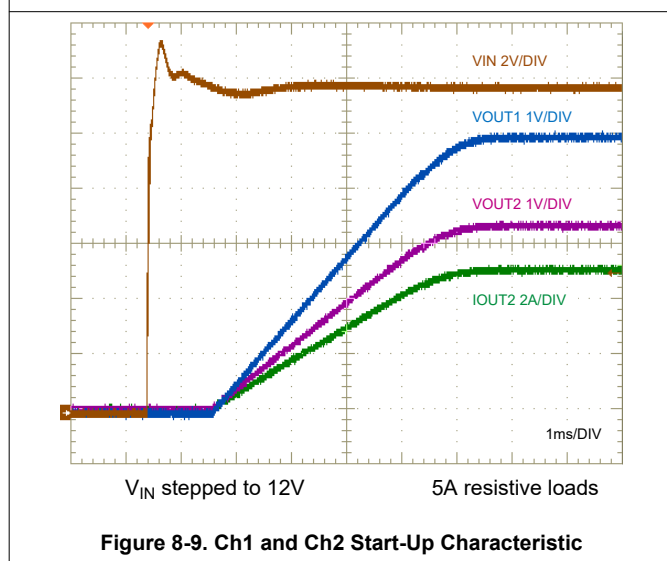
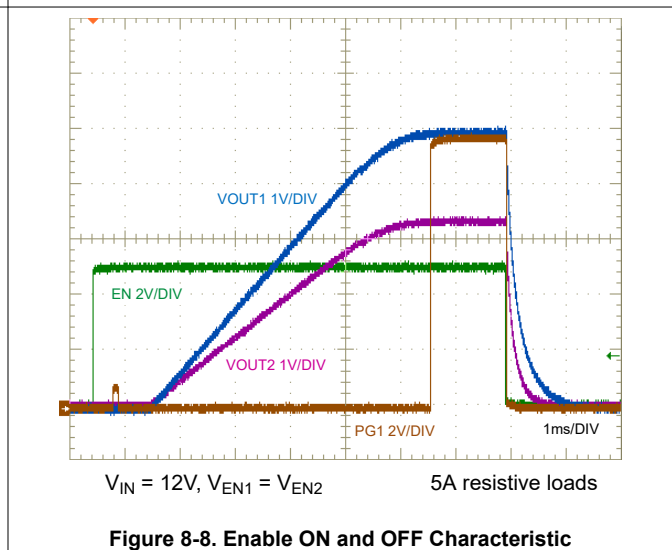
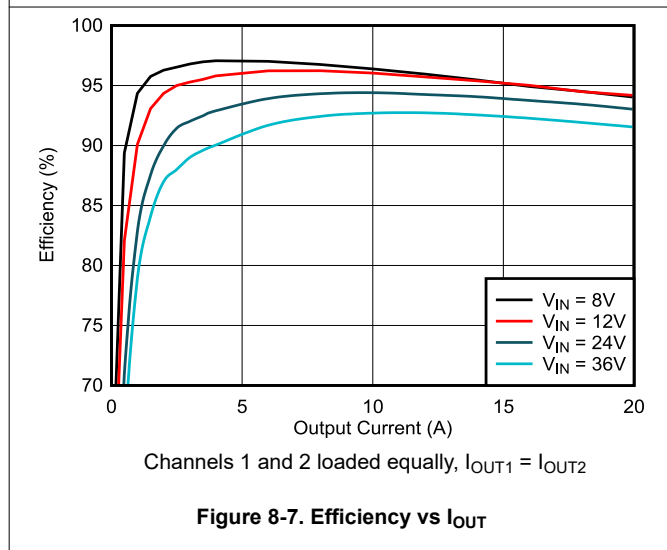
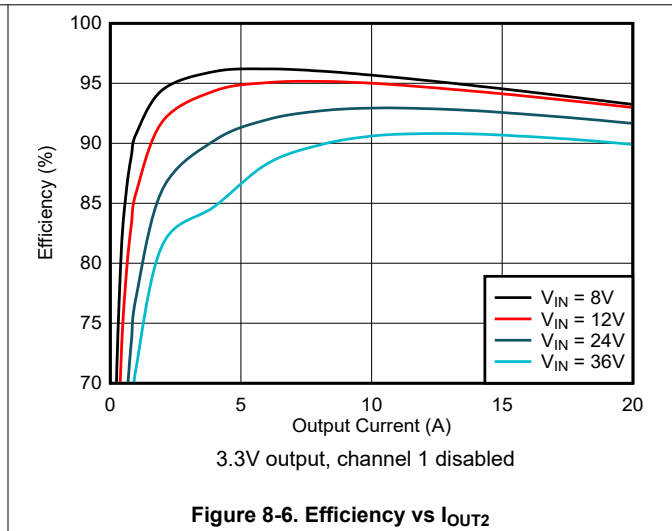
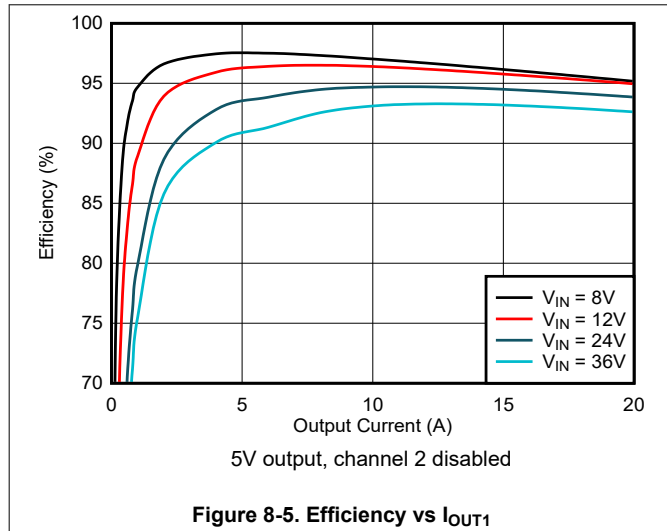

8.2.1.3 Application Curves (continued)

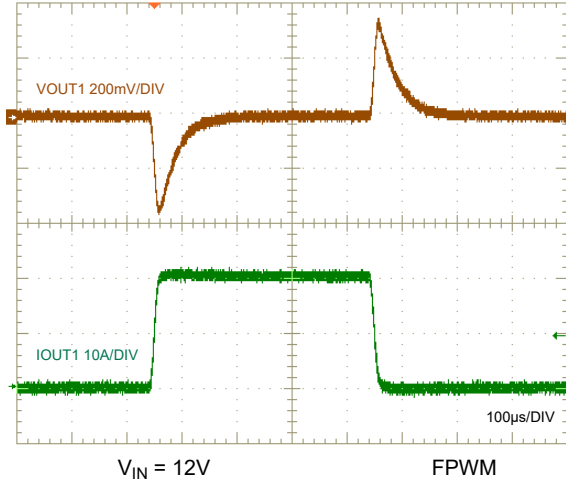

Figure 8-11. Load Transient, 5V Output, 0A to 20A

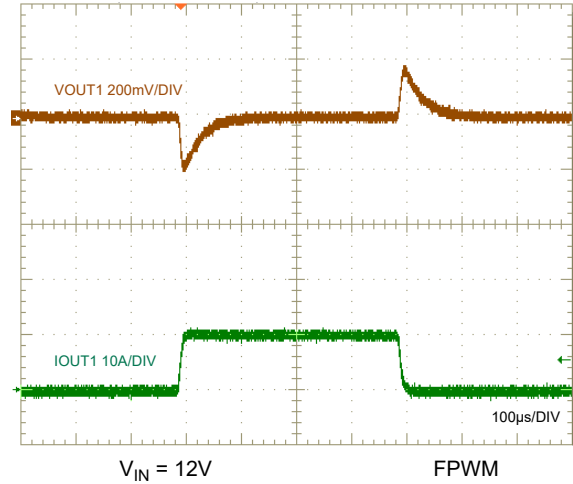

Figure 8-12. Load Transient, 5V Output, 0A to 10A

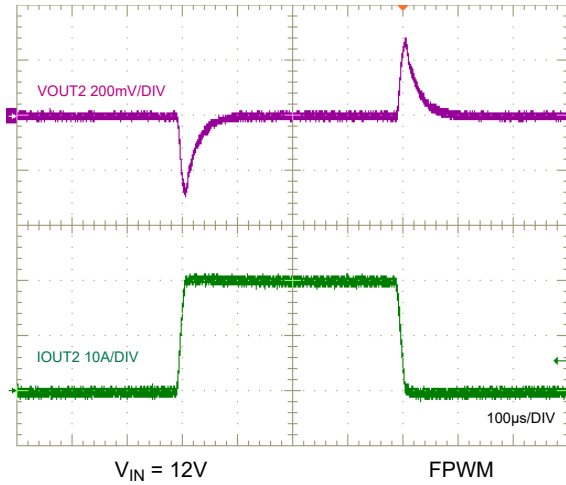

Figure 8-13. Load Transient, 3.3V Output, 0A to 20A

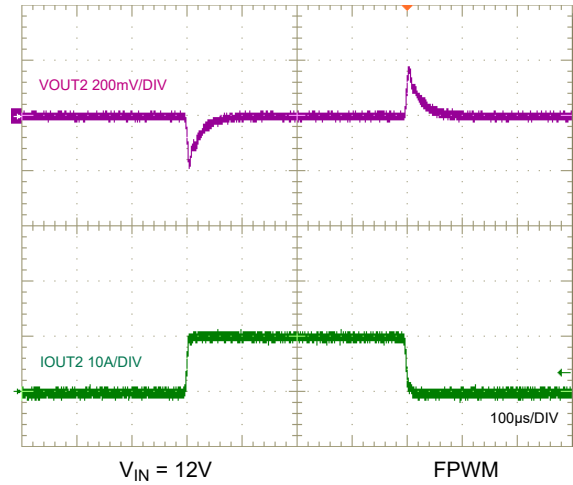

Figure 8-14. Load Transient, 3.3V Output, 0A to 10A

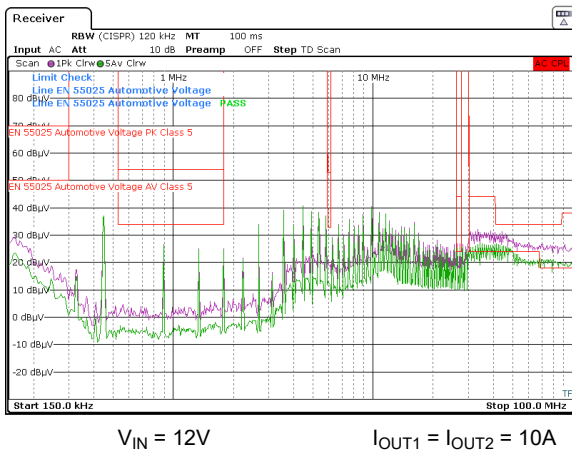

Figure 8-15. CISPR 25 Class 5 EMI Performance, Both Outputs Loaded at 10A

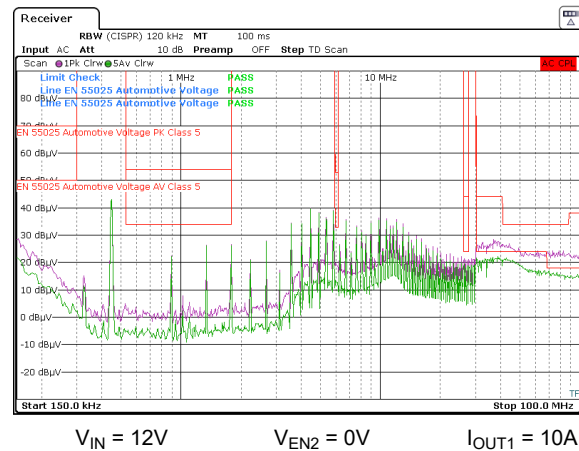
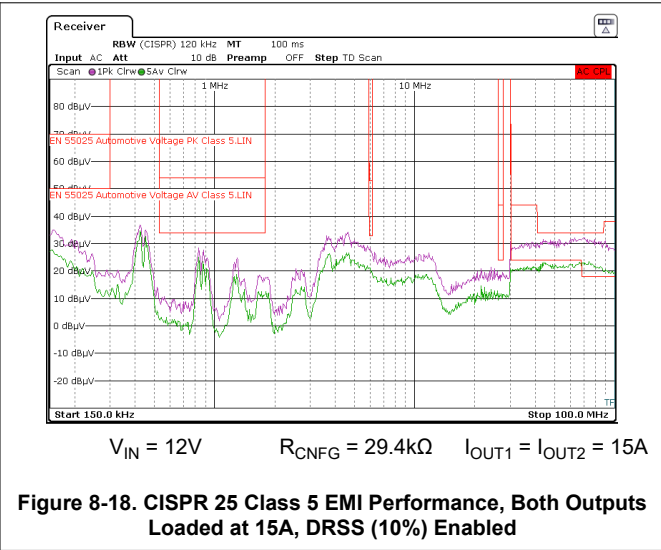
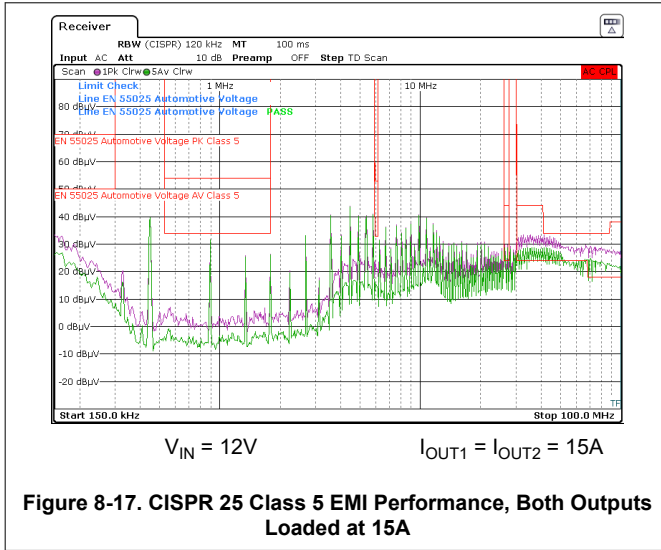

Figure 8-16. CISPR 25 Class 5 EMI Performance, 5V Output at 10A, Ch2 Disabled

8.2.1.3 Application Curves (continued)



8.2.2 Design 2 – Two-Phase, Single-Output Synchronous Buck Regulator for Automotive ADAS Applications

Figure 8-19 shows the schematic diagram of a single-output, two-phase synchronous buck regulator with an output voltage of 5V and rated load current of 20A. In this example, the target half-load and full-load efficiencies are 93% and 91%, respectively, based on a nominal input voltage of 12V that ranges from 6V to 36V. The switching frequency is set at 2.1MHz by resistor R_{RT} . The 5V output supplies bias current to the controller to improve light-load efficiency. An output voltage of 3.3V is also possible simply by changing the voltage-set resistor (R_{FB} tied from FB1 to VDDA) from 24.9k Ω to 7.5k Ω .

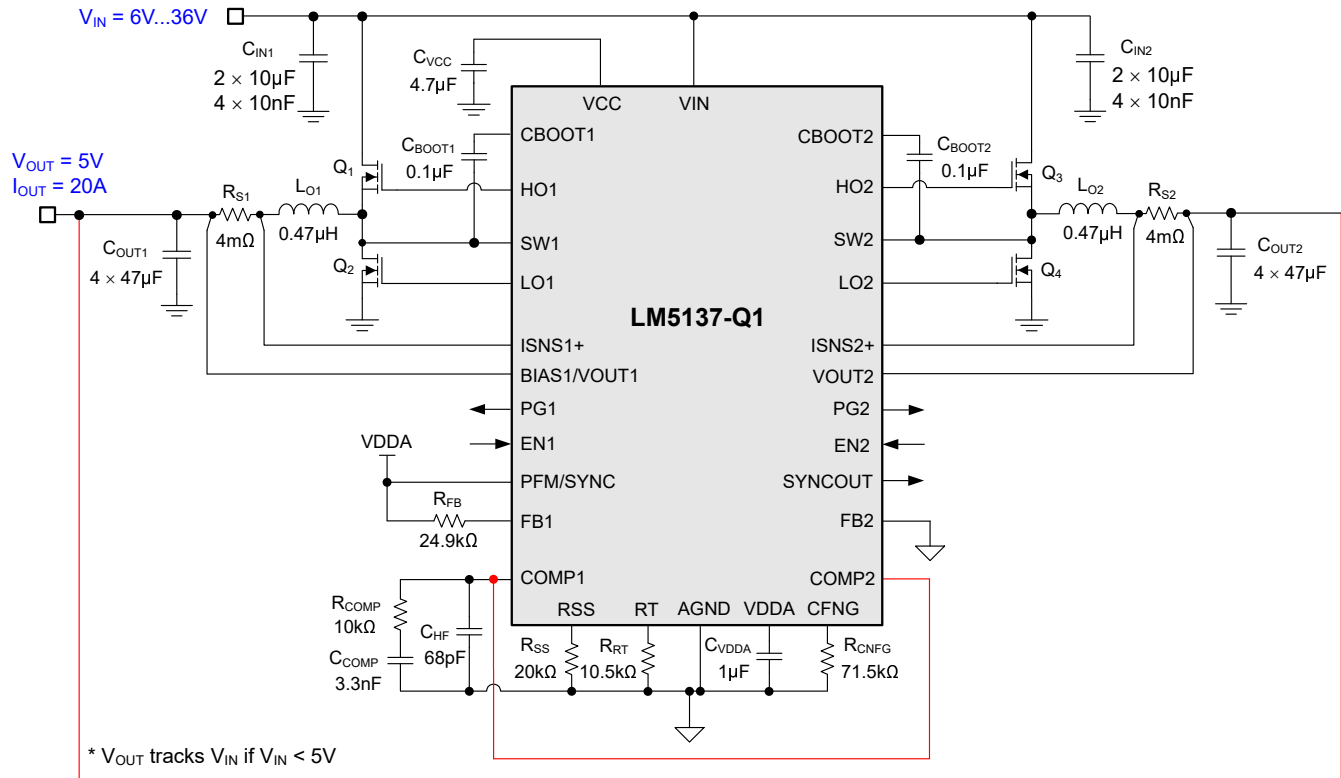

Figure 8-19. Application Circuit 2 With an LM5137-Q1 Two-phase Buck Regulator at 2.1MHz

8.2.2.1 Design Requirements

Table 8-4 shows the intended input, output, and performance parameters for this automotive circuit example.

Table 8-4. Design Parameters

DESIGN PARAMETER	VALUE
Input voltage range (steady state)	8V to 18V
Minimum transient input voltage (cold crank)	6V
Maximum transient input voltage (load dump)	36V
Output voltage	5V
Output current	20A
Switching frequency	2.1MHz
Output voltage regulation	±1%
No-load sleep current with phase 2 disabled	< 20µA
Shutdown current	4µA

Resistor R_{RT} of 10.5k Ω sets the switching frequency at 2.1MHz. In terms of control loop performance, the target loop crossover frequency is 80kHz with a phase margin greater than 50°. Leaving the RSS pin open sets the output voltage soft-start time to 6.5ms.

Table 8-5 cites the selected buck regulator powertrain components, with many of the components available from multiple vendors. Similar to circuit example 1, this design uses 40V logic-level MOSFETs, shielded buck inductors, shunt resistors with wide aspect ratio for low ESL, and an all-ceramic input and output capacitor implementation.

Table 8-5. List of Materials for Application Circuit 2

REFERENCE DESIGNATOR	QTY	SPECIFICATION ⁽¹⁾	MANUFACTURER	PART NUMBER
C _{IN1} , C _{IN2}	4	10 μ F, 50V, X7R, 1210, ceramic, AEC-Q200	TDK	CNA6P1X7R1H106K
		10 μ F, 50V, X7S, 1210, ceramic, AEC-Q200	Murata	GCM32EC71H106KA03
			TDK	CGA6P3X7S1H106M
C _{OUT1} , C _{OUT2}	8	47 μ F, 6.3V, X7R, 1210, ceramic, AEC-Q200	Murata	GCM32ER70J476KE19L
		47 μ F, 6.3V, X7S, 1210, ceramic, AEC-Q200	Taiyo Yuden	JMK325B7476KMHTR
			TDK	CGA6P1X7S0J476M
L _{O1} , L _{O2}	2	0.47 μ H, 2.2m Ω , 26.5A, 6.71 × 6.51 × 3.1mm, AEC-Q200	Coilcraft	XGL6030-471MEC
		0.47 μ H, 3m Ω , 25A, 6.95 × 6.6 × 4.3mm, AEC-Q200	Cyntec	VCUW064ER47MS5
		0.47 μ H, 3.1m Ω , 20A, 7 × 6.9 × 3.8mm, AEC-Q200	Würth Electronik	744311047
		0.56 μ H, 3m Ω , 29A, 6.6 × 6.4 × 2.8mm, AEC-Q200	Bourns	SRP6030CA-R56M
Q ₁ , Q ₃	2	40V, 4.7m Ω , 7nC, SON 5 × 6, AEC-Q101	Infineon	IAUC60N04S6L039ATMA
Q ₂ , Q ₄	2	40V, 3.6m Ω , 9nC, SON 5 × 6, AEC-Q101	Infineon	IAUCN04S7L028ATMA
R _{S1} , R _{S2}	2	Shunt, 4m Ω ±1%, ±50ppm/°C, 0612, 1.5W, AEC-Q200	Susumu	KRL3216E-C-R004-F
U ₁	1	LM5137-Q1 80V two-phase buck controller, AEC-Q100	Texas Instruments	LM5137QRHARQ1

(1) See *Third-Party Products Disclaimer*.

8.2.2.2 Detailed Design Procedure

See [Section 8.2.1.2](#).

8.2.3 Design 3 – 12V, 20A, 400kHz, Two-Phase Buck Regulator for 48V Automotive Applications

Figure 8-20 shows the schematic diagram of a single-output, two-phase synchronous buck regulator with an output voltage of 12V and rated load current of 20A. In this example, the target half-load and full-load efficiencies are above 95% based on a nominal input voltage of 48V that ranges from 36V to 65V, with transients to 20V and 72V. The switching frequency is set at 400kHz by resistor R_{RT} . Bias power derives from the 12V output, thus improving light-load efficiency. R_{FB} of 48.7k Ω (connected from FB1 to VDDA) establishes a fixed output setting of 12V.

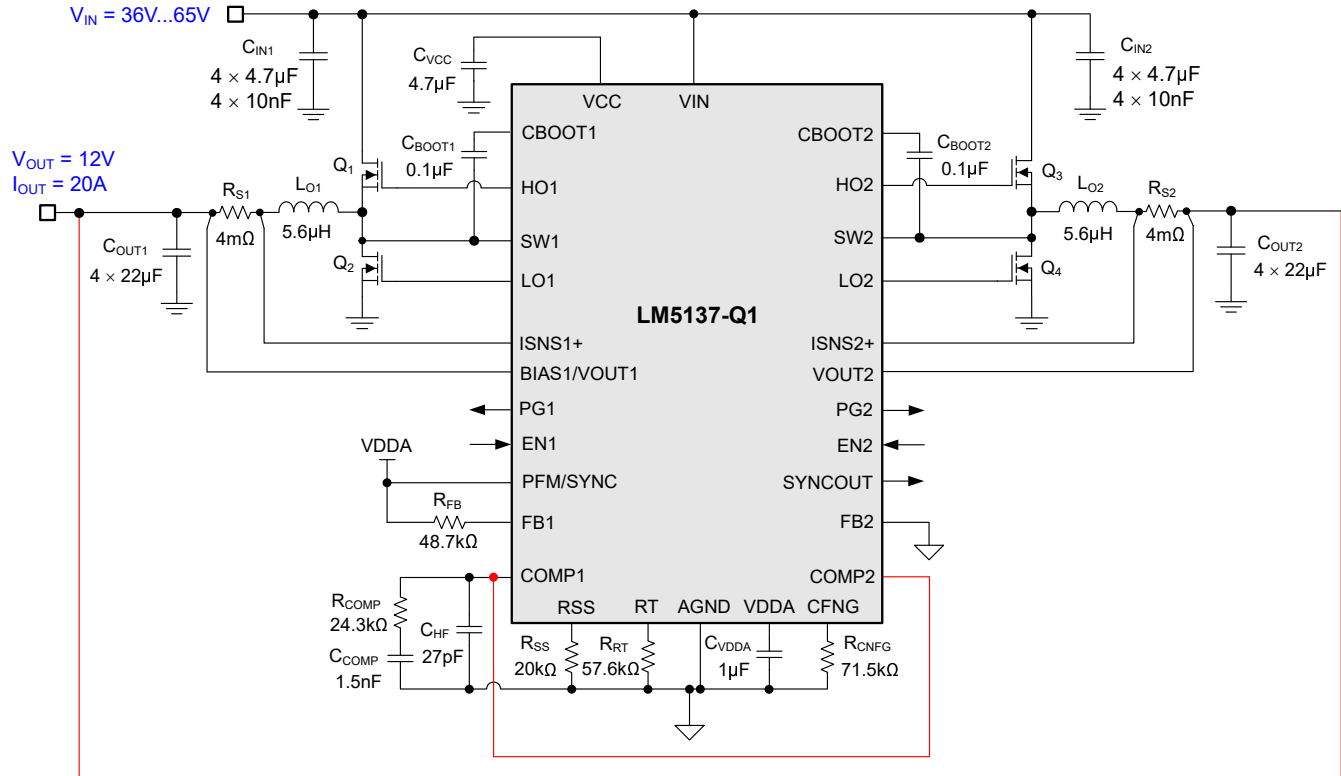

Figure 8-20. Application Circuit 3 With an LM5137-Q1 Two-phase Buck Regulator at 400kHz

8.2.3.1 Design Requirements

Table 8-6 shows the intended input, output, and performance parameters for this circuit example.

Table 8-6. Design Parameters

DESIGN PARAMETER	VALUE
Input voltage range (steady state)	36V to 65V
Nominal input voltage	48V
Minimum transient input voltage	20V
Maximum transient input voltage	72V
Output voltage setpoint	12V
Rated output current	20A
Switching frequency	400kHz
Target efficiency at 10A, 20A	96%, 95.5%
Input voltage UVLO on, off	23V, 19V
No-load sleep current with phase 2 disabled	< 20 μ A
Shutdown current	4 μ A

Resistor R_{RT} of 57.6k Ω sets the switching frequency at 400kHz. In terms of control loop performance, the target loop crossover frequency is 60kHz with a phase margin greater than 50°. An RSS resistance of 20k Ω sets the output voltage soft-start time to 4.5ms.

Table 8-7 cites the selected buck regulator powertrain components, with many of the components available from multiple vendors. This design uses 80V logic-level MOSFETs, shielded buck inductors, shunt resistors with wide aspect ratio for low ESL, 100V-rated ceramic input capacitors and 25V-rated ceramic output capacitors.

Table 8-7. List of Materials for Application Circuit 3

REFERENCE DESIGNATOR	QTY	SPECIFICATION ⁽¹⁾	MANUFACTURER	PART NUMBER
C _{IN1} , C _{IN2}	8	4.7 μ F, 100V, X7S, 1210, ceramic, AEC-Q200	TDK	CGA6M3X7S2A475K200
			Murata	GCM32DC72A475KE02L
C _{OUT1} , C _{OUT2}	8	22 μ F, 25V, X7R, 1210, ceramic, AEC-Q200	TDK	CGA6P3X7R1E226M250
		22 μ F, 25V, X7S, 1210, ceramic, AEC-Q200	Murata	GCM32EC71E226KE36
L _{O1} , L _{O2}	2	5.6 μ H, 10m Ω , 15A, 10.85 × 10 × 5.2mm, AEC-Q200	Cyntec	VCHW105D-5R6MS5
		5.6 μ H, 14m Ω , 12A, 10.8 × 10 × 5mm, AEC-Q200	Eaton	HCM1A1105V2-5R6-R
		5.6 μ H, 10.2m Ω , 16.2A, 11 × 10 × 5.1mm, AEC-Q200	Bourns	SRP1050WA-5R6M
		4.7 μ H, 13.5m Ω , 16A, 10.85 × 10 × 3.8mm, AEC-Q200	Würth Electronik	784373680047
Q ₁ , Q ₃	2	80V, 13.4m Ω , 8nC, SON 5 × 6, AEC-Q101	onsemi	NVMFS6H852NLT1G
Q ₂ , Q ₄	2	80V, 6.2m Ω , 16nC, SON 5 × 6, AEC-Q101	onsemi	NVMFS6H836NLT1G
R _{S1} , R _{S2}	2	Shunt, 4m Ω ±1%, ±50ppm/°C, 0612 wide aspect ratio, 1.5W, AEC-Q200	Susumu	KRL3216E-C-R004-F
U ₁	1	LM5137-Q1 80V two-phase synchronous buck controller, AEC-Q100	Texas Instruments	LM5137QRHARQ1

8.2.3.2 Detailed Design Procedure

See [Section 8.2.1.2](#).

8.2.3.3 Application Curves

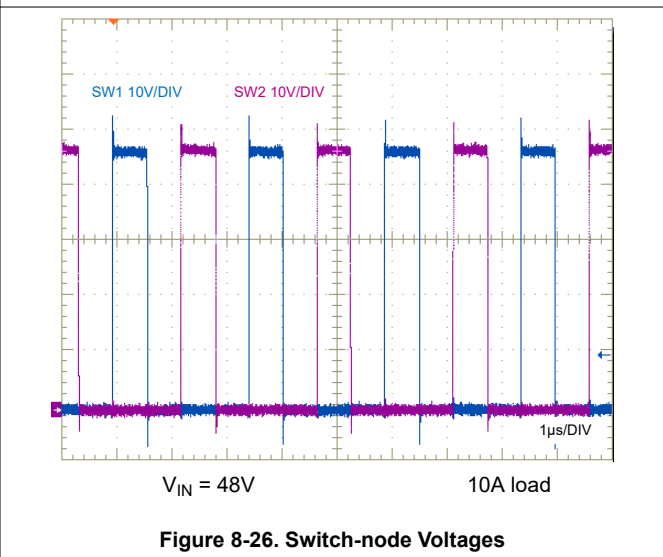
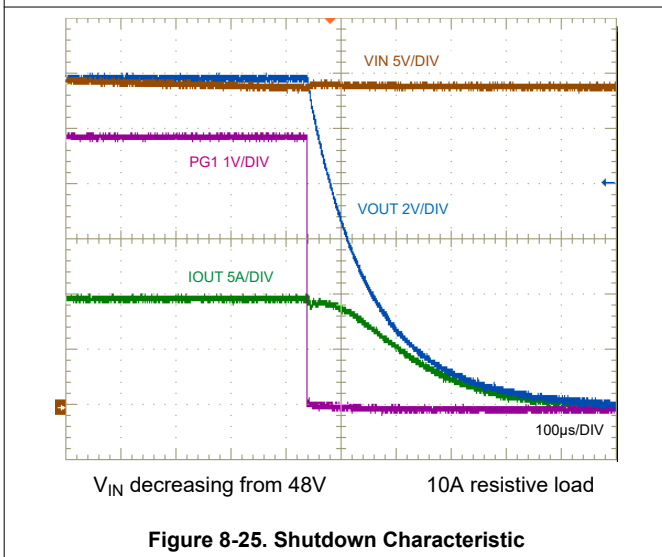
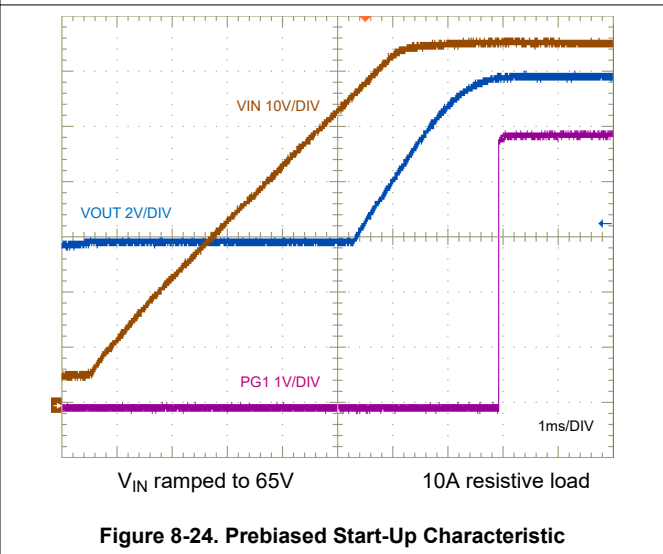
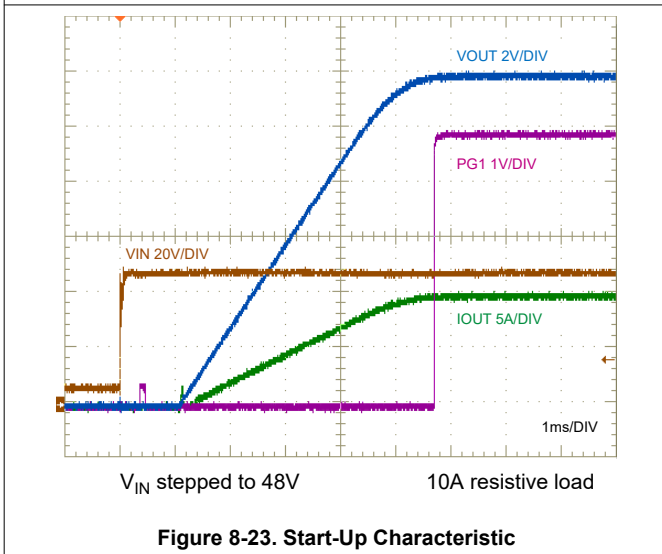
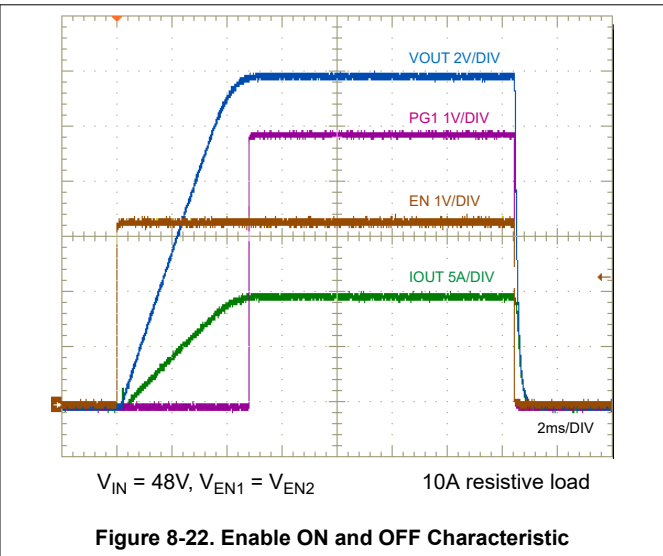
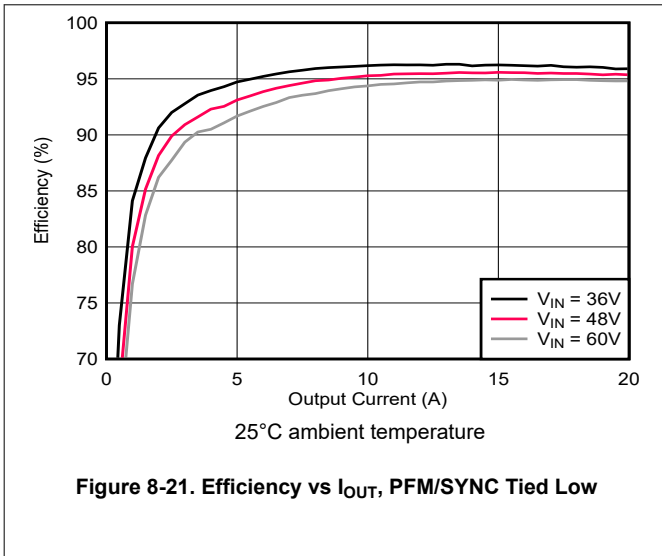

8.2.3.3 Application Curves (continued)

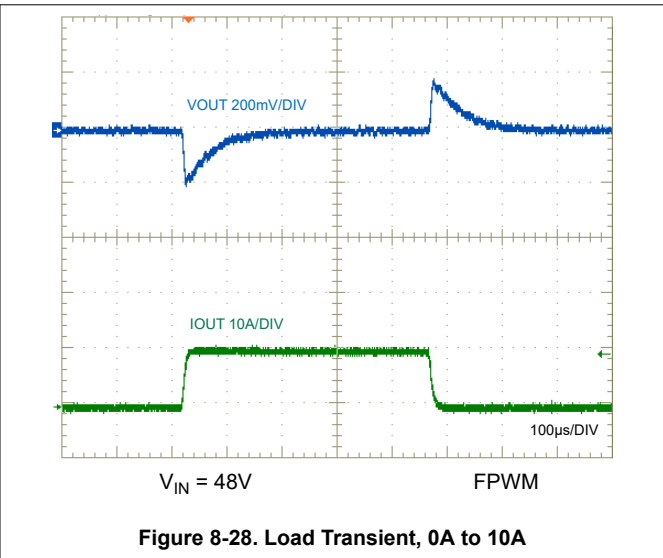
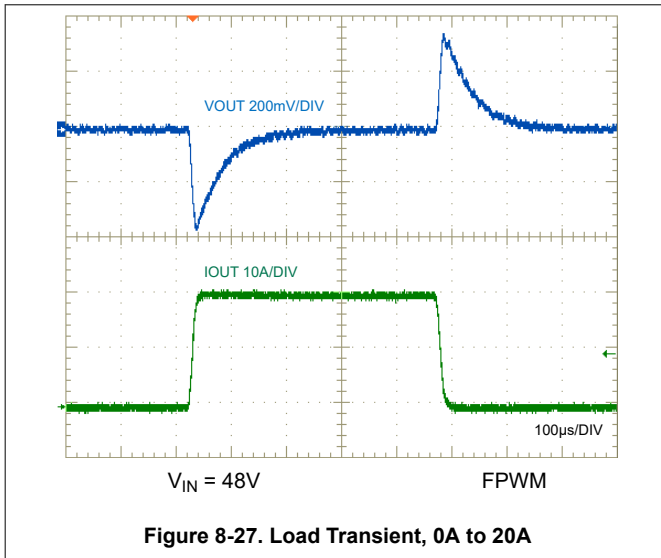

8.3 Power Supply Recommendations

The LM5137-Q1 buck controller is designed to operate from a wide input voltage range of 4V to 80V. The characteristics of the input supply must be compatible with the [Absolute Maximum Ratings](#) and [Recommended Operating Conditions](#) tables. In addition, the input supply must be capable of delivering the required input current to the fully-loaded regulator. Use [Equation 47](#) to estimate the average input current.

$$I_{IN} = \frac{P_{OUT}}{V_{IN} \cdot \eta} \quad (47)$$

where

η is the efficiency.

If the regulator is connected to an input supply through long wires or PCB traces with a large impedance, take special care to achieve stable performance. The parasitic inductance and resistance of the input cables can have an adverse effect on converter operation. The parasitic inductance in combination with the low-ESR ceramic input capacitors form an underdamped resonant circuit. This circuit can cause overvoltage transients at VIN each time the input supply is cycled ON and OFF. The parasitic resistance causes the input voltage to dip during a load transient. The best way to solve such issues is to reduce the distance from the input supply to the regulator and use an aluminum or tantalum input capacitor in parallel with the ceramics. The moderate ESR of the electrolytic capacitors helps to damp the input resonant circuit and reduce any voltage overshoots. A capacitance in the range of 47 μ F to 330 μ F is usually sufficient to provide parallel input damping and helps to hold the input voltage steady during large load transients.

An EMI input filter is often used in front of the regulator that, unless carefully designed, can lead to instability as well as some of the affects mentioned above. The [Simple Success with Conducted EMI for DC-DC Converters application note](#) provides helpful suggestions when designing an input filter for any switching regulator.

8.4 Layout

8.4.1 Layout Guidelines

Proper PCB design and layout is important in a high-current, fast-switching circuit (with high current and voltage slew rates) to achieve a robust and reliable design. As expected, certain issues must be considered before designing a PCB layout using the LM5137-Q1. The high-frequency power loop of a buck regulator power stage is denoted by loop 1 in the shaded area of [Figure 8-29](#). The topological architecture of a buck regulator means that particularly high di/dt current flows in the components of loop 1, and reducing the parasitic inductance of this loop by minimizing the effective loop area becomes mandatory. Also important are the gate drive loops of the high-side and low-side MOSFETs, denoted by 2 and 3, respectively, in [Figure 8-29](#).

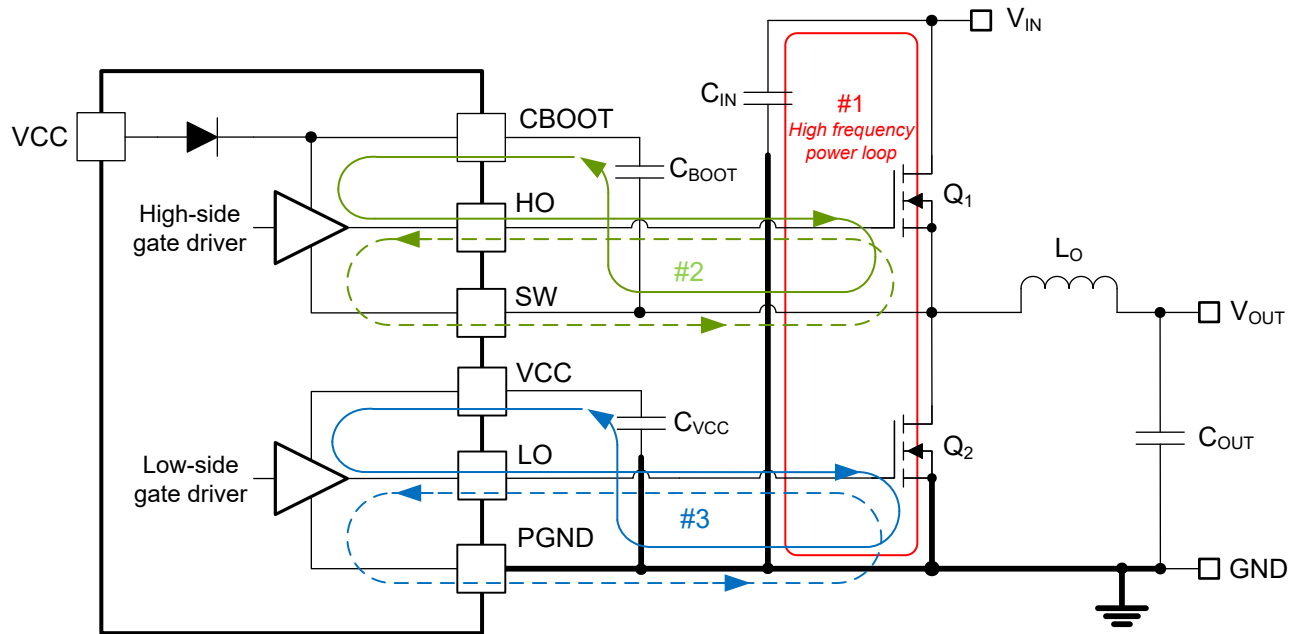

Figure 8-29. DC/DC Regulator Ground System With Power Stage and Gate Drive Circuit Switching Loops

8.4.1.1 Power Stage Layout

- Input capacitors, output capacitors, and MOSFETs are the constituent components of the power stage of a buck regulator and are typically placed on the top side of the PCB (solder side). The benefits of convective heat transfer are maximized because of leveraging any system-level airflow. In a two-sided PCB layout, small-signal components are typically placed on the bottom side (component side). Insert at least one inner plane, connected to ground, to shield and isolate the small-signal traces from noisy power traces and lines.
- The DC/DC regulator has several high-current loops. Minimize the area of these loops to suppress generated switching noise and optimize switching performance.
 - Loop 1: The most important loop area to minimize is the path from the input capacitor or capacitors through the high- and low-side MOSFETs, and back to the capacitor or capacitors through the ground connection. Connect the input capacitor or capacitors negative terminal close to the source of the low-side MOSFET (at ground). Similarly, connect the input capacitor or capacitors positive terminal close to the drain of the high-side MOSFET (at V_{IN}). Refer to "loop 1" in [Figure 8-29](#).
 - Another loop, not as critical as loop 1, is the path from the low-side MOSFET through the inductor and output capacitor or capacitors, and back to source of the low-side MOSFET through ground. Connect the source of the low-side MOSFET and negative terminal of the output capacitor or capacitors at ground as close as possible.
- The PCB trace defined as SW node, which connects to the source of the high-side (control) MOSFET, the drain of the low-side (synchronous) MOSFET and the high-voltage side of the inductor, must be short and wide. However, the SW connection is a source of injected EMI and thus must not be too large.

4. Follow any layout considerations of the MOSFETs as recommended by the MOSFET manufacturer, including pad geometry and solder paste stencil design.
5. The SW pin connects to the switch node of the power conversion stage and acts as the return path for the high-side gate driver. The parasitic inductance inherent to loop 1 in [Figure 8-29](#) and the output capacitance (C_{OSS}) of both power MOSFETs form a resonant circuit that induces high frequency (greater than 50MHz) ringing at the SW node. The voltage peak of this ringing, if not controlled, can be significantly higher than the input voltage. Make sure that the peak ringing amplitude does not exceed the absolute maximum rating limit for the SW pin. In many cases, a series resistor and capacitor snubber network connected from the SW node to GND damps the ringing and decreases the peak amplitude. Provide provisions for snubber network components in the PCB layout. If testing reveals that the ringing amplitude at the SW pin is excessive, then include snubber components as needed.

8.4.1.2 Gate Drive Layout

The LM5137-Q1 high-side and low-side gate drivers incorporate short propagation delays, adaptive deadtime control, and low-impedance output stages capable of delivering large peak currents with very fast rise and fall times to facilitate rapid turn-on and turnoff transitions of the power MOSFETs. Very high di/dt can cause unacceptable ringing if the trace lengths and impedances are not well controlled.

Minimization of stray or parasitic gate loop inductance is key to optimizing gate drive switching performance, whether series gate inductance resonates with MOSFET gate capacitance or common source inductance (common to gate and power loops) that provides a negative feedback component opposing the gate drive command, thereby increasing MOSFET switching times. The following loops are important:

- Loop 2: high-side MOSFET, Q_1 . During the high-side MOSFET turn-on, high current flows from the bootstrap (boot) capacitor through the gate driver and high-side MOSFET, and back to the negative terminal of the boot capacitor through the SW connection. Conversely, to turn off the high-side MOSFET, high current flows from the gate of the high-side MOSFET through the gate driver and SW, and back to the source of the high-side MOSFET through the SW trace. Refer to "loop 2" of [Figure 8-29](#).
- Loop 3: low-side MOSFET, Q_2 . During the low-side MOSFET turn-on, high current flows from the VCC decoupling capacitor through the gate driver and low-side MOSFET, and back to the negative terminal of the capacitor through ground. Conversely, to turn off the low-side MOSFET, high current flows from the gate of the low-side MOSFET through the gate driver and GND, and back to the source of the low-side MOSFET through ground. Refer to "loop 3" of [Figure 8-29](#).

TI strongly recommends following circuit layout guidelines when designing with high-speed MOSFET gate drive circuits.

- Connections from gate driver outputs, HO1/HO2 and LO1/LO2, to the respective gates of the high-side or low-side MOSFETs must be as short as possible to reduce series parasitic inductance. Be aware that peak gate drive currents can be as high as 3A. Use 0.65mm (25mils) or wider traces. Use via or vias, if necessary, of at least 0.5mm (20mils) diameter along these traces. Route the [HO1, SW1] and [HO2, SW2] gate traces as differential pairs from the LM5137-Q1 to the applicable high-side MOSFETs, taking advantage of flux cancellation.
- Minimize the current loop path from the VCC and CBOOT1/CBOOT2 pins through the respective capacitors as these provide the high instantaneous current, up to 3A, to charge the MOSFET gate capacitances. Specifically, locate the bootstrap capacitors, C_{BOOT1} and C_{BOOT2} , close to the respective [CBOOT1, SW1] and [CBOOT2, SW2] pin pairs of the LM5137-Q1, thus minimizing the "loop 2" areas associated with the high-side drivers. Similarly, locate the VCC capacitor, C_{VCC} , close to the VCC and PGND pins of the LM5137-Q1 to minimize the areas of "loop 3" associated with the low-side drivers.

8.4.1.3 PWM Controller Layout

With the proviso to locate the controller close to the power MOSFETs and minimize gate driver trace runs, the following considers components related to the analog and feedback signals as well as current sensing:

1. Separate power and signal traces, and use a ground plane to provide noise shielding.
2. Place all sensitive analog traces and components related to COMP1/2, FB1/2, ISNS1/2+, RSS, and RT away from high-voltage switching nodes such as SW1/2, HO1/2, LO1/2 or CBOOT1/2 to avoid mutual

coupling. Use internal layers as ground planes. Pay particular attention to shielding the feedback (FB) trace from power traces and components.

3. Locate the upper and lower feedback resistors (if required) close to the respective FB pins, keeping the FB traces as short as possible. Route the trace from the upper feedback resistors to the required output voltage sense points at the loads.
4. Route the [ISNS1+, BIAS1/VOUT1] and [ISNS2+, VOUT1/2] traces as differential pairs to minimize noise pickup and use Kelvin connections to the applicable shunt resistor (if shunt current sensing is used) or to the sense capacitor (if inductor DCR current sensing is used). In particular, *use a wide trace for the connection to BIAS1/VOUT1*, preferably 80mils (2mm), to minimize the voltage drop related to bias current flowing to that pin affecting the current sense.
5. Minimize the loop area from the VCC and VIN pins through the respective decoupling capacitors to the PGND pin. Locate these capacitors as close as possible to the LM5137-Q1.

8.4.1.4 Thermal Design and Layout

The useful operating temperature range of a PWM controller with integrated gate drivers and bias supply LDO regulator is greatly affected by the following:

- Average gate drive current requirements of the power MOSFETs
- Switching frequency
- Operating input voltage (affecting bias regulator LDO voltage drop and hence the power dissipation)
- Thermal characteristics of the package and operating environment

For a PWM controller to be useful over a particular temperature range, the package must allow for the efficient removal of the heat produced while keeping the junction temperature within rated limits. The LM5137-Q1 controller is available in a small 6mm × 6mm 36-pin VQFN (RHA) PowerPAD package to cover a range of application requirements. [Thermal Information](#) summarizes the thermal metrics of this package.

The 36-pin VQFN package offers a means of removing heat from the semiconductor die through the exposed thermal pad at the base of the package. While the exposed pad of the package is not directly connected to any leads of the package, exposed pad of the package is thermally connected to the substrate of the LM5137-Q1 device (ground). This connection allows a significant improvement in heat sinking, and designing the PCB with thermal lands, thermal vias, and a ground plane to complete the heat removal subsystem is imperative. The exposed pad of the LM5137-Q1 is soldered to the ground-connected copper land on the PCB directly underneath the device package, reducing the thermal resistance to a very low value.

Numerous vias with a 0.3mm diameter connected from the thermal land to the internal and solder-side ground plane or planes are vital to help dissipation. In a multi-layer PCB design, a solid ground plane is typically placed on the PCB layer below the power components. Not only does this action provide a plane for the power stage currents to flow but this action also represents a thermally conductive path away from the heat generating devices.

The thermal characteristics of the MOSFETs also are significant. The drain pads of the high-side MOSFETs are normally connected to a VIN plane for heat sinking. The drain pads of the low-side MOSFETs are tied to the respective SW planes, but the SW plane area is purposely kept as small as possible to mitigate EMI concerns.

8.4.1.5 Ground Plane Design

As mentioned previously, TI recommends using one or more of the inner PCB layers as a solid ground plane. A ground plane offers shielding for sensitive circuits and traces and also provides a quiet reference potential for the control circuitry. Connect the PGND pin of the LM5137-Q1 to the system ground plane using an array of vias under the exposed pad. Also connect the PGND copper directly to the return terminals of the input and output capacitors. The PGND nets contain noise at the switching frequency and can bounce because of load current variations. The power traces (polygons) to the power-stage components for PGND, VIN and SW1/SW2 can be restricted to one side of the ground plane. The other side of the ground plane contains much less noise and is an excellent choice for sensitive analog trace routes.

8.4.2 Layout Example

Based on the [LM25137F-Q1-EVM5D3](#) design, [Figure 8-30](#) shows a single-sided layout of a dual-output synchronous buck regulator. The design uses layer 2 of the PCB as a power-loop ground return path directly underneath the top layer to create a low-area switching power loop of approximately 2mm². This loop area must be as small as possible to minimize power-loop parasitic inductance, which results in reduced switch-node voltage overshoot and ringing (and hence an improved overall EMI signature). See also the [LM25137F-Q1-EVM5D3 Evaluation Module](#) and [LM5137F-Q1-EVM12V Evaluation Module](#) EVM user's guides.

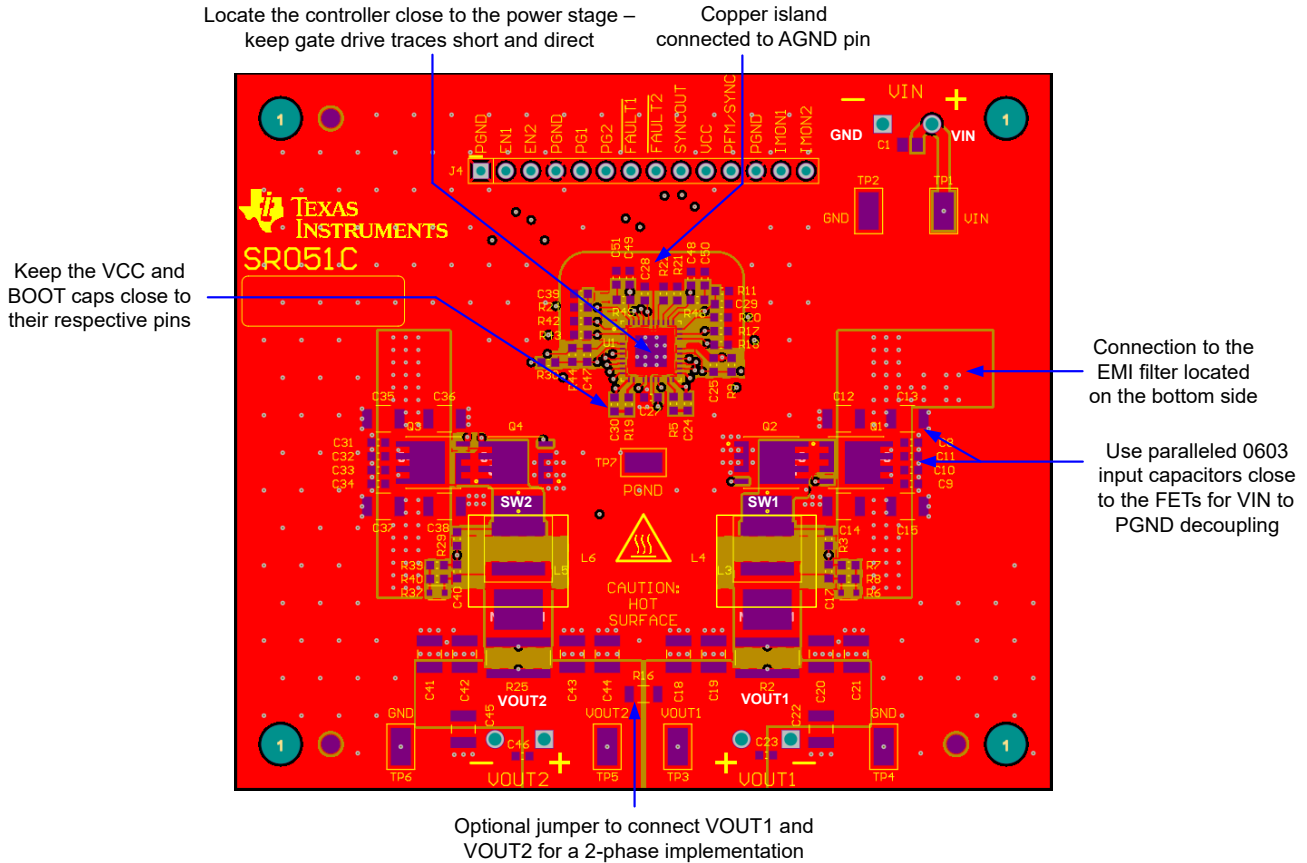

Figure 8-30. PCB Top Layer

As shown in [Figure 8-31](#), the high-frequency power loop current flows through MOSFETs Q3 and Q4, through the power ground plane on layer 2, and back to VIN through the 0603 ceramic capacitors C30 through C33. The currents flowing in opposing directions in the vertical loop configuration provide field self-cancellation, reducing parasitic loop inductance. [Figure 8-32](#) shows a side view to illustrate the concept of creating a low-profile, self-canceling loop in a multilayer PCB structure. The layer-2 GND plane layer, shown in [Figure 8-31](#), provides a tightly-coupled current return path directly under the MOSFETs to the source terminals of Q4.

Four 10nF input capacitors with small 0603 case size, place in parallel close to the drain of each high-side MOSFET. The low ESL and high self-resonant frequency (SRF) of the small footprint capacitors yield excellent high-frequency performance. The negative terminals of these capacitors connect to the layer-2 GND plane with multiple 12mil (0.3mm) diameter vias, further reducing parasitic inductance.

Additional steps used in this layout example include:

- Keep the SW connection from the power MOSFETs to the inductor (for each channel) at minimum copper area to reduce capacitive coupling and radiated EMI.
- Locate the IC close to the power MOSFETs and keep the gate drive traces short and direct. Route the HO and SW traces as a diff pair and run the LO trace above or below a ground plane.

LM5137-Q1

SNVSCU2B – AUGUST 2024 – REVISED AUGUST 2025

- Create an analog ground plane near the IC for sensitive analog components. Connect the AGND plane and the PGND power ground planes at a single point at the die attach pad (DAP) of the IC.
- Increase the width of the BIAS1/VOUT1 trace to minimize the voltage offset related to VCC bias current, as shown in Figure 8-33.

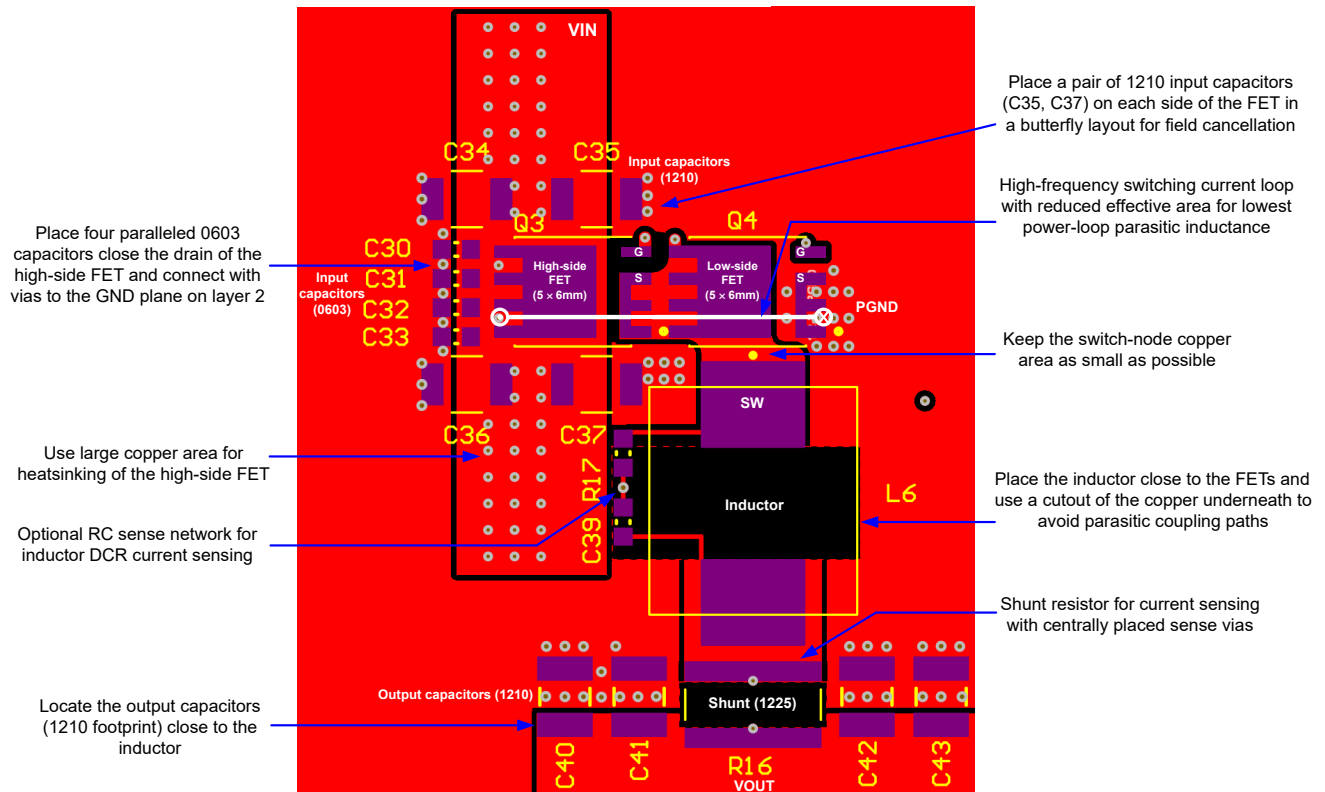
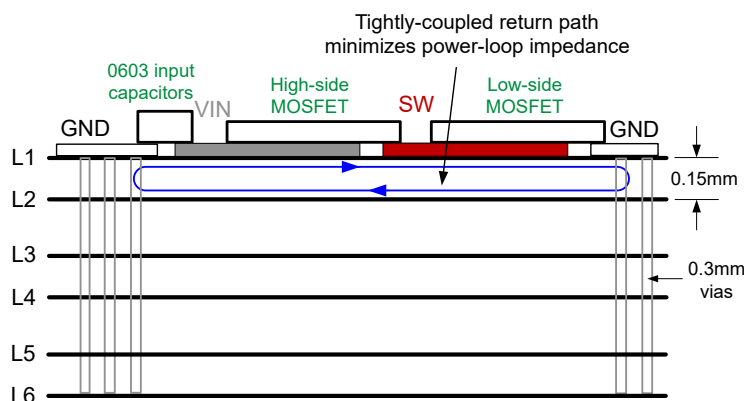

Figure 8-31. Power Stage Component Layout



See the [Improve High-current DC/DC Regulator Performance for Free with Optimized Power Stage Layout](#) application brief for more detail.

Figure 8-32. PCB Stack-Up Diagram With Low L1-L2 Intra-layer Spacing

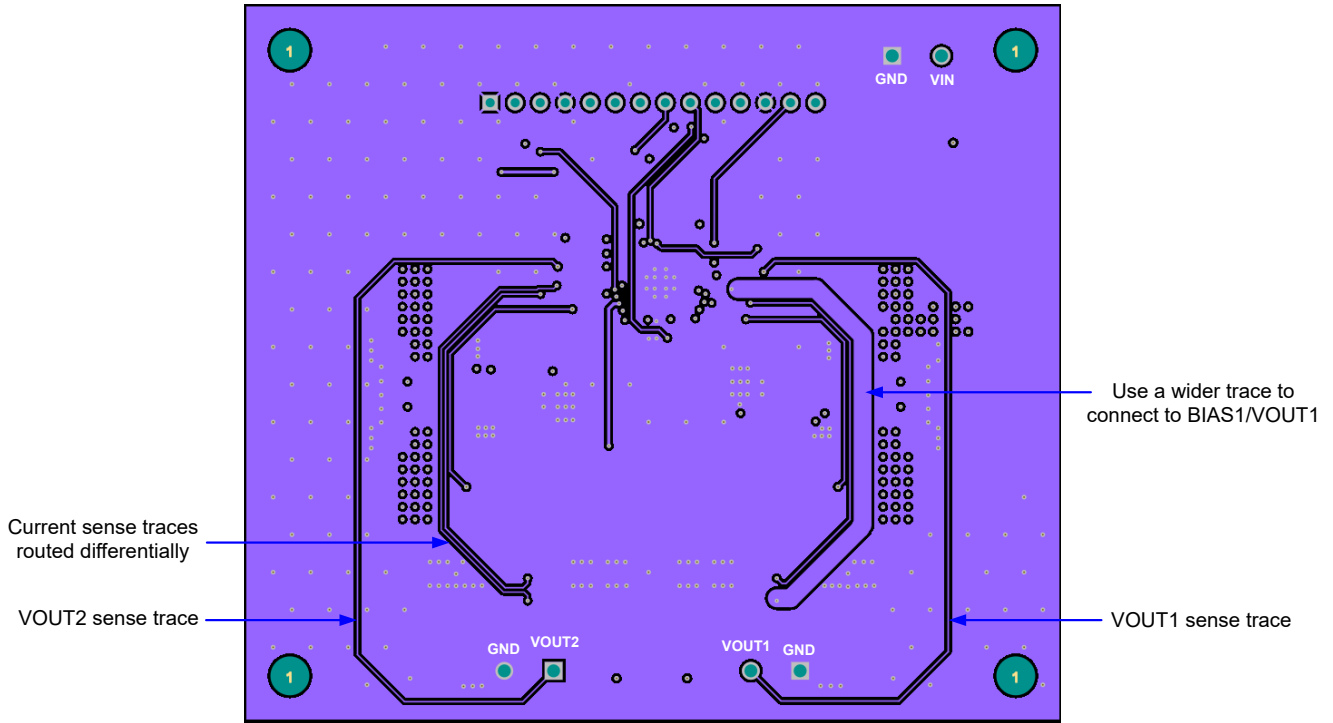

Figure 8-33. PCB Inner Layer

9 Device and Documentation Support

9.1 Device Support

9.1.1 Third-Party Products Disclaimer

TI'S PUBLICATION OF INFORMATION REGARDING THIRD-PARTY PRODUCTS OR SERVICES DOES NOT CONSTITUTE AN ENDORSEMENT REGARDING THE SUITABILITY OF SUCH PRODUCTS OR SERVICES OR A WARRANTY, REPRESENTATION OR ENDORSEMENT OF SUCH PRODUCTS OR SERVICES, EITHER ALONE OR IN COMBINATION WITH ANY TI PRODUCT OR SERVICE.

9.1.2 Development Support

With an input operating voltage as low as 3.5V and up to 100V as specified in [Table 9-1](#), the LM(2)5k-Q1 family of automotive synchronous buck controllers from TI provides flexibility, scalability and optimized design size for a variety of applications.

With the LM5137F-Q1 and LM25137F-Q1 available to aid in functional safety system design up to ASIL D, the controller family enables DC/DC designs with high density, low EMI, and increased system reliability. All controllers are rated for a maximum operating junction temperature of 150°C and have AEC-Q100 grade 1 qualification.

Table 9-1. Automotive Synchronous Buck DC/DC Controller Family

DC/DC CONTROLLER	SINGLE or DUAL	V _{IN} RANGE	CONTROL METHOD	GATE DRIVE VOLTAGE	SYNC OUTPUT	KEY FEATURE
LM5137-Q1	Dual	4V to 80V	Peak current mode	5V	90° phase shift	100% duty cycle
LM5137F-Q1	Dual	4V to 80V	Peak current mode	5V	90° phase shift	ASIL B or D
LM25137-Q1	Dual	4V to 42V	Peak current mode	5V	90° phase shift	100% duty cycle
LM25137F-Q1	Dual	4V to 42V	Peak current mode	5V	90° phase shift	ASIL B or D
LM25139-Q1	Single	4V to 42V	Peak current mode	5V	N/A	DRSS
LM5141-Q1	Single	3.8V to 65V	Peak current mode	5V	N/A	Split gate drive
LM25141-Q1	Single	3.8V to 42V	Peak current mode	5V	N/A	Split gate drive
LM5143A-Q1	Dual	3.5V to 65V	Peak current mode	5V	90° phase shift	Split gate drive
LM25143-Q1	Dual	3.5V to 42V	Peak current mode	5V	90° phase shift	Split gate drive
LM5145-Q1	Single	5.5V to 75V	Voltage mode	7.5V	180° phase shift	No shunt
LM5146-Q1	Single	5.5V to 100V	Voltage mode	7.5V	180° phase shift	100V input capability
LM5148-Q1	Single	3.5V to 80V	Peak current mode	5V	180° phase shift	DRSS
LM25148-Q1	Single	3.5V to 42V	Peak current mode	5V	180° phase shift	DRSS
LM5149-Q1	Single	3.5V to 80V	Peak current mode	5V	180° phase shift	AEF
LM25149-Q1	Single	3.5V to 42V	Peak current mode	5V	180° phase shift	AEF
LM5190-Q1	Single	5V to 80V	Peak current mode	7.5V	N/A	CC/CV
LM25190-Q1	Single	5V to 42V	Peak current mode	7.5V	N/A	CC/CV

For development support, see the following:

- [LM5137-Q1 DC/DC controller Quickstart Calculator](#) and [PSPICE](#) simulation models
- [LM5137F-Q1-EVM12V](#) and [LM25137F-Q1-EVM5D3 Altium layout source](#) files
- For TI's WEBENCH design environments, visit the [WEBENCH® Design Center](#)
- For TI's reference design library, visit [TI Designs](#)
- TI reference designs:
 - [450W four-phase interleaved buck converter reference design](#)

9.1.2.1 Custom Design With WEBENCH® Tools

[Click here](#) to create a custom design using the LM5137-Q1 device with the WEBENCH® Power Designer.

1. Start by entering the input voltage (V_{IN}), output voltage (V_{OUT}), and output current (I_{OUT}) requirements.

2. Optimize the design for key parameters such as efficiency, footprint, and cost using the optimizer dial.
3. Compare the generated design with other possible solutions from Texas Instruments.

The WEBENCH Power Designer gives a customized schematic along with a list of materials with real-time pricing and component availability.

In most cases, these actions are available:

- Run electrical simulations to see important waveforms and circuit performance
- Run thermal simulations to understand board thermal performance
- Export customized schematic and layout into popular CAD formats
- Print PDF reports for the design, and share the design with colleagues

Get more information about WEBENCH tools at www.ti.com/WEBENCH.

9.2 Documentation Support

9.2.1 Related Documentation

For related documentation, see the following:

- User's guides:
 - Texas Instruments, [LM5137F-Q1 12V, 20A Single-Output Evaluation Module](#)
 - Texas Instruments, [LM25137F-Q1 5V and 3.3V Dual-Output Evaluation Module](#)
 - Texas Instruments, [LM5143-Q1 EVM User's Guide](#)
 - Texas Instruments, [LM5141-Q1 EVM User's Guide](#)
 - Texas Instruments, [LM5146-Q1 EVM User's Guide](#)
 - Texas Instruments, [LM5145EVM-HD-20A High Density Evaluation Module](#)
 - Texas Instruments, [LM5149-Q1 Buck Converter Evaluation Module User's Guide](#)
 - Texas Instruments, [LM5190-Q1 CC-CV Buck Controller Evaluation Module](#)
- Application notes:
 - Texas Instruments, [How to Implement a Four-Phase Interleaving Buck With the LM5137F-Q1](#)
 - Texas Instruments, [LM5143-Q1 4-phase Buck Regulator Design for Automotive ADAS Applications](#)
- Technical articles:
 - Texas Instruments, [Achieving functional safety compliance in automotive off-battery buck preregulator designs](#)
 - Texas Instruments, [Powering next-generation ADAS processors with TI Functional Safety-Compliant buck regulators](#)

9.2.1.1 Low-EMI Design Resources

- Texas Instruments, [Low EMI landing page](#)
- Texas Instruments, [Tackling the EMI challenge](#) company blog
- Texas Instruments, [An Engineer's Guide to Low EMI in DC/DC Regulators](#) e-book
- Texas Instruments, [Designing a low-EMI power supply](#) video series
- White papers:
 - Texas Instruments, [An Overview of Conducted EMI Specifications for Power Supplies](#)
 - Texas Instruments, [An Overview of Radiated EMI Specifications for Power Supplies](#)
 - Texas Instruments, [Time-Saving and Cost-Effective Innovations for EMI Reduction in Power Supplies](#)
 - Texas Instruments, [Valuing Wide \$V_{IN}\$, Low EMI Synchronous Buck Circuits for Cost-driven, Demanding Applications](#)
- Texas Instruments, [Improve High-Current DC/DC Regulator EMI for Free With Optimized Power Stage Layout application brief](#)
- Texas Instruments, [Reduce Buck Converter EMI and Voltage Stress by Minimizing Inductive Parasitics analog design journal](#)

9.2.1.2 Thermal Design Resources

- White paper:
 - Texas Instruments, [Improving Thermal Performance in High Ambient Temperature Environments With Thermally Enhanced Packaging](#)
- Applications notes:
 - Texas Instruments, [Thermal Design by Insight, Not Hindsight](#)
 - Texas Instruments, [A Guide to Board Layout for Best Thermal Resistance for Exposed Pad Packages](#)
 - Texas Instruments, [Semiconductor and IC Package Thermal Metrics](#)
 - Texas Instruments, [PowerPAD™ Thermally Enhanced Package](#)
 - Texas Instruments, [Using New Thermal Metrics](#)
- Application brief:
 - Texas Instruments, [PowerPAD™ Made Easy](#)

9.2.1.3 PCB Layout Resources

- LM5137F-Q1-EVM12V and LM25137F-Q1-EVM5D3 [Altium layout](#) source files
- Applications notes:
 - Texas Instruments, [AN-1149 Layout Guidelines for Switching Power Supplies](#)
- Application brief:
 - Texas Instruments, [Improve High-Current DC/DC Regulator EMI Performance for Free With Optimized Power Stage Layout](#)
- Seminar:
 - Texas Instruments, [Constructing Your Power Supply – Layout Considerations](#)

9.3 Receiving Notification of Documentation Updates

To receive notification of documentation updates, navigate to the device product folder on [ti.com](#). Click on *Notifications* to register and receive a weekly digest of any product information that has changed. For change details, review the revision history included in any revised document.

9.4 Support Resources

[TI E2E™ support forums](#) are an engineer's go-to source for fast, verified answers and design help — straight from the experts. Search existing answers or ask your own question to get the quick design help you need.

Linked content is provided "AS IS" by the respective contributors. They do not constitute TI specifications and do not necessarily reflect TI's views; see TI's [Terms of Use](#).

9.5 Trademarks

PowerPAD™ and TI E2E™ are trademarks of Texas Instruments.

WEBENCH® is a registered trademark of Texas Instruments.

All trademarks are the property of their respective owners.

9.6 Electrostatic Discharge Caution



This integrated circuit can be damaged by ESD. Texas Instruments recommends that all integrated circuits be handled with appropriate precautions. Failure to observe proper handling and installation procedures can cause damage.

ESD damage can range from subtle performance degradation to complete device failure. Precision integrated circuits may be more susceptible to damage because very small parametric changes could cause the device not to meet its published specifications.

9.7 Glossary

[TI Glossary](#)

This glossary lists and explains terms, acronyms, and definitions.

10 Revision History

NOTE: Page numbers for previous revisions may differ from page numbers in the current version.

Changes from Revision A (August 2024) to Revision B (August 2025)	Page
• Changed the document status from Advance Information to Production Data.....	1

11 Mechanical, Packaging, and Orderable Information

The following pages show mechanical, packaging, and orderable information. This information is the most current data available for the designated devices. This data is subject to change without notice and revision of this document. For browser-based versions of this data sheet, refer to the left-hand navigation.

PACKAGING INFORMATION

Orderable part number	Status (1)	Material type (2)	Package Pins	Package qty Carrier	RoHS (3)	Lead finish/ Ball material (4)	MSL rating/ Peak reflow (5)	Op temp (°C)	Part marking (6)
LM5137QRHARQ1	Active	Production	VQFN (RHA) 36	2500 LARGE T&R	Yes	NIPDAU	Level-2-260C-1 YEAR	-40 to 150	5137Q RHARQ1

(1) **Status:** For more details on status, see our [product life cycle](#).

(2) **Material type:** When designated, preproduction parts are prototypes/experimental devices, and are not yet approved or released for full production. Testing and final process, including without limitation quality assurance, reliability performance testing, and/or process qualification, may not yet be complete, and this item is subject to further changes or possible discontinuation. If available for ordering, purchases will be subject to an additional waiver at checkout, and are intended for early internal evaluation purposes only. These items are sold without warranties of any kind.

(3) **RoHS values:** Yes, No, RoHS Exempt. See the [TI RoHS Statement](#) for additional information and value definition.

(4) **Lead finish/Ball material:** Parts may have multiple material finish options. Finish options are separated by a vertical ruled line. Lead finish/Ball material values may wrap to two lines if the finish value exceeds the maximum column width.

(5) **MSL rating/Peak reflow:** The moisture sensitivity level ratings and peak solder (reflow) temperatures. In the event that a part has multiple moisture sensitivity ratings, only the lowest level per JEDEC standards is shown. Refer to the shipping label for the actual reflow temperature that will be used to mount the part to the printed circuit board.

(6) **Part marking:** There may be an additional marking, which relates to the logo, the lot trace code information, or the environmental category of the part.

Multiple part markings will be inside parentheses. Only one part marking contained in parentheses and separated by a "-" will appear on a part. If a line is indented then it is a continuation of the previous line and the two combined represent the entire part marking for that device.

Important Information and Disclaimer: The information provided on this page represents TI's knowledge and belief as of the date that it is provided. TI bases its knowledge and belief on information provided by third parties, and makes no representation or warranty as to the accuracy of such information. Efforts are underway to better integrate information from third parties. TI has taken and continues to take reasonable steps to provide representative and accurate information but may not have conducted destructive testing or chemical analysis on incoming materials and chemicals. TI and TI suppliers consider certain information to be proprietary, and thus CAS numbers and other limited information may not be available for release.

In no event shall TI's liability arising out of such information exceed the total purchase price of the TI part(s) at issue in this document sold by TI to Customer on an annual basis.

OTHER QUALIFIED VERSIONS OF LM5137-Q1 :

- Catalog : [LM5137](#)

NOTE: Qualified Version Definitions:

- Catalog - TI's standard catalog product

TAPE AND REEL INFORMATION

QUADRANT ASSIGNMENTS FOR PIN 1 ORIENTATION IN TAPE

*All dimensions are nominal

Device	Package Type	Package Drawing	Pins	SPQ	Reel Diameter (mm)	Reel Width W1 (mm)	A0 (mm)	B0 (mm)	K0 (mm)	P1 (mm)	W (mm)	Pin1 Quadrant
LM5137QRHARQ1	VQFN	RHA	36	2500	330.0	16.4	6.3	6.3	1.1	12.0	16.0	Q2

TAPE AND REEL BOX DIMENSIONS

*All dimensions are nominal

Device	Package Type	Package Drawing	Pins	SPQ	Length (mm)	Width (mm)	Height (mm)
LM5137QRHARQ1	VQFN	RHA	36	2500	367.0	367.0	38.0

GENERIC PACKAGE VIEW

RHA 36

VQFN - 1 mm max height

6 x 6, 0.5 mm pitch

PLASTIC QUAD FLATPACK - NO LEAD

This image is a representation of the package family, actual package may vary.
Refer to the product data sheet for package details.

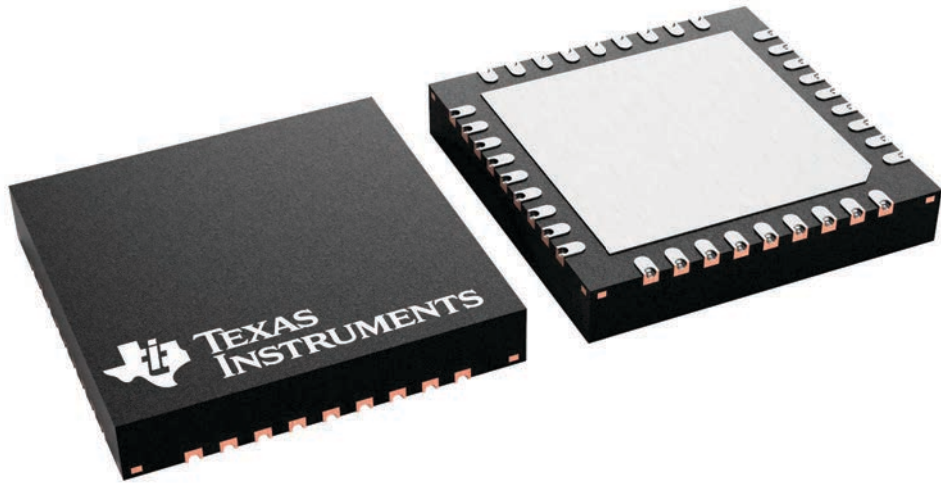

4228438/A

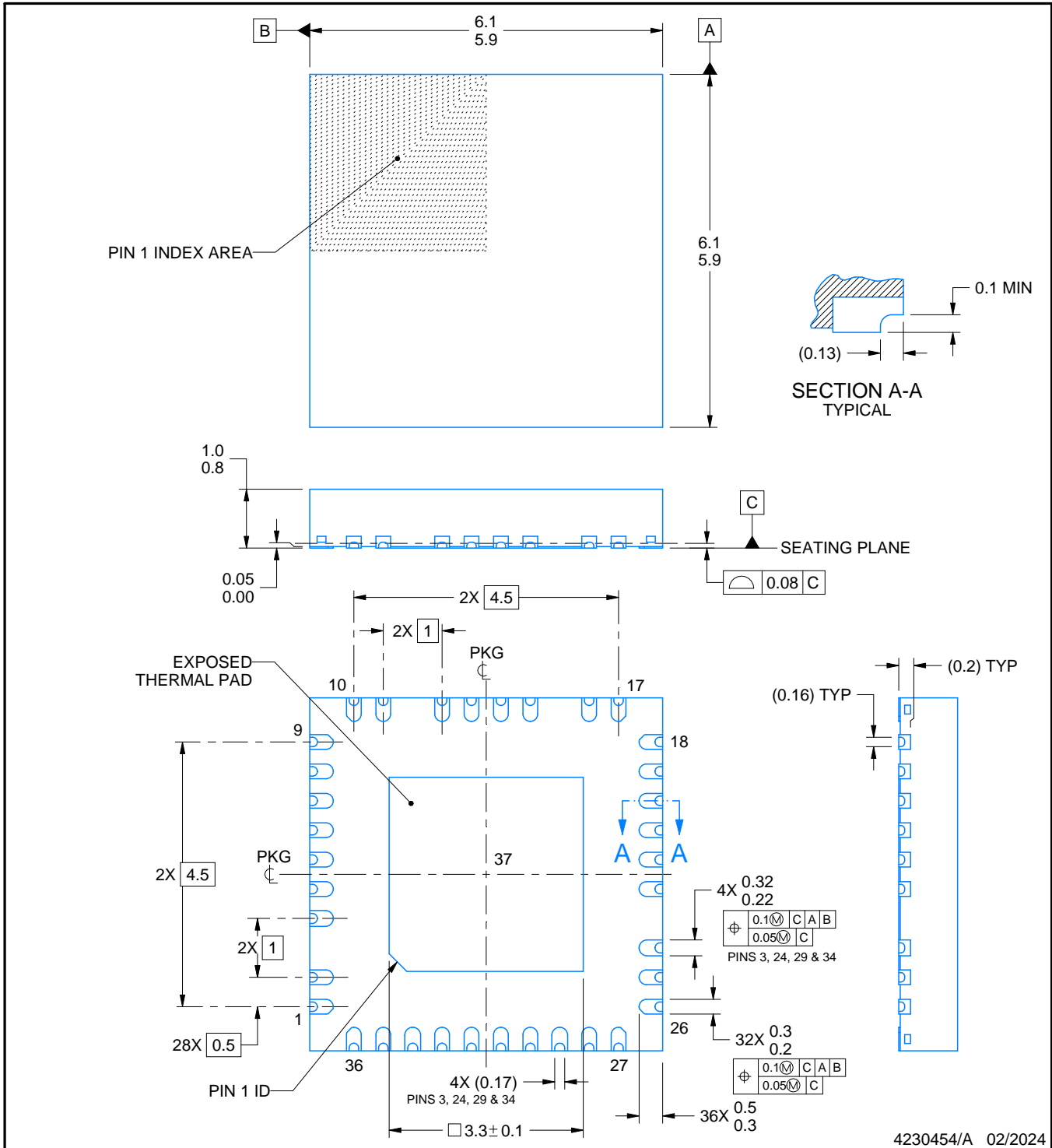
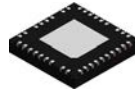

NOTES:

1. All linear dimensions are in millimeters. Any dimensions in parenthesis are for reference only. Dimensioning and tolerancing per ASME Y14.5M.
2. This drawing is subject to change without notice.
3. The package thermal pad must be soldered to the printed circuit board for thermal and mechanical performance.

EXAMPLE BOARD LAYOUT

RHA0036D

VQFN - 1 mm max height

PLASTIC QUAD FLATPACK - NO LEAD

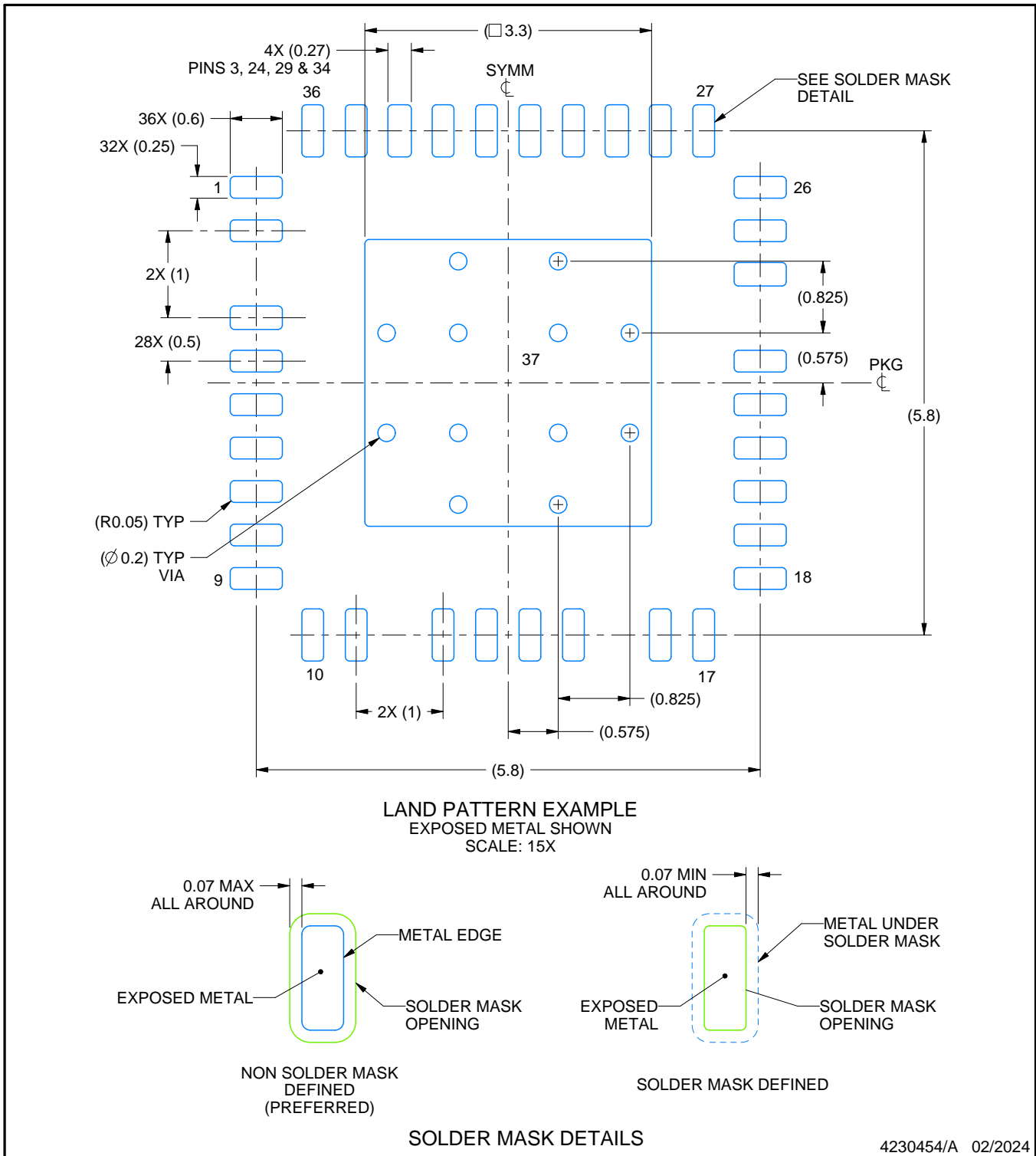

4230454/A 02/2024

NOTES: (continued)

- This package is designed to be soldered to a thermal pad on the board. For more information, see Texas Instruments literature number SLUA271 (www.ti.com/lit/slua271).
- Vias are optional depending on application, refer to device data sheet. If any vias are implemented, refer to their locations shown on this view. It is recommended that vias under paste be filled, plugged or tented.

EXAMPLE STENCIL DESIGN

RHA0036D

VQFN - 1 mm max height

PLASTIC QUAD FLATPACK - NO LEAD

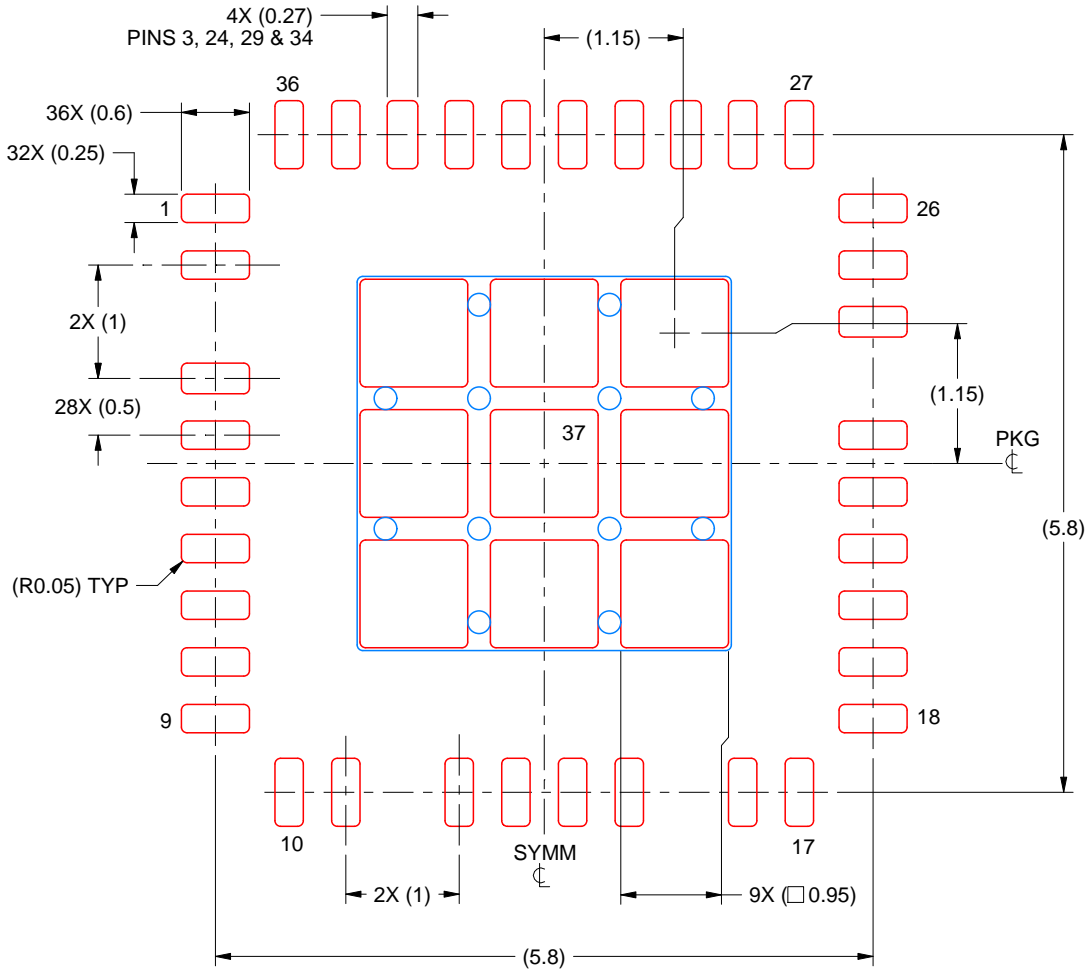

SOLDER PASTE EXAMPLE
 BASED ON 0.125 MM THICK STENCIL
 SCALE: 15X

EXPOSED PAD 37
 75% PRINTED SOLDER COVERAGE BY AREA UNDER PACKAGE

4230454/A 02/2024

NOTES: (continued)

6. Laser cutting apertures with trapezoidal walls and rounded corners may offer better paste release. IPC-7525 may have alternate design recommendations.

IMPORTANT NOTICE AND DISCLAIMER

TI PROVIDES TECHNICAL AND RELIABILITY DATA (INCLUDING DATASHEETS), DESIGN RESOURCES (INCLUDING REFERENCE DESIGNS), APPLICATION OR OTHER DESIGN ADVICE, WEB TOOLS, SAFETY INFORMATION, AND OTHER RESOURCES "AS IS" AND WITH ALL FAULTS, AND DISCLAIMS ALL WARRANTIES, EXPRESS AND IMPLIED, INCLUDING WITHOUT LIMITATION ANY IMPLIED WARRANTIES OF MERCHANTABILITY, FITNESS FOR A PARTICULAR PURPOSE OR NON-INFRINGEMENT OF THIRD PARTY INTELLECTUAL PROPERTY RIGHTS.

These resources are intended for skilled developers designing with TI products. You are solely responsible for (1) selecting the appropriate TI products for your application, (2) designing, validating and testing your application, and (3) ensuring your application meets applicable standards, and any other safety, security, regulatory or other requirements.

These resources are subject to change without notice. TI grants you permission to use these resources only for development of an application that uses the TI products described in the resource. Other reproduction and display of these resources is prohibited. No license is granted to any other TI intellectual property right or to any third party intellectual property right. TI disclaims responsibility for, and you fully indemnify TI and its representatives against any claims, damages, costs, losses, and liabilities arising out of your use of these resources.

TI's products are provided subject to [TI's Terms of Sale](#), [TI's General Quality Guidelines](#), or other applicable terms available either on ti.com or provided in conjunction with such TI products. TI's provision of these resources does not expand or otherwise alter TI's applicable warranties or warranty disclaimers for TI products. Unless TI explicitly designates a product as custom or customer-specified, TI products are standard, catalog, general purpose devices.

TI objects to and rejects any additional or different terms you may propose.

Copyright © 2026, Texas Instruments Incorporated

Last updated 10/2025