

LM5137F-Q1 Automotive, 4V to 80V, 100% Duty Cycle Capable, Dual-Channel Synchronous Buck Controller Family for Functional Safety Applications

1 Features

- AEC-Q100 qualified for automotive applications:
 - Device temperature grade 1: -40°C to 125°C ambient operating temperature
- **Functional Safety-Compliant**
 - Developed for functional safety applications
 - Three [orderable part numbers](#) for Capable, ASIL B, and ASIL D options
 - Documentation available to aid ISO 26262 system design up to ASIL D
 - Systematic capability up to ASIL D
 - Hardware integrity up to ASIL D
- Versatile dual synchronous buck DC/DC controller
 - Wide input voltage range of 4V to 80V
 - 1% accurate, fixed 3.3V, 5V, 12V, or adjustable outputs from 0.8V to 60V
 - Current monitor output for each channel
 - Charge-pump gate drivers for 100% duty cycle
 - No-load sleep current of $13\mu\text{A}$ (typical)
 - Internal hiccup-mode overcurrent protection
- Two interleaved synchronous buck channels
 - Dual channel or single-output multiphase
 - Stackable up to four phases
- Designed for ultra-low EMI requirements
 - Dual Random Spread Spectrum (DRSS)
 - Switching frequency from 100kHz to 2.5MHz
- VQFN-36 [package](#) with wettable flanks
- Create a custom design using the LM5137F-Q1 with [WEBENCH® Power Designer](#)

2 Applications

- [48V in automotive, body electronics and lighting](#)
- [Infotainment and cluster, ADAS](#)
- [High-voltage](#) battery-operated systems

3 Description

The LM5137F-Q1 is an 80V, dual-channel, buck controller offered from a family with three [options](#) for functional safety: Capable, ASIL B, or ASIL D. The device uses an interleaved, stackable, peak current-mode architecture for easy loop compensation, fast transient response, excellent load and line regulation, and accurate current sharing with paralleled phases for high output current. A high-side switch minimum on-time of 22ns facilitates large step-down ratios, enabling the direct conversion from 12V, 24V, or 48V automotive inputs to low-voltage rails for reduced system design cost and complexity. The LM5137F-Q1 continues operating during input voltage dips as low as 4V, at 100% duty cycle if needed.

Package Information

PART NUMBER	PACKAGE ⁽¹⁾	PACKAGE SIZE ⁽²⁾
LM5137F-Q1	RHA (VQFN, 36)	6.0mm × 6.0mm

- (1) For more information, see [Section 7](#).
- (2) The package size (length × width) is a nominal value and includes pins, where applicable.

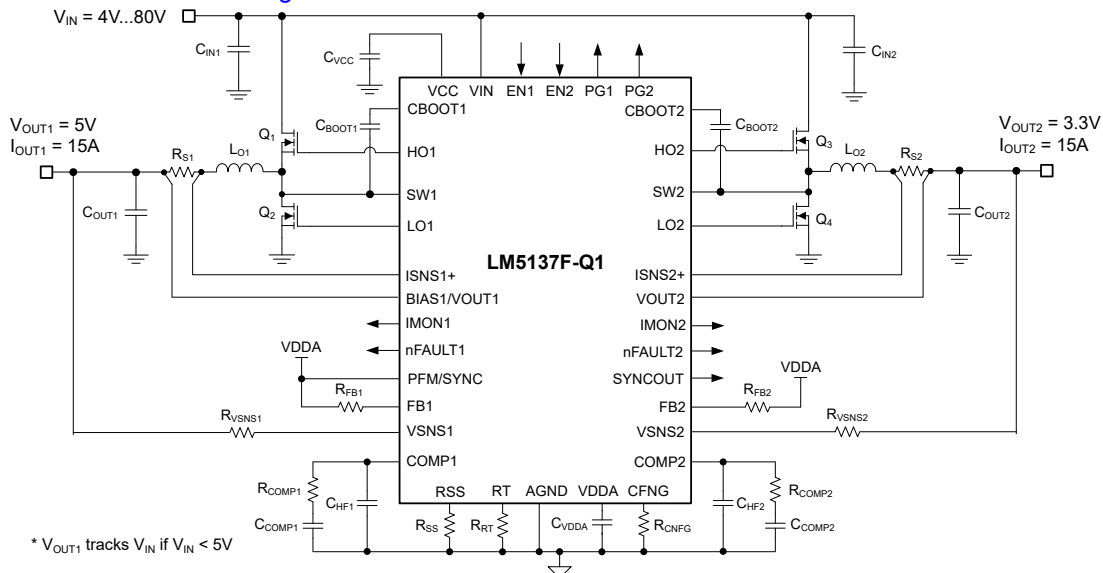

LM5137F-Q1 Dual-Output Buck Switching Regulator – Simplified Schematic



Several features are included to simplify compliance with CISPR 25 and automotive EMI requirements. Adaptively timed, high-current MOSFET gate drivers minimize body diode conduction during switching transitions, reducing switching losses and improving thermal and EMI performance at high input voltage and high switching frequency. To reduce input capacitor ripple current and EMI filter size, 180° interleaved operation is provided for two outputs. A 90° out-of-phase clock output works well for cascaded, multi-channel or multiphase power stages. Resistor-adjustable switching frequency as high as 2.2MHz can be synchronized to an external clock source up to 2.5MHz to eliminate beat frequencies in noise-sensitive applications.

The 13µA no-load quiescent current with the output voltage in regulation extends operating run-time in battery-powered automotive systems. Additional features of the LM5137F-Q1 include 150°C maximum junction temperature operation, user-selectable PFM mode for lower current consumption at light-load conditions, configurable soft-start functions, open-drain FAULT and PG flags for fault reporting and output monitoring, independent enable inputs, monotonic start-up into prebiased loads, integrated VCC bias supply regulator powered from VIN or VOUT1, hiccup-mode overload protection, and thermal shutdown protection with automatic recovery. Current is sensed using the inductor DCR for highest efficiency or an optional shunt resistor for high accuracy.

The LM5137F-Q1 controller is qualified to AEC-Q100 grade 1 for automotive applications and comes in a 6mm × 6mm thermally-enhanced, 36-pin VQFN package with additional pin clearance for increased reliability. Also included are wettable flank pins to facilitate optical inspection during manufacturing. The wide input voltage range, low quiescent current consumption, high-temperature operation, cycle-by-cycle current limit, low EMI signature, and [small design size](#) provide an excellent point-of-load regulator design for functional safety (FuSa) applications requiring enhanced robustness and durability.

Table of Contents

1 Features	1	5.3 Receiving Notification of Documentation Updates	6
2 Applications	1	5.4 Support Resources	6
3 Description	1	5.5 Trademarks	6
4 Related Products	3	5.6 Electrostatic Discharge Caution	6
5 Device and Documentation Support	4	5.7 Glossary	6
5.1 Device Support.....	4	6 Revision History	7
5.2 Documentation Support.....	5	7 Mechanical, Packaging, and Orderable Information ...	7

4 Related Products

Table 4-1. Orderable Part Numbers

GENERIC PART NUMBER	ORDERABLE PART NUMBER	TI FUNCTIONAL SAFETY CLASSIFICATION ⁽¹⁾	PRODUCT DATA SHEET
LM5137-Q1	LM5137QRHARQ1	Functional safety-capable	Available here
LM5137F-Q1	LM5137FBQRHARQ1	ASIL B functional safety-compliant	Request the full data sheet here
	LM5137FDQRHARQ1	ASIL D functional safety-compliant	

(1) Refer to the [functional safety homepage](#) to understand the TI functional safety classifications (in terms of the development process, analysis report, and diagnostics description).

5 Device and Documentation Support

5.1 Device Support

5.1.1 Third-Party Products Disclaimer

TI'S PUBLICATION OF INFORMATION REGARDING THIRD-PARTY PRODUCTS OR SERVICES DOES NOT CONSTITUTE AN ENDORSEMENT REGARDING THE SUITABILITY OF SUCH PRODUCTS OR SERVICES OR A WARRANTY, REPRESENTATION OR ENDORSEMENT OF SUCH PRODUCTS OR SERVICES, EITHER ALONE OR IN COMBINATION WITH ANY TI PRODUCT OR SERVICE.

5.1.2 Development Support

With an input operating voltage as low as 3.5V and up to 100V as specified in [Table 5-1](#), the LM(2)514x-Q1 family of automotive synchronous buck controllers from TI provides flexibility, scalability and optimized design size for a variety of applications.

With the LM5137F-Q1 and LM25137F-Q1 available to aid in functional safety system design up to ASIL D, the controller family enables DC/DC designs with high density, low EMI, and increased system reliability. All controllers are rated for a maximum operating junction temperature of 150°C and have AEC-Q100 grade 1 qualification.

Table 5-1. Automotive Synchronous Buck DC/DC Controller Family

DC/DC CONTROLLER	SINGLE or DUAL	V _{IN} RANGE	CONTROL METHOD	GATE DRIVE VOLTAGE	SYNC OUTPUT	KEY FEATURE
LM5137-Q1	Dual	4V to 80V	Peak current mode	5V	90° phase shift	100% duty cycle
LM5137F-Q1	Dual	4V to 80V	Peak current mode	5V	90° phase shift	ASIL B or D
LM25137-Q1	Dual	4V to 42V	Peak current mode	5V	90° phase shift	100% duty cycle
LM25137F-Q1	Dual	4V to 42V	Peak current mode	5V	90° phase shift	ASIL B or D
LM5141-Q1	Single	3.8V to 65V	Peak current mode	5V	N/A	Split gate drive
LM25141-Q1	Single	3.8V to 42V	Peak current mode	5V	N/A	Split gate drive
LM5143A-Q1	Dual	3.5V to 65V	Peak current mode	5V	90° phase shift	Split gate drive
LM25143-Q1	Dual	3.5V to 42V	Peak current mode	5V	90° phase shift	Split gate drive
LM5145-Q1	Single	5.5V to 75V	Voltage mode	7.5V	180° phase shift	No shunt
LM5146-Q1	Single	5.5V to 100V	Voltage mode	7.5V	180° phase shift	100V input capability
LM5148-Q1	Single	3.5V to 80V	Peak current mode	5V	180° phase shift	DRSS
LM25148-Q1	Single	3.5V to 42V	Peak current mode	5V	180° phase shift	DRSS
LM5149-Q1	Single	3.5V to 80V	Peak current mode	5V	180° phase shift	AEF
LM25149-Q1	Single	3.5V to 42V	Peak current mode	5V	180° phase shift	AEF
LM5190-Q1	Single	5V to 80V	Peak current mode	7.5V	N/A	CC/CV
LM25190-Q1	Single	5V to 42V	Peak current mode	7.5V	N/A	CC/CV

For development support, see the following:

- [LM5137F-Q1 DC/DC controller Quickstart Calculator](#) and [PSPICE](#) simulation models
- [LM5137F-Q1-EVM12V](#) and [LM25137F-Q1-EVM5D3 Altium layout source](#) files
- For TI's WEBENCH design environments, visit the [WEBENCH® Design Center](#)
- For TI's reference design library, visit [TI Designs](#)
- TI Designs:
 - [Automotive Wide V_{IN} Front-end Reference Design for Digital Cockpit Processing Units](#)

5.1.2.1 Custom Design With WEBENCH® Tools

[Click here](#) to create a custom design using the LM5137F-Q1 device with the WEBENCH® Power Designer.

1. Start by entering the input voltage (V_{IN}), output voltage (V_{OUT}), and output current (I_{OUT}) requirements.
2. Optimize the design for key parameters such as efficiency, footprint, and cost using the optimizer dial.

3. Compare the generated design with other possible solutions from Texas Instruments.

The WEBENCH Power Designer gives a customized schematic along with a list of materials with real-time pricing and component availability.

In most cases, these actions are available:

- Run electrical simulations to see important waveforms and circuit performance
- Run thermal simulations to understand board thermal performance
- Export customized schematic and layout into popular CAD formats
- Print PDF reports for the design, and share the design with colleagues

Get more information about WEBENCH tools at www.ti.com/WEBENCH.

5.2 Documentation Support

5.2.1 Related Documentation

For related documentation, see the following:

- User's guides:
 - Texas Instruments, [LM5137F-Q1 Synchronous Buck Controller EVM](#)
 - Texas Instruments, [LM25137F-Q1 Synchronous Buck Controller EVM](#)
 - Texas Instruments, [LM5143-Q1 Synchronous Buck Controller EVM](#)
 - Texas Instruments, [LM5141-Q1 Synchronous Buck Controller EVM](#)
 - Texas Instruments, [LM5146-Q1 EVM User's Guide](#)
 - Texas Instruments, [LM5145EVM-HD-20A High Density Evaluation Module](#)
 - Texas Instruments, [LM5149-Q1 Buck Controller Evaluation Module](#)
 - Texas Instruments, [LM5190-Q1 CC-CV Buck Controller Evaluation Module](#)
- Application reports:
 - Texas Instruments, [LM5143-Q1 4-phase Buck Regulator Design for Automotive ADAS Applications](#)
 - Texas Instruments, [Maintaining Output Voltage Regulation During Automotive Cold-Crank with LM5140-Q1 Dual Synchronous Buck Controller](#)
- Technical articles:
 - Texas Instruments, [Achieving functional safety compliance in automotive off-battery buck preregulator designs](#)
 - Texas Instruments, [Powering next-generation ADAS processors with TI Functional Safety-Compliant buck regulators](#)

5.2.1.1 Low-EMI Design Resources

- Texas Instruments, [Low EMI](#) landing page
- Texas Instruments, [Tackling the EMI challenge](#) company blog
- Texas Instruments, [An Engineer's Guide to Low EMI in DC/DC Regulators](#) e-book
- Texas Instruments, [Designing a low-EMI power supply](#) video series
- White papers:
 - Texas Instruments, [An Overview of Conducted EMI Specifications for Power Supplies](#)
 - Texas Instruments, [An Overview of Radiated EMI Specifications for Power Supplies](#)
 - Texas Instruments, [Time-Saving and Cost-Effective Innovations for EMI Reduction in Power Supplies](#)
 - Texas Instruments, [Valuing Wide \$V_{IN}\$, Low EMI Synchronous Buck Circuits for Cost-driven, Demanding Applications](#)
- Applications notes:
 - Texas Instruments, [Improve High-Current DC/DC Regulator EMI for Free With Optimized Power Stage Layout](#)
 - Texas Instruments, [Reduce Buck Converter EMI and Voltage Stress by Minimizing Inductive Parasitics](#)

5.2.1.2 Thermal Design Resources

- White paper:
 - Texas Instruments, [Improving Thermal Performance in High Ambient Temperature Environments With Thermally Enhanced Packaging](#)
- Applications notes:
 - Texas Instruments, [Thermal Design by Insight, Not Hindsight](#)
 - Texas Instruments, [A Guide to Board Layout for Best Thermal Resistance for Exposed Pad Packages](#)
 - Texas Instruments, [Semiconductor and IC Package Thermal Metrics](#)
 - Texas Instruments, [PowerPAD™ Thermally Enhanced Package](#)
 - Texas Instruments, [PowerPAD™ Made Easy](#)
 - Texas Instruments, [Using New Thermal Metrics](#)

5.2.1.3 PCB Layout Resources

- LM5137F-Q1-EVM12V and LM25137F-Q1-EVM5D3 [Altium layout](#) source files
- Applications notes:
 - Texas Instruments, [Improve High-Current DC/DC Regulator EMI Performance for Free With Optimized Power Stage Layout](#)
 - Texas Instruments, [AN-1149 Layout Guidelines for Switching Power Supplies](#)
- Seminar:
 - Texas Instruments, [Constructing Your Power Supply – Layout Considerations](#)

5.3 Receiving Notification of Documentation Updates

To receive notification of documentation updates, navigate to the device product folder on ti.com. Click on *Notifications* to register and receive a weekly digest of any product information that has changed. For change details, review the revision history included in any revised document.

5.4 Support Resources

[TI E2E™ support forums](#) are an engineer's go-to source for fast, verified answers and design help — straight from the experts. Search existing answers or ask your own question to get the quick design help you need.

Linked content is provided "AS IS" by the respective contributors. They do not constitute TI specifications and do not necessarily reflect TI's views; see TI's [Terms of Use](#).

5.5 Trademarks

PowerPAD™ and TI E2E™ are trademarks of Texas Instruments.
WEBENCH® is a registered trademark of Texas Instruments.
All trademarks are the property of their respective owners.

5.6 Electrostatic Discharge Caution



This integrated circuit can be damaged by ESD. Texas Instruments recommends that all integrated circuits be handled with appropriate precautions. Failure to observe proper handling and installation procedures can cause damage.

ESD damage can range from subtle performance degradation to complete device failure. Precision integrated circuits may be more susceptible to damage because very small parametric changes could cause the device not to meet its published specifications.

5.7 Glossary

[TI Glossary](#) This glossary lists and explains terms, acronyms, and definitions.

6 Revision History

NOTE: Page numbers for previous revisions may differ from page numbers in the current version.

Changes from Revision * (September 2024) to Revision A (June 2025)	Page
• Changed the document status from Advance Information to Production Data.....	1

7 Mechanical, Packaging, and Orderable Information

The following pages show mechanical, packaging, and orderable information. This information is the most current data available for the designated devices. This data is subject to change without notice and revision of this document. For browser-based versions of this data sheet, refer to the left-hand navigation.

PACKAGING INFORMATION

Orderable part number	Status (1)	Material type (2)	Package Pins	Package qty Carrier	RoHS (3)	Lead finish/ Ball material (4)	MSL rating/ Peak reflow (5)	Op temp (°C)	Part marking (6)
LM5137FBQRHARQ1	Active	Production	VQFN (RHA) 36	2500 LARGE T&R	Yes	NIPDAU	Level-2-260C-1 YEAR	-40 to 125	5137FBQ RHARQ1
LM5137FDQRHARQ1	Active	Production	VQFN (RHA) 36	2500 LARGE T&R	Yes	NIPDAU	Level-2-260C-1 YEAR	-40 to 125	5137FDQ RHARQ1

(1) **Status:** For more details on status, see our [product life cycle](#).

(2) **Material type:** When designated, preproduction parts are prototypes/experimental devices, and are not yet approved or released for full production. Testing and final process, including without limitation quality assurance, reliability performance testing, and/or process qualification, may not yet be complete, and this item is subject to further changes or possible discontinuation. If available for ordering, purchases will be subject to an additional waiver at checkout, and are intended for early internal evaluation purposes only. These items are sold without warranties of any kind.

(3) **RoHS values:** Yes, No, RoHS Exempt. See the [TI RoHS Statement](#) for additional information and value definition.

(4) **Lead finish/Ball material:** Parts may have multiple material finish options. Finish options are separated by a vertical ruled line. Lead finish/Ball material values may wrap to two lines if the finish value exceeds the maximum column width.

(5) **MSL rating/Peak reflow:** The moisture sensitivity level ratings and peak solder (reflow) temperatures. In the event that a part has multiple moisture sensitivity ratings, only the lowest level per JEDEC standards is shown. Refer to the shipping label for the actual reflow temperature that will be used to mount the part to the printed circuit board.

(6) **Part marking:** There may be an additional marking, which relates to the logo, the lot trace code information, or the environmental category of the part.

Multiple part markings will be inside parentheses. Only one part marking contained in parentheses and separated by a "-" will appear on a part. If a line is indented then it is a continuation of the previous line and the two combined represent the entire part marking for that device.

Important Information and Disclaimer:The information provided on this page represents TI's knowledge and belief as of the date that it is provided. TI bases its knowledge and belief on information provided by third parties, and makes no representation or warranty as to the accuracy of such information. Efforts are underway to better integrate information from third parties. TI has taken and continues to take reasonable steps to provide representative and accurate information but may not have conducted destructive testing or chemical analysis on incoming materials and chemicals. TI and TI suppliers consider certain information to be proprietary, and thus CAS numbers and other limited information may not be available for release.

In no event shall TI's liability arising out of such information exceed the total purchase price of the TI part(s) at issue in this document sold by TI to Customer on an annual basis.

OTHER QUALIFIED VERSIONS OF LM5137F-Q1 :

- Catalog : [LM5137F](#)

NOTE: Qualified Version Definitions:

- Catalog - TI's standard catalog product

TAPE AND REEL INFORMATION

QUADRANT ASSIGNMENTS FOR PIN 1 ORIENTATION IN TAPE

*All dimensions are nominal

Device	Package Type	Package Drawing	Pins	SPQ	Reel Diameter (mm)	Reel Width W1 (mm)	A0 (mm)	B0 (mm)	K0 (mm)	P1 (mm)	W (mm)	Pin1 Quadrant
LM5137FBQRHARQ1	VQFN	RHA	36	2500	330.0	16.4	6.3	6.3	1.1	12.0	16.0	Q2
LM5137FDQRHARQ1	VQFN	RHA	36	2500	330.0	16.4	6.3	6.3	1.1	12.0	16.0	Q2

TAPE AND REEL BOX DIMENSIONS

*All dimensions are nominal

Device	Package Type	Package Drawing	Pins	SPQ	Length (mm)	Width (mm)	Height (mm)
LM5137FBQRHARQ1	VQFN	RHA	36	2500	367.0	367.0	38.0
LM5137FDQRHARQ1	VQFN	RHA	36	2500	367.0	367.0	38.0

GENERIC PACKAGE VIEW

RHA 36

VQFN - 1 mm max height

6 x 6, 0.5 mm pitch

PLASTIC QUAD FLATPACK - NO LEAD

This image is a representation of the package family, actual package may vary.
Refer to the product data sheet for package details.

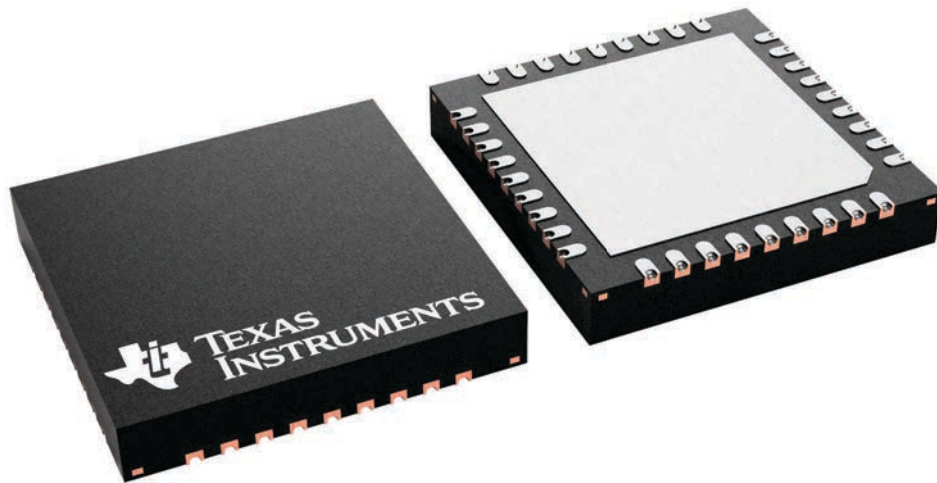

4228438/A

RHA0036D

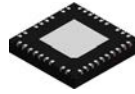

PACKAGE OUTLINE

VQFN - 1 mm max height

PLASTIC QUAD FLATPACK - NO LEAD

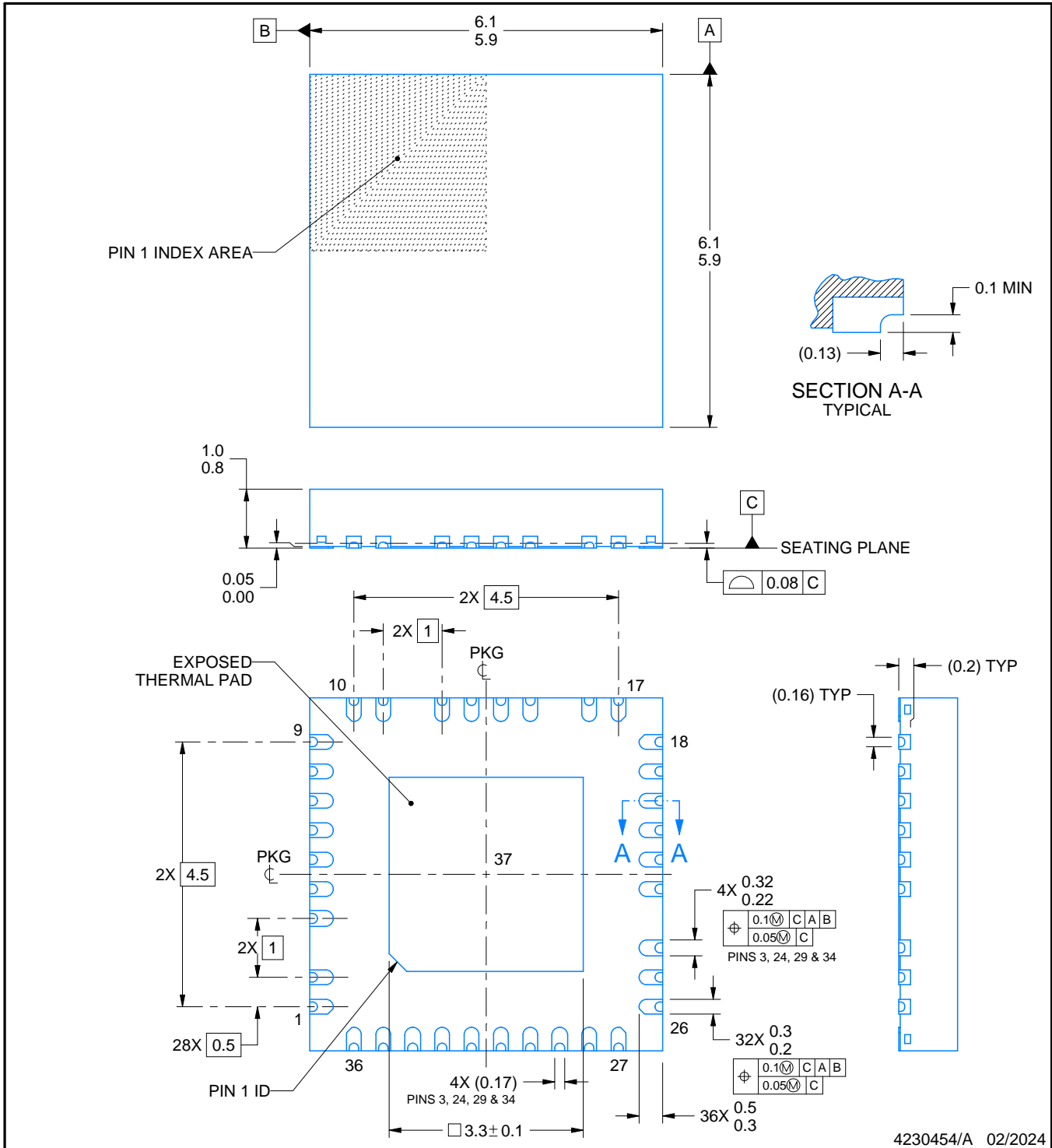

NOTES:

1. All linear dimensions are in millimeters. Any dimensions in parenthesis are for reference only. Dimensioning and tolerancing per ASME Y14.5M.
2. This drawing is subject to change without notice.
3. The package thermal pad must be soldered to the printed circuit board for thermal and mechanical performance.

EXAMPLE BOARD LAYOUT

RHA0036D

VQFN - 1 mm max height

PLASTIC QUAD FLATPACK - NO LEAD

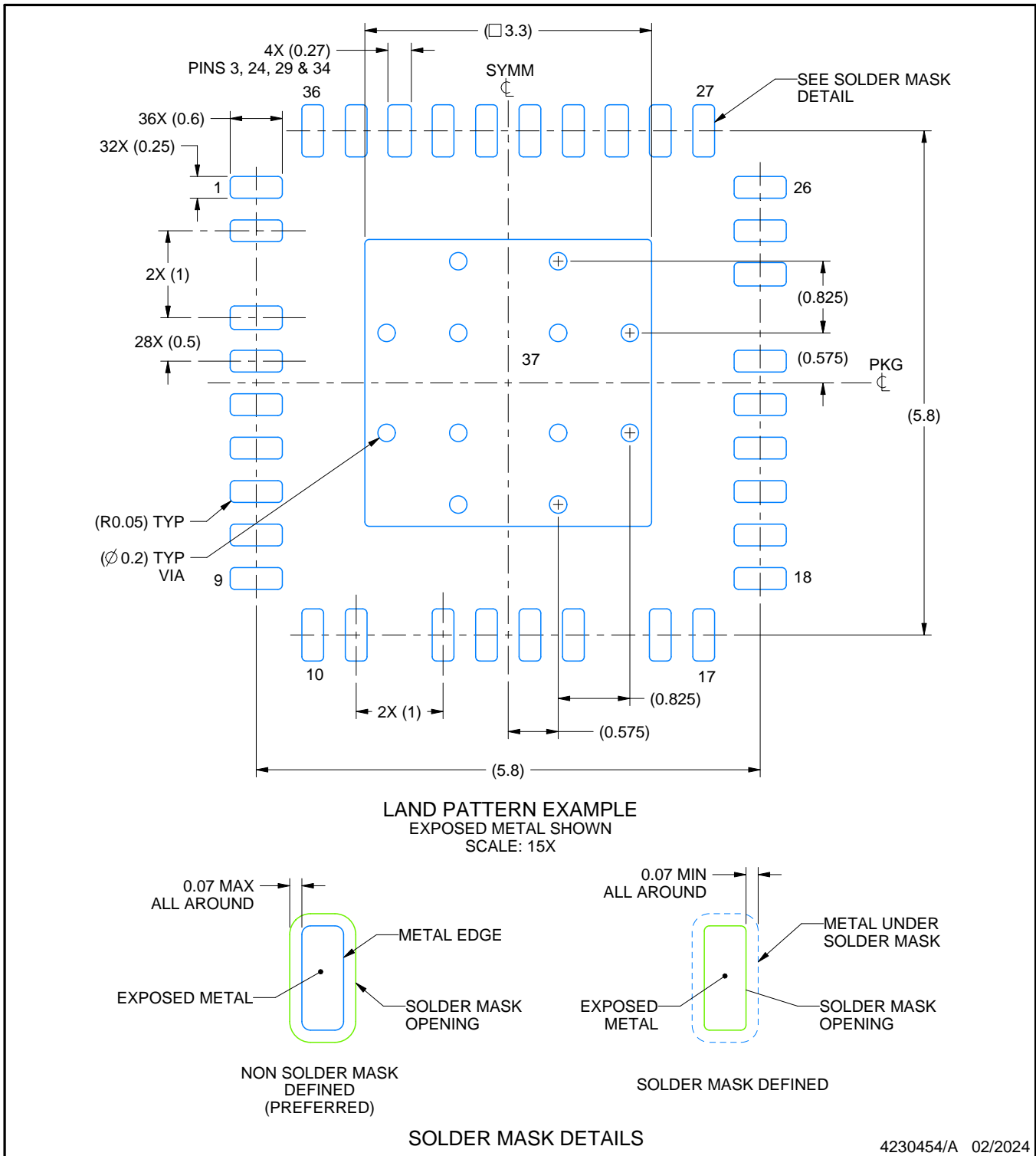

NOTES: (continued)

- This package is designed to be soldered to a thermal pad on the board. For more information, see Texas Instruments literature number SLUA271 (www.ti.com/lit/slua271).
- Vias are optional depending on application, refer to device data sheet. If any vias are implemented, refer to their locations shown on this view. It is recommended that vias under paste be filled, plugged or tented.

EXAMPLE STENCIL DESIGN

RHA0036D

VQFN - 1 mm max height

PLASTIC QUAD FLATPACK - NO LEAD

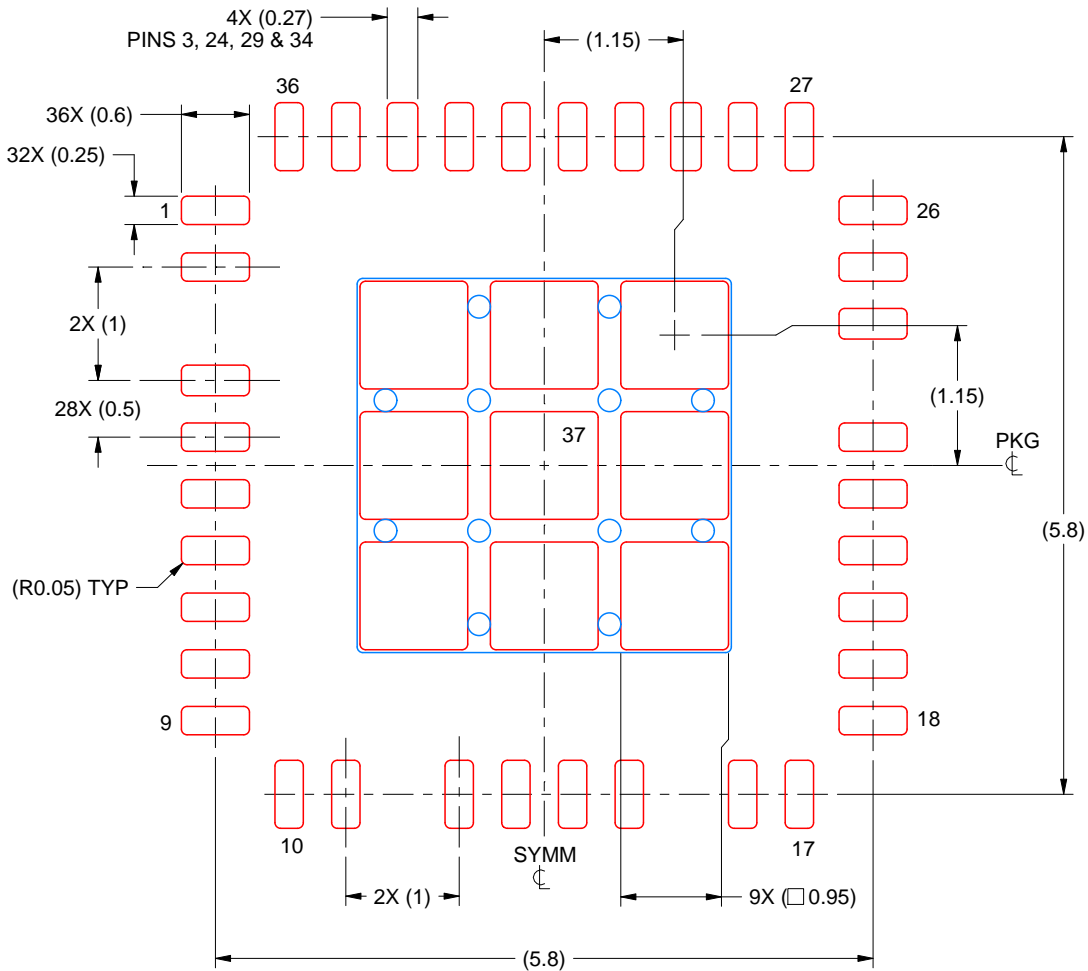

SOLDER PASTE EXAMPLE
BASED ON 0.125 MM THICK STENCIL
SCALE: 15X

EXPOSED PAD 37
75% PRINTED SOLDER COVERAGE BY AREA UNDER PACKAGE

4230454/A 02/2024

NOTES: (continued)

6. Laser cutting apertures with trapezoidal walls and rounded corners may offer better paste release. IPC-7525 may have alternate design recommendations.

IMPORTANT NOTICE AND DISCLAIMER

TI PROVIDES TECHNICAL AND RELIABILITY DATA (INCLUDING DATASHEETS), DESIGN RESOURCES (INCLUDING REFERENCE DESIGNS), APPLICATION OR OTHER DESIGN ADVICE, WEB TOOLS, SAFETY INFORMATION, AND OTHER RESOURCES "AS IS" AND WITH ALL FAULTS, AND DISCLAIMS ALL WARRANTIES, EXPRESS AND IMPLIED, INCLUDING WITHOUT LIMITATION ANY IMPLIED WARRANTIES OF MERCHANTABILITY, FITNESS FOR A PARTICULAR PURPOSE OR NON-INFRINGEMENT OF THIRD PARTY INTELLECTUAL PROPERTY RIGHTS.

These resources are intended for skilled developers designing with TI products. You are solely responsible for (1) selecting the appropriate TI products for your application, (2) designing, validating and testing your application, and (3) ensuring your application meets applicable standards, and any other safety, security, regulatory or other requirements.

These resources are subject to change without notice. TI grants you permission to use these resources only for development of an application that uses the TI products described in the resource. Other reproduction and display of these resources is prohibited. No license is granted to any other TI intellectual property right or to any third party intellectual property right. TI disclaims responsibility for, and you fully indemnify TI and its representatives against any claims, damages, costs, losses, and liabilities arising out of your use of these resources.

TI's products are provided subject to [TI's Terms of Sale](#), [TI's General Quality Guidelines](#), or other applicable terms available either on ti.com or provided in conjunction with such TI products. TI's provision of these resources does not expand or otherwise alter TI's applicable warranties or warranty disclaimers for TI products. Unless TI explicitly designates a product as custom or customer-specified, TI products are standard, catalog, general purpose devices.

TI objects to and rejects any additional or different terms you may propose.

Copyright © 2026, Texas Instruments Incorporated

Last updated 10/2025