

LMG1020-Q1 5V, 7A, 5A Low-Side GaN and MOSFET Driver For 1ns Pulse Width Automotive Applications

1 Features

- Qualified for automotive applications
- AEC-Q100 qualified
 - Device temperature grade 1
- Low-side, ultra-fast gate driver for GaN and silicon FETs
- 1ns minimum input pulse width
- Up to 60MHz operation
- 2.5ns typical, 4.5ns maximum propagation delay
- 400ps typical rise and fall time
- 7A peak source and 5A peak sink currents
- 5V supply voltage
- UVLO and overtemperature protection
- 0.8mm × 1.2mm WCSP package

2 Applications

- LiDAR
- Time-of-flight laser drivers
- Facial recognition
- Class-E wireless chargers
- VHF resonant power converters
- GaN-based synchronous rectifier
- Augmented reality

3 Description

The LMG1020-Q1 device is a single, low-side driver designed for driving GaN FETs and logic-level MOSFETs in high-speed applications including LiDAR, time-of-flight, facial recognition, and any power converters involving low-side. The design simplicity of the LMG1020-Q1 enables extremely fast propagation delays of 2.5 ns and minimum pulse width of 1ns. The drive strength is independently adjustable for the pull-up and pull-down edges by connecting external resistors between the gate and OUTH and OUTL, respectively.

The driver features undervoltage lockout (UVLO) and overtemperature protection (OTP) in the event of overload or fault conditions.

The 0.8mm × 1.2mm WCSP package of the LMG1020-Q1 minimizes gate loop inductance and maximizes power density in high-frequency applications.

Device Information

PART NUMBER	PACKAGE ⁽¹⁾	BODY SIZE (NOM)
LMG1020-Q1	YBV (WCSP 6)	0.80mm × 1.20mm

(1) For all available packages, see [Section 10](#).

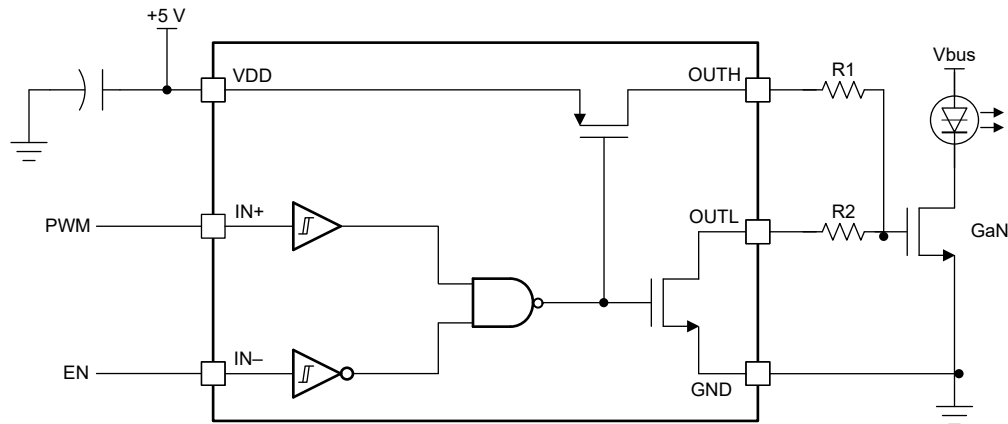

Simplified LiDAR Driver Stage Diagram



Table of Contents

1 Features	1	7 Application and Implementation	9
2 Applications	1	7.1 Application Information.....	9
3 Description	1	7.2 Typical Application.....	9
4 Pin Configuration and Functions	3	7.3 Power Supply Recommendations.....	13
5 Specifications	4	7.4 Layout.....	14
5.1 Absolute Maximum Ratings.....	4	8 Device and Documentation Support	16
5.2 ESD Ratings.....	4	8.1 Third-Party Products Disclaimer.....	16
5.3 Recommended Operating Conditions.....	4	8.2 Documentation Support.....	16
5.4 Thermal Information.....	4	8.3 Receiving Notification of Documentation Updates....	16
5.5 Electrical Characteristics.....	5	8.4 Support Resources.....	16
5.6 Switching Characteristics.....	5	8.5 Trademarks.....	16
5.7 Typical Characteristics.....	6	8.6 Electrostatic Discharge Caution.....	16
6 Detailed Description	7	8.7 Glossary.....	16
6.1 Overview.....	7	9 Revision History	16
6.2 Functional Block Diagram.....	7	10 Mechanical, Packaging, and Orderable Information	17
6.3 Feature Description.....	7		
6.4 Device Functional Modes.....	8		

4 Pin Configuration and Functions

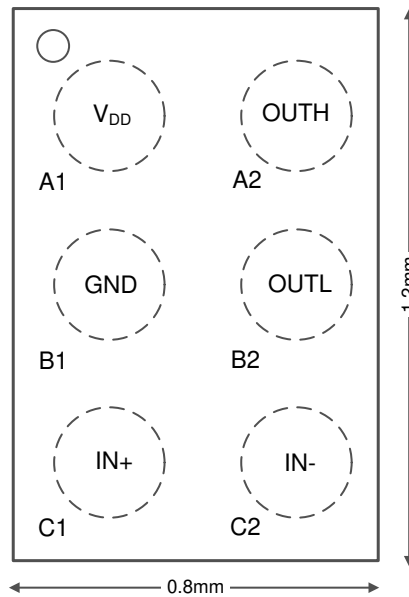

Figure 4-1. YBV Package 6-Ball WCSP Top View

Table 4-1. Pin Functions

PIN		I/O	DESCRIPTION
NAME	NO.		
GND	B1	—	Ground
IN+	C1	I	Positive logic-level input
IN-	C2	I	Negative logic-level input
OUTL	B2	O	Pulldown gate drive output. Connect through an optional resistor to the target transistor's gate
OUTH	A2	O	Pullup gate drive output. Connect through a resistor to the target transistor's gate
VDD	A1	I	Input voltage supply. Decouple through a small size, low inductance capacitor to GND

5 Specifications

5.1 Absolute Maximum Ratings

over operating free-air temperature range (unless otherwise noted)⁽¹⁾

		MIN	MAX	UNIT
V _{DD}	Supply voltage		5.75	V
V _{IN}	IN+, IN- pin voltage	-0.3	V _{DD} + 0.3	V
V _{OUT}	OUTH, OUTL pin voltage	-0.3	5.75	V
T _{STG}	Storage Temperature	-55	150	°C
T _J	Operating Temperature	-40	150	°C

- (1) Stresses beyond those listed under *Absolute Maximum Rating* may cause permanent damage to the device. These are stress ratings only, which do not imply functional operation of the device at these or any other conditions beyond those indicated under *Recommended Operating Condition*. Exposure to absolute-maximum-rated conditions for extended periods may affect device reliability.

5.2 ESD Ratings

			VALUE	UNIT
V _(ESD)	Electrostatic discharge	Human body model (HBM), per AEC Q100-002, all pins ⁽¹⁾	±2000	V
		Charged device model (CDM), per AEC Q100-011, all pins	±500	

- (1) AEC Q100-002 indicates that HBM stressing shall be in accordance with the ANSI/ESDA/JEDEC JS-001 specification.

5.3 Recommended Operating Conditions

over operating free-air temperature range (unless otherwise noted)

		MIN	NOM	MAX	UNIT
V _{DD}	Supply voltage	4.75	5	5.4	V
V _{INx}	IN+ or IN- input voltage	0		V _{DD}	V
T _J	Operating Temperature	-40		125	°C

5.4 Thermal Information

THERMAL METRIC ⁽¹⁾		LMG1020-Q1	UNIT
		YBV (WCSP)	
		6 PINS	
R _{θJA}	Junction-to-ambient thermal resistance	131.9	°C/W
R _{θJC(top)}	Junction-to-case (top) thermal resistance	52.4	°C/W
R _{θJB}	Junction-to-board thermal resistance	37.6	°C/W
Ψ _{JT}	Junction-to-top characterization parameter	0.3	°C/W
Y _{JB}	Junction-to-board characterization parameter	37.6	°C/W
R _{θJC(bot)}	Junction-to-case (bottom) thermal resistance	N/A	°C/W

- (1) For more information about traditional and new thermal metrics, see the [Semiconductor and IC Package Thermal Metrics](#) application report.

5.5 Electrical Characteristics

over operating free-air temperature range (VDD=5V unless otherwise noted)

PARAMETER		TEST CONDITIONS	MIN	TYP	MAX	UNIT
DC Characteristics						
$I_{VDD, Q}$	VDD Quiescent Current	$IN_+ = IN_- = 0\text{ V}$			75	μA
$I_{VDD, op}$	VDD Operating Current	fsw = 30 MHz, 2 Ω , 0.1 pF load		40		mA
		fsw = 30MHz, 2 Ω , 100pF load		51		mA
$V_{DD, UVLO}$	Under-voltage Lockout	V_{DD} rising	4.06	4.19	4.33	V
$\Delta V_{DD, UVLO}$	UVLO Hysteresis			85		mV
T_{OTP}	Over temperature shutdown, rising edge threshold			170		$^{\circ}\text{C}$
ΔT_{OTP}	Over temperature hysteresis			18		$^{\circ}\text{C}$
Input DC Characteristics						
V_{IH}	IN_+ , IN_- high threshold		1.7		2.6	V
V_{IL}	IN_+ , IN_- low threshold		1.1		1.8	V
V_{HYST}	IN_+ , IN_- hysteresis		0.5		1	V
R_{IN+}	Positive input pull-down resistance	To GND	100	150	250	$\text{k}\Omega$
R_{IN-}	Negative input pull-up resistance	to V_{DD}	100	150	250	$\text{k}\Omega$
$C_{IN}^{(1)}$	Input pin capacitance	To GND		1.3		pF
Output DC Characteristics						
V_{OL}	OUTL voltage	$I_{OUTL} = 100\text{ mA}$, $IN_+ = IN_- = 0\text{ V}$			36	mV
$V_{DD} - V_{OH}$	OUTH voltage	$I_{OUTH} = 100\text{ mA}$, $IN_+ = 5\text{ V}$, $IN_- = 0\text{ V}$, $V_{DD} = 5\text{ V}$			50	mV
$I_{OH}^{(1)}$	Peak source current	$V_{OUTH} = 0\text{ V}$, $IN_+ = 5\text{ V}$, $IN_- = 0\text{ V}$, $V_{DD} = 5\text{ V}$		7		A
$I_{OL}^{(1)}$	Peak sink current	$V_{OUTL} = 5\text{ V}$, $IN_+ = IN_- = 0\text{ V}$, $V_{DD} = 5\text{ V}$		5		A

(1) Ensured by design

5.6 Switching Characteristics

over operating free-air temperature range (VDD=5V unless otherwise noted)

PARAMETER		TEST CONDITIONS	MIN	TYP	MAX	UNIT
t_{start}	Startup Time, V_{DD} rising above UVLO	$IN_- = \text{GND}$, $IN_+ = V_{DD}$, V_{DD} rising to 4.2V to OUTH rising		40	70	μs
$t_{shut-off}$	ULVO falling	$IN_- = \text{GND}$, $IN_+ = V_{DD}$, V_{DD} falling below 4.1V to OUTH falling	1	1.9	3.1	μs
$t_{pd, r}$	Propagation delay, turn on	$IN_- = 0\text{ V}$, IN_+ to OUTH, 100 pF load	1.5	2.5	4.1	ns
$t_{pd, f}$	Propagation delay, turn off	$IN_- = 0\text{ V}$, IN_+ to OUTL, 100 pF load	1.8	2.6	4.3	ns
Δt_{pd}	Pulse positive distortion ($t_{pd, r} - t_{pd, f}$)			230	603	ps
t_{rise}	Output rise time	0 Ω series 100 pF load ⁽¹⁾		375		ps
t_{fall}	Output fall time	0 Ω series 100 pF load ⁽¹⁾		350		ps
t_{min}	Minimum pulse width	0 Ω series 100 pF load ⁽¹⁾		1		ns

(1) Rise and fall calculated as 20% to 80%

5.7 Typical Characteristics

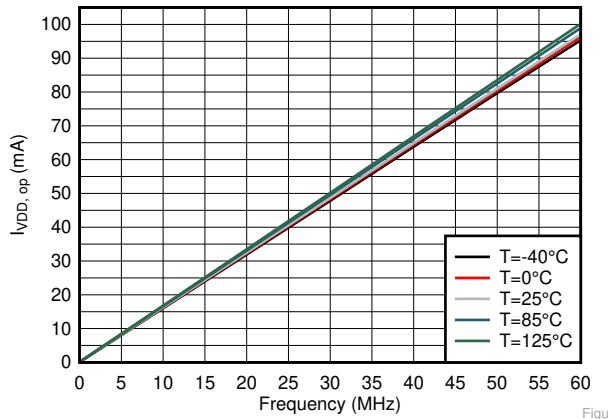

Figure 5-1. $I_{VDD,op}$ vs Frequency With 2Ω Series 100pF Load

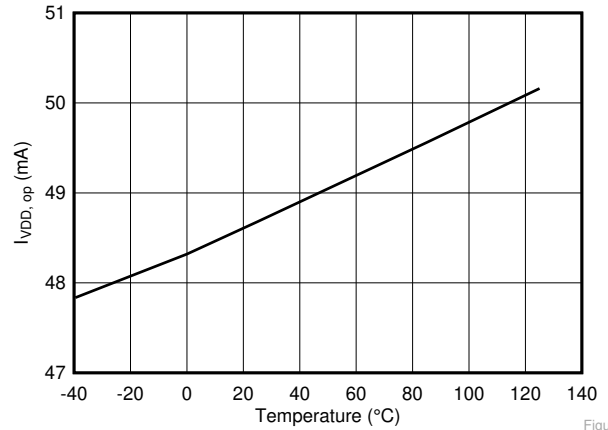

Figure 5-2. $I_{VDD,op}$ vs Temperature At 30MHz With 2Ω Series 100pF Load

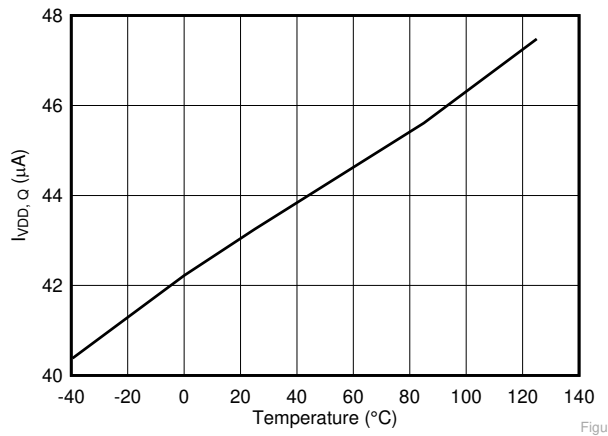

Figure 5-3. Quiescent Current vs Temperature

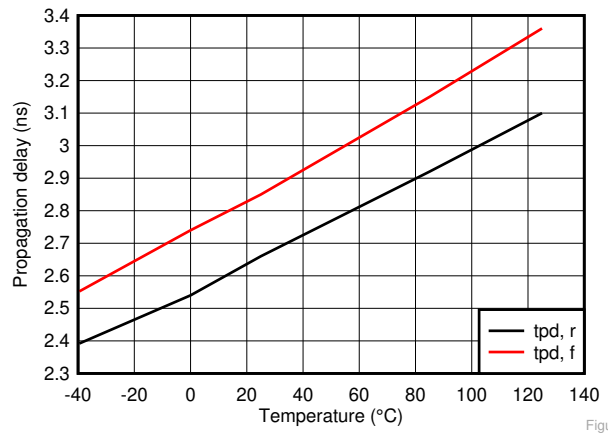

Figure 5-4. Propagation Delay vs Temperature

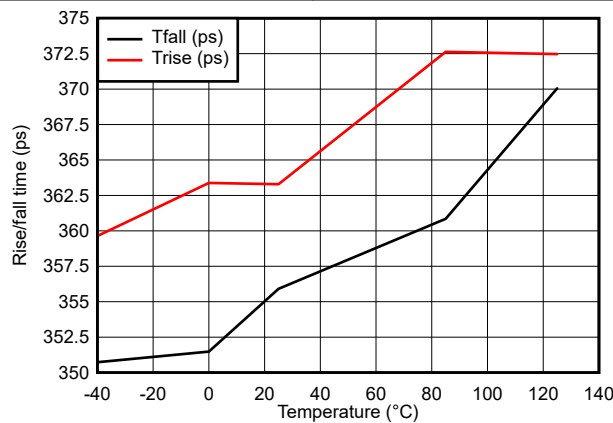

Figure 5-5. Rise And Fall Time vs Temperature With 0Ω Series 100pF Load

6 Detailed Description

6.1 Overview

LMG1020-Q1 is a high-performance low-side 5V gate driver for GaN and logic-level silicon power transistors. While the LMG1020-Q1 is designed for high-speed applications, such as wireless power transmission and LiDAR applications, it is a high-performance solution for any other low-side driving applications.

The LMG1020-Q1 is optimized to provide the lowest propagation delay through the driver to the power transistor. LMG1020-Q1 is in a small 0.8×1.2mm WCSP ball-grid array package in order to minimize its parasitic inductance. This low inductance design helps achieve high current, low ringing performance in very high frequency operation when driving power FETs.

6.2 Functional Block Diagram

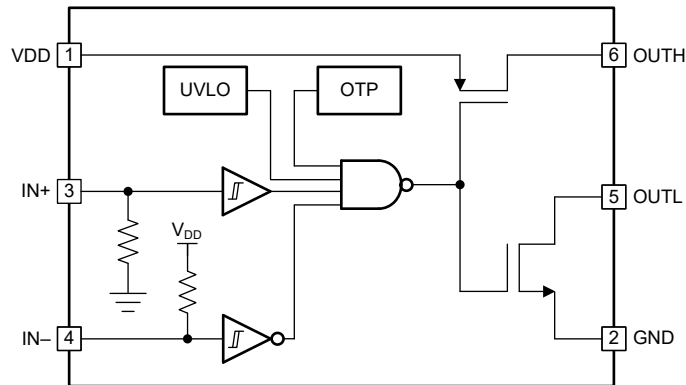

6.3 Feature Description

6.3.1 Input Stage

The input stage features two Schmitt-triggers at the pins IN+ and IN- to reduce sensitivity to noise on the inputs. IN+ signal and the inverted IN- signal are both sent to an NAND gate. IN+ is connected with a pull-down resistor while IN- is connected with a pull-up resistor to prevent unintended turnon. The output signal will follow the difference between IN+ and IN-. Both IN+ and IN- are single ended inputs, and these two pins cannot be used as a differential input pair.

6.3.2 Output Stage

LMG1020-Q1 provides 7A source, 5A sink (asymmetrical drive) peak-drive current capability, and features a split output configuration. The OUTH and OUTL outputs of the LMG1020-Q1 allow the user to use independent resistors connecting to the gate. The two resistors allow the user to independently adjust the turnon and turnoff drive strengths to control slew rate and EMI, and to control ringing on the gate signal. For GaN FETs, controlling ringing is important to reduce stress on the GaN FET and driver. The output stage OUTL is also pulled down in undervoltage condition, which prevents the unintended charge accumulation of device C_{iss} .

6.3.3 V_{DD} and Undervoltage Lockout

LMG1020-Q1 features nominal 5V and maximum 5.25V of supply voltage, and its absolute maximum supply voltage is 5.75V. In the design, it is recommended to limit the variability of the power supply to be within 5% (0.25V), and the overshoot voltage during switching transient not to exceed the absolute maximum voltage. Refer to [Section 7.2.3](#) for more the detailed design guide.

LMG1020-Q1 also features internal undervoltage lockout (UVLO) to protect the driver and circuit in case of fault conditions. The UVLO point is setup between 4.1V and 4.2V with a hysteresis of 85mV. This UVLO level is specifically designed to guarantee that GaN power devices can be switched at a low $R_{DS(on)}$ region. During UVLO condition, the OUTL is pulled down to ground.

6.3.4 Overtemperature Protection (OTP)

LMG1020-Q1 features overtemperature protection (OTP) function by having a rising edge trigger point at around 170°C. With a hysteresis of 20°C, the device can restart to operate when junction temperature is below 150°C.

6.4 Device Functional Modes

Table 6-1. Truth Table

IN-	IN+	OUTH	OUTL
L	L	OPEN	L
L	H	H	OPEN
H	L	OPEN	L
H	H	OPEN	L

7 Application and Implementation

Note

Information in the following applications sections is not part of the TI component specification, and TI does not warrant its accuracy or completeness. TI's customers are responsible for determining suitability of components for their purposes, as well as validating and testing their design implementation to confirm system functionality.

7.1 Application Information

To operate GaN transistors at very high switching frequencies and to reduce associated switching losses, a powerful gate driver is employed between the PWM output of controller and the gates of the GaN transistor. Also, gate drivers are indispensable when the outputs of the PWM controller do not meet the voltage or current levels needed to directly drive the gates of the switching devices. With the advent of digital power, this situation is often encountered because the PWM signal from the digital controller is often a 3.3V logic signal, which cannot effectively turn on a power switch. A level-shift circuit is needed to boost the 3.3V signal to the gate-drive voltage (such as 5V) in order to fully turn on the power device and minimize conduction losses.

Gate drivers effectively provide the buffer-drive functions. Gate drivers also address other needs such as minimizing the effect of high-frequency switching noise (by placing the high-current driver IC physically close to the power switch), reducing power dissipation and thermal stress in controllers by moving gate charge power losses from the controller into the driver.

The LMG1020-Q1 is a 60MHz low-side gate driver for enhancement mode GaN FETs and Si FETs in a single-ended configuration. The split-gate outputs with strong source and sink capability provides flexibility to adjust the turnon and turnoff strength independently. As a low side driver, LMG1020-Q1 can be used in a variety of applications, including different power converters, LiDAR, time-of-flight laser drivers, class-E wireless chargers, synchronous rectifiers, and augmented reality. The LMG1020-Q1 can also be used as a high frequency low current laser diode driver, or as a signal buffer with very fast rise/fall time.

7.2 Typical Application

The LMG1020-Q1 is designed to be used with a single low-side, ground-referenced GaN or logic-level Si FET, as shown in [Figure 7-1](#). Independent gate drive resistors, R1 and R2, are used to independently control the turnon and turnoff drive strengths, respectively. For fast and strong turnoff, R2 can be shorted and OUTL directly connected to the transistor's gate. For symmetric drive strengths, it is acceptable to short OUTH and OUTL and use a single gate-drive resistor.

TI recommends using at least a 2Ω resistor at each OUTH and OUTL to avoid voltage overstress due to inductive ringing. Ringing overshoot must not exceed the maximum absolute supply voltage.

For applications requiring smaller resistance values, contact TI E2E for guidance.

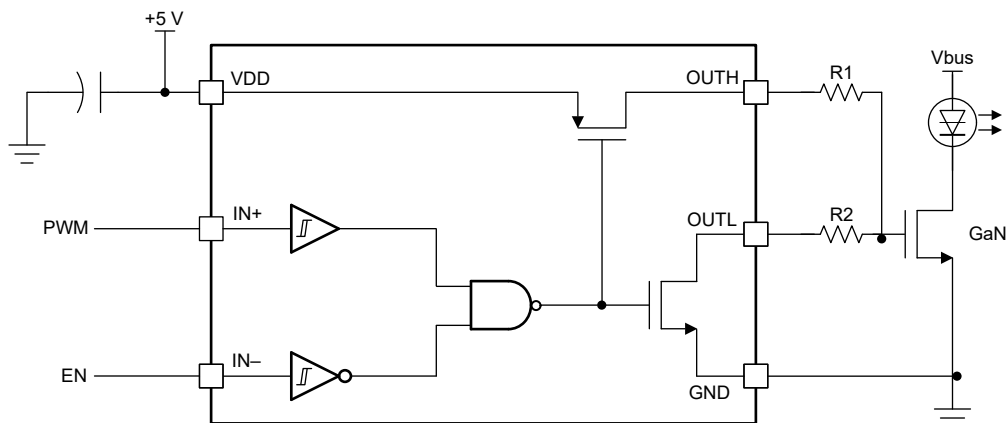

Figure 7-1. Typical Implementation of a Circuit

7.2.1 Design Requirements

When designing a multi-MHz (or nano-second pulse) application that incorporates the LMG1020-Q1 gate driver and GaN power FETs, some design considerations must be evaluated first to make the most appropriate selection. Among these considerations are layout optimization, circuit voltages, passive components, operating frequency, and controller selection.

7.2.2 Detailed Design Procedure

7.2.2.1 Handling Ground Bounce

For the best switching performance and gate loop with lowest parasitics, it is recommended to connect the ground return pin of LMG1020-Q1 as close as possible to the source of the low-side FET in a low inductance manner. However, doing so can cause the ground of LMG1020-Q1 to bounce relative to the system or controller ground and lead to erroneous switching logic on the input so as mis-turn on/off on the output.

First of all, LMG1020-Q1 has input hysteresis built into the input buffers to help counteract this effect. The maximum di/dt allowed to prevent the input voltage transient from exceeding the input hysteresis is given by [Equation 1](#)

$$\frac{di_s}{dt} = \frac{V_{HYST}}{L_{RS}} \quad (1)$$

where

- L_{RS} is the inductance between FET source and ground,
- V_{HYST} is the hysteresis of the input pin,
- and $di_s/\Delta t$ is the maximum allowed current slew rate.

For an assumed parasitic inductance of 0.5nH and a minimum hysteresis of 0.5V, the maximum slew rate is 1A/ns. Many applications would exhibit higher current slew rates, up to the 10A/ns range, which would make this approach impractical. The stability of this approach can be improved by using the IN– input for the PWM signal and locally tying IN+ to VDD. By using the inverting input, the transient voltage applied to the input pin reinforces the PWM signal in a positive feedback loop. While this approach would reduce the probability of false pulses or oscillation, the transient spikes due to high di/dt may overly stress the inputs to the LMG1020-Q1. A current-limiting, 100Ω resistor can be placed right before the IN– input to limit excessive current spikes in the device.

Secondly, for moderate ground-bounce cases, a simple R-C filter can be built with a simple resistor in series with the inputs. By utilizing the input capacitance of the LMG1020-Q1, the resistor could be close to its input pin. The addition of a small capacitor on the input as supplement can also be helpful. A small time constant of the R-C filter can be enough to filter out high frequency noises. This solution is acceptable for moderate cases in applications where extra delay is acceptable and the pulse width is not extremely short such as 1ns range.

For more extreme cases, or where no delay is tolerable while pulse width is extremely short, using a common-mode choke provides the best results.

One example application where ground-bounce is particularly challenging is when using a current sense resistor. In configuration A LMG1020-Q1 ground is connected to the source of GaN FET, while the controller ground is connected to the other side of the current sense resistor as shown in [Figure 7-2](#). Due to the fast switching and very fast current slew rates, the high ground potential bounce induced by inductance of the sense resistor can disrupt the operation of the circuit or even damage the part. To prevent this, a common-mode choke can be used for IN+ and IN–, respectively. Resistors can also be added to the signal output line before LMG1020-Q1 depending on the input signal pulse width to provide additional RC filtering. [Figure 7-4](#) presents the schematic using approach A with the preferred filtering method. Approach B as [Figure 7-3](#) places the current sense resistor within the gate drive loop path. In this case, the LMG1020-Q1 GND pin is connected to the signal ground, and with good ground plane connection, the ground bounce issue can be less severe than approach A. However, the inductance of the current sense resistor adds common-source inductance to the gate drive loop. The voltage generated across this parasitic inductance will subtract from the gate-drive voltage of the FET, slowing down the

turnon and turnoff di/dt of the FET, or even cause mis-turn on and off. Additional gate resistance will have to be added to ensure the loop is stable and ring-free. The slower rise may negate the advantage of the fast switching of the GaN FET and may cause additional losses in the circuit. Therefore, this approach is not recommended.

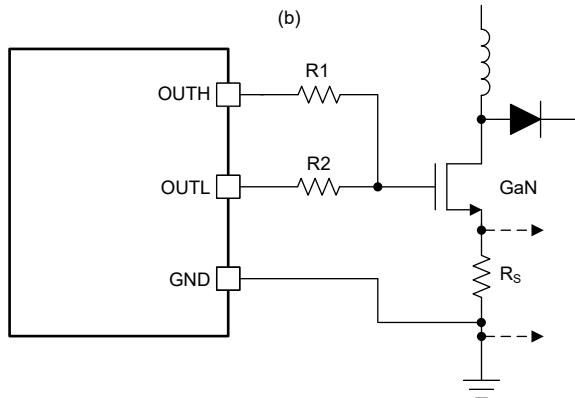

Figure 7-2. Source Resistor Current Sense A Configuration

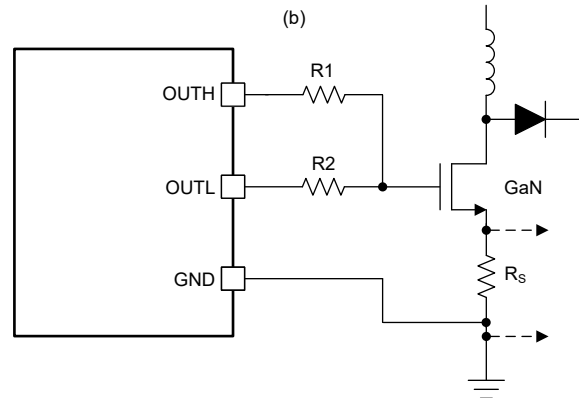

Figure 7-3. Source Resistor Current Sense B Configuration

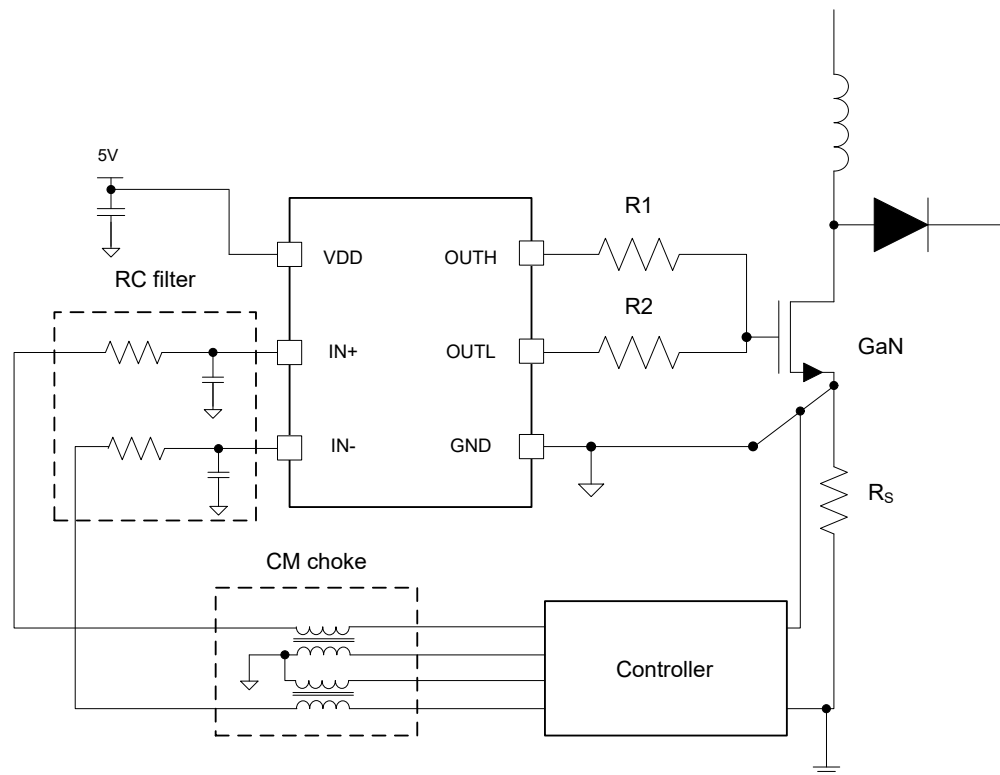

Figure 7-4. Filtering For Ground Bounce Noise Handling When Using LMG1020-Q1

7.2.2.2 Creating Nanosecond Pulse With LMG1020-Q1

LMG1020-Q1 can be used to drive pulses of nano seconds duration on to a capacitive load. LMG1020-Q1 can be driven with a equivalently short pulse on one input pin. However, this takes a sufficiently strong digital driver and careful consideration of the routing parasitics from digital output to input of LMG1020-Q1. Two inputs and included NAND gate in LMG1020-Q1 provide an alternate method to create a short pulse at the LMG1020-Q1 output. Starting with both IN+ and IN- at low, taking IN+ high will cause the output to go high. Now if IN- is taken high as well, output will be pulled low. So a digital signal and its delayed version can be applied to IN+

and IN– respectively to create a pulse at the output with width corresponding to the delay between the signals, as shown in Figure 7-5. The delay can be digitally controlled in the nanosecond range. This method alleviates the requirements for driving the input of LMG1020-Q1. If a separate delayed version of the digital signal is not available, a RC delay followed by a buffer can be used to derive the second signal. Optionally, if LMG1020-Q1 must be driven with a single short duration pulse, that pulse can itself be generated using another LMG1020-Q1 by the above method to meet drive requirements.

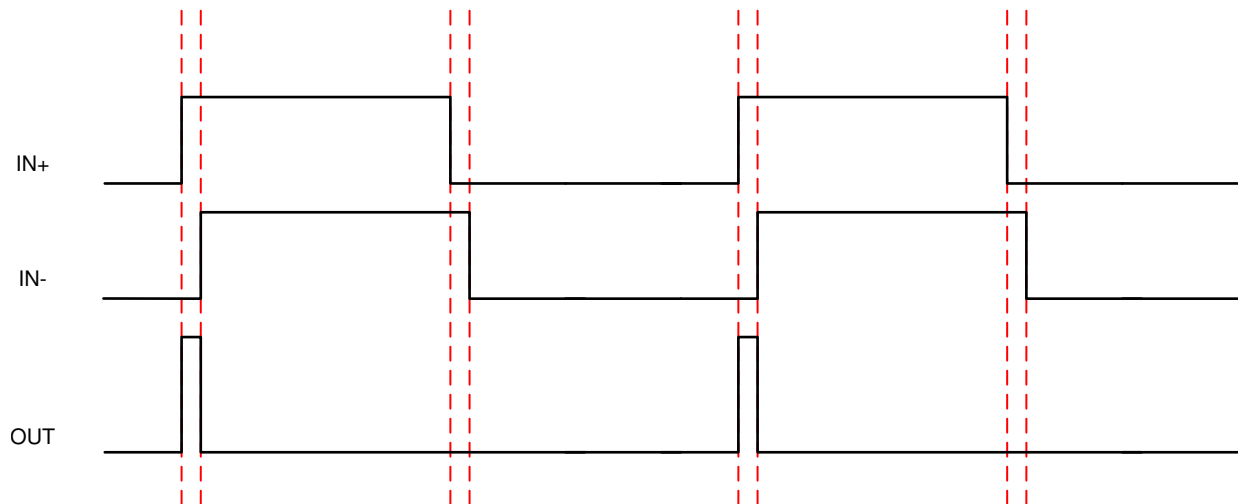

Figure 7-5. Timing Diagram To Create Short Pulses

7.2.3 VDD and Overshoot

Fast switching with high current is prone to ringing with parasitic inductances, including those on PCB traces. Overshoot associated with such ringing transients need to be evaluated and controlled as a part of the PCB design process to limit device stress. The parameters affecting stress are how high the overshoot is above the absolute maximum specification and the ratio of overshoot duration to the switching time period. Recommended design practice is to limit the overshoots to the absolute maximum pin voltages. This is accomplished with careful PCB layout to minimize parasitic inductances, choice of components with low ESL and addition of series resistance to limit rise times. For large overshoots, limiting the variability of the power supply may be required. For example, 0.5V of overshoot will be permissible with a maximum recommended supply of 5.25V (5% variability); however, for larger overshoots, a supply with lower variability will be preferred.

7.2.4 Operating at Higher Frequency

With fast rise/fall time, and capability of achieving 1ns pulse width, depending on the capacitive load condition, the operating frequency of LMG1020-Q1 can be increased in a burst manner. In conditions which requires very high frequency pulsing, a pulse train with certain period of pause between each burst can be adopted to avoid overheat of the device. This will help maintain the RMS output current similar as lower frequency operation but boost the transient frequency to very high. In addition, higher decoupling capacitance will be needed to supply high frequency charging of the capacitive load.

7.2.5 Application Curves

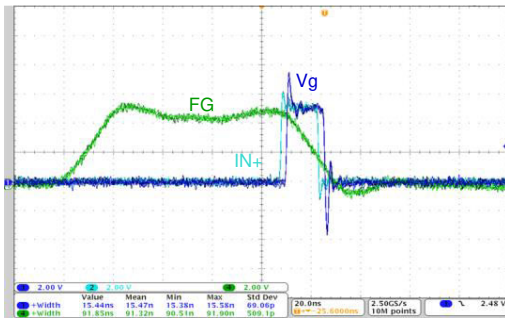

Figure 7-6. 90ns Pulse from Function Generator Yielding 15ns Pulse on the Input (cyan) and Gate (blue) After Pulse Shortening

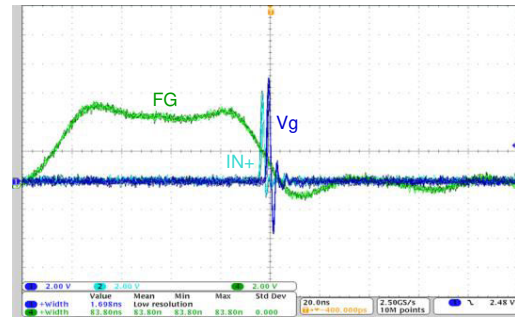

Figure 7-7. 90ns Pulse from Function Generator Yielding 1.5ns Pulse on the Input (cyan) and Gate (blue) After Pulse Shortening

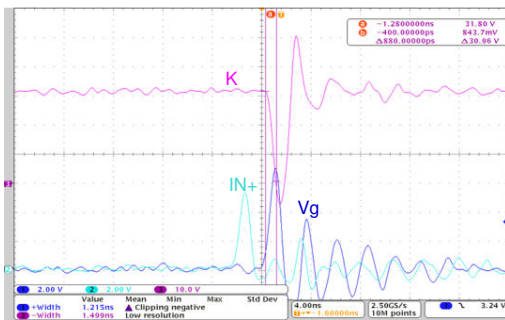

Figure 7-8. 1.2ns Gate Pulse Yielding 1.5ns 30V Into 1Ω Pulse (500MHz scope)



Figure 7-9. V_{DS} for 1.5ns Pulse with 40V of Bus Voltage

Figure 7-6 and Figure 7-7 are the waveforms showing the pulse short pulse generation and input/output pulses. The 90ns long pulse (in green color) and its delayed signal are sent through an NAND gate, which outputs a short pulse signal as the input of LMG1020-Q1. The output signal (in blue color) follows the input (in cyan color) with certain propagation delay. An output pulse short as 1.5ns can be obtained as Figure 7-7.

Figure 7-8 is taken with a 500MHz oscilloscope and shows typical operation waveforms, including the input logic gating signal (cyan), gate signal (blue), and drain to source signal (pink) of the switching GaN FET. On the drain waveform of the FET, it is possible to see a 20V overshoot. This is due to the inductance in the power loop. Vg seems to be oscillating, but this is caused by pickup noise, which is inevitable even when using a spring ground connection.

Figure 7-9 shows the waveform of drain to source voltage of a FET driven by LMG1020-Q1 with 1.5ns pulse width and 300ps fall time, which drives maximum 60A current at 40V bus voltage.

7.3 Power Supply Recommendations

A low-ESR/ESL ceramic capacitor must be connected close to the IC, between V_{DD} and GND pins to support the high peak current being drawn from V_{DD} during turnon of the FETs. It is most desirable to place the V_{DD} decoupling capacitor on the same side of the PC board as the driver. The inductance of via holes can impose excessive ringing on the IC pins.

TI recommends the use of a three-terminal capacitor connecting in shunt-through manner to achieve the lowest ESL and best transient performance. This capacitor can be placed as close as possible to the IC, while another capacitor in larger capacitance can be placed closely to the three-terminal cap to supply enough charge but with slightly lower bandwidth. As a general practice, the combination of a 0.1 μ F of 0402 or feed-through capacitor (closest to LMG1020-Q1) and a 1 μ F 0603 capacitor is recommended.

7.4 Layout

7.4.1 Layout Guidelines

The layout of the LMG1020-Q1 is critical to its performance and functionality. The LMG1020-Q1 is available in a WCSP ball-grid array package, which enables low-inductance connection to a BGA-type GaN FET. [Figure 7-10](#) shows the recommended layout of the LMG1020-Q1 with a ball-grid array GaN FET. [Figure 7-11](#) presents a layout of LMG1020-Q1 with a 0.1 μ F feed-through capacitor and a larger 1 μ F capacitor.

A four-layer or higher layer count board is required to reduce the parasitic inductances of the layout to achieve suitable performance. To minimize inductance and board space, resistors and capacitors in the 0201 package are used here. The gate drive power loss must be calculated to ensure an 0201 resistor will be able to handle the power level.

7.4.1.1 Gate Drive Loop Inductance and Ground Connection

A compact, low-inductance gate-drive loop is essential to achieving fast switching frequencies with the LMG1020-Q1. The LMG1020-Q1 should be placed as close to the GaN FET as possible, with gate drive resistors R1 and R2 immediately connecting OUTH and OUTL to the FET gate. Large traces must be used to minimize resistance and parasitic inductance.

To minimize gate drive loop inductance, the source return should be on layer 2 of the PCB, immediately under the component (top) layer. Vias immediately adjacent to both the FET source and the LMG1020-Q1 GND pin connect to this plane with minimal impedance. Finally, take care to connect the GND plane to the source power plane only at the FET to minimize common-source inductance and to reduce coupling to the ground plane.

7.4.1.2 Bypass Capacitor

The VDD power terminal of the LMG1020-Q1 must be bypassed to ground immediately adjacent to the IC. Because of the fast gate drive of the IC, the placement and value of the bypass capacitor is critical. The bypass capacitor must be placed on the top layer, as close as possible to the IC, and connected to both VDD and GND using large power planes. This bypass capacitor has to be at least a 0.1 μ F, up to 1 μ F, with temperature coefficient X7R or better. Recommended body types are Low Inductance Chip Capacitor (LICC), Inter-Digitated Capacitor (IDC), Feed-through, and LGA. Finally, an additional 1 μ F capacitor (not shown in [Figure 7-10](#)) must be placed as close to the IC as practical.

7.4.2 Layout Example

[Figure 7-10](#) presents a typical layout of LMG1020-Q1 with a 0402 decoupling capacitor C1, which is placed as close as possible to LMG1020-Q1. The ground return at GaN FET Kelvin source immediately flows through a via to the closest inner layer, and overlaps with the top layer traces.

[Figure 7-11](#) presents a layout of LMG1020-Q1 with a 0.1 μ F feed-through capacitor (C1) and a larger 1 μ F capacitor (C3) for decoupling. In this design, the feed-through capacitor C1 is placed in a shunt-through manner for lower noise decoupling, and C3 is placed next to C1. 0201 resistors are used at the output of LMG1020-Q1, which brings lower parasitic inductance than 0402 package.

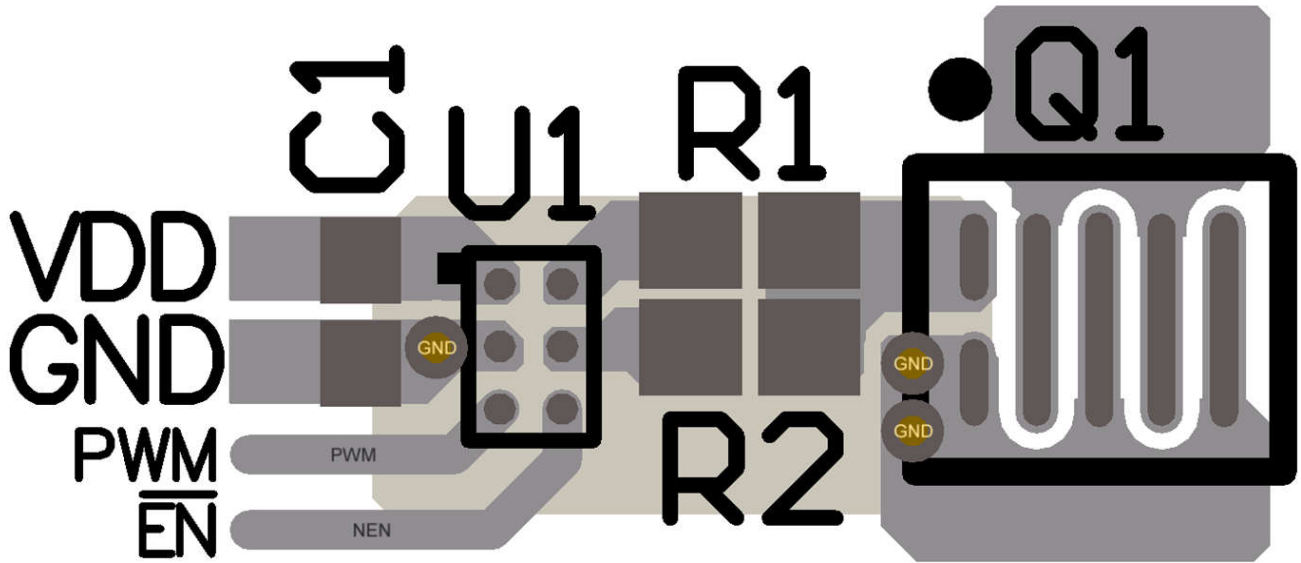

Figure 7-10. Typical LMG1020-Q1 Layout With Ball-Grid GaN FET And 0402 Decoupling Capacitor

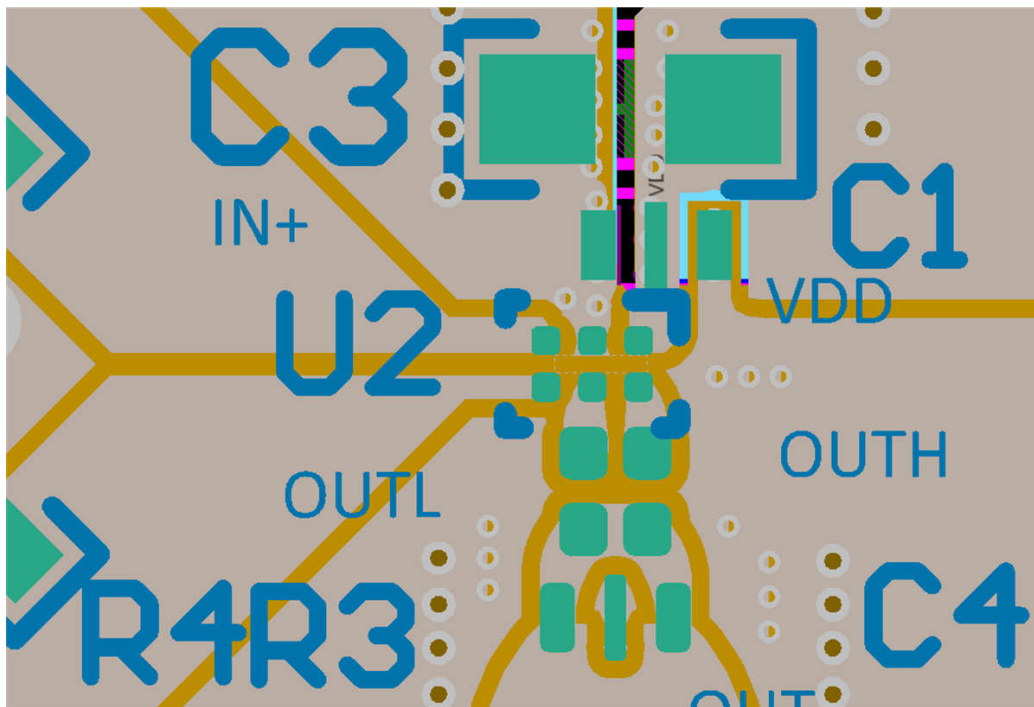

Figure 7-11. Typical Layout Of LMG1020-Q1 And A Feed-Through Decoupling Capacitor With A Capacitor Load

8 Device and Documentation Support

8.1 Third-Party Products Disclaimer

TI'S PUBLICATION OF INFORMATION REGARDING THIRD-PARTY PRODUCTS OR SERVICES DOES NOT CONSTITUTE AN ENDORSEMENT REGARDING THE SUITABILITY OF SUCH PRODUCTS OR SERVICES OR A WARRANTY, REPRESENTATION OR ENDORSEMENT OF SUCH PRODUCTS OR SERVICES, EITHER ALONE OR IN COMBINATION WITH ANY TI PRODUCT OR SERVICE.

8.2 Documentation Support

8.2.1 Related Documentation

For related documentation see the following:

-
- [Using the LMG1020-EVM Nano-second LiDAR EVM](#) (SNOU150)
- [LMG1020 PSpice Transient Model](#) (SNOM618)
- [LMG1020 TINA-TI Reference Design](#) (SNOM619)
- [LMG1020 TINA-TI Transient Spice Model](#) (SNOM620)
- [LMG1020EVM Altium Design Files](#) (SNOR025)

8.3 Receiving Notification of Documentation Updates

To receive notification of documentation updates, navigate to the device product folder on ti.com. Click on *Notifications* to register and receive a weekly digest of any product information that has changed. For change details, review the revision history included in any revised document.

8.4 Support Resources

TI E2E™ [support forums](#) are an engineer's go-to source for fast, verified answers and design help — straight from the experts. Search existing answers or ask your own question to get the quick design help you need.

Linked content is provided "AS IS" by the respective contributors. They do not constitute TI specifications and do not necessarily reflect TI's views; see TI's [Terms of Use](#).

8.5 Trademarks

TI E2E™ is a trademark of Texas Instruments.
All trademarks are the property of their respective owners.

8.6 Electrostatic Discharge Caution



This integrated circuit can be damaged by ESD. Texas Instruments recommends that all integrated circuits be handled with appropriate precautions. Failure to observe proper handling and installation procedures can cause damage.

ESD damage can range from subtle performance degradation to complete device failure. Precision integrated circuits may be more susceptible to damage because very small parametric changes could cause the device not to meet its published specifications.

8.7 Glossary

[TI Glossary](#) This glossary lists and explains terms, acronyms, and definitions.

9 Revision History

NOTE: Page numbers for previous revisions may differ from page numbers in the current version.

DATE	REVISION	NOTES
April 2025	*	Initial Release

10 Mechanical, Packaging, and Orderable Information

The following pages include mechanical, packaging, and orderable information. This information is the most current data available for the designated devices. This data is subject to change without notice and revision of this document. For browser-based versions of this data sheet, refer to the left-hand navigation.

PACKAGING INFORMATION

Orderable part number	Status (1)	Material type (2)	Package Pins	Package qty Carrier	RoHS (3)	Lead finish/ Ball material (4)	MSL rating/ Peak reflow (5)	Op temp (°C)	Part marking (6)
LMG1020QYBVRQ1	Active	Production	DSBGA (YBV) 6	3000 LARGE T&R	Yes	Call TI	Level-1-260C-UNLIM	-40 to 125	20Q

(1) **Status:** For more details on status, see our [product life cycle](#).

(2) **Material type:** When designated, preproduction parts are prototypes/experimental devices, and are not yet approved or released for full production. Testing and final process, including without limitation quality assurance, reliability performance testing, and/or process qualification, may not yet be complete, and this item is subject to further changes or possible discontinuation. If available for ordering, purchases will be subject to an additional waiver at checkout, and are intended for early internal evaluation purposes only. These items are sold without warranties of any kind.

(3) **RoHS values:** Yes, No, RoHS Exempt. See the [TI RoHS Statement](#) for additional information and value definition.

(4) **Lead finish/Ball material:** Parts may have multiple material finish options. Finish options are separated by a vertical ruled line. Lead finish/Ball material values may wrap to two lines if the finish value exceeds the maximum column width.

(5) **MSL rating/Peak reflow:** The moisture sensitivity level ratings and peak solder (reflow) temperatures. In the event that a part has multiple moisture sensitivity ratings, only the lowest level per JEDEC standards is shown. Refer to the shipping label for the actual reflow temperature that will be used to mount the part to the printed circuit board.

(6) **Part marking:** There may be an additional marking, which relates to the logo, the lot trace code information, or the environmental category of the part.

Multiple part markings will be inside parentheses. Only one part marking contained in parentheses and separated by a "-" will appear on a part. If a line is indented then it is a continuation of the previous line and the two combined represent the entire part marking for that device.

Important Information and Disclaimer:The information provided on this page represents TI's knowledge and belief as of the date that it is provided. TI bases its knowledge and belief on information provided by third parties, and makes no representation or warranty as to the accuracy of such information. Efforts are underway to better integrate information from third parties. TI has taken and continues to take reasonable steps to provide representative and accurate information but may not have conducted destructive testing or chemical analysis on incoming materials and chemicals. TI and TI suppliers consider certain information to be proprietary, and thus CAS numbers and other limited information may not be available for release.

In no event shall TI's liability arising out of such information exceed the total purchase price of the TI part(s) at issue in this document sold by TI to Customer on an annual basis.

OTHER QUALIFIED VERSIONS OF LMG1020-Q1 :

- Catalog : [LMG1020](#)

NOTE: Qualified Version Definitions:

- Catalog - TI's standard catalog product

TAPE AND REEL INFORMATION

QUADRANT ASSIGNMENTS FOR PIN 1 ORIENTATION IN TAPE

*All dimensions are nominal

Device	Package Type	Package Drawing	Pins	SPQ	Reel Diameter (mm)	Reel Width W1 (mm)	A0 (mm)	B0 (mm)	K0 (mm)	P1 (mm)	W (mm)	Pin1 Quadrant
LMG1020QYBVRQ1	DSBGA	YBV	6	3000	180.0	13.2	0.98	1.35	0.56	4.0	8.0	Q1

TAPE AND REEL BOX DIMENSIONS

*All dimensions are nominal

Device	Package Type	Package Drawing	Pins	SPQ	Length (mm)	Width (mm)	Height (mm)
LMG1020QYBVRQ1	DSBGA	YBV	6	3000	220.0	220.0	35.0

YBV0006

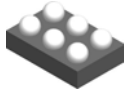

PACKAGE OUTLINE

DSBGA - 0.45 mm max height

DIE SIZE BALL GRID ARRAY

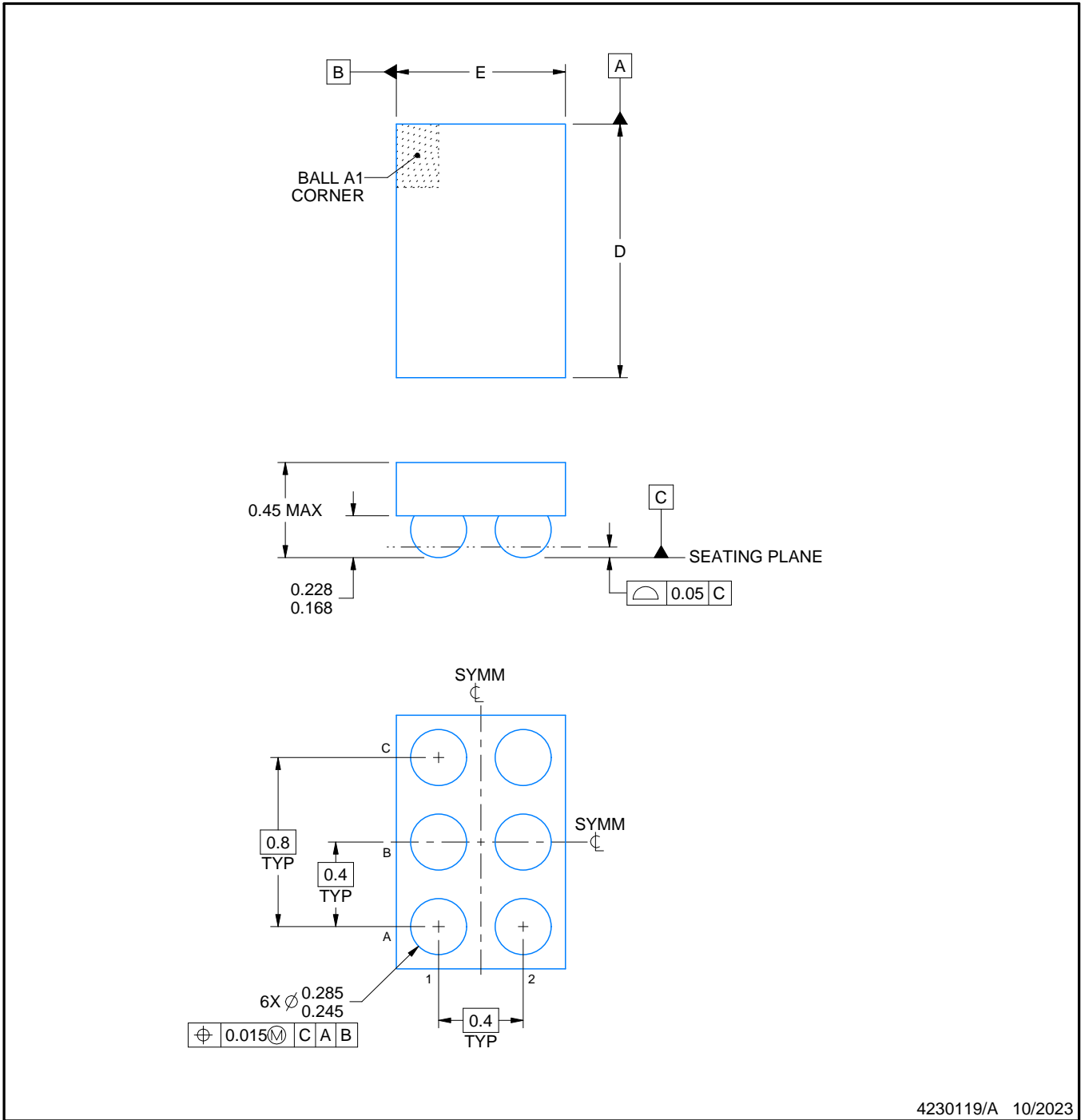

NOTES:

1. All linear dimensions are in millimeters. Any dimensions in parenthesis are for reference only. Dimensioning and tolerancing per ASME Y14.5M.
2. This drawing is subject to change without notice.

EXAMPLE BOARD LAYOUT

YBV0006

DSBGA - 0.45 mm max height

DIE SIZE BALL GRID ARRAY

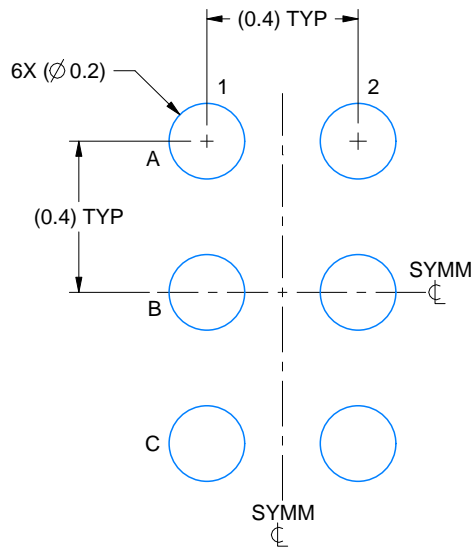

LAND PATTERN EXAMPLE
EXPOSED METAL SHOWN
SCALE: 50X

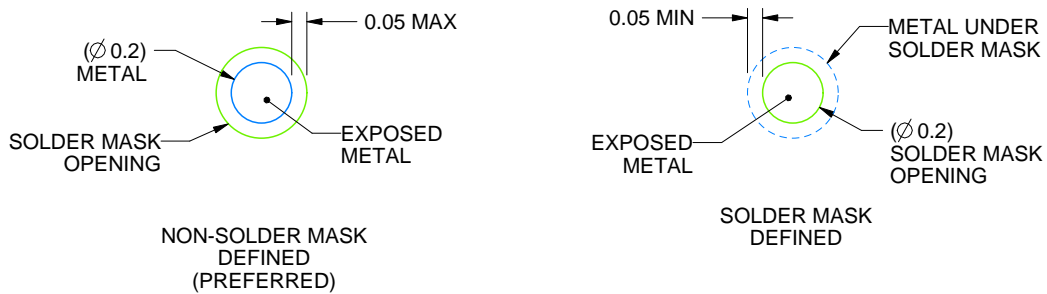

SOLDER MASK DETAILS
NOT TO SCALE

4230119/A 10/2023

NOTES: (continued)

- Final dimensions may vary due to manufacturing tolerance considerations and also routing constraints. See Texas Instruments Literature No. SNVA009 (www.ti.com/lit/snva009).

EXAMPLE STENCIL DESIGN

YBV0006

DSBGA - 0.45 mm max height

DIE SIZE BALL GRID ARRAY

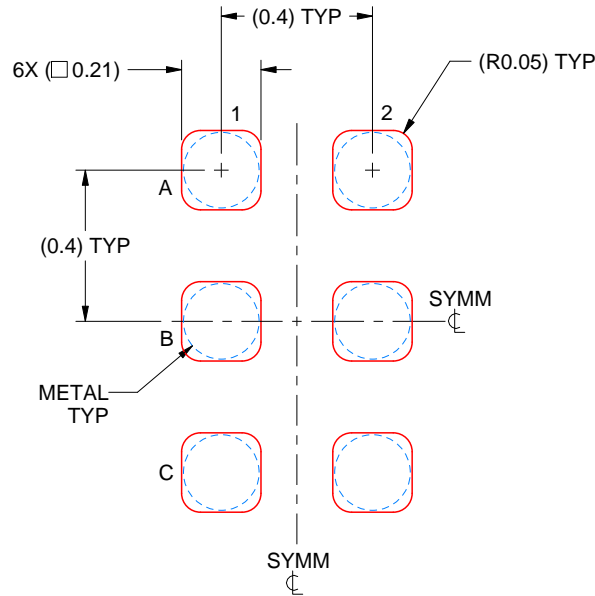

SOLDER PASTE EXAMPLE
BASED ON 0.1 mm THICK STENCIL
SCALE: 50X

4230119/A 10/2023

NOTES: (continued)

4. Laser cutting apertures with trapezoidal walls and rounded corners may offer better paste release.

IMPORTANT NOTICE AND DISCLAIMER

TI PROVIDES TECHNICAL AND RELIABILITY DATA (INCLUDING DATASHEETS), DESIGN RESOURCES (INCLUDING REFERENCE DESIGNS), APPLICATION OR OTHER DESIGN ADVICE, WEB TOOLS, SAFETY INFORMATION, AND OTHER RESOURCES "AS IS" AND WITH ALL FAULTS, AND DISCLAIMS ALL WARRANTIES, EXPRESS AND IMPLIED, INCLUDING WITHOUT LIMITATION ANY IMPLIED WARRANTIES OF MERCHANTABILITY, FITNESS FOR A PARTICULAR PURPOSE OR NON-INFRINGEMENT OF THIRD PARTY INTELLECTUAL PROPERTY RIGHTS.

These resources are intended for skilled developers designing with TI products. You are solely responsible for (1) selecting the appropriate TI products for your application, (2) designing, validating and testing your application, and (3) ensuring your application meets applicable standards, and any other safety, security, regulatory or other requirements.

These resources are subject to change without notice. TI grants you permission to use these resources only for development of an application that uses the TI products described in the resource. Other reproduction and display of these resources is prohibited. No license is granted to any other TI intellectual property right or to any third party intellectual property right. TI disclaims responsibility for, and you fully indemnify TI and its representatives against any claims, damages, costs, losses, and liabilities arising out of your use of these resources.

TI's products are provided subject to [TI's Terms of Sale](#), [TI's General Quality Guidelines](#), or other applicable terms available either on ti.com or provided in conjunction with such TI products. TI's provision of these resources does not expand or otherwise alter TI's applicable warranties or warranty disclaimers for TI products. Unless TI explicitly designates a product as custom or customer-specified, TI products are standard, catalog, general purpose devices.

TI objects to and rejects any additional or different terms you may propose.

Copyright © 2026, Texas Instruments Incorporated

Last updated 10/2025