

## MSPM0L2116/7 and MSPM0L1126/7 Mixed-Signal Microcontrollers

### 1 Features

- Core
  - Arm® 32-bit Cortex®-M0+ CPU with memory protection unit, frequency up to 32MHz
- Operating characteristics
  - Extended temperature: –40°C up to 125°C
  - Wide supply voltage range: 1.62V to 3.6V
- Memories
  - Up to 128KB of flash memory with error correction code (ECC)
  - 12KB of SRAM with ECC or parity
- User interface
  - Ultra-low power segmented LCD controller supporting up to 4x48 and 8x44 LCD displays
- High-performance analog peripherals
  - 12-bit 1.6Msps analog-to-digital converter (ADC), up to 26 external channels
  - Configurable 1.4V or 2.5V internal shared voltage reference (VREF)
  - Comparator (COMP) with 8-bit reference DAC
  - Integrated temperature sensor
- Optimized low-power modes
  - RUN: 98µA/MHz (CoreMark)
  - SLEEP: 1.3mA at 32MHz
  - STOP: 403µA at 4MHz
  - STANDBY 1.6µA with SRAM and registers fully retained
  - SHUTDOWN: 81nA with I/O wake-up capability
- Intelligent digital peripherals
  - 3-channel DMA controller
  - 15-channel event fabric signaling system
  - Up to eight timers supporting up to 16 PWM outputs, seven are operational down to STANDBY mode
    - One 16-bit advanced timer with deadband and the timer frequency up to 64Mhz
    - One 16-bit general purpose timer with 4 capture/compares
    - Two 16-bit general-purpose timers with 2 capture/compares
    - Four 16-bit basic timers
  - Window-watchdog timer (WWDT)
  - Independent watchdog timer (IWDT)
- Communication interfaces
  - Up to three UART modules, with one supporting LIN, IrDA, DALI, smart card, Manchester
  - Up to two I<sup>2</sup>C modules supporting SMBus/PMBus and wakeup from STOP mode, supporting up to FM+ (1Mbps)
    - Up to two SPI module supporting up to 16Mbps
  - Clock system
    - Internal 32MHz oscillator with -2.1% to 1.6% accuracy (SYSOSC)
    - Internal 32kHz oscillator (LFOSC) with ±3% accuracy
    - External 4MHz to 32MHz crystal oscillator (HFXT)
    - External 32kHz crystal oscillator (LFXT)
    - External Low Frequency (LF) and High Frequency (HF) digital clock inputs
    - Digital clock output
  - Data integrity and encryption
    - Cyclic redundancy checker (CRC-16)
    - AES accelerator with support for GCM/GMAC, CCM/CBC-MAC, CBC, CTR
    - Secure key storage for one 256-bit AES key or two 128-bit AES keys
  - Flexible I/O features
    - Up to 60 total GPIOs
    - Two 5V-tolerant open-drain IOs
  - Development support
    - 2-pin serial wire debug (SWD)
  - Package options
    - 64-pin LQFP (PM)
    - 48-pin LQFP (PT), VQFN (RGZ)
    - 32-pin VQFN (RHB)
    - 28-pin VSSOP (DGS28), WQFN-28 (RUY)
    - 24-pin VQFN (RGE)
  - Family members
    - MSPM0L2117: 128KB of flash, 12KB of RAM, LCD
    - MSPM0L2116: 64KB of flash, 12KB of RAM, LCD
    - MSPM0L1127: 128KB of flash, 12KB of RAM
    - MSPM0L1126: 64KB of flash, 12KB of RAM
  - Development kits and software (also see [Tools and Software](#))
    - LP-MSPM0L2117 LaunchPad™ development kit
    - MSP Software Development Kit (SDK)

### 2 Applications

- [Battery charging and management](#)
- [Power supplies and power delivery](#)
- [Personal electronics](#)
- [Building security and fire safety](#)
- [Connected peripherals and printers](#)
- [Grid infrastructure](#)
- [Smart metering](#)
- [Communication modules](#)
- [Medical and healthcare](#)



- [Lighting](#)

### 3 Description

MSPM0L2116/7 and MSPM0L1126/7 microcontrollers (MCUs) are part of MSP's highly integrated, ultra-low-power 32-bit MSPM0 MCU family. The microcontrollers are based on the Arm® Cortex®-M0+ 32-bit core platform, operating at up to 32MHz frequency. These cost-optimized MCUs offer high-performance analog peripheral integration, support extended temperature ranges from -40°C to 125°C, and operate with supply voltages from 1.62V to 3.6V.

The MSPM0L2116/7 and MSPM0L1126/7 devices provide up to 128KB embedded flash program memory with built in error correction code (ECC) and 12KB SRAM with ECC and parity protection. These MCUs incorporate a high-speed on-chip oscillator with an accuracy from -2.1% to +1.6%, eliminating the need for an external crystal.

An ultra-low power segmented LCD controller (on MSPM0L2116/7 devices) supports driving LCD glass with up to 52 pins in a variety of mux and bias configurations, enabling low cost displays.

Flexible cybersecurity enablers can be used to support secure boot, IP protection (execute-only memory), key storage, and more. Hardware acceleration is provided for a variety of 128/256-bit AES symmetric cipher modes.

Additional features include a 3-channel DMA, CRC-16 accelerator, and a variety of high-performance analog peripherals such as one 12-bit 1.6Msps ADC with VDD as the voltage reference, a comparator with 8-bit reference DAC and an on-chip temperature sensor. These devices also offer intelligent digital peripherals such as one 16-bit advanced timer with deadband and timer frequency up to 64MHz, three 16-bit general purpose timer, four basic timers, one windowed watchdog timer, and a variety of communication peripherals supporting up to three UART, two SPI, and two I2C. These communication peripherals offer protocol support for LIN, IrDA, DALI, Manchester, smart card, SMBus, and PMBus.

The TI MSPM0 family of low-power MCUs consists of devices with varying degrees of analog and digital integration allowing for customers find the MCU that meets the project's needs. The MSPM0 MCU platform combines the Arm Cortex-M0+ platform with a holistic ultra-low-power system architecture, allowing system designers to increase performance while reducing energy consumption.

MSPM0L2116/7 and MSPM0L1126/7 MCUs are supported by an extensive hardware and software ecosystem with reference designs and code examples to get the design started quickly. Development kits include a [LaunchPad](#) available for purchase. TI also provides a free MSP Software Development Kit (SDK), which is available as a component of [Code Composer Studio™ IDE](#) desktop and cloud version within the [TI Resource Explorer](#). MSPM0 MCUs are also supported by extensive online collateral, training with [MSP Academy](#), and online support through the [TI E2E™ support forums](#).

For complete module descriptions, see the [MSPM0 L-Series 32MHz Microcontrollers Technical Reference Manual](#).

**Table 3-1. Package Information**

PART NUMBER	PACKAGE	PACKAGE SIZE
MSPM0L2117SPMR	PM (LQFP, 64)	12mm × 12mm
MSPM0L2116SPMR		
MSPM0L1127SPMR		
MSPM0L1126SPMR		
MSPM0L2117SPTR	PT (LQFP, 48)	9mm × 9mm
MSPM0L2116SPTR		
MSPM0L1127SPTR		
MSPM0L1126SPTR		
MSPM0L2117SRGZR	RGZ (VQFN, 48)	7mm × 7mm
MSPM0L2116SRGZR		
MSPM0L1127SRGZR		
MSPM0L1126SRGZR		

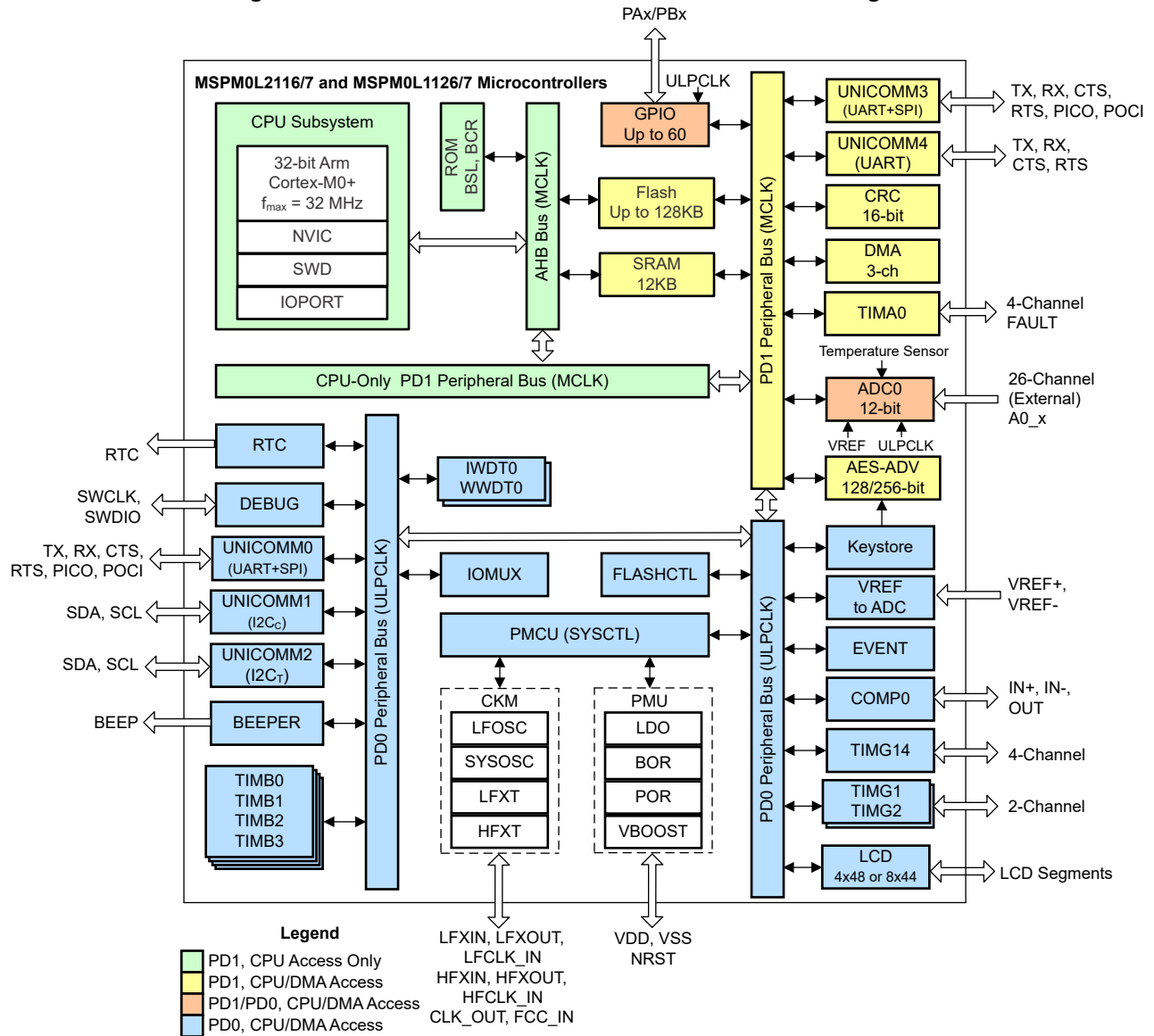
**Table 3-1. Package Information (continued)**

PART NUMBER	PACKAGE	PACKAGE SIZE
MSPM0L2117SRHBR	RHB (VQFN, 32)	5mm x 5mm
MSPM0L2116SRHBR		
MSPM0L1127SRHBR		
MSPM0L1126SRHBR		
MSPM0L2117S28DGSR	DGS (VSSOP, 28)	7.1mm × 4.9mm
MSPM0L2116S28DGSR		
MSPM0L1127SDGS28R		
MSPM0L1126SDGS28R		
MSPM0L2117SRUYR	RUY (WQFN, 28)	4mm x 4mm
MSPM0L2116SRUYR		
MSPM0L1127SRUYR		
MSPM0L1126SRUYR		
MSPM0L2117SRGER	RGE (VQFN, 24)	4mm × 4mm
MSPM0L2116SRGER		
MSPM0L1127SRGER		
MSPM0L1126SRGER		

## 4 Functional Block Diagram

MSPM0L2116/7 and MSPM0L1126/7 Block Diagram shows the functional block diagram.

**Figure 4-1. MSPM0L2116/7 and MSPM0L1126/7 Block Diagram**



## Table of Contents

<b>1 Features</b> .....	1	8.9 SRAM.....	61
<b>2 Applications</b> .....	1	8.10 GPIO.....	61
<b>3 Description</b> .....	2	8.11 IOMUX.....	62
<b>4 Functional Block Diagram</b> .....	4	8.12 ADC.....	62
<b>5 Device Comparison</b> .....	6	8.13 Temperature Sensor.....	63
<b>6 Pin Configuration and Functions</b> .....	7	8.14 LFSS.....	63
6.1 Pin Diagrams.....	7	8.15 IWDTC.....	63
6.2 Pin Attributes.....	12	8.16 RTC_B.....	63
6.3 Signal Descriptions.....	24	8.17 VREF.....	64
6.4 Connections for Unused Pins.....	32	8.18 COMP.....	65
<b>7 Specifications</b> .....	34	8.19 Security.....	66
7.1 Absolute Maximum Ratings.....	34	8.20 AESADV.....	66
7.2 ESD Ratings.....	34	8.21 CRC.....	67
7.3 Recommended Operating Conditions.....	34	8.22 Keystore.....	67
7.4 Thermal Information.....	35	8.23 UNICOMM (UART/I <sup>2</sup> C/SPI).....	67
7.5 Supply Current Characteristics.....	37	8.24 WWDT.....	69
7.6 Power Supply Sequencing.....	37	8.25 Timers (TIMx).....	70
7.7 Flash Memory Characteristics.....	39	8.26 LCD.....	71
7.8 Timing Characteristics.....	39	8.27 Device Analog Connections.....	72
7.9 Clock Specifications.....	40	8.28 Input/Output Diagrams.....	73
7.10 <i>Digital IO</i> .....	42	8.29 DEBUGSS.....	74
7.11 Analog Mux VBOOST.....	44	8.30 Serial Wire Debug Interface.....	74
7.12 ADC.....	44	8.31 Bootstrap Loader (BSL).....	74
7.13 Temperature Sensor.....	46	8.32 Device Factory Constants.....	75
7.14 VREF.....	47	8.33 Identification.....	76
7.15 <i>Comparator (COMP)</i> .....	47	<b>9 Applications, Implementation, and Layout</b> .....	77
7.16 LCD.....	48	9.1 Typical Application.....	77
7.17 <i>I2C</i> .....	50	<b>10 Device and Documentation Support</b> .....	78
7.18 <i>SPI</i> .....	51	10.1 Getting Started and Next Steps.....	78
7.19 UART.....	53	10.2 Device Nomenclature.....	78
7.20 TIMx.....	53	10.3 Tools and Software.....	79
7.21 Emulation and Debug.....	53	10.4 Documentation Support.....	79
<b>8 Detailed Description</b> .....	54	10.5 Support Resources.....	80
8.1 CPU.....	54	10.6 Trademarks.....	80
8.2 Operating Modes.....	54	10.7 Electrostatic Discharge Caution.....	80
8.3 Power Management Unit (PMU).....	56	10.8 Glossary.....	80
8.4 Clock Module (CKM).....	56	<b>11 Revision History</b> .....	80
8.5 DMA Trigger Mapping.....	57	<b>12 Mechanical, Packaging, and Orderable Information</b> .....	81
8.6 Events.....	58	12.1 Mechanical Data.....	81
8.7 Memory.....	59		
8.8 Flash Memory.....	61		

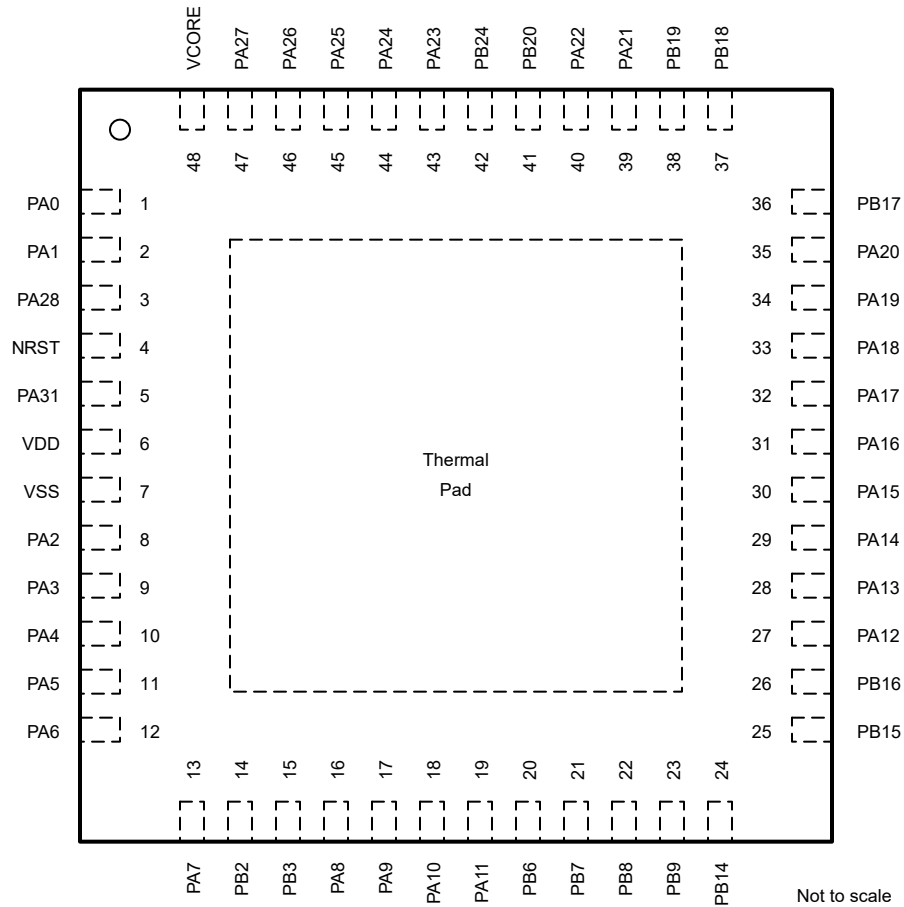
## 5 Device Comparison

**Table 5-1. Device Comparison Table**

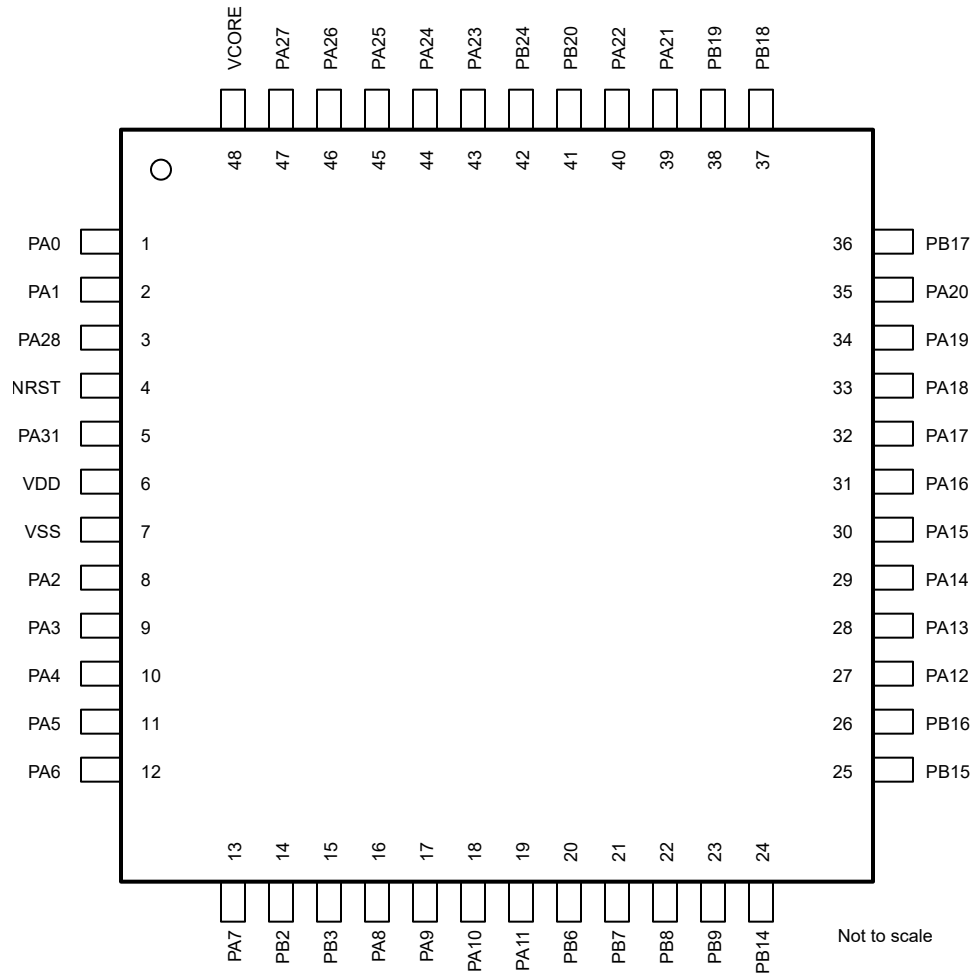
DEVICE NAME <sup>(1) (2)</sup>	FLASH / SRAM (KB)	ADC CHANNEL	LCD Segments	TIMA / TIMG / TIMB	GPIO	COMP	PACKAGE <sup>(3)</sup>
MSPM0L2117SPMR	128 / 12	25	4 x 48	1 / 3 / 4	60	1	64 LQFP (12mm x 12mm)
MSPM0L2116SPMR	64 / 12		8 x 44				
MSPM0L1127SPMR	128 / 12		-				
MSPM0L1126SPMR	64 / 12		-				
MSPM0L2117SPTR	128 / 12	21	4 x 34	1 / 3 / 4	44	1	48 LQFP (9mm x 9mm)
MSPM0L2116SPTR	64 / 12		8 x 30				
MSPM0L1127SPTR	128 / 12		-				
MSPM0L1126SPTR	64 / 12		-				
MSPM0L2117SRGZR	128 / 12	21	4 x 34	1 / 3 / 4	44	1	48 VQFN (7mm x 7mm)
MSPM0L2116SRGZR	64 / 12		8 x 30				
MSPM0L1127SRGZR	128 / 12		-				
MSPM0L1126SRGZR	64 / 12		-				
MSPM0L2117SRHBR	128 / 12	14	4 x 19	1 / 3 / 4	28	1	32 VQFN(5mm x 5mm)
MSPM0L2116SRHBR	64 / 12		8 x 15				
MSPM0L1127SRHBR	128 / 12		-				
MSPM0L1126SRHBR	64 / 12		-				
MSPM0L2117S28DGSR	128 / 12	12	4 x 16	1 / 3 / 4	24	1	28 VSSOP (7.1mm x 4.9mm)
MSPM0L2116S28DGSR	64 / 12		8 x 14				
MSPM0L1127S28DGSR	128 / 12		-				
MSPM0L1126S28DGSR	64 / 12		-				
MSPM0L2117SRUYR	128 / 12	13	4 x 15	1 / 3 / 4	24	1	28 WQFN(4mm x 4mm)
MSPM0L2116SRUYR	64 / 12		8 x 11				
MSPM0L1127SRUYR	128 / 12		-				
MSPM0L1126SRUYR	64 / 12		-				
MSPM0L2117SRGER	128 / 12	9	4 x 10	1 / 3 / 4	20	1	24 VQFN (4mm x 4mm)
MSPM0L2116SRGER	64 / 12		8 x 6				
MSPM0L1127SRGER	128 / 12		-				
MSPM0L1126SRGER	64 / 12		-				

- (1) For the most current part, package, and ordering information for all available devices, see the *Package Option Addendum*, or see the [TI website](#).
- (2) Device Qualifications:  
 • S = -40°C to 125°C
- (3) The sizes shown here are approximations. For the package dimensions with tolerances, see the *Mechanical Data*.

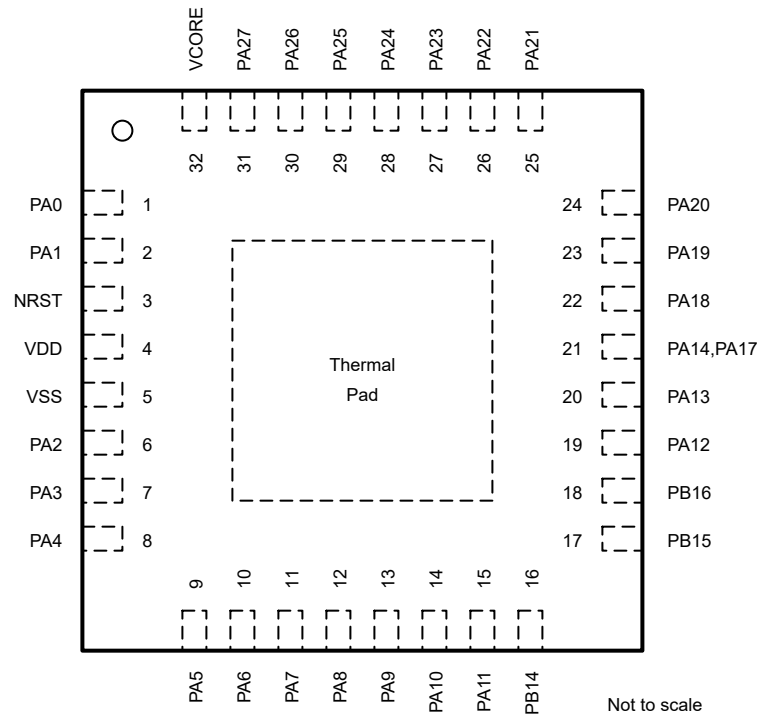




**Figure 6-2. 48-pin RGZ (VQFN) Package**

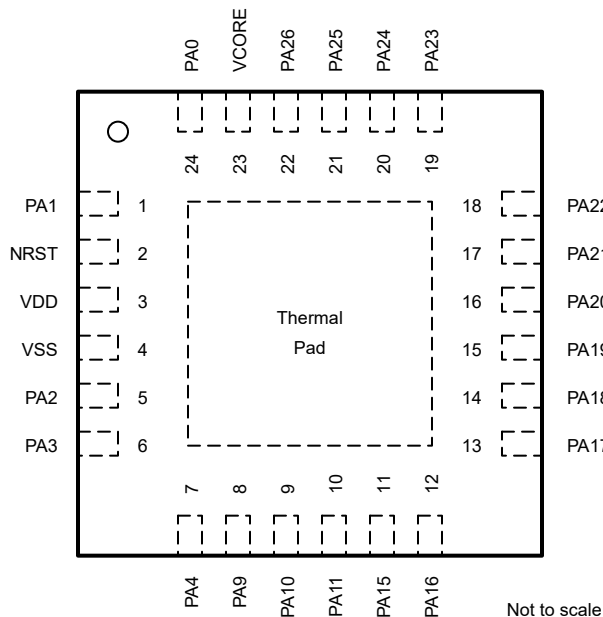


**Figure 6-3. 48-pin PT (LQFP) Package**



**Figure 6-4. 32-pin RHB (VQFN) Package**





**Figure 6-7. 24-pin RGE (VQFN) Package**

## 6.2 Pin Attributes

The following table describes the functions available on every pin for each device package.

### Note

Each digital I/O on a device is mapped to a specific Pin Control Management Register (PINCMx) that lets users configure the desired *Pin Function* using the PINCM.PF control bits.

Each digital I/O on a device is mapped to a specific Pin Control Management Register (PINCMx) which allows users to configure the desired Pin Function using the PINCM.PF control bits. The IOMUX only supports connecting one IOMUX-managed digital function to the pin at the same time. The PINCM.PF and PINCM.PC in *IOMUX* are recommended to be set to 0 when non-IOMUX managed functions (such as analog connections) are intended to be used on a pin. However, non-IOMUX managed signals (such as analog inputs and WAKE inputs) can be enabled on a pin at the same time that an IOMUX managed digital function is enabled on the pin, provided there is no contention between the functions. In this case, the designer must verify that no contention exists between the functions enabled on each pin.

**Table 6-1. Digital IO Features by IO Type**

BUFFER TYPE	INVERSION CONTROL	DRIVE STRENGTH CONTROL	HYSTERESIS CONTROL	PULLUP RESISTOR	PULLDOWN RESISTOR	WAKEUP LOGIC
LDIO (Low drive)	Y			Y	Y	
LDIO (Low drive) with wake	Y			Y	Y	Y
SDIO (standard drive)	Y			Y	Y	
SDIO (standard drive) with wake	Y			Y	Y	Y
HDIO (High drive)	Y			Y	Y	Y
ODIO (5V-tolerant open drain)	Y		Y		Y	Y

**Table 6-2. Pin Attributes (PM, DGS28, PT, RGZ, RGE, RUY, RHB Packages)**

PM PIN	DGS28 PIN	PT PIN	RGZ PIN	RGE PIN	RUY PIN	RHB PIN	PIN NAME/ IOMUX REG/ IOMUX ADDR	SIGNAL NAME	IOMUX PF	SIGNAL TYPE	BUFFER TYPE
38	6	4	4	2	2	3	NRST	NRST	(Non-IOMUX 1) 0	RESET	RESET
33	4	1	1	24	28	1	PA0 PINCM1 0x40428000	PA0	1	IO	ODIO (5V- tol)with wake
								UC4_PICO_TX	2	IO	
								UC6_SDA	3	IOD	
								TIMA0_C0	4	IO	
								TIMA_FAL1	5	I	
								FCC_IN	6	I	
								BEEP	8	O	
								TIMG14_C0	9	IO	
								UC7_SDA	11	IOD	
BSLSDA	(Non-IOMUX 1) 0	IOD									
34	5	2	2	1	1	2	PA1 PINCM2 0x40428004	PA1	1	IO	ODIO (5V- tol)with wake
								UC4_SCLK_RX	2	IOD	
								UC6_SCL	3	IOD	
								TIMA0_C1	4	IO	
								TIMA_FAL2	5	I	
								TIMG14_C3	6	IO	
								TIMG14_C2	7	IO	
								TIMG14_C1	9	IO	
								UC7_SCL	11	IOD	
BSLSCL	(Non-IOMUX 1) 0	IOD									
42	9	8	8	5	5	6	PA2 PINCM7 0x40428018	PA2	1	IO	LDIO
								TIMG14_C3	2	IO	
								UC4_CS0_CTS	3	IO	
								TIMG2_C1	4	IO	
								UC8_CS0	5	IO	
								TIMA0_C3N	6	O	
								TIMA0_C2N	7	O	
								TIMA_FAL0	8	I	
								TIMA_FAL1	9	I	
TIMA0_C0	11	IO									
43	10	9	9	6	6	7	PA3 PINCM8 0x4042801c	PA3	1	IO	SDIO (standard)
								TIMG14_C2	2	IO	
								UC7_SDA	4	IOD	
								TIMA0_C1	5	IO	
								COMP0_OUT	6	O	
								TIMG2_C0	7	IO	
								TIMA0_C2	8	IO	
								UC8_PICO_TX	10	IO	
LFXIN	(Non-IOMUX 1) 0	A									

**Table 6-2. Pin Attributes (PM, DGS28, PT, RGZ, RGE, RUY, RHB Packages) (continued)**

PM PIN	DGS28 PIN	PT PIN	RGZ PIN	RGE PIN	RUY PIN	RHB PIN	PIN NAME/ IOMUX REG/ IOMUX ADDR	SIGNAL NAME	IOMUX PF	SIGNAL TYPE	BUFFER TYPE
44	11	10	10	7	7	8	PA4 PINCM9 0x40428020	PA4	1	IO	SDIO (standard)
								TIMG14_C3	2	IO	
								UC4_POCI_RTS	3	IO	
								UC7_SCL	4	IOD	
								TIMA0_C1N	5	O	
								LFCLKIN	6	I	
								TIMG2_C1	7	IO	
								TIMA0_C3	8	IO	
								UC8_SCLK_RX	10	IOD	
								UC4_CS0_CTS	11	IO	
								LFXOUT	(Non-IOMUX 1) 0	A	
45	12	11	11	8	9	PA5 PINCM10 0x40428024	PA5	1	IO	LDIO	
							TIMG14_C2	2	IO		
							UC4_PICO_TX	3	IO		
							UC7_SDA	4	IOD		
							TIMG14_C0	5	IO		
							FCC_IN	6	I		
							TIMG1_C0	7	IO		
							TIMA_FAL1	8	I		
							UC4_CS0_CTS	9	IO		
							UC8_PICO_TX	11	IO		
							HFXIN	(Non-IOMUX 1) 0	A		
LCD_LCD50	(Non-IOMUX 2) 0	A									
46	13	12	12	9	10	PA6 PINCM11 0x40428028	PA6	1	IO	LDIO	
							TIMG14_C3	2	IO		
							UC4_SCLK_RX	3	IOD		
							UC7_SCL	4	IOD		
							TIMG14_C1	5	IO		
							HFCLKIN	6	I		
							TIMG1_C1	7	IO		
							TIMA_FAL0	8	I		
							UC4_POCI_RTS	9	IO		
							TIMA0_C2N	10	O		
							UC8_SCLK_RX	11	IOD		
HFXOUT	(Non-IOMUX 1) 0	A									
LCD_LCD51	(Non-IOMUX 2) 0	A									
49	13	13	13	11	11	PA7 PINCM14 0x40428034	PA7	1	IO	LDIO	
							COMP0_OUT	2	O		
							CLK_OUT	3	O		
							TIMG14_C2	4	IO		
							TIMA0_C2	5	IO		
							TIMG14_C3	6	IO		
							TIMG2_C1	7	IO		
							TIMA0_C1	8	IO		
							FCC_IN	10	I		
							UC4_POCI_RTS	11	IO		
							LCD_LCD46	(Non-IOMUX 1) 0	A		

**Table 6-2. Pin Attributes (PM, DGS28, PT, RGZ, RGE, RUY, RHB Packages) (continued)**

PM PIN	DGS28 PIN	PT PIN	RGZ PIN	RGE PIN	RUY PIN	RHB PIN	PIN NAME/ IOMUX REG/ IOMUX ADDR	SIGNAL NAME	IOMUX PF	SIGNAL TYPE	BUFFER TYPE
54		16	16			12	PA8 PINCM19 0x40428048	PA8	1	IO	LDIO
								UC8_PICO_TX	2	IO	
								UC4_CS0_CTS	3	IO	
								UC6_SDA	4	IOD	
								TIMA0_C0	5	IO	
								TIMA_FAL2	6	I	
								TIMA_FAL0	7	I	
								TIMG2_C1	9	IO	
								HFCLKIN	10	I	
								UC4_POCI_RTS	11	IO	
								LCD_LCD0	(Non-IOMUX 1) 0	A	
55	14	17	17	8		13	PA9 PINCM20 0x4042804c	PA9	1	IO	LDIO
								UC8_SCLK_RX	2	IOD	
								UC4_PICO_TX	3	IO	
								UC6_SCL	4	IOD	
								TIMA0_C0N	5	O	
								CLK_OUT	6	O	
								TIMA0_C1	7	IO	
								RTC_OUT	8	O	
								TIMG2_C0	9	IO	
								UC4_CS0_CTS	11	IO	
								LCD_LCD1	(Non-IOMUX 1) 0	A	
56	15	18	18	9	10	14	PA10 PINCM21 0x40428050	PA10	1	IO	HDIO (high-drive)with wake
								UC4_PICO_TX	2	IO	
								UC4_POCI_RTS	3	IO	
								UC6_SDA	4	IOD	
								TIMA0_C2	5	IO	
								CLK_OUT	6	O	
								TIMG14_C0	7	IO	
								UC7_SDA	8	IOD	
								TIMA_FAL1	10	I	
								BSLTX	(Non-IOMUX 1) 0	O	
								LCD_LCD2	(Non-IOMUX 2) 0	A	
57	16	19	19	10	11	15	PA11 PINCM22 0x40428054	PA11	1	IO	HDIO (high-drive)with wake
								UC4_SCLK_RX	2	IOD	
								UC6_SCL	4	IOD	
								TIMA0_C2N	5	O	
								COMP0_OUT	6	O	
								TIMG14_C1	7	IO	
								UC7_SCL	8	IOD	
								TIMA_FAL0	10	I	
								BSLRX	(Non-IOMUX 1) 0	I	
								COMP0_DAC_OUT	(Non-IOMUX 2) 0	A	
								LCD_LCD3	(Non-IOMUX 3) 0	A	

**Table 6-2. Pin Attributes (PM, DGS28, PT, RGZ, RGE, RUY, RHB Packages) (continued)**

PM PIN	DGS28 PIN	PT PIN	RGZ PIN	RGE PIN	RUY PIN	RHB PIN	PIN NAME/ IOMUX REG/ IOMUX ADDR	SIGNAL NAME	IOMUX PF	SIGNAL TYPE	BUFFER TYPE
5	19	27	27		15	19	PA12 PINCM34 0x40428084	PA12	1	IO	LDIO
								UC4_POCI_RTS	2	IO	
								UC4_SCLK_RX	3	IOD	
								COMP0_OUT	4	O	
								TIMA0_C3	5	IO	
								FCC_IN	6	I	
								TIMG14_C0	7	IO	
								UC7_SCL	8	IOD	
								TIMA0_C2	9	IO	
								ADC0_18	(Non-IOMUX 1) 0	A	
								LCD_R33	(Non-IOMUX 2) 0	A	
								LCD_LCD11	(Non-IOMUX 3) 0	A	
6	20	28	28		16	20	PA13 PINCM35 0x40428088	PA13	1	IO	LDIO
								TIMA0_C2N	2	O	
								UC4_POCI_RTS	3	IO	
								UC7_SDA	4	IOD	
								TIMA0_C3N	5	O	
								RTC_OUT	6	O	
								TIMG14_C1	7	IO	
								UC8_CS0	8	IO	
								UC8_POCI	9	IO	
								UC11_TX	10	IO	
								COMP0_OUT	11	O	
								ADC0_17	(Non-IOMUX 1) 0	A	
LCD_LCDCAP0	(Non-IOMUX 2) 0	A									
COMP0_IN2-	(Non-IOMUX 3) 0	A									
LCD_LCD12	(Non-IOMUX 4) 0	A									
7	21	29	29		17	21	PA14 PINCM36 0x4042808c	PA14	1	IO	LDIO
								UC4_CS0_CTS	2	IO	
								UC4_PICO_TX	3	IO	
								CLK_OUT	6	O	
								UC11_RX	10	IO	
								ADC0_16	(Non-IOMUX 1) 0	A	
								LCD_LCDCAP1	(Non-IOMUX 2) 0	A	
								COMP0_IN2+	(Non-IOMUX 3) 0	A	
LCD_LCD13	(Non-IOMUX 4) 0	A									
8		30	30	11			PA15 PINCM37 0x40428090	PA15	1	IO	LDIO
								UC4_POCI_RTS	2	IO	
								UC7_SCL	4	IOD	
								TIMA0_C2	5	IO	
								TIMG14_C2	7	IO	
								LCD_LCDEN	9	IO	
								ADC0_15	(Non-IOMUX 1) 0	A	
								COMP0_IN3+	(Non-IOMUX 2) 0	A	
LCD_LCD14	(Non-IOMUX 3) 0	A									

**Table 6-2. Pin Attributes (PM, DGS28, PT, RGZ, RGE, RUY, RHB Packages) (continued)**

PM PIN	DGS28 PIN	PT PIN	RGZ PIN	RGE PIN	RUY PIN	RHB PIN	PIN NAME/ IOMUX REG/ IOMUX ADDR	SIGNAL NAME	IOMUX PF	SIGNAL TYPE	BUFFER TYPE
9		31	31	12			PA16 PINCM38 0x40428094	PA16	1	IO	LDIO
								COMP0_OUT	2	O	
								UC8_POCI	3	IO	
								UC7_SDA	4	IOD	
								TIMA0_C2N	5	O	
								FCC_IN	7	I	
								LCD_LCDSON	9	IO	
								ADC0_14	(Non-IOMUX 1) 0	A	
LCD_LCD15	(Non-IOMUX 2) 0	A									
10		32	32	13		21	PA17 PINCM39 0x40428098	PA17	1	IO	LDIO with wake
								UC8_PICO_TX	2	IO	
								UC8_SCLK_RX	3	IOD	
								UC7_SCL	4	IOD	
								TIMA0_C3	5	IO	
								TIMG2_C0	6	IO	
								TIMG14_C2	7	IO	
								LCD_LCDLFLCK	10	IO	
								ADC0_13	(Non-IOMUX 1) 0	A	
								COMP0_IN1-	(Non-IOMUX 2) 0	A	
LCD_LCD16	(Non-IOMUX 3) 0	A									
11	21	33	33	14	17	22	PA18 PINCM40 0x4042809c	PA18	1	IO	LDIO with wake
								UC8_SCLK_RX	2	IOD	
								UC8_PICO_TX	3	IO	
								UC7_SDA	4	IOD	
								TIMA0_C3N	5	O	
								TIMG2_C1	6	IO	
								TIMG14_C3	7	IO	
								UC4_CS0_CTS	9	IO	
								LCD_LCDEN	10	IO	
								BSL_invoke	(Non-IOMUX 1) 0	I	
								ADC0_12	(Non-IOMUX 2) 0	A	
								COMP0_IN1+	(Non-IOMUX 3) 0	A	
LCD_LCD17	(Non-IOMUX 4) 0	A									
12	22	34	34	15	18	23	PA19 PINCM41 0x404280a0	PA19	1	IO	LDIO
								SWDIO	2	IO	
								UC8_POCI	3	IO	
								UC7_SDA	4	IOD	
								TIMA0_C2	5	IO	
								TIMG14_C0	6	IO	
								LCD_LCD49	(Non-IOMUX 1) 0	A	
13	23	35	35	16	19	24	PA20 PINCM42 0x404280a4	PA20	1	IO	SDIO (standard)
								SWCLK	2	I	
								UC8_SCLK_RX	3	IOD	
								UC7_SCL	4	IOD	
								TIMA0_C2N	5	O	
								TIMG14_C1	6	IO	

**Table 6-2. Pin Attributes (PM, DGS28, PT, RGZ, RGE, RUY, RHB Packages) (continued)**

PM PIN	DGS28 PIN	PT PIN	RGZ PIN	RGE PIN	RUY PIN	RHB PIN	PIN NAME/ IOMUX REG/ IOMUX ADDR	SIGNAL NAME	IOMUX PF	SIGNAL TYPE	BUFFER TYPE
17	24	39	39	17	20	25	PA21 PINCM46 0x404280b4	PA21	1	IO	LDIO
								UC11_TX	2	IO	
								TIMA0_C0	5	IO	
								TIMG1_C0	6	IO	
								TIMG14_C2	10	IO	
								ADC0_8	(Non-IOMUX 1) 0	A	
								ADC0_VREF-	(Non-IOMUX 2) 0	A	
LCD_LCD21	(Non-IOMUX 3) 0	A									
18	25	40	40	18	21	26	PA22 PINCM47 0x404280b8	PA22	1	IO	LDIO
								UC11_RX	2	IO	
								TIMA0_C0N	5	O	
								TIMG1_C1	6	IO	
								TIMA0_C1	7	IO	
								CLK_OUT	8	O	
								UC6_SCL	9	IOD	
								TIMG14_C3	10	IO	
								ADC0_7	(Non-IOMUX 1) 0	A	
LCD_LCD22	(Non-IOMUX 2) 0	A									
24	26	43	43	19	23	27	PA23 PINCM53 0x404280d0	PA23	1	IO	LDIO
								UC11_TX	2	IO	
								TIMA0_C3	5	IO	
								TIMG14_C2	6	IO	
								TIMG2_C0	7	IO	
								TIMG14_C0	9	IO	
								ADC0_VREF+	(Non-IOMUX 1) 0	A	
LCD_LCD25	(Non-IOMUX 2) 0	A									
25	27	44	44	20	24	28	PA24 PINCM54 0x404280d4	PA24	1	IO	LDIO
								UC11_RX	2	IO	
								TIMA0_C3N	5	O	
								TIMG14_C3	6	IO	
								TIMG2_C1	7	IO	
								TIMG14_C1	9	IO	
								ADC0_3	(Non-IOMUX 1) 0	A	
LCD_LCD26	(Non-IOMUX 2) 0	A									
26	28	45	45	21		29	PA25 PINCM55 0x404280d8	PA25	1	IO	LDIO
								TIMA0_C3	5	IO	
								TIMA0_C1N	6	O	
								COMP0_OUT	7	O	
								TIMG1_C0	10	IO	
								ADC0_2	(Non-IOMUX 1) 0	A	
LCD_LCD27	(Non-IOMUX 2) 0	A									

**Table 6-2. Pin Attributes (PM, DGS28, PT, RGZ, RGE, RUY, RHB Packages) (continued)**

PM PIN	DGS28 PIN	PT PIN	RGZ PIN	RGE PIN	RUY PIN	RHB PIN	PIN NAME/ IOMUX REG/ IOMUX ADDR	SIGNAL NAME	IOMUX PF	SIGNAL TYPE	BUFFER TYPE
30	1	46	46	22	25	30	PA26 PINCM59 0x404280e8	PA26	1	IO	LDIO
								UC8_CS0	3	IO	
								TIMG14_C2	4	IO	
								TIMA_FAL0	5	I	
								TIMA0_C3N	6	O	
								TIMG2_C0	7	IO	
								TIMG1_C1	10	IO	
								ADC0_1	(Non-IOMUX 1) 0	A	
								COMP0_IN0+	(Non-IOMUX 2) 0	A	
LCD_LCD28	(Non-IOMUX 3) 0	A									
31	2	47	47	26	31	PA27 PINCM60 0x404280ec	PA27	1	IO	LDIO	
							TIMG14_C3	4	IO		
							TIMA_FAL2	5	I		
							CLK_OUT	6	O		
							TIMG2_C1	7	IO		
							RTC_OUT	8	O		
							COMP0_OUT	9	O		
							ADC0_0	(Non-IOMUX 1) 0	A		
							COMP0_IN0-	(Non-IOMUX 2) 0	A		
LCD_LCD29	(Non-IOMUX 3) 0	A									
35	3	3	3	28	35	PA28 PINCM3 0x40428008	PA28	1	IO	HDIO (high-drive)with wake	
							UC4_PICO_TX	2	IO		
							UC6_SDA	3	IOD		
							TIMA0_C3	4	IO		
							TIMA_FAL0	5	I		
							TIMG2_C0	6	IO		
							TIMA0_C1	7	IO		
LCD_LCD30	(Non-IOMUX 1) 0	A									
36	4	4	4	29	36	PA29 PINCM4 0x4042800c	PA29	1	IO	LDIO	
							UC7_SCL	2	IOD		
							TIMG14_C2	4	IO		
							TIMG1_C0	5	IO		
							UC4_CS0_CTS	7	IO		
LCD_LCD31	(Non-IOMUX 1) 0	A									
37	5	5	5	30	37	PA30 PINCM5 0x40428010	PA30	1	IO	LDIO	
							UC7_SDA	2	IOD		
							TIMG14_C3	4	IO		
							TIMG1_C1	5	IO		
							UC4_POCI_RTS	7	IO		
LCD_LCD32	(Non-IOMUX 1) 0	A									
39	6	6	6	31	39	PA31 PINCM6 0x40428014	PA31	1	IO	LDIO	
							UC4_SCLK_RX	2	IOD		
							UC6_SCL	3	IOD		
							TIMA0_C3N	4	O		
							CLK_OUT	6	O		
							TIMG2_C1	7	IO		
LCD_LCD45	(Non-IOMUX 1) 0	A									

**Table 6-2. Pin Attributes (PM, DGS28, PT, RGZ, RGE, RUY, RHB Packages) (continued)**

PM PIN	DGS28 PIN	PT PIN	RGZ PIN	RGE PIN	RUY PIN	RHB PIN	PIN NAME/ IOMUX REG/ IOMUX ADDR	SIGNAL NAME	IOMUX PF	SIGNAL TYPE	BUFFER TYPE
47							PB0 PINCM12 0x4042802c	PB0	1	IO	SDIO (standard)
								UC4_PICO_TX	2	IO	
								UC6_SCL	4	IOD	
								TIMA0_C2	5	IO	
								TIMG14_C0	6	IO	
48							PB1 PINCM13 0x40428030	PB1	1	IO	SDIO (standard)
								UC4_SCLK_RX	2	IOD	
								UC6_SDA	4	IOD	
								TIMA0_C2N	5	O	
								TIMG14_C1	6	IO	
50		14	14				PB2 PINCM15 0x40428038	PB2	1	IO	LDIO
								UC7_SCL	4	IOD	
								TIMA0_C3	5	IO	
								TIMG1_C0	7	IO	
								UC11_TX	8	IO	
								HFCLKIN	10	I	
								UC4_PICO_TX	11	IO	
								LCD_LCD47	(Non-IOMUX 1) 0	A	
51		15	15				PB3 PINCM16 0x4042803c	PB3	1	IO	LDIO
								UC7_SDA	4	IOD	
								TIMA0_C3N	5	O	
								TIMG1_C1	7	IO	
								UC11_RX	8	IO	
								TIMA0_C0	10	IO	
								UC4_SCLK_RX	11	IOD	
								LCD_LCD48	(Non-IOMUX 1) 0	A	
52							PB4 PINCM17 0x40428040	PB4	1	IO	LDIO
								UC8_PICO_TX	2	IO	
								TIMA0_C1	4	IO	
								TIMA0_C2	5	IO	
								TIMG14_C0	6	IO	
								TIMG1_C0	7	IO	
								LCD_LCD33	(Non-IOMUX 1) 0	A	
53							PB5 PINCM18 0x40428044	PB5	1	IO	LDIO
								UC8_SCLK_RX	2	IOD	
								TIMA0_C1N	4	O	
								TIMA0_C2N	5	O	
								TIMG14_C1	6	IO	
								TIMG1_C1	7	IO	
								LCD_LCD34	(Non-IOMUX 1) 0	A	
58		20	20				PB6 PINCM23 0x40428058	PB6	1	IO	LDIO
								UC8_PICO_TX	2	IO	
								UC8_CS0	3	IO	
								TIMG14_C2	5	IO	
								TIMG1_C0	7	IO	
								TIMA_FAL2	8	I	
								LCD_LCD4	(Non-IOMUX 1) 0	A	

**Table 6-2. Pin Attributes (PM, DGS28, PT, RGZ, RGE, RUY, RHB Packages) (continued)**

PM PIN	DGS28 PIN	PT PIN	RGZ PIN	RGE PIN	RUY PIN	RHB PIN	PIN NAME/ IOMUX REG/ IOMUX ADDR	SIGNAL NAME	IOMUX PF	SIGNAL TYPE	BUFFER TYPE
59		21	21				PB7 PINCM24 0x4042805c	PB7	1	IO	LDIO
								UC8_SCLK_RX	2	IOD	
								UC8_POCI	3	IO	
								TIMG14_C3	5	IO	
								TIMG1_C1	7	IO	
								LCD_LCDFCLK	8	IO	
LCD_LCD5	(Non-IOMUX 1) 0	A									
60		22	22				PB8 PINCM25 0x40428060	PB8	1	IO	LDIO
								UC8_PICO_TX	3	IO	
								TIMA0_C0	5	IO	
								COMP0_OUT	6	O	
								TIMG1_C0	7	IO	
								LCD_LCDSON	8	IO	
LCD_LCD6	(Non-IOMUX 1) 0	A									
61		23	23				PB9 PINCM26 0x40428064	PB9	1	IO	LDIO
								UC8_SCLK_RX	3	IOD	
								TIMA0_C0N	5	O	
								TIMA0_C1	6	IO	
								TIMG1_C1	7	IO	
								LCD_LCDEN	8	IO	
LCD_LCD7	(Non-IOMUX 1) 0	A									
62							PB10 PINCM27 0x40428068	PB10	1	IO	LDIO
								TIMG14_C0	2	IO	
								TIMG14_C2	3	IO	
								COMP0_OUT	4	O	
								TIMG1_C0	5	IO	
								LCD_LCD35	(Non-IOMUX 1) 0	A	
63							PB11 PINCM28 0x4042806c	PB11	1	IO	LDIO
								TIMG14_C1	2	IO	
								TIMG14_C3	3	IO	
								CLK_OUT	4	O	
								TIMG1_C1	5	IO	
								LCD_LCD36	(Non-IOMUX 1) 0	A	
64							PB12 PINCM29 0x40428070	PB12	1	IO	LDIO
								TIMA0_C2	3	IO	
								TIMA_FAL1	4	I	
								TIMA0_C1	5	IO	
								LCD_LCD37	(Non-IOMUX 1) 0	A	
1							PB13 PINCM30 0x40428074	PB13	1	IO	LDIO
								TIMA0_C3	3	IO	
								TIMA0_C1N	5	O	
								UC8_CS0	7	IO	
								LCD_LCD38	(Non-IOMUX 1) 0	A	

**Table 6-2. Pin Attributes (PM, DGS28, PT, RGZ, RGE, RUY, RHB Packages) (continued)**

PM PIN	DGS28 PIN	PT PIN	RGZ PIN	RGE PIN	RUY PIN	RHB PIN	PIN NAME/ IOMUX REG/ IOMUX ADDR	SIGNAL NAME	IOMUX PF	SIGNAL TYPE	BUFFER TYPE
2	16	24	24		12	16	PB14 PINCM31 0x40428078	PB14	1	IO	LDIO
								UC8_SCLK_RX	2	IOD	
								UC8_POCI	3	IO	
								FCC_IN	4	I	
								TIMA0_C0	5	IO	
								TIMG14_C2	6	IO	
								TIMG14_C0	7	IO	
								COMP0_OUT	10	O	
								ADC0_21	(Non-IOMUX 1) 0	A	
								LCD_R13	(Non-IOMUX 2) 0	A	
LCD_LCD8	(Non-IOMUX 3) 0	A									
3	17	25	25		13	17	PB15 PINCM32 0x4042807c	PB15	1	IO	LDIO
								UC11_TX	2	IO	
								UC8_PICO_TX	3	IO	
								UC4_POCI_RTS	4	IO	
								TIMG14_C2	5	IO	
								TIMG2_C0	6	IO	
								TIMA0_C3N	7	O	
								RTC_OUT	8	O	
								TIMG14_C1	9	IO	
								UC8_CS0	10	IO	
ADC0_20	(Non-IOMUX 1) 0	A									
LCD_R24	(Non-IOMUX 2) 0	A									
LCD_LCD9	(Non-IOMUX 3) 0	A									
4	18	26	26		14	18	PB16 PINCM33 0x40428080	PB16	1	IO	LDIO
								UC11_RX	2	IO	
								UC8_SCLK_RX	3	IOD	
								UC4_CS0_CTS	4	IO	
								TIMG14_C3	5	IO	
								TIMG2_C1	6	IO	
								UC4_PICO_TX	7	IO	
								CLK_OUT	8	O	
								ADC0_19	(Non-IOMUX 1) 0	A	
								LCD_R23	(Non-IOMUX 2) 0	A	
LCD_LCD10	(Non-IOMUX 3) 0	A									
14		36	36				PB17 PINCM43 0x404280a8	PB17	1	IO	LDIO
								UC11_TX	2	IO	
								UC4_PICO_TX	3	IO	
								UC6_SCL	4	IOD	
								TIMA0_C2	5	IO	
								TIMG14_C0	6	IO	
								TIMG1_C0	9	IO	
								LCD_LCDSON	10	IO	
								ADC0_11	(Non-IOMUX 1) 0	A	
								LCD_LCD18	(Non-IOMUX 2) 0	A	

**Table 6-2. Pin Attributes (PM, DGS28, PT, RGZ, RGE, RUY, RHB Packages) (continued)**

PM PIN	DGS28 PIN	PT PIN	RGZ PIN	RGE PIN	RUY PIN	RHB PIN	PIN NAME/ IOMUX REG/ IOMUX ADDR	SIGNAL NAME	IOMUX PF	SIGNAL TYPE	BUFFER TYPE
15		37	37				PB18 PINCM44 0x404280ac	PB18	1	IO	LDIO
								UC11_RX	2	IO	
								UC4_SCLK_RX	3	IOD	
								UC6_SDA	4	IOD	
								TIMA0_C2N	5	O	
								TIMG14_C1	6	IO	
								TIMG1_C1	9	IO	
								LCD_LCDLFCLK	10	IO	
								ADC0_10	(Non-IOMUX 1) 0	A	
LCD_LCD19	(Non-IOMUX 2) 0	A									
16		38	38				PB19 PINCM45 0x404280b0	PB19	1	IO	LDIO
								COMP0_OUT	2	O	
								UC4_POCI_RTS	3	IO	
								UC4_CS0_CTS	5	IO	
								TIMG2_C1	6	IO	
								TIMG14_C2	7	IO	
								ADC0_9	(Non-IOMUX 1) 0	A	
LCD_LCD20	(Non-IOMUX 2) 0	A									
19		41	41				PB20 PINCM48 0x404280bc	PB20	1	IO	LDIO
								UC8_CS0	3	IO	
								TIMA0_C2	5	IO	
								TIMA_FAL1	6	I	
								TIMA0_C1	7	IO	
								UC6_SDA	9	IOD	
								ADC0_6	(Non-IOMUX 1) 0	A	
LCD_LCD23	(Non-IOMUX 2) 0	A									
20							PB21 PINCM49 0x404280c0	PB21	1	IO	LDIO
								UC8_POCI	3	IO	
								UC6_SCL	4	IOD	
								TIMG14_C2	5	IO	
								UC8_PICO_TX	6	IO	
								ADC0_25	(Non-IOMUX 1) 0	A	
LCD_LCD39	(Non-IOMUX 2) 0	A									
21							PB22 PINCM50 0x404280c4	PB22	1	IO	LDIO
								UC8_PICO_TX	3	IO	
								UC6_SDA	4	IOD	
								TIMG14_C3	5	IO	
								UC8_SCLK_RX	6	IOD	
								ADC0_24	(Non-IOMUX 1) 0	A	
LCD_LCD40	(Non-IOMUX 2) 0	A									
22							PB23 PINCM51 0x404280c8	PB23	1	IO	LDIO
								UC8_SCLK_RX	3	IOD	
								TIMA_FAL0	4	I	
								COMP0_OUT	5	O	
								LCD_LCD41	(Non-IOMUX 1) 0	A	

**Table 6-2. Pin Attributes (PM, DGS28, PT, RGZ, RGE, RUY, RHB Packages) (continued)**

PM PIN	DGS28 PIN	PT PIN	RGZ PIN	RGE PIN	RUY PIN	RHB PIN	PIN NAME/ IOMUX REG/ IOMUX ADDR	SIGNAL NAME	IOMUX PF	SIGNAL TYPE	BUFFER TYPE
23		42	42		22		PB24 PINCM52 0x404280cc	PB24	1	IO	LDIO
								TIMA0_C3	5	IO	
								TIMA0_C1N	6	O	
								ADC0_5	(Non-IOMUX 1) 0	A	
								LCD_LCD24	(Non-IOMUX 2) 0	A	
27						PB25 PINCM56 0x404280dc	PB25	1	IO	LDIO	
							UC4_CS0_CTS	2	IO		
							TIMA_FAL0	4	I		
							TIMA_FAL1	5	I		
							TIMA_FAL2	6	I		
							COMP0_OUT	7	O		
							FCC_IN	8	I		
							ADC0_4	(Non-IOMUX 1) 0	A		
LCD_LCD42	(Non-IOMUX 2) 0	A									
28						PB26 PINCM57 0x404280e0	PB26	1	IO	LDIO	
							UC4_POCI_RTS	2	IO		
							TIMA0_C0	4	IO		
							TIMA0_C3	5	IO		
							TIMG1_C0	6	IO		
							COMP0_OUT	7	O		
							FCC_IN	8	I		
							ADC0_23	(Non-IOMUX 1) 0	A		
LCD_LCD43	(Non-IOMUX 2) 0	A									
29						PB27 PINCM58 0x404280e4	PB27	1	IO	LDIO	
							COMP0_OUT	2	O		
							TIMA0_C0N	4	O		
							TIMA0_C3N	5	O		
							TIMG1_C1	6	IO		
							ADC0_22	(Non-IOMUX 1) 0	A		
							LCD_LCD44	(Non-IOMUX 2) 0	A		
32	3	48	48	23	27	32	VCORE	(Non-IOMUX 1) 0	PWR	PWR	
40	7	6	6	3	3	4	VDD	(Non-IOMUX 1) 0	PWR	PWR	
41	8	7	7	4	4	5	VSS	(Non-IOMUX 1) 0	PWR	PWR	

### 6.3 Signal Descriptions

**Table 6-3. Analog to Digital Converter (ADC) Signal Descriptions**

SIGNAL NAME	PIN TYPE	DESCRIPTION	PM PIN	DGS28 PIN	PT PIN	RGZ PIN	RGE PIN	RUY PIN	RHB PIN
ADC0_VREF+	A	ADC0 voltage reference (VREF) power supply	24	26	43	43	19	23	27
ADC0_VREF-	A	ADC0 voltage reference (VREF) ground supply	17	24	39	39	17	20	25
ADC0_0	A	ADC0 analog input channel 0	31	2	47	47		26	31
ADC0_1	A	ADC0 analog input channel 1	30	1	46	46	22	25	30
ADC0_2	A	ADC0 analog input channel 2	26	28	45	45	21		29
ADC0_3	A	ADC0 analog input channel 3	25	27	44	44	20	24	28
ADC0_4	A	ADC0 analog input channel 4	27						

**Table 6-3. Analog to Digital Converter (ADC) Signal Descriptions (continued)**

SIGNAL NAME	PIN TYPE	DESCRIPTION	PM PIN	DGS28 PIN	PT PIN	RGZ PIN	RGE PIN	RUY PIN	RHB PIN
ADC0_5	A	ADC0 analog input channel 5	23		42	42		22	
ADC0_6	A	ADC0 analog input channel 6	19		41	41			
ADC0_7	A	ADC0 analog input channel 7	18	25	40	40	18	21	26
ADC0_8	A	ADC0 analog input channel 8	17	24	39	39	17	20	25
ADC0_9	A	ADC0 analog input channel 9	16		38	38			
ADC0_10	A	ADC0 analog input channel 10	15		37	37			
ADC0_11	A	ADC0 analog input channel 11	14		36	36			
ADC0_12	A	ADC0 analog input channel 12	11	21	33	33	14	17	22
ADC0_13	A	ADC0 analog input channel 13	10		32	32	13		21
ADC0_14	A	ADC0 analog input channel 14	9		31	31	12		
ADC0_15	A	ADC0 analog input channel 15	8		30	30	11		
ADC0_16	A	ADC0 analog input channel 16	7	21	29	29		17	21
ADC0_17	A	ADC0 analog input channel 17	6	20	28	28		16	20
ADC0_18	A	ADC0 analog input channel 18	5	19	27	27		15	19
ADC0_19	A	ADC0 analog input channel 19	4	18	26	26		14	18
ADC0_20	A	ADC0 analog input channel 20	3	17	25	25		13	17
ADC0_21	A	ADC0 analog input channel 21	2	16	24	24		12	16
ADC0_22	A	ADC0 analog input channel 22	29						
ADC0_23	A	ADC0 analog input channel 23	28						
ADC0_24	A	ADC0 analog input channel 24	21						
ADC0_25	A	ADC0 analog input channel 25	20						

**Table 6-4. Flash Bootstrap Loader (BSL) Signal Descriptions**

SIGNAL NAME	PIN TYPE	DESCRIPTION	PM PIN	DGS28 PIN	PT PIN	RGZ PIN	RGE PIN	RUY PIN	RHB PIN
BSLRX	I	BSL UART receive signal (RXD)	57	16	19	19	10	11	15
BSLSCL	IOD	BSL I2C clock signal (SCL)	34	5	2	2	1	1	2
BSLSDA	IOD	BSL I2C data signal (SDA)	33	4	1	1	24	28	56
BSLTX	O	BSL UART transmit signal (TXD)	56	15	18	18	9	10	14
BSL_invoke	I	BSL invoke signal (if BSL is enabled, must be HIGH during BOOTRST for a BSL entry, and LOW during BOOTRST to prevent BSL entry)	11	21	33	33	14	17	22

**Table 6-5. Comparator (COMP) Signal Descriptions**

SIGNAL NAME	PIN TYPE	DESCRIPTION	PM PIN	DGS28 PIN	PT PIN	RGZ PIN	RGE PIN	RUY PIN	RHB PIN
COMP0_DAC_OUT	A	COMP0 DAC output	57	16	19	19	10	11	15
COMP0_OUT	O	COMP0 output	16, 2, 22, 26, 27, 28, 29, 31, 43, 49, 5, 57, 6, 60, 62, 9	10, 16, 19, 2, 20, 28	13, 19, 22, 24, 27, 28, 31, 38, 45, 47, 9	13, 19, 22, 24, 27, 28, 31, 38, 45, 47, 9	10, 12, 21, 6	11, 12, 15, 16, 26, 6	11, 15, 16, 19, 20, 29, 31, 7
COMP0_IN0+	A	COMP0 non-inverting input 0	30	1	46	46	22	25	30
COMP0_IN0-	A	COMP0 inverting input 0	31	2	47	47		26	31

**Table 6-5. Comparator (COMP) Signal Descriptions (continued)**

SIGNAL NAME	PIN TYPE	DESCRIPTION	PM PIN	DGS28 PIN	PT PIN	RGZ PIN	RGE PIN	RUY PIN	RHB PIN
COMP0_IN1+	A	COMP0 non-inverting input 1	11	21	33	33	14	17	22
COMP0_IN1-	A	COMP0 inverting input 1	10		32	32	13		21
COMP0_IN2+	A	COMP0 non-inverting input 2	7	21	29	29		17	21
COMP0_IN2-	A	COMP0 inverting input 2	6	20	28	28		16	20
COMP0_IN3+	A	COMP0 non-inverting input 3	8		30	30	11		

**Table 6-6. General Purpose Input Output Module Signal Descriptions**

SIGNAL NAME	PIN TYPE	DESCRIPTION	PM PIN	DGS28 PIN	PT PIN	RGZ PIN	RGE PIN	RUY PIN	RHB PIN
PA0	IO	GPIO port A input/output 0	33	4	1	1	24	28	1
PA1	IO	GPIO port A input/output 1	34	5	2	2	1	1	2
PA2	IO	GPIO port A input/output 2	42	9	8	8	5	5	6
PA3	IO	GPIO port A input/output 3	43	10	9	9	6	6	7
PA4	IO	GPIO port A input/output 4	44	11	10	10	7	7	8
PA5	IO	GPIO port A input/output 5	45	12	11	11		8	9
PA6	IO	GPIO port A input/output 6	46	13	12	12		9	10
PA7	IO	GPIO port A input/output 7	49		13	13			11
PA8	IO	GPIO port A input/output 8	54		16	16			12
PA9	IO	GPIO port A input/output 9	55	14	17	17	8		13
PA10	IO	GPIO port A input/output 10	56	15	18	18	9	10	14
PA11	IO	GPIO port A input/output 11	57	16	19	19	10	11	15
PA12	IO	GPIO port A input/output 12	5	19	27	27		15	19
PA13	IO	GPIO port A input/output 13	6	20	28	28		16	20
PA14	IO	GPIO port A input/output 14	7	21	29	29		17	21
PA15	IO	GPIO port A input/output 15	8		30	30	11		
PA16	IO	GPIO port A input/output 16	9		31	31	12		
PA17	IO	GPIO port A input/output 17	10		32	32	13		21
PA18	IO	GPIO port A input/output 18	11	21	33	33	14	17	22
PA19	IO	GPIO port A input/output 19	12	22	34	34	15	18	23
PA20	IO	GPIO port A input/output 20	13	23	35	35	16	19	24
PA21	IO	GPIO port A input/output 21	17	24	39	39	17	20	25
PA22	IO	GPIO port A input/output 22	18	25	40	40	18	21	26
PA23	IO	GPIO port A input/output 23	24	26	43	43	19	23	27
PA24	IO	GPIO port A input/output 24	25	27	44	44	20	24	28
PA25	IO	GPIO port A input/output 25	26	28	45	45	21		29
PA26	IO	GPIO port A input/output 26	30	1	46	46	22	25	30
PA27	IO	GPIO port A input/output 27	31	2	47	47		26	31
PA28	IO	GPIO port A input/output 28	35		3	3			
PA29	IO	GPIO port A input/output 29	36						
PA30	IO	GPIO port A input/output 30	37						
PA31	IO	GPIO port A input/output 31	39		5	5			
PB0	IO	GPIO port B input/output 0	47						
PB1	IO	GPIO port B input/output 1	48						
PB2	IO	GPIO port B input/output 2	50		14	14			
PB3	IO	GPIO port B input/output 3	51		15	15			

**Table 6-6. General Purpose Input Output Module Signal Descriptions (continued)**

SIGNAL NAME	PIN TYPE	DESCRIPTION	PM PIN	DGS28 PIN	PT PIN	RGZ PIN	RGE PIN	RUY PIN	RHB PIN
PB4	IO	GPIO port B input/output 4	52						
PB5	IO	GPIO port B input/output 5	53						
PB6	IO	GPIO port B input/output 6	58		20	20			
PB7	IO	GPIO port B input/output 7	59		21	21			
PB8	IO	GPIO port B input/output 8	60		22	22			
PB9	IO	GPIO port B input/output 9	61		23	23			
PB10	IO	GPIO port B input/output 10	62						
PB11	IO	GPIO port B input/output 11	63						
PB12	IO	GPIO port B input/output 12	64						
PB13	IO	GPIO port B input/output 13	1						
PB14	IO	GPIO port B input/output 14	2	16	24	24		12	16
PB15	IO	GPIO port B input/output 15	3	17	25	25		13	17
PB16	IO	GPIO port B input/output 16	4	18	26	26		14	18
PB17	IO	GPIO port B input/output 17	14		36	36			
PB18	IO	GPIO port B input/output 18	15		37	37			
PB19	IO	GPIO port B input/output 19	16		38	38			
PB20	IO	GPIO port B input/output 20	19		41	41			
PB21	IO	GPIO port B input/output 21	20						
PB22	IO	GPIO port B input/output 22	21						
PB23	IO	GPIO port B input/output 23	22						
PB24	IO	GPIO port B input/output 24	23		42	42		22	
PB25	IO	GPIO port B input/output 25	27						
PB26	IO	GPIO port B input/output 26	28						
PB27	IO	GPIO port B input/output 27	29						

**Table 6-7. Liquid Crystal Display (LCD) Signal Descriptions**

SIGNAL NAME	PIN TYPE	DESCRIPTION	PM PIN	DGS28 PIN	PT PIN	RGZ PIN	RGE PIN	RUY PIN	RHB PIN
LCD_LCD0	A	LCD segment 0	54		16	16			12
LCD_LCD1	A	LCD segment 1	55	14	17	17	8		13
LCD_LCD2	A	LCD segment 2	56	15	18	18	9	10	14
LCD_LCD3	A	LCD segment 3	57	16	19	19	10	11	15
LCD_LCD4	A	LCD segment 4	58		20	20			
LCD_LCD5	A	LCD segment 5	59		21	21			
LCD_LCD6	A	LCD segment 6	60		22	22			
LCD_LCD7	A	LCD segment 7	61		23	23			
LCD_LCD8	A	LCD segment 8	2	16	24	24		12	16
LCD_LCD9	A	LCD segment 9	3	17	25	25		13	17
LCD_LCD10	A	LCD segment 10	4	18	26	26		14	18
LCD_LCD11	A	LCD segment 11	5	19	27	27		15	19
LCD_LCD12	A	LCD segment 12	6	20	28	28		16	20
LCD_LCD13	A	LCD segment 13	7	21	29	29		17	21
LCD_LCD14	A	LCD segment 14	8		30	30	11		
LCD_LCD15	A	LCD segment 15	9		31	31	12		
LCD_LCD16	A	LCD segment 16	10		32	32	13		21

Table 6-7. Liquid Crystal Display (LCD) Signal Descriptions (continued)

SIGNAL NAME	PIN TYPE	DESCRIPTION	PM PIN	DGS28 PIN	PT PIN	RGZ PIN	RGE PIN	RUY PIN	RHB PIN
LCD_LCD17	A	LCD segment 17	11	21	33	33	14	17	22
LCD_LCD18	A	LCD segment 18	14		36	36			
LCD_LCD19	A	LCD segment 19	15		37	37			
LCD_LCD20	A	LCD segment 20	16		38	38			
LCD_LCD21	A	LCD segment 21	17	24	39	39	17	20	25
LCD_LCD22	A	LCD segment 22	18	25	40	40	18	21	26
LCD_LCD23	A	LCD segment 23	19		41	41			
LCD_LCD24	A	LCD segment 24	23		42	42		22	
LCD_LCD25	A	LCD segment 25	24	26	43	43	19	23	27
LCD_LCD26	A	LCD segment 26	25	27	44	44	20	24	28
LCD_LCD27	A	LCD segment 27	26	28	45	45	21		29
LCD_LCD28	A	LCD segment 28	30	1	46	46	22	25	30
LCD_LCD29	A	LCD segment 29	31	2	47	47		26	31
LCD_LCD30	A	LCD segment 30	35		3	3			
LCD_LCD31	A	LCD segment 31	36						
LCD_LCD32	A	LCD segment 32	37						
LCD_LCD33	A	LCD segment 33	52						
LCD_LCD34	A	LCD segment 34	53						
LCD_LCD35	A	LCD segment 35	62						
LCD_LCD36	A	LCD segment 36	63						
LCD_LCD37	A	LCD segment 37	64						
LCD_LCD38	A	LCD segment 38	1						
LCD_LCD39	A	LCD segment 39	20						
LCD_LCD40	A	LCD segment 40	21						
LCD_LCD41	A	LCD segment 41	22						
LCD_LCD42	A	LCD segment 42	27						
LCD_LCD43	A	LCD segment 43	28						
LCD_LCD44	A	LCD segment 44	29						
LCD_LCD45	A	LCD segment 45	39		5	5			
LCD_LCD46	A	LCD segment 46	49		13	13			11
LCD_LCD47	A	LCD segment 47	50		14	14			
LCD_LCD48	A	LCD segment 48	51		15	15			
LCD_LCD49	A	LCD segment 49	12	22	34	34	15	18	23
LCD_LCD50	A	LCD segment 50	45	12	11	11		8	9
LCD_LCD51	A	LCD segment 51	46	13	12	12		9	10
LCD_LCDCAP0	A	LCD capacitor pin 0	6	20	28	28		16	20
LCD_LCDCAP1	A	LCD capacitor pin 1	7	21	29	29		17	21
LCD_LCDEN	IO	LCD enable signal	11, 61, 8	21	23, 30, 33	23, 30, 33	11, 14	17	22
LCD_LCDLFCLK	IO	LCD ?LFCLK signal	10, 15, 59		21, 32, 37	21, 32, 37	13		21
LCD_LCDSON	IO	LCD SON signal	14, 60, 9		22, 31, 36	22, 31, 36	12		
LCD_R13	A	LCD R13 signal	2	16	24	24		12	16
LCD_R23	A	LCD R23 signal	4	18	26	26		14	18

**Table 6-7. Liquid Crystal Display (LCD) Signal Descriptions (continued)**

SIGNAL NAME	PIN TYPE	DESCRIPTION	PM PIN	DGS28 PIN	PT PIN	RGZ PIN	RGE PIN	RUY PIN	RHB PIN
LCD_R24	A	LCD R24 signal	3	17	25	25		13	17
LCD_R33	A	LCD R33 signal	5	19	27	27		15	19

**Table 6-8. Unified Communication Module (UniComm) Signal Descriptions**

SIGNAL NAME	PIN TYPE	DESCRIPTION	PM PIN	DGS28 PIN	PT PIN	RGZ PIN	RGE PIN	RUY PIN	RHB PIN
UC4_PICO_TX	IO	Unified Communication Module UC4: SPI PICO or UART TX signal	14, 33, 35, 4, 45, 47, 50, 55, 56, 7	12, 14, 15, 18, 21, 4	1, 11, 14, 17, 18, 26, 29, 3, 36	1, 11, 14, 17, 18, 26, 29, 3, 36	24, 8, 9	10, 14, 17, 28, 8	1, 13, 14, 18, 21, 9
UC4_POCI_RTS	IO	Unified Communication Module UC4: SPI POCI or UART RTS signal	16, 28, 3, 37, 44, 46, 49, 5, 54, 56, 6, 8	11, 13, 15, 17, 19, 20	10, 12, 13, 16, 18, 25, 27, 28, 30, 38	10, 12, 13, 16, 18, 25, 27, 28, 30, 38	11, 7, 9	10, 13, 15, 16, 7, 9	10, 11, 12, 14, 17, 19, 20, 8
UC4_SCLK_RX	IOD	Unified Communication Module UC4: SPI SCLK or UART RX signal	15, 34, 39, 46, 48, 5, 51, 57	13, 16, 19, 5	12, 15, 19, 2, 27, 37, 5	12, 15, 19, 2, 27, 37, 5	1, 10	1, 11, 15, 9	10, 15, 19, 2
UC6_SCL	IOD	Unified Communication Module UC6: I2C SCL signal	14, 18, 20, 34, 39, 47, 55, 57	14, 16, 25, 5	17, 19, 2, 36, 40, 5	17, 19, 2, 36, 40, 5	1, 10, 18, 8	1, 11, 21	13, 15, 2, 26
UC6_SDA	IOD	Unified Communication Module UC6: I2C SDA signal	15, 19, 21, 33, 35, 48, 54, 56	15, 4	1, 16, 18, 3, 37, 41	1, 16, 18, 3, 37, 41	24, 9	10, 28	1, 12, 14
UC7_SCL	IOD	Unified Communication Module UC7: I2C SCL signal	10, 13, 34, 36, 44, 46, 5, 50, 57, 8	11, 13, 16, 19, 23, 5	10, 12, 14, 19, 2, 27, 30, 32, 35	10, 12, 14, 19, 2, 27, 30, 32, 35	1, 10, 11, 13, 16, 7	1, 11, 15, 19, 7, 9	10, 15, 19, 2, 21, 24, 8
UC7_SDA	IOD	Unified Communication Module UC7: I2C SDA signal	11, 12, 33, 37, 43, 45, 51, 56, 6, 9	10, 12, 15, 20, 21, 22, 4	1, 11, 15, 18, 28, 31, 33, 34, 9	1, 11, 15, 18, 28, 31, 33, 34, 9	12, 14, 15, 24, 6, 9	10, 16, 17, 18, 28, 6, 8	1, 14, 20, 22, 23, 7, 9
UC8_PICO_TX	IO	Unified Communication Module UC8: SPI PICO or UART TX signal	10, 11, 20, 21, 3, 43, 45, 52, 54, 58, 60	10, 12, 17, 21	11, 16, 20, 22, 25, 32, 33, 9	11, 16, 20, 22, 25, 32, 33, 9	13, 14, 6	13, 17, 6, 8	12, 17, 21, 22, 7, 9
UC8_POCI	IO	Unified Communication Module UC8: SPI POCI signal	12, 2, 20, 59, 6, 9	16, 20, 22	21, 24, 28, 31, 34	21, 24, 28, 31, 34	12, 15	12, 16, 18	16, 20, 23
UC8_SCLK_RX	IOD	Unified Communication Module UC8: SPI SCLK or UART RX signal	10, 11, 13, 2, 21, 22, 4, 44, 46, 53, 55, 59, 61	11, 13, 14, 16, 18, 21, 23	10, 12, 17, 21, 23, 24, 26, 32, 33, 35	10, 12, 17, 21, 23, 24, 26, 32, 33, 35	13, 14, 16, 7, 8	12, 14, 17, 19, 7, 9	10, 13, 16, 18, 21, 22, 24, 8
UC11_RX	IO	Unified Communication Module UC11: UART RX signal	15, 18, 25, 4, 51, 7	18, 21, 25, 27	15, 26, 29, 37, 40, 44	15, 26, 29, 37, 40, 44	18, 20	14, 17, 21, 24	18, 21, 26, 28

**Table 6-8. Unified Communication Module (UniComm) Signal Descriptions (continued)**

SIGNAL NAME	PIN TYPE	DESCRIPTION	PM PIN	DGS28 PIN	PT PIN	RGZ PIN	RGE PIN	RUY PIN	RHB PIN
UC11_TX	IO	Unified Communication Module UC11: UART TX signal	14, 17, 24, 3, 50, 6	17, 20, 24, 26	14, 25, 28, 36, 39, 43	14, 25, 28, 36, 39, 43	17, 19	13, 16, 20, 23	17, 20, 25, 27
UC4_CS0_CTS	IO	Unified Communication Module UC4: SPI CS0 or UART CTS signal	11, 16, 27, 36, 4, 42, 44, 45, 54, 55, 7	11, 12, 14, 18, 21, 9	10, 11, 16, 17, 26, 29, 33, 38, 8	10, 11, 16, 17, 26, 29, 33, 38, 8	14, 5, 7, 8	14, 17, 5, 7, 8	12, 13, 18, 21, 22, 6, 8, 9
UC8_CS0	IO	Unified Communication Module UC8: SPI CS0 signal	1, 19, 3, 30, 42, 58, 6	1, 17, 20, 9	20, 25, 28, 41, 46, 8	20, 25, 28, 41, 46, 8	22, 5	13, 16, 25, 5	17, 20, 30, 6

**Table 6-9. Timer (TIMx) Signal Descriptions**

SIGNAL NAME	PIN TYPE	DESCRIPTION	PM PIN	DGS28 PIN	PT PIN	RGZ PIN	RGE PIN	RUY PIN	RHB PIN
TIMA0_C0	IO	TIMA0 capture/compare 0 signal	17, 2, 28, 33, 42, 51, 54, 60	16, 24, 4, 9	1, 15, 16, 22, 24, 39, 8	1, 15, 16, 22, 24, 39, 8	17, 24, 5	12, 20, 28, 5	1, 12, 16, 25, 6
TIMA0_C1	IO	TIMA0 capture/compare 1 signal	18, 19, 34, 35, 43, 49, 52, 55, 61, 64	10, 14, 25, 5	13, 17, 2, 23, 3, 40, 41, 9	13, 17, 2, 23, 3, 40, 41, 9	1, 18, 6, 8	1, 21, 6	11, 13, 2, 26, 7
TIMA0_C2	IO	TIMA0 capture/compare 2 signal	12, 14, 19, 43, 47, 49, 5, 52, 56, 64, 8	10, 15, 19, 22	13, 18, 27, 30, 34, 36, 41, 9	13, 18, 27, 30, 34, 36, 41, 9	11, 15, 6, 9	10, 15, 18, 6	11, 14, 19, 23, 7
TIMA0_C3	IO	TIMA0 capture/compare 3 signal	1, 10, 23, 24, 26, 28, 35, 44, 5, 50	11, 19, 26, 28	10, 14, 27, 3, 32, 42, 43, 45	10, 14, 27, 3, 32, 42, 43, 45	13, 19, 21, 7	15, 22, 23, 7	19, 21, 27, 29, 8
TIMA0_C0N	O	TIMA0 capture/compare 0 complementary output	18, 29, 55, 61	14, 25	17, 23, 40	17, 23, 40	18, 8	21	13, 26
TIMA0_C1N	O	TIMA0 capture/compare 1 complementary output	1, 23, 26, 44, 53	11, 28	10, 42, 45	10, 42, 45	21, 7	22, 7	29, 8
TIMA0_C2N	O	TIMA0 capture/compare 2 complementary output	13, 15, 42, 46, 48, 53, 57, 6, 9	13, 16, 20, 23, 9	12, 19, 28, 31, 35, 37, 8	12, 19, 28, 31, 35, 37, 8	10, 12, 16, 5	11, 16, 19, 5, 9	10, 15, 20, 24, 6
TIMA0_C3N	O	TIMA0 capture/compare 3 complementary output	11, 25, 29, 3, 30, 39, 42, 51, 6	1, 17, 20, 21, 27, 9	15, 25, 28, 33, 44, 46, 5, 8	15, 25, 28, 33, 44, 46, 5, 8	14, 20, 22, 5	13, 16, 17, 24, 25, 5	17, 20, 22, 28, 30, 6
TIMA_FAL0	I	TIMA fault input 0	22, 27, 30, 35, 42, 46, 54, 57	1, 13, 16, 9	12, 16, 19, 3, 46, 8	12, 16, 19, 3, 46, 8	10, 22, 5	11, 25, 5, 9	10, 12, 15, 30, 6

**Table 6-9. Timer (TIMx) Signal Descriptions (continued)**

SIGNAL NAME	PIN TYPE	DESCRIPTION	PM PIN	DGS28 PIN	PT PIN	RGZ PIN	RGE PIN	RUY PIN	RHB PIN
TIMA_FAL1	I	TIMA fault input 1	19, 27, 33, 42, 45, 56, 64	12, 15, 4, 9	1, 11, 18, 41, 8	1, 11, 18, 41, 8	24, 5, 9	10, 28, 5, 8	1, 14, 6, 9
TIMA_FAL2	I	TIMA fault input 2	27, 31, 34, 54, 58	2, 5	16, 2, 20, 47	16, 2, 20, 47	1	1, 26	12, 2, 31
TIMG14_C0	IO	TIMG14 capture/compare 0 signal	12, 14, 2, 24, 33, 45, 47, 5, 52, 56, 62	12, 15, 16, 19, 22, 26, 4	1, 11, 18, 24, 27, 34, 36, 43	1, 11, 18, 24, 27, 34, 36, 43	15, 19, 24, 9	10, 12, 15, 18, 23, 28, 8	1, 14, 16, 19, 23, 27, 9
TIMG14_C1	IO	TIMG14 capture/compare 1 signal	13, 15, 25, 3, 34, 46, 48, 53, 57, 6, 63	13, 16, 17, 20, 23, 27, 5	12, 19, 2, 25, 28, 35, 37, 44	12, 19, 2, 25, 28, 35, 37, 44	1, 10, 16, 20	1, 11, 13, 16, 19, 24, 9	10, 15, 17, 2, 20, 24, 28
TIMG14_C2	IO	TIMG14 capture/compare 2 signal	10, 16, 17, 2, 20, 24, 3, 30, 34, 36, 43, 45, 49, 58, 62, 8	1, 10, 12, 16, 17, 24, 26, 5	11, 13, 2, 20, 24, 25, 30, 32, 38, 39, 43, 46, 9	11, 13, 2, 20, 24, 25, 30, 32, 38, 39, 43, 46, 9	1, 11, 13, 17, 19, 22, 6	1, 12, 13, 20, 23, 25, 6, 8	11, 16, 17, 2, 21, 25, 27, 30, 7, 9
TIMG14_C3	IO	TIMG14 capture/compare 3 signal	11, 18, 21, 25, 31, 34, 37, 4, 42, 44, 46, 49, 59, 63	11, 13, 18, 2, 21, 25, 27, 5, 9	10, 12, 13, 2, 21, 26, 33, 40, 44, 47, 8	10, 12, 13, 2, 21, 26, 33, 40, 44, 47, 8	1, 14, 18, 20, 5, 7	1, 14, 17, 21, 24, 26, 5, 7, 9	10, 11, 18, 2, 22, 26, 28, 31, 6, 8
TIMG1_C0	IO	TIMG1 capture/compare 0 signal	14, 17, 26, 28, 36, 45, 50, 52, 58, 60, 62	12, 24, 28	11, 14, 20, 22, 36, 39, 45	11, 14, 20, 22, 36, 39, 45	17, 21	20, 8	25, 29, 9
TIMG1_C1	IO	TIMG1 capture/compare 1 signal	15, 18, 29, 30, 37, 46, 51, 53, 59, 61, 63	1, 13, 25	12, 15, 21, 23, 37, 40, 46	12, 15, 21, 23, 37, 40, 46	18, 22	21, 25, 9	10, 26, 30
TIMG2_C0	IO	TIMG2 capture/compare 0 signal	10, 24, 3, 30, 35, 43, 55	1, 10, 14, 17, 26	17, 25, 3, 32, 43, 46, 9	17, 25, 3, 32, 43, 46, 9	13, 19, 22, 6, 8	13, 23, 25, 6	13, 17, 21, 27, 30, 7
TIMG2_C1	IO	TIMG2 capture/compare 1 signal	11, 16, 25, 31, 39, 4, 42, 44, 49, 54	11, 18, 2, 21, 27, 9	10, 13, 16, 26, 33, 38, 44, 47, 5, 8	10, 13, 16, 26, 33, 38, 44, 47, 5, 8	14, 20, 5, 7	14, 17, 24, 26, 5, 7	11, 12, 18, 22, 28, 31, 6, 8

**Table 6-10. Clock Module (CKM) Signal Descriptions**

SIGNAL NAME	PIN TYPE	DESCRIPTION	PM PIN	DGS28 PIN	PT PIN	RGZ PIN	RGE PIN	RUY PIN	RHB PIN
CLK_OUT	O	CLK_OUT digital clock output from the PMCU	18, 31, 39, 4, 49, 55, 56, 63, 7	14, 15, 18, 2, 21, 25	13, 17, 18, 26, 29, 40, 47, 5	13, 17, 18, 26, 29, 40, 47, 5	18, 8, 9	10, 14, 17, 21, 26	11, 13, 14, 18, 21, 26, 31
FCC_IN	I	Frequency clock counter (FCC) input signal	2, 27, 28, 33, 45, 49, 5, 9	12, 16, 19, 4	1, 11, 13, 24, 27, 31	1, 11, 13, 24, 27, 31	12, 24	12, 15, 28, 8	1, 11, 16, 19, 9
HFCLKIN	I	High frequency clock digital clock input signal	46, 50, 54	13	12, 14, 16	12, 14, 16		9	10, 12
HFXIN	A	High frequency crystal oscillator (HFXT) signal	45	12	11	11		8	9
HFXOUT	A	High frequency crystal oscillator (HFXT) signal	46	13	12	12		9	10
LFCLKIN	I	Low frequency clock digital clock input signal	44	11	10	10	7	7	8
LFXIN	A	Low frequency crystal oscillator (LFXT) signal	43	10	9	9	6	6	7
LFXOUT	A	Low frequency crystal oscillator (LFXT) signal	44	11	10	10	7	7	8

**Table 6-11. System Controller (SYSCTL) Signal Descriptions**

SIGNAL NAME	PIN TYPE	DESCRIPTION	PM PIN	DGS28 PIN	PT PIN	RGZ PIN	RGE PIN	RUY PIN	RHB PIN
BEEP	O	Beep output	33	4	1	1	24	28	1
NRST	RESET	Active-low reset signal (must be logic high for the device to start)	38	6	4	4	2	2	3
VCORE	PWR	VCORE capacitor connection	32	3	48	48	23	27	32
VDD	PWR	VDD supply	40	7	6	6	3	3	4
VSS	PWR	VSS (ground)	41	8	7	7	4	4	5

**Table 6-12. Serial Wire Debug (SWD) Signal Descriptions**

SIGNAL NAME	PIN TYPE	DESCRIPTION	PM PIN	DGS28 PIN	PT PIN	RGZ PIN	RGE PIN	RUY PIN	RHB PIN
SWCLK	I	Serial wire debug interface clock input signal	13	23	35	35	16	19	24
SWDIO	IO	Serial wire debug interface data input/output signal	12	22	34	34	15	18	23

**Table 6-13. Real-time Clock (RTC) Signal Descriptions**

SIGNAL NAME	PIN TYPE	DESCRIPTION	PM PIN	DGS28 PIN	PT PIN	RGZ PIN	RGE PIN	RUY PIN	RHB PIN
RTC_OUT	O	Real-time clock output signal	3, 31, 55, 6	14, 17, 2, 20	17, 25, 28, 47	17, 25, 28, 47	8	13, 16, 26	13, 17, 20, 31

## 6.4 Connections for Unused Pins

Table 6-14 lists the correct termination of unused pins.

**Table 6-14. Connection of Unused Pins**

PIN <sup>(1)</sup>	POTENTIAL	COMMENT
PAx and PBx	Open	Set corresponding pin functions to GPIO (PINCMx.PF = 0x1) and configure unused pins to output low or input with internal pullup/pulldown resistor.
NRST	VCC	NRST is an active-low reset signal; it must be pulled high to VCC or the device will not start, for more information refer to <a href="#">Section 9.1</a>

(1) Any unused pin with a function that is shared with general-purpose I/O should follow the "PAx and PBx" unused pin connection guidelines.

## 7 Specifications

### 7.1 Absolute Maximum Ratings

over operating free-air temperature range (unless otherwise noted)<sup>(1)</sup>

			MIN	MAX	UNIT
VDD	Supply voltage	At VDD pin, with respect to VSS	-0.3	4.1	V
V <sub>I</sub>	Input voltage	Applied to any 5-V tolerant open-drain pins	-0.3	V <sub>DD</sub> + 3.6 (5.5 MAX)	V
V <sub>I</sub>	Input voltage	Applied to any common tolerance pins	-0.3	V <sub>DD</sub> + 0.3 (4.1 MAX)	V
I <sub>VDD</sub>	Current into VDD pin (source)	-40°C ≤ T <sub>J</sub> ≤ 130°C		80	mA
		-40°C ≤ T <sub>J</sub> ≤ 85°C		100	
I <sub>VSS</sub>	Current out of VSS pin (sink)	-40°C ≤ T <sub>J</sub> ≤ 130°C		80	mA
		-40°C ≤ T <sub>J</sub> ≤ 85°C		100	
I <sub>IO</sub>	Current for LDIO pin	Current sunk or sourced by LDIO pin		3	mA
	Current for SDIO pin	Current sunk or sourced by SDIO pin		6	
	Current for HDIO pin	Current sunk or sourced by HDIO pin		20	
	Current for ODIO pin	Current sunk by ODIO pin		20	
I <sub>D</sub>	Supported diode current	Diode current on pin supporting LCD function	-2	2	mA
		Diode current on pin not supporting LCD function (excluding Open Drain IO)	-2	0.05	
T <sub>J</sub>	Junction temperature		-40	130	°C
T <sub>stg</sub>	Storage temperature <sup>(2)</sup>		-40	150	°C

- (1) Operation outside the Absolute Maximum Ratings may cause permanent device damage. Absolute Maximum Ratings do not imply functional operation of the device at these or any other conditions beyond those listed under Recommended Operating Conditions. If used outside the Recommended Operating Conditions but within the Absolute Maximum Ratings, the device may not be fully functional, and this may affect device reliability, functionality, performance, and shorten the device lifetime.
- (2) Higher temperatures may be applied during board soldering according to the current JEDEC J-STD-020 specification with peak reflow temperatures not higher than classified on the device label on the shipping boxes or reels.

### 7.2 ESD Ratings

			VALUE	UNIT
V <sub>(ESD)</sub>	Electrostatic discharge	Human body model (HBM), per ANSI/ESDA/ JEDEC JS-001, all pins <sup>(1)</sup>	±2000	V
		Charged device model (CDM), per JEDEC specification JESD22-C101, all pins <sup>(2)</sup>	±500	

- (1) JEDEC document JEP155 states that 500-V HBM allows safe manufacturing with a standard ESD control process.
- (2) JEDEC document JEP157 states that 250-V CDM allows safe manufacturing with a standard ESD control process.

### 7.3 Recommended Operating Conditions

over operating free-air temperature range (unless otherwise noted)

		MIN	NOM	MAX	UNIT
VDD	Supply voltage <sup>(4)</sup>	1.62 <sup>(5)</sup>		3.6	V
VCORE	Voltage on VCORE pin <sup>(2)</sup>		1.35		V
C <sub>VDD</sub>	Capacitor placed between VDD and VSS <sup>(1)</sup>		10		uF
C <sub>VCORE</sub>	Capacitor placed between VCORE and VSS <sup>(1) (2)</sup>		470		nF
T <sub>A</sub>	Ambient temperature	-40		125	°C
T <sub>J</sub>	Max junction temperature			130	°C
f <sub>MCLK</sub>	MCLK, CPUCLK, ULPCLK frequency with 1 flash wait state <sup>(3)</sup>			32	MHz

over operating free-air temperature range (unless otherwise noted)

		MIN	NOM	MAX	UNIT
f <sub>MCLK</sub>	MCLK, CPUCLK, ULPCLK frequency with 0 flash wait states <sup>(3)</sup>			24	MHz

- (1) Connect C<sub>VDD</sub> and C<sub>VCORE</sub> between VDD/VSS and V<sub>CORE</sub>/VSS, respectively, as close to the device pins as possible. A low-ESR capacitor with at least the specified value and tolerance of ±20% or better is required for C<sub>VDD</sub>.
- (2) The V<sub>CORE</sub> pin must only be connected to C<sub>VCORE</sub>. Do not supply any voltage or apply any external load to the V<sub>CORE</sub> pin.
- (3) Wait states are managed automatically by the system controller (SYSC<sub>CTL</sub>) and do not need to be configured by application software.
- (4) There is no dependency on MCLK frequency with respect to VDD recommended operating range.
- (5) Functionality is ensured down to V<sub>BOR0-(min)</sub>.

## 7.4 Thermal Information

THERMAL METRIC <sup>(1)</sup>		PACKAGE	VALUE	UNIT
R <sub>θJA</sub>	Junction-to-ambient thermal resistance	LQFP-64 (PM)	56.3	°C/W
R <sub>θJC(top)</sub>	Junction-to-case (top) thermal resistance		24.9	°C/W
R <sub>θJB</sub>	Junction-to-board thermal resistance		37.7	°C/W
Ψ <sub>JT</sub>	Junction-to-top characterization parameter		2.0	°C/W
Ψ <sub>JB</sub>	Junction-to-board characterization parameter		37.4	°C/W
R <sub>θJC(bot)</sub>	Junction-to-case (bottom) thermal resistance		N/A	°C/W
R <sub>θJA</sub>	Junction-to-ambient thermal resistance	LQFP-48 (PT)	63.3	°C/W
R <sub>θJC(top)</sub>	Junction-to-case (top) thermal resistance		29.5	°C/W
R <sub>θJB</sub>	Junction-to-board thermal resistance		41.0	°C/W
Ψ <sub>JT</sub>	Junction-to-top characterization parameter		3.2	°C/W
Ψ <sub>JB</sub>	Junction-to-board characterization parameter		40.5	°C/W
R <sub>θJC(bot)</sub>	Junction-to-case (bottom) thermal resistance		N/A	°C/W
R <sub>θJA</sub>	Junction-to-ambient thermal resistance	VQFN-48 (RGZ)	31.6	°C/W
R <sub>θJC(top)</sub>	Junction-to-case (top) thermal resistance		22.7	°C/W
R <sub>θJB</sub>	Junction-to-board thermal resistance		14.9	°C/W
Ψ <sub>JT</sub>	Junction-to-top characterization parameter		1.0	°C/W
Ψ <sub>JB</sub>	Junction-to-board characterization parameter		14.9	°C/W
R <sub>θJC(bot)</sub>	Junction-to-case (bottom) thermal resistance		6.6	°C/W
R <sub>θJA</sub>	Junction-to-ambient thermal resistance	VQFN-32 (RHB)	36.0	°C/W
R <sub>θJC(top)</sub>	Junction-to-case (top) thermal resistance		28.0	°C/W
R <sub>θJB</sub>	Junction-to-board thermal resistance		16.0	°C/W
Ψ <sub>JT</sub>	Junction-to-top characterization parameter		0.9	°C/W
Ψ <sub>JB</sub>	Junction-to-board characterization parameter		16.0	°C/W
R <sub>θJC(bot)</sub>	Junction-to-case (bottom) thermal resistance		4.6	°C/W
R <sub>θJA</sub>	Junction-to-ambient thermal resistance	VSSOP-28 (DGS28)	74.3	°C/W
R <sub>θJC(top)</sub>	Junction-to-case (top) thermal resistance		29.6	°C/W
R <sub>θJB</sub>	Junction-to-board thermal resistance		35.8	°C/W
Ψ <sub>JT</sub>	Junction-to-top characterization parameter		1.7	°C/W
Ψ <sub>JB</sub>	Junction-to-board characterization parameter		35.6	°C/W
R <sub>θJC(bot)</sub>	Junction-to-case (bottom) thermal resistance		N/A	°C/W
R <sub>θJA</sub>	Junction-to-ambient thermal resistance	WQFN-28 (RUY)	44.5	°C/W
R <sub>θJC(top)</sub>	Junction-to-case (top) thermal resistance		32.1	°C/W
R <sub>θJB</sub>	Junction-to-board thermal resistance		20.0	°C/W
Ψ <sub>JT</sub>	Junction-to-top characterization parameter		0.8	°C/W
Ψ <sub>JB</sub>	Junction-to-board characterization parameter		20.0	°C/W
R <sub>θJC(bot)</sub>	Junction-to-case (bottom) thermal resistance		6.5	°C/W

THERMAL METRIC <sup>(1)</sup>		PACKAGE	VALUE	UNIT
$R_{\theta JA}$	Junction-to-ambient thermal resistance	VQFN-24 (RGE)	44.4	°C/W
$R_{\theta JC(top)}$	Junction-to-case (top) thermal resistance		37.2	°C/W
$R_{\theta JB}$	Junction-to-board thermal resistance		21.2	°C/W
$\Psi_{JT}$	Junction-to-top characterization parameter		1.2	°C/W
$\Psi_{JB}$	Junction-to-board characterization parameter		21.2	°C/W
$R_{\theta JC(bot)}$	Junction-to-case (bottom) thermal resistance		6.8	°C/W

- (1) For more information about traditional and new thermal metrics, see the [Semiconductor and IC Package Thermal Metrics](#) application report.

## 7.5 Supply Current Characteristics

### 7.5.1 RUN/SLEEP Modes

VDD=3.3V. All inputs tied to 0V or VDD. Outputs do not source or sink any current. All peripherals are disabled.

PARAMETER		MCLK	-40°C		25°C		85°C		105°C		125°C		UNIT
			TYP	MAX	TYP	MAX	TYP	MAX	TYP	MAX	TYP	MAX	
<b>RUN Mode</b>													
IDDRUN	MCLK=SYSOSC, CoreMark, execute from flash	32MHz	3.1		3.1		3.1		3.2		3.2		mA
IDDRUN, per MHz	MCLK=SYSOSC, While(1), execute from flash	32MHz	52	59	52	59	53	59	53	59	54	60	uA/MHz
	MCLK=SYSOSC, CoreMark, execute from flash	32MHz	97		98		98		98		99		
<b>SLEEP Mode</b>													
IDDSLEEP	MCLK=SYSOSC, CPU is halted	32MHz	1265	1426	1284	1429	1310	1481	1317	1488	1329	1472	uA
IDDSLEEP	MCLK=LFCLK, CPU is halted	32kHz	262	303	266	304	299	358	307	366	322	381	uA

### 7.5.2 STOP/STANDBY Modes

VDD=3.3V unless otherwise noted. All inputs tied to 0V or VDD. Outputs do not source or sink any current. All peripherals not noted are disabled.

PARAMETER		ULPCLK	-40°C		25°C		85°C		105°C		125°C		UNIT
			TYP	MAX	TYP	MAX	TYP	MAX	TYP	MAX	TYP	MAX	
<b>STOP Mode</b>													
IDDSTOP0	SYSOSC=32MHz, USE4MHZSTOP=0, DISABLESTOP=0	4MHz	397	447	403	451	411	455	414	458	418	463	uA
IDDSTOP2	SYSOSC off, DISABLESTOP=1, ULPCLK=LFCLK	32kHz	45	56	47	59	50	82	53	85	62	90	
<b>STANDBY Mode</b>													
IDDSTBY0	LFXT and RTC enabled	32kHz	2.14	3.5	2.14	3.5	3.7	24.3	6.3	27.0	15.0	33.1	uA
	LFOSC and IWDT enabled		1.9	2.3	2.0	2.4	3.6	25.6	6.3	28.5	15.0	34.4	uA
	LFXT and RTC enabled, IWDT enabled		2.5	3.5	2.5	3.5	4.0	24.9	6.7	27.6	15.1	33.1	uA
	STOPCLKSTBY=0, TIMG14 enabled		1.9	2.3	2.0	2.4	3.6	25.6	6.3	28.5	15.0	34.4	uA
IDDSTBY1	STOPCLKSTBY=1, TIMG14 enabled	1.5	1.8	1.6	1.9	3.2	24.8	5.9	27.7	14.6	34.0		
	STOPCLKSTBY=1, GPIOA enabled	1.5	1.9	1.6	1.9	3.2	24.8	5.9	27.7	14.7	34.0		

### 7.5.3 SHUTDOWN Mode

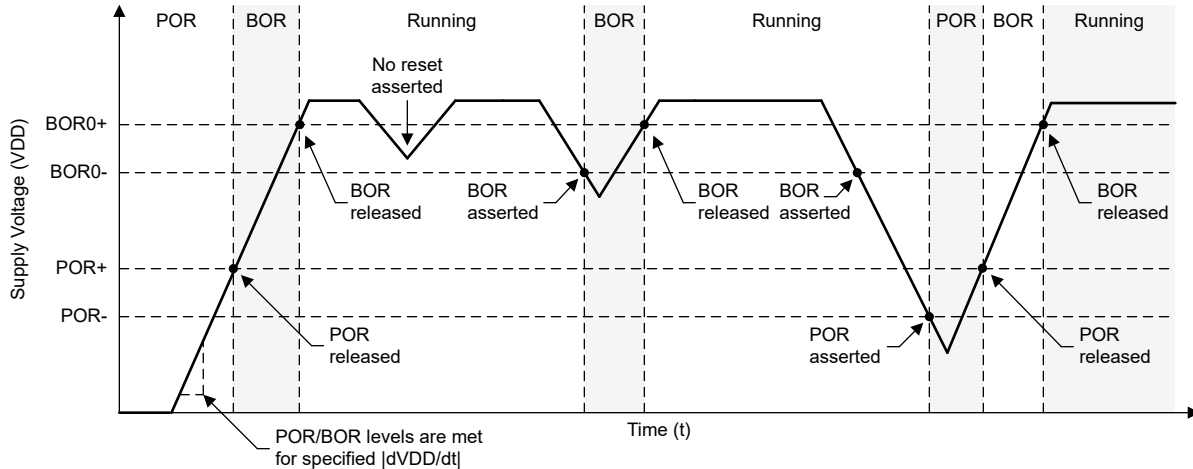
All inputs tied to 0V or VDD. Outputs do not source or sink any current. Core regulator is powered down.

PARAMETER		VDD	-40°C		25°C		85°C		105°C		125°C		UNIT
			TYP	MAX	TYP	MAX	TYP	MAX	TYP	MAX	TYP	MAX	
IDDSHDN	Supply current in SHUTDOWN mode	3.3V	46		81		669		1414		3606		nA

## 7.6 Power Supply Sequencing

### 7.6.1 Power Supply Ramp

Figure 7-1 gives the relationship of POR-, POR+, BOR0-, and BOR0+ during power-up and power-down.



**Figure 7-1. Power Cycle POR/BOR Conditions - VDD**

### 7.6.2 POR and BOR

over operating free-air temperature range (unless otherwise noted)

PARAMETER		TEST CONDITIONS	MIN	TYP	MAX	UNIT
dVDD/dt	VDD (supply voltage) slew rate	Rising			0.1	V/us
		Falling <sup>(1)</sup>			0.01	
dVDD/dt		Falling, STANDBY			0.1	V/ms
V <sub>POR+</sub>	Power-on reset voltage level	Rising	0.95	1.30	1.60	V
V <sub>POR-</sub>		Falling	0.9	1.25	1.55	V
V <sub>HYS, POR</sub>	POR hysteresis		30	58	74	mV
V <sub>BOR0+, COLD</sub>	Brown-out reset voltage level 0 (default level)	-40°C ≤ T <sub>j</sub> ≤ 125°C Cold start, rising	1.40	1.48	1.61	V
V <sub>BOR0+</sub>		Rising <sup>(1)</sup>	1.55	1.59	1.62	
V <sub>BOR0-</sub>		Falling <sup>(1)</sup>	1.54	1.58	1.61	
V <sub>BOR0, STBY</sub>	Brown-out reset voltage level 0 (default level)	STANDBY mode	1.51	1.57	1.61	
V <sub>BOR1+</sub>	Brown-out-reset voltage level 1	Rising <sup>(1)</sup>	2.13	2.17	2.21	V
V <sub>BOR1-</sub>		Falling <sup>(1)</sup>	2.10	2.14	2.18	
V <sub>BOR1, STBY</sub>	Brown-out-reset voltage level 1	STANDBY mode	2.06	2.13	2.20	V
V <sub>BOR2+</sub>	Brown-out-reset voltage level 2	Rising <sup>(1)</sup>	2.73	2.77	2.82	V
V <sub>BOR2-</sub>		Falling <sup>(1)</sup>	2.7	2.74	2.79	
V <sub>BOR2, STBY</sub>	Brown-out-reset voltage level 2	STANDBY mode	2.62	2.71	2.80	V
V <sub>BOR3+</sub>	Brown-out-reset voltage level 3	Rising <sup>(1)</sup>	2.88	2.96	3.04	V
V <sub>BOR3-</sub>		Falling <sup>(1)</sup>	2.85	2.93	3.01	
V <sub>BOR3, STBY</sub>	Brown-out-reset voltage level 3	STANDBY mode	2.82	2.92	3.02	V
V <sub>HYS, BOR</sub>	Brown-out reset hysteresis	Level 0		15	21	mV
		Levels 1-3		34	40	
T <sub>PD, BOR</sub>	BOR propagation delay	RUN/SLEEP/STOP mode			10	us
		STANDBY mode			100	us

(1) Device operating in RUN, SLEEP, or STOP mode.

## 7.7 Flash Memory Characteristics

over operating free-air temperature range (unless otherwise noted)

PARAMETER		TEST CONDITIONS	MIN	TYP	MAX	UNIT
<b>Supply</b>						
VDD <sub>PGM/ERASE</sub>	Program and erase supply voltage		1.62		3.6	V
IDDERASE	Supply current from VDD during erase operation	Supply current delta			10	mA
IDDPGM	Supply current from VDD during program operation	Supply current delta			10	mA
<b>Endurance</b>						
NWEC <sub>(LOWER)</sub>	Erase/program cycle endurance (lower 32kB flash) <sup>(1)</sup>		100			k cycles
NWEC <sub>(UPPER)</sub>	Erase/program cycle endurance (remaining flash) <sup>(1)</sup>		10			k cycles
NE <sub>(MAX)</sub>	Total erase operations before failure <sup>(2)</sup>		802			k erase operations
NW <sub>(MAX)</sub>	Write operations per word line before sector erase <sup>(3)</sup>				83	write operations
<b>Retention</b>						
t <sub>RET_85</sub>	Flash memory data retention	-40°C ≤ T <sub>j</sub> ≤ 85°C	60			years
t <sub>RET_105</sub>	Flash memory data retention	-40°C ≤ T <sub>j</sub> ≤ 105°C	11.4			years
<b>Program and Erase Timing</b>						
t <sub>PROG (WORD, 64)</sub>	Program time for flash word <sup>(4) (6)</sup>			50	275	μs
t <sub>PROG (SEC, 64)</sub>	Program time for 1kB sector <sup>(5) (6)</sup>			6.4		ms
t <sub>ERASE (SEC)</sub>	Sector erase time	≤2k erase/program cycles, T <sub>j</sub> ≥ 25°C		4	20	ms
t <sub>ERASE (SEC)</sub>	Sector erase time	≤10k erase/program cycles, T <sub>j</sub> ≥ 25°C		20	150	ms
t <sub>ERASE (SEC)</sub>	Sector erase time	≤10k erase/program cycles		20	200	ms
t <sub>ERASE (BANK)</sub>	Bank erase time	≤10k erase/program cycles		22	220	ms

- (1) The lower 32kB flash address space supports higher erase/program endurance to enable EEPROM emulation applications. On devices with ≤32kB flash memory, the entire flash memory supports NWEC<sub>(LOWER)</sub> erase/program cycles.
- (2) Total number of cumulative erase operations supported by the flash before failure. A sector erase or bank erase operation is considered to be one erase operation.
- (3) Maximum number of write operations allowed per word line before the word line must be erased. If additional writes to the same word line are required, a sector erase is required once the maximum number of write operations per word line is reached.
- (4) Program time is defined as the time from when the program command is triggered until the command completion interrupt flag is set in the flash controller.
- (5) Sector program time is defined as the time from when the first word program command is triggered until the final word program command completes and the interrupt flag is set in the flash controller. This time includes the time needed for software to load each flash word (after the first flash word) into the flash controller during programming of the sector.
- (6) Flash word size is 64 data bits (8 bytes). On devices with ECC, the total flash word size is 72 bits (64 data bits plus 8 ECC bits).

## 7.8 Timing Characteristics

VDD=3.3V, T<sub>a</sub>=25 °C (unless otherwise noted)

PARAMETER		TEST CONDITIONS	MIN	TYP	MAX	UNIT
<b>Wakeup Timing</b>						
t <sub>WAKE, SLEEP</sub>	Wakeup time from SLEEP0 to RUN <sup>(1)</sup>			2		cycles
	Wakeup time from SLEEP1 to RUN <sup>(1)</sup>			1.6		us
	Wakeup time from SLEEP2 to RUN <sup>(1)</sup>			2.2		us
t <sub>WAKE, STOP</sub>	Wakeup time from STOP0 to RUN (SYSOSC enabled) <sup>(1)</sup>			7.2		us
	Wakeup time from STOP2 to RUN (SYSOSC disabled) <sup>(1)</sup>			8.1		us

VDD=3.3V, T<sub>a</sub>=25 °C (unless otherwise noted)

PARAMETER		TEST CONDITIONS	MIN	TYP	MAX	UNIT
t <sub>WAKE, STBY</sub>	Wakeup time from STANDBY0 to RUN (1)			10		us
	Wakeup time from STANDBY1 to RUN (1)			10		
	Wakeup time from SHUTDOWN to RUN	Fast boot enabled		283		us
	Wakeup time from SHUTDOWN to RUN	Fast boot disabled		310		us
<b>Asynchronous Fast Clock Request Timing</b>						
t <sub>DELAY</sub>	Delay time from edge of asynchronous request to first 32MHz MCLK edge	Mode is SLEEP1		0.3		
		Mode is SLEEP2		0.9		us
		Mode is STOP0		0.9		us
		Mode is STOP2		0.9		us
		Mode is STANDBY1		3.1		us
		Mode is STANDBY0		3.1		us
<b>Startup Timing</b>						
t <sub>START, RESET</sub>	Device cold start-up time from reset/power-up (2)	Fast boot enabled		284		us
		Fast boot disabled		325		us
<b>NRST Timing</b>						
t <sub>RST, BOOTRST</sub>	Minimum pulse length on NRST pin to generate BOOTRST	ULPCLK≥4MHz		2		us
		ULPCLK=32kHz		100		us
t <sub>RST, POR</sub>	Minimum pulse length on NRST pin to generate POR			1		s

- (1) The wake-up time is measured from the edge of an external signal (GPIO wake-up event) to the time that the first CPU instruction is executed, with the GPIO glitch filter disabled (FILTEREN=0x0) and fast wake enabled (FASTWAKEONLY=1)
- (2) The start-up time is measured from the time that VDD crosses VBOR0+ (cold start-up) to the time that the first instruction of the user program is executed.

## 7.9 Clock Specifications

### 7.9.1 System Oscillator (SYSOSC)

Over operating free-air temperature range (unless otherwise noted). Test conditions indicate lifetime operation under the listed conditions.

PARAMETER		TEST CONDITIONS	MIN	TYP	MAX	UNIT
f <sub>SYSOSC</sub>	Factory trimmed SYSOSC frequency	SYSOSCCFG.FREQ=00 (BASE)		32		MHz
f <sub>SYSOSC</sub>	SYSOSC frequency accuracy when frequency correction loop (FCL) is enabled	SETUSEFCL=1, T <sub>a</sub> = 25 °C	0		1	%
f <sub>SYSOSC</sub>		SETUSEFCL=1, -40 °C ≤ T <sub>a</sub> ≤ 125 °C	-2.1		1.6	
f <sub>SYSOSC</sub>	SYSOSC accuracy when frequency correction loop (FCL) is disabled, 32MHz	SETUSEFCL=0, SYSOSCCFG.FREQ=00, -40 °C ≤ T <sub>a</sub> ≤ 125 °C	-2.5		2.5	%
t <sub>settle, SYSOSC</sub>	Settling time to target accuracy (1)	SETUSEFCL=1			40	us

- (1) When SYSOSC is waking up (for example, when exiting a low power mode) and FCL is enabled, the SYSOSC will initially undershoot the target frequency f<sub>SYSOSC</sub> by an additional error for the time t<sub>settle, SYSOSC</sub>, after which the target accuracy is achieved.

### 7.9.2 Low Frequency Oscillator (LFOSC)

over operating free-air temperature range (unless otherwise noted)

PARAMETER		TEST CONDITIONS	MIN	TYP	MAX	UNIT
f <sub>LFOSC</sub>	LFOSC frequency			32768		Hz
	LFOSC accuracy	-40 °C ≤ T <sub>a</sub> ≤ 125 °C	-5		5	%
		-40 °C ≤ T <sub>a</sub> ≤ 85 °C	-3		3	%
I <sub>LFOSC</sub>	LFOSC current consumption			300		nA
t <sub>start, LFOSC</sub>	LFOSC start-up time			1		ms

### 7.9.3 Low Frequency Crystal/Clock

over operating free-air temperature range (unless otherwise noted)

PARAMETER		TEST CONDITIONS	MIN	TYP	MAX	UNIT
<b>Low frequency crystal oscillator (LFXT)</b>						
f <sub>LFXT</sub>	LFXT frequency			32768		Hz
DC <sub>LFXT</sub>	LFXT duty cycle		30		70	%
OA <sub>LFXT</sub>	LFXT crystal oscillation allowance			419		kΩ
C <sub>L, eff</sub>	Integrated effective load capacitance <sup>(1)</sup>			1		pF
t <sub>start, LFXT</sub>	LFXT start-up time <sup>(2)</sup>			200		ms
I <sub>LFXT</sub>	LFXT current consumption	XT1DRIVE=0, LOWCAP=1		300		nA
<b>Low frequency digital clock input (LFCLK_IN)</b>						
f <sub>LFIN</sub>	LFCLK_IN frequency <sup>(3)</sup>	SETUSEEXLF=1	29491	32768	36045	Hz
DC <sub>LFIN</sub>	LFCLK_IN duty cycle <sup>(3)</sup>	SETUSEEXLF=1	40		60	%
<b>LFCLK Monitor</b>						
f <sub>FAULTLF</sub>	LFCLK monitor fault frequency <sup>(4)</sup>	MONITOR=1	2800	4200	8400	Hz

- (1) This includes parasitic bond and package capacitance (≈2pF per pin), calculated as  $C_{LFXIN} \times C_{LFXOUT} / (C_{LFXIN} + C_{LFXOUT})$ , where  $C_{LFXIN}$  and  $C_{LFXOUT}$  are the total capacitance at LFXIN and LFXOUT, respectively.
- (2) The user must ensure that the crystal is properly rated to support the start-up drive load (e.g. 0.1uW)
- (3) The digital clock input (LFCLK\_IN) accepts a logic level square wave clock.
- (4) The LFCLK monitor may be used to monitor the LFXT or LFCLK\_IN. It will always fault below the MIN fault frequency, and will never fault above the MAX fault frequency.

### 7.9.4 High Frequency Crystal/Clock

over operating free-air temperature range (unless otherwise noted)

PARAMETER		TEST CONDITIONS	MIN	TYP	MAX	UNIT
<b>High frequency crystal oscillator (HFXT)</b>						
f <sub>HFXT</sub>	HFXT frequency	HFXTTRSEL=00	4		8	MHz
f <sub>HFXT</sub>	HFXT frequency	HFXTTRSEL=01	8.01		16	MHz
f <sub>HFXT</sub>	HFXT frequency	HFXTTRSEL=10	16.01		32	MHz
DC <sub>HFXT</sub>	HFXT duty cycle	HFXTTRSEL=00	40		65	%
DC <sub>HFXT</sub>	HFXT duty cycle	HFXTTRSEL=01	40		60	%
DC <sub>HFXT</sub>	HFXT duty cycle	HFXTTRSEL=10	40		60	%
OA <sub>HFXT</sub>	HFXT crystal oscillation allowance	HFXTTRSEL=00 (4 to 8MHz range)		2		kΩ
C <sub>L, eff</sub>	Integrated effective load capacitance <sup>(1)</sup>			1		pF

over operating free-air temperature range (unless otherwise noted)

PARAMETER		TEST CONDITIONS	MIN	TYP	MAX	UNIT
$t_{\text{start, HFXT}}$	HFXT start-up time <sup>(2)</sup>	HFXTSEL=10, 32MHz crystal		0.5		ms
$I_{\text{HFXT}}$	HFXT current consumption <sup>(2)</sup>	$f_{\text{HFXT}}=4\text{MHz}$ , $R_m=300\Omega$ , $C_L=12\text{pF}$		100		$\mu\text{A}$
$I_{\text{HFXT}}$	HFXT current consumption <sup>(2)</sup>	$f_{\text{HFXT}}=32\text{MHz}$ , $R_m=30\Omega$ , $C_L=12\text{pF}$ , $C_m=6.26\text{fF}$ , $L_m=1.76\text{mH}$		600		$\mu\text{A}$
<b>High frequency digital clock input (HFCLK_IN)</b>						
$f_{\text{HFIN}}$	HFCLK_IN frequency <sup>(3)</sup>	USEEXTHFCLK =1	4		32	MHz
$DC_{\text{HFIN}}$	HFCLK_IN duty cycle <sup>(3)</sup>	USEEXTHFCLK =1	40		60	%

- (1) This includes parasitic bond and package capacitance ( $\approx 2\text{pF}$  per pin), calculated as  $C_{\text{HFXTIN}} \times C_{\text{HFXTOUT}} / (C_{\text{HFXTIN}} + C_{\text{HFXTOUT}})$ , where  $C_{\text{HFXTIN}}$  and  $C_{\text{HFXTOUT}}$  are the total capacitance at HFXTIN and HFXTOUT, respectively.
- (2) The HFXT startup time ( $t_{\text{start, HFXT}}$ ) is measured from the time the HFXT is enabled until stable oscillation for a typical crystal. Start-up time is dependent upon crystal frequency and crystal specifications. Refer to the HFXT section of the [MSPM0 H-Series 32-MHz Microcontrollers Technical Reference Manual](#). Current consumption increases with higher RSEL and start up time is decreases with higher RSEL.
- (3) The digital clock input (HFCLK\_IN) accepts a logic level square wave clock.

## 7.10 Digital IO

### 7.10.1 Electrical Characteristics

over recommended ranges of supply voltage and operating free-air temperature (unless otherwise noted)

PARAMETER		TEST CONDITIONS		MIN	TYP	MAX	UNIT
$V_{\text{IH}}$	High level input voltage	ODIO <sup>(1)</sup>	$V_{\text{DD}} \geq 1.62\text{V}$	$0.7 \times V_{\text{DD}}$		5.5	V
			$V_{\text{DD}} \geq 2.7\text{V}$	2	5.5		
		All I/O except ODIO & Reset	$V_{\text{DD}} \geq 1.62\text{V}$	$0.7 \times V_{\text{DD}}$		$V_{\text{DD}} + 0.3$	
$V_{\text{IL}}$	Low level input voltage	ODIO	$V_{\text{DD}} \geq 1.62\text{V}$	-0.3		$0.3 \times V_{\text{DD}}$	V
			$V_{\text{DD}} \geq 2.7\text{V}$	-0.3		0.8	
		All I/O except ODIO & Reset	$V_{\text{DD}} \geq 1.62\text{V}$	-0.3		$0.3 \times V_{\text{DD}}$	
$V_{\text{HYS}}$	Hysteresis	ODIO		$0.05 \times V_{\text{DD}}$			V
		All I/O except ODIO		$0.1 \times V_{\text{DD}}$			
$I_{\text{Ikg}}$	High-Z leakage current	LDIO (except PA12) <sup>(2) (3)</sup>				$\pm 100$ <sup>(4)</sup>	nA
$I_{\text{Ikg}}$	High-Z leakage current	LDIO (PA12 only)				$\pm 300$ <sup>(4)</sup>	nA
$I_{\text{Ikg}}$	High-Z leakage current	SDIO <sup>(2) (3)</sup>	$V_{\text{pad}} \leq V_{\text{DD}}$			$\pm 130$ <sup>(4)</sup>	nA
$R_{\text{PU}}$	Pull up resistance	All I/O except ODIO			40		k $\Omega$
$R_{\text{PD}}$	Pull down resistance				40		k $\Omega$

over recommended ranges of supply voltage and operating free-air temperature (unless otherwise noted)

PARAMETER		TEST CONDITIONS		MIN	TYP	MAX	UNIT
V <sub>OH</sub>	High level output voltage	LDIO	VDD ≥ 2.7V,  I <sub>IO</sub>   <sub>max</sub> = 3mA VDD ≥ 1.71V,  I <sub>IO</sub>   <sub>max</sub> = 1mA VDD ≥ 1.62V,  I <sub>IO</sub>   <sub>max</sub> = 0.75mA	VDD-0.4			V
		SDIO	VDD ≥ 2.7V,  I <sub>IO</sub>   <sub>max</sub> = 6mA VDD ≥ 1.71V,  I <sub>IO</sub>   <sub>max</sub> = 2mA VDD ≥ 1.62V,  I <sub>IO</sub>   <sub>max</sub> = 1.5mA	VDD-0.4			V
		HDIO	VDD ≥ 2.7V, DRV = 1,  I <sub>IO</sub>   <sub>max</sub> = 20mA VDD ≥ 2.7V, DRV = 0,  I <sub>IO</sub>   <sub>max</sub> = 6mA VDD ≥ 1.71V, DRV = 1,  I <sub>IO</sub>   <sub>max</sub> = 10mA VDD ≥ 1.71V, DRV = 0,  I <sub>IO</sub>   <sub>max</sub> = 2mA	VDD-0.4			V
V <sub>OL</sub>	Low level output voltage	ODIO	VDD ≥ 2.7V, I <sub>OL</sub> max = 8mA VDD ≥ 1.71V, I <sub>OL</sub> max = 4mA			0.4	V
		SDIO	VDD ≥ 2.7V,  I <sub>IO</sub>   <sub>max</sub> = 6mA VDD ≥ 1.71V,  I <sub>IO</sub>   <sub>max</sub> = 2mA VDD ≥ 1.62V,  I <sub>IO</sub>   <sub>max</sub> = 1.5mA			0.4	
		HDIO	VDD ≥ 2.7V, DRV = 1,  I <sub>IO</sub>   <sub>max</sub> = 20mA VDD ≥ 2.7V, DRV = 0,  I <sub>IO</sub>   <sub>max</sub> = 6mA VDD ≥ 1.71V, DRV = 1,  I <sub>IO</sub>   <sub>max</sub> = 10mA VDD ≥ 1.71V, DRV = 0,  I <sub>IO</sub>   <sub>max</sub> = 2mA			0.4	
		LDIO	VDD ≥ 2.7V,  I <sub>IO</sub>   <sub>max</sub> = 3mA VDD ≥ 1.71V,  I <sub>IO</sub>   <sub>max</sub> = 1mA VDD ≥ 1.62V,  I <sub>IO</sub>   <sub>max</sub> = 0.75mA			0.4	

- (1) I/O Types: ODIO = 5V Tolerant Open-Drain , SDIO = Standard-Drive , HSIO = High-Speed
- (2) The leakage current is measured with VSS or VDD applied to the corresponding pin(s), unless otherwise noted.
- (3) The leakage of the digital port pins is measured individually. The port pin is selected for input and the pullup/pulldown resistor is disabled.
- (4) This value is for the IO not muxed with any analog inputs. If it is muxed with analog inputs then the leakage can be as high as 100nA.

### 7.10.2 Switching Characteristics

over recommended ranges of supply voltage and operating free-air temperature (unless otherwise noted)

PARAMETER		TEST CONDITIONS		MIN	TYP	MAX	UNIT
f <sub>max</sub>	Port output frequency	ODIO	VDD ≥ 1.71V, FM <sup>+</sup> , CL = 20pF - 100pF			1	MHz
		LDIO <sup>(1)</sup>	VDD ≥ 1.71V, C <sub>L</sub> = 20pF			8	
			VDD ≥ 2.7V, CL = 20pF			16	
		SDIO <sup>(1)</sup>	VDD ≥ 1.71V, C <sub>L</sub> = 20pF			16	
			VDD ≥ 2.7V, CL = 20pF			32	
		HDIO <sup>(1)</sup>	VDD ≥ 2.7V, DRV=1, CL = 20pF			20	
			VDD ≥ 2.7V, DRV=0, CL = 20pF			20	
			VDD ≥ 1.7V, DRV=1, CL = 20pF			16	
VDD ≥ 1.7V, DRV=0, CL = 20pF				16			
t <sub>r</sub> , t <sub>f</sub>	Output rise/fall time	All output ports except ODIO	VDD ≥ 1.71V			0.3/f <sub>max</sub>	ns
t <sub>f</sub>	Output fall time	ODIO	VDD ≥ 1.71V, FM <sup>+</sup> , CL = 20pF-100pF	20*VDD/5.5		120	ns

- (1) I/O Types: ODIO = 5V Tolerant Open-Drain , SDIO = Standard-Drive , HSIO = High-Speed

## 7.11 Analog Mux VBOOST

over operating free-air temperature range (unless otherwise noted)

PARAMETER		TEST CONDITIONS	MIN	TYP	MAX	UNIT
$I_{VBST}$	VBOOST current adder	MCLK/ULPCLK is LFCLK		0.8		uA
		MCLK/ULPCLK is not LFCLK, SYSOSC frequency is 32MHz		30		
$t_{START,VBST}$	VBOOST startup time			12		us

## 7.12 ADC

### 7.12.1 Electrical Characteristics

over recommended ranges of supply voltage and operating free-air temperature (unless otherwise noted), all TYP values are measured at 25°C and all accuracy parameters are measured using 12-bit resolution mode (unless otherwise noted)

PARAMETER		TEST CONDITIONS	MIN	TYP	MAX	UNIT
$V_{IN(ADC)}$	Analog input voltage range <sup>(1)</sup>	Applies to all ADC analog input pins	0		VDD	V
$V_{R+}$	Positive ADC reference voltage	$V_{R+}$ sourced from VDD		VDD		V
		$V_{R+}$ sourced from external reference pin (VREF+)	1.4		VDD	V
		$V_{R+}$ sourced from internal reference (VREF)		VREF		V
$V_{R-}$	Negative ADC reference voltage		0		V	
$F_S$	ADC sampling frequency	RES = 0x0 (12-bit mode), External Reference			1.6	Msps
$F_S$	ADC sampling frequency	RES = 0x1 (10-bit mode), External Reference			1.7	Msps
$F_S$	ADC sampling frequency	RES = 0x2 (8-bit mode), External Reference			1.9	Msps
$I_{(ADC)}$	Operating supply current into VDD terminal	$F_S = 1\text{MSPS}$ , Internal reference OFF, $V_{R+} = VDD$		350		uA
		$F_S = 500\text{kpsps}$ , Internal reference ON, $V_{R+} = VREF = 2.5\text{V}$		300		
$C_{S/H}$	ADC sample-and-hold capacitance			0.22		pF
$R_{in}$	ADC sampling switch resistance			15		kΩ
ENOB	Effective number of bits	Internal reference, $V_{R+} = VREF = 2.5\text{V}$ , $F_{in} = 10\text{KHz}$	9.4	10		bit
		External reference, $F_{in} = 10\text{KHz}$ <sup>(2)</sup>	10	10.6		
ENOB	Effective number of bits	External reference, hardware averaging enabled (16 samples), $F_{in} = 10\text{KHz}$ <sup>(2)</sup>		11.8		bit
SNR	Signal-to-noise ratio	External reference <sup>(2)</sup>		67		dB
		Internal reference, $V_{R+} = VREF = 2.5\text{V}$		65		
SNR	Signal-to-noise ratio	External reference <sup>(2)</sup> , hardware averaging enabled (16 samples)		75		dB
		External reference <sup>(2)</sup> , $VDD = VDD_{(min)}$ to $VDD_{(max)}$		68		
PSRR <sub>DC</sub>	Power supply rejection ratio, DC	$VDD = VDD_{(min)}$ to $VDD_{(max)}$ Internal reference, $V_{R+} = VREF = 2.5\text{V}$		61		dB
		External reference <sup>(2)</sup> , $\Delta VDD = 0.1\text{V}$ at 1 kHz		61		
PSRR <sub>AC</sub>	Power supply rejection ratio, AC	$\Delta VDD = 0.1\text{V}$ at 1 kHz Internal reference, $V_{R+} = VREF = 2.5\text{V}$		49		dB
$T_{\text{wakeup}}$	ADC Wakeup Time	Assumes internal reference is active			5	us
$V_{\text{SupplyMon}}$	Supply Monitor voltage divider (VDD/3) accuracy	ADC input channel: Supply Monitor <sup>(3)</sup>	-1.5		+1.5	%
$I_{\text{SupplyMon}}$	Supply Monitor voltage divider current consumption	ADC input channel: Supply Monitor		10		uA

- (1) The analog input voltage range must be within the selected ADC reference voltage range  $V_{R+}$  to  $V_{R-}$  for valid conversion results.
- (2) All external reference specifications are measured with  $V_{R+} = VREF+ = VDD = 3.3\text{V}$  and  $V_{R-} = VREF- = VSS = 0\text{V}$  and external 1uF cap on VREF+ pin
- (3) Analog power supply monitor. Analog input on channel 31 is disconnected and is internally connected to the voltage divider which is VDD/3.

### 7.12.2 Linearity Parameters

over recommended ranges of supply voltage and operating free-air temperature (unless otherwise noted), all TYP values are measured at 25°C and all linearity parameters are measured using 12-bit resolution mode (unless otherwise noted) <sup>(1)</sup>

PARAMETER		TEST CONDITIONS	MIN	TYP	MAX	UNIT
E <sub>I</sub>	Integral linearity error (INL)	External reference <sup>(2)</sup>	-2.0		+2.0	LSB
E <sub>D</sub>	Differential linearity error (DNL) Ensured no missing codes	External reference <sup>(2)</sup>	-1.0		+1.0	LSB
E <sub>D</sub>	Differential linearity error (DNL) Ensured no missing codes	External reference <sup>(2)</sup> , HW Averaging Enabled, 16 Samples		1		
E <sub>O</sub>	Offset error	External reference <sup>(2)</sup>	-5		5	mV
E <sub>G</sub>	Gain error	External reference <sup>(2)</sup>	-6		6	LSB

(1) Total Unadjusted Error (TUE) can be calculated from E<sub>I</sub>, E<sub>O</sub>, and E<sub>G</sub> using the following formula:  $TUE = \sqrt{(E_I)^2 + |E_O|^2 + E_G^2}$   
Note: You must convert all of the errors into the same unit, usually LSB, for the above equation to be accurate

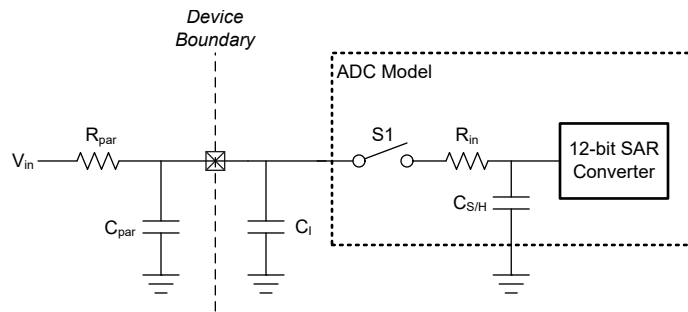
(2) All external reference specifications are measured with VR+ = VREF+ = VDD = 3.3V and VR- = VREF- = VSS = 0V and external 1uF cap on VREF+ pin

### 7.12.3 Switching Characteristics

over recommended ranges of supply voltage and operating free-air temperature (unless otherwise noted)

PARAMETER		TEST CONDITIONS	MIN	TYP	MAX	UNIT
f <sub>ADCCLK</sub>	ADC clock frequency		4		32	MHz
t <sub>ADC trigger</sub>	Software trigger minimum width		3			ADCCLK cycles
t <sub>Sample_step</sub>	Sampling time for step input	12-bit mode, R <sub>S</sub> = 50Ω, C <sub>pext</sub> = 10pF	0.188			μs
t <sub>Sample_VREF</sub>	Sample time with internal VREF input	ADC CHANNEL=29, 12-bit mode, VDD as reference	10			
t <sub>Sample_SupplyMon</sub>	Sample time with Supply Monitor (VDD/3)	12-bit mode	5			μs

### 7.12.4 Typical Connection Diagram



**Figure 7-2. ADC Input Network**

1. Refer to [Section 7.12.1](#) for the values of R<sub>in</sub> and C<sub>S/H</sub>
2. Refer to [Digital IO Electrical Characteristics](#) for the value of C<sub>I</sub>
3. C<sub>par</sub> and R<sub>par</sub> represent the parasitic capacitance and resistance of the external ADC input circuitry

Use the following equations to solve for the minimum sampling time (T) required for an ADC conversion:

1.  $\tau = (R_{par} + R_{in}) * C_{S/H} + R_{par} * (C_{par} + C_I)$
2.  $K = \ln(2^n / \text{Settling error}) - \ln((C_{par} + C_I) / C_{S/H})$
3.  $T (\text{Min sampling time}) = K * \tau$

## 7.13 Temperature Sensor

over operating free-air temperature range (unless otherwise noted)

PARAMETER		TEST CONDITIONS	MIN	TYP	MAX	UNIT
TS <sub>TRIM</sub>	Factory trim temperature <sup>(1)</sup>	ADC and VREF configuration: RES=0 (12-bit mode), VRSEL=2h (internal VREF), BUFCONFIG=1h (1.4V VREF), ADC t <sub>sample</sub> =10μs	27	30	33	°C
TS <sub>c</sub>	Temperature coefficient		-2.05	-1.9	-1.75	mV/°C
t <sub>SET, TS</sub>	Temperature sensor settling time <sup>(2)</sup>			2.5	10	us

- (1) Higher absolute accuracy may be achieved through user calibration.  
 (2) This is the maximum time required for the temperature sensor to settle when measured by the ADC. It may be used to specify the minimum ADC sample time when measuring the temperature sensor.

## 7.14 VREF

### 7.14.1 Electrical Characteristics

over recommended ranges of supply voltage and operating free-air temperature (unless otherwise noted)

PARAMETER		TEST CONDITIONS	MIN	TYP	MAX	UNIT
$I_{VREF}$	VREF operating supply current	BUFCONFIG = {0, 1}, No load		80	100	$\mu$ A
$TC_{VREF}$	Temperature coefficient of VREF <sup>(1)</sup>	BUFCONFIG = {0, 1}			75	ppm/°C
$TC_{drift}$	Long term VREF drift	Time = 1000 hours, BUFCONFIG = {0, 1}, T = 25°C			300	ppm
$PSRR_{DC}$	VREF Power supply rejection ratio, DC	VDD = 1.7V to VDDmax, BUFCONFIG = 1	60	70		dB
		VDD = 2.7V to VDDmax, BUFCONFIG = 0	49	60		
ADC $F_S$	Max supported ADC sampling frequency	Using VREF as ADC reference			515	ksps
$T_{startup}$	VREF startup time	BUFCONFIG = {0, 1}, VDD = 2.8 V			30	us

(1) The temperature coefficient of the VREF output is the sum of  $TC_{VRBUF}$  and the temperature coefficient of the internal bandgap reference.

### 7.14.2 Voltage Characteristics

over recommended ranges of supply voltage and operating free-air temperature (unless otherwise noted)

PARAMETER		TEST CONDITIONS	MIN	TYP	MAX	UNIT
$V_{DDmin}$	Minimum supply voltage needed for VREF operation	BUFCONFIG = 1	1.62			V
		BUFCONFIG = 0	2.7			
VREF	Voltage reference output voltage	BUFCONFIG = 1	1.38	1.4	1.42	V
		BUFCONFIG = 0	2.46	2.5	2.54	

## 7.15 Comparator (COMP)

### 7.15.1 Comparator Electrical Characteristics

over recommended ranges of supply voltage and operating free-air temperature (unless otherwise noted)

PARAMETER		TEST CONDITIONS	MIN	TYP	MAX	UNIT
<b>Comparator Electrical Characteristics</b>						
$V_{cm}$	Common mode input range		0		VDD	V
$V_{offset}$	Input offset voltage		-20		20	mV
$V_{hys}$	DC input hysteresis	HYST=00h		0.4		mV
		HYST=01h		10		
		HYST=02h		20		
		HYST=03h		30		
$t_{PD\_ls}$	Propagation delay, response time	Output Filter off, Overdrive = 100 mV, High Speed Mode		32	50	ns
		Output Filter off, Overdrive = 100 mV, Low Power Mode		1.2	4	$\mu$ s
$t_{en}$	Comparator enable time	Startup time to reach propagation delay specification, High Speed Mode			5	$\mu$ s
		Startup time to reach propagation delay specification, Low Power Mode			10	$\mu$ s
$I_{comp}$	Comparator current consumption.	Vcm = VDD/2, 100mV overdrive, DAC output as a voltage reference, VDD is reference for DAC, High Speed Mode		130	200	$\mu$ A
		Vcm = VDD/2, 100mV overdrive, DAC output as a voltage reference, VDD is reference for DAC, Low Power Mode		0.85	2.7	$\mu$ A
		Vcm = VDD/2, 100mV overdrive, comparator only, High Speed Mode		120	180	$\mu$ A
		Vcm = VDD/2, 100mV overdrive, comparator only, Low Power Mode		0.7	2.1	$\mu$ A

over recommended ranges of supply voltage and operating free-air temperature (unless otherwise noted)

PARAMETER		TEST CONDITIONS	MIN	TYP	MAX	UNIT
<b>8-bit DAC Electrical Characteristics</b>						
$V_{dac}$	DAC output range		0		VDD	V
$V_{dac-code}$	8-bit DAC output voltage for a given code	$V_{IN}$ = reference voltage into 8-bit DAC, code $n = 0$ to 255		$V_{IN} \times (n+1) / 256$		V
INL	Integral nonlinearity of 8-bit DAC		-1		1	LSB
DNL	Differential nonlinearity of 8-bit DAC		-1		1	LSB
Gain error	Gain error of 8-bit DAC	Reference voltage = VDD	-2		2	% of FSR
Offset error	Offset error of 8-bit DAC		-5		5	mV
Output Impedance	8-bit DAC output impedance			50		k $\Omega$
$t_{dac\_settle}$	8-bit DAC settling time in static mode	DACCODE0 = 0 $\rightarrow$ 255, DAC output accurate to 1 LSB, DAC output on pin PA11, Cload = 15pF		6		$\mu$ s
$t_{dac\_settle}$	8-bit DAC settling time in static mode	DACCODE0 = 0 $\rightarrow$ 255, DAC output accurate to 1 LSB		1.5		$\mu$ s

## 7.16 LCD

over operating free-air temperature range (unless otherwise noted)

PARAMETERS		TEST CONDITIONS	MIN	TYP	MAX	UNIT
<b>LCD Electrical Characteristics</b>						
$V_{CC, LCD, CP\ en, 3.6}$	Supply voltage range, charge pump enabled, $V_{LCD} \leq 3.6$ V	LCDCPEN = 1, $0000 < VLCDx \leq 1111$ , LCDREFEN = 1 (charge pump enabled, $VLCD \leq 3.6$ V)	1.62		3.6	V
Delta VLCD	1/4 bias mode	LCDCPEN = 1, $0000 < VLCDx \leq 1111$ , LCDREFEN = 1 (charge pump enabled, $VLCD \leq 3.6$ V)		60		mV
Delta VLCD	1/3 bias mode	LCDCPEN = 1, $0000 < VLCDx \leq 1111$ , LCDREFEN = 1 (charge pump enabled, $VLCD \leq 3.6$ V)		75		mV
$V_{CC, LCD, ext. bias}$	Supply voltage range, external biasing, charge pump enabled	LCDCPEN = 1, LCDREFEN = 0	1.62		3.6	V
$V_{CC, LCD, VLCDEXT}$	Supply voltage range, external LCD voltage, external biasing, charge pump disabled	LCDCPEN = 0, LCDSELVDD = 0	1.62		3.6	V
$V_{R33}$	External LCD voltage at R33, external biasing, charge pump disabled	LCDCPEN = 0, LCDSELVDD = 0	1.62		3.6	V
$V_{R33}$	LCD voltage at R33, internal biasing, charge pump enabled	LCDCPEN=1, LCDSELVDD=0, LCDREFEN=1	2.4		3.8	V
$C_{LDCAP}$		+/-20% tolerance is recommended, ceramic caps X5R (Between LDCAP0 and LDCAP1)		0.47		$\mu$ F
$C_{R33}$		+/-20% tolerance is recommended, ceramic caps X5R		0.47		$\mu$ F
$C_{R23}$		+/-20% tolerance is recommended, ceramic caps X5R		0.47		$\mu$ F
$C_{R24}$		+/-20% tolerance is recommended, ceramic caps X5R		0.47		$\mu$ F
$C_{R13}$		+/-20% tolerance is recommended, ceramic caps X5R		0.47		$\mu$ F
$f_{Frame}$	LCD frame frequency range	$f_{LCD} = 2 \times mux \times f_{FRAME}$ with $mux = 1$ (static), 2, 3, 4, 8	16	32	64	Hz
$f_{LFCLK, in}$	LFCLK input frequency range	+/-10% accurate		32.768		kHz
$C_{Panel}$	Panel capacitance	32-Hz frame frequency			20	nF

over operating free-air temperature range (unless otherwise noted)

PARAMETERS		TEST CONDITIONS	MIN	TYP	MAX	UNIT
V <sub>R33</sub>	Analog input voltage at R33	LCDCPEN = 0, LCDSELVDD = 0, LCDREFEN = 0	1.6		3.6	V
V <sub>R23, 1/3bias</sub>	Analog input voltage at R23 with 1/3 biasing	LCDCPEN = 0, LCDSELVDD = 0, LCDREFEN = 0	1.1		2.4	V
V <sub>R23, 1/4bias</sub>	Analog input voltage at R23 with 1/4 biasing	LCDCPEN = 0, LCDSELVDD = 0, LCDREFEN = 0	1.2		2.7	V
V <sub>R24, 1/4bias</sub>	Analog input voltage at R24 with 1/4 biasing	LCDCPEN = 0, LCDSELVDD = 0, LCDREFEN = 0	0.8		1.8	V
V <sub>R13, 1/3bias</sub>	Analog input voltage at R13 with 1/3 biasing	LCDCPEN = 0, LCDSELVDD = 0, LCDREFEN = 0	0		1.2	V
V <sub>R14, 1/4bias</sub>	Analog input voltage at R14 with 1/4 biasing	LCDCPEN = 0, LCDSELVDD = 0, LCDREFEN = 0	0		0.9	V
V <sub>LCDREF/R13</sub>	External LCD reference voltage applied at LCDREF/R13 for 1/4 bias mode	LCDCPEN = 1, LCDSELVDD = 0, LCDREFEN = 0	0.6		0.9	V
V <sub>LCDREF/R13</sub>	External LCD reference voltage applied at LCDREF/R13 for 1/3 bias mode	LCDCPEN = 1, LCDSELVDD = 0, LCDREFEN = 0	0.8		1.2	V
Tamb	Operating Temperature Range		-40	25	125	deg C
IDD LCD	Stand by power - External Biasing (Mode 0), Vboost = OFF. External resistor ladder. 5% matched tolerance and less than 1% individual tolerance	Vdd >= 2.4V, LCDCPEN = 0, LCDSELVDD = 0, LCDSEL_VDD_R33 = 0, LCDINTBIASEN = 0, LCDVREFEN = 0, Vboost = OFF, External Supply on		100		nA
IDD LCD	Stand by power - External Biasing (Mode 0), Vboost = ON, External resistor ladder. Current through resistor ladder is not accounted in spec. 5% matched tolerance and less than 1% individual tolerance	Vdd < 2.4V, LCDCPEN = 0, LCDSELVDD = 0, LCDSEL_VDD_R33 = 0, LCDINTBIASEN = 0, LCDVREFEN = 0, Vboost = ON, External Supply on		150		nA
IDD LCD	Stand by power - Internal Biasing (Mode 1). Enable VDD connection to R33 pin and add external resistor ladder. Current through resistor ladder is not accounted in spec	LCDCPEN = 0, LCDSELVDD = 1, LCDSEL_VDD_R33 = 0, LCDINTBIASEN = 0, LCDVREFEN = 0 (Internal reference disabled), Vboost = OFF, External Supply Off		54		uA
IDD LCD	Stand by power - External Biasing (Mode 2). Check for LCD_HP_LP = 0/1 and LCDBIASSEL = 0/1	LCDCPEN = 0, LCDSELVDD = 0, LCDSEL_VDD_R33 = 0, LCDINTBIASEN = 1, LCDVREFEN = 0 (Internal reference disabled), Vboost = OFF, External Supply on		100		nA
IDD LCD	Stand by power - Internal Biasing (Mode 3). Check for LCD_HP_LP = 0/1 and LCDBIASSEL = 0/1. AVDD connected to internal ladder used to generate voltages	LCDCPEN = 0, LCDSELVDD = 0, LCDSEL_VDD_R33 = 1, LCDINTBIASEN = 1, LCDVREFEN = 0 (Internal reference disabled), Vboost = OFF, External Supply off		57		uA
IDD LCD	Stand by power - External Biasing (Mode 4). Check for LCDBIASSEL = 0/1. Vext connected to R33. CP used to generate voltage fractions	LCDCPEN = 1, LCDSELVDD = 0, LCDSEL_VDD_R33 = 0, LCDINTBIASEN = 0, LCDVREFEN = 0 (Internal reference disabled), Vboost = OFF, External Supply on		200		nA
IDD LCD	Stand by power - Internal Biasing (Mode 5). Check for LCDBIASSEL = 0/1. AVDD connected to R33. CP used to generate voltage fractions. LOADCAP0/1 are connected	LCDCPEN = 1, LCDCPFSELx = 0x2, LCDSELVDD = 1, LCDSEL_VDD_R33 = 1, LCDINTBIASEN = 0, LCDVREFEN = 0 (Internal reference disabled), Vboost = OFF, External Supply off		300		nA

over operating free-air temperature range (unless otherwise noted)

PARAMETERS		TEST CONDITIONS	MIN	TYP	MAX	UNIT
IDD LCD	Stand by power - External Biasing (Mode 6). CP used to generate 1/3 and 1/4 voltage fractions. Vext connected to R13. LOADCAP0/1 are connected	LCDCPEN =1, LCDSELVDD=0, LCDSEL_VDD_R33=1, LCDINTBIASEN=0, LCDVREFEN =0( Internal reference disabled), Vboost= OFF, External Supply on		200		nA
IDD LCD	Stand by power - Internal Biasing (Mode 7). CP used to generate 1/3 and 1/4 voltage fractions. LOADCAP0/1 are connected. Vboost = OFF	LCDCPEN =1, LCDCPFSELx=0x2, VLCDx=3V LCDSELVDD=0, LCDSEL_VDD_R33=1, LCDINTBIASEN=0, LCDVREFEN =1( Internal reference enabled), LCDREFMODE =0/1		1.2		μA
IDD LCD	Stand by power - Internal Biasing (Mode 7). CP used to generate 1/3 and 1/4 voltage fractions. LOADCAP0/1 are connected. Vboost = ON	LCDCPEN =1, LCDCPFSELx=0x2, VLCDx=3V LCDSELVDD=0, LCDSEL_VDD_R33=1, LCDINTBIASEN=0, LCDVREFEN =1( Internal reference enabled), LCDREFMODE =0/1		1.5		μA

## 7.17 I2C

### 7.17.1 I2C Characteristics

over operating free-air temperature range (unless otherwise noted)

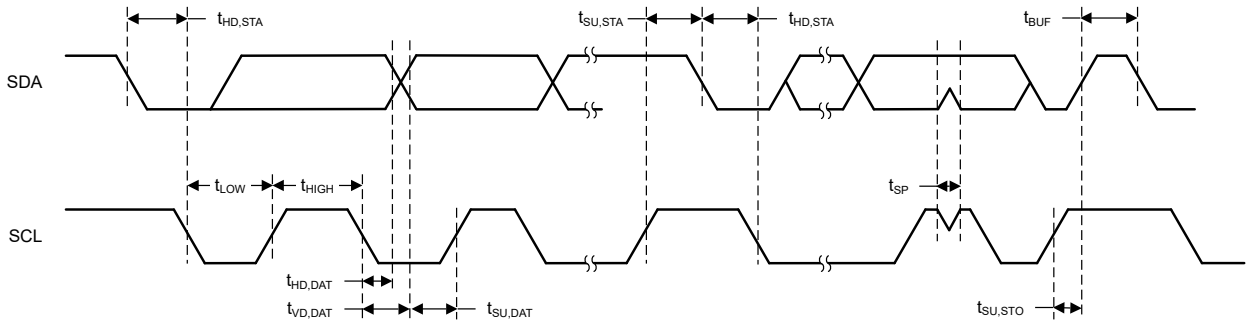
PARAMETERS		TEST CONDITIONS	Standard mode		Fast mode		Fast mode plus		UNIT
			MIN	MAX	MIN	MAX	MIN	MAX	
f <sub>I2C</sub>	I2C input clock frequency	I2C in Power Domain0	2	32	8	32	20	32	MHz
f <sub>SCL</sub>	SCL clock frequency			0.1		0.4		1	MHz
t <sub>HD,STA</sub>	Hold time (repeated) START		4		0.6		0.26		us
t <sub>LOW</sub>	Low period of the SCL clock		4.7		1.3		0.5		us
t <sub>HIGH</sub>	High period of the SCL clock		4		0.6		0.26		us
t <sub>SU,STA</sub>	Setup time for a repeated START		4.7		0.6		0.26		us
t <sub>HD,DAT</sub>	Data hold time		0		0		0		ns
t <sub>SU,DAT</sub>	Data setup time		250		100		50		ns
t <sub>SU,STO</sub>	Setup time for STOP		4		0.6		0.26		us
t <sub>BUF</sub>	Bus free time between a STOP and START condition		4.7		1.3		0.5		us
t <sub>VD,DAT</sub>	Data valid time			3.45		0.9		0.45	us
t <sub>VD,ACK</sub>	Data valid acknowledge time			3.45		0.9		0.45	us

### 7.17.2 I2C Filter

over operating free-air temperature range (unless otherwise noted)

PARAMETERS		TEST CONDITIONS	MIN	TYP	MAX	UNIT
f <sub>SP</sub>	Pulse duration of spikes suppressed by input filter	AGFSELx = 0		6		ns
		AGFSELx = 1		14	35	ns
		AGFSELx = 2		22	60	ns
		AGFSELx = 3		35	90	ns

### 7.17.3 I<sup>2</sup>C Timing Diagram



**Figure 7-3. I2C Timing Diagram**

## 7.18 SPI

### 7.18.1 SPI

over operating free-air temperature range (unless otherwise noted)

PARAMETERS		TEST CONDITIONS	MIN	TYP	MAX	UNIT
<b>SPI</b>						
f <sub>SPI</sub>	SPI clock frequency	Clock max speed = 32MHz 1.62 < VDD < 3.6V Controller mode			16	MHz
f <sub>SPI</sub>	SPI clock frequency	Clock max speed = 32MHz 1.62 < VDD < 3.6V Peripheral mode			16	MHz
DC <sub>SCK</sub>	SCK Duty Cycle		40	50	60	%
<b>Controller</b>						
t <sub>SCLK_H/L</sub>	SCLK High or Low time		(t <sub>SPI</sub> /2) - 1	t <sub>SPI</sub> / 2	(t <sub>SPI</sub> /2) + 1	ns
t <sub>CS.LEAD</sub>	CS lead-time, CS active to clock	SPH=0	1 SPI Clock			ns
t <sub>CS.LEAD</sub>	CS lead-time, CS active to clock	SPH=1	1/2 SPI Clock			ns
t <sub>CS.LAG</sub>	CS lag time, Last clock to CS inactive	SPH=0	1/2 SPI Clock			ns
t <sub>CS.LAG</sub>	CS lag time, Last clock to CS inactive	SPH=1	1 SPI Clock			ns
t <sub>CS.ACC</sub>	CS access time, CS active to PICO data out			1/2 SPI Clock		ns
t <sub>CS.DIS</sub>	CS disable time, CS inactive to PICO high impedance			1 SPI Clock		ns
t <sub>SU.CI</sub>	POCI input data setup time <sup>(1)</sup>	2.7 < VDD < 3.6V, delayed sampling enabled	1			ns
		1.62 < VDD < 2.7V, delayed sampling enabled	8			
t <sub>SU.CI</sub>	POCI input data setup time <sup>(1)</sup>	2.7 < VDD < 3.6V, no delayed sampling	30			ns
		1.62 < VDD < 2.7V, no delayed sampling	39			
t <sub>HD.CI</sub>	POCI input data hold time		0			
t <sub>VALID.CO</sub>	PICO output data valid time <sup>(2)</sup>				16	ns
t <sub>HD.CO</sub>	PICO output data hold time <sup>(3)</sup>		1			ns
<b>Peripheral</b>						
t <sub>CS.LEAD</sub>	CS lead-time, CS active to clock		13.5			ns

over operating free-air temperature range (unless otherwise noted)

PARAMETERS		TEST CONDITIONS	MIN	TYP	MAX	UNIT
$t_{CS,LAG}$	CS lag time, Last clock to CS inactive		1			ns
$t_{CS,ACC}$	CS access time, CS active to POCI data out				41	ns
$t_{CS,DIS}$	CS disable time, CS inactive to POCI high impedance				41	ns
$t_{SU,PI}$	PICO input data setup time		15			ns
$t_{HD,PI}$	PICO input data hold time		2.9			ns
$t_{VALID,PO}$	POCI output data valid time <sup>(2)</sup>	$2.7 < VDD < 3.6V$			31	ns
$t_{VALID,PO}$	POCI output data valid time <sup>(2)</sup>	$1.62 < VDD < 2.7V$			41	ns
$t_{HD,PO}$	POCI output data hold time <sup>(3)</sup>		5.5			ns

- (1) The POCI input data setup time can be fully compensated when delayed sampling feature is enabled.
- (2) Specifies the time to drive the next valid data to the output after the output changing SCLK clock edge
- (3) Specifies how long data on the output is valid after the output changing SCLK clock edge

### 7.18.2 SPI Timing Diagram

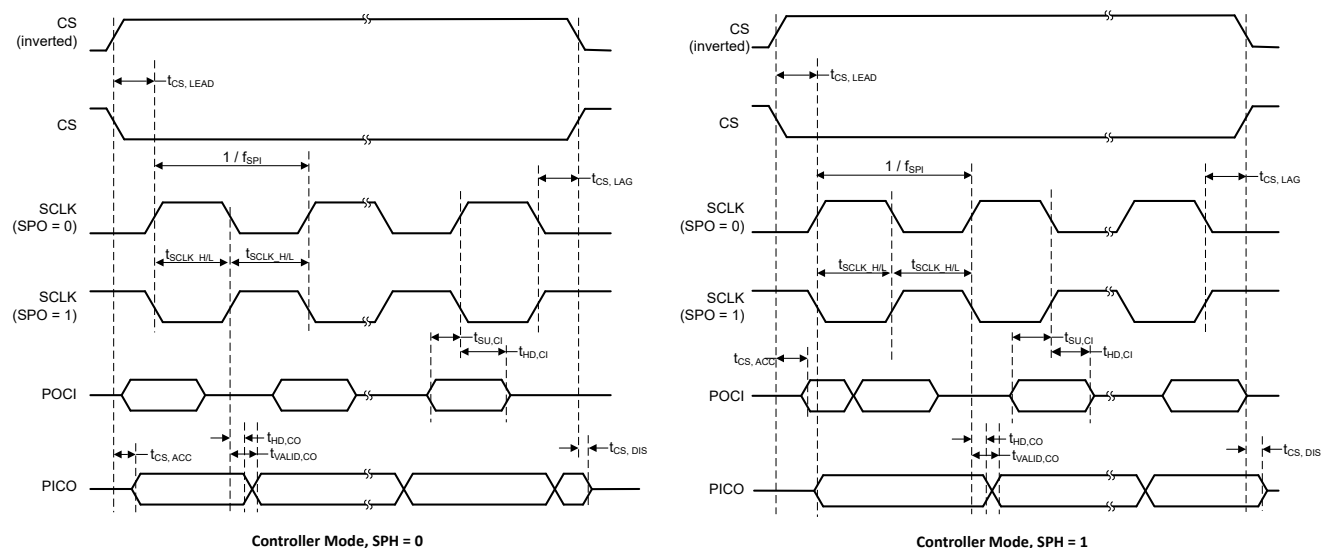
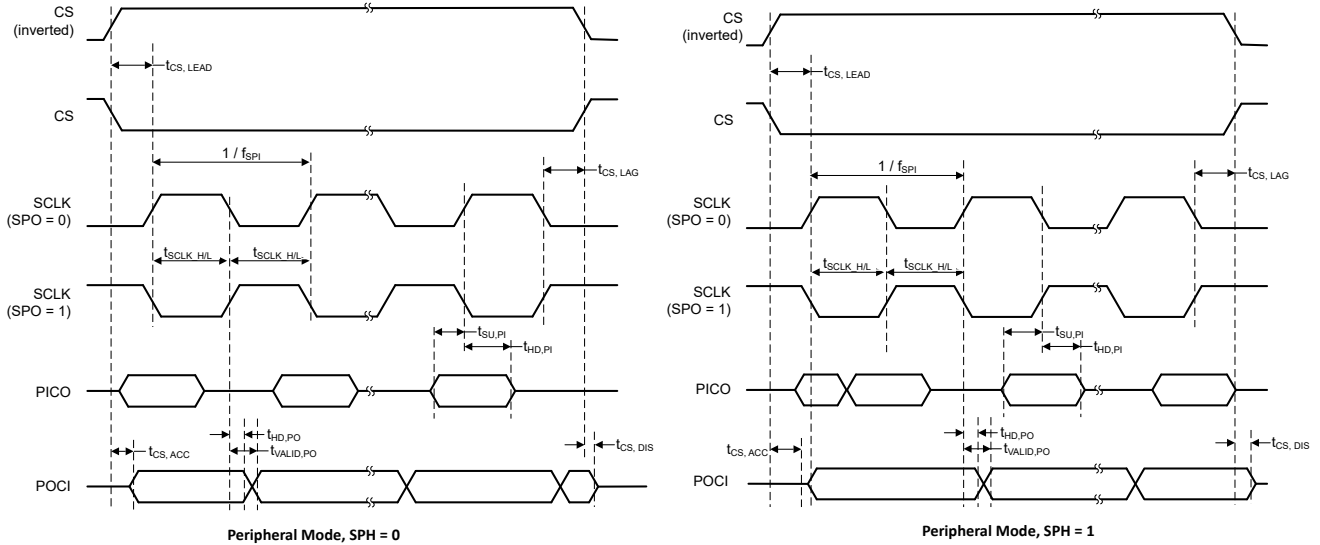


Figure 7-4. SPI Timing Diagram - Controller Mode



**Figure 7-5. SPI Timing Diagram - Peripheral Mode**

### 7.19 UART

over operating free-air temperature range (unless otherwise noted)

PARAMETERS		TEST CONDITIONS	MIN	TYP	MAX	UNIT
$f_{UART}$	UART input clock frequency				32	MHz
$f_{BITCLK}$	BITCLK clock frequency (equals baud rate in MBaud)				4	MHz
$t_{SP}$	Pulse duration of spikes suppressed by input filter	AGFSELx = 0		6		ns
		AGFSELx = 1		14	35	ns
		AGFSELx = 2		22	60	ns
		AGFSELx = 3		35	90	ns

### 7.20 TIMx

over operating free-air temperature range (unless otherwise noted)

PARAMETERS		TEST CONDITIONS	MIN	TYP	MAX	UNIT
$t_{res}$	Timer resolution time	$f_{TIMxCLK} = 32MHz$	31.25			ns
			1			$t_{TIMxCLK}$
$t_{res}$	Timer resolution time	TIMx with 16bit counter			16	bit
$t_{COUNTER}$	16-bit counter clock period	$f_{TIMxCLK} = 32MHz$	0.03125		2048	us
			1		65536	$t_{TIMxCLK}$

### 7.21 Emulation and Debug

#### 7.21.1 SWD Timing

over operating free-air temperature range (unless otherwise noted)

PARAMETER		TEST CONDITIONS	MIN	TYP	MAX	UNIT
$f_{SWD}$	SWD frequency				10	MHz

## 8 Detailed Description

The following sections describe all of the components that make up the devices in this data sheet. The peripherals integrated into these devices are configured by software through Memory Mapped Registers (MMRs). For more details, see the corresponding chapter of the [MSPM0 L-Series 32MHz Microcontrollers Technical Reference Manual](#).

### 8.1 CPU

The CPU subsystem (MCPUSS) implements an Arm Cortex-M0+ CPU, an instruction pre-fetch/cache, a system timer, and interrupt management features. The Arm Cortex-M0+ is a cost-optimized, 32-bit CPU which delivers high performance and low power to embedded applications. Key features of the CPU Sub System include:

- Arm Cortex-M0+ CPU supporting clock frequencies up to 32kHz
  - ARMv6-M Thumb instruction set (little endian) with 32-cycle 32x32 multiply instruction
- Pre-fetch logic to improve sequential code execution, and I-cache with two 64-bit cache lines
- System timer (SysTick) with 24-bit down counter and automatic reload
- Nested vectored interrupt controller (NVIC) with 4 programmable priority levels and tail-chaining

For more details, see the CPU chapter of the [MSPM0 L-Series 32MHz Microcontrollers Technical Reference Manual](#).

### 8.2 Operating Modes

MSPM0 MCUs provide five main operating modes (power modes) to allow for optimization of the device power consumption based on application requirements. In order of decreasing power, the modes are: RUN, SLEEP, STOP, STANDBY, and SHUTDOWN. The CPU is active executing code in RUN mode. Peripheral interrupt events can wake the device from SLEEP, STOP, or STANDBY mode to the RUN mode. SHUTDOWN mode completely disables the internal core regulator to minimize power consumption, and wake is only possible via NRST, SWD, or a logic level match on certain IOs. RUN, SLEEP, STOP, and STANDBY modes also include several configurable policy options (for example, RUN.x) for balancing performance with power consumption.

To further balance performance and power consumption, MSPM0 devices implement two power domains: **PD1** (for the CPU, memories, and high performance peripherals), and **PD0** (for low speed, low power peripherals).

- **PD1** is always powered in RUN and SLEEP modes, but is disabled in all other modes.
- **PD0** is always powered in RUN, SLEEP, STOP, and STANDBY modes.
- **PD1** and **PD0** are both disabled in SHUTDOWN mode.

#### 8.2.1 Functionality by Operating Mode

Supported functionality in each operating mode is given in [Table 8-1](#).

Functional key:

- **EN**: The function is enabled in the specified mode.
- **DIS**: The function is disabled (either clock or power gated) in the specified mode, but the function's configuration is retained.
- **OPT**: The function is optional in the specified mode, and remains enabled if configured to be enabled.
- **NS**: The function is not automatically disabled in the specified mode but is not supported.
- **OFF**: The function is fully powered off in the specified mode, and no configuration information is retained. When waking up from an OFF state, all module registers must be re-configured to the desired settings by application software.

**Table 8-1. Supported Functionality by Operating Mode**

Operating Mode		RUN			SLEEP			STOP		STANDBY		SHUT DOWN	
		RUN0	RUN1	RUN2	SLEEP0	SLEEP1	SLEEP2	STOP0	STOP2	STANDBY0	STANDBY1		
Oscillators	SYSSOSC	EN	EN	DIS	EN	EN	DIS	OPT <sup>(1)</sup>	DIS	DIS	DIS	OFF	
	LFOSC or LFXT	EN										OFF	
	HFXT	EN	DIS	DIS	OPT	DIS						OFF	
Clocks	CPUCLK	32M	32k	32k	DIS							OFF	
	MCLK to PD1	32M	32k	32k	32M	32k	32k	DIS				OFF	
	ULPCLK to PD0	32M	32k	32k	32M	32k	32k	4M	32k	DIS	DIS	OFF	
	ULPCLK to TIMG14, TIMB0, TIMB1, TIMB2, TIMB3	32M	32k	32k	32M	32k	32k	4M	32k			OFF	
	RTCCLK	32k										OFF	
	MFCLK	OPT	DIS		OPT	DIS		OPT	DIS			OFF	
	LFCLK	32k									DIS	OFF	
	LFCLK to TIMG14, TIMB0, TIMB1, TIMB2, TIMB3	32k										OFF	
	MCLK Monitor	OPT									DIS	OFF	
	LFCLK Monitor	OPT										OFF	
PMU	POR Monitor	EN											
	BOR Monitor	EN										OFF	
	Core Regulator	Full drive							Low drive			OFF	
Core Functions	CPU	EN			DIS							OFF	
	DMA	OPT					NS (triggers supported)					OFF	
	Flash	EN					OPT		DIS			OFF	
	SRAM	EN					OPT		DIS			OFF	
PD1 Peripherals	CRC	OPT					DIS					OFF	
	TIMA0	OPT					DIS					OFF	
	UC8	OPT					DIS					OFF	
	UC11	OPT					DIS					OFF	
	AESADV	OPT					DIS					OFF	
	TRNG	OPT					OFF					OFF	
PD0 Peripherals	TIMG14						OPT					OPT <sup>(2)</sup>	OFF
	TIMG1						OPT					OPT <sup>(2)</sup>	OFF
	TIMG2						OPT					OPT <sup>(2)</sup>	OFF
	UC4						OPT					OPT <sup>(2)</sup>	OFF
	UC6						OPT					OPT <sup>(2)</sup>	OFF
	UC7						OPT					OPT <sup>(2)</sup>	OFF
	GPIOA						OPT					OPT <sup>(2)</sup>	OFF
	GPIOB						OPT					OPT <sup>(2)</sup>	OFF
	LCD						OPT					OPT <sup>(2)</sup>	OFF
	WWDT0						OPT					DIS	OFF
Keystore	OPT										OFF		

**Table 8-1. Supported Functionality by Operating Mode (continued)**

Operating Mode		RUN			SLEEP			STOP		STANDBY		SHUT DOWN
		RUN0	RUN1	RUN2	SLEEP0	SLEEP1	SLEEP2	STOP0	STOP2	STANDBY0	STANDBY1	
LFSS Peripherals	IWDT	OPT										OFF
	RTC_B	OPT										OFF
Analog	ADC0	OPT						NS (triggers supported)				OFF
	VREF	OPT						NS				OFF
	COMP0	OPT										OFF
	Temperature Sensor	OTP								OFF		OFF
IOMUX and IO Wakeup		EN										DIS w/ WAKE
Wake Sources		N/A			ANY IRQ			PD0 IRQ				IOMUX , NRST, SWD

- (1) If STOP0 is entered from RUN1 (SYSOSC enabled but MCLK sourced from LFCLK), SYSOSC remains enabled as it was in RUN1, and ULPClk remains at 32kHz as it was in RUN1. If STOP0 is entered from RUN2 (SYSOSC was disabled and MCLK was sourced from LFCLK), SYSOSC remains disabled as it was in RUN2, and ULPClk remains at 32kHz as it was in RUN2.
- (2) When using the STANDBY1 policy for STANDBY, only TIMG14 and TIMB0/1/2/3 are clocked. Other PD0 peripherals can generate an asynchronous fast clock request upon external activity but are not actively clocked.

### 8.3 Power Management Unit (PMU)

The power management unit (PMU) generates the internally regulated core supplies for the device and provides supervision of the external supply (VDD). The PMU also contains the bandgap voltage reference used by the PMU itself as well as analog peripherals. Key features of the PMU include:

- Power-on reset (POR) supply monitor
- Brown-out reset (BOR) supply monitor with early warning capability using three programmable thresholds
- Core regulator with support for RUN, SLEEP, STOP, and STANDBY mode to dynamically balance performance with power consumption
- Parity-protected trim to immediately generate a power-on reset (POR) in the event that a power management trim is corrupted
- 4 bytes of shutdown memory

For more details, see the PMU chapter of the [MSPM0 L-Series 32MHz Microcontrollers Technical Reference Manual](#).

### 8.4 Clock Module (CKM)

The clock module provides the following oscillators:

- **LFOSC**: Internal low-frequency oscillator (32kHz)
- **SYSOSC**: Internal high-frequency oscillator (32MHz with factory trim)
- **LFXT/LFCKIN** : low-frequency external crystal oscillator or digital clock input (32kHz)
- **HFXT/HFCKIN**: high-frequency external crystal oscillator or digital clock input (4MHz to 32MHz)

The following clocks are distributed by the clock module for use by the processor, bus, and peripherals:

- **MCLK**: Main system clock for PD1 peripherals, derived from SYSOSC, LFCLK, or HSCLK, active in RUN and SLEEP modes
- **CPULCK**: Clock for the processor (derived from MCLK), active in RUN mode
- **ULPClk**: Ultra-low power clock for PD0 peripherals, active in RUN, SLEEP, STOP, and STANDBY modes
- **MFCLK**: 4MHz fixed mid-frequency clock for peripherals, available in RUN, SLEEP, and STOP modes

- **LFCLK:** 32kHz fixed low-frequency clock for peripherals or MCLK, active in RUN, SLEEP, STOP, and STANDBY modes
- **ADCCLK:** ADC clock, available in RUN, SLEEP and STOP modes
- **RTCCLK:** fixed 32kHz clock direct to RTC
- **CLK\_OUT:** Used to output a clock externally, available in RUN, SLEEP, STOP, and STANDBY modes
- **HFCLK:** High frequency clock derived from HFXT or HFCLK\_IN, available in RUN and SLEEP mode
- **HSCLK:** High speed clock derived from HFCLK, available in RUN and SLEEP mode

For more details, see the CKM chapter of the [MSPM0 L-Series 32MHz Microcontrollers Technical Reference Manual](#).

## 8.5 DMA Trigger Mapping

The direct memory access (DMA) controller allows movement of data from one memory address to another without CPU intervention. For example, the DMA can be used to move data from ADC conversion memory to SRAM. The DMA reduces system power consumption by allowing the CPU to remain in low power mode, without having to awaken to move data to or from a peripheral.

The DMA in these devices support the following key features:

- 3 DMA transfer channel
  - 2 full-feature channels, supporting repeated transfer modes
  - 1 basic channel, supporting single transfer mode
- Configurable DMA channel priorities
- Direct peripheral to DMA trigger is supported from ADC, UART, SPI or timer triggers.
- Byte (8-bit), short word (16-bit) and word (32-bit) or mixed byte and word transfer capability
- Transfer counter block size supports up to 64k transfers of any data type
- Configurable DMA transfer trigger selection
- Active channel interruption to service other channels
- Early interrupt generation for ping-pong buffer architecture
- Cascading channels upon completion of activity on another channel
- Stride mode to support data re-organization, such as 3-phase metering applications
- Gather mode

[Table 8-2](#) shows the DMA features that are supported and the corresponding DMA channel numbers.

**Table 8-2. DMA\_B Channel Features**

DMA Feature	DMA_B	
	Full-Feature Channel	Basic Channel
Channel Number	0	1, 2
Repeated mode	✓	–
Table & fill mode	✓	–
Gather mode	✓	–
Early IRQ notification	✓	–
Auto enable	✓	✓
Long long (128-bit) transfer	✓	✓
Stride mode	✓	✓
Cascading channel support	✓	✓

[Table 8-3](#) lists the available triggers for the DMA which are configured using the DMATCTL.DMATSEL control bits in the DMA memory mapped registers.

**Table 8-3. DMA Trigger Mapping**

DMACTL.DMATSEL	TRIGGER SOURCE
0	Software
1	Generic Subscriber 0 (FSUB_0)

**Table 8-3. DMA Trigger Mapping (continued)**

DMACTL.DMATSEL	TRIGGER SOURCE
2	Generic Subscriber 0 (FSUB_1)
3	AESADV PUBLISHER 1
4	AESADV PUBLISHER 2
5	UC4.PUBLISHER_1
6	UC4.PUBLISHER_2
7	UC6.PUBLISHER_1
8	UC6.PUBLISHER_2
9	UC7.PUBLISHER_1
10	UC7.PUBLISHER_2
11	UC8.PUBLISHER_1
12	UC8.PUBLISHER_2
13	ADC0 DMA Trigger

For more details, see the DMA chapter of the [MSPM0 L-Series 32MHz Microcontrollers Technical Reference Manual](#).

## 8.6 Events

The event manager transfers digital events from one entity (for example, a peripheral) to another (for example, a second peripheral, the DMA, or the CPU). The event manager implements event transfer through a defined set of event publishers (generators) and subscribers (receivers) which are interconnected through an event fabric containing a combination of static and programmable routes.

Events which are transferred by the event manager include:

- Peripheral event transferred to the CPU as an interrupt request (IRQ) (Static Event)
  - Example: RTC interrupt is sent to the CPU
- Peripheral event transferred to the DMA as a DMA trigger (DMA Event)
  - Example: UART data receive trigger to DMA to request a DMA transfer
- Peripheral event transferred to another peripheral to directly trigger an action in hardware (Generic Event)
  - Example: TIMx timer peripheral publishes a periodic event to the ADC subscriber port, and the ADC uses the event to trigger start-of-sampling

For more details, see the EVENT chapter of the [MSPM0 L-Series 32MHz Microcontrollers Technical Reference Manual](#).

**Table 8-4. Generic Event Channels**

A generic route is either a point-to-point (1:1) route or a point-to-two (1:2) splitter route in which the peripheral publishing the event is configured to use one of several available generic route channels to publish its event to another entity (or entities, in the case of a splitter route), where an entity may be another peripheral, a generic DMA trigger event, or a generic CPU event.

CHANID	Generic Route Channel Selection	Channel Type
0	No generic event channel selected	N/A
1	Generic event channel 1 selected	1 : 1
2	Generic event channel 2 selected	1 : 1
3	Generic event channel 3 selected	1 : 1
4	Generic event channel 4 selected	1 : 1
5	Generic event channel 5 selected	1 : 1
6	Generic event channel 6 selected	1 : 1
7	Generic event channel 7 selected	1 : 1
8	Generic event channel 8 selected	1 : 1
9	Generic event channel 9 selected	1 : 1

**Table 8-4. Generic Event Channels (continued)**

A generic route is either a point-to-point (1:1) route or a point-to-two (1:2) splitter route in which the peripheral publishing the event is configured to use one of several available generic route channels to publish its event to another entity (or entities, in the case of a splitter route), where an entity may be another peripheral, a generic DMA trigger event, or a generic CPU event.

CHANID	Generic Route Channel Selection	Channel Type
10	Generic event channel 10 selected	1 : 1
11	Generic event channel 11 selected	1 : 1
12	Generic event channel 12 selected	1 : 2 (splitter)
13	Generic event channel 13 selected	1 : 2 (splitter)
14	Generic event channel 14 selected	1 : 2 (splitter)
15	Generic event channel 15 selected	1 : 2 (splitter)

## 8.7 Memory

### 8.7.1 Memory Organization

Table 8-5 summarizes the memory map of the devices. For more information about the memory region detail, see the *Platform Memory Map* section in the [MSPM0 L-Series 32MHz Microcontrollers Technical Reference Manual](#).

**Table 8-5. Memory Organization Summary**

Memory Region	Subregion	MSPM0L2117, MSPM0L1127	MSPM0L2116, MSPM0L1126
Code (Flash Bank 0)	FLASH Main ECC Corrected	128KB 0x00000000 to 0x0001FFFF	64KB 0x00000000 to 0x0000FFFF
Code (Flash Bank 0)	FLASH Main ECC Uncorrected	128KB 0x00400000 to 0x0041FFFF	64KB 0x00400000 to 0x0040FFFF
SRAM (SRAM)	SRAM Default	12KB 0x20000000 to 0x20002FFF	12KB 0x20000000 to 0x20002FFF
SRAM (SRAM)	SRAM Parity Checked	12KB 0x20100000 to 0x20102FFF	12KB 0x20100000 to 0x20102FFF
SRAM (SRAM)	SRAM Unchecked	12KB 0x20200000 to 0x20202FFF	12KB 0x20200000 to 0x20202FFF
SRAM (SRAM)	SRAM Parity ECC Code	12KB 0x20300000 to 0x20302FFF	12KB 0x20300000 to 0x20302FFF
Code (Flash Bank 0)	FLASH Main ECC Code	128KB 0x41800000 to 0x4181FFFF	64KB 0x41800000 to 0x4180FFFF
Peripheral	NVM (NONMAIN)	0x41C00000 to 0x41C007FF	0x41C00000 to 0x41C007FF
Peripheral	FACTORY	0x41C40000 to 0x41C403FF	0x41C40000 to 0x41C403FF

### 8.7.2 Peripherals Summary

**Table 8-6. Peripherals Summary**

Peripheral name	Base Address	Size
ADC0	0x40004000	0x00002000
COMP0	0x40008000	0x00001F00
VREF	0x40030000	0x00001F00
LCD	0x40070000	0x00001F00
WWDT0	0x40080000	0x00001500
TIMG14	0x40084000	0x00001F00
TIMG1	0x40086000	0x00001F00
TIMG2	0x40088000	0x00001F00
LFSS	0x40094000	0x00001600
GPIOA	0x400A0000	0x00001F00

**Table 8-6. Peripherals Summary (continued)**

Peripheral name	Base Address	Size
GPIOB	0x400A2000	0x00001F00
KEYSTORECTL	0x400AC000	0x00002000
SYSCTL	0x400AF000	0x00003100
TIMB0	0x400B8000	0x00001C00
TIMB1	0x400BA000	0x00001C00
TIMB2	0x400BC000	0x00001C00
TIMB3	0x400BE000	0x00001C00
DEBUGSS	0x400C7000	0x00001F00
EVENTLP	0x400C9000	0x00003000
FLASHCTL	0x400CD000	0x00002000
CPUSS	0x40400000	0x00001F00
WUC	0x40424000	0x00000500
IOMUX	0x40428000	0x00002000
DMA	0x4042A000	0x00001F00
CRC0	0x40440000	0x00002000
AESADV	0x40442000	0x00001200
ADC0_SVT	0x4055A000	0x00001000
TIMA0	0x40860000	0x00001F00
UC4_UART	0x40A00000	0x00001500
UC6_I2CC	0x40A22000	0x00023500
UC7_I2CT	0x40A44000	0x00045500
UC4_SPI	0x40A60000	0x00061200
UC4	0x40A80000	0x00081C00
UC6	0x40A82000	0x00082A00
UC7	0x40A84000	0x00084A00
SPG0	0x40A9F000	0x000A0C00
UC8_UART	0x40B00000	0x00001500
UC11_UART	0x40B02000	0x00003500
UC8_SPI	0x40B60000	0x00061200
UC8	0x40B80000	0x00081C00
UC11	0x40B82000	0x00082A00

### 8.7.3 Interrupt Vector Number

**Table 8-7. Interrupt Vector Number**

Peripheral name	NVIC IRQ
SYSCTL	0
DEBUGSS	1
UC6	3
ADC0	4
TIMB0	5
TIMB1	6
COMP0	7
UC7	8
UC8	9
TIMB2	13

**Table 8-7. Interrupt Vector Number (continued)**

Peripheral name	NVIC IRQ
TIMB3	14
UC4	15
TIMG14	16
TIMG2	17
TIMA0	18
TIMG1	19
GPIOA	22
GPIOB	23
UC11	24
AESADV	26
FLASHCTL	27
LCD	28
WWDT0	29
LFSS	30
DMA	31

## 8.8 Flash Memory

A single bank of nonvolatile flash memory is provided for storing executable program code and application data.

Key features of the flash include:

- Hardware ECC protection (encode and decode) with single bit error correction and double-bit error detection
- In-circuit program and erase operations supported across the entire recommended supply range
- Small 1KB sector sizes (minimum erase resolution of 1KB)
- Up to 100,000 program/erase cycles on 32 selected sectors of the flash memory, with up to 10,000 program/erase cycles on the remaining flash memory (devices with 32kB support 100,000 cycles on the entire flash memory)

For more details, see the NVM chapter of the [MSPM0 L-Series 32MHz Microcontrollers Technical Reference Manual](#).

## 8.9 SRAM

MSPM0Lxx MCUs include a low-power high-performance SRAM memory with zero wait state access across the supported CPU frequency range of the device. MSPM0Lxx MCUs also provide up to 128KB of ECC protected SRAM with hardware parity. SRAM memory can be used for storing volatile information such as the call stack, heap, global data, and code. The SRAM memory content is fully retained in RUN, SLEEP, STOP, and STANDBY operating modes and is lost in SHUTDOWN mode. A write protection mechanism is provided to allow the application to dynamically write protect the SRAM memory with 1KB resolution. Write protection is useful when placing executable code into SRAM to provide a level of protection against unintentional overwrites of code by either the CPU or DMA. Placing code in SRAM can improve performance of critical loops by enabling zero wait state operation and lower power consumption.

## 8.10 GPIO

The general purpose input/output (GPIO) peripheral lets the application write data out and read data in through the device pins. Through the use of the Port A and Port B GPIO peripheral, these devices support up to 60 GPIO pins.

The key features of the GPIO module include:

- Set/Clear/Toggle multiple bits without the need of a read-modify-write construct in software
- GPIOs with "Standard with Wake" drive functionality able to wake the device from SHUTDOWN mode

- "FastWake" feature enables low-power wakeup from STOP and STANDBY modes for any GPIO port
- User controlled input filtering

For more details, see the GPIO chapter of the [MSPM0 L-Series 32MHz Microcontrollers Technical Reference Manual](#).

### 8.11 IOMUX

The IOMUX peripheral enables IO pad configuration and controls digital data flow to and from the device pins. The key features of the IOMUX include:

- IO Pad configuration registers allow for programmable drive strength, speed, pullup-down, and more
- Digital pin muxing allows for multiple peripheral signals to be routed to the same IO pad
- Pin functions and capabilities are user-configured using the PINCM register

For more details, see the IOMUX chapter of the [MSPM0 L-Series 32MHz Microcontrollers Technical Reference Manual](#).

### 8.12 ADC

The 12-bit analog-to-digital converter (ADC) module in these devices support fast 12-bit conversions with single-ended inputs.

ADC features include:

- 12-bit output resolution at up to 1.6-Msps with 10.6-bit ENOB
- Up to 26 external input channels
- Internal channels for temperature sensing, supply monitoring, and analog signal chain
- Software selectable reference:
  - Configurable internal dedicated ADC reference voltage of 1.4V or 2.5V (VREF)
  - MCU supply voltage (VDD)
  - Support for bringing in an external reference on VREF+/- device pins
  - Requires a decoupling capacitor placed on VREF+/- pins for proper operation.
- Operates in RUN, SLEEP, and STOP modes and supports triggers from STANDBY mode

**Table 8-8. ADC0 Channel Mapping**

CHANNEL[0:7]	SIGNAL NAME	CHANNEL[8:15]	SIGNAL NAME
0	A0	16	A16
1	A1	17	A17
2	A2	18	A18
3	A3	19	A19
4	A4	20	A20
5	A5	21	A21
6	A6	22	A22
7	A7	23	A23
8	A8	24	A24
9	A9	25	A25
10	A10	26	-
11	A11	27	Reserved
12	A12	28	Temperature Sensor
13	A13	29	VREFINT
14	A14	30	Reserved

**Table 8-8. ADC0 Channel Mapping (continued)**

CHANNEL[0:7]	SIGNAL NAME	CHANNEL[8:15]	SIGNAL NAME
15	A15	31	<i>Supply/Battery Monitor</i>

*Italicized* signal names are internal to the SoC. These signals are used for internal peripheral interconnections.

For more details, see the ADC chapter of the [MSPM0 L-Series 32MHz Microcontrollers Technical Reference Manual](#).

### 8.13 Temperature Sensor

The temperature sensor provides a voltage output that changes linearly with device temperature. The temperature sensor output is internally connected to one of ADC input channels to enable a temperature-to-digital conversion.

A unit-specific single-point calibration value for the temperature sensor is provided in the factory constants memory region. This calibration value represents the ADC conversion result (in ADC code format) corresponding to the temperature sensor being measured in 12-bit mode with the 1.4V internal VREF at the factory trim temperature ( $TS_{TRIM}$ ). This calibration value can be used with the temperature sensor temperature coefficient ( $TS_C$ ) to estimate the device temperature. See the temperature sensor section of the [MSPM0 L-Series 32MHz Microcontrollers Technical Reference Manual](#) for guidance on estimating the device temperature with the factory trim value.

### 8.14 LFSS

The Low-Frequency Subsystem (LFSS) combines several functional peripherals under one shared subsystem. These peripherals are clocked by the low-frequency clock (LFCLK) or need to be active during low-power modes. The low-frequency clock has a typical frequency of 32kHz and is mainly intended for long-term timekeeping.

LFSS in this device contains following components:

- [Real-time clock \(RTC\\_B\)](#) with additional prescaler extension and timestamp captures
- An asynchronous [Independent Watchdog Timer \(IWDT\)](#)

For more details, see the LFSS chapter of the [MSPM0 L-Series 32MHz Microcontrollers Technical Reference Manual](#).

### 8.15 IWDT

The independent watchdog timer (IWDT) in the LFSS is a device-independent supervisor which monitors code execution and overall hang up scenarios of the device. Due to the nature of LFSS, this IWDT has its own system independent clock source. If the application software does not successfully reset the watchdog within the programmed time, the watchdog generates a POR reset to the device.

Key features of the IWDT include:

- A 25-bit counter with closed and open window
- Counter driven from LFOSC (fixed 32kHz clock path) with a programmable clock divider
- Eight selectable watchdog timer periods

For more details, see the IWDT chapter of the [MSPM0 L-Series 32MHz Microcontrollers Technical Reference Manual](#).

### 8.16 RTC\_B

The RTC\_B instance of the real-time clock operates off of a 32kHz input clock source (typically a low frequency crystal) and provides a time base to the application with multiple options for interrupts to the CPU. The RTC\_B provides common key features in relation to the Low-Frequency Sub System (LFSS).

Common key features of the RTC\_B include:

- Counters for seconds, minutes, hours, day of the week, day of the month, month, and year
- Binary or BCD format
- Leap-year handling
- One customizable alarm interrupt based on minute, hour, day of the week, and day of the month
- Interval alarm interrupt to wake every minute, every hour, at midnight, or at noon
- Interval alarm interrupt providing periodic wake-up at 4096, 2048, 1024, 512, 256, or 128 Hz
- Interval alarm interrupt providing periodic wake-up at 64, 32, 16, 8, 4, 2, 1, and 0.5 Hz
- Calibration for crystal offset error (up to +/- 240ppm)
- Compensation for temperature drift (up to +/- 240ppm)
- RTC clock output to pin for calibration

Table 8-9 shows the RTC features supported in this device.

**Table 8-9. RTC\_B Key Features**

RTC Features	RTC_B
Power enable register	-
Real-time clock and calendar mode providing seconds, minutes, hours, day of week, day of month, and year	Yes
Selectable binary or binary-coded decimal (BCD) format	Yes
Leap-year correction (valid for year 1901 through 2099)	Yes
Two customizable calendar alarm interrupts based on minute, hour, day of the week, and day of the month	Yes
Interval alarm interrupt to wake every minute, every hour, at midnight, or at noon	Yes
Periodic interrupt to wake at 4096, 2048, 1024, 512, 256, or 128Hz	Yes
Periodic interrupt to wake at 64, 32, 16, 8, 4, 2, 1, and 0.5Hz	Yes
Interrupt capability down to STANDBY mode with STOPCLKSTBY	Yes
Calibration for crystal offset error and crystal temperature drift (up to ±240 ppm total)	Yes
RTC clock output to pin for calibration (GPIO)	Yes
RTC clock output to pin for calibration (TIO)	-
Three -bit prescaler for heartbeat function with interrupt generation	-
RTC external clock selection of untrimmed 32kHz, trimmed 512Hz, 256Hz or 1Hz	-
RTC time stamp capture upon detection of a timer stamp event, including: <ul style="list-style-type: none"> <li>• TIO event</li> <li>• VDD fail event</li> </ul>	-
RTC counter lock function	-

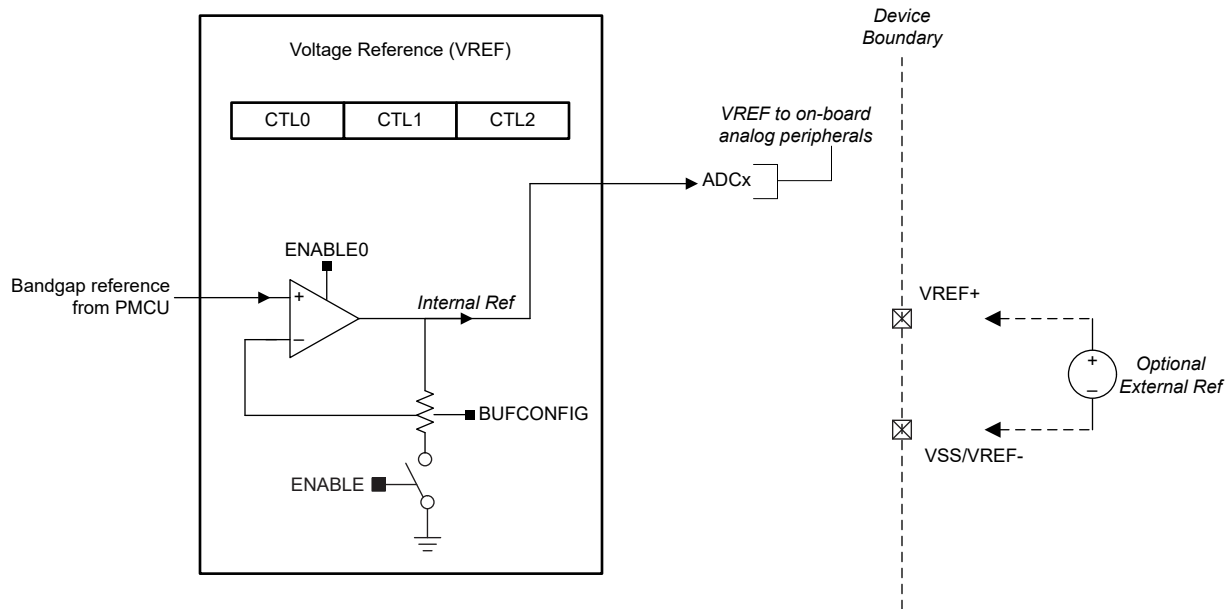
For more details, see the RTC chapter of the [MSPM0 L-Series 32MHz Microcontrollers Technical Reference Manual](#).

### 8.17 VREF

The voltage reference module (VREF) contains a configurable voltage reference buffer dedicated for the on-board ADC. The devices also support connection of an external reference for applications in which higher accuracy is required.

VREF features include:

- 1.4V and 2.5V user-selectable internal references.
- Internal reference supports ADC operation up to 515ksps
- Support for bringing in an external reference on VREF+ and VREF- device pins
- No decoupling capacitor is required for proper operation. See [Figure 8-1](#) for more details



**Figure 8-1. VREF module**

For more details, see the VREF chapter of the [MSPM0 L-Series 32MHz Microcontrollers Technical Reference Manual](#).

## 8.18 COMP

The comparator peripheral in the device compares the voltage levels on two inputs terminals and provides a digital output based on this comparison. It supports the following key features:

- Programmable hysteresis
- Programmable reference voltage:
  - External reference voltage (VREF IO)
  - Integrated 8-bit reference DAC
- Configurable operation modes:
  - High speed mode
  - Lower power mode
- Programmable output glitch filter delay
- Supports 6 blanking sources from TIMx instances (see [Table 8-10](#))
- Support output wake up device from all low power modes
- Output connected to advanced timer fault handling mechanism
- The IPSEL and IMSEL bits in comparator registers can be used to select the comparator channel inputs from device pins
- 8-bit reference DAC can be used to output to device pins

**Table 8-10. COMP0 Input Channel Selection**

IPSEL / IMSEL BITS	POSITIVE TERMINAL INPUT	NEGATIVE TERMINAL INPUT
0x0	COMP0_IN0+	COMP0_IN0-
0x1	COMP0_IN1+	COMP0_IN1-
0x2	COMP0_IN2+	COMP0_IN2-

**Table 8-10. COMP0 Input Channel Selection (continued)**

IPSEL / IMSEL BITS	POSITIVE TERMINAL INPUT	NEGATIVE TERMINAL INPUT
0x3	COMP0_IN3+	-
0x5	-	Temperature Sensor

**Table 8-11. COMP0 Blanking Source Table**

CTL2.BLANKSRC	Blanking Source Selected
1	TIMA0.CC2
2	TIMA0.CC3
3	TIMA0.CC1
4	TIMG14.CC1
5	TIMG1.CC1
6	TIMG2.CC1

For more information about device analog connections, refer to [Analog Connections](#).

For more details, see the COMP chapter of the [MSPM0 L-Series 32MHz Microcontrollers Technical Reference Manual](#).

## 8.19 Security

This device offers several security features, including:

- Debug security
- Device identify
- AES-128/256 accelerator with support for GCM/GMAC, CCM/CBC-MAC, CBC, CTR
- Flexible firewalls for protecting code and data
  - Flash write-erase protection
  - Flash read-execute protection
  - Flash IP protection
  - SRAM write-execute mutual exclusion
- Secure boot
- Secure firmware update
- Secure key storage for up to two 128-bit AES keys
- Customer secure code
- Cyclic Redundancy Checker (CRC-16) with support for custom polynomial

For more details, see the Security chapter of the [MSPM0 L-Series 32MHz Microcontrollers Technical Reference Manual](#).

## 8.20 AESADV

The AES advanced (AESADV) accelerator module performs encryption and decryption of 128-bit data blocks with a 128-bit or 256-bit key in hardware according to the advanced encryption standard (AES). AES is a symmetric-key block cipher algorithm specified in FIPS PUB 197.

The AESADV accelerator features include:

- AES operation with 128-bit and 256-bit keys
- Key scheduling in hardware
- Enc/decrypt only modes: CBC, CFB-1, CFB-8, CFB-128, OFB-128, CTR/ICM
- Authentication only modes: CBC-MAC, CMAC
- AES-CCM (using AES-CTR mode and AES-CBC-MAC)
- AES-GCM (using AES-CTR mode and GHASH, supports basic GHASH operation when selecting no encryption)
- AES-CCM and AES-GCM modes support continuation with hold/resume of payload data
- 32-bit word access to provide key data, input data, and output data
- AESADV ready interrupt

- DMA triggers for input/output data
- Supported in RUN and SLEEP (see the [Section 8.2](#))

For more details, see the AESADV chapter of the [MSPM0 L-Series 32MHz Microcontrollers Technical Reference Manual](#).

### 8.21 CRC

The cyclical redundancy check (CRC) module provides a signature for an input data sequence. Key features of the CRC module include:

- Support for 16-bit CRC based on CRC16-CCITT
- Support for bit reversal

For more details, see the CRC chapter of the [MSPM0 L-Series 32MHz Microcontrollers Technical Reference Manual](#).

### 8.22 Keystore

The Keystore controller provides secure management of the Advanced Encryption Engine (AES) keys. The use-model of the keystore controller is to securely deposit keys into it during the execution of customer secure code, and have the AES engine access them subsequently in a secure manner without leaking any key data to observers. Two 128-bit or one 256-bit keys can be stored in the keystore's key slots. The keystore and its interaction with the AES engine are designed for secure operation including thwarting partial key modification attacks.

For more details, see the KEYSTORE chapter of the [MSPM0 L-Series 32MHz Microcontrollers Technical Reference Manual](#).

### 8.23 UNICOMM (UART/I<sup>2</sup>C/SPI)

UNICOMM is a highly flexible peripheral which can be configured as a UART, SPI, I<sup>2</sup>C-Controller or I<sup>2</sup>C-Target function. The user can select one of the serial interfaces before configuration and data transfer. The peripheral uses a common FIFO per instance to maximize the device capability based on the operating state. A serial peripheral group combines one or more UNICOMM for special functions like I<sup>2</sup>C loopback and is an optional configuration. [Table 8-12](#) describes the grouping of UNICOMM, peripheral serial interfaces available and FIFO depth.

**Table 8-12. UNICOMM (UCx) Serial Peripheral**

SERIAL PERIPHERAL GROUP	UNICOMM INSTANCE	Local UCx Index	Global UCx Index	UART	I <sup>2</sup> C Controller	I <sup>2</sup> C Target	SPI	FIFO depth
SPG0 (PD0)	UC4	0	4	Yes	-	-	Yes	4
	UC6	1	6	-	Yes	-	-	4
	UC7	2	7	-	-	Yes	-	4
SPG1 (PD1)	UC8	0	8	Yes	-	-	Yes	4
	UC11	1	11	Yes	-	-	-	1

#### 8.23.1 UART (UNICOMM)

The UART peripheral function provide the following key features:

- Standard asynchronous communication bits for start, stop, and parity
- Fully programmable serial interface
  - 5, 6, 7 or 8 data bits
  - Even, odd, stick, or no-parity bit generation and detection
  - 1 or 2 stop bit generation

- Line-break detection
- Glitch filter on the input signals
- Programmable baud rate generation with oversampling by 16, 8 or 3
- Local Interconnect Network (LIN) mode support
- Support transmit and receive loopback mode operation
- See [Table 8-13](#) for detail information on supported protocols

**Table 8-13. UART (UNICOMM) Features**

Supported Features	UC4.UART	UC8.UART, UC11.UART
Active in Stop and Standby Mode	Yes	-
Support hardware flow control	Yes	Yes
Support 9-bit configuration	Yes	Yes
Support LIN mode	Yes	-
Support DALI	Yes	-
Support IrDA	Yes	-
Support ISO7816 Smart Card	Yes	-
Support Manchester coding	Yes	-

For more details, see the UART (UNICOMM) chapter of the [MSPM0 L-Series 32MHz Microcontrollers Technical Reference Manual](#)

### 8.23.2 I2C (UNICOMM)

The inter-integrated circuit interface (I<sup>2</sup>C) peripherals in these devices provide bidirectional data transfer with other I2C devices on the bus and support the following key features:

- 7-bit and 10-bit addressing mode with multiple 7-bit target addresses
- Multiple-controller transmitter or receiver mode
- Target receiver or transmitter mode with configurable clock stretching
- Support Standard-mode (Sm), with a bit rate up to 100 kbit/s
- Support Fast-mode (Fm), with a bit rate up to 400 kbit/s
- Support Fast-mode Plus (Fm+), with a bit rate up to 1 Mbit/s
  - Supported on open drain IOs (ODIO) and high-drive (HDIO) IOs only
- Separated transmit and receive FIFOs support DMA data transfer
- Wakeup from low power mode on address match
- Support digital glitch filter for input signal glitch suppression
- See [Table 8-14](#) and [Table 8-15](#) for detailed information on supported features for controller and target functions

**Table 8-14. I2C Controller (UNICOMM) Features**

Supported Features	UC6.I2C,
Supports standard-mode (Sm)	Yes
Supports Fast-mode (Fm)	Yes
Supports Fast-mode Plus (Fm+)	Yes
Supports analog glitch filter	Yes
Supports digital glitch filter	-
Supports burst mode	Yes
Supports SMBus mode	Yes

**Table 8-15. I2C Target (UNICOMM) Features**

Supported Features	UC7.I2C
Supports standard-mode (Sm)	Yes
Supports Fast-mode (Fm)	Yes
Supports Fast-mode Plus (Fm+)	Yes
Supports analog glitch filter	Yes
Supports digital glitch filter	-
Supports second target address & mask	Yes
Supports SMBus mode	Yes
Supports low power wakeup	Yes

For more details, see the I2C (UNICOMM) chapter of the [MSPM0 L-Series Technical Reference Manual](#).

### 8.23.3 SPI (UNICOMM)

The serial peripheral interface (SPI) peripherals function support the following key features:

- Support ULPCLK/2 bit rate and up to 16Mbits/s in both controller and peripheral mode
- Configurable as a controller or a peripheral
- Supports single parity for transmit and receive
- Programmable clock prescaler and bit rate
- Programmable data frame size from 4 bits to 16 bits (controller mode) and 7 bits to 16 bit (peripheral mode)
- Transmit and receive FIFOs (4 entries each with 16 bits per entry) supporting DMA data transfer
- Supports TI mode and Motorola mode
- Support single bit parity in both transmit and receive paths
- See [Table 8-16](#) for detailed information on supported features

**Table 8-16. SPI (UNICOMM) Features**

Supported Features	UC4.SPI, UC8.SPI
Controller and Peripheral mode	Yes
Supports Parity function	Yes
Supports Repeat mode transfer	-
Supports Receive timeout	-
Supports Command/Data control	-
Supports 4 chip selects	-

For more details, see the SPI (UNICOMM) chapter of the [MSPM0 L-Series Technical Reference Manual](#).

### 8.24 WWDT

The windowed watchdog timer (WWDT) can be used to supervise the operation of the device, specifically code execution. The WWDT can be used to generate a reset or an interrupt if the application software does not successfully reset the watchdog within a specified window of time. Key features of the WWDT include:

- 25-bit counter
- Programmable clock divider
- Eight software selectable watchdog timer periods
- Eight software selectable window sizes
- Support for stopping the WWDT automatically when entering a sleep mode
- Interval timer mode for applications which do not require watchdog functionality

For more details, see the WWDT chapter of the [MSPM0 L-Series 32MHz Microcontrollers Technical Reference Manual](#).

## 8.25 Timers (TIMx)

There are two timer peripherals in these devices support that following key features: TIMBx (basic timer), TIMGx (general-purpose timer) and TIMAx (advanced timer). TIMGx is a subset of TIMAx, which means these timers share many common features that are compatible in software. For specific configuration, see [Table 8-17](#):

Specific features for the general-purpose timer (**TIMGx**) include:

- 16-bit and 32-bit timers with up, down or up-down counting modes, with repeat-reload mode
- Selectable and configurable clock source
- 8-bit programmable prescaler to divide the counter clock frequency
- Two independent CC channels for
  - Output compare
  - Input capture
  - PWM output
  - One-shot mode
- Support synchronization and cross trigger among different TIMx instances in the same power domain
- Support interrupt/DMA trigger generation and cross peripherals (such as ADC) trigger capability

Specific features for the advanced timer (**TIMAx**) include:

- 16-bit timer with up, down or up-down counting modes, with repeat-reload mode
- Selectable and configurable clock source
- 8-bit programmable prescaler to divide the counter clock frequency
- Repeat counter to generate an interrupt or event only after a given number of cycles of the counter
- Up to four independent CC channels for
  - Output compare
  - Input capture
  - PWM output
  - One-shot mode
- Two additional capture/compare channels for internal events (CC4/CC5)
- Shadow register for load and CC register available in TIMA0
- Complementary output PWM
- Asymmetric PWM with programmable dead band insertion
- Fault handling mechanism to make sure the output signals in a safe user-defined state when a fault condition is encountered
- Support synchronization and cross trigger among different TIMx instances in the same power domain
- Support interrupt and DMA trigger generation and cross peripherals (such as ADC) trigger capability
- Two additional capture/compare channels for internal events

Specific features for the basic software timer (**TIMBx**) include:

- Support for a counter array containing 4 counters
- Each counter is a 16 bit counter
- Clocked by the bus clock
- Ability to concatenate 2 or more counters to create longer time durations
- Ability to measure timing properties of external events
  - Duration between 2 pulses on an event
  - Counting the number of events
  - Ability to start/stop the counter based on external events or internal events

**Table 8-17. TIMx Instance Configuration**

Instance	Power Domain	Counter Resolution	Prescaler	Repeat Counter	CCP Channels (External/Internal)	External PWM Channels	Phase Load	Shadow Load	Shadow CCs	Deadband	Fault Handler	QEI / Hall Input Mode
TIMB3	PD0	16 bit	–	–	–	–	–	–	–	–	–	–
TIMB2	PD0	16 bit	–	–	–	–	–	–	–	–	–	–
TIMB1	PD0	16 bit	–	–	–	–	–	–	–	–	–	–

**Table 8-17. TIMx Instance Configuration (continued)**

Instance	Power Domain	Counter Resolution	Prescaler	Repeat Counter	CCP Channels (External/Internal)	External PWM Channels	Phase Load	Shadow Load	Shadow CCs	Deadband	Fault Handler	QEI / Hall Input Mode
TIMB0	PD0	16 bit	–	–	–	–	–	–	–	–	–	–
TIMG2	PD0	16 bit	8 bit	–	2	–	–	–	–	–	–	–
TIMG1	PD0	16 bit	8 bit	–	2	–	–	–	–	–	–	–
TIMG14	PD0	16 bit	8bit	–	4	–	–	–	–	–	–	–
TIMA0	PD1	16 bit	8 bit	8-bit	4	Yes	Yes	Yes	Yes	Yes	–	–

For more details, see the TIMx chapter of the [MSPM0 L-Series 32MHz Microcontrollers Technical Reference Manual](#).

## 8.26 LCD

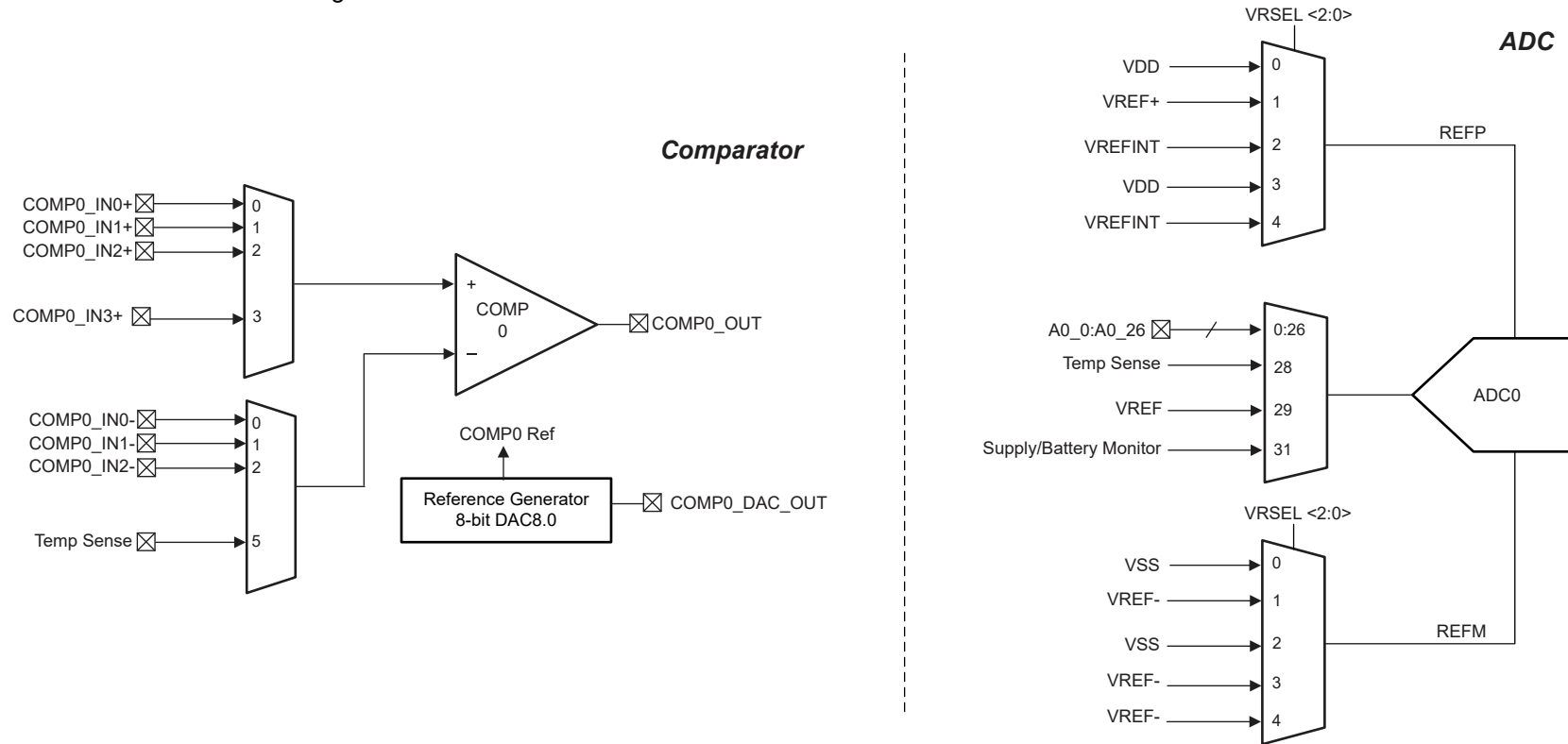
The Liquid Crystal Display (LCD) controller directly drives LCD displays through the segment (SEG) and COM voltage signals. The controller can support 2-mux to 8-mux LCD glasses. The main features of the LCD controller are:

- Display memory
- Standby mode support
- Configurable SEG and COM pins
- Automatic signal generation
- Configurable frame frequency
- Blinking of individual segments with separate blinking memory for static and 2-4 mux LCD
- Blinking of complete display for 5-8 mux LCDs
- Regulated charge pump up to 3.6V (typical)
- Internal resistor divider for generating bias voltages
- Contrast control by software
- Internal resistor divider for generating bias voltages
- Ability to use LCD IOs as GPIOs or analog signals when pins are not used for LCD operation
- Supports static, 1/3 and 1/4 bias modes. 1/2 bias mode is not supported.

For more details, see the LCD chapter of the [MSPM0 L-Series 32MHz Microcontrollers Technical Reference Manual](#).

## 8.27 Device Analog Connections

Figure 8-2 shows the internal analog connection of the device.



**Figure 8-2. Device Analog Connection**

## 8.28 Input/Output Diagrams

The IOMUX manages the selection of which peripheral function is to be used on a digital IO. It also provides the controls for the output driver, input path, and the wake-up logic for wakeup from SHUTDOWN mode. For more information, refer to the IOMUX section of the [MSPM0 L-Series 32MHz Microcontrollers Technical Reference Manual](#).

The mixed-signal IO pin slice diagram for a full featured IO pin is shown in [Figure 8-3](#). Not all pins will have analog functions, wake-up logic, drive strength control, and pullup or pulldown resistors available. See the device-specific data sheet for detailed information on what features are supported for a specific pin.

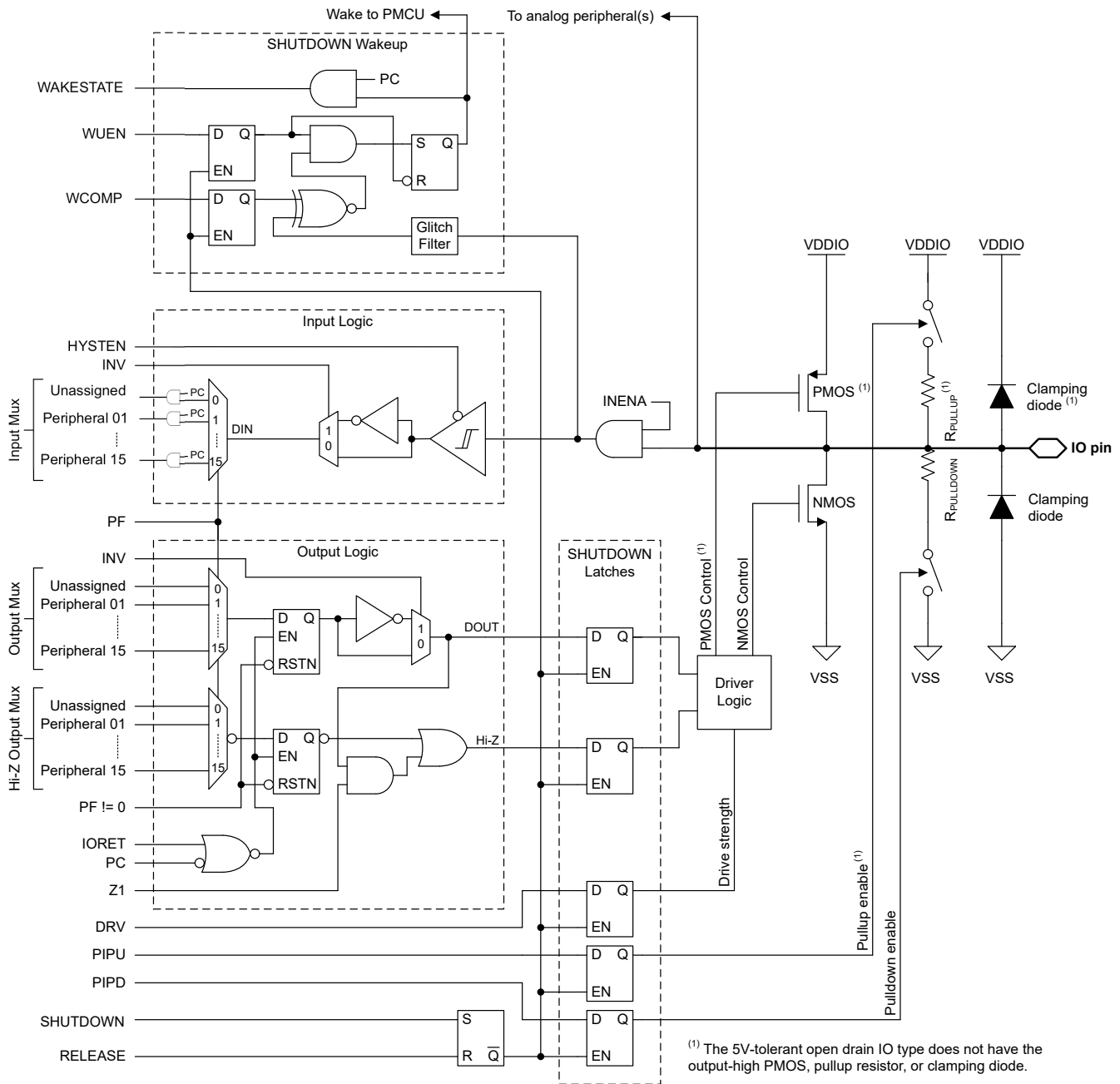


Figure 8-3. Superset Input/Output Diagram

## 8.29 DEBUGSS

The debug subsystem (DEBUGSS) interfaces the ARM Serial Wire Debug (SWD) two-wire physical interface to multiple debug functions within the device. MSPM0 devices support debugging of processor execution and the device state. The DEBUGSS also provides a mailbox system for communicating with software through SWD.

Key features provided by the debug subsystem include:

- The ARM Serial Wire Debug (SWD) two-wire (SWDIO, SWCLK) debug interface, compatible with both TI and 3<sup>rd</sup> party debug probes
  - On-chip pullup and pulldown resistors for SWDIO and SWCLK, respectively, enabled by default
  - Support for disabling SWD functions to use SWD pins as general-purpose input/output pins
  - Support for debug on all low power modes
- Debug of the processor
  - Run, halt, and step debug support
  - 2 hardware breakpoints (BPU)
  - 1 hardware watchpoints (DWT)
  - Supporting software breakpoints
- Software-configurable peripheral behavior during processor debug
  - Ability to free run select peripherals through debug halt
  - Ability to halt select peripherals on a debug halt
  - Ability to request reset and mode changes to the PMCU
- Mailbox (DSSM) for passing data and control signals between the SWD interface and boot ROM (as well as application software)
- Support for various security features, including SWD lockout and password authenticated debugging

For more details, see the DEBUGSS chapter of the [MSPM0 L-Series 32MHz Microcontrollers Technical Reference Manual](#).

## 8.30 Serial Wire Debug Interface

A serial wire debug (SWD) two-wire interface is provided via an Arm compatible serial wire debug port (SW-DP) to enable access to multiple debug functions within the device.

**Table 8-18. Serial Wire Debug Pin Requirements and Functions**

DEVICE SIGNAL	DIRECTION	SWD FUNCTION
SWCLK	Input	Serial wire clock from debug probe
SWDIO	Input/Output	Bi-directional (shared) serial wire data

For a complete description of the debug functionality offered on MSPM0 devices, see the Debug chapter of the [MSPM0 L-Series 32MHz Microcontrollers Technical Reference Manual](#).

## 8.31 Bootstrap Loader (BSL)

The bootstrap loader (BSL) enables configuration of the device as well as programming of the device memory through a UART or I2C serial interface. Access to the device memory and configuration through the BSL is protected by a 256-bit user-defined password, and it is possible to completely disable the BSL in the device configuration, if desired. The BSL is enabled by default from TI to support use of the BSL for production programming.

A minimum of two pins are required to use the BSL: the BSLRX and BSLTX signals (for UART), or the BSLSCL and BLSLSDA signals (for I<sup>2</sup>C). Additionally, one or two additional pins (BSL\_invoke and NRST) may be used for controlled invocation of the bootloader by an external host.

If enabled, the BSL may be invoked (started) in the following ways:

- The BSL is invoked during the boot process if the BSL\_invoke pin state matches the defined BSL\_invoke logic level. If the device fast boot mode is enabled, this invocation check is skipped. An external host can force the device into the BSL by asserting the invoke condition and applying a reset pulse to the NRST pin to

- trigger a BOOTRST, after which the device will verify the invoke condition during the reboot process and start the BSL if the invoke condition matches the expected logic level.
- The BSL is automatically invoked during the boot process if the reset vector and stack pointer are left unprogrammed. As a result, a blank device from TI will invoke the BSL during the boot process without any need to provide a hardware invoke condition on the BSL\_invoke pin. This enables production programming using just the serial interface signals.
  - The BSL may be invoked at runtime from application software by issuing a SYSRST with BSL entry command.

**Table 8-19. BSL Pin Requirements and Functions**

DEVICE SIGNAL	CONNECTION	BSL FUNCTION
BSLRX	Required for UART	UART receive signal (RXD), an input
BSLTX	Required for UART	UART transmit signal (TXD) an output
BSLSCL	Required for I2C	I <sup>2</sup> C BSL clock signal (SCL)
BSLSDA	Required for I2C	I <sup>2</sup> C BSL data signal (SDA)
BSL_invoke	Optional	Active-high digital input used to start the BSL during boot
NRST	Optional	Active-low reset pin used to trigger a reset and subsequent check of the invoke signal (BSL_invoke)

For a complete description of the BSL functionality and command set, see the MSPM0 boot strap loader user's guide.

### 8.32 Device Factory Constants

All devices include a memory-mapped FACTORY region which provides read-only data describing the capabilities of a device as well as any factory-provided trim information for use by application software. Please refer to Factory Constants chapter of the *MSPM0 L-Series 32MHz Microcontrollers Technical Reference Manual* for more information.

**Table 8-20. DEVICEID**

DEVICEID address is 0x41C4.0004, PARTNUM is bit 12 to 27, MANUFACTURER is bit 1 to 11.

Device	PARTNUM	MANUFACTURER
MSPM0L2116	0xBBC7	0x17
MSPM0L2117	0xBBC7	0x17
MSPM0L1126	0xBBC7	0x17
MSPM0L1127	0xBBC7	0x17

**Table 8-21. USERID**

USERID address is 0x41C4.0008, PART is bit 0 to 15, VARIANT is bit 16 to 23

Device	Part	Variant
MSPM0L2116SPMR	33DD	B0
MSPM0L2116SRSKR	33DD	B1
MSPM0L2116SPTR	33DD	B2
MSPM0L2116SRGZR	33DD	B3
MSPM0L2116SVFCR	33DD	B4
MSPM0L2116SRHBR	33DD	B5
MSPM0L2116S32DGSR	33DD	B6
MSPM0L2116S28DGSR	33DD	B7
MSPM0L2116SRUYR	33DD	B8
MSPM0L2116SRGER	33DD	B9
MSPM0L2117SPMR	E19C	11

**Table 8-21. USERID (continued)**

USERID address is 0x41C4.0008, PART is bit 0 to 15, VARIANT is bit 16 to 23

Device	Part	Variant
MSPM0L2117SRSKR	E19C	12
MSPM0L2117SPTR	E19C	13
MSPM0L2117SRGZR	E19C	14
MSPM0L2117SVFCR	E19C	15
MSPM0L2117SRHBR	E19C	16
MSPM0L2117S32DGSR	E19C	17
MSPM0L2117S28DGSR	E19C	18
MSPM0L2117SRUYR	E19C	19
MSPM0L2117SRGER	E19C	20
MSPM0L1127SPMR	DD91	21
MSPM0L1127SRSKR	DD91	22
MSPM0L1127SPTR	DD91	23
MSPM0L1127SRGZR	DD91	24
MSPM0L1127SVFCR	DD91	25
MSPM0L1127SRHBR	DD91	26
MSPM0L1127S32DGSR	DD91	27
MSPM0L1127S28DGSR	DD91	28
MSPM0L1127SRUYR	DD91	29
MSPM0L1127SRGER	DD91	30
MSPM0L1126SPMR	8464	A0
MSPM0L1126SRSKR	8464	A1
MSPM0L1126SPTR	8464	A2
MSPM0L1126SRGZR	8464	A3
MSPM0L1126SVFCR	8464	A4
MSPM0L1126SRHBR	8464	A5
MSPM0L1126S32DGSR	8464	A6
MSPM0L1126S28DGSR	8464	A7
MSPM0L1126SRUYR	8464	A8
MSPM0L1126SRGER	8464	A9

### 8.33 Identification

#### Revision and Device Identification

The hardware revision and device identification values are stored in the memory-mapped FACTORY region, refer to Device Factory Constants section, which provides read-only data describing the capabilities of a device as well as any factory-provided trim information for use by application software. Refer to the Factory Constants chapter of the [MSPM0 L-Series 32MHz Microcontrollers Technical Reference Manual](#) for more information.

The device revision and identification information are also included as part of the top-side marking on the device package. The device-specific errata sheet describes these markings (see [Section 10.4](#)).

## 9 Applications, Implementation, and Layout

### 9.1 Typical Application

#### Note

Information in the following applications sections is not part of the TI component specification, and TI does not warrant its accuracy or completeness. TI's customers are responsible for determining suitability of components for their purposes, as well as validating and testing their design implementation to confirm system functionality.

#### 9.1.1 Schematic

TI recommends connecting a combination of a 10 $\mu$ F and a 0.1 $\mu$ F low-ESR ceramic decoupling capacitor to the VDD and VSS pins. Higher-value capacitors may be used but can impact supply rail ramp-up time. Decoupling capacitors must be placed as close as possible to the pins that they decouple (within a few millimeters).

The NRST reset pin is required to connect an external 47k $\Omega$  pullup resistor with a 1000pF pulldown capacitor.

A 0.47- $\mu$ F tank capacitor is required for the VCORE pin and must be placed close to the device with minimum distance to the device ground. Do not connect other circuits to the VCORE pin.

For devices supporting external crystals, external bypass capacitors for the crystal oscillator pins are required. Refer to *MSPM0 L-Series 32MHz Microcontrollers Technical Reference Manual* which explains how to calculate the capacitor value.

For 5V-tolerant open drain IOs (ODIO), a pullup resistor is required to output a logic high signal. This is required for I<sup>2</sup>C and UART functions if the ODIO are used.

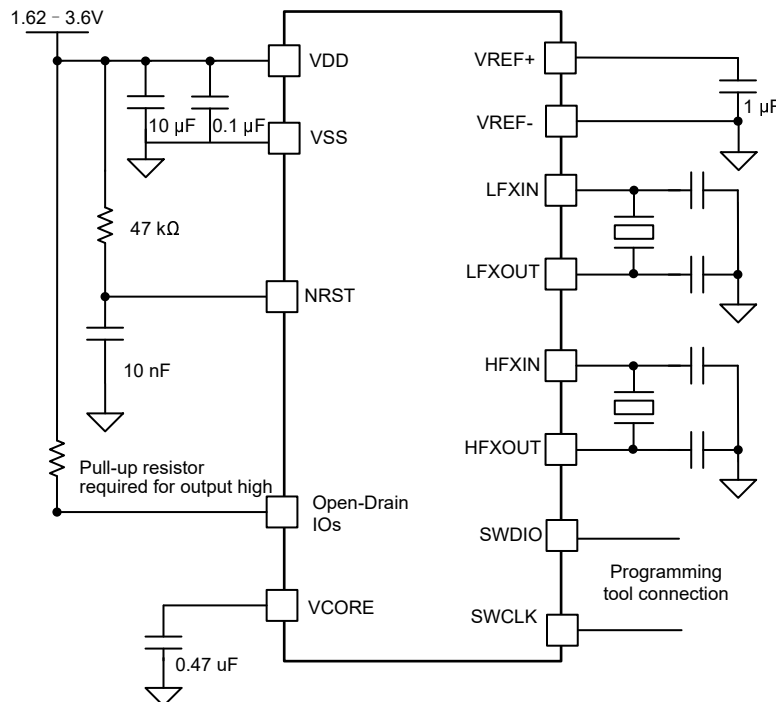


Figure 9-1. Typical Application Schematic

## 10 Device and Documentation Support

TI offers an extensive line of development tools. Tools and software to evaluate the performance of the device, generate code, and develop solutions are listed below.

### 10.1 Getting Started and Next Steps

For more information on the MSP low-power microcontrollers and the tools and libraries that are available to help with development, visit the Texas Instruments [Arm Cortex-M0+ MCUs](#) page.

### 10.2 Device Nomenclature

To designate the stages in the product development cycle, TI assigns prefixes to the part numbers of all MSP MCU devices and support tools. Each MSP MCU commercial family member has one of two prefixes: MSP or X. These prefixes represent evolutionary stages of product development from engineering prototypes (X) through fully qualified production devices (MSP).

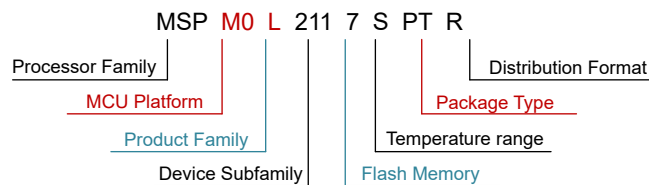
**X** – Experimental device that is not necessarily representative of the final device's electrical specifications

**MSP** – Fully qualified production device

**X** devices are shipped against the following disclaimer:

"Developmental product is intended for internal evaluation purposes." MSP devices have been characterized fully, and the quality and reliability of the device have been demonstrated fully. TI's standard warranty applies. Predictions show that prototype devices (X) have a greater failure rate than the standard production devices. TI recommends that these devices not be used in any production system because their expected end-use failure rate still is undefined. Only qualified production devices are to be used.

TI device nomenclature also includes a suffix with the device family name. This suffix indicates the temperature range, package type, and distribution format. [Figure 10-1](#) provides a legend for reading the complete device name.



**Figure 10-1. Device Nomenclature**

**Table 10-1. Device Nomenclature**

<b>Processor Family</b>	MSP = Mixed-signal processor X= Experimental silicon
<b>MCU Platform</b>	M0 = Arm based 32-bit M0+
<b>Product Family</b>	L = 32MHz frequency
<b>Device Subfamily</b>	1126/7 = 32MHz frequency, ADC, CMP 2116/7 = 32MHz frequency, ADC, CMP, LCD
<b>Flash Memory</b>	6 = 64KB 7= 128KB
<b>Temperature Range</b>	S = –40°C to 125°C
<b>Package Type</b>	See the <i>Device Comparison</i> section and <a href="https://www.ti.com/packaging">https://www.ti.com/packaging</a>
<b>Distribution Format</b>	R = Large reel No marking = Tube or tray

For orderable part numbers of MSP devices in different package types, see the Package Option Addendum of this document, [ti.com](http://ti.com), or contact your TI sales representative.

## 10.3 Tools and Software

### Design Kits and Evaluation Modules

#### [MSPM0 LaunchPad \(LP\) Boards: LP-MSPM0L2117](#)

Empowers you to immediately start developing on the industry's best integrated analog and most cost-optimized general purpose MSPM0 MCU family. Exposes all device pins and functionality; includes some built-in circuitry, out-of-box software demos, and on-board XDS110 debug probe for programming/debugging/EnergyTrace. The LP ecosystem includes dozens of [BoosterPack](#) stackable plug-in modules to extend functionality.

### Embedded Software

#### [MSPM0 Software Development Kit \(SDK\)](#)

Contains software drivers, middleware libraries, documentation, tools, and code examples that create a familiar and easy user experience for all MSPM0 devices.

### Software Development Tools

#### [TI Cloud Tools](#)

Start your evaluation and development on a web browser without any installation. Cloud tools also have a downloadable, offline version.

#### [TI Resource Explorer SysConfig](#)

Online portal to TI SDKs. Accessible in CCS IDE or in TI Cloud Tools.

Intuitive GUI to configure device and peripherals, resolve system conflicts, generate configuration code, and automate pin mux settings. Accessible in CCS IDE or in TI Cloud Tools. ([offline version](#))

#### [MSP Academy](#)

Great starting point for all developers to learn about the MSPM0 MCU Platform with training modules that span a wide range of topics. Part of TIRex.

#### [GUI Composer](#)

GUIs that simplify evaluation of certain MSPM0 features, such as configuring and monitoring a fully integrated analog signal chain without any code needed.

### IDE & compiler toolchains

#### [Code Composer Studio™ \(CCS\)](#)

Includes [TI Arm-Clang](#) compiler. Supports all TI Arm Cortex MCUs and boasts competitive code size performance advantages, fast compile time, code coverage support, safety certification support, and completely free to use.

#### [IAR Embedded Workbench® IDE](#)

#### [Keil® MDK IDE](#)

#### [GNU Arm Embedded Toolchain](#)

## 10.4 Documentation Support

To receive notification of documentation updates, navigate to the device product folder on [ti.com](http://ti.com). Click on *Subscribe to updates* to register and receive a weekly digest of any product information that has changed. For change details, review the revision history included in any revised document.

The following documents describe the MSPM0 MCUs. Copies of these documents are available on the Internet at [www.ti.com](http://www.ti.com).

### Technical Reference Manual

#### [MSPM0 L-Series 32MHz Microcontrollers](#)

This manual describes the modules and peripherals of the family of devices. Each description presents the module or peripheral in a general sense. Not all features

[Technical Reference Manual](#)

and functions of all modules or peripherals are present on all devices. In addition, modules or peripherals can differ in their exact implementation on different devices. Pin functions, internal signal connections, and operational parameters differ from device to device. See the device-specific data sheet for these details.

**Errata**

[MSPM0L112 and MSPM0L211x Microcontroller Errata](#)

This document describes the known exceptions to the functional specifications (advisories).

**10.5 Support Resources**

[TI E2E™ support forums](#) are an engineer's go-to source for fast, verified answers and design help — straight from the experts. Search existing answers or ask your own question to get the quick design help you need.

Linked content is provided "AS IS" by the respective contributors. They do not constitute TI specifications and do not necessarily reflect TI's views; see TI's [Terms of Use](#).

**10.6 Trademarks**

LaunchPad™, Code Composer Studio™, and TI E2E™ are trademarks of Texas Instruments.

Arm® and Cortex® are registered trademarks of Arm Limited.

All trademarks are the property of their respective owners.

**10.7 Electrostatic Discharge Caution**



This integrated circuit can be damaged by ESD. Texas Instruments recommends that all integrated circuits be handled with appropriate precautions. Failure to observe proper handling and installation procedures can cause damage.

ESD damage can range from subtle performance degradation to complete device failure. Precision integrated circuits may be more susceptible to damage because very small parametric changes could cause the device not to meet its published specifications.

**10.8 Glossary**

[TI Glossary](#) This glossary lists and explains terms, acronyms, and definitions.

**11 Revision History**

NOTE: Page numbers for previous revisions may differ from page numbers in the current version.

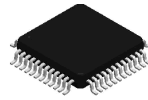
DATE	REVISION	NOTES
December 2025	1.0	Initial Release

## 12 Mechanical, Packaging, and Orderable Information

The following pages include mechanical, packaging, and orderable information. This information is the most current data available for the designated devices. This data is subject to change without notice and revision of this document. For browser-based versions of this data sheet, refer to the left-hand navigation.

### 12.1 Mechanical Data

The following pages include mechanical, packaging, and orderable information. This information is the most current data available for the designated devices. This data is subject to change without notice and revision of this document. For browser-based versions of this data sheet, refer to the left-hand navigation.

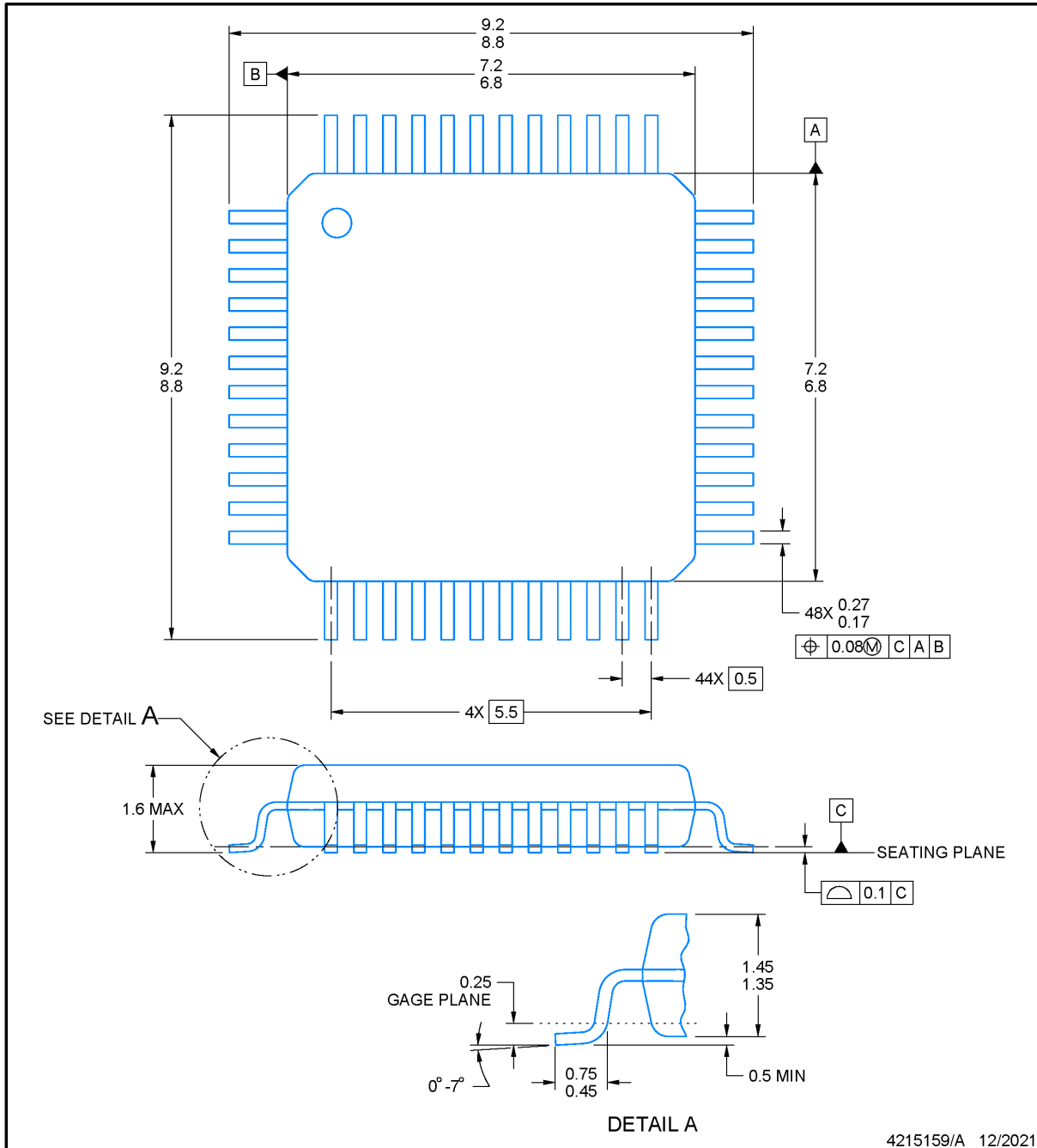


**PT0048A**

**PACKAGE OUTLINE**

**LQFP - 1.6 mm max height**

LOW PROFILE QUAD FLATPACK



NOTES:

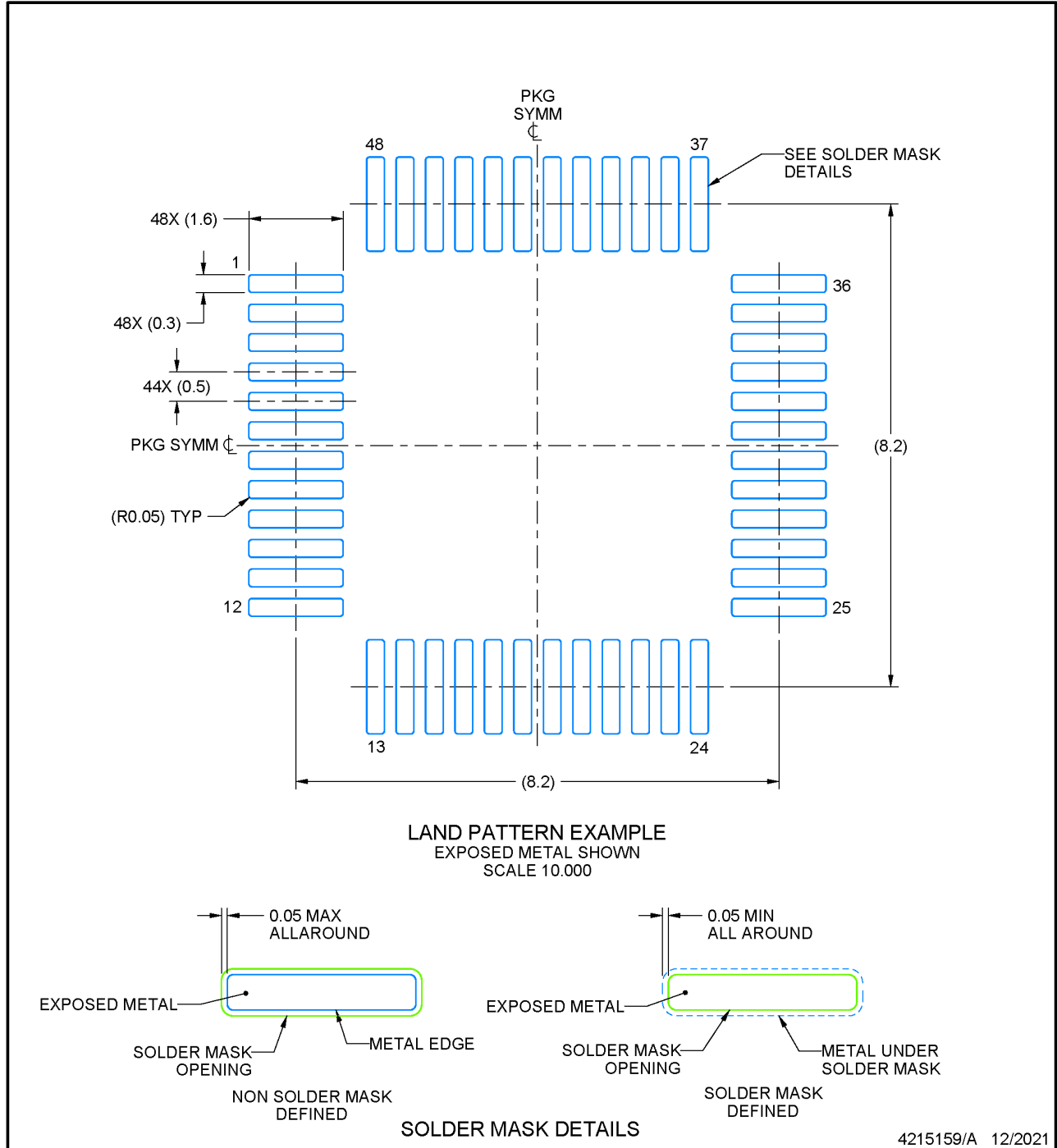
1. All linear dimensions are in millimeters. Any dimensions in parenthesis are for reference only. Dimensioning and tolerancing per ASME Y14.5M.
2. This drawing is subject to change without notice.
3. Reference JEDEC registration MS-026.
4. This may also be a thermally enhanced plastic package with leads connected to the die pads.

# EXAMPLE BOARD LAYOUT

PT0048A

LQFP - 1.6 mm max height

LOW PROFILE QUAD FLATPACK



NOTES: (continued)

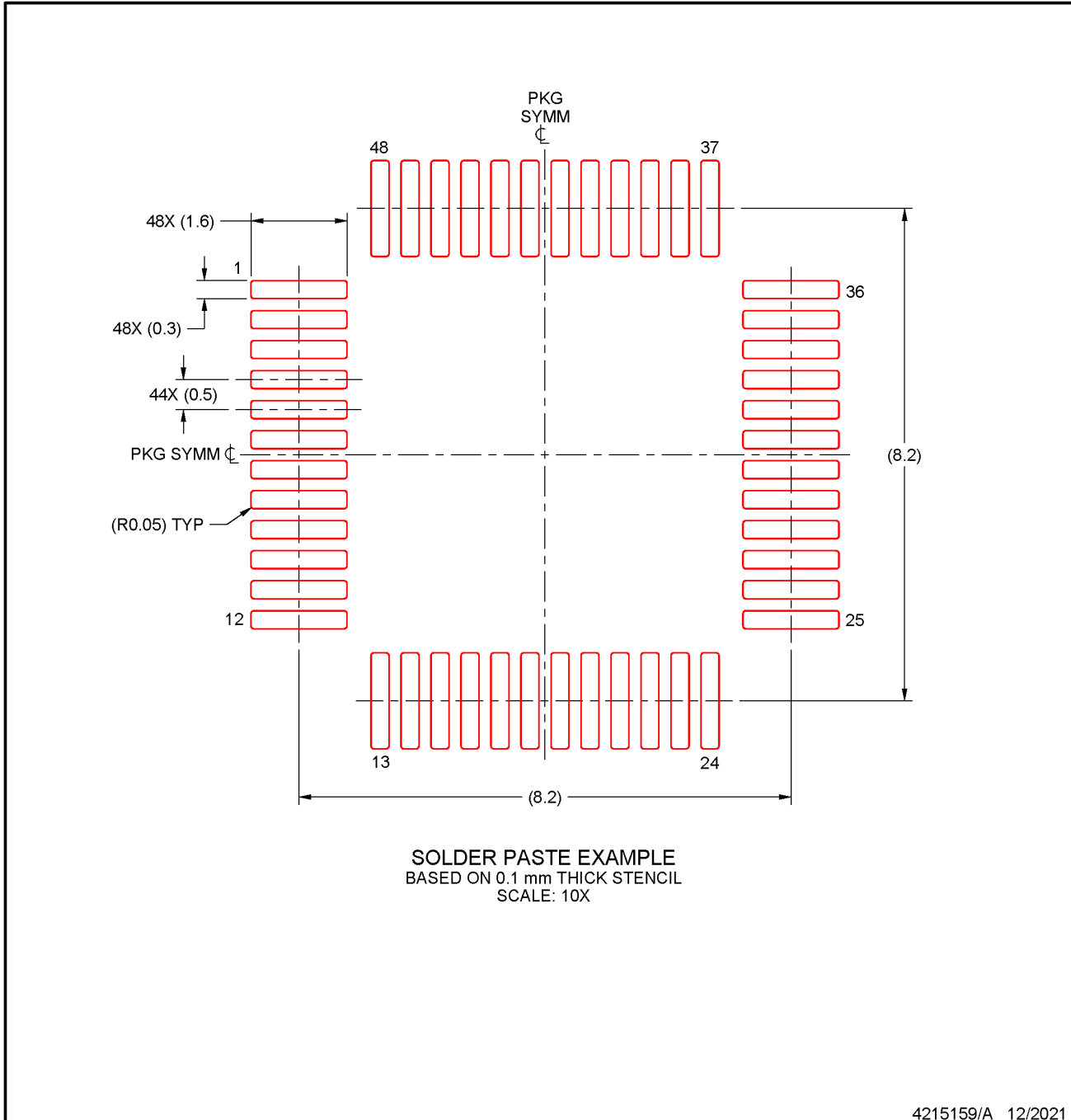
- 5. Publication IPC-7351 may have alternate designs.
- 6. Solder mask tolerances between and around signal pads can vary based on board fabrication site.

## EXAMPLE STENCIL DESIGN

**PT0048A**

**LQFP - 1.6 mm max height**

LOW PROFILE QUAD FLATPACK



NOTES: (continued)

7. Laser cutting apertures with trapezoidal walls and rounded corners may offer better paste release. IPC-7525 may have alternate design recommendations.
8. Board assembly site may have different recommendations for stencil design.

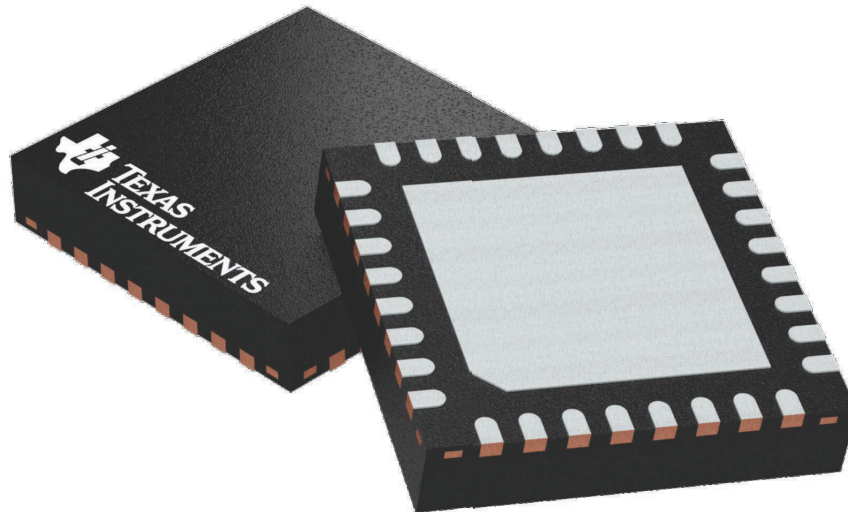
## GENERIC PACKAGE VIEW

**RHB 32**

5 x 5, 0.5 mm pitch

**VQFN - 1 mm max height**

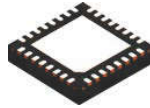
PLASTIC QUAD FLATPACK - NO LEAD



Images above are just a representation of the package family, actual package may vary.  
Refer to the product data sheet for package details.

4224745/A

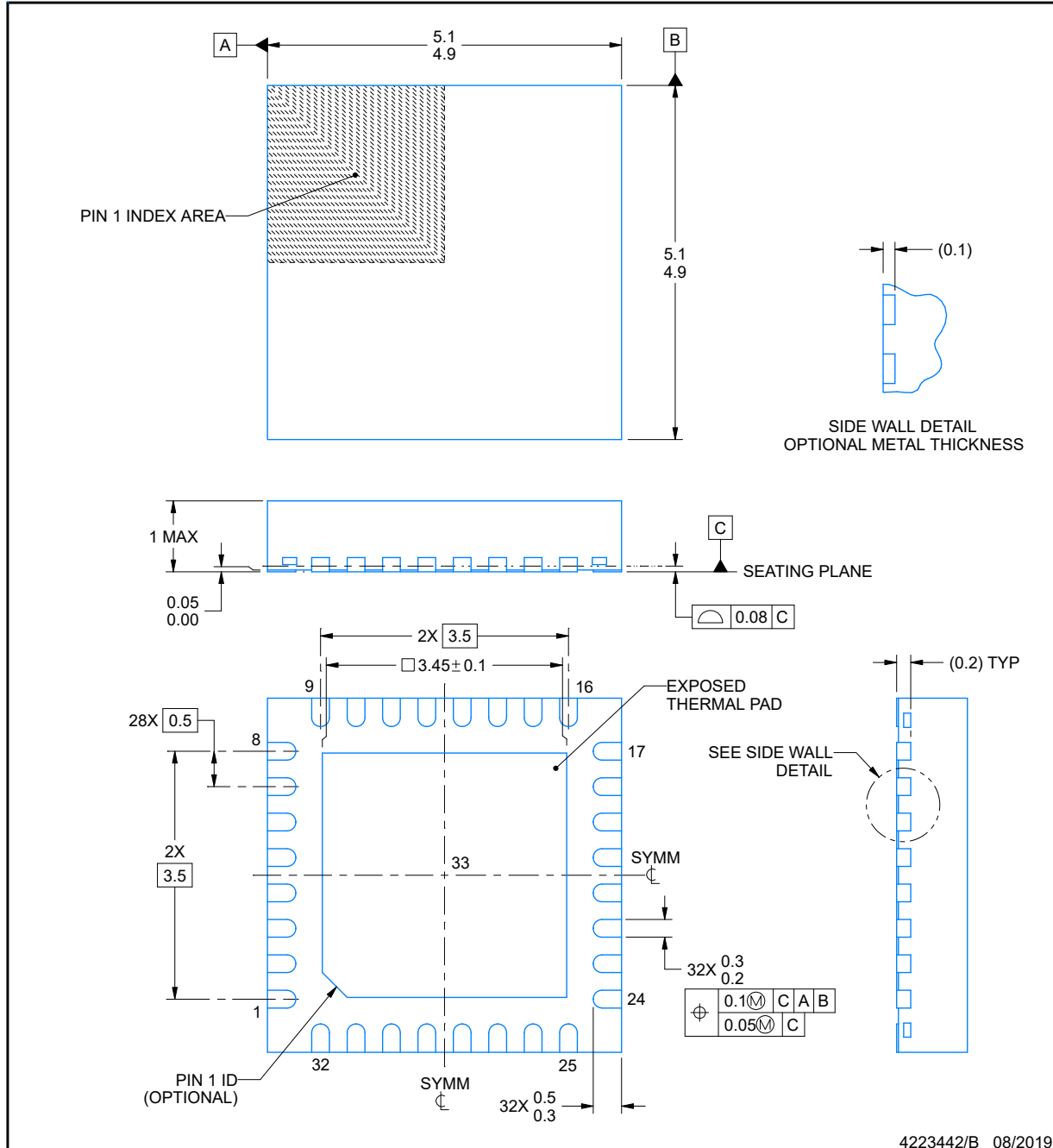
# RHB0032E



## PACKAGE OUTLINE

### VQFN - 1 mm max height

PLASTIC QUAD FLATPACK - NO LEAD



**NOTES:**

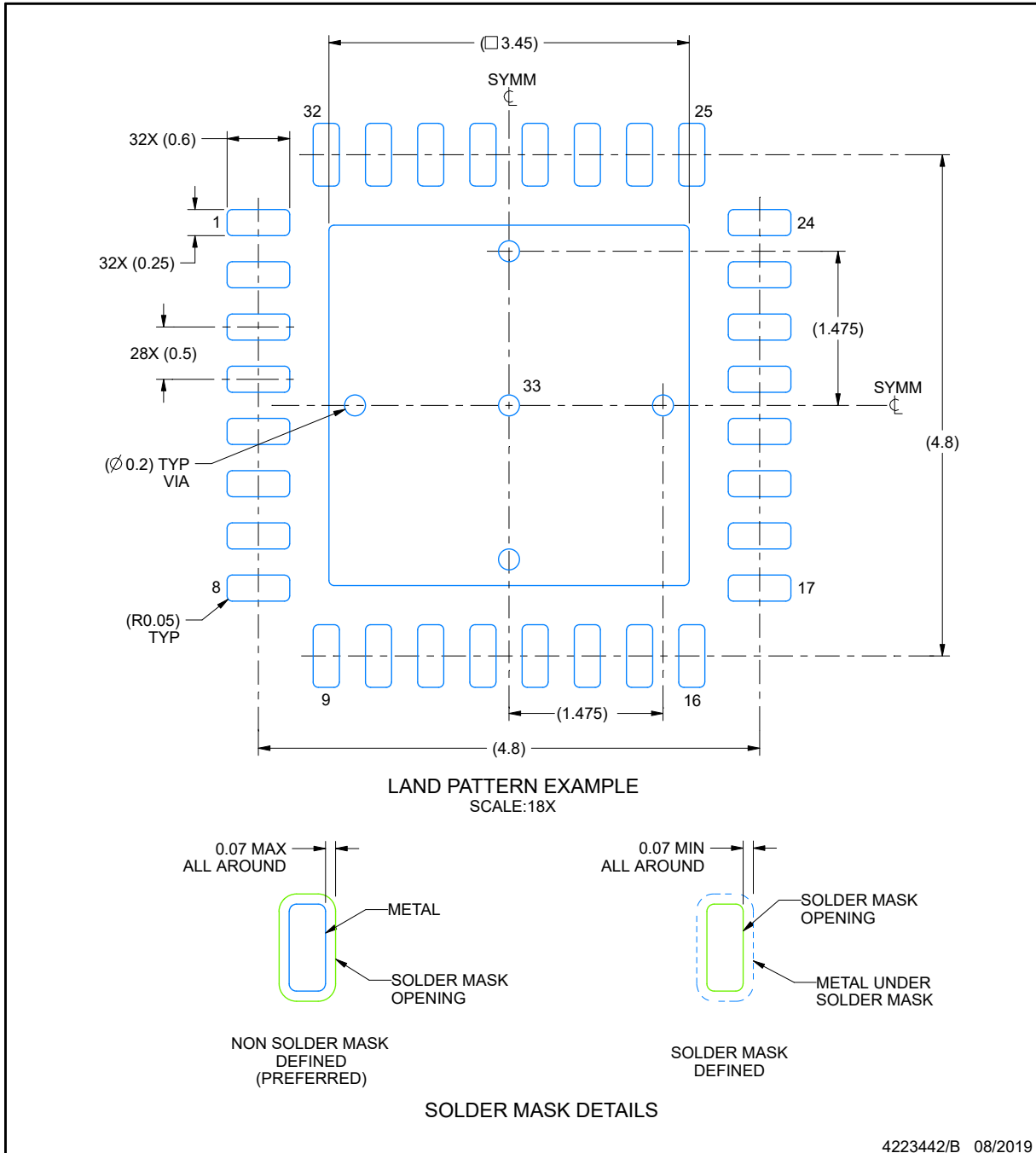
1. All linear dimensions are in millimeters. Any dimensions in parenthesis are for reference only. Dimensioning and tolerancing per ASME Y14.5M.
2. This drawing is subject to change without notice.
3. The package thermal pad must be soldered to the printed circuit board for thermal and mechanical performance.

## EXAMPLE BOARD LAYOUT

**RHB0032E**

**VQFN - 1 mm max height**

PLASTIC QUAD FLATPACK - NO LEAD



NOTES: (continued)

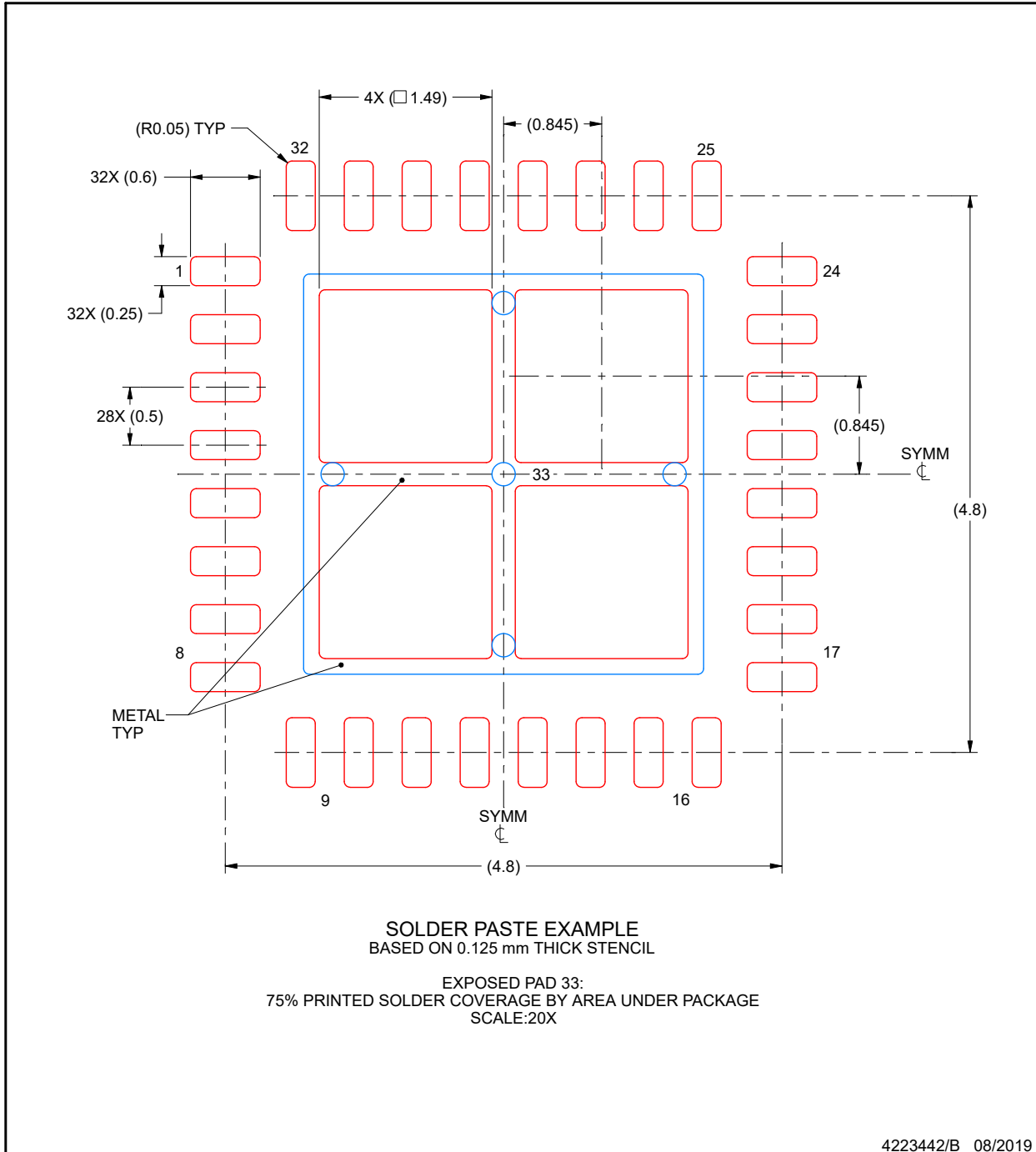
4. This package is designed to be soldered to a thermal pad on the board. For more information, see Texas Instruments literature number SLUA271 ([www.ti.com/lit/slua271](http://www.ti.com/lit/slua271)).
5. Vias are optional depending on application, refer to device data sheet. If any vias are implemented, refer to their locations shown on this view. It is recommended that vias under paste be filled, plugged or tented.

## EXAMPLE STENCIL DESIGN

**RHB0032E**

**VQFN - 1 mm max height**

PLASTIC QUAD FLATPACK - NO LEAD



NOTES: (continued)

6. Laser cutting apertures with trapezoidal walls and rounded corners may offer better paste release. IPC-7525 may have alternate design recommendations.

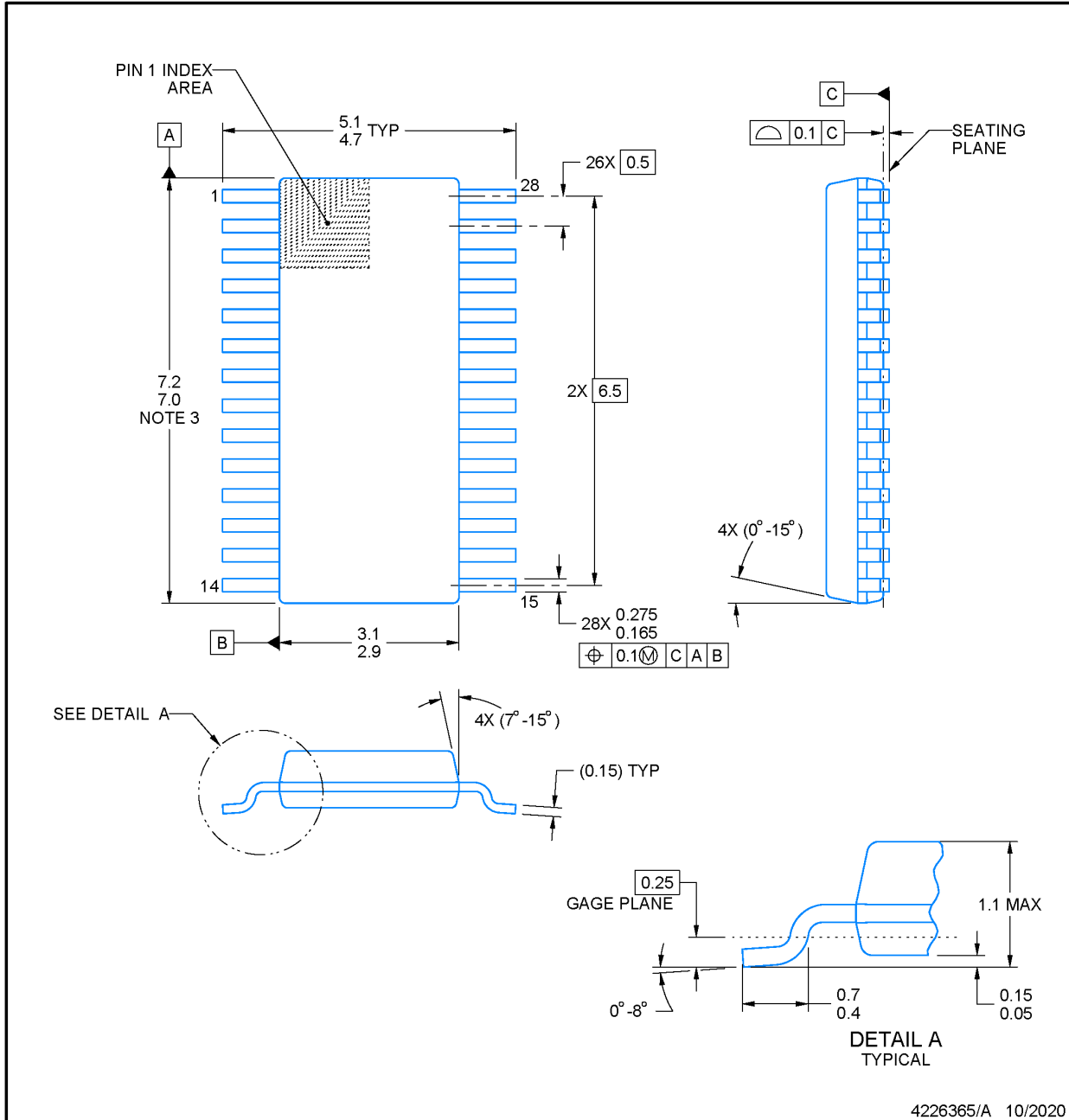


## PACKAGE OUTLINE

**DGS0028A**

**VSSOP - 1.1 mm max height**

SMALL OUTLINE PACKAGE



**NOTES:**

PowerPAD is a trademark of Texas Instruments.

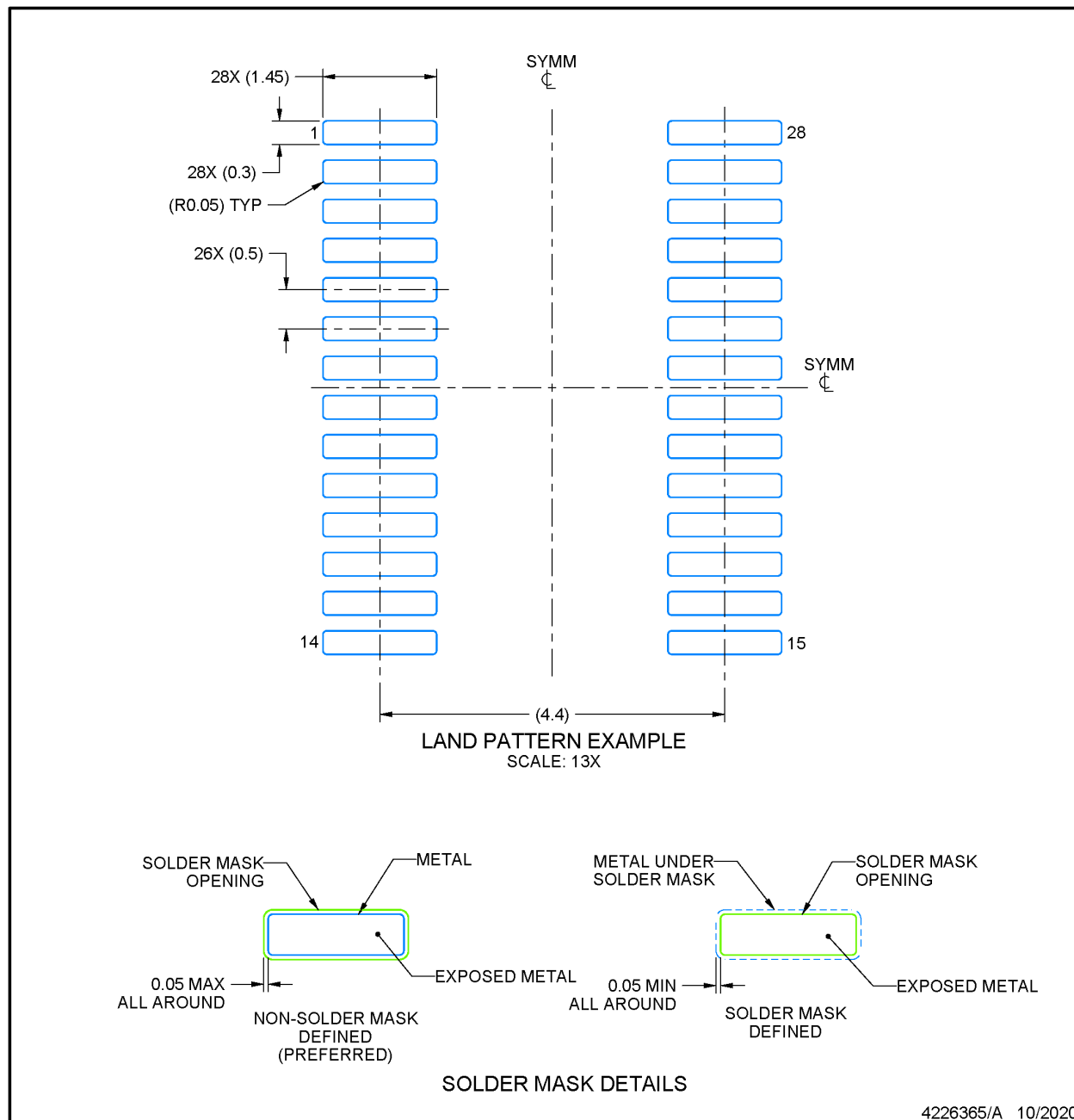
1. All linear dimensions are in millimeters. Any dimensions in parenthesis are for reference only. Dimensioning and tolerancing per ASME Y14.5M.
2. This drawing is subject to change without notice.
3. This dimension does not include mold flash, protrusions, or gate burrs. Mold flash, protrusions, or gate burrs shall not exceed 0.15 mm per side.
4. No JEDEC registration as of September 2020.
5. Features may differ or may not be present.

## EXAMPLE BOARD LAYOUT

### DGS0028A

### VSSOP - 1.1 mm max height

SMALL OUTLINE PACKAGE



4226365/A 10/2020

NOTES: (continued)

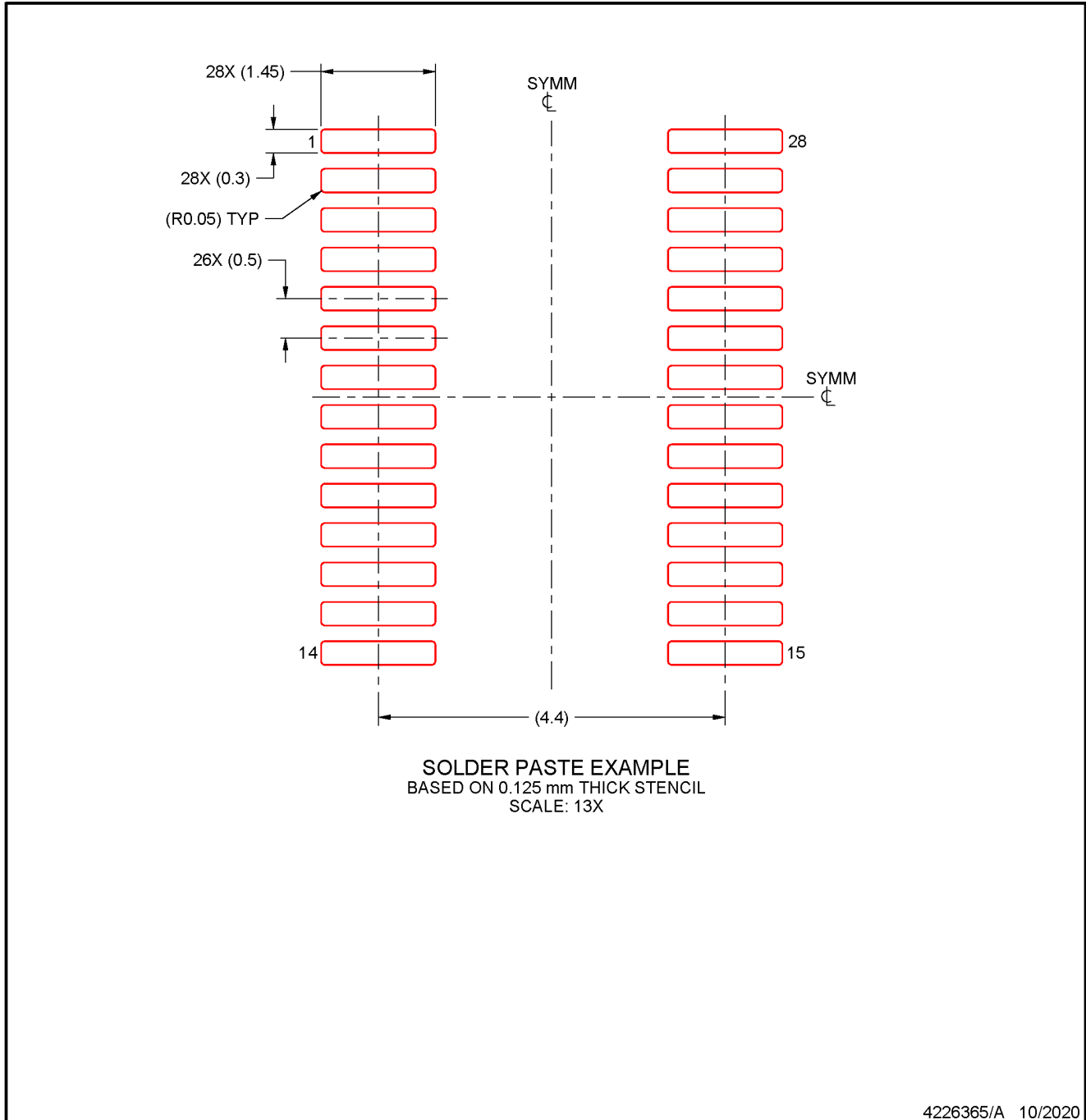
6. Publication IPC-7351 may have alternate designs.
7. Solder mask tolerances between and around signal pads can vary based on board fabrication site.
8. This package is designed to be soldered to a thermal pad on the board. For more information, see Texas Instruments literature numbers SLMA002 ([www.ti.com/lit/slma002](http://www.ti.com/lit/slma002)) and SLMA004 ([www.ti.com/lit/slma004](http://www.ti.com/lit/slma004)).
9. Size of metal pad may vary due to creepage requirement.
10. Vias are optional depending on application, refer to device data sheet. It is recommended that vias under paste be filled, plugged or tented.

## EXAMPLE STENCIL DESIGN

**DGS0028A**

**VSSOP - 1.1 mm max height**

SMALL OUTLINE PACKAGE



NOTES: (continued)

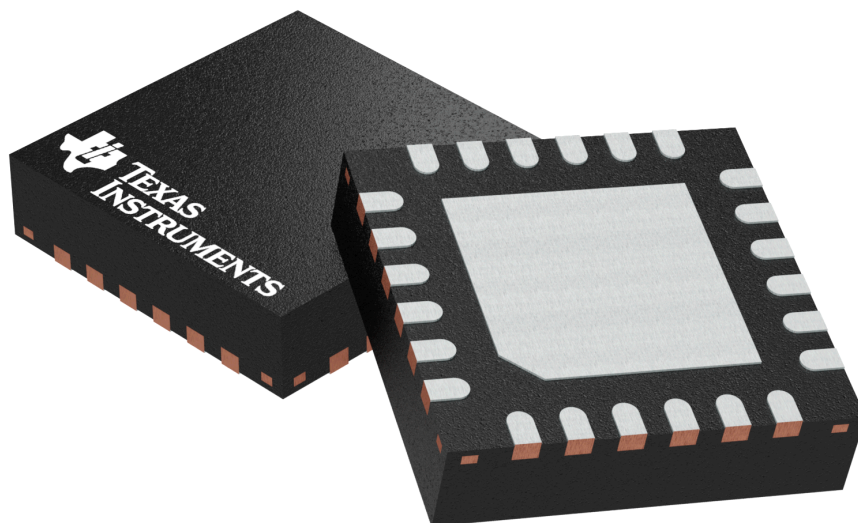
11. Laser cutting apertures with trapezoidal walls and rounded corners may offer better paste release. IPC-7525 may have alternate design recommendations.
12. Board assembly site may have different recommendations for stencil design.

**RGE 24**

**GENERIC PACKAGE VIEW**

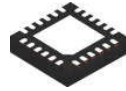
**VQFN - 1 mm max height**

PLASTIC QUAD FLATPACK - NO LEAD



Images above are just a representation of the package family, actual package may vary.  
Refer to the product data sheet for package details.

4204104/H

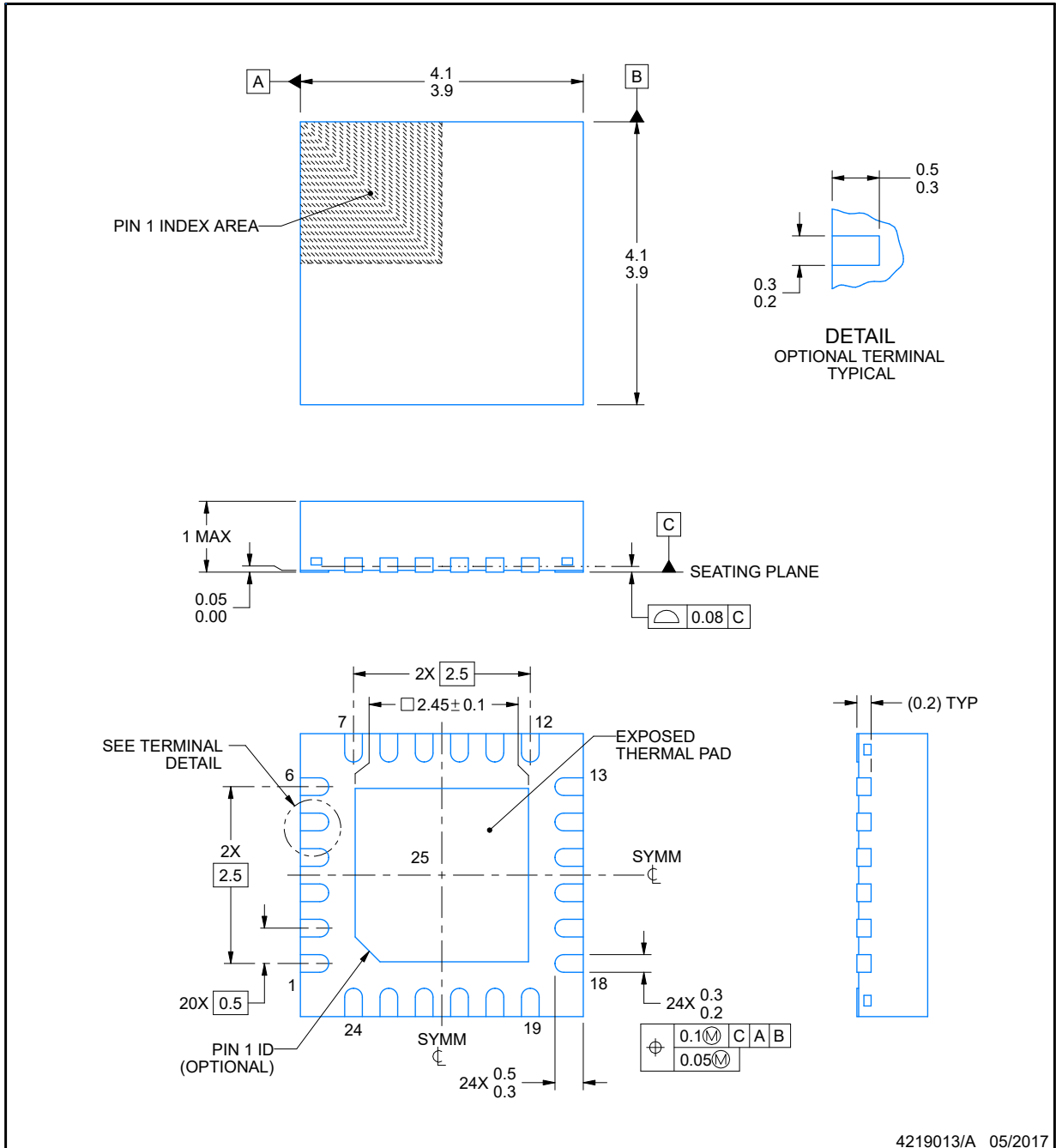


# RGE0024B

# PACKAGE OUTLINE

## VQFN - 1 mm max height

PLASTIC QUAD FLATPACK - NO LEAD



**NOTES:**

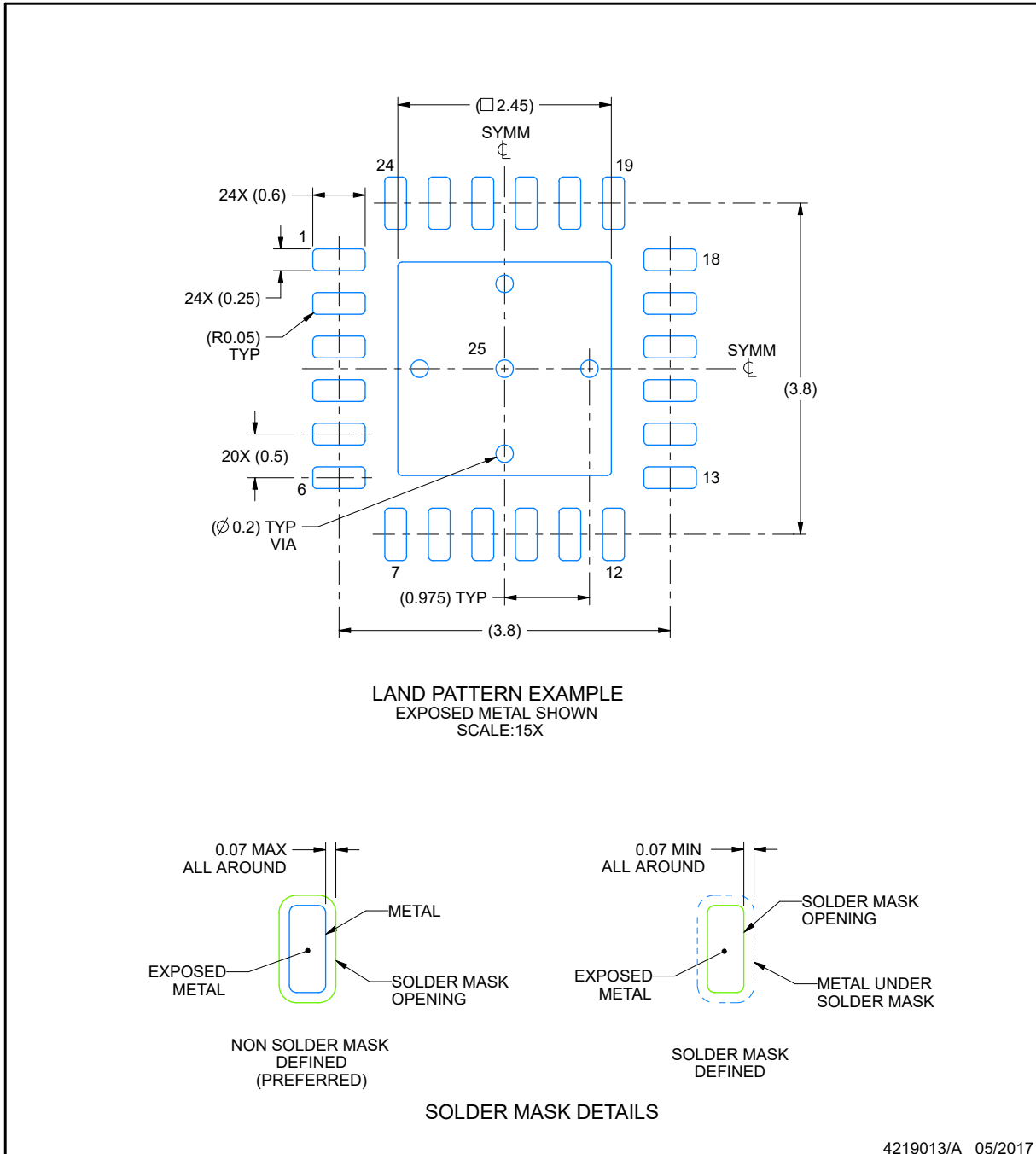
1. All linear dimensions are in millimeters. Any dimensions in parenthesis are for reference only. Dimensioning and tolerancing per ASME Y14.5M.
2. This drawing is subject to change without notice.
3. The package thermal pad must be soldered to the printed circuit board for thermal and mechanical performance.

## EXAMPLE BOARD LAYOUT

**RGE0024B**

**VQFN - 1 mm max height**

PLASTIC QUAD FLATPACK - NO LEAD



NOTES: (continued)

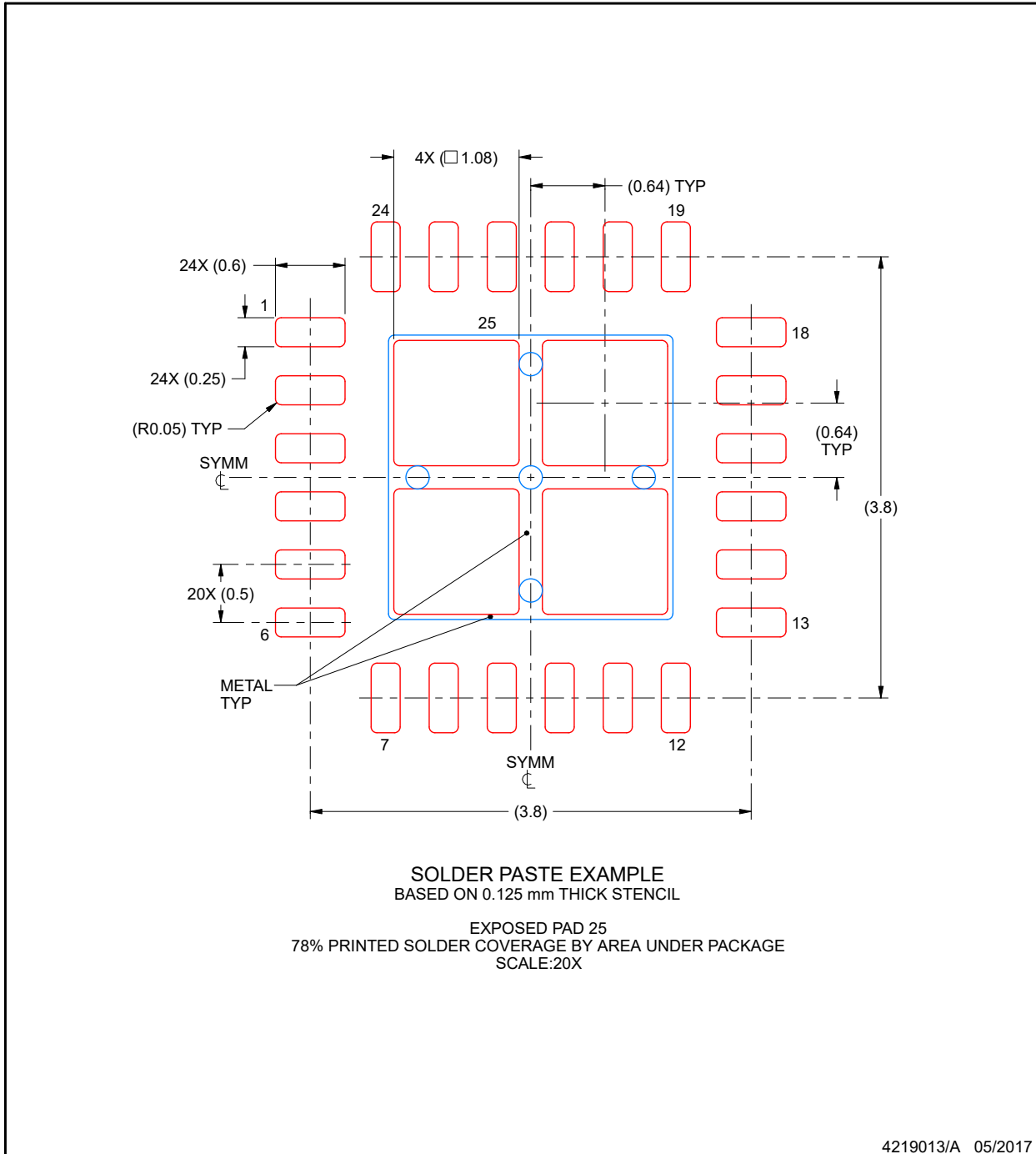
4. This package is designed to be soldered to a thermal pad on the board. For more information, see Texas Instruments literature number SLUA271 ([www.ti.com/lit/sluea271](http://www.ti.com/lit/sluea271)).
5. Vias are optional depending on application, refer to device data sheet. If any vias are implemented, refer to their locations shown on this view. It is recommended that vias under paste be filled, plugged or tented.

## EXAMPLE STENCIL DESIGN

**RGE0024B**

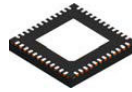
**VQFN - 1 mm max height**

PLASTIC QUAD FLATPACK - NO LEAD



NOTES: (continued)

6. Laser cutting apertures with trapezoidal walls and rounded corners may offer better paste release. IPC-7525 may have alternate design recommendations.

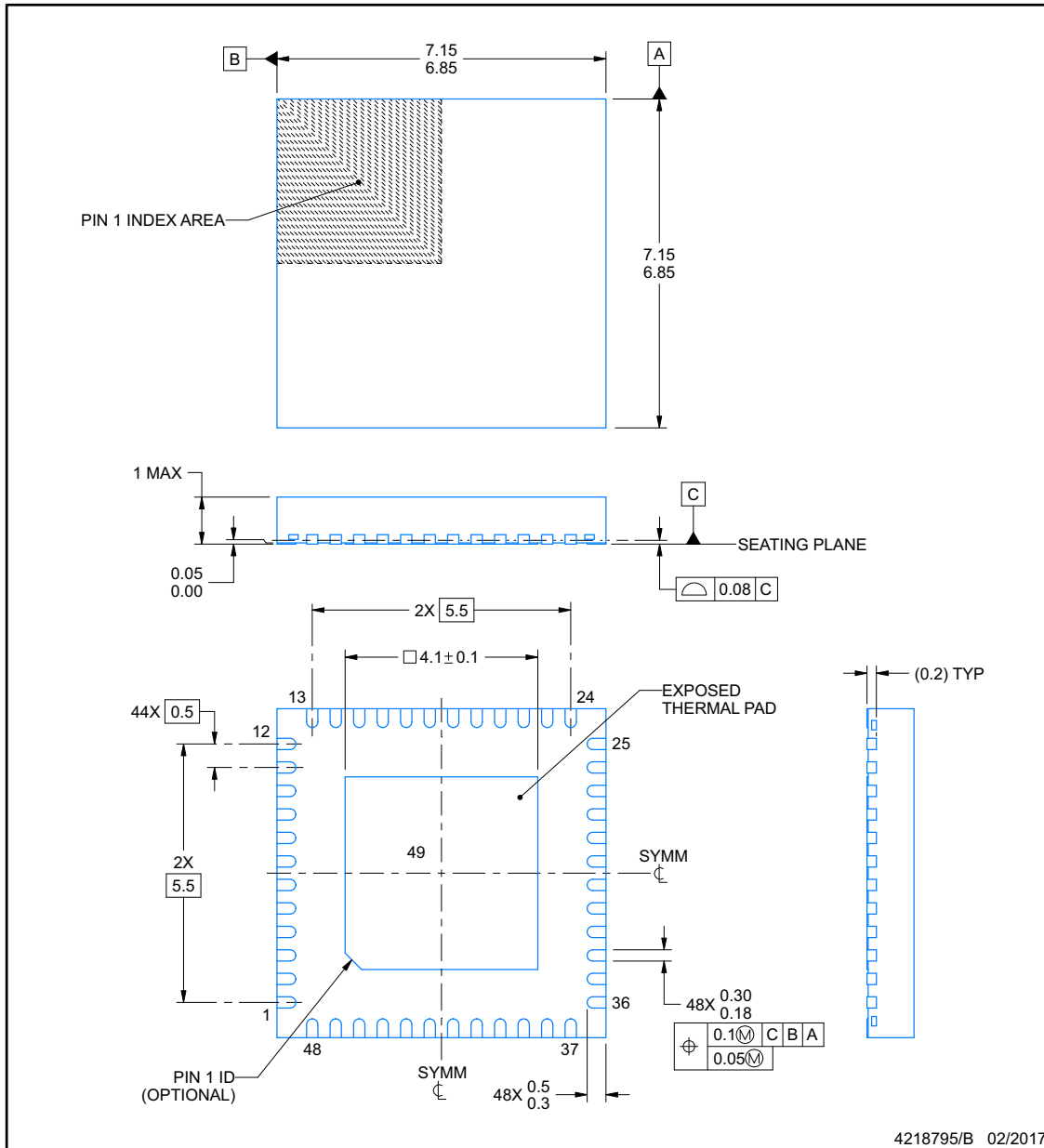


# RGZ0048B

# PACKAGE OUTLINE

## VQFN - 1 mm max height

PLASTIC QUAD FLATPACK - NO LEAD



4218795/B 02/2017

**NOTES:**

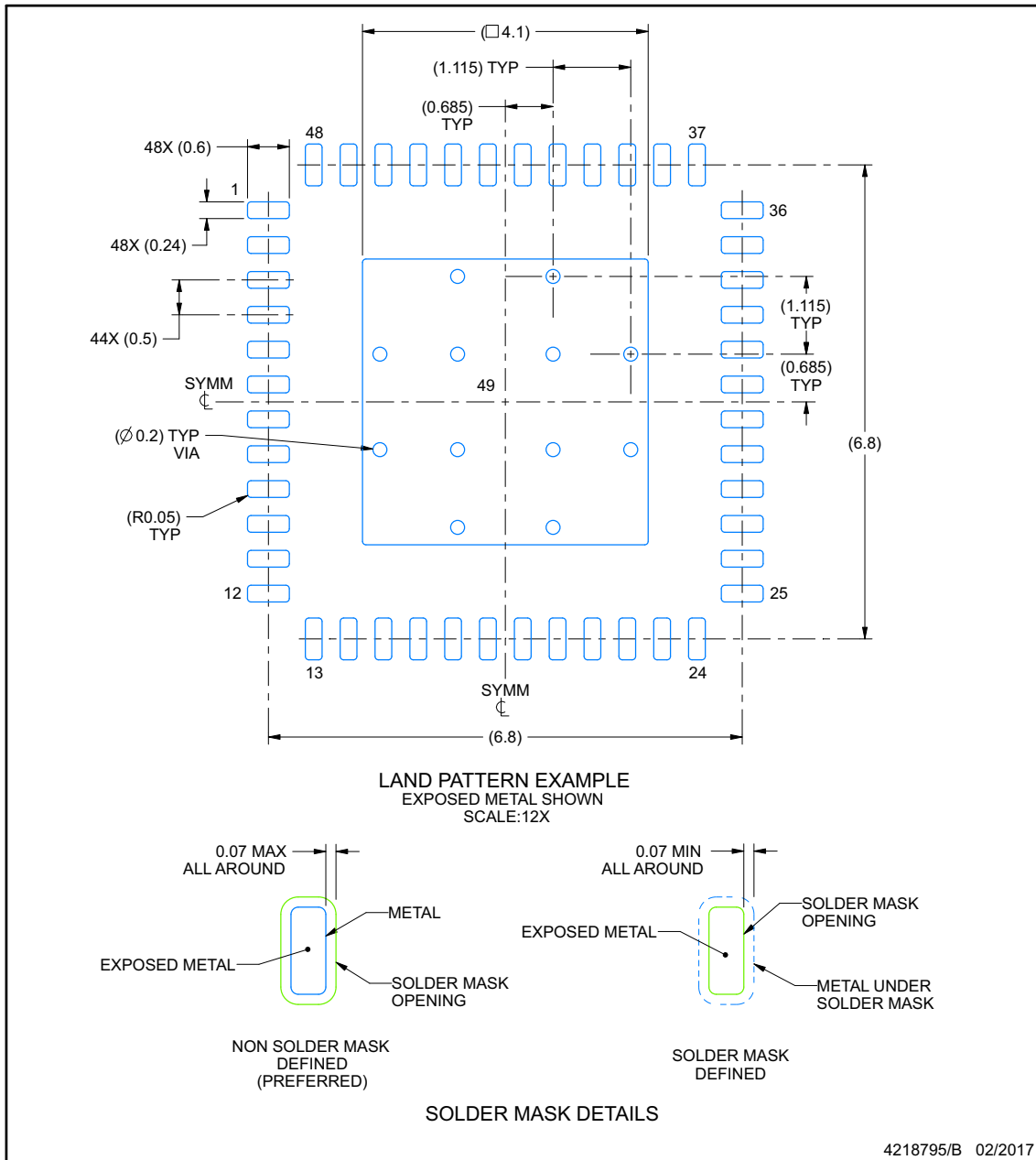
1. All linear dimensions are in millimeters. Any dimensions in parenthesis are for reference only. Dimensioning and tolerancing per ASME Y14.5M.
2. This drawing is subject to change without notice.
3. The package thermal pad must be soldered to the printed circuit board for thermal and mechanical performance.

**EXAMPLE BOARD LAYOUT**

**RGZ0048B**

**VQFN - 1 mm max height**

PLASTIC QUAD FLATPACK - NO LEAD



NOTES: (continued)

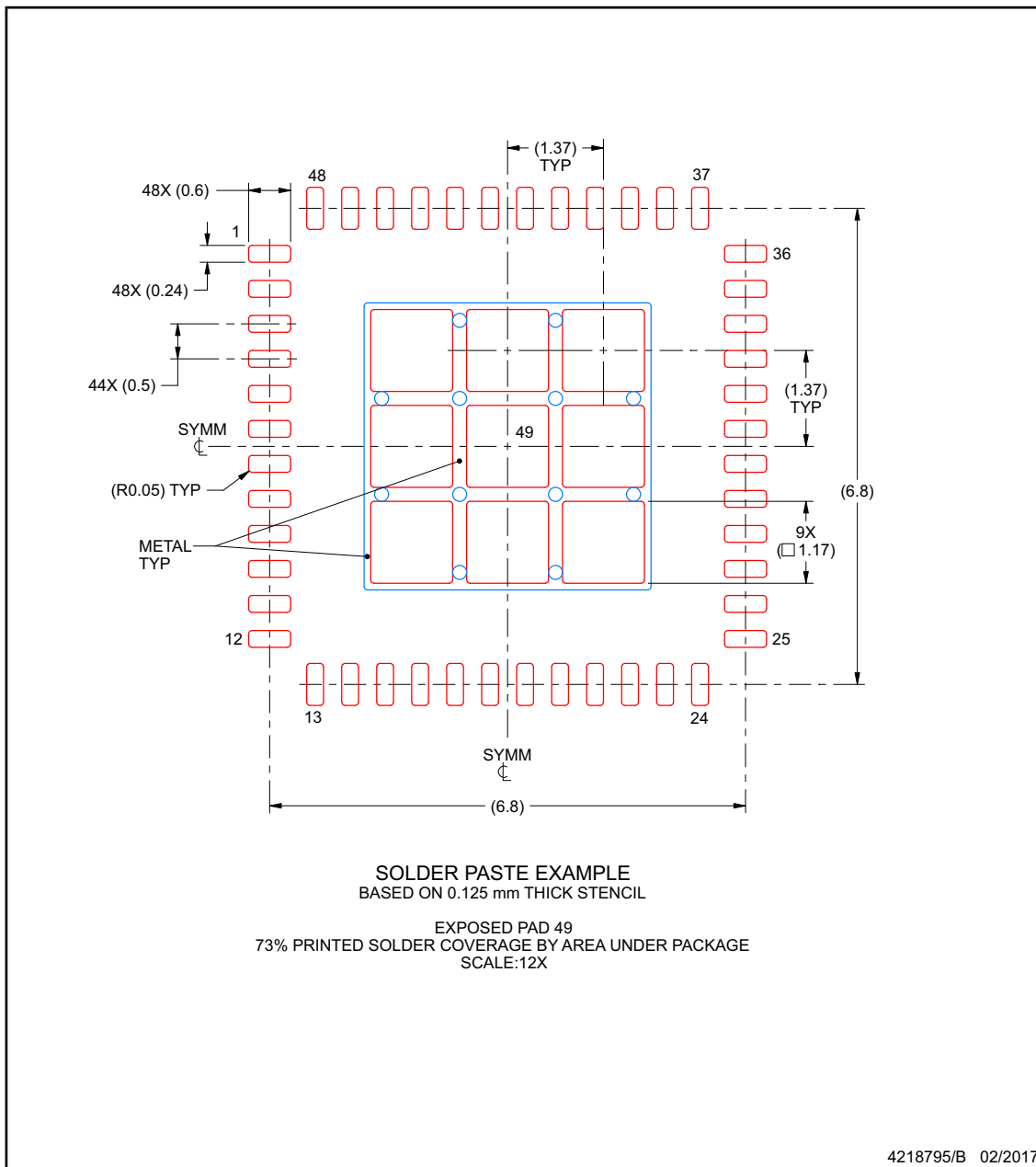
4. This package is designed to be soldered to a thermal pad on the board. For more information, see Texas Instruments literature number SLUA271 ([www.ti.com/lit/slua271](http://www.ti.com/lit/slua271)).
5. Vias are optional depending on application, refer to device data sheet. If any vias are implemented, refer to their locations shown on this view. It is recommended that vias under paste be filled, plugged or tented.

## EXAMPLE STENCIL DESIGN

**RGZ0048B**

**VQFN - 1 mm max height**

PLASTIC QUAD FLATPACK - NO LEAD



NOTES: (continued)

6. Laser cutting apertures with trapezoidal walls and rounded corners may offer better paste release. IPC-7525 may have alternate design recommendations.

**PACKAGING INFORMATION**

Orderable part number	Status (1)	Material type (2)	Package   Pins	Package qty   Carrier	RoHS (3)	Lead finish/ Ball material (4)	MSL rating/ Peak reflow (5)	Op temp (°C)	Part marking (6)
<a href="#">MSPM0L2116SRGZR</a>	Active	Production	VQFN (RGZ)   48	4000   LARGE T&R	Yes	NIPDAU	Level-2-260C-1 YEAR	-40 to 125	MSPM0 L2116S
<a href="#">MSPM0L2117SRGZR</a>	Active	Production	VQFN (RGZ)   48	4000   LARGE T&R	Yes	NIPDAU	Level-2-260C-1 YEAR	-40 to 125	MSPM0 L2117S

(1) **Status:** For more details on status, see our [product life cycle](#).

(2) **Material type:** When designated, preproduction parts are prototypes/experimental devices, and are not yet approved or released for full production. Testing and final process, including without limitation quality assurance, reliability performance testing, and/or process qualification, may not yet be complete, and this item is subject to further changes or possible discontinuation. If available for ordering, purchases will be subject to an additional waiver at checkout, and are intended for early internal evaluation purposes only. These items are sold without warranties of any kind.

(3) **RoHS values:** Yes, No, RoHS Exempt. See the [TI RoHS Statement](#) for additional information and value definition.

(4) **Lead finish/Ball material:** Parts may have multiple material finish options. Finish options are separated by a vertical ruled line. Lead finish/Ball material values may wrap to two lines if the finish value exceeds the maximum column width.

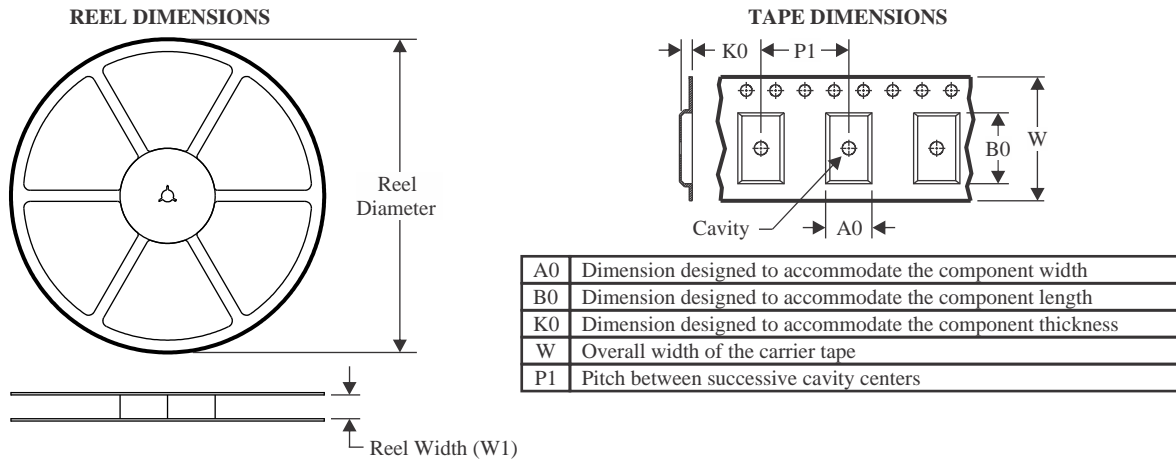
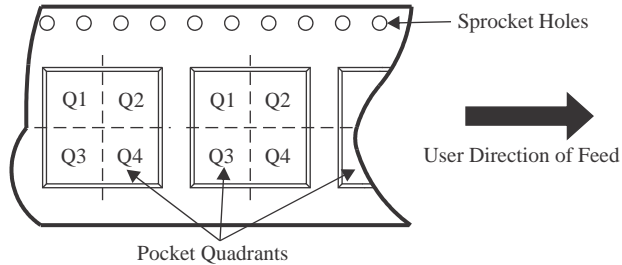
(5) **MSL rating/Peak reflow:** The moisture sensitivity level ratings and peak solder (reflow) temperatures. In the event that a part has multiple moisture sensitivity ratings, only the lowest level per JEDEC standards is shown. Refer to the shipping label for the actual reflow temperature that will be used to mount the part to the printed circuit board.

(6) **Part marking:** There may be an additional marking, which relates to the logo, the lot trace code information, or the environmental category of the part.

Multiple part markings will be inside parentheses. Only one part marking contained in parentheses and separated by a "-" will appear on a part. If a line is indented then it is a continuation of the previous line and the two combined represent the entire part marking for that device.

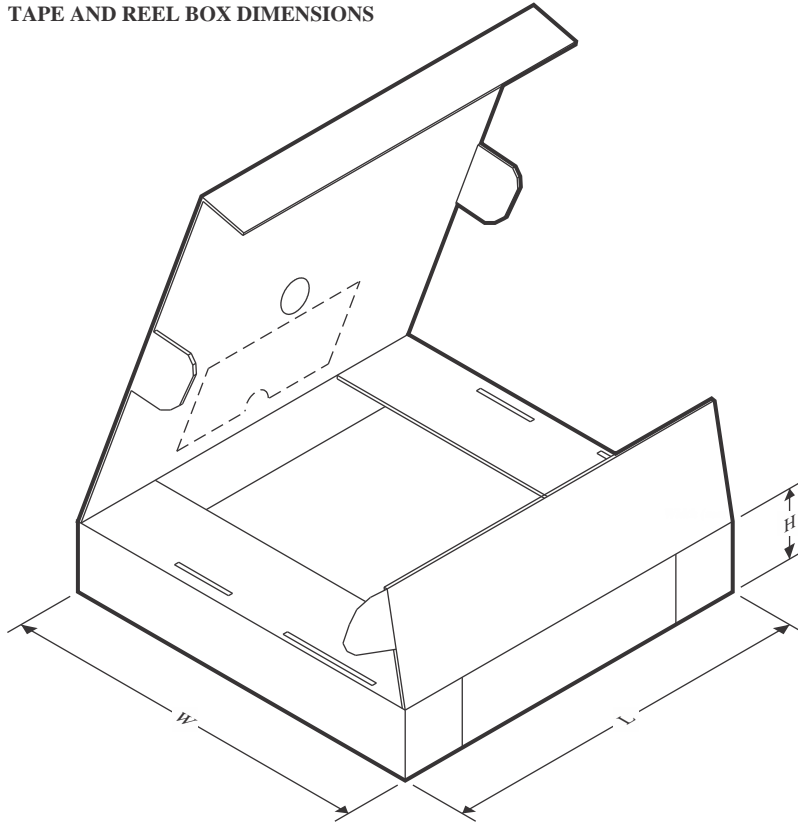
**Important Information and Disclaimer:** The information provided on this page represents TI's knowledge and belief as of the date that it is provided. TI bases its knowledge and belief on information provided by third parties, and makes no representation or warranty as to the accuracy of such information. Efforts are underway to better integrate information from third parties. TI has taken and continues to take reasonable steps to provide representative and accurate information but may not have conducted destructive testing or chemical analysis on incoming materials and chemicals. TI and TI suppliers consider certain information to be proprietary, and thus CAS numbers and other limited information may not be available for release.

In no event shall TI's liability arising out of such information exceed the total purchase price of the TI part(s) at issue in this document sold by TI to Customer on an annual basis.

**TAPE AND REEL INFORMATION**

**QUADRANT ASSIGNMENTS FOR PIN 1 ORIENTATION IN TAPE**


\*All dimensions are nominal

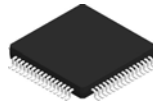
Device	Package Type	Package Drawing	Pins	SPQ	Reel Diameter (mm)	Reel Width W1 (mm)	A0 (mm)	B0 (mm)	K0 (mm)	P1 (mm)	W (mm)	Pin1 Quadrant
MSPM0L2116SRGZR	VQFN	RGZ	48	4000	330.0	16.4	7.3	7.3	1.1	12.0	16.0	Q2
MSPM0L2117SRGZR	VQFN	RGZ	48	4000	330.0	16.4	7.3	7.3	1.1	12.0	16.0	Q2

**TAPE AND REEL BOX DIMENSIONS**


\*All dimensions are nominal

Device	Package Type	Package Drawing	Pins	SPQ	Length (mm)	Width (mm)	Height (mm)
MSPM0L2116SRGZR	VQFN	RGZ	48	4000	360.0	360.0	36.0
MSPM0L2117SRGZR	VQFN	RGZ	48	4000	360.0	360.0	36.0

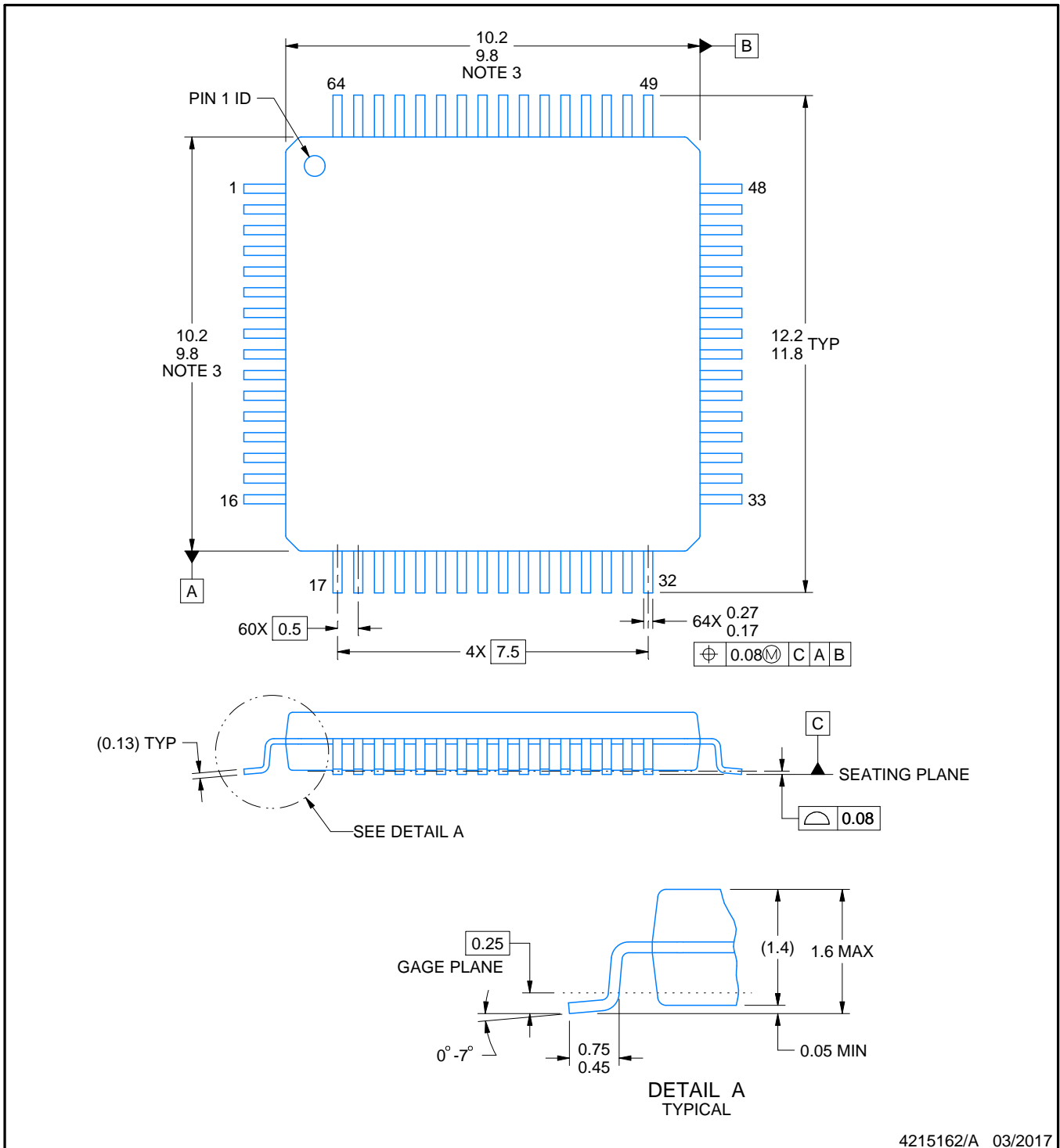
# PM0064A



# PACKAGE OUTLINE

LQFP - 1.6 mm max height

PLASTIC QUAD FLATPACK



4215162/A 03/2017

**NOTES:**

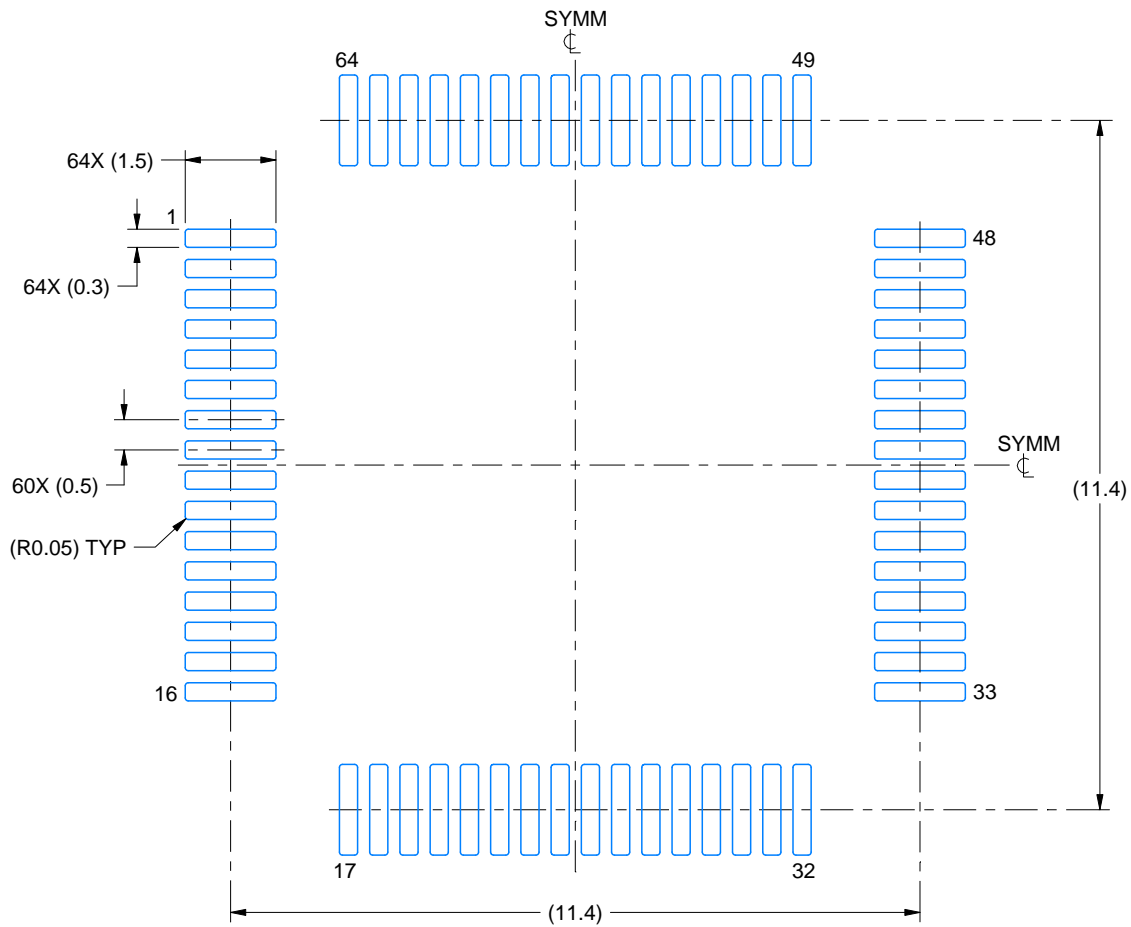
1. All linear dimensions are in millimeters. Any dimensions in parenthesis are for reference only. Dimensioning and tolerancing per ASME Y14.5M.
2. This drawing is subject to change without notice.
3. This dimension does not include mold flash, protrusions, or gate burrs. Mold flash, protrusions, or gate burrs shall not exceed 0.15 mm per side.
4. Reference JEDEC registration MS-026.

# EXAMPLE BOARD LAYOUT

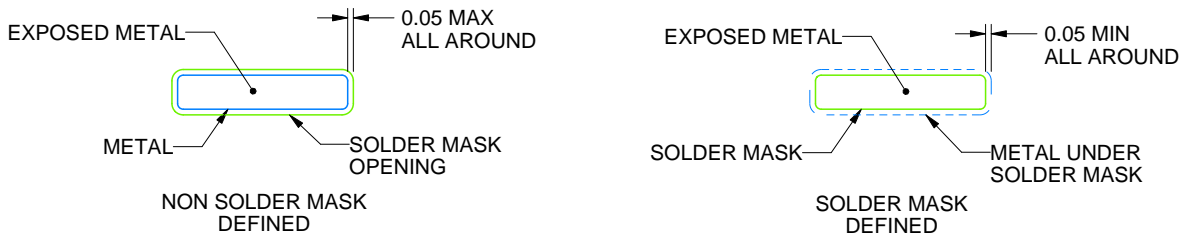
PM0064A

LQFP - 1.6 mm max height

PLASTIC QUAD FLATPACK



LAND PATTERN EXAMPLE  
EXPOSED METAL SHOWN  
SCALE:8X



SOLDER MASK DETAILS

4215162/A 03/2017

NOTES: (continued)

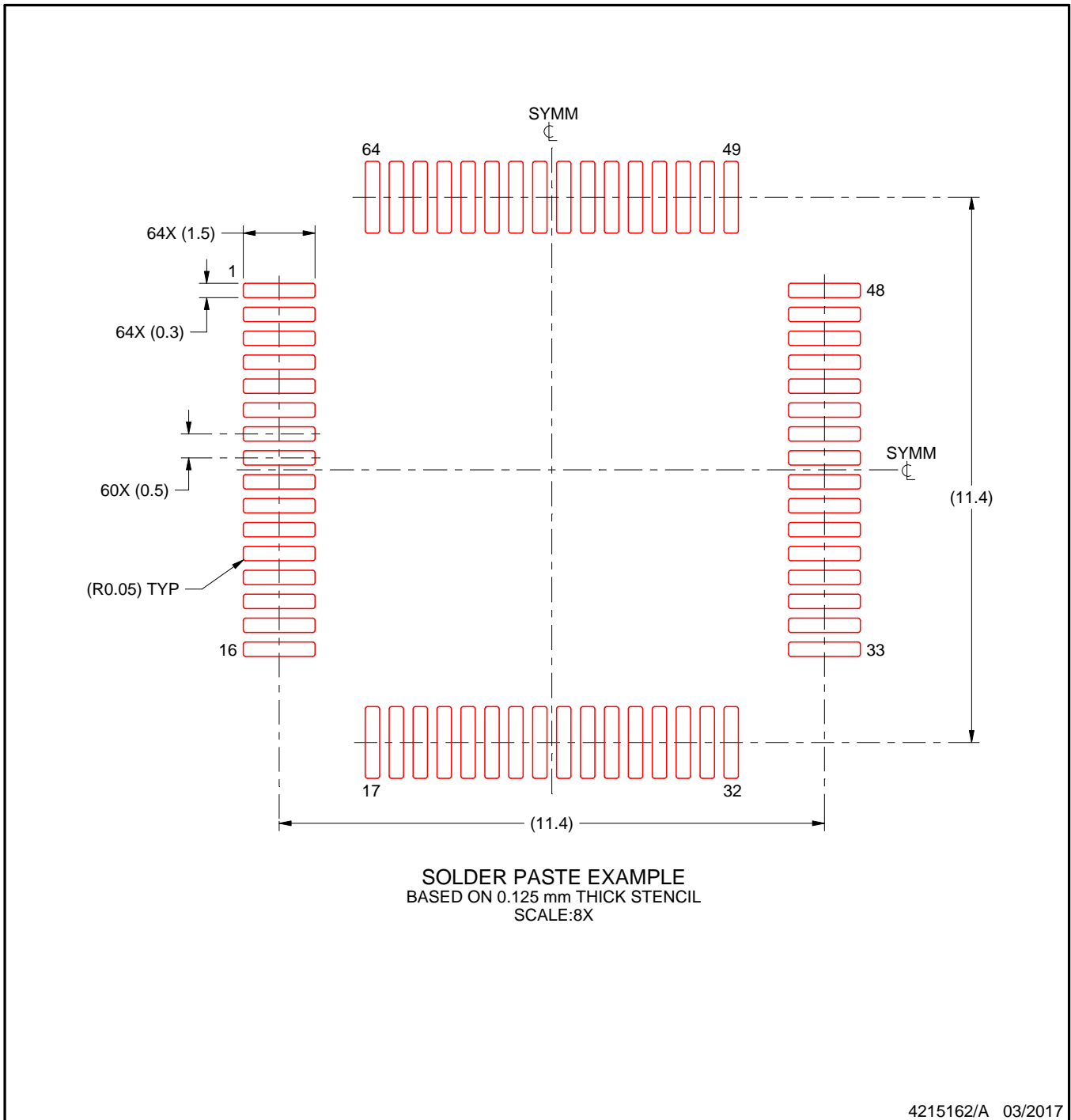
5. Publication IPC-7351 may have alternate designs.
6. Solder mask tolerances between and around signal pads can vary based on board fabrication site.
7. For more information, see Texas Instruments literature number SLMA004 ([www.ti.com/lit/slma004](http://www.ti.com/lit/slma004)).

# EXAMPLE STENCIL DESIGN

PM0064A

LQFP - 1.6 mm max height

PLASTIC QUAD FLATPACK



NOTES: (continued)

- 8. Laser cutting apertures with trapezoidal walls and rounded corners may offer better paste release. IPC-7525 may have alternate design recommendations.
- 9. Board assembly site may have different recommendations for stencil design.

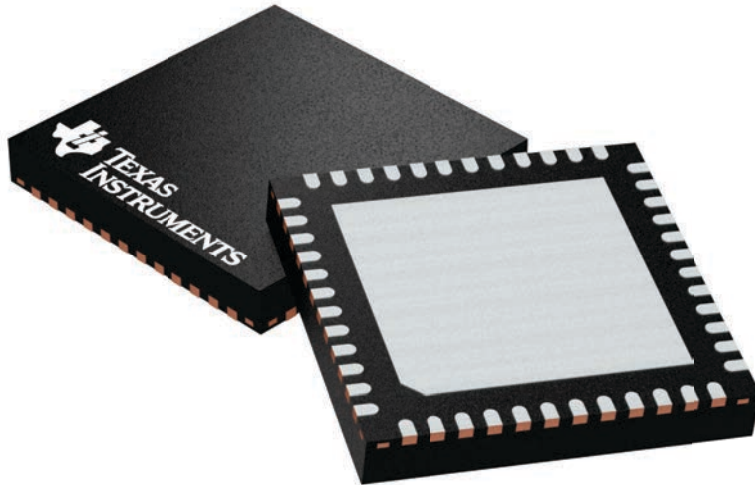
## GENERIC PACKAGE VIEW

**RGZ 48**

**VQFN - 1 mm max height**

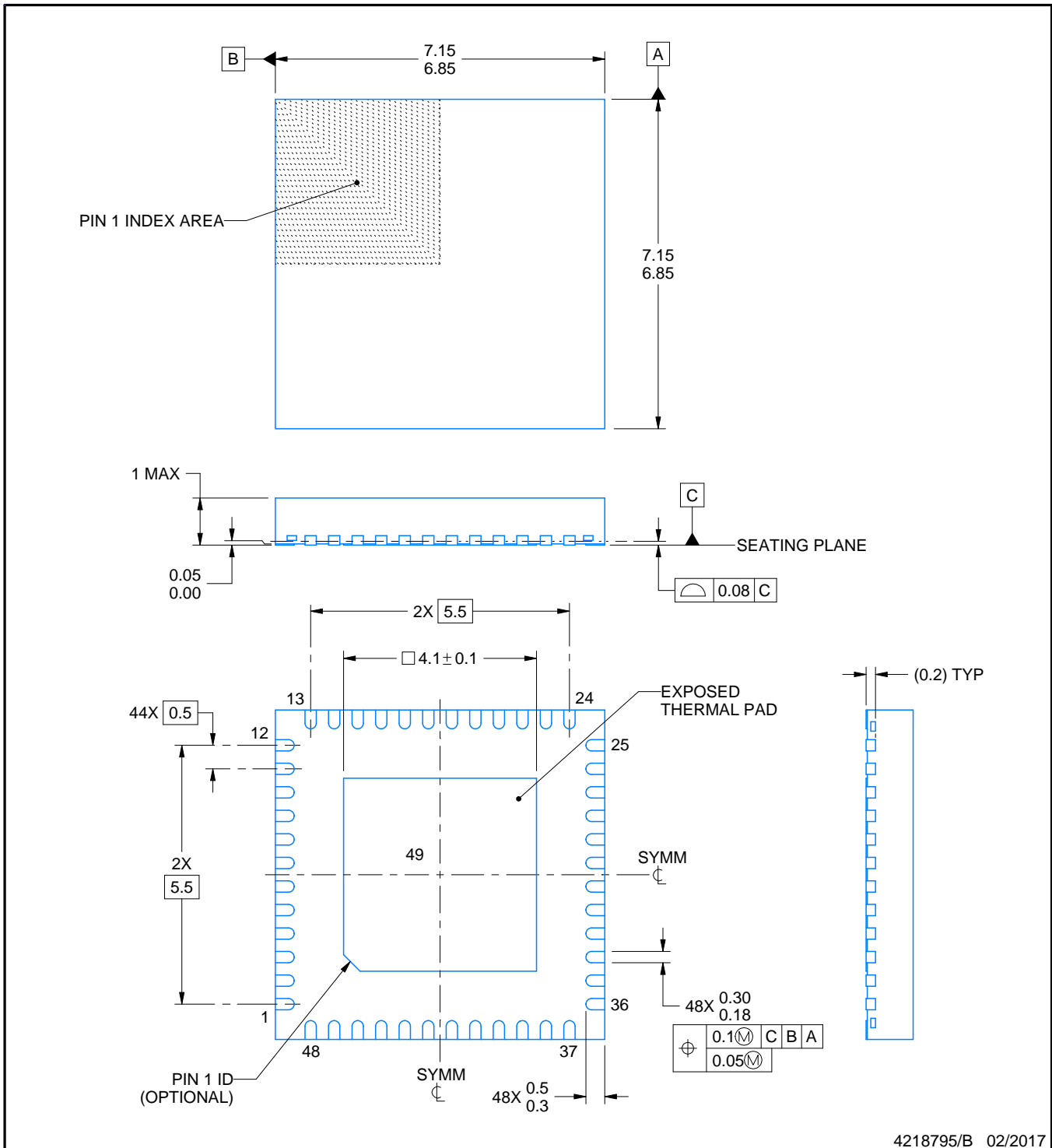
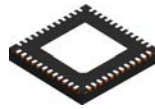
7 x 7, 0.5 mm pitch

PLASTIC QUADFLAT PACK- NO LEAD



Images above are just a representation of the package family, actual package may vary.  
Refer to the product data sheet for package details.

4224671/A



4218795/B 02/2017

NOTES:

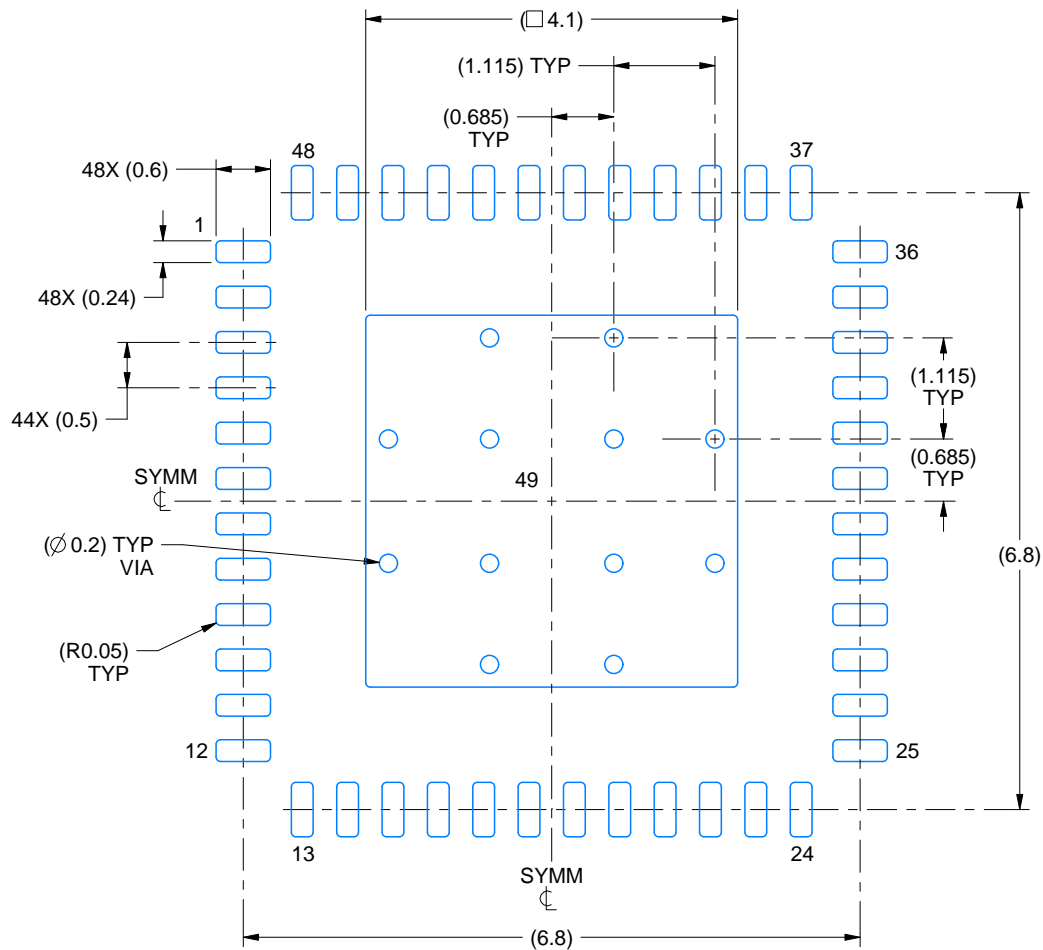
1. All linear dimensions are in millimeters. Any dimensions in parenthesis are for reference only. Dimensioning and tolerancing per ASME Y14.5M.
2. This drawing is subject to change without notice.
3. The package thermal pad must be soldered to the printed circuit board for thermal and mechanical performance.

# EXAMPLE BOARD LAYOUT

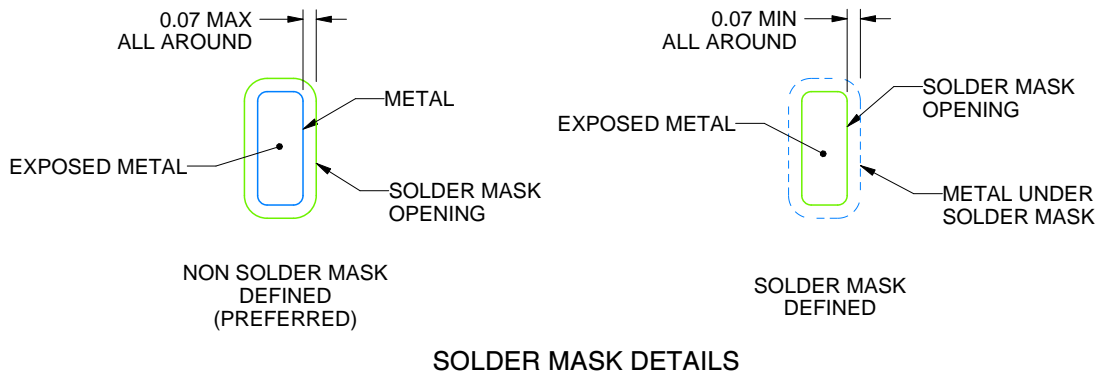
**RGZ0048B**

**VQFN - 1 mm max height**

PLASTIC QUAD FLATPACK - NO LEAD



**LAND PATTERN EXAMPLE**  
EXPOSED METAL SHOWN  
SCALE:12X



**SOLDER MASK DETAILS**

4218795/B 02/2017

NOTES: (continued)

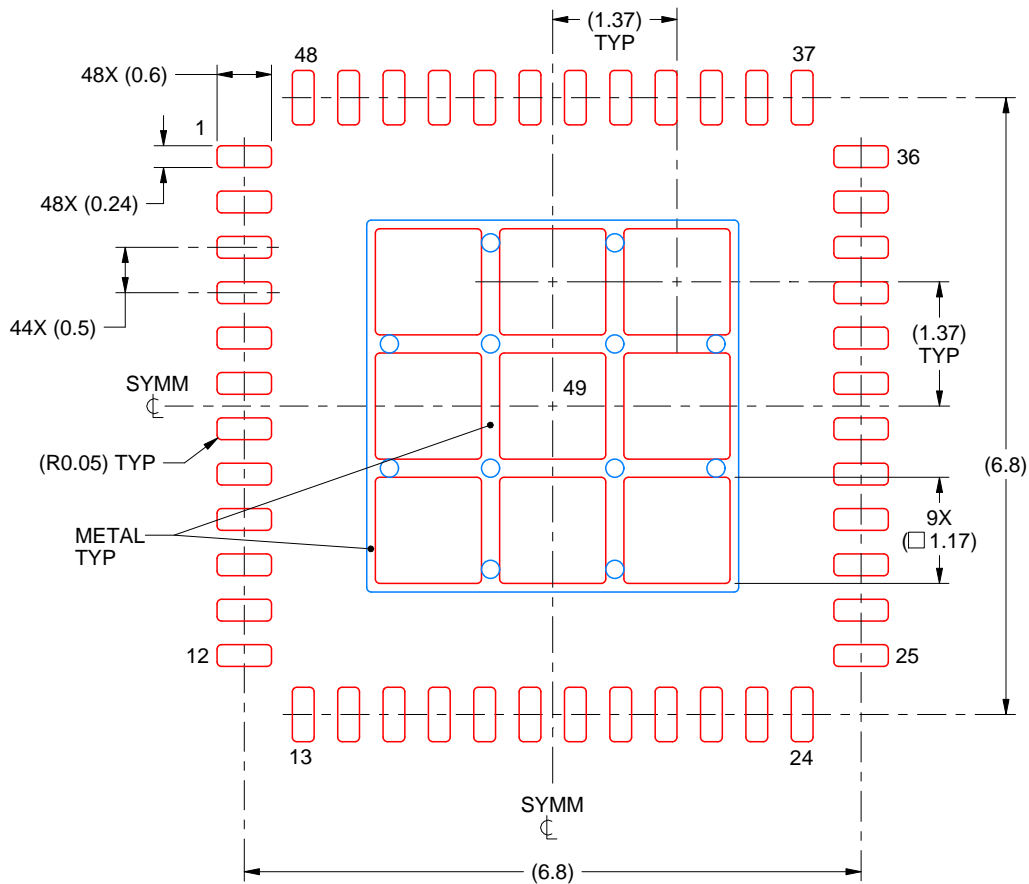
4. This package is designed to be soldered to a thermal pad on the board. For more information, see Texas Instruments literature number SLUA271 ([www.ti.com/lit/slua271](http://www.ti.com/lit/slua271)).
5. Vias are optional depending on application, refer to device data sheet. If any vias are implemented, refer to their locations shown on this view. It is recommended that vias under paste be filled, plugged or tented.

# EXAMPLE STENCIL DESIGN

RGZ0048B

VQFN - 1 mm max height

PLASTIC QUAD FLATPACK - NO LEAD



**SOLDER PASTE EXAMPLE**  
 BASED ON 0.125 mm THICK STENCIL

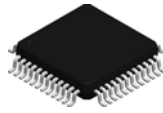
EXPOSED PAD 49  
 73% PRINTED SOLDER COVERAGE BY AREA UNDER PACKAGE  
 SCALE:12X

4218795/B 02/2017

NOTES: (continued)

- 6. Laser cutting apertures with trapezoidal walls and rounded corners may offer better paste release. IPC-7525 may have alternate design recommendations.

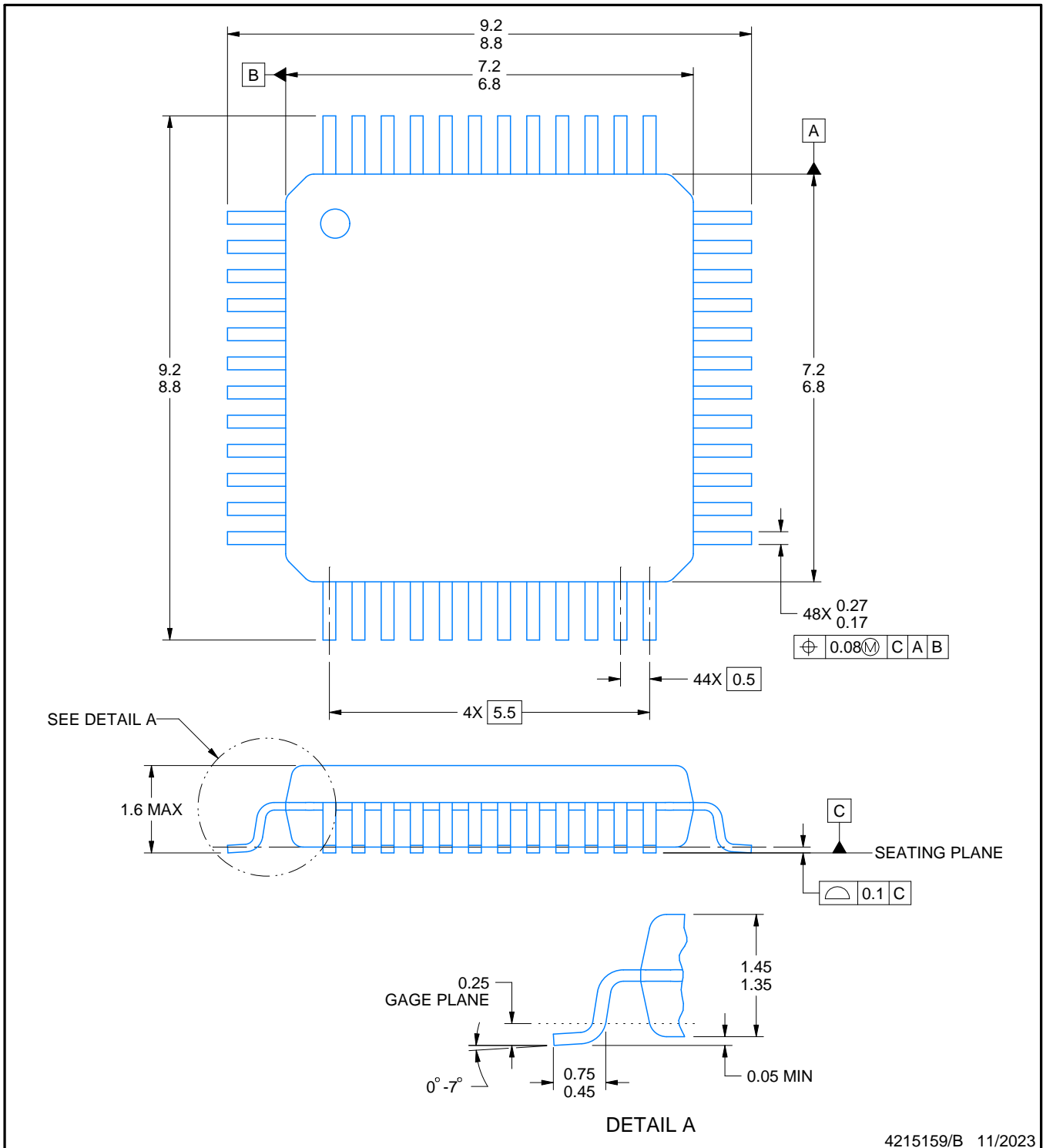
PT0048A



# PACKAGE OUTLINE

LQFP - 1.6 mm max height

LOW PROFILE QUAD FLATPACK



NOTES:

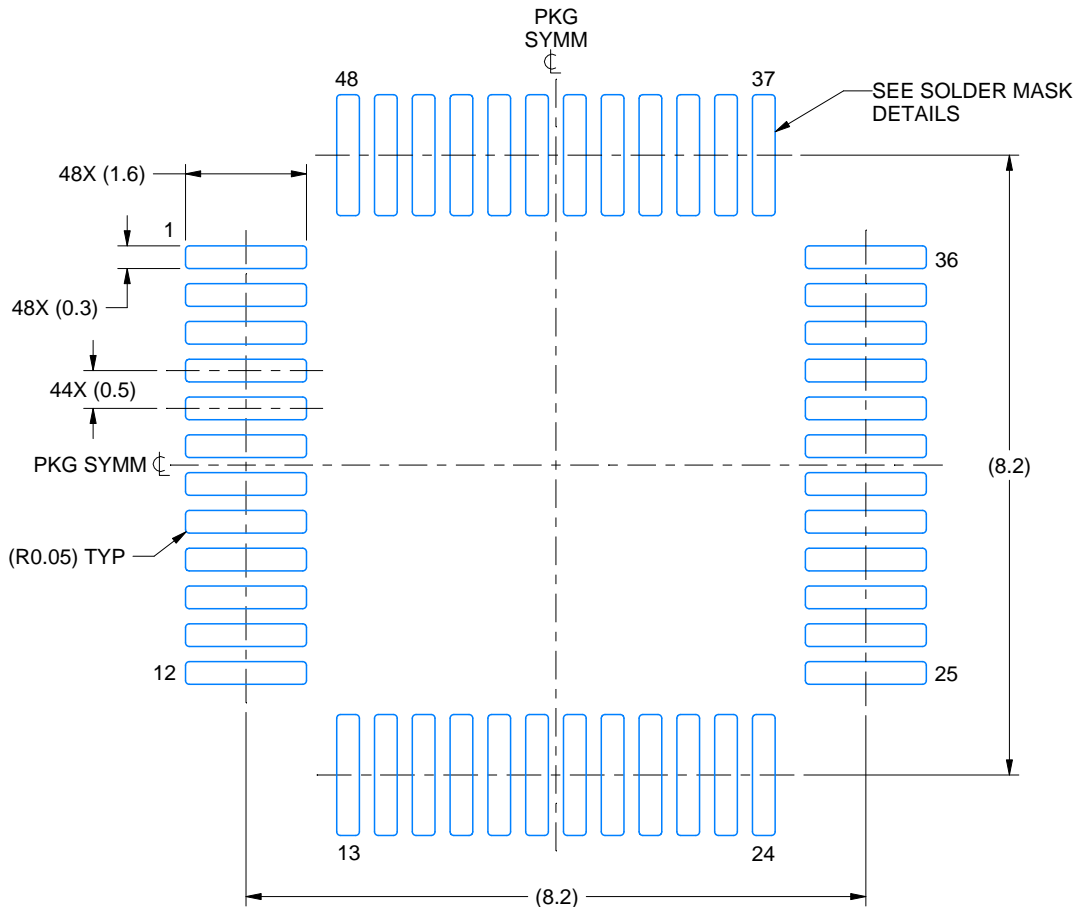
1. All linear dimensions are in millimeters. Any dimensions in parenthesis are for reference only. Dimensioning and tolerancing per ASME Y14.5M.
2. This drawing is subject to change without notice.
3. Reference JEDEC registration MS-026.
4. This may also be a thermally enhanced plastic package with leads connected to the die pads.

# EXAMPLE BOARD LAYOUT

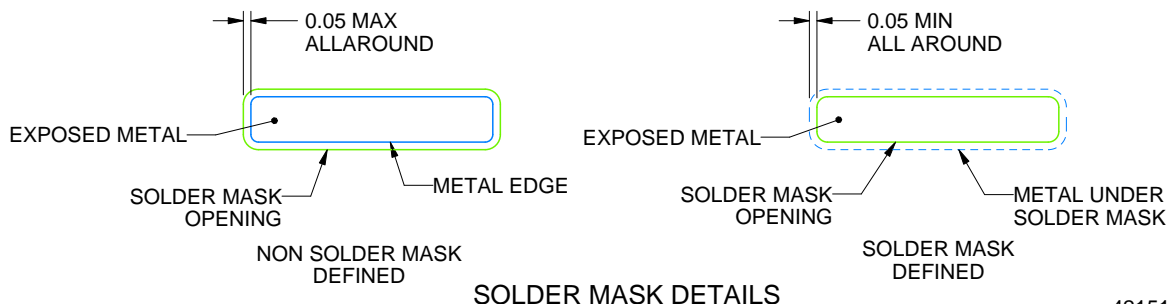
PT0048A

LQFP - 1.6 mm max height

LOW PROFILE QUAD FLATPACK



LAND PATTERN EXAMPLE  
EXPOSED METAL SHOWN  
SCALE 10.000



SOLDER MASK DETAILS

4215159/B 11/2023

NOTES: (continued)

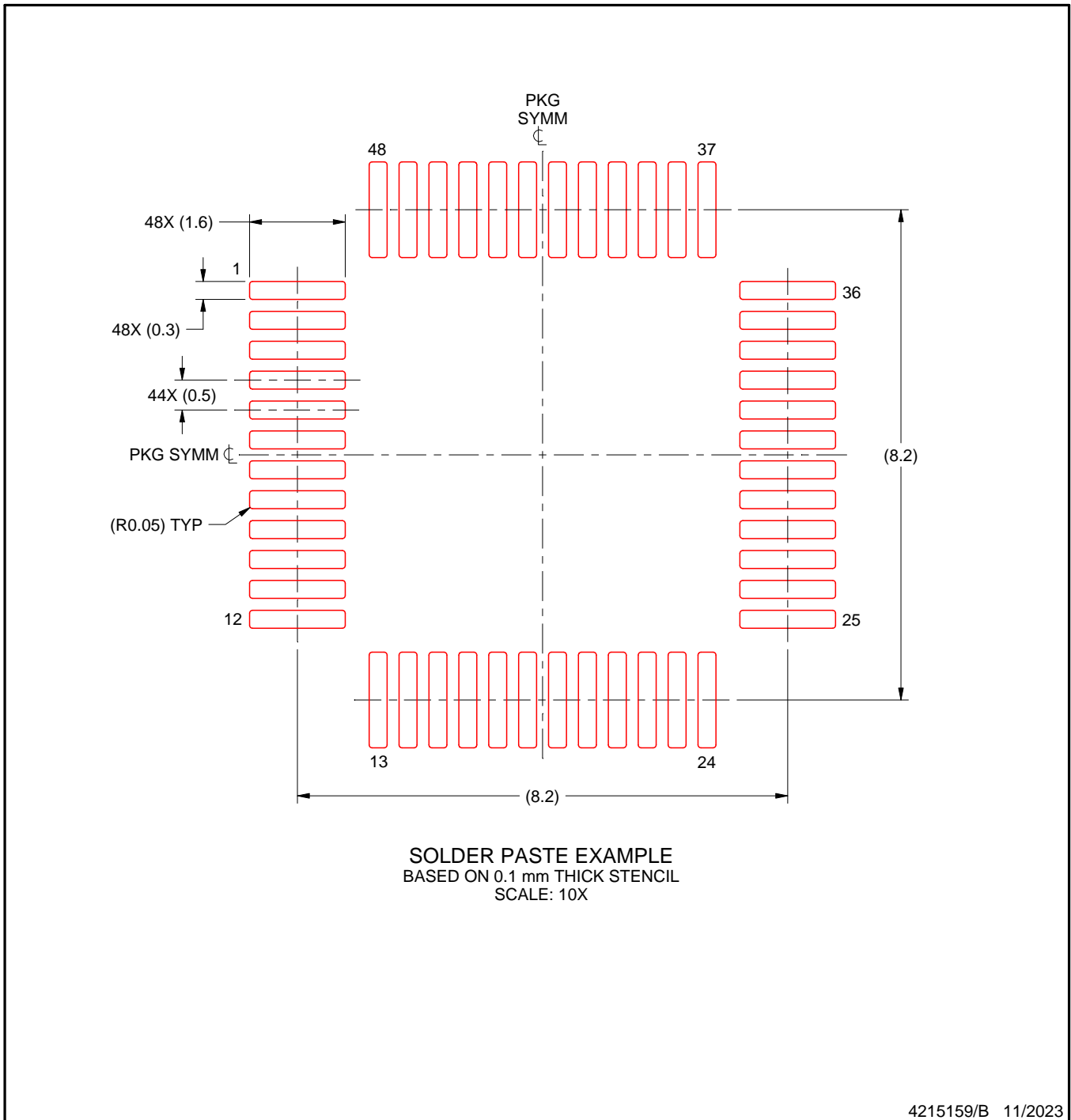
- 5. Publication IPC-7351 may have alternate designs.
- 6. Solder mask tolerances between and around signal pads can vary based on board fabrication site.

# EXAMPLE STENCIL DESIGN

PT0048A

LQFP - 1.6 mm max height

LOW PROFILE QUAD FLATPACK



NOTES: (continued)

7. Laser cutting apertures with trapezoidal walls and rounded corners may offer better paste release. IPC-7525 may have alternate design recommendations.
8. Board assembly site may have different recommendations for stencil design.

## IMPORTANT NOTICE AND DISCLAIMER

TI PROVIDES TECHNICAL AND RELIABILITY DATA (INCLUDING DATASHEETS), DESIGN RESOURCES (INCLUDING REFERENCE DESIGNS), APPLICATION OR OTHER DESIGN ADVICE, WEB TOOLS, SAFETY INFORMATION, AND OTHER RESOURCES "AS IS" AND WITH ALL FAULTS, AND DISCLAIMS ALL WARRANTIES, EXPRESS AND IMPLIED, INCLUDING WITHOUT LIMITATION ANY IMPLIED WARRANTIES OF MERCHANTABILITY, FITNESS FOR A PARTICULAR PURPOSE OR NON-INFRINGEMENT OF THIRD PARTY INTELLECTUAL PROPERTY RIGHTS.

These resources are intended for skilled developers designing with TI products. You are solely responsible for (1) selecting the appropriate TI products for your application, (2) designing, validating and testing your application, and (3) ensuring your application meets applicable standards, and any other safety, security, regulatory or other requirements.

These resources are subject to change without notice. TI grants you permission to use these resources only for development of an application that uses the TI products described in the resource. Other reproduction and display of these resources is prohibited. No license is granted to any other TI intellectual property right or to any third party intellectual property right. TI disclaims responsibility for, and you fully indemnify TI and its representatives against any claims, damages, costs, losses, and liabilities arising out of your use of these resources.

TI's products are provided subject to [TI's Terms of Sale](#), [TI's General Quality Guidelines](#), or other applicable terms available either on [ti.com](#) or provided in conjunction with such TI products. TI's provision of these resources does not expand or otherwise alter TI's applicable warranties or warranty disclaimers for TI products. Unless TI explicitly designates a product as custom or customer-specified, TI products are standard, catalog, general purpose devices.

TI objects to and rejects any additional or different terms you may propose.

Copyright © 2026, Texas Instruments Incorporated

Last updated 10/2025