

# OPA2834 50-MHz, 170- $\mu$ A, Negative-Rail In, Rail-to-Rail Out, Voltage-Feedback Amplifier

## 1 Features

- Ultra-low power:
  - Supply voltage: 2.7 V to 5.4 V
  - Quiescent current ( $I_Q$ ): 170  $\mu$ A/ch (typical)
- Bandwidth: 50 MHz ( $G = 1$  V/V)
- Slew rate: 26 V/ $\mu$ s
- Settling time (0.1%): 88 ns ( $2 \cdot V_{STEP}$ )
- $HD_2$ ,  $HD_3$ : -131 dBc, -146 dBc at 10 kHz ( $2 V_{PP}$ )
- Input voltage noise: 12 nV/ $\sqrt{Hz}$  ( $f = 10$  kHz)
- Input offset voltage: 350  $\mu$ V ( $\pm 1.9$  mV max)
- Negative rail input, rail-to-rail output (RRO)
  - Input voltage range: -0.2 V to 3.9 V (5-V supply)
- Operating temperature range: -40°C to +125°C

## 2 Applications

- Current sensing in power supplies
- Low-power signal conditioning
- Battery-powered applications
- Portable voice recorders
- Low-power SAR and  $\Delta\Sigma$  ADC driver
- Portable devices

## 3 Description

The OPA2834 is a dual-channel, ultra-low-power, rail-to-rail output, negative-rail input, voltage-feedback (VFB) operational amplifier designed to operate over a power-supply range of 2.7 V to 5.4 V with a single supply, or  $\pm 1.35$  V to  $\pm 2.7$  V with a dual supply. Consuming only 170  $\mu$ A per channel and with a unity-gain bandwidth of 50 MHz, this amplifier sets an industry-leading performance-to-power ratio for rail-to-rail amplifiers.

For battery-powered and portable applications where low power consumption is of key importance, the OPA2834 offers an excellent bandwidth to  $I_Q$  ratio. OPA2834 offers very low distortion making it very suitable for data acquisition systems and microphone pre-amplifier.

See the [Device Comparison Table](#) for a selection of low-power, low-noise, 5-V amplifiers from Texas Instruments with a gain-bandwidth product from 20 MHz to 300 MHz.

### Device Information<sup>(1)</sup>

PART NUMBER	PACKAGE	BODY SIZE (NOM)
OPA2834	VSSOP (8)	3.00 mm x 3.00 mm

(1) For all available packages, see the orderable addendum at the end of the data sheet.

**1-kHz FFT Plot**  
( $V_{OUT} = 1$  V<sub>RMS</sub>,  $R_L = 100$  k $\Omega$ ,  $G = 1$ )

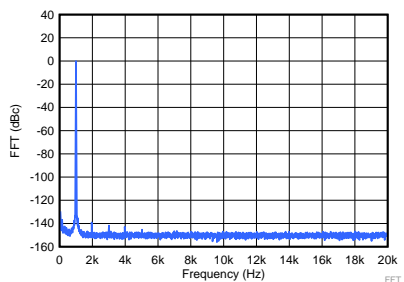

### Low-Side, Current-Shunt Monitoring

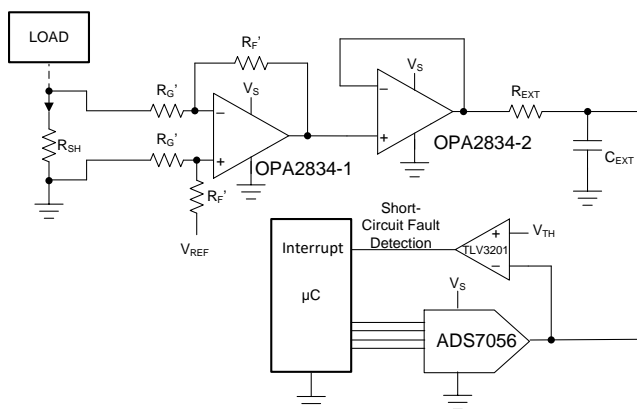

## Table of Contents

<b>1 Features</b> .....	<b>1</b>	8.2 Functional Block Diagrams .....	<b>15</b>
<b>2 Applications</b> .....	<b>1</b>	8.3 Feature Description .....	<b>15</b>
<b>3 Description</b> .....	<b>1</b>	8.4 Device Functional Modes .....	<b>17</b>
<b>4 Revision History</b> .....	<b>2</b>	<b>9 Application and Implementation</b> .....	<b>20</b>
<b>5 Device Comparison Table</b> .....	<b>3</b>	9.1 Application Information .....	<b>21</b>
<b>6 Pin Configuration and Functions</b> .....	<b>3</b>	9.2 Typical Applications .....	<b>21</b>
<b>7 Specifications</b> .....	<b>4</b>	<b>10 Power Supply Recommendations</b> .....	<b>25</b>
7.1 Absolute Maximum Ratings .....	<b>4</b>	<b>11 Layout</b> .....	<b>26</b>
7.2 ESD Ratings .....	<b>4</b>	11.1 Layout Guidelines .....	<b>26</b>
7.3 Recommended Operating Conditions .....	<b>4</b>	11.2 Layout Examples .....	<b>26</b>
7.4 Thermal Information .....	<b>4</b>	<b>12 Device and Documentation Support</b> .....	<b>27</b>
7.5 Electrical Characteristics: 3V to 5V .....	<b>5</b>	12.1 Documentation Support .....	<b>27</b>
7.6 Typical Characteristics: $V_S = 5\text{ V}$ .....	<b>6</b>	12.2 Receiving Notification of Documentation Updates .....	<b>27</b>
7.7 Typical Characteristics: $V_S = 3.0\text{ V}$ .....	<b>9</b>	12.3 Community Resources .....	<b>27</b>
7.8 Typical Characteristics: $\pm 2.5\text{-V}$ to $\pm 1.5\text{-V}$ Split Supply .....	<b>12</b>	12.4 Trademarks .....	<b>27</b>
<b>8 Detailed Description</b> .....	<b>15</b>	12.5 Electrostatic Discharge Caution .....	<b>27</b>
8.1 Overview .....	<b>15</b>	12.6 Glossary .....	<b>27</b>
		<b>13 Mechanical, Packaging, and Orderable Information</b> .....	<b>27</b>

## 4 Revision History

NOTE: Page numbers for previous revisions may differ from page numbers in the current version.

Changes from Original (June 2019) to Revision A	Page
• Changed document status from APL to production data .....	<b>1</b>

## 5 Device Comparison Table

PART NUMBER	CHANNELS	$A_v = +1$ BANDWIDTH (MHz)	5-V $I_Q$ (mA, Typ 25°C)	INPUT NOISE VOLTAGE (nV/√Hz)	2- $V_{PP}$ THD (dBc, 100 kHz)	RAIL-TO-RAIL INPUT/OUTPUT	Single Channel
OPA2834	2	50	0.17	12		$V_{S-}$ , output	—
OPA2835	2	56	0.25	9.4	-104	$V_{S-}$ , output	OPA835
OPA2836	2	205	1.0	4.6	-118	$V_{S-}$ , output	OPA836
OPA2837	2	105	0.6	4.7	-118	$V_{S-}$ , output	OPA837
OPA838	1	—	0.96	1.9	-110	$V_{S-}$ , output	—

## 6 Pin Configuration and Functions

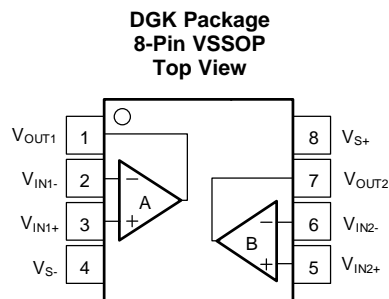

**Pin Functions**

PIN		FUNCTION <sup>(1)</sup>	DESCRIPTION
NO.	NAME		
1	$V_{OUT1}$	O	Amplifier 1 output pin
2	$V_{IN1-}$	I	Amplifier 1 inverting input pin
3	$V_{IN1+}$	I	Amplifier 1 noninverting input pin
4	$V_{S-}$	P	Negative power-supply pin
5	$V_{IN2+}$	I	Amplifier 2 noninverting input pin
6	$V_{IN2-}$	I	Amplifier 2 inverting input pin
7	$V_{OUT2}$	O	Amplifier 2 output pin
8	$V_{S+}$	P	Positive power-supply input

(1) I = input, O = output, and P = power.

## 7 Specifications

### 7.1 Absolute Maximum Ratings

over operating free-air temperature range (unless otherwise noted)<sup>(1)</sup>

		MIN	MAX	UNIT
V <sub>S-</sub> to V <sub>S+</sub>	Supply voltage (total bipolar supplies) <sup>(2)</sup>		5.5	V
	Supply turnon/off maximum dV/dT <sup>(3)</sup>		1	V/μs
V <sub>I</sub>	Input voltage	V <sub>S-</sub> – 0.5	V <sub>S+</sub> + 0.5	V
V <sub>ID</sub>	Differential input voltage		±1	V
I <sub>I</sub>	Continuous input current <sup>(4)</sup>		±10	mA
I <sub>O</sub>	Continuous output current <sup>(5)</sup>		±20	mA
	Continuous power dissipation	<i>See Thermal Information</i>		
T <sub>J</sub>	Maximum junction temperature		150	°C
T <sub>A</sub>	Operating free-air temperature	–40	125	°C
T <sub>stg</sub>	Storage temperature	–65	150	°C

- (1) Stresses beyond those listed under *Absolute Maximum Ratings* may cause permanent damage to the device. These are stress ratings only, which do not imply functional operation of the device at these or any other conditions beyond those indicated under *Recommended Operating Conditions*. Exposure to absolute-maximum-rated conditions for extended periods may affect device reliability.
- (2) V<sub>S</sub> is the total supply voltage given by V<sub>S</sub> = V<sub>S+</sub> – V<sub>S-</sub>.
- (3) Staying below this ± supply turnon edge rate prevents the edge-triggered ESD absorption device across the supply pins from turning on.
- (4) Continuous input current limit for both the ESD diodes to supply pins and amplifier differential input clamp diodes. The differential input clamp diodes limit the voltage across them to 1 V with this continuous input current flowing through them.
- (5) Long-term continuous current for electromigration limits.

### 7.2 ESD Ratings

			VALUE	UNIT
V <sub>(ESD)</sub>	Electrostatic discharge	Human body model (HBM), per ANSI/ESDA/JEDEC JS-001 <sup>(1)</sup>	±2000	V
		Charged-device model (CDM), per JEDEC specification JESD22 <sup>(2)</sup>	±1500	

- (1) JEDEC document JEP155 states that 500-V HBM allows safe manufacturing with a standard ESD control process.
- (2) JEDEC document JEP157 states that 250-V CDM allows safe manufacturing with a standard ESD control process.

### 7.3 Recommended Operating Conditions

over operating free-air temperature range (unless otherwise noted)

		MIN	NOM	MAX	UNIT
V <sub>S+</sub>	Single-supply positive voltage	2.7	5	5.4	V
T <sub>A</sub>	Ambient temperature	–40	25	125	°C

### 7.4 Thermal Information

THERMAL METRIC <sup>(1)</sup>		OPA2834	UNIT
		DGK (VSSOP)	
		8 PINS	
R <sub>θJA</sub>	Junction-to-ambient thermal resistance	192.6	°C/W
R <sub>θJC(top)</sub>	Junction-to-case (top) thermal resistance	79.3	°C/W
R <sub>θJB</sub>	Junction-to-board thermal resistance	114.3	°C/W
Ψ <sub>JT</sub>	Junction-to-top characterization parameter	15.7	°C/W
Y <sub>JB</sub>	Junction-to-board characterization parameter	112.6	°C/W

- (1) For more information about traditional and new thermal metrics, see the *Semiconductor and IC Package Thermal Metrics* application report.

## 7.5 Electrical Characteristics: 3V to 5V

$V_S = 3\text{ V to }5\text{ V}$ ,  $R_F = 0\ \Omega$ ,  $C_L = 4\text{ pF}$ ,  $R_L = 5\text{ k}\Omega$  referenced to mid-supply,  $G = 1\text{ V/V}$ , input and output  $V_{CM} = \text{mid-supply}$ , and  $T_A \approx 25^\circ\text{C}$  (unless otherwise noted)

PARAMETER		TEST CONDITIONS	MIN	TYP	MAX	UNIT
<b>AC PERFORMANCE</b>						
SSBW	Small-signal bandwidth	$V_O = 20\text{ mV}_{PP}$ , $G = 1$ , $< 1\text{ dB peaking}$		50		MHz
		$V_O = 20\text{ mV}_{PP}$ , $G = 2$ , $R_F = 3.65\text{ k}\Omega$		20		
GBWP	Gain-bandwidth product			20		MHz
LSBW	Large-signal bandwidth	$V_O = 2\text{ V}_{PP}$ , $V_S = 5\text{ V}$		6		MHz
		$V_O = 1\text{ V}_{PP}$ , $V_S = 3\text{ V}$		9		
	Bandwidth for 0.1-dB flatness	$V_O = 200\text{ mV}_{PP}$ , $G = 2$ , $R_F = 3.65\text{ k}\Omega$		9		MHz
SR	Slew rate	$V_S = 5\text{ V}$ , $V_O = 2\text{-V step}$ , 20% to 80%		26		V/ $\mu\text{s}$
		$V_S = 3\text{ V}$ , $V_O = 1\text{-V step}$ , 20% to 80%		17		
$t_R$ , $t_F$	Rise, fall time	$V_O = 200\text{-mV step}$ , input $t_R = 1\text{ ns}$		16		ns
	Settling time to 0.1%	$V_O = 2\text{-V step}$ , input $t_R = 50\text{ ns}$		88		ns
	Settling time to 0.01%	$V_O = 2\text{-V step}$ , input $t_R = 50\text{ ns}$		110		
	Over/Under Shoot	$V_O = 2\text{-V step}$ , input $t_R = 50\text{ ns}$		0.6		%
	Overdrive recovery time	$G = 2$ , 2x output overdrive		240		ns
HD2	Second-order harmonic distortion	$f = 10\text{ kHz}$ , $V_O = 2\text{ V}_{PP}$		-131		dBc
HD3	Third-order harmonic distortion	$f = 10\text{ kHz}$ , $V_O = 2\text{ V}_{PP}$		-143		
$e_N$	Input voltage noise	$f > 10\text{ kHz}$ , 1/f corner at 150 Hz		12		nV/ $\sqrt{\text{Hz}}$
$i_N$	Input current noise	$f > 10\text{ kHz}$ , 1/f corner at 900 Hz		0.2		pA/ $\sqrt{\text{Hz}}$
	Channel-to-channel crosstalk	$f = 100\text{ kHz}$ , $V_O = 2\text{ V}_{PP}$		-130		dBc
<b>DC PERFORMANCE</b>						
$A_{OL}$	Open-loop voltage gain	$V_O = \pm 1\text{ V}$	102	124		dB
$V_{OS}$	Input-referred offset voltage			0.35	1.9	mV
		$T_A = -40^\circ\text{C to }+125^\circ\text{C}^{(1)}$		0.5	2.1	
	Input offset voltage drift	$T_A = -40^\circ\text{C to }+125^\circ\text{C}^{(1)}$		1.2	5	$\mu\text{V}/^\circ\text{C}$
	Input bias current			50	90	nA
		$T_A = -40^\circ\text{C to }+125^\circ\text{C}^{(1)}$		70	115	
	Input offset current			5	30	nA
<b>INPUT</b>						
$V_{ICR}$	Common-mode input range		$V_{S-} - 0.2$		$V_{S+} - 1.1$	V
		$T_A = -40^\circ\text{C to }+125^\circ\text{C}^{(1)}$	$V_{S-} - 0.1$		$V_{S+} - 1.1$	
CMRR	Common-mode rejection ratio	$V_{CM} = V_{S-} - 0.2\text{ V to }V_{S+} - 1.1\text{ V}$	86	104		dB
	Common-mode input impedance			1050    1.1		M $\Omega$    pF
	Differential input impedance			1    0.2		
<b>OUTPUT</b>						
$V_{OL}$	Output voltage, low			$V_{S+} + 0.02$	$V_{S-} + 0.05$	V
$V_{OH}$	Output voltage, high		$V_{S+} - 0.1$	$V_{S-} - 0.05$		
	Linear output drive (sourcing/sinking)	$V_O = \pm 1\text{ V}$ , $\Delta V_{OS} < 1\text{ mV}$ , $V_S = 5\text{ V}$	16	28		mA
		$V_O = \pm 1\text{ V}$ , $\Delta V_{OS} < 1\text{ mV}$ , $V_S = 3\text{ V}$	11	13.5		
$Z_O$	Closed-loop output impedance	$G = 1$ , $I_{OUT} = \pm 5\text{ mA DC}$		1.1		m $\Omega$
<b>POWER SUPPLY</b>						
$V_S$	Specified operating voltage		2.7		5.4	V
$I_Q$	Quiescent current per amplifier			170	210	$\mu\text{A}$
		$T_A = -40^\circ\text{C to }+125^\circ\text{C}^{(1)}$		220	290	
PSRR	Power-supply rejection ratio	$\Delta V_S = 0.3\text{ V}$	86	103		dB

(1) Based on electrical characterization of 32 devices. Minimum and maximum values are not specified by final automated test equipment (ATE) nor by QA sample testing. Typical specifications are  $\pm 1$  sigma.

## 7.6 Typical Characteristics: $V_s = 5\text{ V}$

$V_{S+} = 5\text{ V}$ ,  $V_{S-} = 0\text{ V}$ ,  $R_F = 0\ \Omega$ ,  $R_L = 5\text{ k}\Omega$ ,  $C_L = 4\text{ pF}$ , input and output referenced to mid-supply, and  $T_A \approx 25^\circ\text{C}$  (unless otherwise noted)

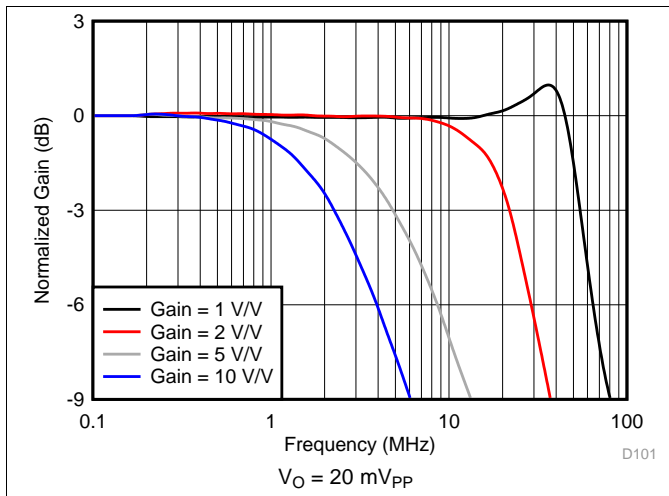

Figure 1. Noninverting Small-Signal Frequency Response

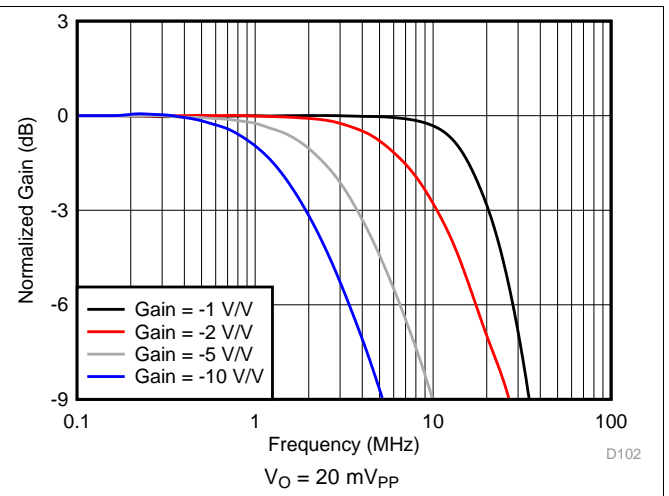

Figure 2. Inverting Small-Signal Frequency Response

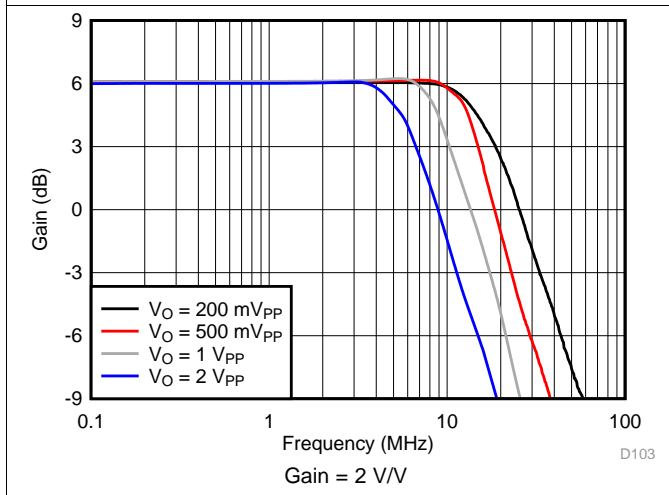

Figure 3. Noninverting Large-Signal Frequency Response

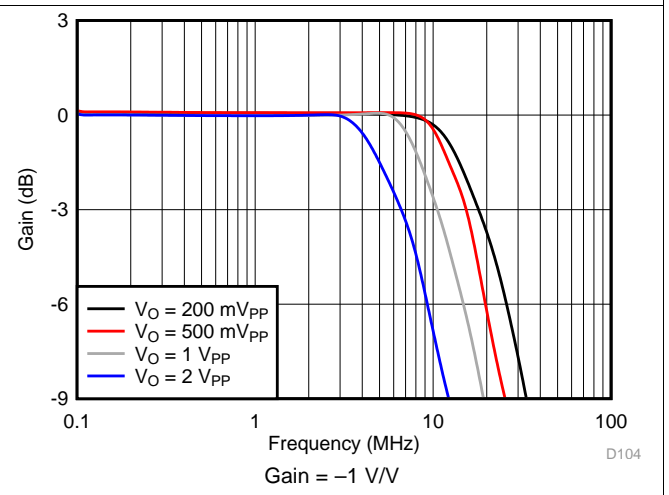

Figure 4. Inverting Large-Signal Frequency Response

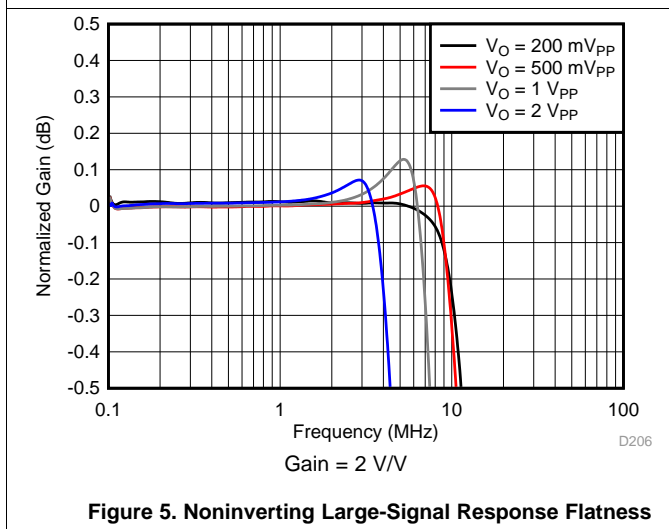

Figure 5. Noninverting Large-Signal Response Flatness

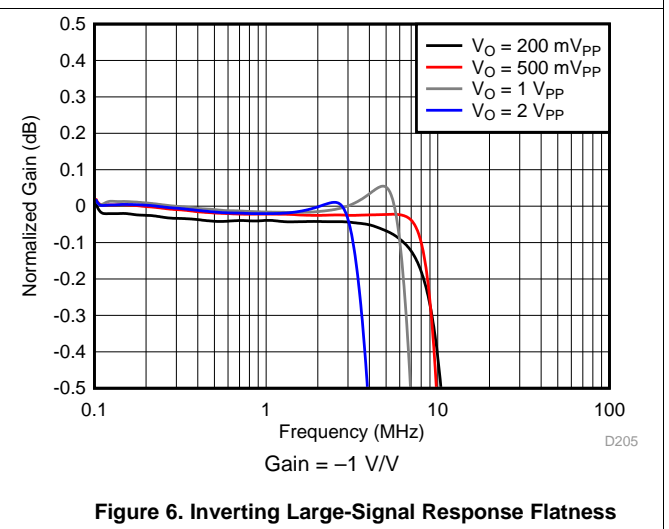

Figure 6. Inverting Large-Signal Response Flatness

Typical Characteristics:  $V_s = 5\text{ V}$  (continued)

$V_{S+} = 5\text{ V}$ ,  $V_{S-} = 0\text{ V}$ ,  $R_F = 0\ \Omega$ ,  $R_L = 5\text{ k}\Omega$ ,  $C_L = 4\text{ pF}$ , input and output referenced to mid-supply, and  $T_A \approx 25^\circ\text{C}$  (unless otherwise noted)

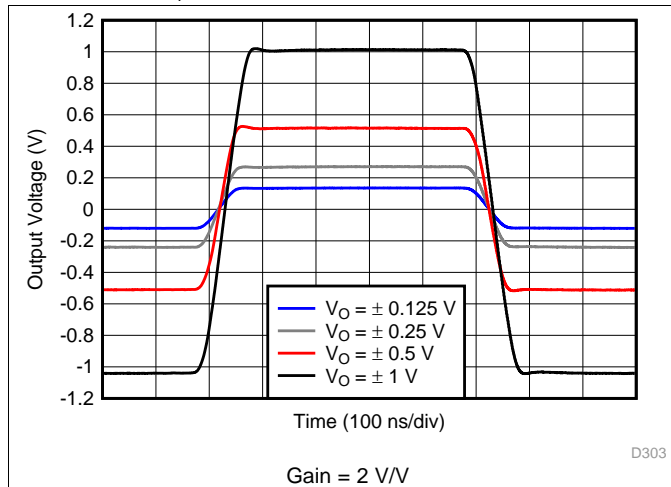

Figure 7. Noninverting Step Response

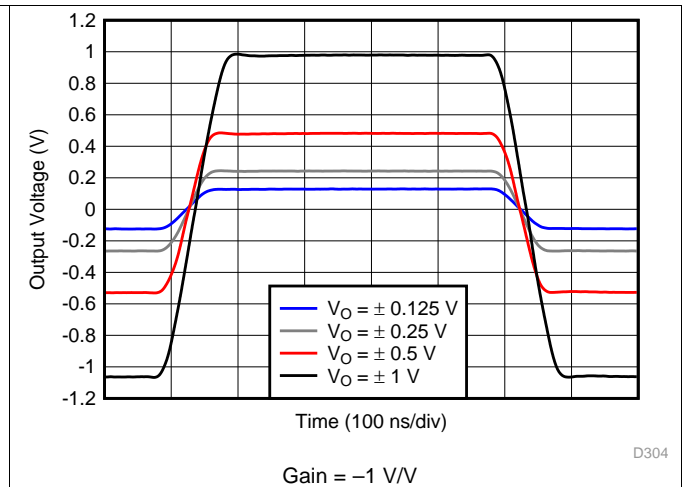

Figure 8. Inverting Step Response

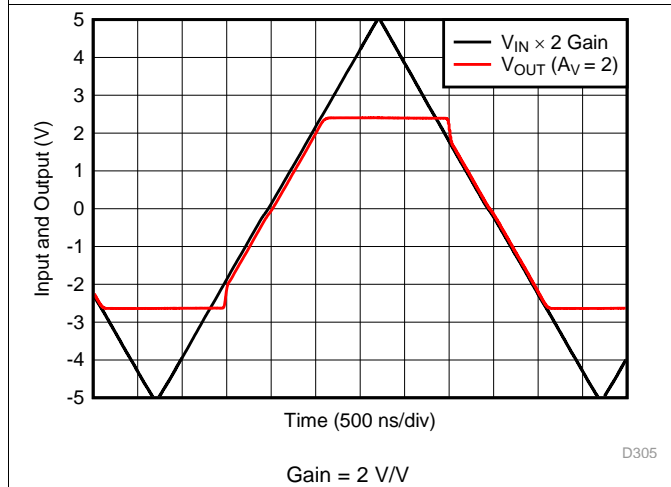

Figure 9. Noninverting Overdrive Recovery

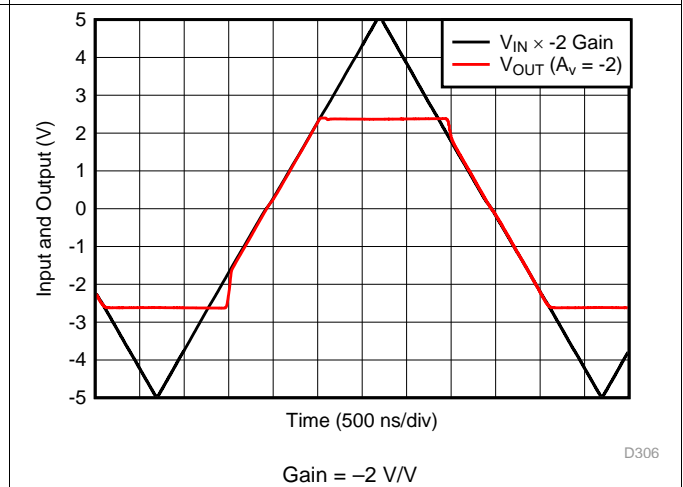

Figure 10. Inverting Overdrive Recovery

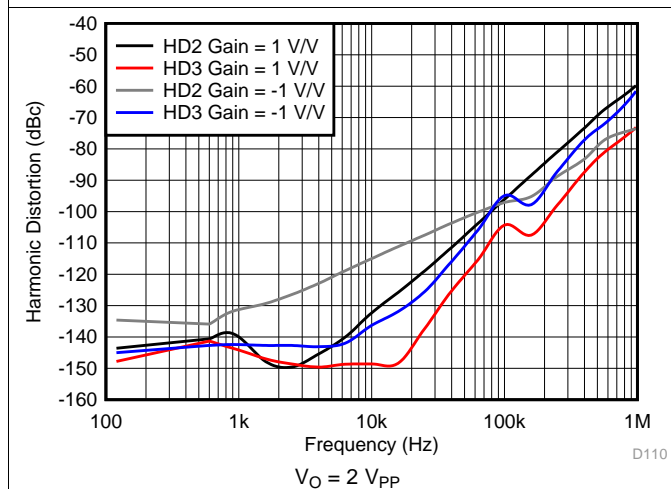

Figure 11. Harmonic Distortion vs Frequency

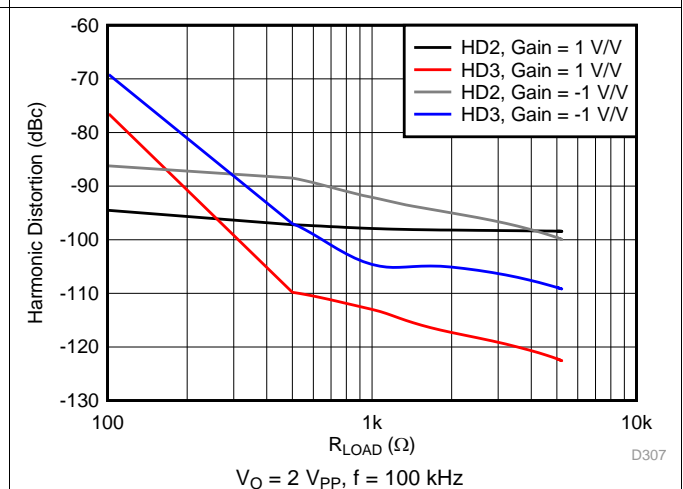
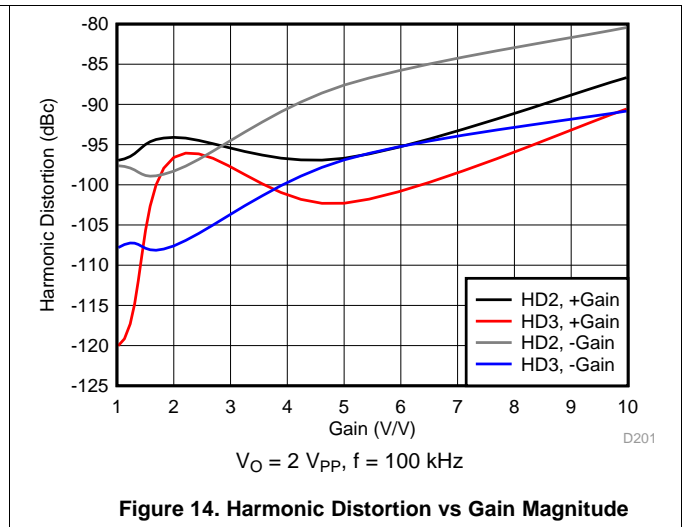
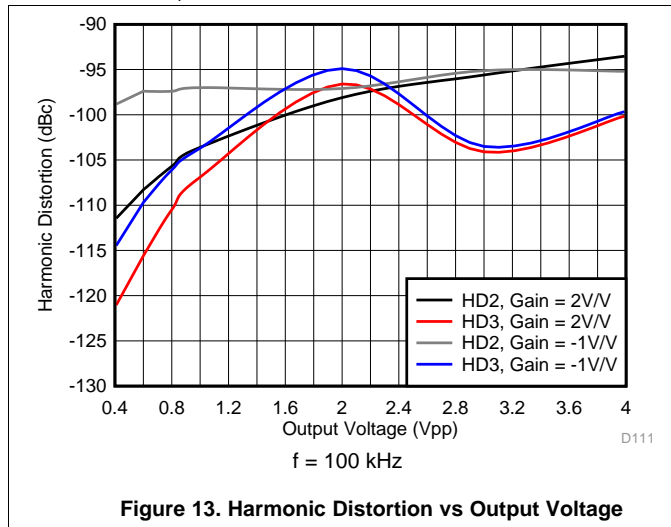

Figure 12. Harmonic Distortion vs  $R_{LOAD}$

**Typical Characteristics:  $V_s = 5\text{ V}$  (continued)**

$V_{S+} = 5\text{ V}$ ,  $V_{S-} = 0\text{ V}$ ,  $R_F = 0\ \Omega$ ,  $R_L = 5\text{ k}\Omega$ ,  $C_L = 4\text{ pF}$ , input and output referenced to mid-supply, and  $T_A \approx 25^\circ\text{C}$  (unless otherwise noted)





### 7.7 Typical Characteristics: $V_S = 3.0\text{ V}$

$V_{S+} = 3\text{ V}$ ,  $V_{S-} = 0\text{ V}$ ,  $R_F = 0\ \Omega$ ,  $R_L = 5\text{ k}\Omega$ ,  $C_L = 4\text{ pF}$ , input and output referenced to mid-supply, and  $T_A \approx 25^\circ\text{C}$  (unless otherwise noted)

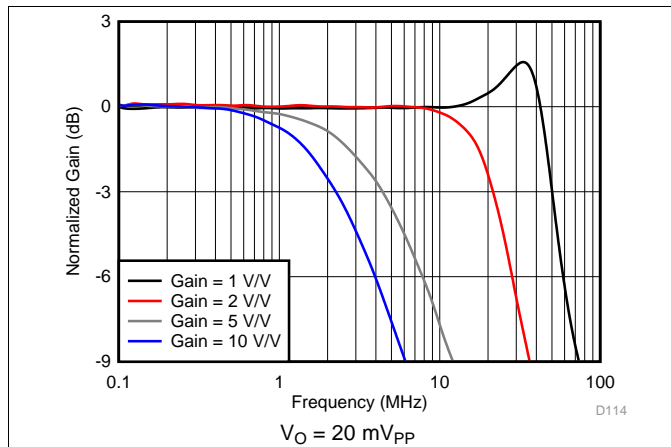

Figure 15. Noninverting Small-Signal Frequency Response

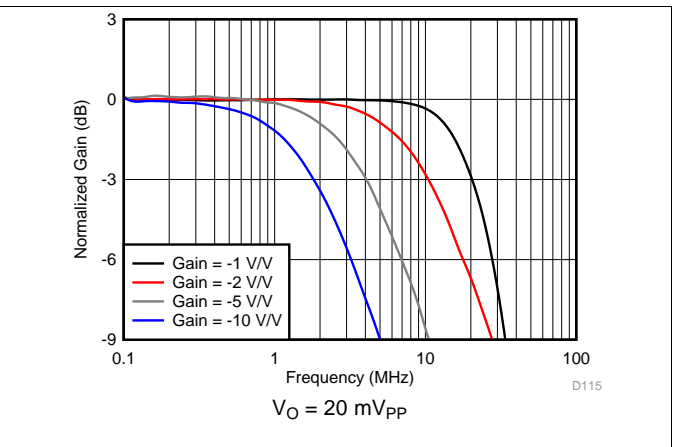

Figure 16. Inverting Small-Signal Frequency Response

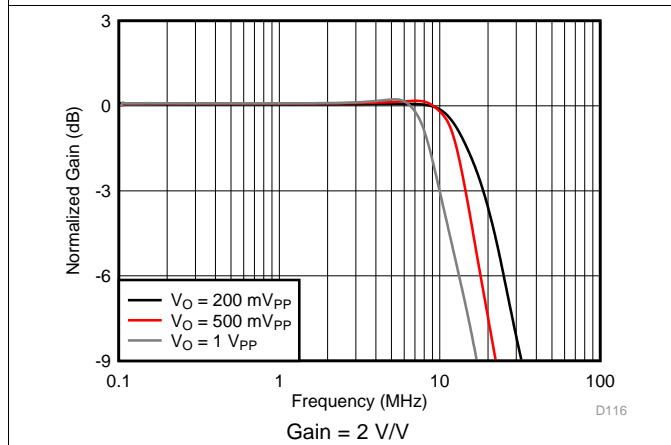

Figure 17. Noninverting Large-Signal Bandwidth

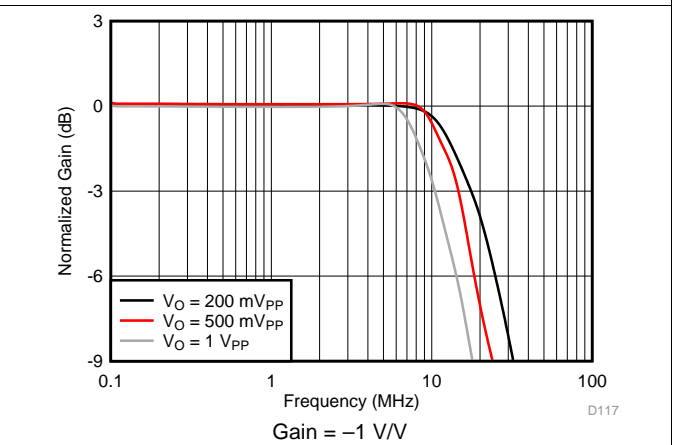

Figure 18. Inverting Large-Signal Bandwidth

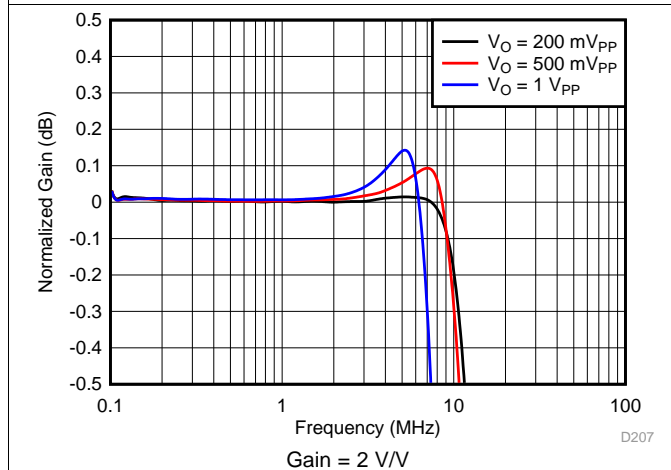

Figure 19. Noninverting Large-Signal Frequency Response Flatness

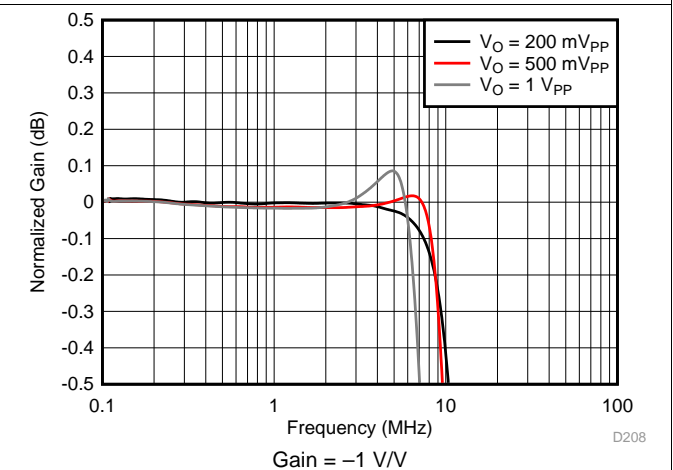
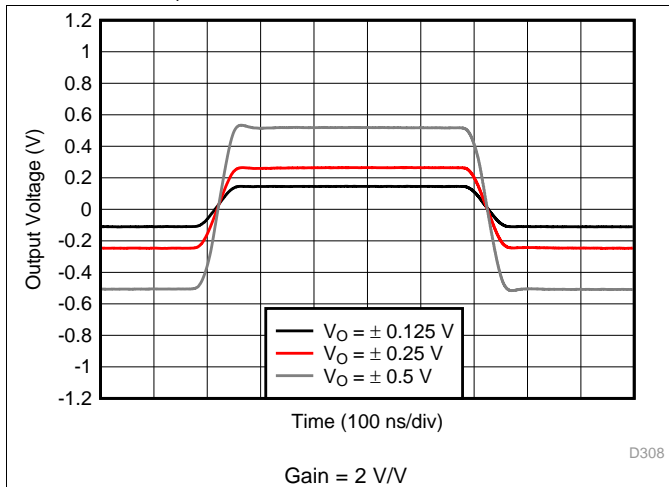

Figure 20. Inverting Large-Signal Frequency Response Flatness

**Typical Characteristics:  $V_S = 3.0\text{ V}$  (continued)**

$V_{S+} = 3\text{ V}$ ,  $V_{S-} = 0\text{ V}$ ,  $R_F = 0\ \Omega$ ,  $R_L = 5\text{ k}\Omega$ ,  $C_L = 4\text{ pF}$ , input and output referenced to mid-supply, and  $T_A \approx 25^\circ\text{C}$  (unless otherwise noted)



**Figure 21. Noninverting Step Response**

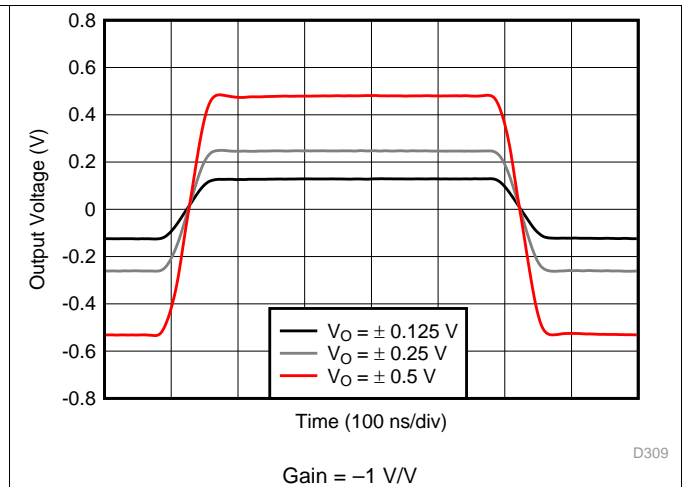

**Figure 22. Inverting Step Response**

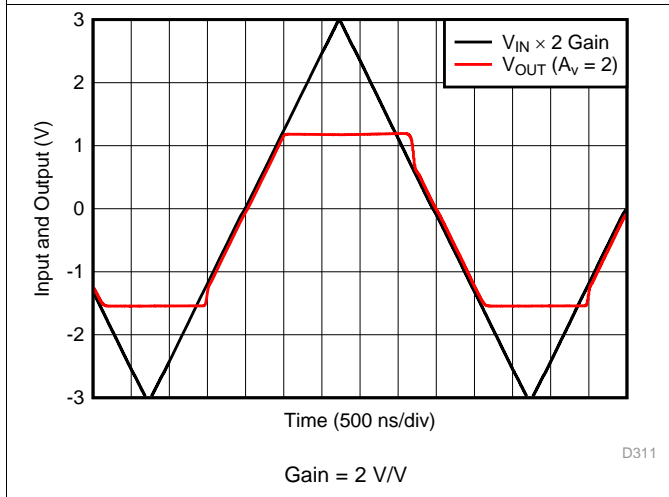

**Figure 23. Noninverting Overdrive Recovery**

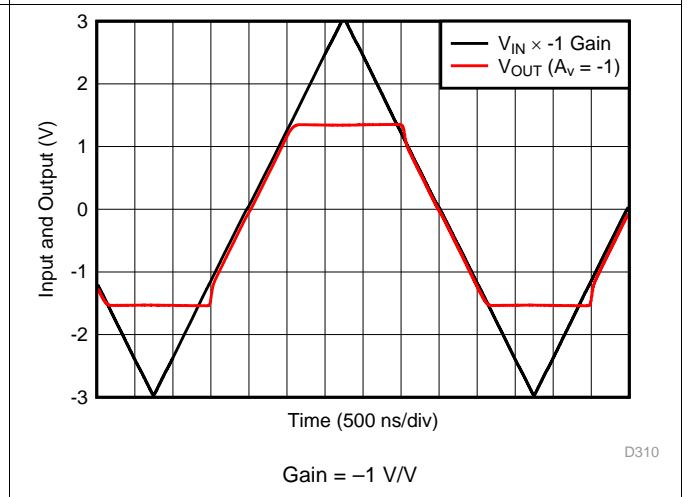

**Figure 24. Inverting Overdrive Recovery**

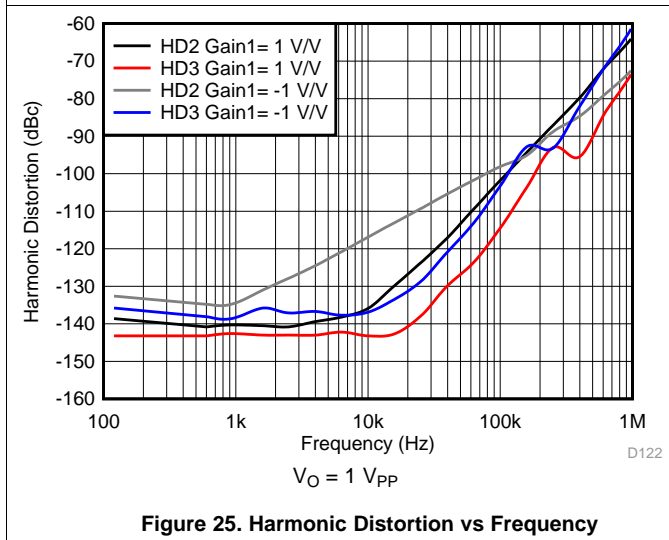

**Figure 25. Harmonic Distortion vs Frequency**

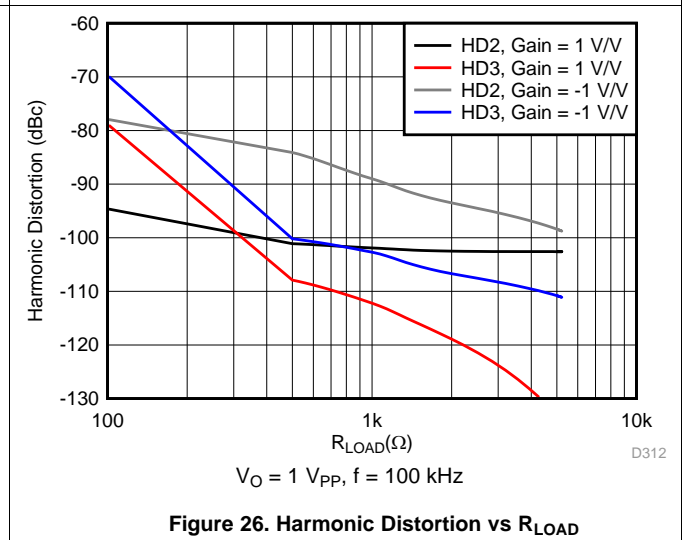

**Figure 26. Harmonic Distortion vs  $R_{LOAD}$**

**Typical Characteristics:  $V_S = 3.0\text{ V}$  (continued)**

$V_{S+} = 3\text{ V}$ ,  $V_{S-} = 0\text{ V}$ ,  $R_F = 0\ \Omega$ ,  $R_L = 5\text{ k}\Omega$ ,  $C_L = 4\text{ pF}$ , input and output referenced to mid-supply, and  $T_A \approx 25^\circ\text{C}$  (unless otherwise noted)

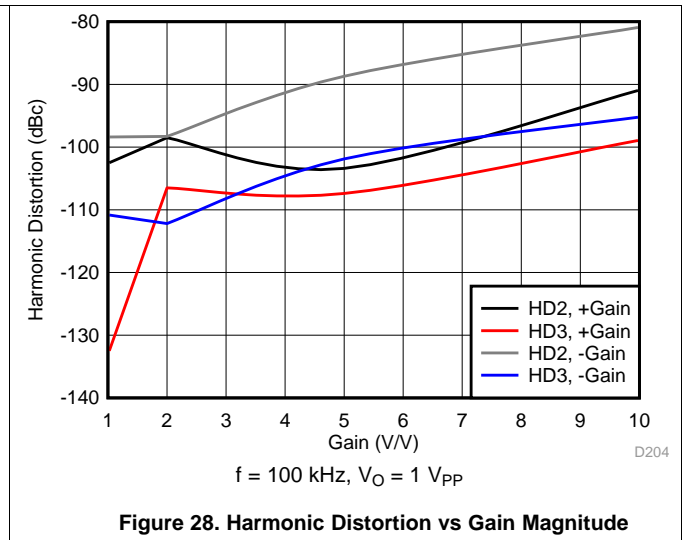
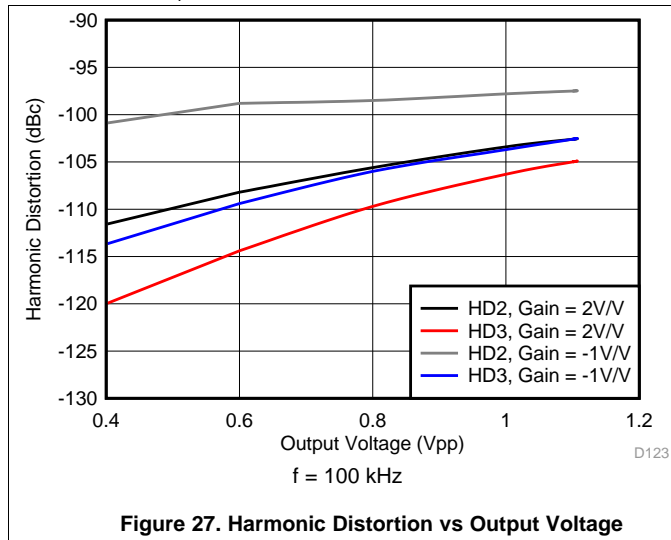

### 7.8 Typical Characteristics: ±2.5-V to ±1.5-V Split Supply

with  $P_D = V_{CC}$  and  $T_A \approx 25^\circ\text{C}$ , gain mentioned in V/V (unless otherwise noted)

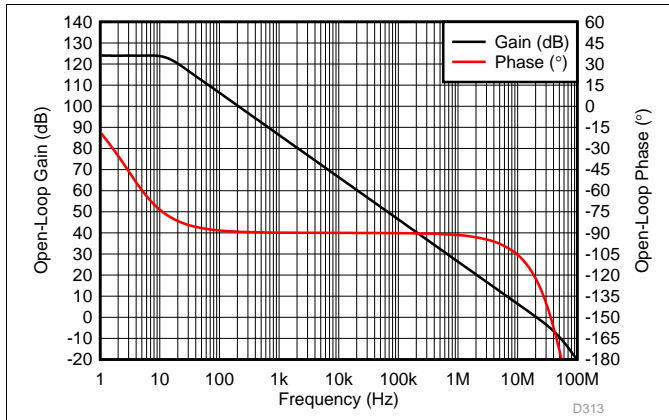

Figure 29. Open-Loop Gain and Phase vs Frequency

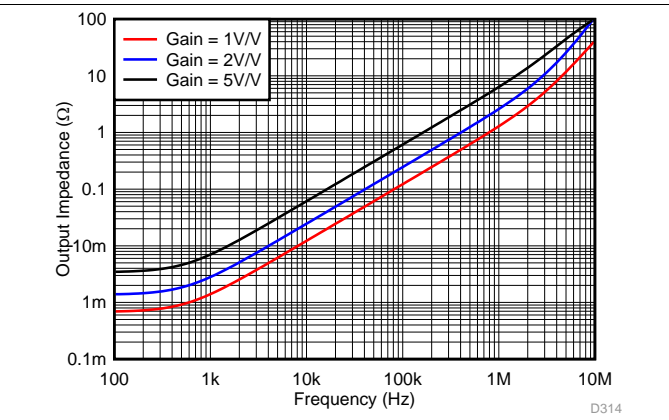

Figure 30. Closed-Loop Output Impedance vs Frequency

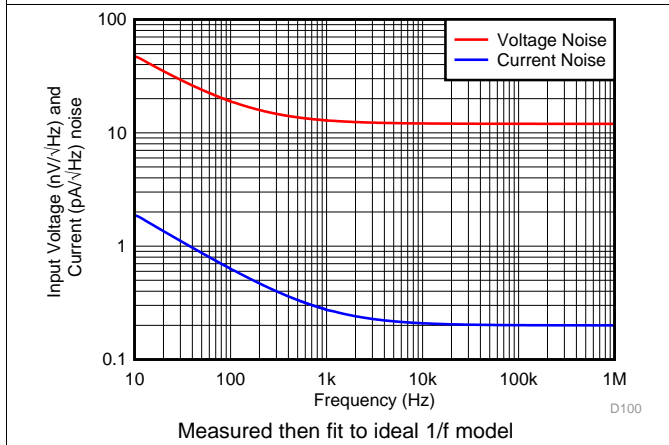

Figure 31. Input Noise Density vs Frequency

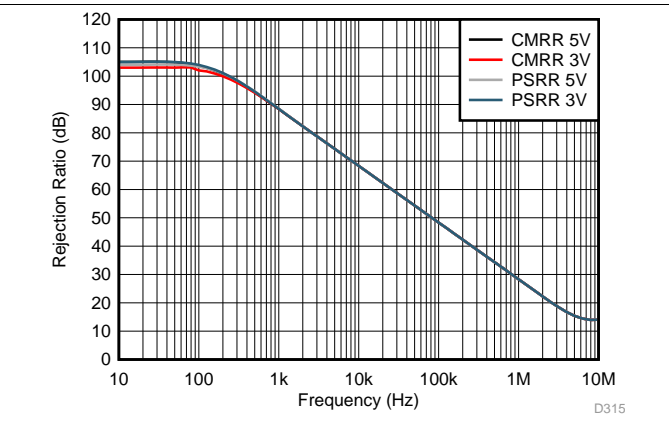

Figure 32. CMRR and PSRR vs Frequency

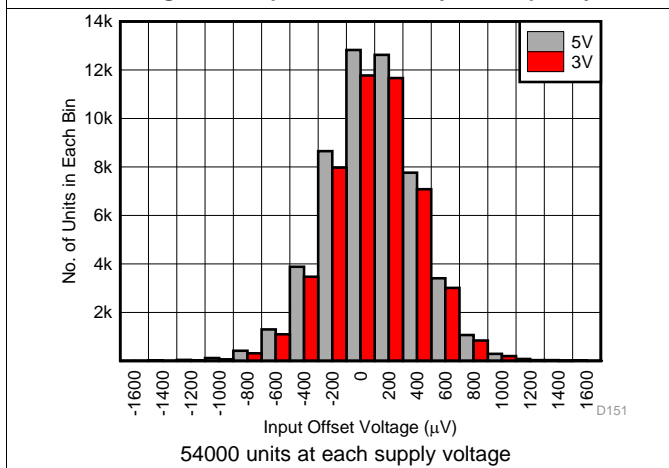

Figure 33. Input Offset Voltage Distribution

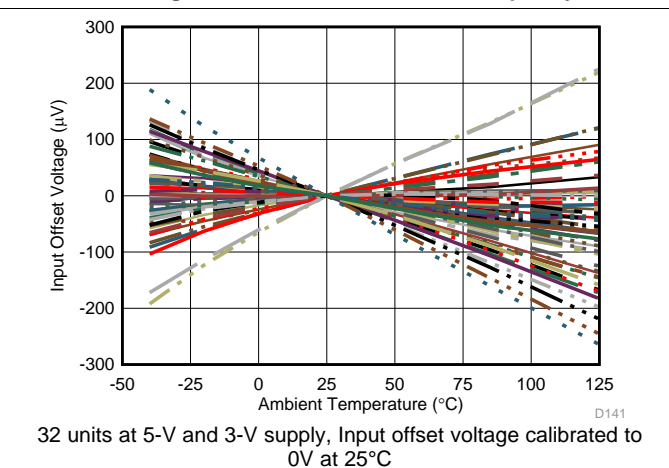

Figure 34. Input Offset Voltage vs Ambient Temperature

Typical Characteristics:  $\pm 2.5\text{-V}$  to  $\pm 1.5\text{-V}$  Split Supply (continued)

with  $P_D = V_{CC}$  and  $T_A \approx 25^\circ\text{C}$ , gain mentioned in V/V (unless otherwise noted)

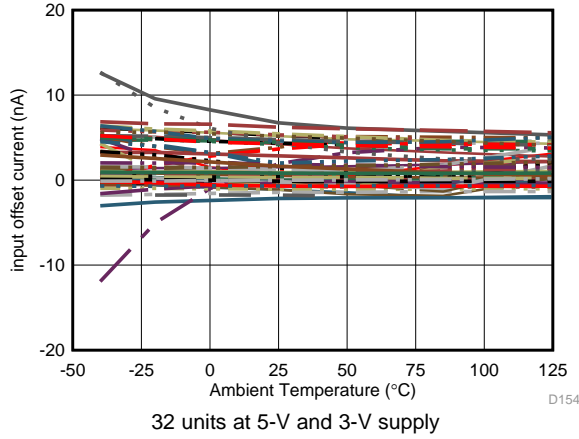

Figure 35. Input Offset Current vs Ambient Temperature

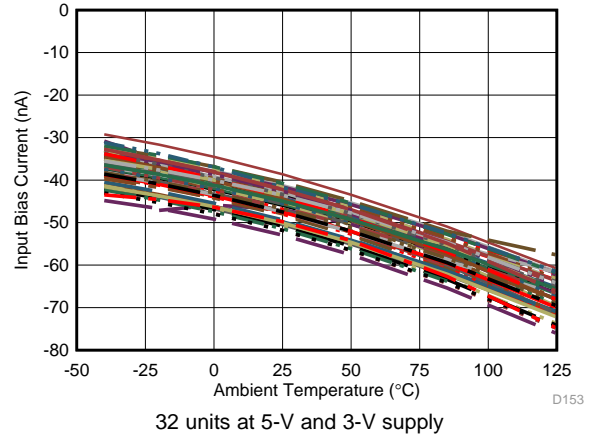

Figure 36. Input Bias Current vs Ambient Temperature

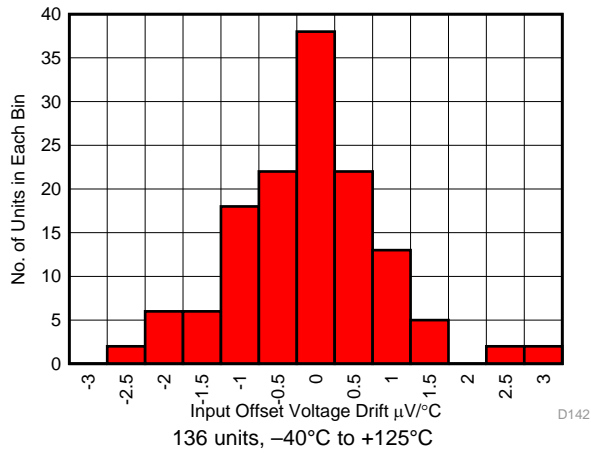

Figure 37. Input Offset Voltage Drift Distribution

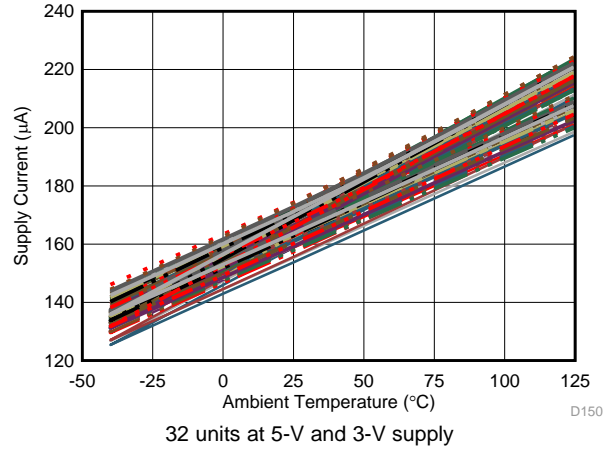

Figure 38. Supply Current vs Ambient Temperature

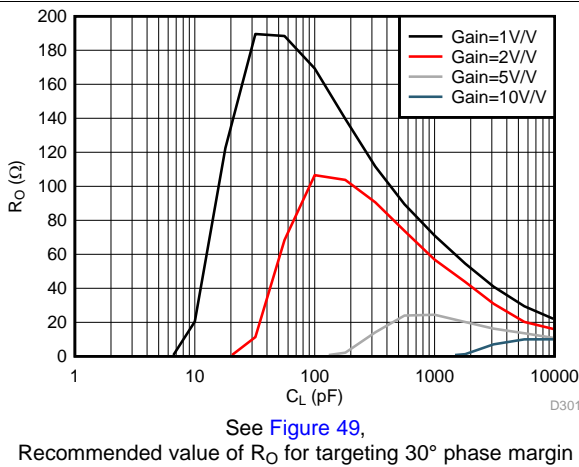

Figure 39. Output Resistor ( $R_O$ ) vs  $C_L$

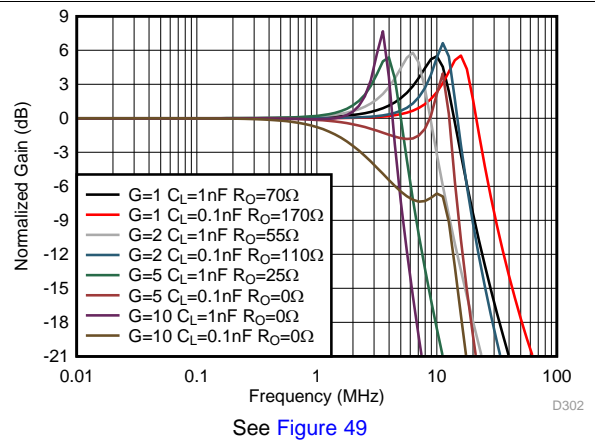
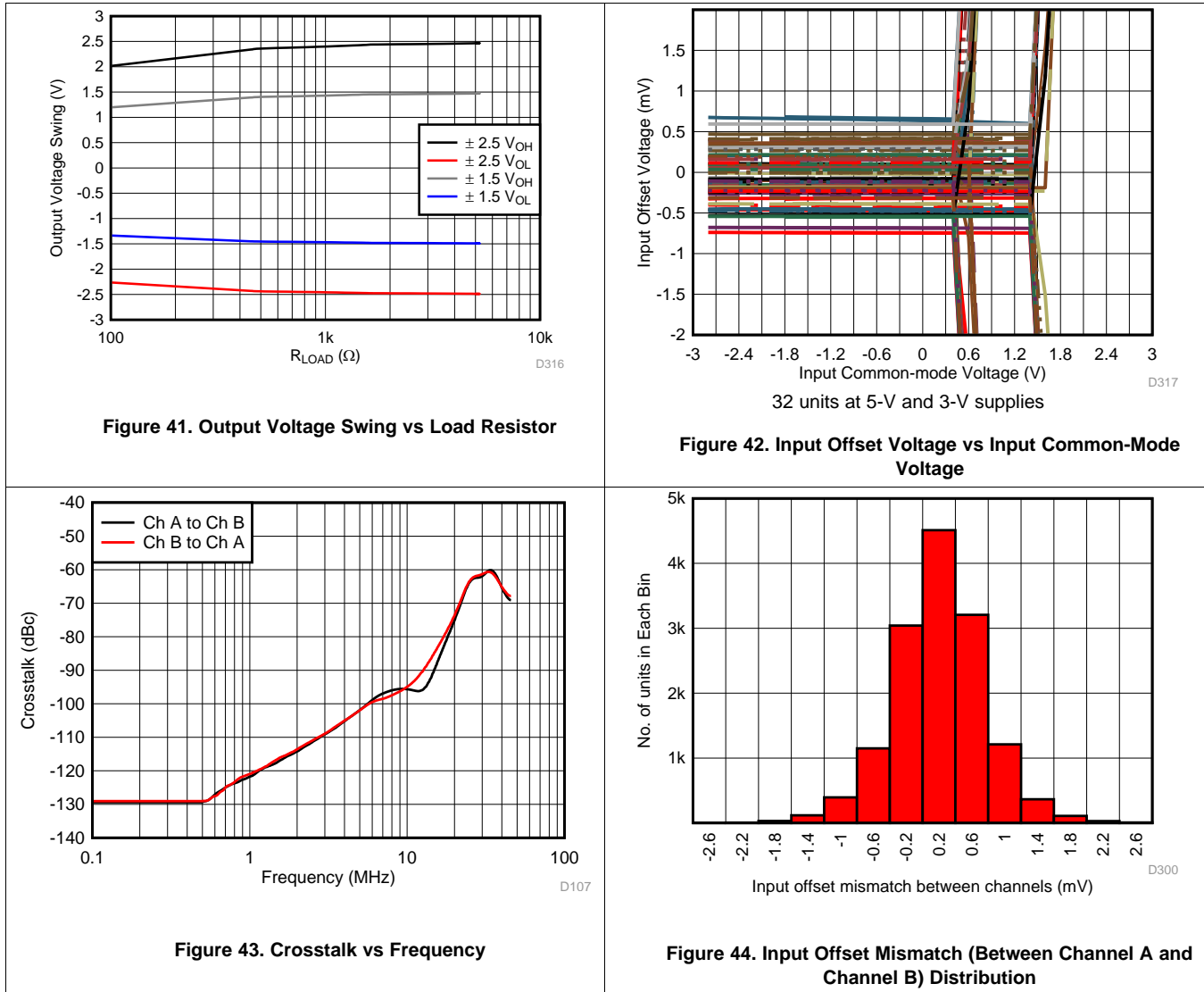

Figure 40. Small-Signal Frequency Response vs  $C_L$  With Recommended  $R_O$

Typical Characteristics:  $\pm 2.5\text{-V}$  to  $\pm 1.5\text{-V}$  Split Supply (continued)

with  $P_D = V_{CC}$  and  $T_A \approx 25^\circ\text{C}$ , gain mentioned in V/V (unless otherwise noted)



## 8 Detailed Description

### 8.1 Overview

The OPA2834 bipolar input operational amplifier offers an unity-gain bandwidth of 50 MHz with ultra-low HD2 and HD3 as shown in the [Electrical Characteristics: 3V to 5V](#). The device can swing to within 100 mV of the supply rails while driving a 5-k $\Omega$  load. The input common-mode voltage of the amplifier can swing to 200 mV below the negative supply rail. This level of performance is achieved at 170  $\mu$ A of quiescent current per amplifier channel.

### 8.2 Functional Block Diagrams

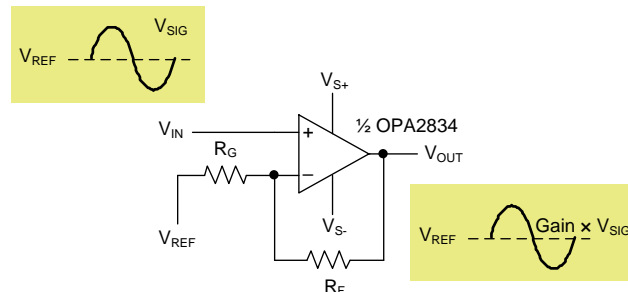

**Figure 45. Noninverting Amplifier**

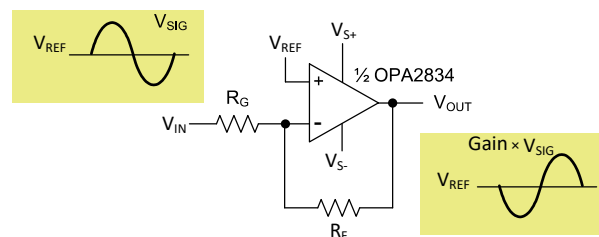

**Figure 46. Inverting Amplifier**

### 8.3 Feature Description

#### 8.3.1 Input Common-Mode Voltage Range

When the primary design goal is a linear amplifier circuit with high CMRR, it is important to not violate the input common-mode voltage range ( $V_{ICR}$ ) of the op amp. The typical specifications for this device are 0.2 V below the negative rail and 1.1 V below the positive rail.

Assuming the op amp is in linear operation, the voltage difference between the input pins is small (ideally 0 V); and the input common-mode voltage is analyzed at either input pin with the other input pin assumed to be at the same potential. The voltage at  $V_{IN+}$  is simple to evaluate. In a noninverting configuration, as shown in [Figure 45](#), the input signal,  $V_{IN}$ , must not violate the  $V_{ICR}$  for this operation. In an inverting configuration, as shown in [Figure 46](#), the reference voltage,  $V_{REF}$ , must be within the  $V_{ICR}$ . Assuming  $V_{REF}$  is within  $V_{ICR}$ , the amplifier is always in the linear operation range irrespective of the amplitude of the input signal  $V_{IN}$ .

The input voltage limits have fixed headroom to the power rails and track the power-supply voltages. For a 5-V supply, the linear input voltage ranges from  $-0.2$  V to 3.9 V and  $-0.2$  V to 1.6 V for a 2.7-V supply. The delta headroom from each power-supply rail is the same in either case:  $-0.2$  V and 1.1 V.

## Feature Description (continued)

### 8.3.2 Output Voltage Range

The OPA2834 is a rail-to-rail output (RRO) op amp. Rail-to-rail output typically means that the output voltage swings within a couple hundred millivolts of the supply rails. There are different ways to specify this parameter, one is with the output still in linear operation and another is with the output saturated. Saturated output voltages are closer to the power-supply rails than linear outputs, but the signal is not a linear representation of the input. Linear output is a better representation of how well a device performs when used as a linear amplifier. Saturation and linear operation limits are affected by the output current, where higher currents lead to lower headroom from either of the output rails.

The *Electrical Characteristics: 3V to 5V* list the saturated output voltage specifications with a 5-kΩ load. Given a light load, the output voltage limits have nearly constant headroom to the power rails and track the power-supply voltages. For example, with a 5-kΩ load and a single 5-V supply, the saturation output voltage ranges from 0.1 V to 4.95 V and ranges from 0.1 V to 2.65 V for a 2.7-V supply. Figure 41 illustrates the saturated voltage-swing limits versus output load resistance.

With a device such as the OPA2834, where the input range is lower than the output range, typically the input limits the available signal swing only in a noninverting gain of 1. Signal swing in noninverting configurations in gains greater than +1 and inverting configurations in any gain is typically limited by the output voltage limits of the op amp.

### 8.3.3 Low-Power Applications and the Effects of Resistor Values on Bandwidth

Choosing the right value of feedback resistor ( $R_F$ ) gives the lowest operating current, maximum bandwidth, lowest DC error, and the best pulse response. In this section for simplicity, the main focus of the signal chain design is assumed to be the total operating current. The feedback resistor used to set the gain value invariably loads the amplifier. For example, in a gain of 2 with  $R_F = R_G = 3.6\text{ k}\Omega$  (see Figure 48) and  $V_{OUT} = 4\text{ V}$  (assumed), 555  $\mu\text{A}$  of current flows through the feedback path to ground. However, using a 3.6-kΩ resistor may not be practical in low-power applications.

In low-power applications, there is a tendency to reduce the current consumed by the amplifier by increasing the gain-setting resistor values in the feedback path. Using larger value gain resistors has two primary side effects (other than lower power), because of the interaction of the resistors with parasitic circuit capacitance. These large-value resistors:

- Lower the bandwidth as a result of the interaction with the parasitic capacitor
- Lower the phase margin by causing
  - Peaking in the frequency response
  - Overshoot and ringing in the pulse response

Figure 47 shows the small-signal frequency response for a noninverting gain of 2 with  $R_F$  and  $R_G$  equal to 2 kΩ, 5 kΩ, 10 kΩ, and 100 kΩ. The test was done with  $R_L = 5\text{ k}\Omega$ . Peaking reduces with lower values of  $R_L$ .

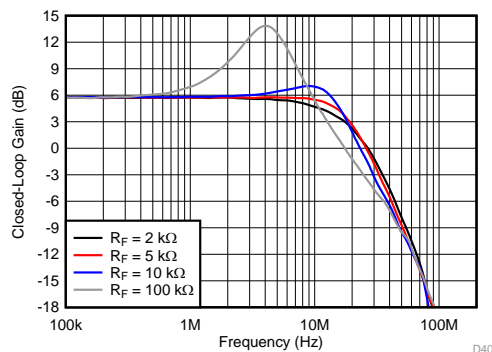

Figure 47. Frequency Response With Various Gain-Setting Resistor Values

As expected, larger value gain resistors result in gain peaking in the frequency response plots (peaking in the frequency response is synonymous with the reduced phase margin).



## Feature Description (continued)

However, there is a simple way to get the best of both worlds. An ideal application requires a high value of  $R_F$  for a particular gain to reduce the operating current but be limited by the reduced phase margin from the interaction of  $R_F$  and  $C_{IN}$ . The trick is simple: adding a capacitor in parallel with  $R_F$  helps compensate the phase margin and restores the flat frequency response (avoids gain peaking). The value of  $C$  chosen must be such that  $R_F \times C_F = C_{IN} \times R_G$ .  $C_{IN}$  for the OPA2834 is 1.1 pF. This value of  $C_{IN}$  is listed in the [Electrical Characteristics: 3V to 5V](#) table as common-mode input impedance. For the case discussed here with a Gain = 2,  $R_F = R_G = 3.6 \text{ k}\Omega$ ,  $C_{IN} = 1.1 \text{ pF}$ , using a  $C_F$  equal to 1 pF is sufficient to reduce the gain peaking. Using a  $C_F$  equal to 1 pF enables users to increase the values of  $R_F$  and  $R_G$  to much higher values beyond 3.6 k $\Omega$  to reduce the operational current consumed by the amplifier.

Figure 48 shows the test circuit.

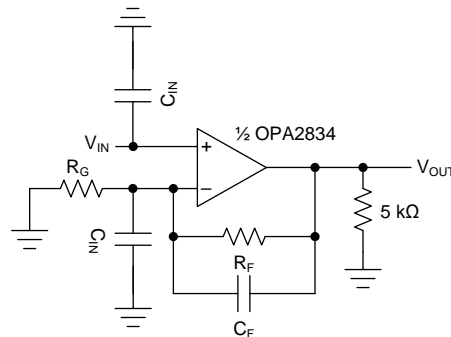

Figure 48. G = 2 Test Circuit for Various Gain-Setting Resistor Values

### 8.3.4 Driving Capacitive Loads

The OPA2834 drives up to a nominal capacitive load of 10 pF on the output with no special consideration and without the need of  $R_O$ . When driving capacitive loads greater than 10 pF, TI recommends using a small resistor ( $R_O$ ) in series with the output as close to the device as possible. Without  $R_O$ , output capacitance interacts with the output impedance ( $Z_O$ ) of the amplifier causing phase shift in the feedback loop of the amplifier reducing the phase margin. This reduction in the phase margin causes peaking in the frequency response and overshoot and ringing in the pulse response. Interaction with other parasitic elements can lead to further instability or ringing. Inserting  $R_O$  isolates the phase shift from the loop gain path and restores the phase margin; however  $R_O$  can limit the bandwidth slightly. Figure 49 shows a diagram of driving capacitive loads.

Figure 39 shows the test circuit and shows the recommended values of  $R_O$  versus capacitive loads,  $C_L$ . See Figure 40 for the frequency responses with various optimized values of  $R_O$  with  $C_L$ .

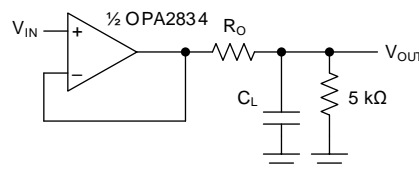

Figure 49. Driving Capacitive Loads With the OPA2834

## 8.4 Device Functional Modes

### 8.4.1 Split-Supply Operation ( $\pm 1.35 \text{ V}$ to $\pm 2.7 \text{ V}$ )

To facilitate testing with common lab equipment, the OPA2834EVM (see the [OPA2837DGK Evaluation Module user guide](#)) is built to allow split-supply operation. This configuration eases lab testing because the mid-point between the power rails is ground, and most signal generators, network analyzers, oscilloscopes, spectrum analyzers, and other lab equipment have inputs and outputs with a ground reference.

**Device Functional Modes (continued)**

Figure 50 shows a simple noninverting configuration analogous to Figure 45 with a  $\pm 2.5\text{-V}$  supply and the reference voltage ( $V_{REF}$ ) equal to ground. The input and output swing symmetrically around ground. For ease of use, split supplies are preferred in systems where signals swing around ground.

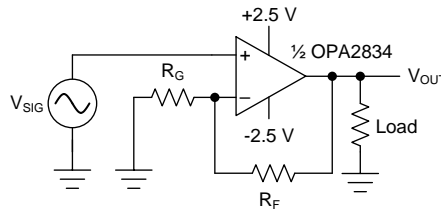
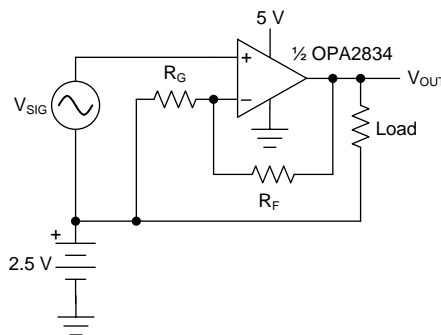

**Figure 50. Split-Supply Operation**

**8.4.2 Single-Supply Operation (2.7 V to 5.4 V)**

Often, newer systems use a single power supply to improve efficiency and reduce the cost of the power supply. The OPA2834 is designed for use with single-supply power operation and can be used with single-supply power with no change in performance from split supply, as long as the input and output are biased within the linear operation of the device.

To change the circuit from split-supply to single-supply, level shift all voltages by half the difference between the power-supply rails. For example, Figure 51 shows changing from a  $\pm 2.5\text{-V}$  split supply to a 5-V single supply.



**Figure 51. Single-Supply Concept**

A practical circuit has an amplifier or some other circuit providing the bias voltage for the input, and the output of this amplifier stage provides the bias for the next stage.

Figure 52 shows a typical noninverting amplifier circuit. With a 5-V single-supply, a mid-supply reference generator is needed to bias the negative side through  $R_G$ . To cancel the voltage offset that is otherwise caused by the input bias currents,  $R_1$  is selected to be equal to  $R_F$  in parallel with  $R_G$ . For example, if a gain of 2 is required and  $R_F = 3.6\text{ k}\Omega$ , select  $R_G = 3.6\text{ k}\Omega$  to set the gain, and  $R_1 = 1.8\text{ k}\Omega$  for bias current cancellation. The value for C is dependent on the reference, and TI recommends a value of at least  $0.1\text{ }\mu\text{F}$  to limit noise.

Device Functional Modes (continued)

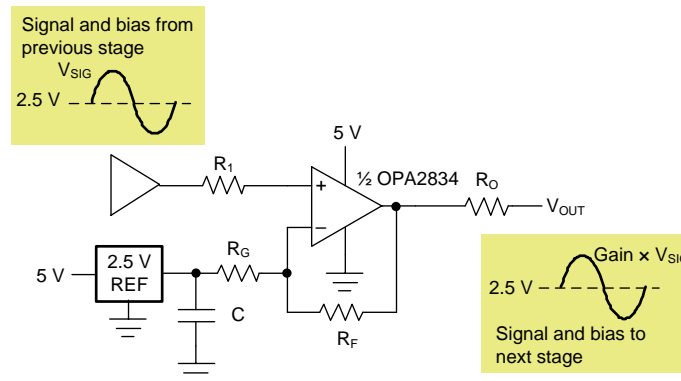

Figure 52. Noninverting Single-Supply Operation With Reference

Figure 53 illustrates a similar noninverting single-supply scenario with the reference generator replaced by the Thevenin equivalent using resistors and the positive supply.  $R_G'$  and  $R_G''$  form a resistor divider from the 5-V supply and are used to bias the negative side with the parallel sum equal to the equivalent  $R_G$  to set the gain. To cancel the voltage offset that is otherwise caused by the input bias currents,  $R_1$  is selected to be equal to  $R_F$  in parallel with  $R_G'$  in parallel with  $R_G''$  ( $R_1 = R_F \parallel R_G' \parallel R_G''$ ). For example, if a gain of 2 is required and  $R_F = 3.6 \text{ k}\Omega$ , selecting  $R_G' = R_G'' = 7.2 \text{ k}\Omega$  gives an equivalent parallel sum of  $3.6 \text{ k}\Omega$ , sets the gain to 2, and references the input to mid supply (2.5 V).  $R_1$  is set to  $1.8 \text{ k}\Omega$  for bias current cancellation. The resistor divider costs less than the 2.5-V reference in Figure 53 but can increase the current from the 5-V supply.

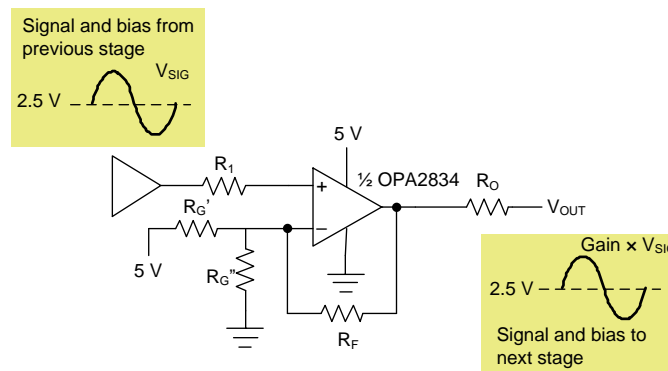

Figure 53. Noninverting Single-Supply Operation With Resistors

Figure 54 shows a typical inverting-amplifier circuit. With a 5-V single-supply, a mid-supply reference generator is needed to bias the positive side through  $R_1$ . To cancel the voltage offset that is otherwise caused by the input bias currents,  $R_1$  is selected to be equal to  $R_F$  in parallel with  $R_G$ . For example, if a gain of  $-2$  is required and  $R_F = 3.6 \text{ k}\Omega$ , select  $R_G = 1.8 \text{ k}\Omega$  to set the gain and  $R_1 = 1.2 \text{ k}\Omega$  for bias current cancellation. The value for  $C$  is dependent on the reference, but TI recommends a value of at least  $0.1 \text{ }\mu\text{F}$  to limit noise into the op amp.

**Device Functional Modes (continued)**

**Figure 54. Inverting Single-Supply Operation With Reference**

Figure 55 illustrates a similar inverting single-supply scenario with the reference generator replaced by the Thevenin equivalent using resistors and the positive supply.  $R_1$  and  $R_2$  form a resistor divider from the 5-V supply and are used to bias the positive side. To cancel the voltage offset that is otherwise caused by the input bias currents, set the parallel sum of  $R_1$  and  $R_2$  equal to the parallel sum of  $R_F$  and  $R_G$ .  $C$  must be added to limit the coupling of noise into the positive input. For example, if a gain of  $-2$  is required and  $R_F = 3.6\text{ k}\Omega$ , select  $R_G = 1.8\text{ k}\Omega$  to set the gain.  $R_1 = R_2 = 2.4\text{ k}\Omega$  for the mid-supply voltage bias and for op-amp input-bias current cancellation. A good value for  $C$  is  $0.1\text{ }\mu\text{F}$ . The resistor divider costs less than the 2.5-V reference in Figure 55 but can increase the current from the 5-V supply.

**Figure 55. Inverting Single-Supply Operation With Resistors**

## 9 Application and Implementation

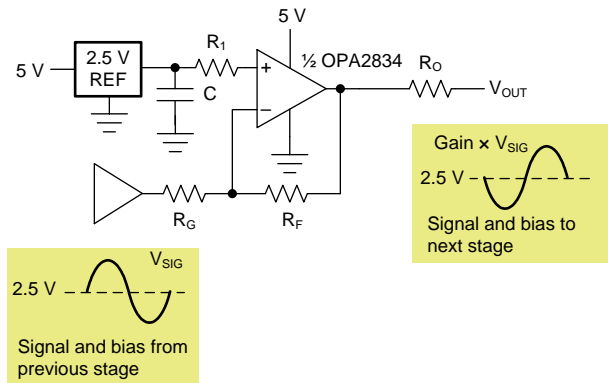
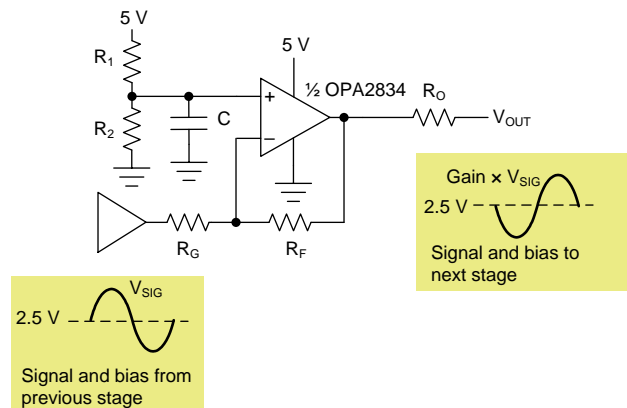
### NOTE

Information in the following applications sections is not part of the TI component specification, and TI does not warrant its accuracy or completeness. TI's customers are responsible for determining suitability of components for their purposes. Customers should validate and test their design implementation to confirm system functionality.

## 9.1 Application Information

### 9.1.1 Noninverting Amplifier

The OPA2834 can be used as a noninverting amplifier with a signal input to the noninverting input,  $V_{IN+}$ . Figure 45 illustrates a basic block diagram of the circuit.

The amplifier output can be calculated according to Equation 1 if  $V_{IN} = V_{REF} + V_{SIG}$ .

$$V_{OUT} = V_{SIG} \left( 1 + \frac{R_F}{R_G} \right) + V_{REF} \quad (1)$$

$$G = 1 + \frac{R_F}{R_G}$$

The signal gain of the circuit is set by  $\frac{R_F}{R_G}$ , and  $V_{REF}$  provides a reference around which the input and output signals swing. Output signals are in-phase with the input signals.

The OPA2834 is designed for the nominal value of  $R_F$  to be 3.6 k $\Omega$  in gains other than +1. This value gives excellent distortion performance, maximum bandwidth, best flatness, and best pulse response.  $R_F = 3.6$  k $\Omega$  must be used as a default unless other design goals require changing to other values. All test circuits used to collect data for this document have  $R_F = 3.6$  k $\Omega$  for all gains other than +1. A gain of +1 is a special case where  $R_F$  is shorted and  $R_G$  is left open.

### 9.1.2 Inverting Amplifier

The OPA2834 can be used as an inverting amplifier with a signal input to the inverting input,  $V_{IN-}$ , through the gain-setting resistor  $R_G$ . Figure 46 illustrates a basic block diagram of the circuit.

The output of the amplifier can be calculated according to Equation 2 if  $V_{IN} = V_{REF} + V_{SIG}$ .

$$V_{OUT} = V_{SIG} \left( \frac{-R_F}{R_G} \right) + V_{REF} \quad (2)$$

$$G = \frac{-R_F}{R_G}$$

The signal gain of the circuit is given by  $\frac{-R_F}{R_G}$  and  $V_{REF}$  provides a reference point around which the input and output signals swing. Output signals are 180° out-of-phase with the input signals. The nominal value of  $R_F$  must be 3.6 k $\Omega$  for inverting gains.

## 9.2 Typical Applications

### 9.2.1 Low-Side Current Sensing

Power stages use current feedback for phase current control and regulation. One of the commonly used methods for this current measurement is low-side current shunt monitoring. Figure 56 shows a representative schematic of such a system. The use of the OPA2834 is described in this section for a low-side, current-shunt monitoring application.

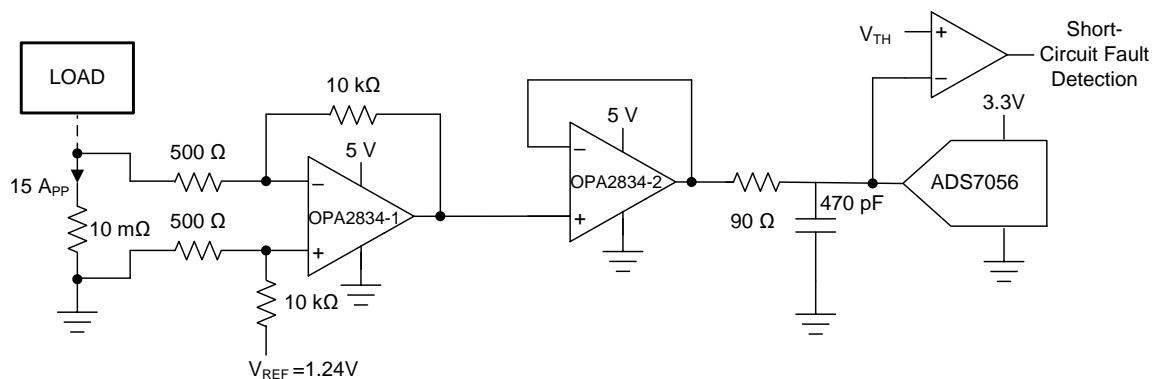

Figure 56. Low-Side Current Sensing

## Typical Applications (continued)

### 9.2.1.1 Design Requirements

The OPA2834 is used in a gain of 20 V/V followed by an OPA2834 used in a gain of 1 V/V for driving the input of the [ADS7056](#) which is sampling at 1 MSPS. A comparator is connected to the ADC input for short-circuit fault detection. This design example is illustrated for the following specifications:

- Switching frequency: 50 kHz
- Shunt resistance: 10 mΩ
- Load current: 15 A<sub>PP</sub>
- Output voltage: 3.0 V<sub>PP</sub>
- Amplifier supply voltage: 5 V
- Data Acquisition: 1 MSPS with 0.1% accuracy
- Input spikes due to inductive kickbacks from the power plane: 10 V

### 9.2.1.2 Detailed Design Procedure

One of the channels of the OPA2834 is connected to the shunt resistor in [Figure 56](#) in a 20-V/V difference amplifier configuration. [Equation 3](#) gives the gain of this circuit. A well-known way to start the design of this signal chain is to start from fixating the value of R<sub>G</sub>.

$$V_{OUT} = \left( \frac{R_F}{R_G} \right) (V_2 - V_1)$$

where

- R<sub>F</sub> and R<sub>G</sub> are the feedback and gain resistors for channel A of the OPA2834 (3)

The values of R<sub>F</sub> and R<sub>G</sub> depend on multiple factors. Using small resistors in the feedback network helps reduce output noise and improves measurement accuracy. Small feedback resistors result in larger power dissipation in the amplifier output stage. In order to reduce this power dissipation, large-value resistors reduce the phase margin and cause gain peaking; see [Figure 47](#). Select the values of R<sub>F</sub> and R<sub>G</sub> from the recommended range of values for this device. As given in [Equation 4](#), care must be taken to use a gain-resistor value large enough to limit the current through the input ESD diodes to within 10 mA for a 10-V input transient (as per the design targets) with the amplifier powered off a 5-V supply.

$$R_G = \frac{V_{IN} - V_D - V_S}{I_{D,Max}}$$

where

- V<sub>IN</sub> is the input transient voltage
- V<sub>D</sub> is the ESD diode forward voltage drop
- I<sub>D</sub> is the current resulting from this input transient flowing through the ESD diode (4)

A total gain of 20 V/V is required from the amplifier signal chain. We have chosen R<sub>G</sub> = 500 Ω in this design, thus R<sub>F</sub> = 10 kΩ. A SAR ADC features a sampling capacitor at the input pin. At the end of every conversion cycle, the circuit driving this SAR ADC needs to replenish this capacitor. Using the [analog calculator](#), the required bandwidth for the amplifier to drive the ADS7056 ( sampling rate of 1MSPS and a clock frequency of 40 MHz ) comes out to be at least 5 MHz. Because of this requirement, the two amplifier channels are configured in gains of 20 V/V and 1 V/V, respectively. The effective bandwidth of the amplifier set in a gain on 20 V/V comes out to be 20MHz/20 = 1MHz. The bandwidth of the second amplifier set in a gain of 1V/V , equals 50MHz. Thus the rise time and the settling time of the entire signal chain is decided by the first amplifier. Using an amplifier in the first stage of any lower bandwidth will result in a penalty in the settling time on the ADC. The 1.24-V reference voltage to the noninverting input of channel 1 sets the output common-mode voltage to 1.24 V. The two channels of the OPA2834 together provide a signal gain of 20 V/V. The first Amplifier's bandwidth is dedicated to gaining up the signal with a very low rise time whereas the function of the second amplifier is to utilize its bandwidth to drive the SAR ADC to achieve the required settling.

## Typical Applications (continued)

The ADS7056 samples at 1 MSPS with a 40-MHz clock which translates to an acquisition time of 550 nsec. This provides the dual amplifier 550 nsec to settle to the required accuracy. In this application, we target an accuracy of 0.1%. As the ADC is powered from a 3.3 V supply we have assumed the full scale to be 3 V.

An accuracy of 0.1% of 3 V = 3 mV. Thus the second OPA2834 should settle to  $\pm 3$  mV of its final intended value within 550 nsec. Figure 57 shows the TINA simulation plots for the OPA2834 driving the ADS7056. Input voltage (red) is the signal swing across the shunt resistance, the error signal is the % error in the voltage across the sampling capacitor from its steady-state value (instantaneous value - final value). The input signal sharply transits from its lowermost point to the uppermost point at 600 nsec instant. This can be considered as a short circuit event or step increase due to a mosfet switching in real-world circuits. This acquisition window of the ADC as discussed earlier is 550 nsec. The details on how this time is decided by the ADC can be found from the ADS7056 datasheet. Thus the % error signal (blue) must settle down to less than 0.1 % before the end of this 550 nsec window. The output signal (black) is divided by 20 V/V so as to be shown beside its corresponding input signal. As per Figure 57 the error signal comfortably settles to the final value with an error % of -0.05% which is well within the 0.1% accuracy. Hence the dual OPA2834 settles to 0.1% accuracy within 550 ns with a worst-case, 0 to 3-V full-scale transient output that too in a gain configuration of 20 V/V as shown in the Figure 57. OPA2834 enables single sample settling for ADS7056 running at 40 MHz clock with 1 MSPS.

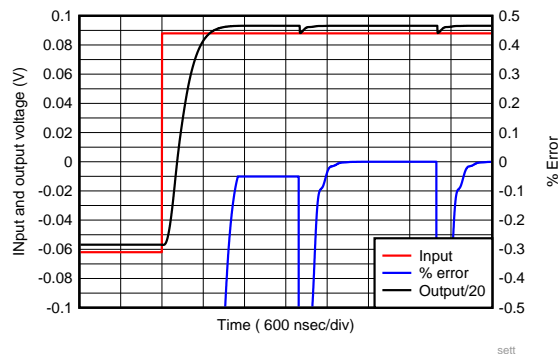

Figure 57. OPA2834 Settling Performance With the ADS7056

Another way to look at the signal chain is using the SNR and THD numbers. A 2 kHz tone is input to the first OPA2834 shown in Figure 56. This signal is gained up by 20 V/V and fed to the ADS7056. The results are compared to the specifications given in the ADS7056 datasheet.

Table 1. OPA2834 based signal-chain comparison

Parameter	OPA2834 + ADS7056	Ideal Opamp + ADS7056
ENOB	11.2	12.16
SNR (dB)	69.3	75.15
THD (dB)	-87.89	-90.13

Using a slower clock with the ADC and the same sampling rate causes the ENOB to reduce as the amplifier has reduced time available to settle. This reduction in ENOB is restored with a lower sampling frequency or use of wider bandwidth amplifiers from the OPA83x family of products.

### 9.2.2 Field Transmitter Sensor Interface

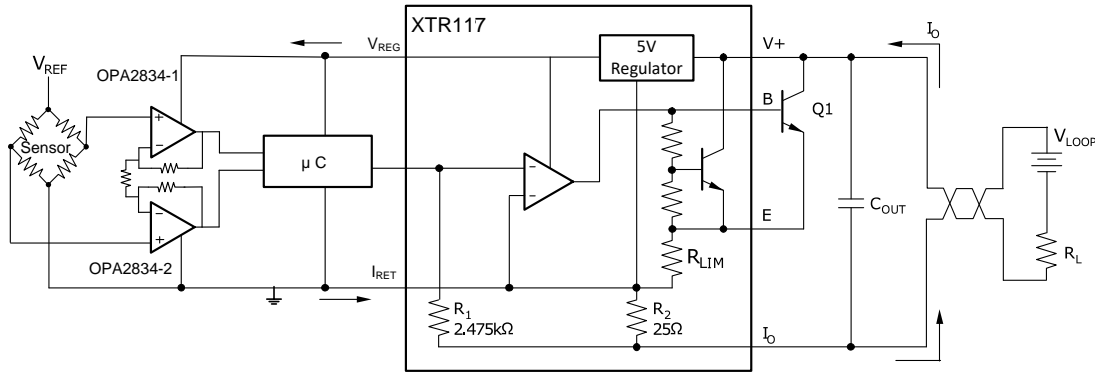

Figure 58. Field Transmitter Sensor Interface Block Diagram

### 9.2.3 Ultrasonic Flow Meters

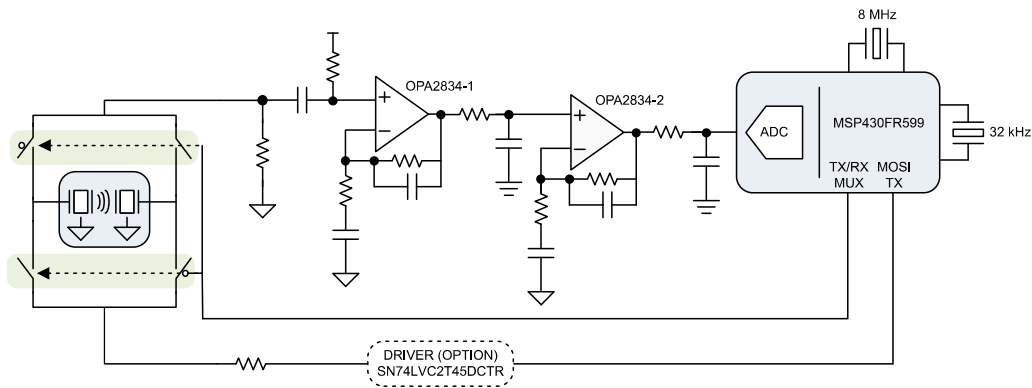

Figure 59. Ultrasonic Flow Meters Gain Stage

### 9.2.4 Microphone Pre-Amplifier

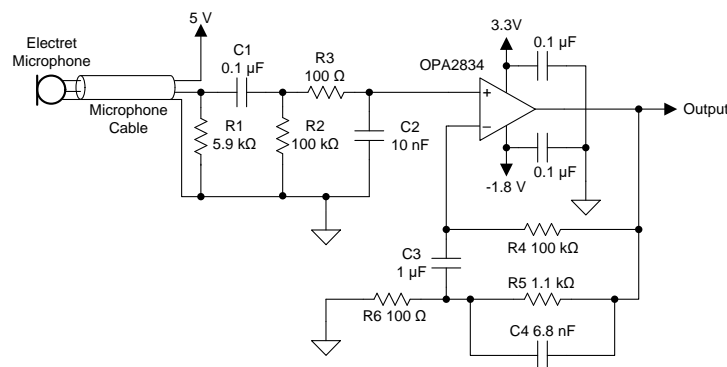

Figure 60. Low-Power Microphone Pre-Amplifier



Figure 60 shows an example circuit of the audio pre-amplifier application using OPA2834. The excellent distortion performance and the ultra-low quiescent current, make OPA2834 a very attractive solution for the portable and handheld audio instruments. Figure 60 circuit is a bandpass filter with frequency cutoff at 5 Hz and 180 kHz. The OPA2834 is connected to a positive 3.3 V and a negative 1.8 V supply. the primary reason for the skew in the power supply is to enable the maximum dynamic range possible to the user. The  $V_{ICR}$  of OPA2834 mentioned in *Electrical Characteristics: 3V to 5V* is 1.1 V from the positive rail. Thus having a skewed power supply like in Figure 60 gives a common-mode input range from -2 V up to 2.2 V.

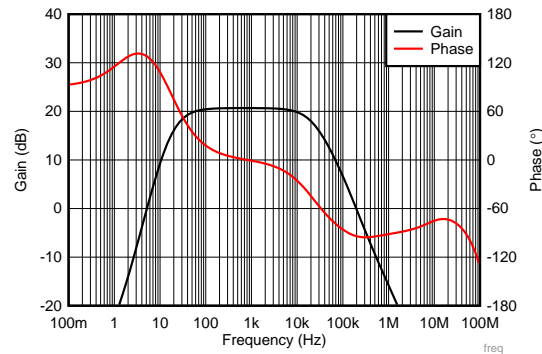

Figure 61. Frequency Response of Microphone Pre-Amplifier

## 10 Power Supply Recommendations

The OPA2834 is intended to work in a nominal supply range of 3.0 V to 5.0 V. Supply-voltage tolerances are supported with the specified operating range of 2.7 V (–10% on a 3-V supply) and 5.4 V (8% on a 5-V supply). Good power-supply bypassing is required. Minimize the distance (< 0.1 inch) from the power-supply pins to high-frequency, 0.1- $\mu$ F decoupling capacitors. A larger capacitor (2.2  $\mu$ F is typical) is used along with a high-frequency, 0.1- $\mu$ F, supply-decoupling capacitor at the device supply pins. For single-supply operation, only the positive supply has these capacitors. When a split supply is used, use these capacitors for each supply to ground. If necessary, place the larger capacitors further from the device and share these capacitors among several devices in the same area of the printed circuit board (PCB). Avoid narrow power and ground traces to minimize inductance between the pins and the decoupling capacitors. An optional supply decoupling capacitor across the two power supplies (for bipolar operation) reduces second-order harmonic distortion.

## 11 Layout

### 11.1 Layout Guidelines

The [OPA2837EVM](#) can be used as a reference when designing the circuit board. TI recommends following the EVM layout of the external components near to the amplifier, ground plane construction, and power routing as closely as possible. Follow these general guidelines:

1. Signal routing must be direct and as short as possible into and out of the op amp.
2. The feedback path must be short and direct avoiding vias if possible, especially with  $G = 1$  V/V.
3. Ground or power planes must be removed from directly under the negative input and output pins of the amplifier.
4. TI recommends placing a series output resistor as close to the output pin as possible.
5. See [Figure 40](#) for recommended values for the expected capacitive load. These values are derived targeting a  $30^\circ$  phase margin to the output of the op amp.
6. A 2.2- $\mu$ F power-supply decoupling capacitor must be placed within two inches of the device and can be shared with other op amps. For split supply, a capacitor is required for both supplies.
7. A 0.1- $\mu$ F power-supply decoupling capacitor must be placed as close to the supply pins as possible, preferably within 0.1 inch. For split supply, a capacitor is required for both supplies.

### 11.2 Layout Examples

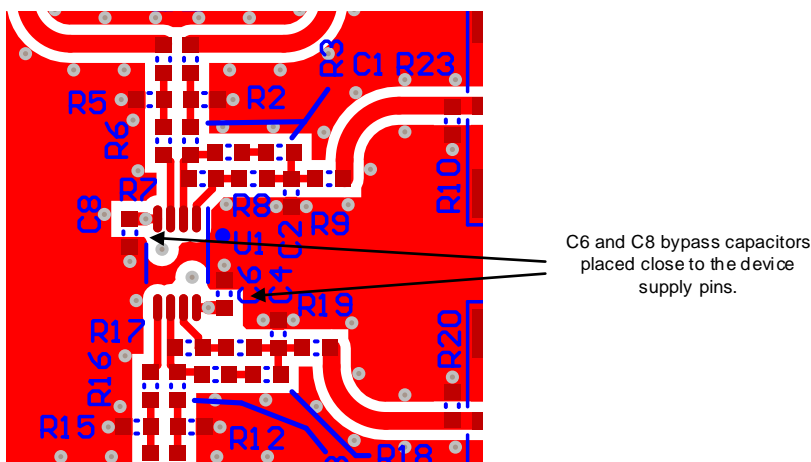

Figure 62. EVM Layout Top Layer

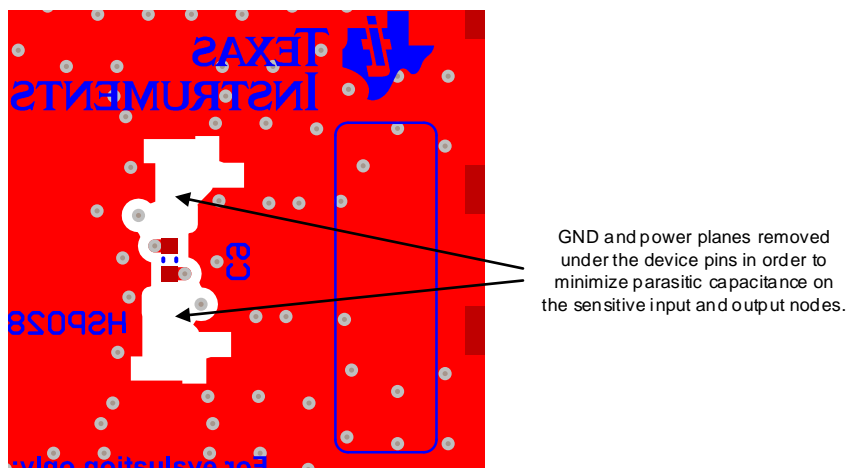

Figure 63. EVM Layout Bottom Layer

## 12 Device and Documentation Support

### 12.1 Documentation Support

#### 12.1.1 Related Documentation

For related documentation see the following:

- Texas Instruments, [OPA2837DGK Evaluation Module user guide](#)
- Texas Instruments, [ADS7046 12-Bit, 3-MSPS, Single-Ended Input, Small-Size, Low-Power SAR ADC data sheet](#)
- Texas Instruments, [Single-Supply Op Amp Design Techniques application report](#)
- Texas Instruments, [Noise Analysis for High-Speed Op Amps application report](#)
- Texas Instruments, [TIDA-01565 Wired OR MUX and PGA Reference Design design guide](#)
- Texas Instruments, [TINA model and simulation tool](#)

#### 12.2 Receiving Notification of Documentation Updates

To receive notification of documentation updates, navigate to the device product folder on ti.com. In the upper right corner, click on *Alert me* to register and receive a weekly digest of any product information that has changed. For change details, review the revision history included in any revised document.

#### 12.3 Community Resources

[TI E2E™ support forums](#) are an engineer's go-to source for fast, verified answers and design help — straight from the experts. Search existing answers or ask your own question to get the quick design help you need.

Linked content is provided "AS IS" by the respective contributors. They do not constitute TI specifications and do not necessarily reflect TI's views; see TI's [Terms of Use](#).

#### 12.4 Trademarks

E2E is a trademark of Texas Instruments.

All other trademarks are the property of their respective owners.

#### 12.5 Electrostatic Discharge Caution



This integrated circuit can be damaged by ESD. Texas Instruments recommends that all integrated circuits be handled with appropriate precautions. Failure to observe proper handling and installation procedures can cause damage.

ESD damage can range from subtle performance degradation to complete device failure. Precision integrated circuits may be more susceptible to damage because very small parametric changes could cause the device not to meet its published specifications.

#### 12.6 Glossary

[SLYZ022](#) — *TI Glossary*.

This glossary lists and explains terms, acronyms, and definitions.

## 13 Mechanical, Packaging, and Orderable Information

The following pages include mechanical, packaging, and orderable information. This information is the most current data available for the designated devices. This data is subject to change without notice and revision of this document. For browser-based versions of this data sheet, refer to the left-hand navigation.

## PACKAGING INFORMATION

Orderable part number	Status (1)	Material type (2)	Package   Pins	Package qty   Carrier	RoHS (3)	Lead finish/ Ball material (4)	MSL rating/ Peak reflow (5)	Op temp (°C)	Part marking (6)
<a href="#">OPA2834IDGKR</a>	Active	Production	VSSOP (DGK)   8	2500   LARGE T&R	Yes	NIPDAU   SN   NIPDAUAG	Level-2-260C-1 YEAR	-40 to 125	2834
OPA2834IDGKR.B	Active	Production	VSSOP (DGK)   8	2500   LARGE T&R	Yes	NIPDAU	Level-2-260C-1 YEAR	-40 to 125	2834
<a href="#">OPA2834IDGKT</a>	Active	Production	VSSOP (DGK)   8	250   SMALL T&R	Yes	NIPDAU   SN   NIPDAUAG	Level-2-260C-1 YEAR	-40 to 125	2834
OPA2834IDGKT.B	Active	Production	VSSOP (DGK)   8	250   SMALL T&R	Yes	NIPDAU	Level-2-260C-1 YEAR	-40 to 125	2834

(1) **Status:** For more details on status, see our [product life cycle](#).

(2) **Material type:** When designated, preproduction parts are prototypes/experimental devices, and are not yet approved or released for full production. Testing and final process, including without limitation quality assurance, reliability performance testing, and/or process qualification, may not yet be complete, and this item is subject to further changes or possible discontinuation. If available for ordering, purchases will be subject to an additional waiver at checkout, and are intended for early internal evaluation purposes only. These items are sold without warranties of any kind.

(3) **RoHS values:** Yes, No, RoHS Exempt. See the [TI RoHS Statement](#) for additional information and value definition.

(4) **Lead finish/Ball material:** Parts may have multiple material finish options. Finish options are separated by a vertical ruled line. Lead finish/Ball material values may wrap to two lines if the finish value exceeds the maximum column width.

(5) **MSL rating/Peak reflow:** The moisture sensitivity level ratings and peak solder (reflow) temperatures. In the event that a part has multiple moisture sensitivity ratings, only the lowest level per JEDEC standards is shown. Refer to the shipping label for the actual reflow temperature that will be used to mount the part to the printed circuit board.

(6) **Part marking:** There may be an additional marking, which relates to the logo, the lot trace code information, or the environmental category of the part.

Multiple part markings will be inside parentheses. Only one part marking contained in parentheses and separated by a "-" will appear on a part. If a line is indented then it is a continuation of the previous line and the two combined represent the entire part marking for that device.

**Important Information and Disclaimer:** The information provided on this page represents TI's knowledge and belief as of the date that it is provided. TI bases its knowledge and belief on information provided by third parties, and makes no representation or warranty as to the accuracy of such information. Efforts are underway to better integrate information from third parties. TI has taken and continues to take reasonable steps to provide representative and accurate information but may not have conducted destructive testing or chemical analysis on incoming materials and chemicals. TI and TI suppliers consider certain information to be proprietary, and thus CAS numbers and other limited information may not be available for release.

In no event shall TI's liability arising out of such information exceed the total purchase price of the TI part(s) at issue in this document sold by TI to Customer on an annual basis.

**TAPE AND REEL INFORMATION**

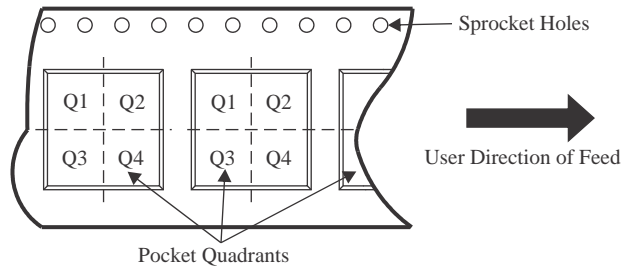
**QUADRANT ASSIGNMENTS FOR PIN 1 ORIENTATION IN TAPE**

\*All dimensions are nominal

Device	Package Type	Package Drawing	Pins	SPQ	Reel Diameter (mm)	Reel Width W1 (mm)	A0 (mm)	B0 (mm)	K0 (mm)	P1 (mm)	W (mm)	Pin1 Quadrant
OPA2834IDGKR	VSSOP	DGK	8	2500	330.0	12.4	5.3	3.4	1.4	8.0	12.0	Q1
OPA2834IDGKR	VSSOP	DGK	8	2500	330.0	12.4	5.25	3.35	1.25	8.0	12.0	Q1
OPA2834IDGKT	VSSOP	DGK	8	250	330.0	12.4	5.3	3.4	1.4	8.0	12.0	Q1
OPA2834IDGKT	VSSOP	DGK	8	250	330.0	12.4	5.25	3.35	1.25	8.0	12.0	Q1

**TAPE AND REEL BOX DIMENSIONS**

\*All dimensions are nominal

Device	Package Type	Package Drawing	Pins	SPQ	Length (mm)	Width (mm)	Height (mm)
OPA2834IDGKR	VSSOP	DGK	8	2500	353.0	353.0	32.0
OPA2834IDGKR	VSSOP	DGK	8	2500	366.0	364.0	50.0
OPA2834IDGKT	VSSOP	DGK	8	250	353.0	353.0	32.0
OPA2834IDGKT	VSSOP	DGK	8	250	366.0	364.0	50.0

# DGK0008A

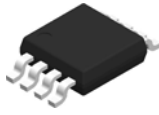

# PACKAGE OUTLINE

VSSOP - 1.1 mm max height

SMALL OUTLINE PACKAGE

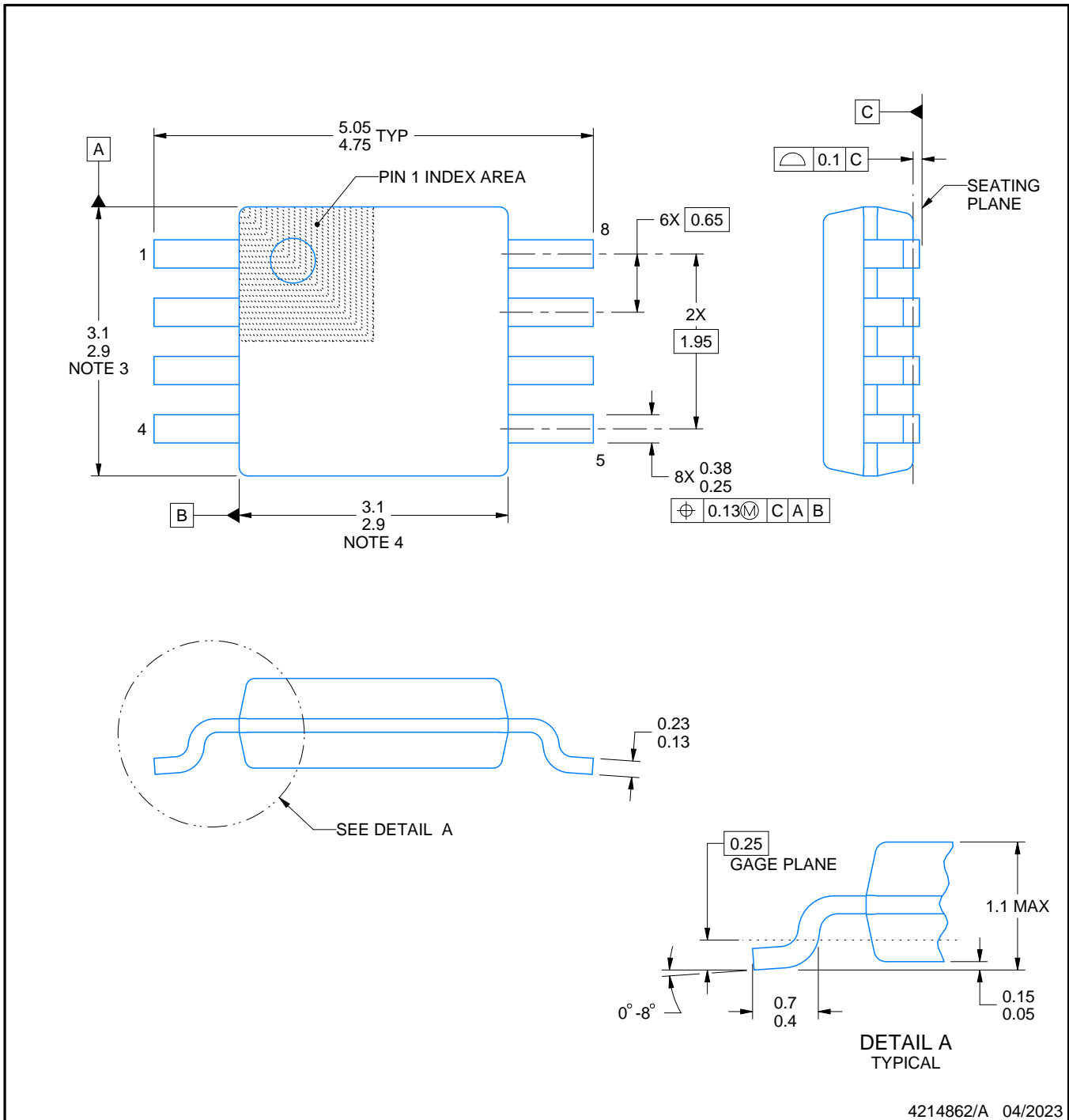

**NOTES:**

PowerPAD is a trademark of Texas Instruments.

1. All linear dimensions are in millimeters. Any dimensions in parenthesis are for reference only. Dimensioning and tolerancing per ASME Y14.5M.
2. This drawing is subject to change without notice.
3. This dimension does not include mold flash, protrusions, or gate burrs. Mold flash, protrusions, or gate burrs shall not exceed 0.15 mm per side.
4. This dimension does not include interlead flash. Interlead flash shall not exceed 0.25 mm per side.
5. Reference JEDEC registration MO-187.

# EXAMPLE BOARD LAYOUT

DGK0008A

<sup>TM</sup> VSSOP - 1.1 mm max height

SMALL OUTLINE PACKAGE

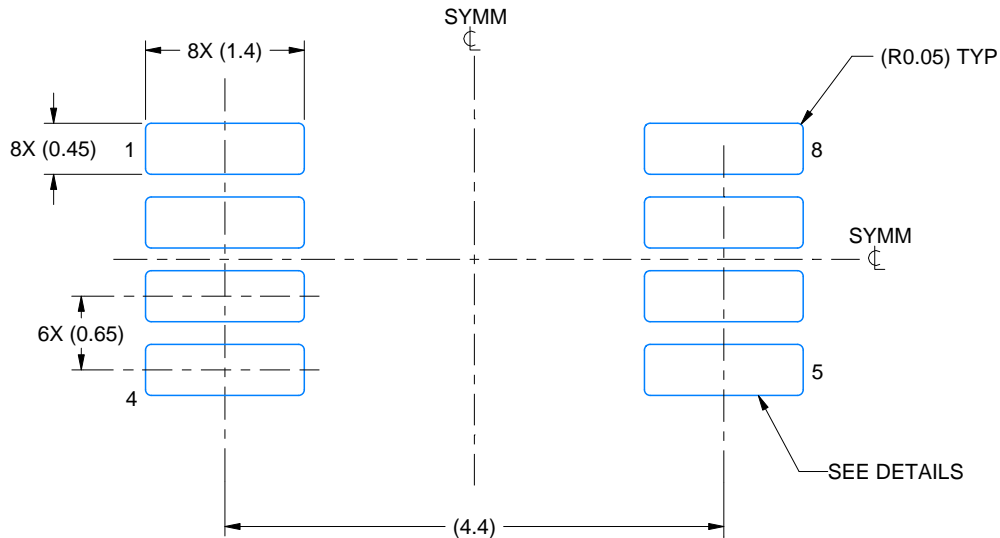

LAND PATTERN EXAMPLE  
EXPOSED METAL SHOWN  
SCALE: 15X

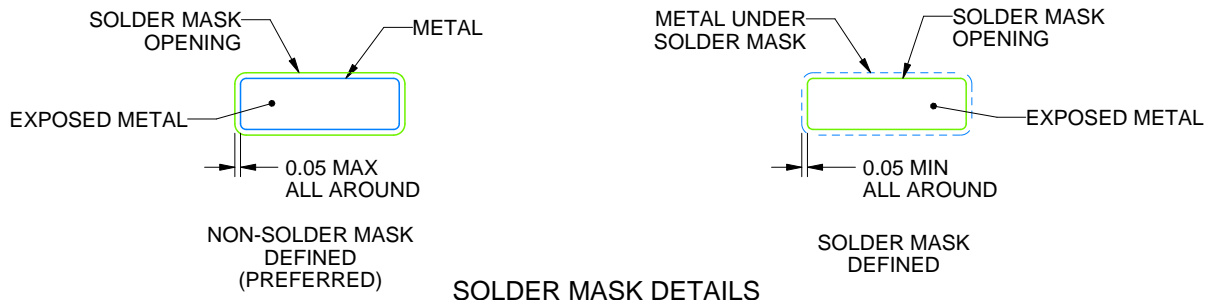

SOLDER MASK DETAILS

4214862/A 04/2023

NOTES: (continued)

6. Publication IPC-7351 may have alternate designs.
7. Solder mask tolerances between and around signal pads can vary based on board fabrication site.
8. Vias are optional depending on application, refer to device data sheet. If any vias are implemented, refer to their locations shown on this view. It is recommended that vias under paste be filled, plugged or tented.
9. Size of metal pad may vary due to creepage requirement.



# EXAMPLE STENCIL DESIGN

DGK0008A

<sup>TM</sup> VSSOP - 1.1 mm max height

SMALL OUTLINE PACKAGE

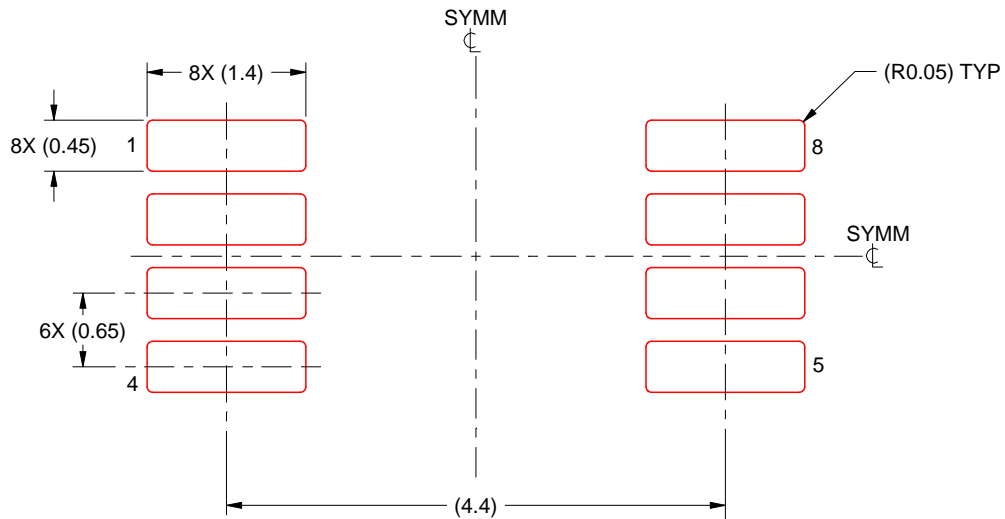

SOLDER PASTE EXAMPLE  
SCALE: 15X

4214862/A 04/2023

NOTES: (continued)

11. Laser cutting apertures with trapezoidal walls and rounded corners may offer better paste release. IPC-7525 may have alternate design recommendations.
12. Board assembly site may have different recommendations for stencil design.

## IMPORTANT NOTICE AND DISCLAIMER

TI PROVIDES TECHNICAL AND RELIABILITY DATA (INCLUDING DATASHEETS), DESIGN RESOURCES (INCLUDING REFERENCE DESIGNS), APPLICATION OR OTHER DESIGN ADVICE, WEB TOOLS, SAFETY INFORMATION, AND OTHER RESOURCES "AS IS" AND WITH ALL FAULTS, AND DISCLAIMS ALL WARRANTIES, EXPRESS AND IMPLIED, INCLUDING WITHOUT LIMITATION ANY IMPLIED WARRANTIES OF MERCHANTABILITY, FITNESS FOR A PARTICULAR PURPOSE OR NON-INFRINGEMENT OF THIRD PARTY INTELLECTUAL PROPERTY RIGHTS.

These resources are intended for skilled developers designing with TI products. You are solely responsible for (1) selecting the appropriate TI products for your application, (2) designing, validating and testing your application, and (3) ensuring your application meets applicable standards, and any other safety, security, regulatory or other requirements.

These resources are subject to change without notice. TI grants you permission to use these resources only for development of an application that uses the TI products described in the resource. Other reproduction and display of these resources is prohibited. No license is granted to any other TI intellectual property right or to any third party intellectual property right. TI disclaims responsibility for, and you fully indemnify TI and its representatives against any claims, damages, costs, losses, and liabilities arising out of your use of these resources.

TI's products are provided subject to [TI's Terms of Sale](#), [TI's General Quality Guidelines](#), or other applicable terms available either on [ti.com](#) or provided in conjunction with such TI products. TI's provision of these resources does not expand or otherwise alter TI's applicable warranties or warranty disclaimers for TI products. Unless TI explicitly designates a product as custom or customer-specified, TI products are standard, catalog, general purpose devices.

TI objects to and rejects any additional or different terms you may propose.

Copyright © 2025, Texas Instruments Incorporated

Last updated 10/2025