

24-BIT, 96-kHz STEREO AUDIO CODEC WITH MICROPHONE AMPLIFIER, BIAS, MULTIPLEXER, AND PGA

FEATURES

- **Microphone Amplifier and Bias**
 - Monaural Microphone Amplifier: 34-dB Gain at Differential Input
 - Microphone Bias: 1 mA at 3.75 V
- **Multiplexer and PGA**
 - Multiplex of Stereo Single-Ended Line Inputs and Monaural Microphone Amplifier
 - 0.1 V_{rms} to 1.5 V_{rms} Full-Scale Input Range
 - 22-k Ω Input Resistance at 0.1-V_{rms} Input
 - 20 dB to –4 dB/range, 1 dB/step PGA
- **Reference Output: ± 10 mA at 2.5 V**
- **24-Bit Delta-Sigma ADC and DAC**
- **Stereo ADC:**
 - Full-Scale Input: 3 V_{p-p}
 - Antialiasing Filter Included
 - 1/64 Decimation Filter:
 - Pass-Band Ripple: ± 0.05 dB
 - Stop-Band Attenuation: –65 dB
 - On-Chip High-Pass Filter: 0.91 Hz at $f_s = 48$ kHz
 - High Performance:
 - THD+N: –94 dB (Typical)
 - SNR: 101 dB (Typical)
 - Dynamic Range: 101 dB (Typical)
- **Stereo DAC:**
 - Single-Ended Voltage Output: 4 V_{p-p}
 - Analog Low-Pass Filter Included
 - $\times 8$ Oversampling Digital Filter:
 - Pass-Band Ripple: ± 0.03 dB
 - Stop-Band Attenuation: –50 dB
 - High Performance:
 - THD+N: –97 dB (Typical)
 - SNR: 105 dB (Typical)
 - Dynamic Range: 104 dB (Typical)
- **S/PDIF Output for DAC Digital Input**
- **Multiple Functions With I²C Interface:**
 - Digital De-Emphasis: 32-, 44.1-, 48-kHz
 - Zipper-Noise-Free Digital Attenuation and Soft Mute for DAC
 - HPF Bypass Control for ADC
 - S/PDIF Output Control
 - Power Down: ADC/DAC Independently
- **External Power-Down Pin:**
 - ADC/DAC Simultaneously
- **Audio Data Format: 24-Bit I²S Only**
- **Sampling Rate:**
 - 16–96 kHz for Both ADC and DAC
- **System Clock: 256 f_s Only**
- **Dual Power Supplies:**
 - 5 V for Analog and 3.3 V for Digital
- **Package: VQFN-32**

DESCRIPTION

The PCM3052A is a low-cost, single-chip, 24-bit stereo audio codec (ADC and DAC) with single-ended analog voltage input and output. It also has an analog front end consisting of a 34-dB microphone amplifier, microphone bias generator, 2 stereo multiplexers, and a wide-range PGA. Analog-to-digital converters (ADCs) employ delta-sigma modulation with 64-times oversampling. On the other hand, digital-to-analog converters (DACs) employ modulation with 64- and 128-times oversampling. ADCs include a digital decimation filter with a high-pass filter, and DACs include an 8-times oversampling digital interpolation filter. The PCM3052A has many functions which are controlled using the I²C interface: DAC digital de-emphasis, digital attenuation, soft mute etc. The PCM3052A also has an S/PDIF output pin for the DAC digital input. The power-down mode, which works on ADCs and DACs simultaneously, is provided by an external pin. The PCM3052A is suitable for a wide variety of cost-sensitive PC audio (recorder and player) applications where good performance is required. The PCM3052A is fabricated using a highly advanced CMOS process and is available in a small 32-pin VQFN package.



Please be aware that an important notice concerning availability, standard warranty, and use in critical applications of Texas Instruments semiconductor products and disclaimers thereto appears at the end of this data sheet.

System Two, Audio Precision are trademarks of Audio Precision, Inc.
All trademarks are the property of their respective owners.



This integrated circuit can be damaged by ESD. Texas Instruments recommends that all integrated circuits be handled with appropriate precautions. Failure to observe proper handling and installation procedures can cause damage.

ESD damage can range from subtle performance degradation to complete device failure. Precision integrated circuits may be more susceptible to damage because very small parametric changes could cause the device not to meet its published specifications.

ABSOLUTE MAXIMUM RATINGS

over operating free-air temperature range (unless otherwise noted)⁽¹⁾

		PCM3052A
Supply voltage	$V_{CC1}, V_{CC2}, V_{CC3}$	–0.3 V to 6.5 V
	V_{DD}	–0.3 V to 4 V
Supply voltage differences	$V_{CC1}, V_{CC2}, V_{CC3}$	±0.1 V
Ground voltage differences	AGND1, AGND2, AGND3, DGND	±0.1 V
Digital input voltage	$\overline{PDWN}, DIN, SCKI, SDA, SCL, ADR, I2CEN$	–0.3 V to 6.5 V
	DOUT, LRCK, BCK, DOUTS	–0.3 V to $(V_{DD} + 0.3 V) < 4 V$
Analog input voltage	$V_{INL}, V_{INR}, V_{REF1}, V_{REF2}, REFO, ATEST, L\overline{M}, V_{OUTR}, V_{OUTL}, V_{COM}, MINP, MINM, MBIAS$	–0.3 V to $(V_{CC} + 0.3 V) < 6.5 V$
Input current (any pins except supplies)		±10 mA
Ambient temperature under bias		–40°C to 125°C
Storage temperature		–55°C to 150°C
Junction temperature		150°C
Lead temperature (soldering)		260°C, 5 s
Package temperature (reflow, peak)		260°C

(1) Stresses beyond those listed under *absolute maximum ratings* may cause permanent damage to the device. These are stress ratings only and functional operation of the device at these or any other conditions beyond those indicated under *recommended operating conditions* is not implied. Exposure to absolute-maximum-rated conditions for extended periods may affect device reliability.

RECOMMENDED OPERATING CONDITIONS

over operating free-air temperature range (unless otherwise noted)

		MIN	NOM	MAX	UNIT
V_{DD}	Digital supply voltage	3	3.3	3.6	V
V_{CC}	Analog supply voltage	4.5	5	5.5	V
	Digital input logic family	TTL compatible			
Digital input clock frequency	System clock	4		25	MHz
	Sampling clock	16		96	kHz
Analog input voltage	Line input, full scale, PGA = 0 dB		3		V _{p-p}
	Microphone input, full scale, PGA = 0 dB		30		mV _{p-p}
	Digital output load capacitance			20	pF
	Line output load resistance	5			kΩ
	Line output load capacitance			50	pF
	Microphone bias output load resistance	3.75			kΩ
	Reference output load resistance	250			Ω
T_A	Operating free-air temperature	–40		85	°C

ELECTRICAL CHARACTERISTICS

All specifications at $T_A = 25^\circ\text{C}$, $V_{CC1} = V_{CC2} = V_{CC3} = 5\text{ V}$, $V_{DD} = 3.3\text{ V}$, $f_S = 48\text{ kHz}$, $\text{SCKI} = 256 f_S$, 24-bit data, unless otherwise noted

PARAMETER		TEST CONDITIONS	MIN	TYP	MAX	UNIT
DIGITAL INPUT/OUTPUT – DATA FORMAT						
Audio data interface format			I ² S			
Audio data bit length			24			Bits
Audio data format			MSB-first, 2s complement			
f_S	Sampling frequency, ADC		16	48	96	kHz
	Sampling frequency, DAC		16	48	96	kHz
System clock frequency		$256 f_S$	4		25	MHz
INPUT LOGIC						
$V_{IH}^{(1)}$	Input logic level		2		V_{DD}	VDC
$V_{IL}^{(1)}$					0.8	
$V_{IH}^{(2)(3)}$	Input logic level		2		5.5	VDC
$V_{IL}^{(2)(3)}$					0.8	
$I_{IH}^{(2)}$	Input logic current	$V_{IN} = V_{DD}$			± 10	μA
$I_{IL}^{(2)}$		$V_{IN} = 0\text{ V}$			± 10	
$I_{IH}^{(1)(3)}$	Input logic current	$V_{IN} = V_{DD}$		65	100	μA
$I_{IL}^{(1)(3)}$		$V_{IN} = 0\text{ V}$			± 10	
OUTPUT LOGIC						
$V_{OH}^{(4)}$	Output logic level	$I_{OUT} = -4\text{ mA}$	2.8			VDC
$V_{OL}^{(4)(5)}$		$I_{OUT} = 4\text{ mA}$			0.5	
$V_{OH}^{(6)}$		$I_{OUT} = -0.3\text{ mA}$	4.5			VDC
$V_{OL}^{(6)}$		$I_{OUT} = 0.3\text{ mA}$			0.5	
MICROPHONE AMPLIFIER						
Input level		Single-ended		1	15	mVrms
Gain		Single-ended		40		dB
Input resistance		Single-ended	5	6		k Ω
Frequency response		-3 dB		20		kHz
SNR		1-kHz, 100-mVrms output		59		dB
THD+N		1-kHz, 1-Vrms output		-77		dB
MICROPHONE BIAS GENERATOR						
Output voltage		$I_{OUT} = -1\text{ mA}$	$0.75 V_{CC1}$ - 0.15	$0.75 V_{CC1}$	$0.75 V_{CC1}$ + 0.15	V
Output source current					1	mA
Output impedance				48		Ω
Output noise voltage		100 Hz–20 kHz, with 10- μF decoupling		1.8		μVrms
REFERENCE OUTPUT						
Output voltage		$I_{OUT} = \pm 10\text{ mA}$	$0.5 V_{CC1}$ - 0.15	$0.5 V_{CC1}$	$0.5 V_{CC1}$ + 0.15	V
Output source/sink current					10	mA
Output impedance				6		Ω
Output noise voltage		100 Hz–20 kHz, with 10- μF decoupling		1.8		μVrms

- (1) Pins 10, 11: LRCK, BCK (Schmitt-trigger input with 50-k Ω typical internal pulldown resistor)
- (2) Pins 12, 17, 18, 19, 21: DIN, SCKI, SDA, SCL, I2CEN (Schmitt-trigger input, 5-V tolerant)
- (3) Pins 9, 20 : $\overline{\text{PDWN}}$, ADR (Schmitt-trigger input with 50-k Ω typical internal pulldown resistor, 5-V tolerant).
- (4) Pins 13, 14: DOUT, DOUTS
- (5) Pin 18: SDA (Open-drain LOW output)
- (6) Pin 3: L/\overline{M}

ELECTRICAL CHARACTERISTICS (continued)

All specifications at $T_A = 25^\circ\text{C}$, $V_{CC1} = V_{CC2} = V_{CC3} = 5\text{ V}$, $V_{DD} = 3.3\text{ V}$, $f_S = 48\text{ kHz}$, $\text{SCKI} = 256 f_S$, 24-bit data, unless otherwise noted

PARAMETER		TEST CONDITIONS	MIN	TYP	MAX	UNIT
AFE MULTIPLEXER						
Input channel				2		CH
Input range for full scale		V_{INL}, V_{INR}	0.1	1	1.5	Vrms
Input Impedance		V_{INL}, V_{INR}	22	143		k Ω
Antialiasing filter frequency response		-3 dB, PGA gain = 0 dB		300		kHz
Input center voltage (VREF1)				$0.5 V_{CC1}$		V
AFE PGA						
Gain range			-4	0	20	dB
Gain step				1		dB
Monotonicity				Ensured		
ADC CHARACTERISTICS						
Resolution				24		Bits
Full-scale input voltage		V_{INL}, V_{INR} at PGA gain = 0 dB		$0.6 V_{CC1}$		Vp-p
DC Accuracy						
Gain mismatch, channel-to-channel		Full scale input, V_{INL}, V_{INR}		± 1	± 2	% of FSR
Gain error		Full scale input, V_{INL}, V_{INR}		± 2	± 4	% of FSR
Bipolar-zero error		HPF bypass, V_{INL}, V_{INR}		± 2		% of FSR
Dynamic Performance ⁽⁷⁾						
THD+N	Total harmonic distortion + noise	$f_S = 48\text{ kHz}, V_{IN} = -0.5\text{ dB}$		-94	-88	dB
		$f_S = 96\text{ kHz}, V_{IN} = -0.5\text{ dB}$		-89		
		$f_S = 48\text{ kHz}, V_{IN} = -60\text{ dB}$		-38		
		$f_S = 96\text{ kHz}, V_{IN} = -60\text{ dB}$		-38		
Dynamic range		$f_S = 48\text{ kHz}, \text{A-weighted}$	95	101		dB
		$f_S = 96\text{ kHz}, \text{A-weighted}$		101		
S/N	Signal-to-noise ratio	$f_S = 48\text{ kHz}, \text{A-weighted}$	95	101		dB
		$f_S = 96\text{ kHz}, \text{A-weighted}$		101		
Channel separation (between L-ch and R-ch of line-in)		$f_S = 48\text{ kHz}$	92	98		dB
		$f_S = 96\text{ kHz}$		99		
Channel separation (between microphone and line-in)		$f_S = 48\text{ kHz}$	92	98		dB
		$f_S = 96\text{ kHz}$		99		
Digital Filter Performance						
Pass band		$\pm 0.05\text{ dB}$			$0.454 f_S$	Hz
Stop band			$0.583 f_S$			Hz
Pass-band ripple					± 0.05	dB
Stop-band attenuation		$0.583 f_S$	-65			dB
Delay time				$17.4/f_S$		s
HPF frequency response		-3 dB		$0.019 f_S$		MHz
DAC CHARACTERISTICS						
Resolution				24		Bits
DC Accuracy						
Gain mismatch, channel-to-channel				± 1	± 2	% of FSR
Gain error				± 2	± 6	% of FSR
Bipolar zero error				± 1		% of FSR

(7) $f_{IN} = 1\text{ kHz}$, using System Two™ audio measurement system by Audio Precision™ in the RMS mode with 20-kHz LPF and 400-Hz HPF in the calculation, at PGA gain = 0 dB, for V_{INL} and V_{INR} .

ELECTRICAL CHARACTERISTICS (continued)

All specifications at $T_A = 25^\circ\text{C}$, $V_{CC1} = V_{CC2} = V_{CC3} = 5\text{ V}$, $V_{DD} = 3.3\text{ V}$, $f_S = 48\text{ kHz}$, $\text{SCKI} = 256 f_S$, 24-bit data, unless otherwise noted

PARAMETER		TEST CONDITIONS	MIN	TYP	MAX	UNIT
Dynamic Performance ⁽⁸⁾						
THD+N	Total harmonic distortion + noise	$f_S = 48\text{ kHz}$, $V_{OUT} = 0\text{ dB}$		-97	-90	dB
		$f_S = 96\text{ kHz}$, $V_{OUT} = 0\text{ dB}$		-99		
		$f_S = 48\text{ kHz}$, $V_{OUT} = -60\text{ dB}$		-42		
		$f_S = 96\text{ kHz}$, $V_{OUT} = -60\text{ dB}$		-43		
Dynamic range		$f_S = 48\text{ kHz}$, EIAJ, A-weighted	98	104		dB
		$f_S = 96\text{ kHz}$, EIAJ, A-weighted		106		
S/N	Signal-to-noise ratio	$f_S = 48\text{ kHz}$, EIAJ, A-weighted	99	105		dB
		$f_S = 96\text{ kHz}$, EIAJ, A-weighted		106		
Channel separation		$f_S = 48\text{ kHz}$	97	103		dB
		$f_S = 96\text{ kHz}$		104		
Analog Output						
Output voltage				$0.8 V_{CC2}$		Vp-p
Center voltage				$0.5 V_{CC2}$		V
Load impedance		AC coupling	5			k Ω
LPF frequency response		$f = 20\text{ kHz}$		-0.03		dB
		$f = 40\text{ kHz}$		-0.20		
Digital Filter Performance						
Pass band		$\pm 0.03\text{ dB}$			$0.454 f_S$	Hz
Stop band			$0.546 f_S$			Hz
Pass-band ripple					± 0.03	dB
Stop-band attenuation		$0.546 f_S$	-50			dB
Delay time				$20/f_S$		s
De-emphasis error				± 0.1		dB
POWER SUPPLY REQUIREMENTS						
V_{CC1} V_{CC2} V_{CC3}	Voltage range		4.25	5	5.5	VDC
V_{DD}			3	3.3	3.6	
$I_{CC}^{(9)}$	Supply current	$f_S = 48\text{ kHz}$		39	50	mA
		$f_S = 96\text{ kHz}$		41		
		Full power down ⁽¹⁰⁾		300		μA
I_{DD}		$f_S = 48\text{ kHz}$		10	15	mA
		$f_S = 96\text{ kHz}$		19		
		Full power down ⁽¹⁰⁾		90		μA
Power dissipation		Operation, $f_S = 48\text{ kHz}$		228	300	mW
		Operation, $f_S = 96\text{ kHz}$		268		
		ADC operation at $f_S = 48\text{ kHz}$ /DAC power down		180		
		ADC power down/DAC operation at $f_S = 48\text{ kHz}$		63		
		Full power down ⁽¹⁰⁾		1.8		

(8) $f_{OUT} = 1\text{ kHz}$, using System Two audio measurement system by Audio Precision in the RMS mode with 20-kHz LPF and 400-Hz HPF.

(9) $I_{CC} = I_{CC1} + I_{CC2} + I_{CC3}$

(10) Halt SCKI, BCK, LRCK.

ELECTRICAL CHARACTERISTICS (continued)

All specifications at $T_A = 25^\circ\text{C}$, $V_{CC1} = V_{CC2} = V_{CC3} = 5\text{ V}$, $V_{DD} = 3.3\text{ V}$, $f_S = 48\text{ kHz}$, $SCKI = 256 f_S$, 24-bit data, unless otherwise noted

PARAMETER	TEST CONDITIONS	MIN	TYP	MAX	UNIT
TEMPERATURE RANGE					
Operation temperature		-40		85	$^\circ\text{C}$
θ_{JA} Thermal resistance			100		$^\circ\text{C/W}$

DEVICE INFORMATION

BLOCK DIAGRAM

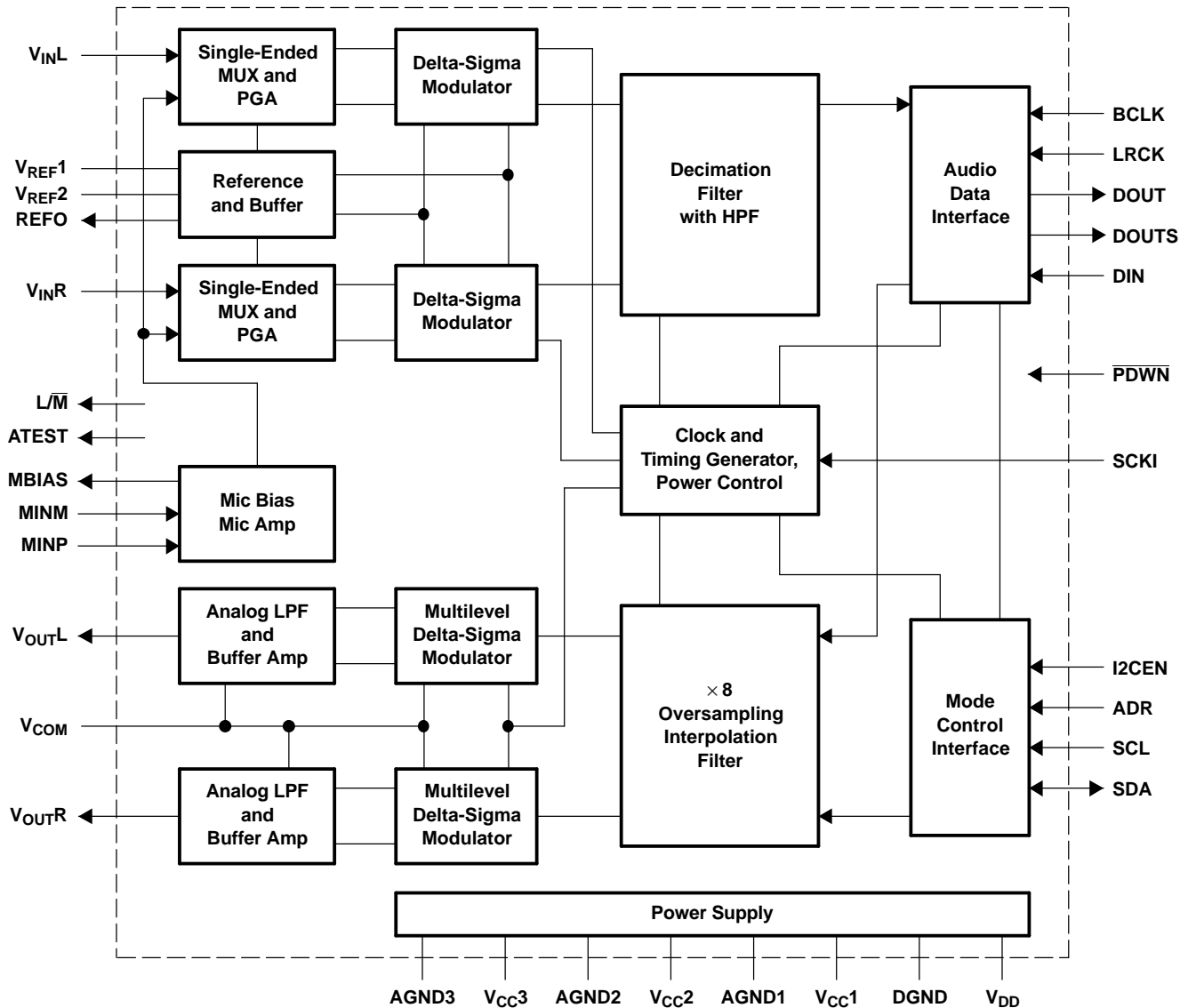

B0085-01

DEVICE INFORMATION (continued)

PIN ASSIGNMENTS

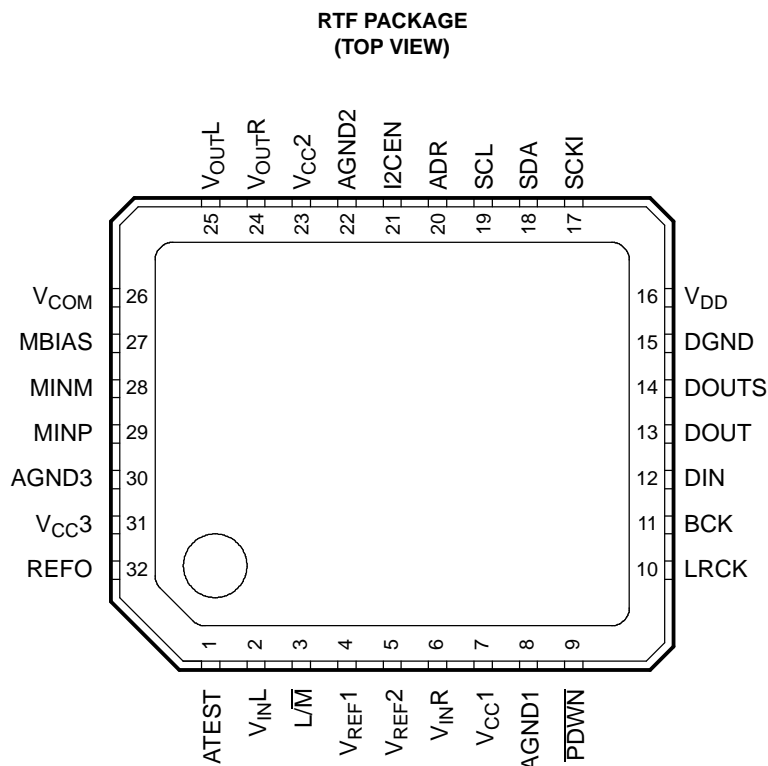

P0036-01

TERMINAL FUNCTIONS

TERMINAL NAME	NO.	I/O	DESCRIPTION
ADR	20	I	Mode control address select input ⁽¹⁾
AGND1	8		ADC analog ground
AGND2	22		DAC analog ground
AGND3	30		Microphone amplifier and bias analog ground
ATEST	1	O	Analog test, must be open
DGND	15		Digital ground
BCK	11	I	Audio data bit clock input ⁽²⁾
DIN	12	I	Audio data digital input ⁽³⁾
DOUT	13	O	Audio data digital output
DOUTS	14	O	S/PDIF data digital output
I2CEN	21	I	Mode control enable/disable input, active HIGH ⁽³⁾
L/M	3	O	ADC line/microphone select indicator
LRCK	10	I	Audio data latch enable input ⁽²⁾
MBIAS	27	O	Microphone bias output/decoupling, 0.75 V _{CC1}
MINM	28	I	Microphone amplifier input to ADC, inverting
MINP	29	I	Microphone amplifier input to ADC, non-inverting
PDWN	9	I	ADC and DAC power down control input, active LOW ⁽¹⁾
REFO	32	O	Reference output / decoupling, 0.5 V _{CC1}

(1) Schmitt-trigger input with 50-kΩ typical internal pull-down resistor, 5-V tolerant

(2) Schmitt-trigger input with 50-kΩ typical internal pull-down resistor

(3) Schmitt-trigger input, 5-V tolerant

DEVICE INFORMATION (continued)
TERMINAL FUNCTIONS (continued)

TERMINAL NAME	NO.	I/O	DESCRIPTION
SCKI	17	I	System clock input, 256 f_S ⁽³⁾
SCL	19	I	Mode control clock input ⁽³⁾
SDA	18	I/O	Mode control data input/output ⁽⁴⁾
V _{CC1}	7		ADC analog power supply, 5 V
V _{CC2}	23		DAC analog power supply, 5 V
V _{CC3}	31		Microphone amplifier and bias analog power supply, 5 V
V _{COM}	26		DAC common voltage decoupling, 0.5 V _{CC2}
V _{DD}	16		Digital power supply, 3.3 V
V _{INL}	2	I	Line input to ADC, L-channel
V _{INR}	6	I	Line input to ADC, R-channel
V _{OUTL}	25	O	Analog output from DAC, L-channel
V _{OUTR}	24	O	Analog output from DAC, R-channel
V _{REF1}	4		ADC reference 1 voltage output, 0.5 V _{CC1}
V _{REF2}	5		ADC reference 2 voltage decoupling, V _{CC1}

(4) Schmitt-trigger input/open-drain LOW output, 5-V tolerant

TYPICAL PERFORMANCE CURVES OF INTERNAL FILTER (ADC SECTION)

All specifications at $T_A = 25^\circ\text{C}$, $V_{CC1} = V_{CC2} = V_{CC3} = 5\text{ V}$, $V_{DD} = 3.3\text{ V}$, $f_S = 48\text{ kHz}$, SCKI = 256 f_S , 24-bit data, unless otherwise noted.

DIGITAL FILTER

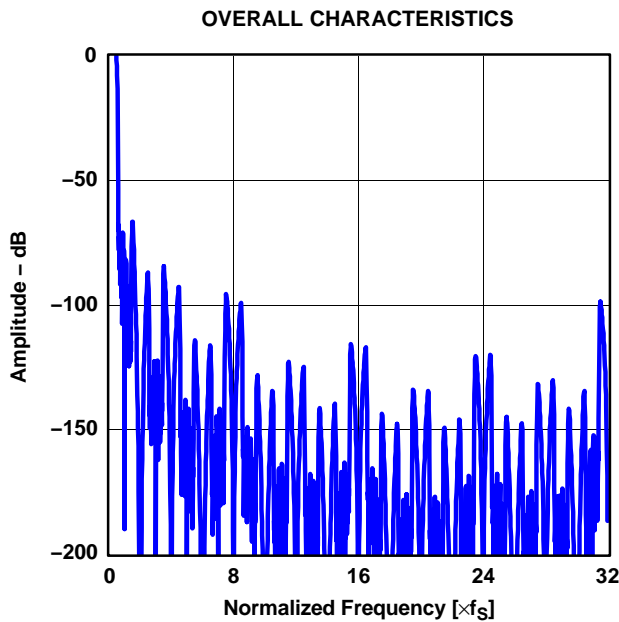

Figure 1.

G001

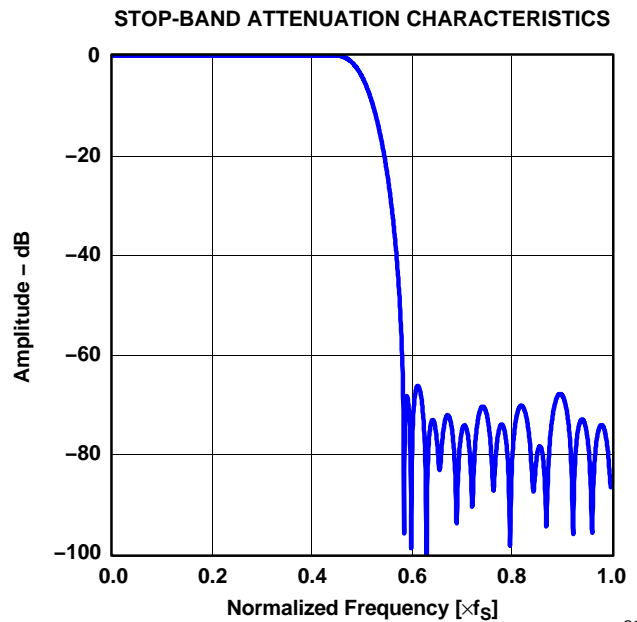

Figure 2.

G002

TYPICAL PERFORMANCE CURVES OF INTERNAL FILTER (ADC SECTION) (continued)

All specifications at $T_A = 25^\circ\text{C}$, $V_{CC1} = V_{CC2} = V_{CC3} = 5\text{ V}$, $V_{DD} = 3.3\text{ V}$, $f_s = 48\text{ kHz}$, $\text{SCKI} = 256f_s$, 24-bit data, unless otherwise noted.

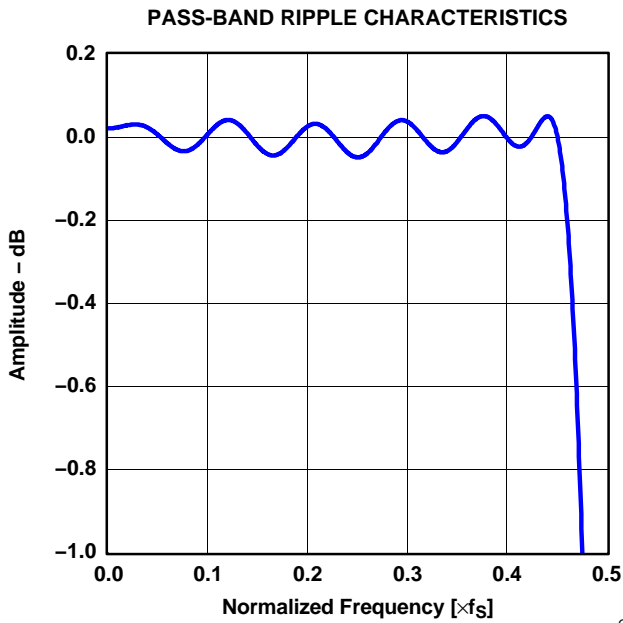

Figure 3.

G003

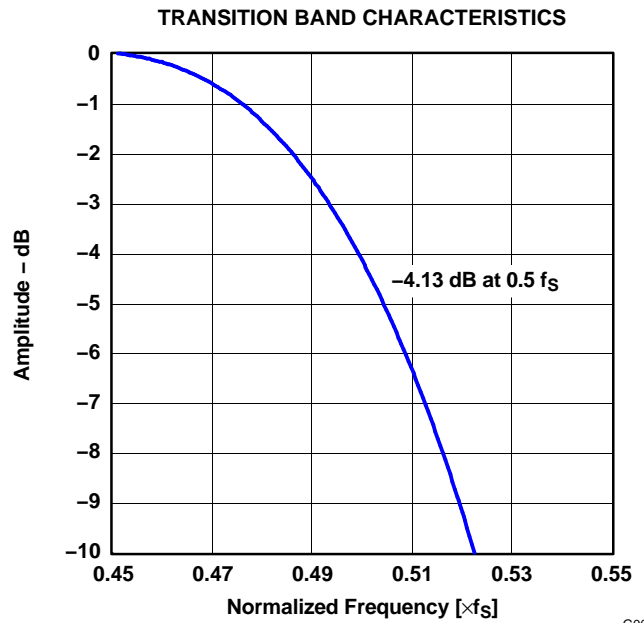

Figure 4.

G004

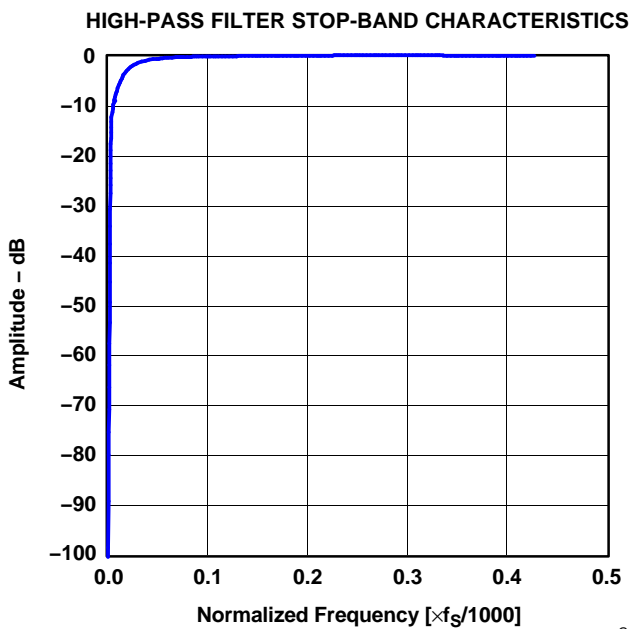

Figure 5.

G005

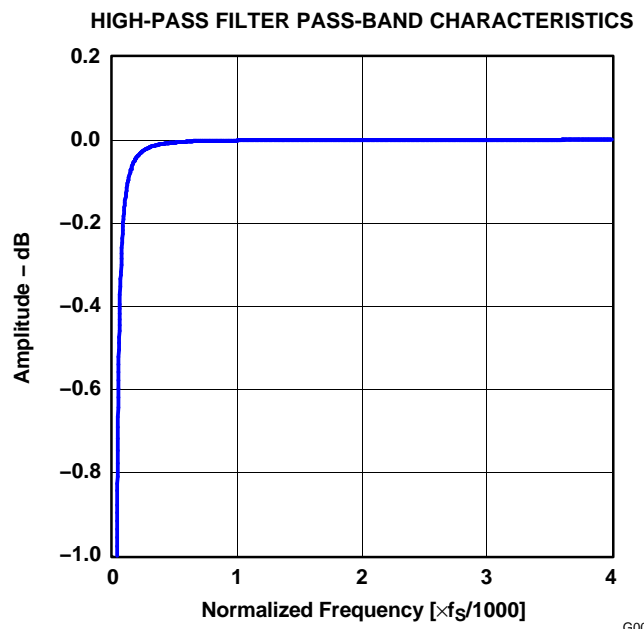

Figure 6.

G006

TYPICAL PERFORMANCE CURVES OF INTERNAL FILTER (ADC SECTION) (continued)

All specifications at $T_A = 25^\circ\text{C}$, $V_{CC1} = V_{CC2} = V_{CC3} = 5\text{ V}$, $V_{DD} = 3.3\text{ V}$, $f_S = 48\text{ kHz}$, $\text{SCKI} = 256f_S$, 24-bit data, unless otherwise noted.

ANALOG FILTER (Line Input, PGA Gain = 0 dB)

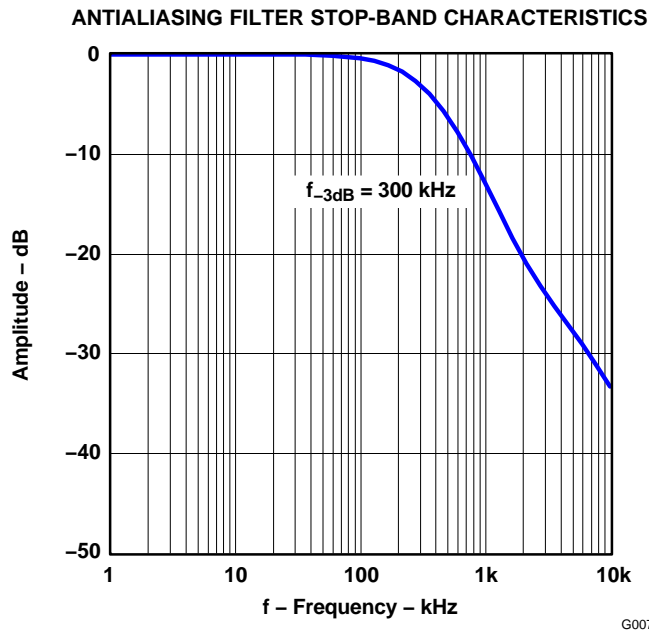

Figure 7.

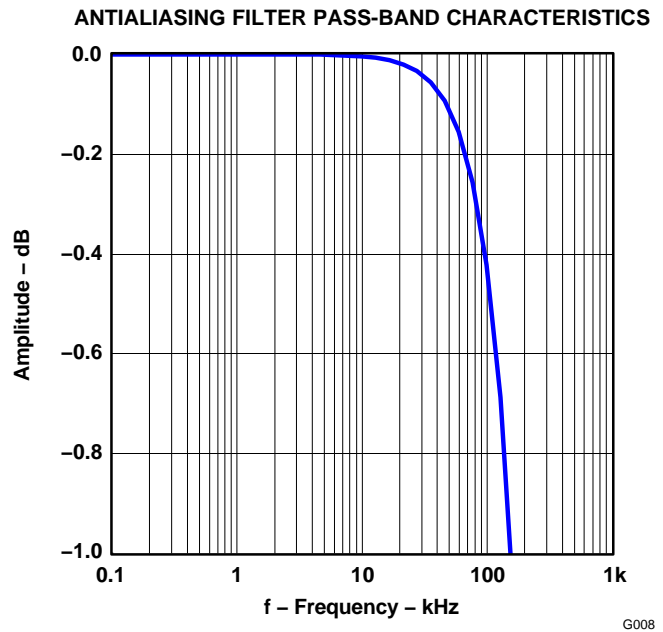

Figure 8.

TYPICAL PERFORMANCE CURVES OF INTERNAL FILTER (DAC SECTION)

All specifications at $T_A = 25^\circ\text{C}$, $V_{CC1} = V_{CC2} = V_{CC3} = 5\text{ V}$, $V_{DD} = 3.3\text{ V}$, $f_S = 48\text{ kHz}$, $\text{SCKI} = 256f_S$, 24-bit data, unless otherwise noted.

DIGITAL FILTER

FREQUENCY RESPONSE, STOP BAND (Sharp Roll-off)

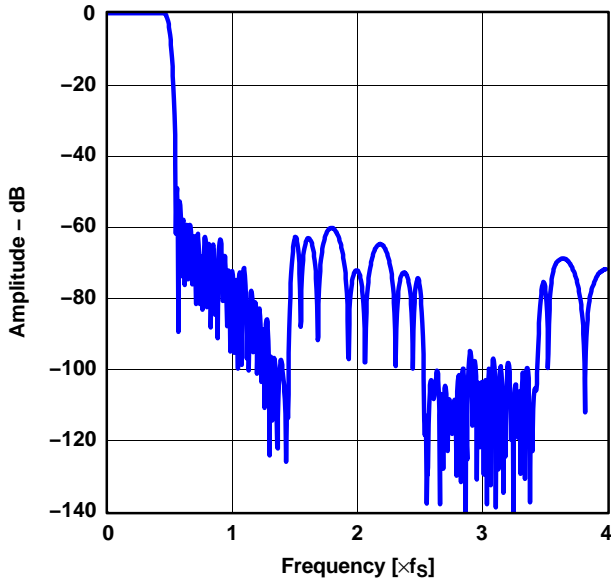

G009

Figure 9.

FREQUENCY RESPONSE, PASS BAND (Sharp Roll-off)

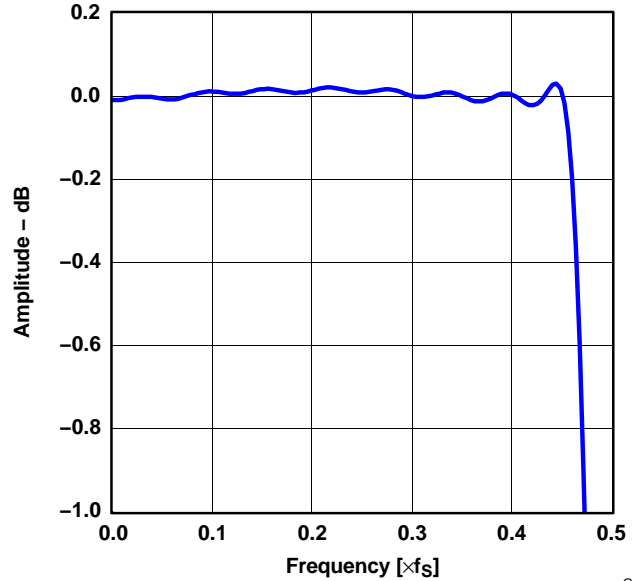

G010

Figure 10.

DE-EMPHASIS ($f_S = 32\text{ kHz}$)

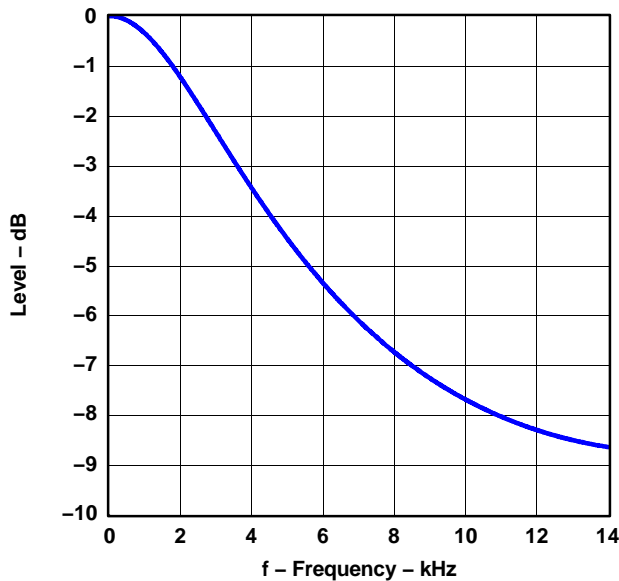

G011

Figure 11.

DE-EMPHASIS ERROR ($f_S = 32\text{ kHz}$)

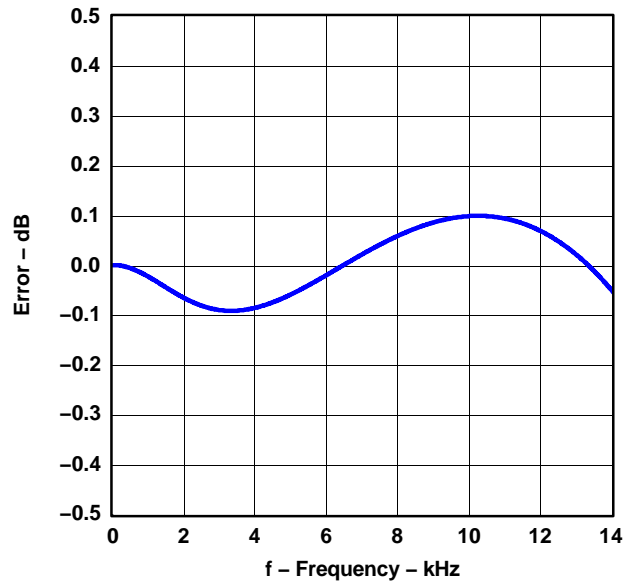

G012

Figure 12.

TYPICAL PERFORMANCE CURVES OF INTERNAL FILTER (DAC SECTION) (continued)

All specifications at $T_A = 25^\circ\text{C}$, $V_{CC1} = V_{CC2} = V_{CC3} = 5\text{ V}$, $V_{DD} = 3.3\text{ V}$, $f_S = 48\text{ kHz}$, $\text{SCKI} = 256f_S$, 24-bit data, unless otherwise noted.

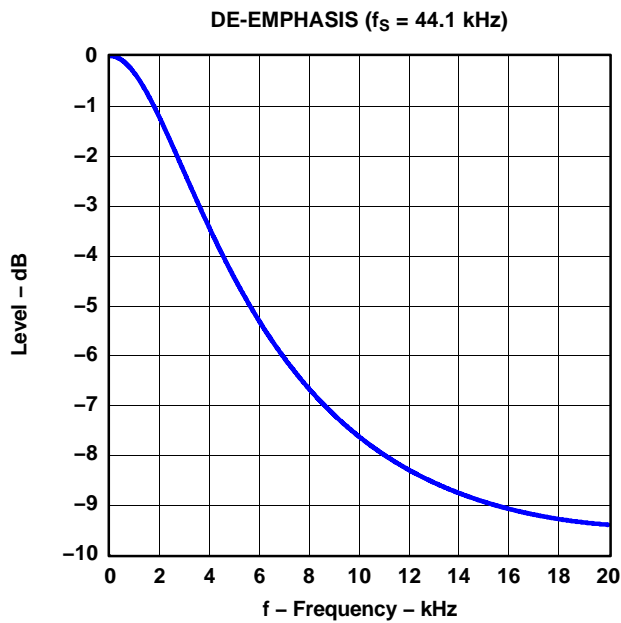

Figure 13.

G013

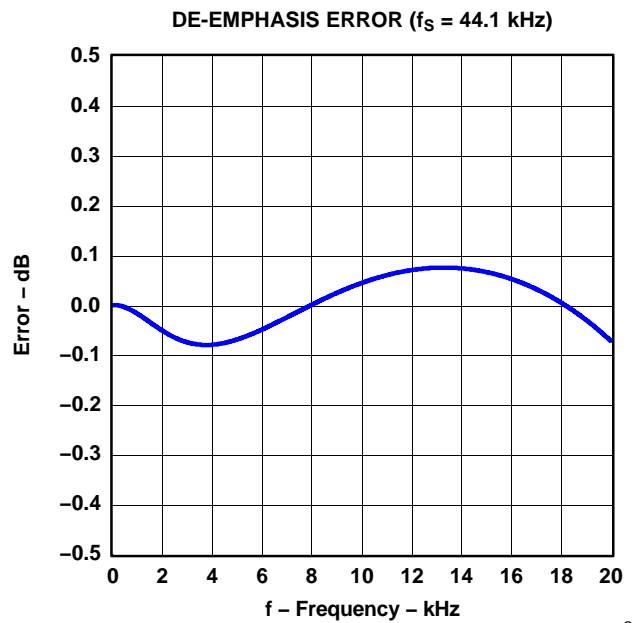

Figure 14.

G014

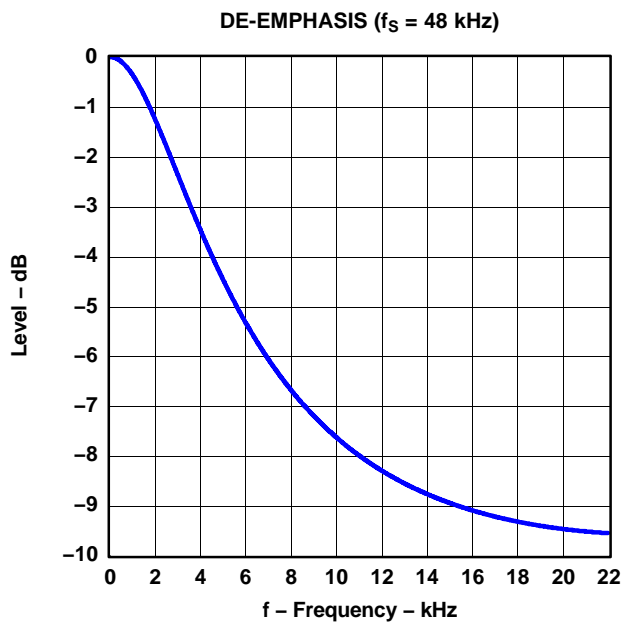

Figure 15.

G015

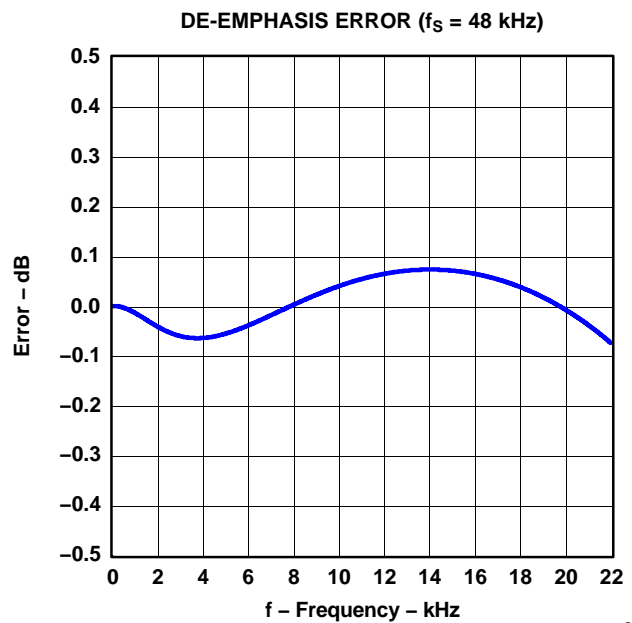

Figure 16.

G016

TYPICAL PERFORMANCE CURVES OF INTERNAL FILTER (DAC SECTION) (continued)

All specifications at $T_A = 25^\circ\text{C}$, $V_{CC1} = V_{CC2} = V_{CC3} = 5\text{ V}$, $V_{DD} = 3.3\text{ V}$, $f_s = 48\text{ kHz}$, $\text{SCKI} = 256f_s$, 24-bit data, unless otherwise noted.

ANALOG FILTER

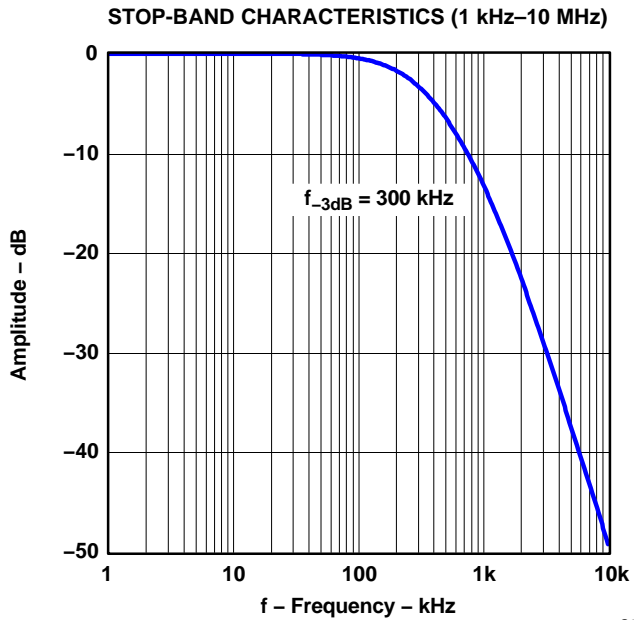

Figure 17.

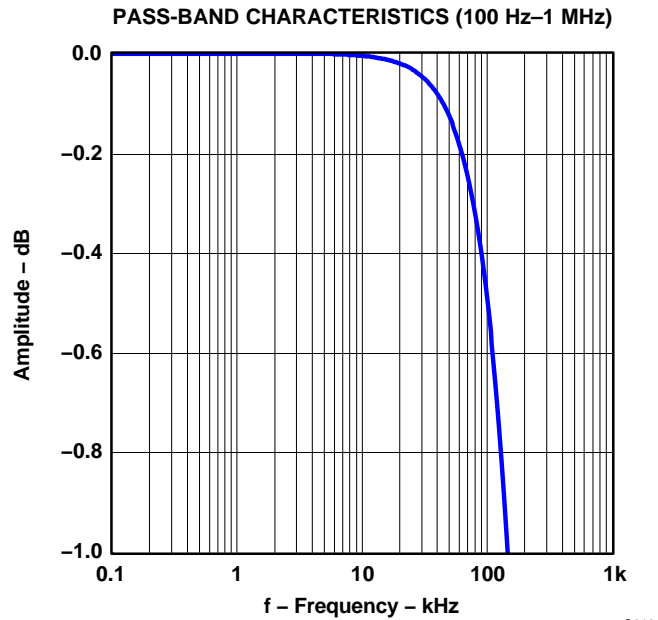

Figure 18.

TYPICAL PERFORMANCE CURVES (ADC SECTION)

All specifications at $T_A = 25^\circ\text{C}$, $V_{CC1} = V_{CC2} = V_{CC3} = 5\text{ V}$, $V_{DD} = 3.3\text{ V}$, $f_S = 48\text{ kHz}$, $\text{SCKI} = 256\text{ f}_S$, 24-bit data, unless otherwise noted.

LINE INPUT (at PGA Gain = 0 dB)

**THD+N
vs
TEMPERATURE**

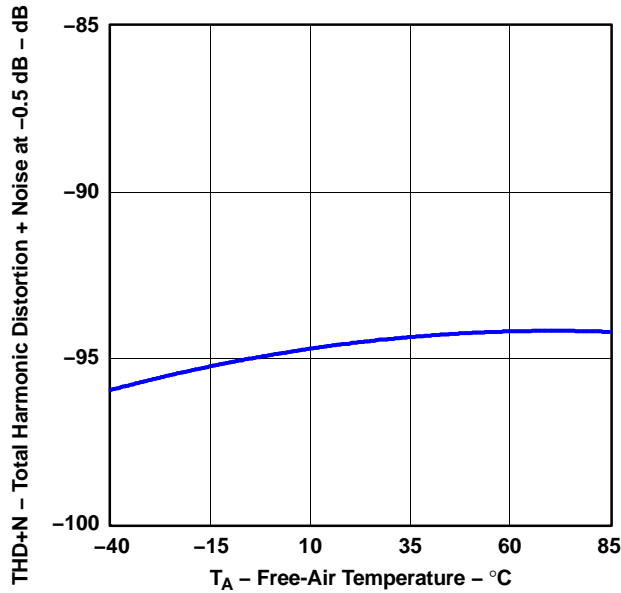

G019

Figure 19.

**DYNAMIC RANGE AND SNR
vs
TEMPERATURE**

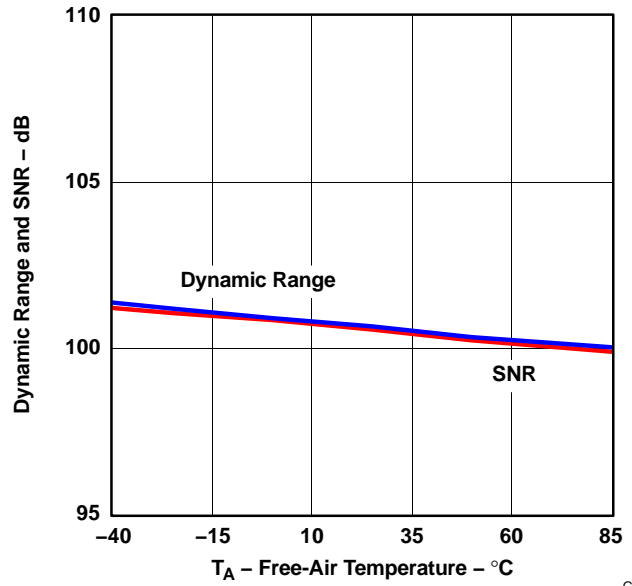

G020

Figure 20.

**THD+N
vs
SUPPLY VOLTAGE**

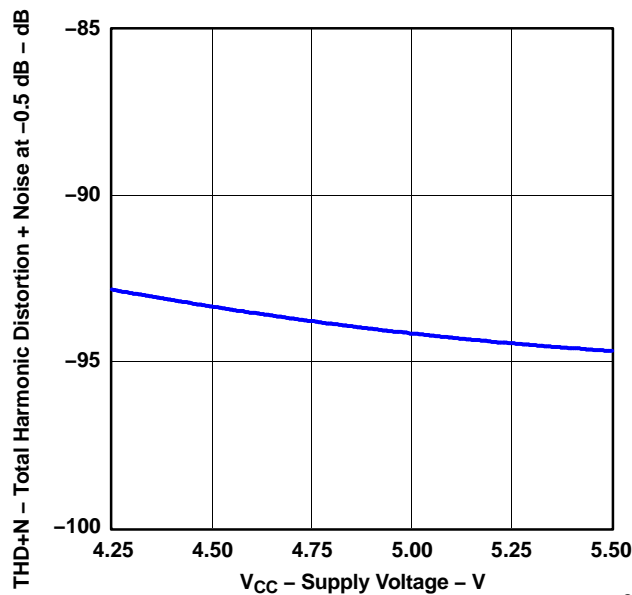

G021

Figure 21.

**DYNAMIC RANGE AND SNR
vs
SUPPLY VOLTAGE**

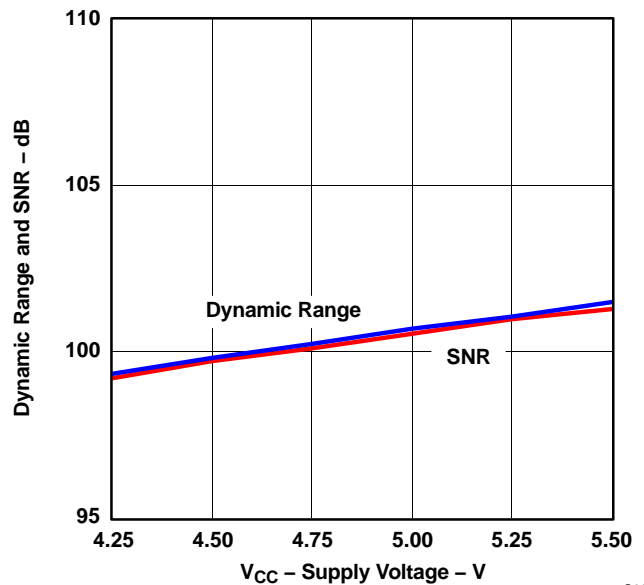

G022

Figure 22.

TYPICAL PERFORMANCE CURVES (ADC SECTION) (continued)

All specifications at $T_A = 25^\circ\text{C}$, $V_{CC1} = V_{CC2} = V_{CC3} = 5\text{ V}$, $V_{DD} = 3.3\text{ V}$, $f_S = 48\text{ kHz}$, $\text{SCKI} = 256 f_S$, 24-bit data, unless otherwise noted.

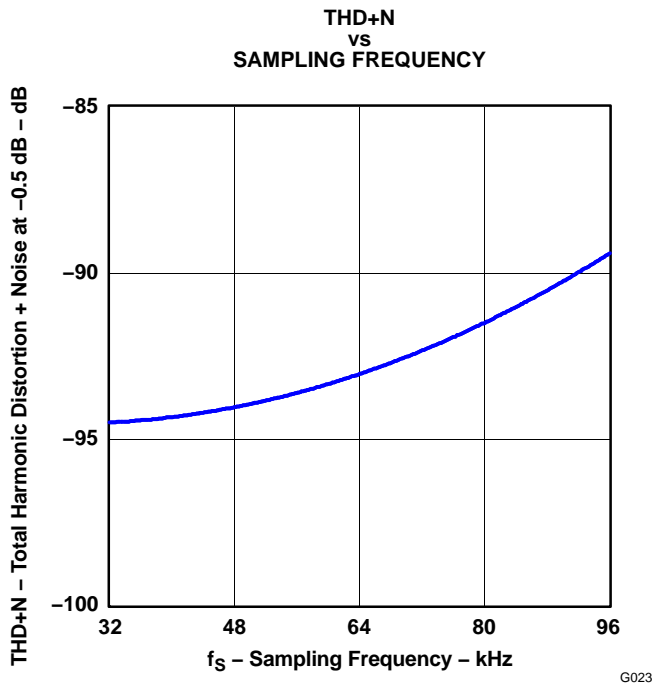

Figure 23.

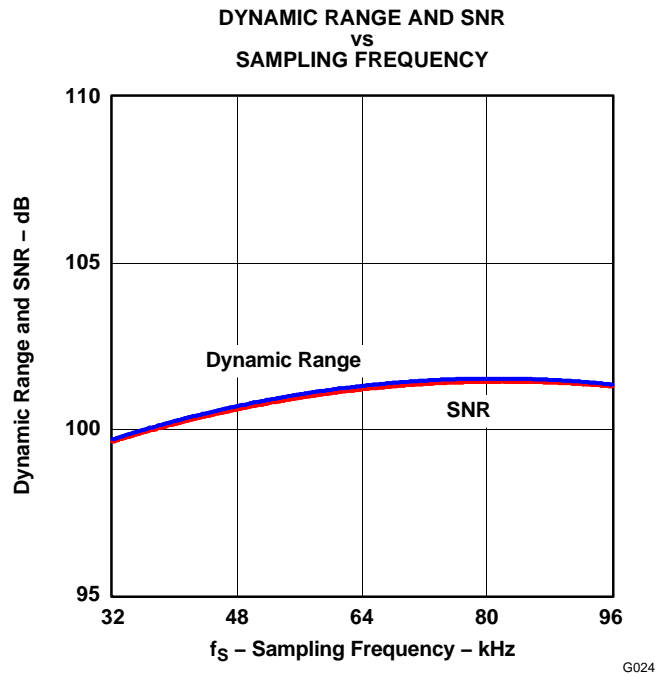

Figure 24.

TYPICAL PERFORMANCE CURVES (DAC SECTION)

All specifications at $T_A = 25^\circ\text{C}$, $V_{CC1} = V_{CC2} = V_{CC3} = 5\text{ V}$, $V_{DD} = 3.3\text{ V}$, $f_s = 48\text{ kHz}$, $\text{SCKI} = 256\text{ f}_s$, 24-bit data, unless otherwise noted.

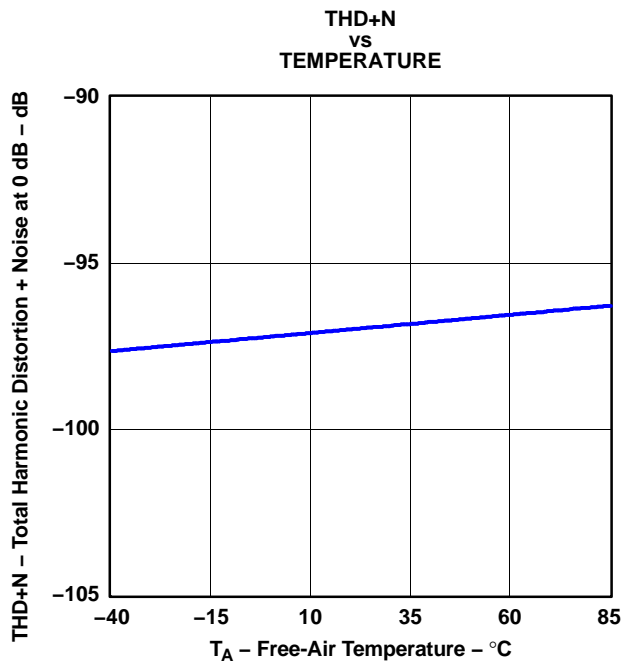

Figure 25.

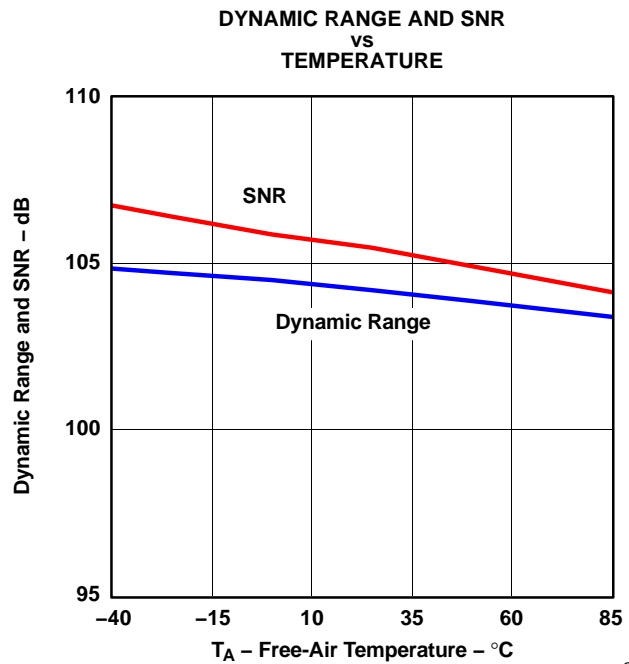

Figure 26.

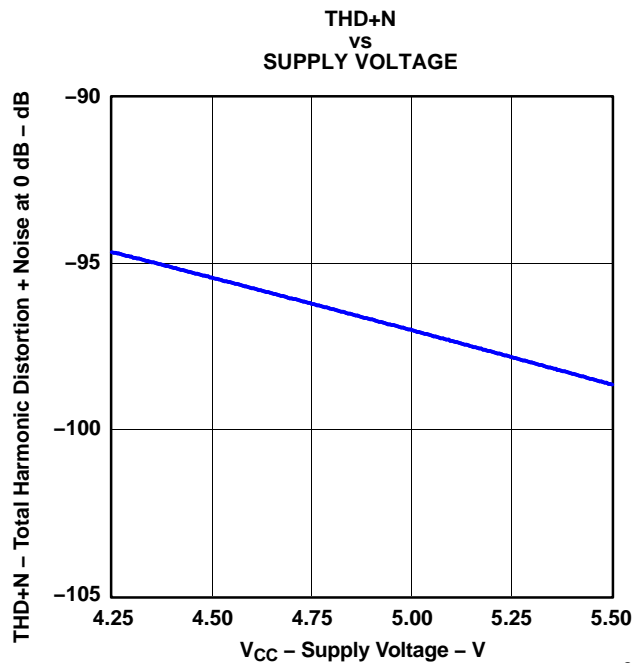

Figure 27.

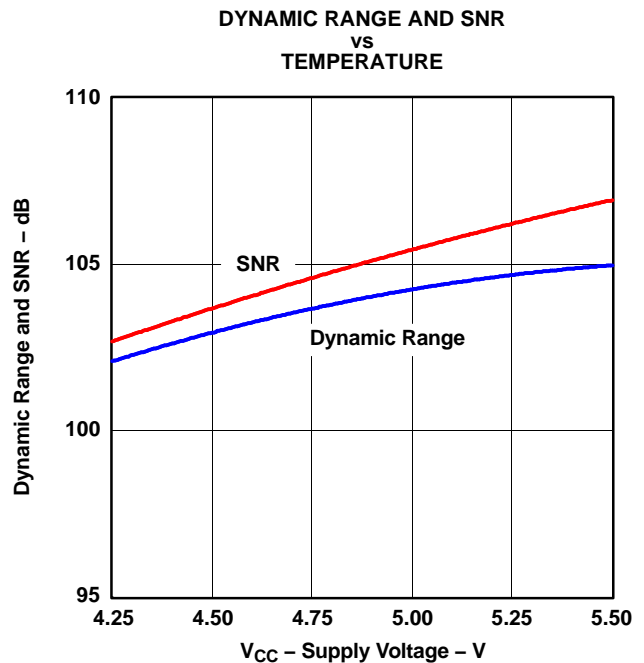

Figure 28.

TYPICAL PERFORMANCE CURVES (DAC SECTION) (continued)

All specifications at $T_A = 25^\circ\text{C}$, $V_{CC1} = V_{CC2} = V_{CC3} = 5\text{ V}$, $V_{DD} = 3.3\text{ V}$, $f_S = 48\text{ kHz}$, $\text{SCKI} = 256 f_S$, 24-bit data, unless otherwise noted.

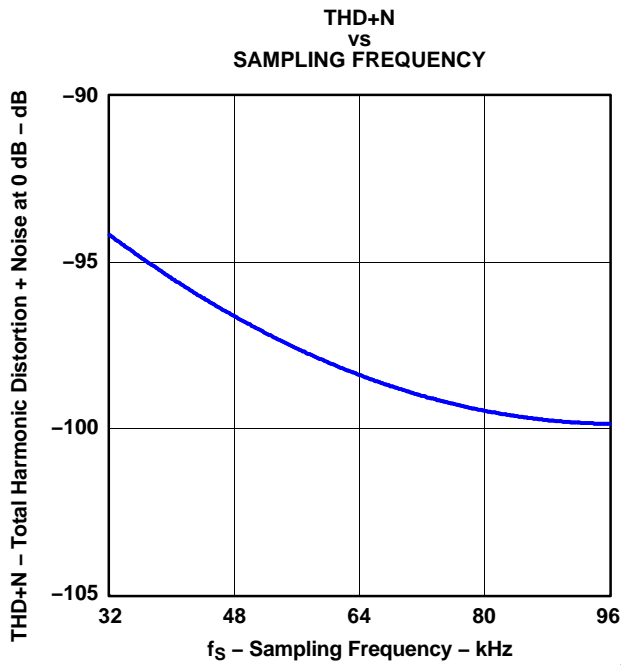

Figure 29.

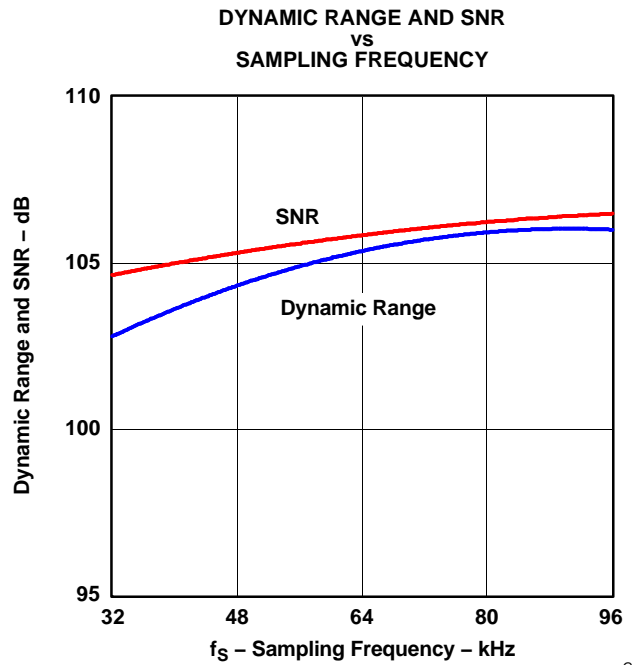

Figure 30.

TYPICAL PERFORMANCE CURVES

All specifications at $T_A = 25^\circ\text{C}$, $V_{CC1} = V_{CC2} = V_{CC3} = 5\text{ V}$, $V_{DD} = 3.3\text{ V}$, $f_S = 48\text{ kHz}$, $\text{SCKI} = 256 f_S$, 24-bit data, unless otherwise noted.

ADC OUTPUT SPECTRUM (Line Input, at PGA Gain = 0 dB)

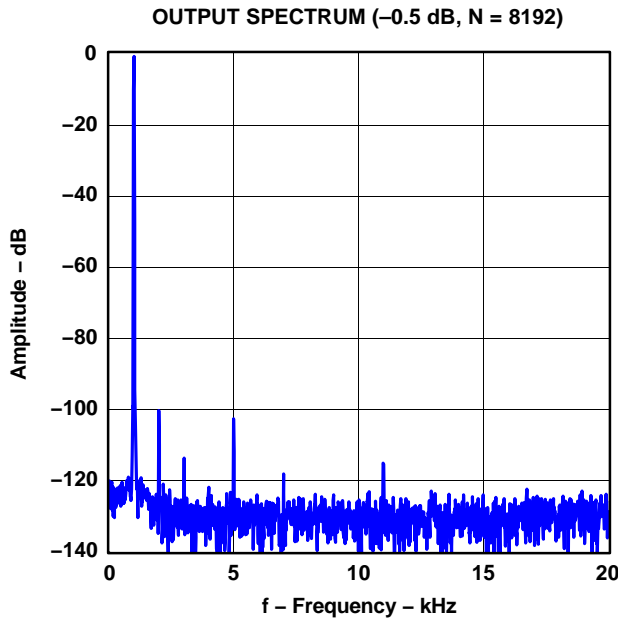

Figure 31.

G031

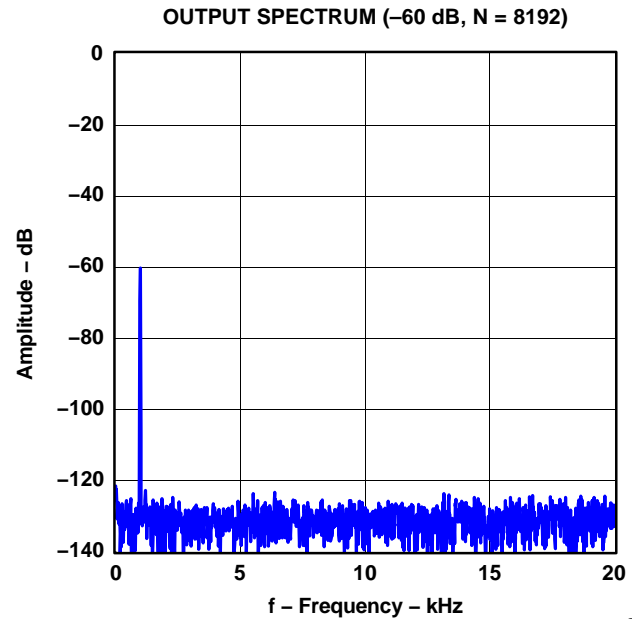

Figure 32.

G032

DAC OUTPUT SPECTRUM

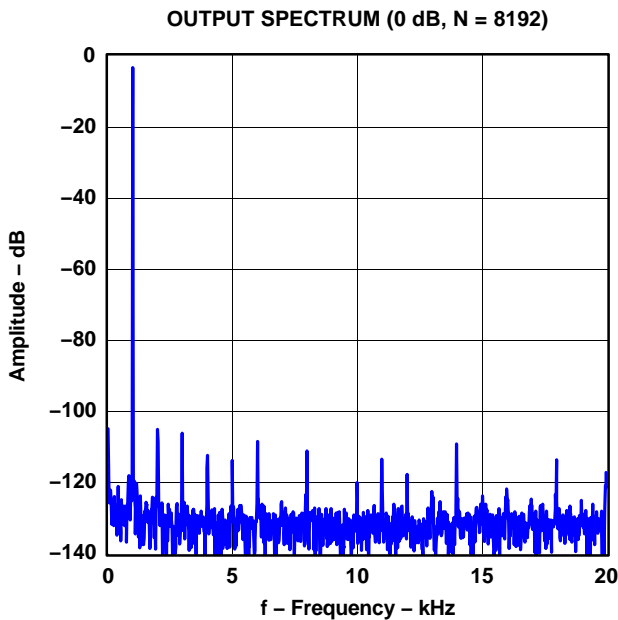

Figure 33.

G033

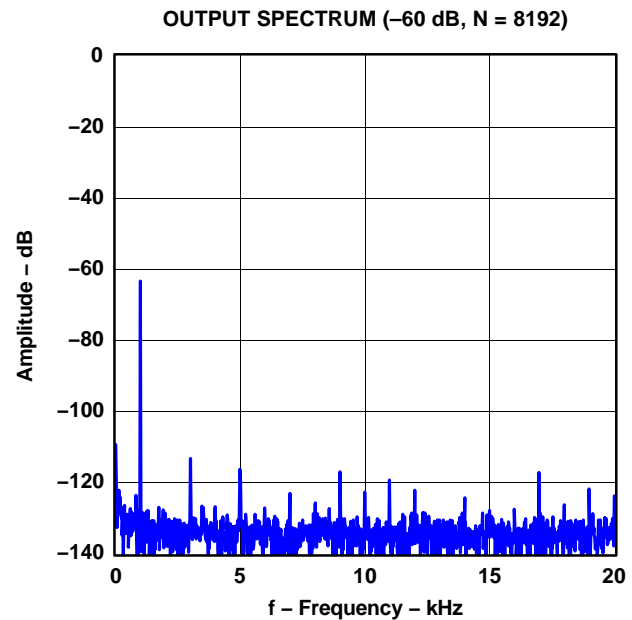

Figure 34.

G034

TYPICAL PERFORMANCE CURVES (continued)

All specifications at $T_A = 25^\circ\text{C}$, $V_{CC1} = V_{CC2} = V_{CC3} = 5\text{ V}$, $V_{DD} = 3.3\text{ V}$, $f_s = 48\text{ kHz}$, $\text{SCKI} = 256 f_s$, 24-bit data, unless otherwise noted.

SUPPLY CURRENT

SUPPLY CURRENT vs TEMPERATURE

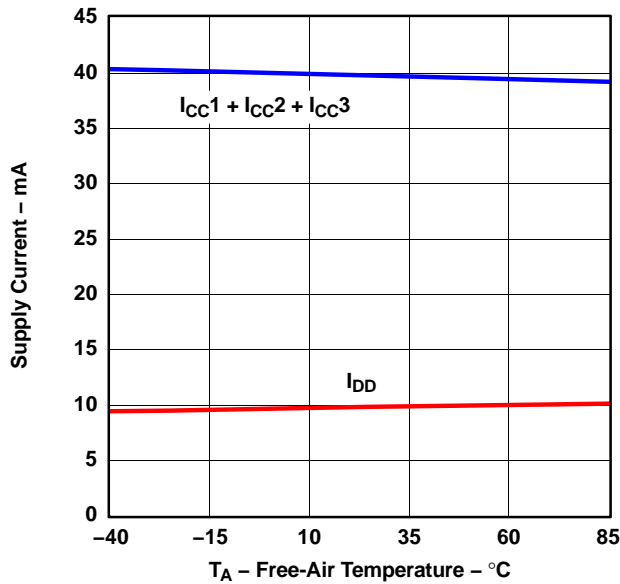

Figure 35.

SUPPLY CURRENT vs SAMPLING FREQUENCY, ADC AND DAC OPERATING

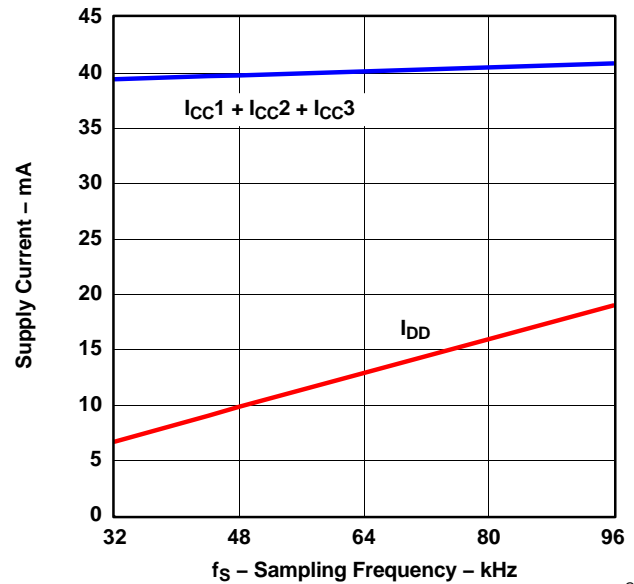

Figure 36.

SUPPLY CURRENT vs SUPPLY VOLTAGE

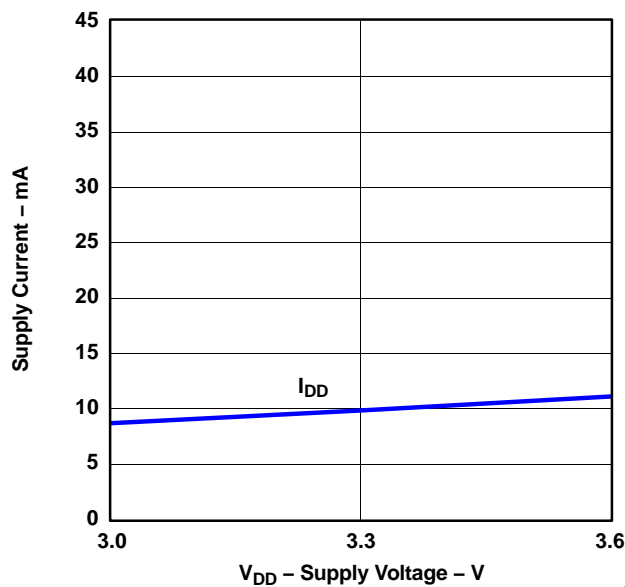

Figure 37.

SUPPLY CURRENT vs SUPPLY VOLTAGE

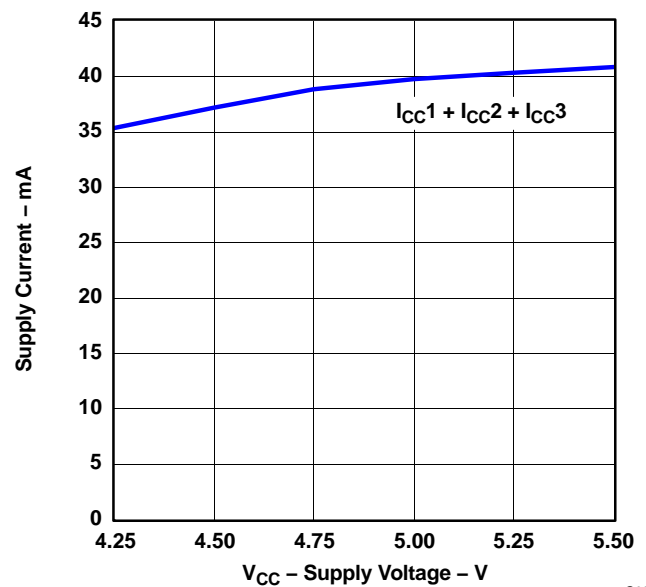

Figure 38.

THEORY OF OPERATION

ADC SECTION

The ADC block consists of a reference circuit, two channels of single-ended to differential converter, a fifth-order delta-sigma modulator with fully differential architecture, a decimation filter with high-pass filter, and a serial interface circuit which is also used as the serial interface for the DAC input signal as shown in the block diagram.

Figure 39 is the block diagram of the fifth-order delta-sigma modulator and transfer function.

An on-chip reference circuit with two external capacitors provides all reference voltages that are needed in the ADC section, and defines the full-scale voltage range of both channels.

An on-chip, single-ended to differential signal converter saves the design, space, and extra parts cost of an external signal converter.

Full differential architecture provides a wide dynamic range and excellent power supply rejection performance.

The input signal is sampled at $\times 64$ oversampling rate and an on-chip antialiasing filter eliminates the need for an external sample-hold amplifier. A fifth-order delta-sigma noise shaper, which consists of five integrators using the switched-capacitor technique and a comparator, shapes the quantization noise generated outside of audio signal band by the comparator and 1-bit DAC.

The high-order delta-sigma modulation randomizes the modulator outputs and reduces idle-tone level.

The $64 f_s$, 1-bit stream from the delta-sigma modulator is converted to a $1-f_s$, 24-bit digital signal by removing high-frequency noise components with the decimation filter.

The dc component of the signal is removed by the HPF, and the HPF output is converted to a time-multiplexed serial signal through the serial interface.

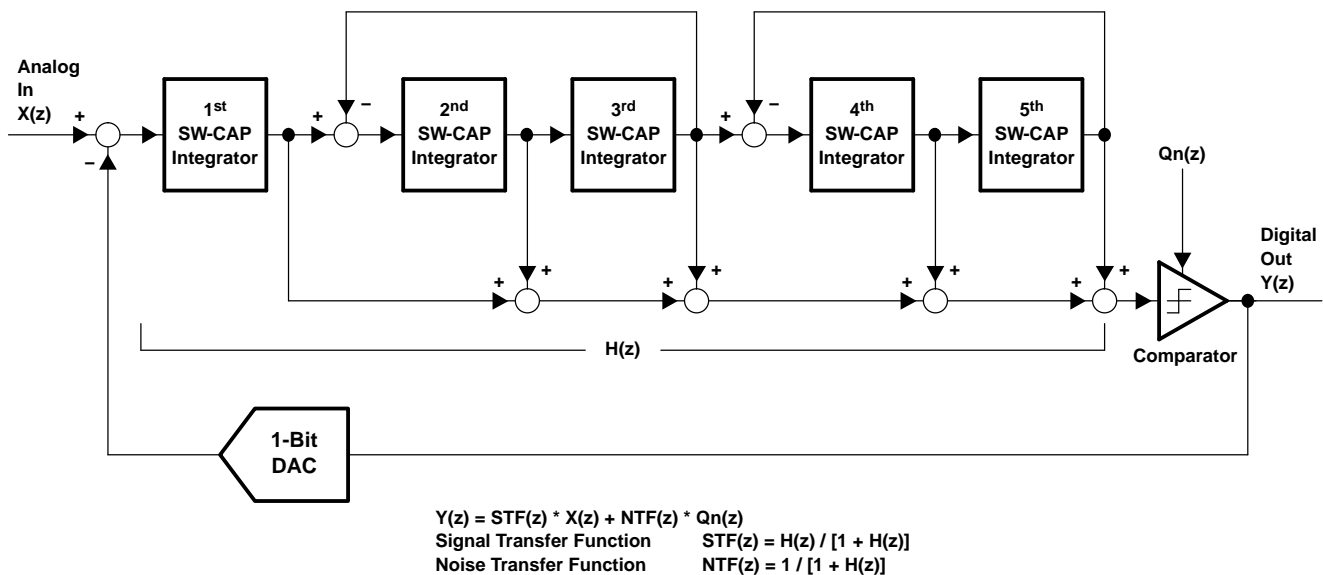

B0005-02

Figure 39. Block Diagram of Fifth-Order Delta-Sigma Modulator

DAC SECTION

The DAC section is based on the delta-sigma modulator, which consists of an 8-level amplitude quantizer and a fourth-order noise shaper. This section converts the oversampled input data to 8-level delta-sigma format. A block diagram of the 8-level delta-sigma modulator is shown in Figure 40. This 8-level delta-sigma modulator has the advantage of stability and clock jitter over the typical one-bit (2-level) delta-sigma modulator. The combined oversampling rate of the delta-sigma modulator and the internal $8\times$ interpolation filter is $64 f_s$ for all system clocks. The theoretical quantization-noise performance of the 8-level delta-sigma modulator is shown in Figure 41.

THEORY OF OPERATION (continued)

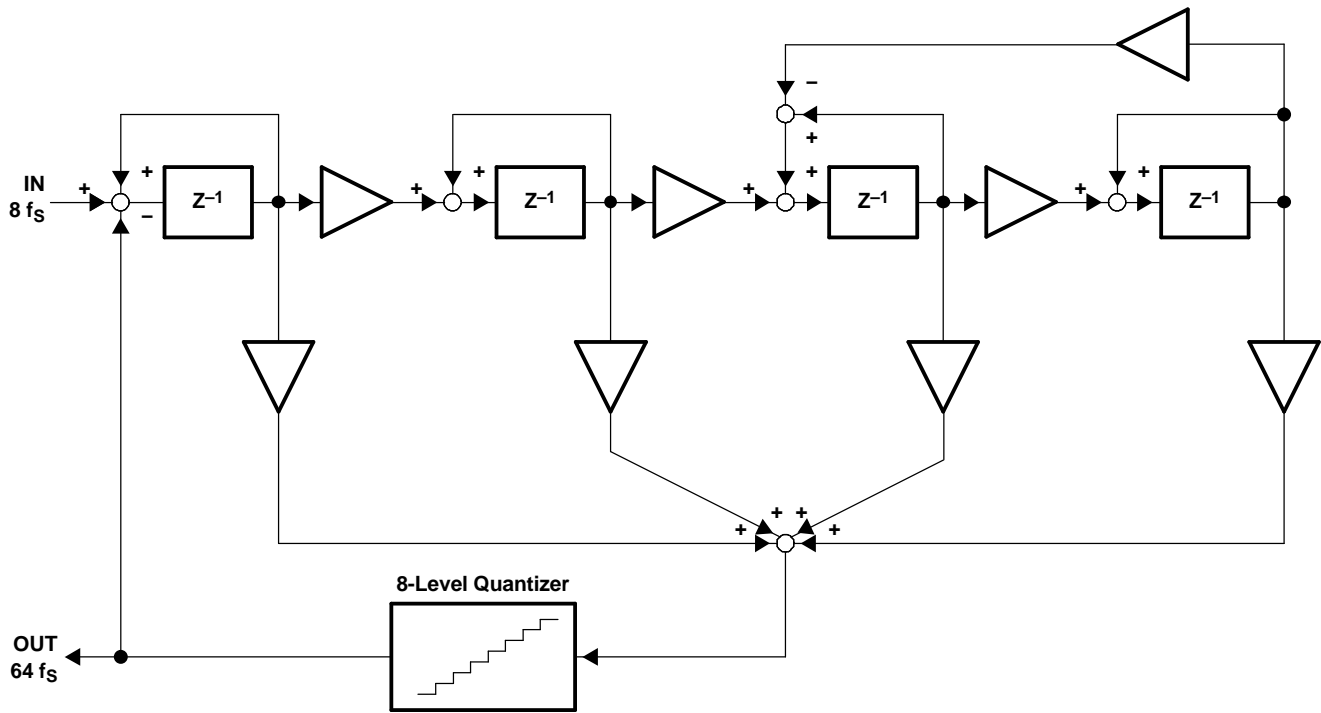

B0008-03

Figure 40. 8-Level Delta-Sigma Modulator Block Diagram

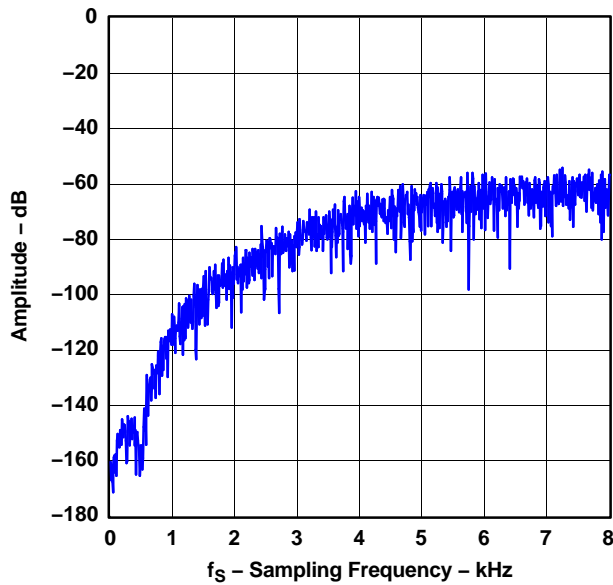

G039

Figure 41. Quantization Noise Spectrum

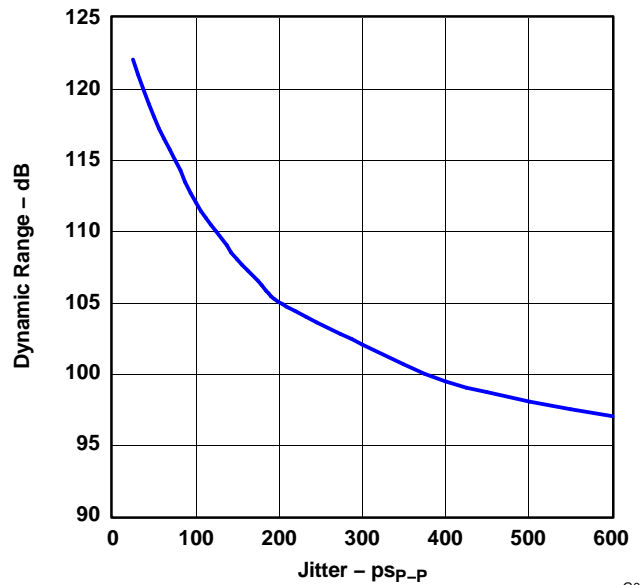

G040

Figure 42. Clock Jitter

THEORY OF OPERATION (continued)

SYSTEM CLOCK

The system clock for the PCM3052A must be $256 f_s$, where f_s is the audio sampling rate, 16 kHz to 96 kHz. Table 1 lists typical system clock frequencies, and Figure 43 illustrates the system clock timing.

Table 1. Typical System Clock

SAMPLING RATE FREQUENCY (f_s) – LRCK	SYSTEM CLOCK FREQUENCY – MHz	
	$256 f_s$	
16 kHz	4.096	
32 kHz	8.192	
44.1 kHz	11.2896	
48 kHz	12.288	
96 kHz	24.576	

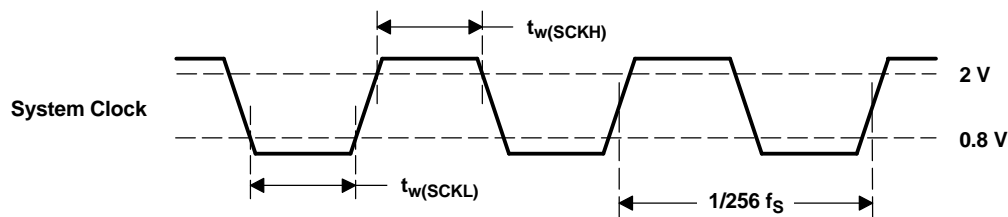

T0005–10

PARAMETER		MIN	MAX	UNIT
$t_w(\text{SCKH})$	System clock pulse duration, HIGH	16		ns
$t_w(\text{SCKL})$	System clock pulse duration, LOW	16		ns

Figure 43. System Clock Timing

POWER SUPPLY ON, EXTERNAL RESET, AND POWER DOWN

The PCM3052A has both an internal power-on-reset circuit and an external reset circuit. The sequences for both resets are shown as follows.

Figure 44 is the timing chart of the internal power-on reset. Two power-on-reset circuits are implemented, one each for V_{CC1} and V_{DD} . Initialization (reset) is performed automatically at the time when V_{CC1} and V_{DD} exceed 3.9 V (typical) and 2.2 V (typical), respectively.

Internal reset is released after 1024 SCKI from power-on-reset release, and the PCM3052A begins normal operation. V_{OUTL} and V_{OUTR} from the DAC are forced to the V_{COM} ($= 0.5 V_{CC2}$) level as V_{CC2} rises. When synchronization between SCKI, BCK, and LRCK is maintained, V_{OUTL} and V_{OUTR} go into the fade-in sequence. Then V_{OUTL} and V_{OUTR} provide outputs corresponding to DIN after $t_{(DACDLY1)} = 2100/f_s$ from power-on-reset release. On the other hand, DOUT from the ADC provides an output corresponding to V_{INL} and V_{INR} after $t_{(ADC DLY1)} = 4500/f_s$ from power-on-reset release. If synchronization is not maintained, the internal reset is not released, and operation is kept in the power-down mode. After resynchronization, the DAC goes into the fade-in sequence, and the ADC goes into normal operation after internal initialization.

DOUTS can provide S/PDIF data after the power-on-reset release if the SPDIF bit is HIGH (see serial control port for mode control section).

Figure 45 shows timing chart for external reset. The $\overline{\text{PDWN}}$ pin (pin 9) initiates external forced reset when $\overline{\text{PDWN}} = \text{LOW}$, and it provides the power-down mode, which is the lowest power-dissipation state in the PCM3052A.

When $\overline{\text{PDWN}}$ transitions from HIGH to LOW while SCKI, BCK, and LRCK are synchronized, V_{OUTL} and V_{OUTR} are faded out and forced into V_{COM} ($= 0.5 V_{CC2}$) level after $t_{(DACDLY1)} = 2100/f_s$. At the same time as the internal reset becomes LOW, DOUT becomes ZERO, the PCM3052A enters the power-down mode. To return to normal operation, set $\overline{\text{PDWN}}$ to HIGH. Then the power-on reset sequence, Figure 44, is performed.

DOUTS is driven LOW immediately after $\overline{\text{PDWN}}$ is asserted and recovers about $40/f_s$ following $\overline{\text{PDWN}}$ release.

Notes:

1. Large pop noises can be generated on V_{OUTL} and V_{OUTR} if the power supply is turned off during normal operation.
2. To switch $\overline{\text{PDWN}}$ during fade-in or fade-out causes an immediate change between fade-in and fade-out.
3. Changing mode controls during normal operation can degrade analog performance. It is recommended that mode controls be changed through the serial control port, and that changing or stopping the clock, switching the power supply off, etc., be done in the power-down mode.

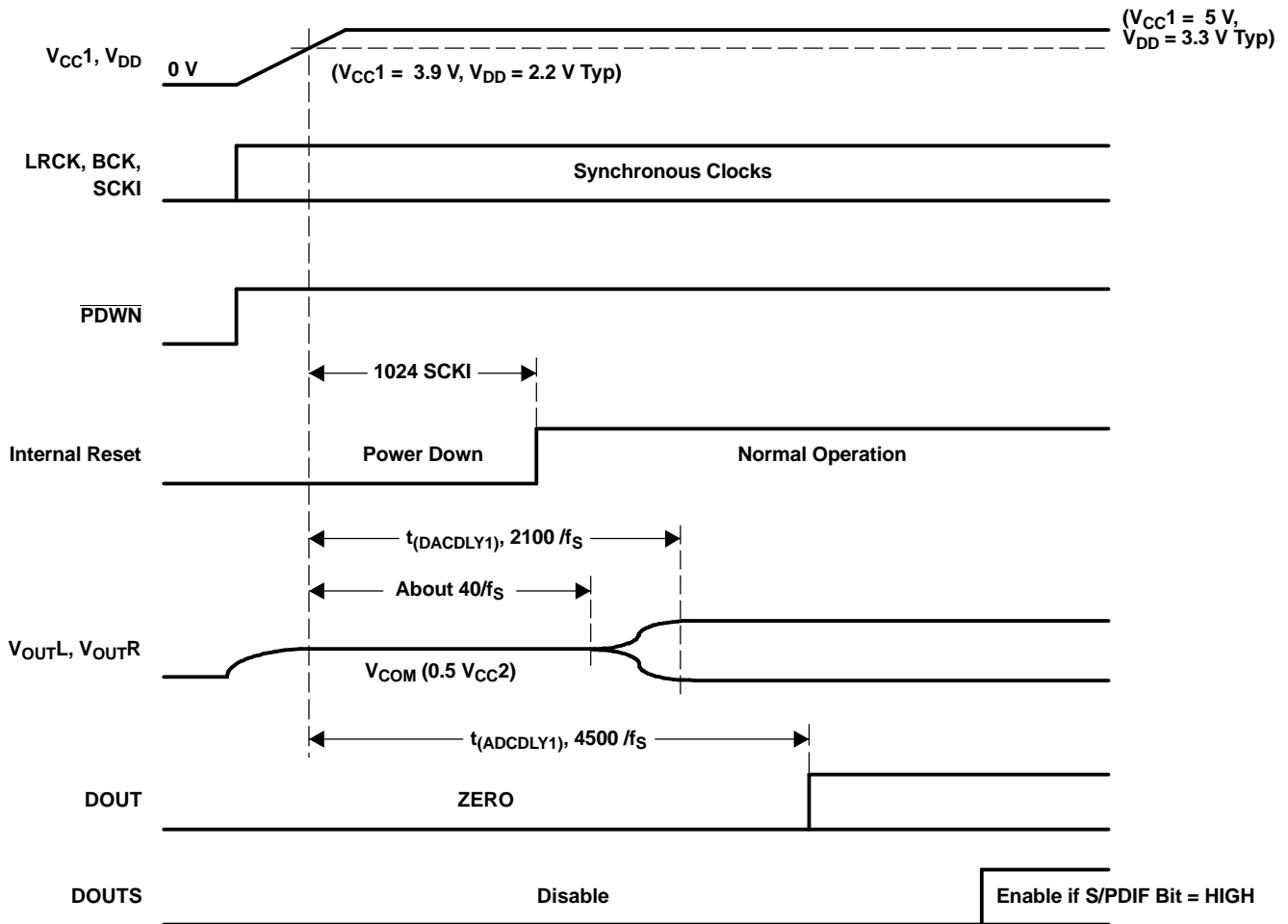

T0097-01

Figure 44. DAC Output and ADC Output for Power-On Reset

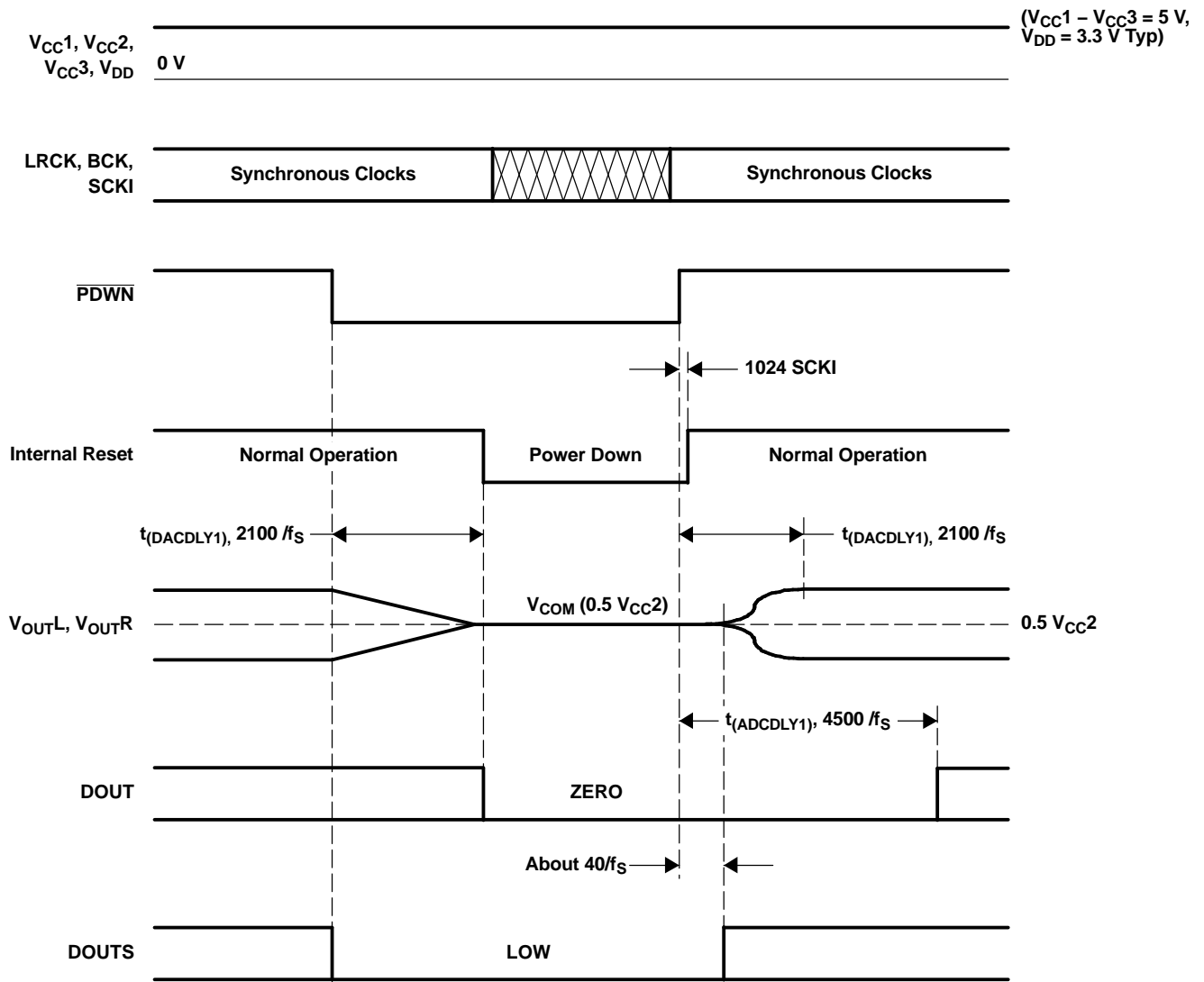

T0098-01

Figure 45. DAC Output and ADC Output for External Reset (\overline{PDWN} Pin)

PCM AUDIO INTERFACE

Digital audio data is interfaced to the PCM3052A on LRCK (pin 10), BCK (pin 11), DIN (pin 12), DOUT (pin 13), and DOUTS (pin 14). The PCM3052A can accept 24-bit I²S format only. In case of AC-3 type output data for DOUTS, bits 17 to 24 of DIN must be held LOW. See the *Digital Audio Interface Transmitter (DIT)* section of this data sheet.

Table 2. Audio Data Format

DATA FORMAT
24-bit, MSB-first, I ² S

The PCM3052A accepts only 64 clocks of BCK during one clock of LRCK. [Figure 46](#) and [Figure 47](#) illustrate audio data input/output format and timing.

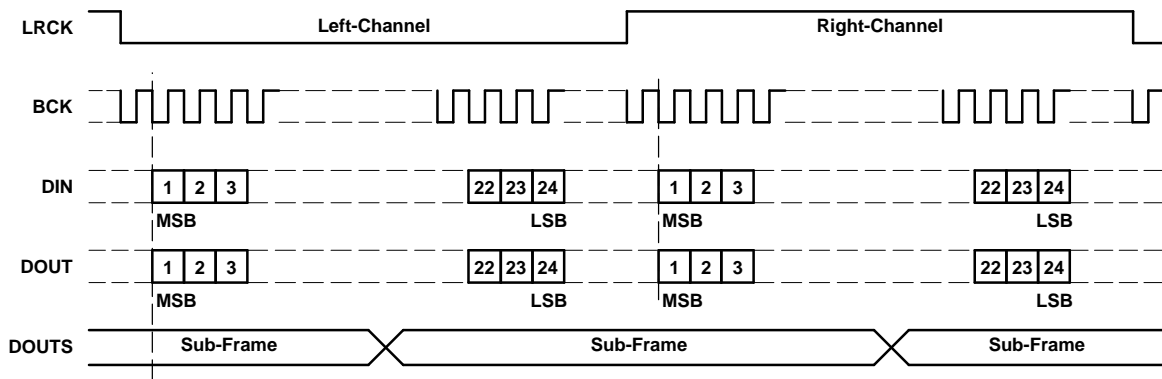

T0016-15

Figure 46. Audio Data Input/Output Format

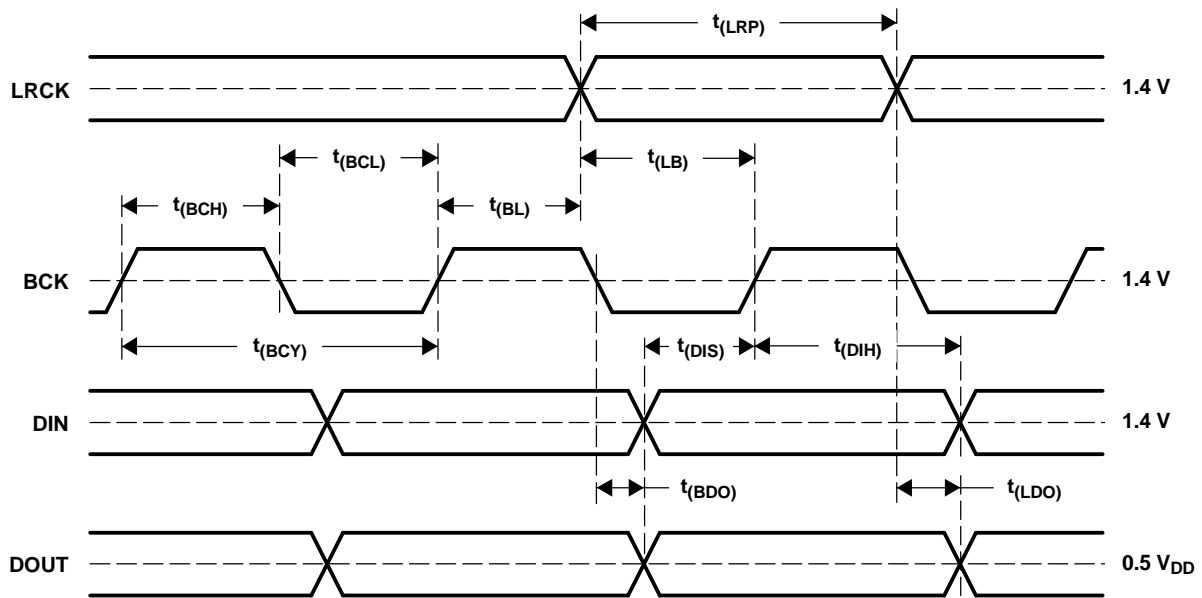

T0021–03

PARAMETER		MIN	MAX	UNIT
t_{BCY}	BCK pulse cycle time	160		ns
t_{BCH}	BCK pulse duration, HIGH	70		ns
t_{BCL}	BCK pulse duration, LOW	70		ns
t_{BL}	BCK rising edge to LRCK edge	20		ns
t_{LB}	LRCK edge to BCK rising edge	20		ns
t_{LRP}	LRCK pulse duration	4.2		μ s
t_{DIS}	DIN setup time to BCK rising edge	20		ns
t_{DIH}	DIN hold time to BCK rising edge	20		ns
t_{BDO}	DOUT delay time from BCK falling edge		20	ns
t_{LDO}	DOUT delay time from LRCK edge		20	ns
t_R	Rising time of all signals		10	ns
t_F	Falling time of all signals		10	ns

NOTE: Load capacitance at DOUT is 20 pF. Rising and falling time is measured from 10% to 90% of IN/OUT signal swing.

Figure 47. Audio Data Input/Output Timing

SYNCHRONIZATION WITH DIGITAL AUDIO SYSTEM

The PCM3052A operates with LRCK and BCK synchronized to the system clock in slave mode. The PCM3052A does not need specific phase relationship among LRCK, BCK, and the system clock, but does require the synchronization of LRCK, BCK, and the system clock.

If the relationship between system clock and LRCK changes more than ± 6 BCKs during one sample period due to LRCK jitter, etc., internal operation of DAC halts within $6/f_s$, and the analog output is forced to $0.5 V_{CC2}$ until re-synchronization of the system clock to LRCK and BCK has completed and then the time of $t_{(DACDLY2)}$ has elapsed.

DOUTS is also held LOW during the same period.

Internal operation of the ADC also halts within $6/f_s$, and digital output is forced into ZERO code until re-synchronization of the system clock to LRCK and BCK has completed and then the time of $t_{(ADC DLY2)}$ has elapsed.

In case of changes less than ± 5 BCKs, re-synchronization does not occur and the previously described analog/digital output control and discontinuity does not occur.

Figure 48 illustrates the DAC analog output, ADC digital output, and DOUTS output for loss of synchronization.

During undefined data, the PCM3052A can generate some noise in audio signal. Also, the transition of normal to undefined data and undefined or zero data to normal creates a discontinuity of data on analog and digital outputs, which could generate some noise in audio signal.

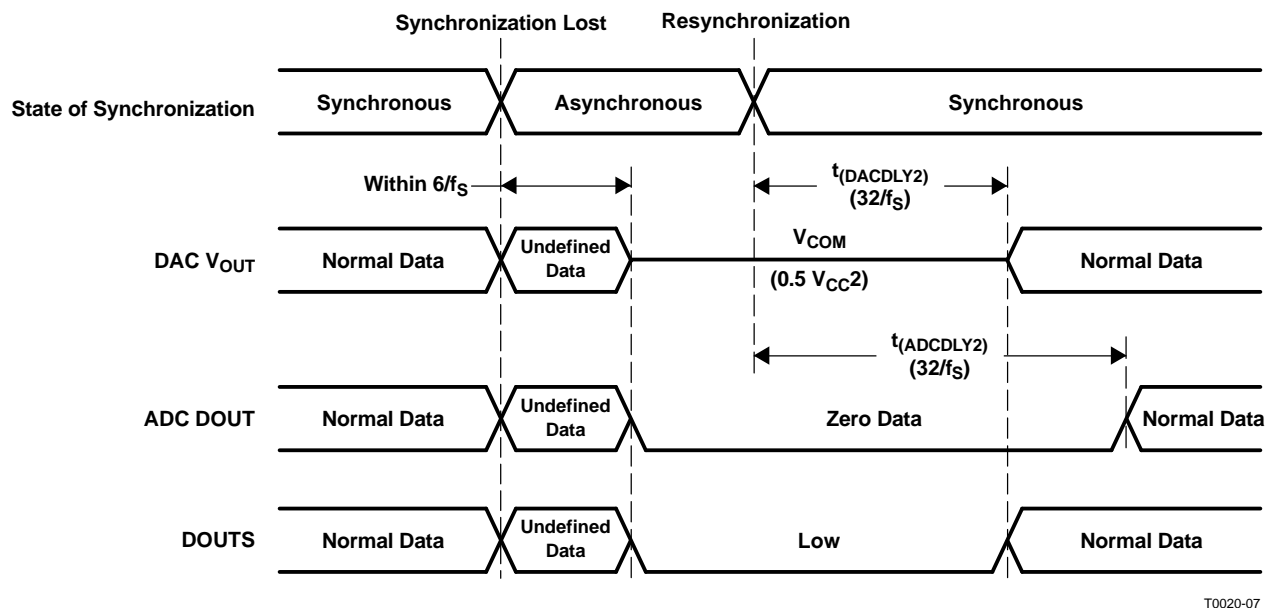

Figure 48. DAC Output and ADC Output for Loss of Synchronization

T0020-07

MICROPHONE AMPLIFIER AND MICROPHONE BIAS GENERATOR

The PCM3052A has a built-in, high-performance differential-input microphone amplifier with 34-dB gain, 5-k Ω (minimum) input resistance, and 59-dB SNR at 100-mV_{rms} output. Bandwidth is 20 kHz for -3 -dB attenuation. The PCM3052A also has a low-noise microphone bias generator with $0.75 V_{CC1}$ and 1-mA current-source capability for electret microphones. Output impedance is 48 Ω for external noise reduction. The output of the microphone amplifier and the line input are connected as inputs to the multiplexer. The serial control port can be used to control which input the multiplexer selects (see Figure 50).

REFERENCE OUTPUT

The PCM3052A has a reference output pin (RFFO, pin 32) to supply reference voltage ($0.5 V_{CC1}$) to external components. The pin has 10-mA sink/source capability with $6\text{-}\Omega$ output impedance.

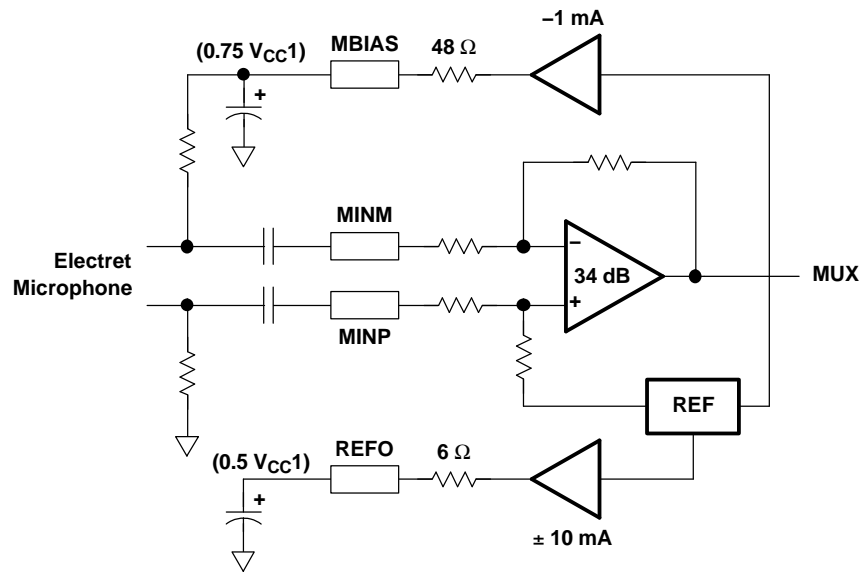

S0124-01

Figure 49. Microphone Amplifier, Microphone Bias Generator, and Reference Output

LINE AND MICROPHONE INPUT SELECT INDICATOR

The PCM3052A employs an indicator pin (L/\bar{M} , pin 3) to show which analog input is selected, line or microphone.

Table 3. Line and Microphone Select Indicator

L/\bar{M}	LINE/MIC SELECT INDICATOR
LOW	Microphone
HIGH	Line

MULTIPLEXER AND PGA

The PCM3052A has built-in analog front-end circuit which is shown in Figure 50. Multiplexer input and PGA gain are selected by mode control via the serial port, as shown in the *Serial Control Port for Mode Control* section. The full-scale input voltage range is 0.1 V_{rms} to 1.5 V_{rms}, and it can be adjusted to an adequate level for following the ADC sections.

V_{INL} and V_{INR} input resistance is maintained above 22 kΩ for all PGA gains. The input resistance value for each gain can be calculated by Equation 1.

$$R_{IN}(k\Omega, \text{ typical}) = \frac{286}{1 + 10^{(\text{PGA Gain}/20)}} \quad (1)$$

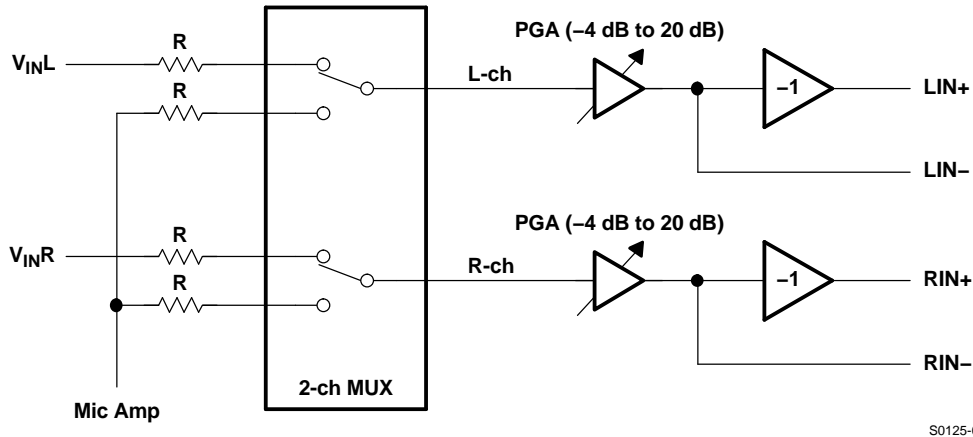

Figure 50. Multiplexer and PGA

ANALOG OUTPUTS FROM DAC

The PCM3052A has two independent output channels, V_{OUTL} and V_{OUTR}. These are unbalanced outputs, each capable of driving 4 V_{p-p} (typical) into a 5-kΩ ac-coupled load. The internal output amplifiers for V_{OUTL} and V_{OUTR} are biased to the dc common-mode (or bipolar zero) voltage, equal to 0.5 V_{CC2}.

The output amplifiers include an RC continuous-time filter, which helps to reduce the out-of-band noise energy present at the DAC outputs due to the noise-shaping characteristics of the PCM3052A delta-sigma modulators. The frequency response of this filter is shown in the typical performance curves. By itself, this filter is not adequate to attenuate the out-of-band noise to an acceptable level for many applications. An external low-pass filter is required to provide sufficient out-of-band noise rejection. Further discussion of DAC post-filter circuits is provided in the PCM1742 data sheet (SBAS176).

VCOM OUTPUT FOR DAC

One unbuffered common-mode voltage output pin, V_{COM} (pin 26), is brought out for decoupling purposes. This pin is nominally biased to a dc voltage level equal to 0.5 V_{CC2}. This pin can be used to bias external circuits. Output resistance of this pin is 21 kΩ (typical).

DIGITAL AUDIO INTERFACE TRANSMITTER (DIT)

The PCM3052A employs S/PDIF output from DOUTS (pin 14). The data (I²S format only) from DAC digital data input (DIN, pin 12) is encoded to S/PDIF format with preambles according to IEC958. S/PDIF output is controlled through the serial control port. The output data type (linear PCM or AC-3) can be also selected through the serial control port. For the output data type of AC-3, the word length is limited to 16 bits in the PCM3052A. Therefore, bits 17 to 24 in the I²S format data must be set to LOW.

Each bit after the audio sample word is assigned in the PCM3052A as follows.

- Validity bit: Writable through serial control port
- User data: Fixed to 0
- Channel status [0]: Fixed to 0 (consumer use)
- Channel status [1]: Writable through serial control port (audio sample word type)
- Channel status [2]: Writable through serial control port (copyright flag)
- Channel status [3:5]: Writable through serial control port (additional format information)
- Channel status [6:7]: Fixed to 00 (mode 0)
- Channel status [8:15]: Writable through serial control port (category code)
- Channel status [16:19]: Fixed to 0000 (source number)
- Channel status [20:23]: Fixed to 0000 (channel number)
- Channel status [24:27]: Writable through serial control port (sampling frequency)
- Channel status [28:29]: Writable through serial control port (clock accuracy)
- Channel status [30:31]: Fixed to 00
- Channel status [32:35]: Writable through serial control port (word length)
- Channel status [36:191]: Fixed to all 0s
- Parity bit: Even parity for preceding data from preamble to channel status bit

S/PDIF output timing is shown in Figure 51. The S/PDIF block starts with a preamble after $32/f_s$ from the frame where S/PDIF output control bit becomes HIGH. The behavior of DOUTS for power-on reset, external reset, and loss of synchronization is shown in Figure 44, Figure 45, and Figure 48, respectively.

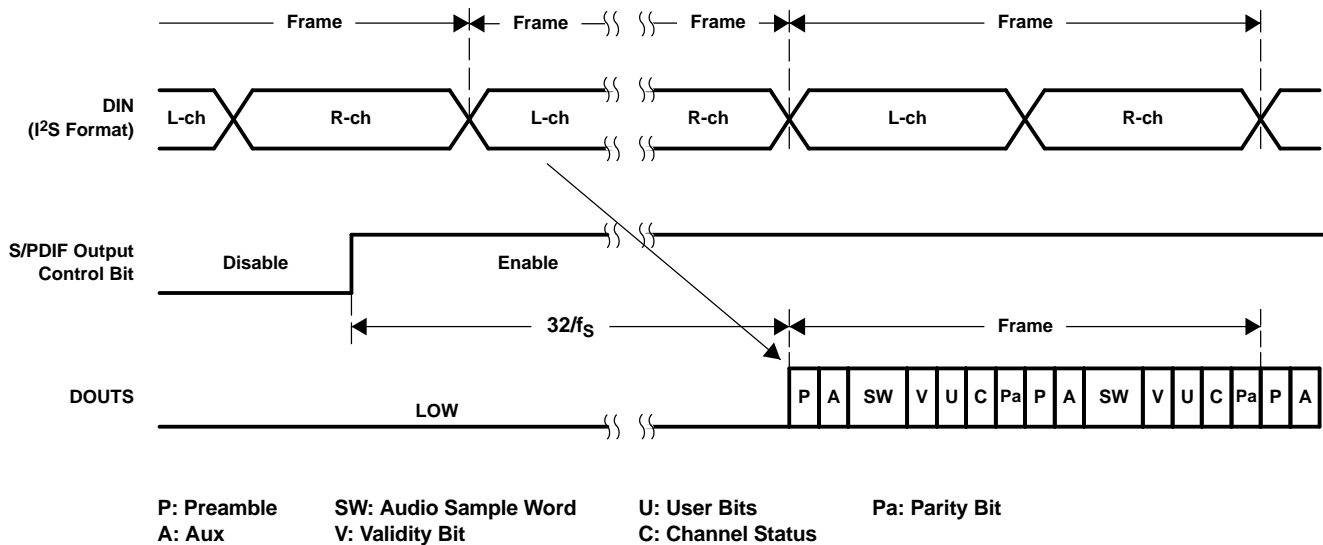

T0099-01

Figure 51. S/PDIF Output Timing

SERIAL CONTROL PORT FOR MODE CONTROL

The several built-in functions of the PCM3052A can be controlled through the I²C format serial-control port, SDA (pin 18) and SCL (pin 19). The PCM3052A supports the I²C serial bus and the data transmission protocol for standard mode as a slave device. This protocol is explained in I²C specification 2.0.

Serial control is available even during the power-down state and without a system clock, except when the MRST bit = 0 or I2CEN (pin 21) = LOW.

Slave Address

MSB						LSB	
1	0	0	0	1	1	ADR	R/ \bar{W}

The PCM3052A has seven bits for its own slave address. The first six bits (MSBs) of the slave address are factory preset to 100011. The next bit of the address byte is the device select bit which can be user-defined by ADR (pin 20). A maximum of two PCM3052As can be connected on the same bus at one time. Each PCM3052A responds when it receives its own slave address.

Packet Protocol

A master device must control packet protocol, which consists of start condition, slave address with read/write bit, data if write or acknowledgement if read, and stop condition. The PCM3052A supports slave receiver function.

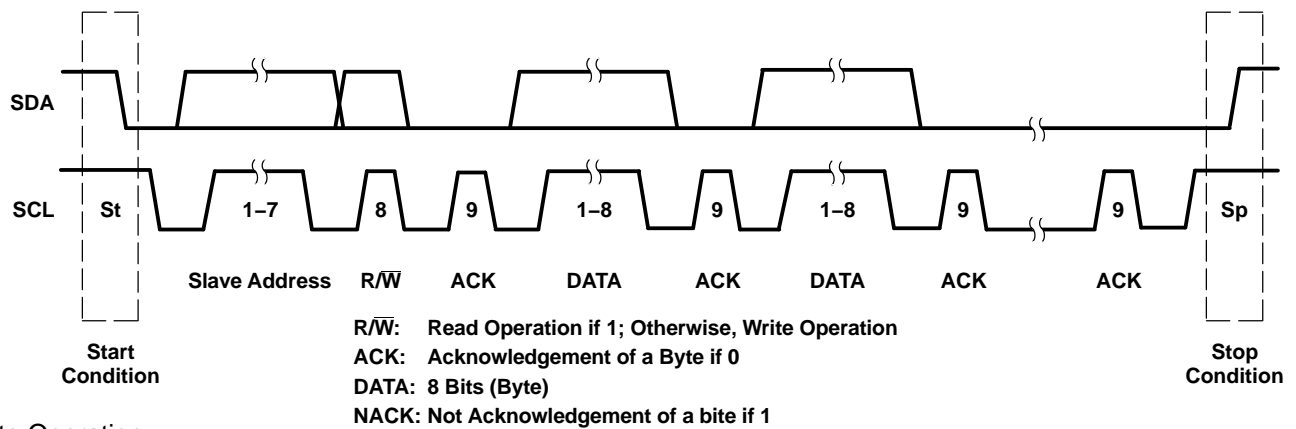

Write Operation

Transmitter	M	M	M	S	M	S	M	S		S	M
Data Type	St	Slave Address	\bar{W}	ACK	DATA	ACK	DATA	ACK		ACK	Sp

M: Master Device S: Slave Device
 St: Start Condition \bar{W} : Write Sp: Stop Condition

T0049-04

Figure 52. Basic I²C Framework

Write Operation

The PCM3052A supports receiver function. A master can write to any PCM3052A registers using single or multiple accesses. The master sends a PCM3052A slave address with a write bit, a register address, and the data. If multiple access is required, the address is that of the starting register, followed by the data to be transferred. When the data are received properly, the index register is incremented by 1 automatically. When the index register reaches 50h, the next value is 41h. When undefined registers are accessed, the PCM3052A does not send an acknowledgement. [Figure 53](#) is a diagram of the write operation. The register address and the write data are 8 bits and MSB-first format.

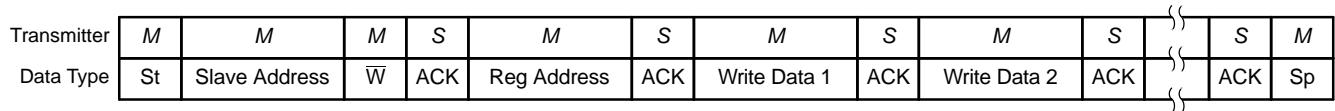

M: Master Device S: Slave Device
 St: Start Condition ACK: Acknowledge \bar{W} : Write Sp: Stop Condition

R0002-03

Figure 53. Framework for Write Operation

Serial Control Enable/Disable

The PCM3052A supports I²C serial control enable/disable function by I2CEN (pin 21) to avoid an unstable start condition. When the I2CEN pin transitions from LOW to HIGH, both SDA (pin 18) and SCL (pin 19) must be HIGH stable and the ADR (pin 20) must be also stable.

While I2CEN = LOW, the write operation is disabled. A timing chart of I2CEN is shown in [Figure 54](#).

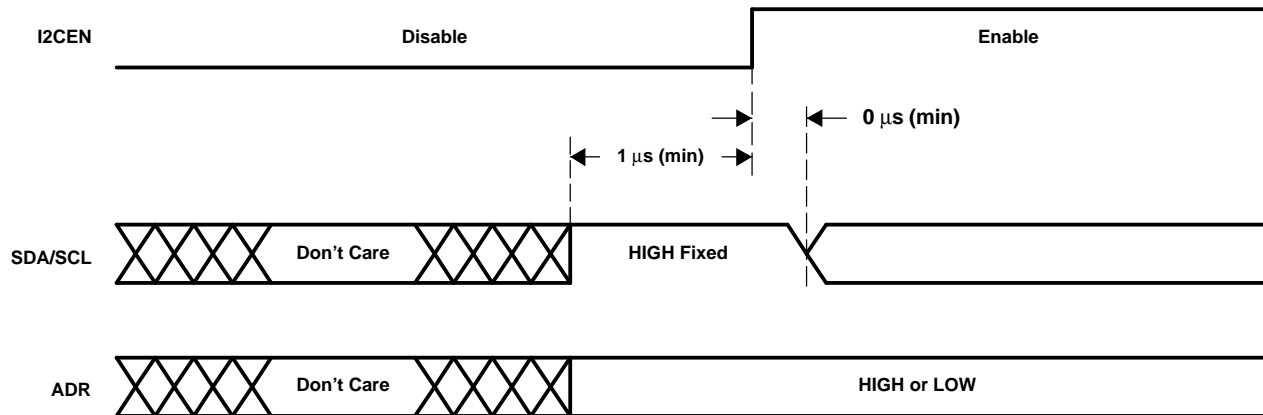

T0100-01

Figure 54. I2CEN Timing Chart

TIMING DIAGRAM

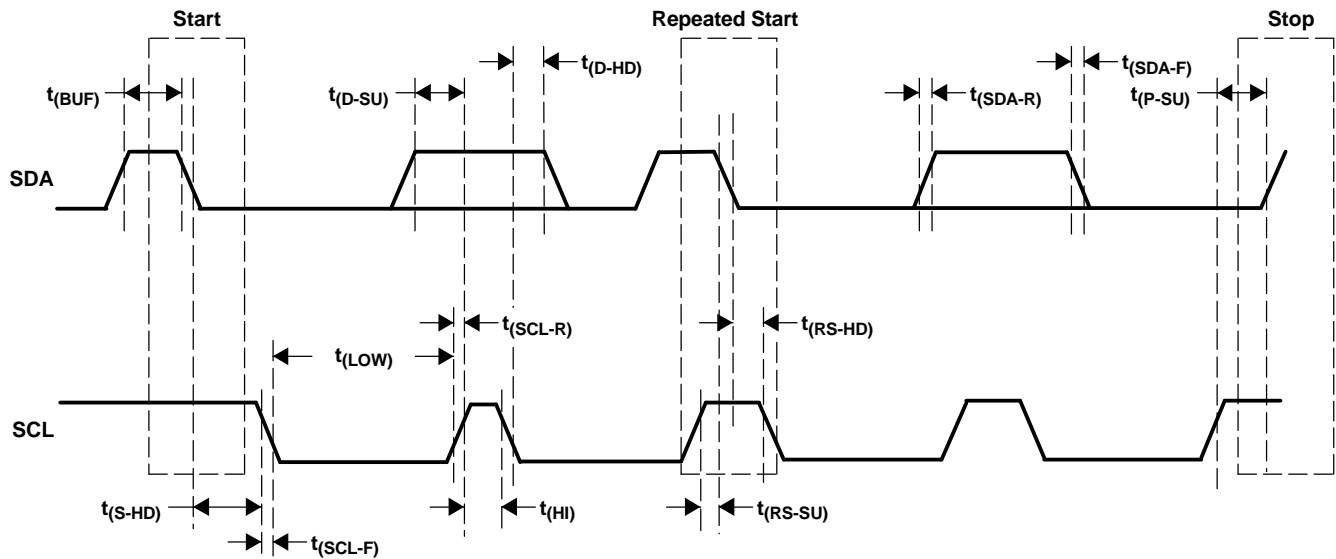

T0050-01

PARAMETER		CONDITIONS	MIN	MAX	UNIT
$f_{(SCL)}$	SCL clock frequency	Standard mode		100	kHz
$t_{(BUF)}$	Bus free time between STOP and START condition	Standard mode	4.7		μ s
$t_{(LOW)}$	Low period of the SCL clock	Standard mode	4.7		μ s
$t_{(HI)}$	High period of the SCL clock	Standard mode	4		μ s
t_{RS-SU}	Setup time for START/repeated START condition	Standard mode	4.7		μ s
$t_{(S-HD)}$ $t_{(RS-HD)}$	Hold time for START/repeated START condition	Standard mode	4		μ s
$t_{(D-SU)}$	Data setup time	Standard mode	250		ns
$t_{(D-HD)}$	Data hold time	Standard mode	0	900	ns
$t_{(SCL-R)}$	Rise time of SCL signal	Standard mode	$20 + 0.1 C_B$	1000	ns
$t_{(SCL-R1)}$	Rise time of SCL signal after a repeated START condition and after an acknowledge bit	Standard mode	$20 + 0.1 C_B$	1000	ns
$t_{(SCL-F)}$	Fall time of SCL signal	Standard mode	$20 + 0.1 C_B$	1000	ns
$t_{(SDA-R)}$	Rise time of SDA signal	Standard mode	$20 + 0.1 C_B$	1000	ns
$t_{(SDA-F)}$	Fall time of SDA signal	Standard mode	$20 + 0.1 C_B$	1000	ns
$t_{(P-SU)}$	Setup time for STOP condition	Standard mode	4		μ s
C_B	Capacitive load for SDA and SCL line			400	pF
V_{NH}	Noise margin at high level for each connected device (including hysteresis)	Standard mode	$0.2 V_{DD}$		V

Figure 55. Control Interface Timing

MODE CONTROL REGISTERS

User-Programmable Mode Controls

The PCM3052A has several user programmable functions which are accessed via control registers. The registers are programmed using the I²C serial control port, which was previously discussed in this data sheet. [Table 4](#) lists the available mode control functions, along with their reset default conditions and associated register addresses. The register map is shown in [Table 5](#).

Table 4. User-Programmable Mode Controls

FUNCTION	RESET DEFAULT	REGISTER	BIT(S)
Digital attenuation control, 0 dB to –63 dB in 0.5-dB steps (DAC)	0 dB, no attenuation	65 and 66	AT1[7:0], AT2[7:0]
Mode control register reset (ADC and DAC)	Normal operation	67	MRST
System reset (ADC and DAC)	Normal operation	67	SRST
ADC power-save control (ADC)	Normal operation	67	ADPSV
DAC Power Save Control (DAC)	Normal operation	67	DAPSV
Soft-mute control (DAC)	Mute disabled	68	MUT[2:1]
Oversampling rate control (DAC)	64- f_s oversampling	68	OVR1
De-emphasis function control (DAC)	De-emphasis disabled	69	DM12
De-emphasis sampling rate selection (DAC)	48 kHz	69	DMF[1:0]
Digital filter rolloff control (DAC)	Sharp rolloff	70	FLT0
Output phase select (DAC)	Normal	71	DREV
Multiplexer input channel control (ADC)	LINE IN	72	AML
PGA gain control (ADC)	–4 dB	72	PG[4:0]
HPF bypass control (ADC)	HPF enabled	75	BYP
DAC output control (DAC)	Disabled	77	DACMSK
Additional format information (DIT)	Two audio channels without pre-emphasis	77	AFI[5:3]
Copyright flag (DIT)	Asserted	77	COPY
Audio sample word type (DIT)	PCM	77	AUDIO
DIT output control (DIT)	Disable	77	DITMSK
Category code (DIT)	General	78	CAT[15:8]
Clock accuracy (DIT)	Level II	79	CLK[29:28]
Sampling frequency (DIT)	44.1kHz	79	SF[27:24]
Validity bit for L-channel (DIT)	Valid	80	VALIDL
Validity bit for R-channel (DIT)	Valid	80	VALIDR
S/PDIF output control (DIT)	Disabled	80	SPDIF
Word Length (DIT)	24 bits	80	WL[35:32]

Table 5. Register Map

REGISTER ADDRESS		DATA															
IDX (B8–B14)	REGIS-TER	B15	B14	B13	B12	B11	B10	B9	B8	B7	B6	B5	B4	B3	B2	B1	B0
41h	65	0	1	0	0	0	0	0	1	AT17	AT16	AT15	AT14	AT13	AT12	AT11	AT10
42h	66	0	1	0	0	0	0	1	0	AT27	AT26	AT25	AT24	AT23	AT22	AT21	AT20
43h	67	0	1	0	0	0	0	1	1	MRST	SRST	ADPSV	DAPSV	RSV ⁽¹⁾	RSV ⁽¹⁾	RSV ⁽¹⁾	RSV ⁽¹⁾
44h	68	0	1	0	0	0	1	0	0	RSV ⁽¹⁾	OVR1	RSV ⁽¹⁾	RSV ⁽¹⁾	RSV ⁽¹⁾	RSV ⁽¹⁾	MUT2	MUT1
45h	69	0	1	0	0	0	1	0	1	RSV ⁽¹⁾	DMF1	DMF0	DM12	RSV ⁽¹⁾	RSV ⁽¹⁾	RSV ⁽¹⁾	RSV ⁽¹⁾
46h	70	0	1	0	0	0	1	1	0	RSV ⁽¹⁾	RSV ⁽¹⁾	FLT0	RSV ⁽¹⁾	RSV ⁽¹⁾	1	RSV ⁽¹⁾	RSV ⁽¹⁾
47h	71	0	1	0	0	0	1	1	1	RSV ⁽¹⁾	RSV ⁽¹⁾	RSV ⁽¹⁾	RSV ⁽¹⁾	RSV ⁽¹⁾	RSV ⁽¹⁾	RSV ⁽¹⁾	DREV
48h	72	0	1	0	0	1	0	0	0	RSV ⁽¹⁾	RSV ⁽¹⁾	AML	PG4	PG3	PG2	PG1	PG0
4Bh	75	0	1	0	0	1	0	1	1	RSV ⁽¹⁾	RSV ⁽¹⁾	RSV ⁽¹⁾	RSV ⁽¹⁾	BYP	1	RSV ⁽¹⁾	RSV ⁽¹⁾
4Dh	77	0	1	0	0	1	1	0	1	DACMSK	RSV ⁽¹⁾	AFI5	AFI4	AFI3	COPY	AUDIO	DITMSK
4Eh	78	0	1	0	0	1	1	1	0	CAT15	CAT14	CAT13	CAT12	CAT11	CAT10	CAT9	CAT8
4Fh	79	0	1	0	0	1	1	1	1	RSV ⁽¹⁾	RSV ⁽¹⁾	CLK29	CLK28	SF27	SF26	SF25	SF24
50h	80	0	1	0	1	0	0	0	0	VALIDL	VALIDR	SPDIF	RSV ⁽¹⁾	WL35	WL34	WL33	WL32

(1) RSV means reserved for test operation or future extension, and these bits should be set 0 during regular operation. Do not write any values in other addresses than those listed in the table.

REGISTER DEFINITIONS

	B15	B14	B13	B12	B11	B10	B9	B8	B7	B6	B5	B4	B3	B2	B1	B0
REGISTER 65	0	1	0	0	0	0	0	1	AT17	AT16	AT15	AT14	AT13	AT12	AT11	AT10
REGISTER 66	0	1	0	0	0	0	1	0	AT27	AT26	AT25	AT24	AT23	AT22	AT21	AT20

ATx[7:0]: Digital Attenuation Level Setting (DAC)

Where x = 1 or 2, corresponding to the DAC output V_{OUTL} (x = 1) and V_{OUTR} (x = 2).

Default value: 1111 1111b

ATX[7:0]	DECIMAL VALUE	ATTENUATION LEVEL SETTING
1111 1111b	255	0 dB, No Attenuation. (default)
1111 1110b	254	-0.5 dB
1111 1101b	253	-1.0 dB
:	:	:
1000 0011b	131	-62.0 dB
1000 0010b	130	-62.5 dB
1000 0001b	129	-63.0 dB
1000 0000b	128	Mute
:	:	:
0000 0000b	0	Mute

Each DAC channel (V_{OUTL} and V_{OUTR}) includes a digital attenuation function. The attenuation level can be set from 0 dB to -63 dB in 0.5-dB steps, and also can be set to infinite attenuation (mute). The attenuation level change from current value to target value is performed by incrementing or decrementing by one small step size for every $1/f_S$ time interval during $2048/f_S$. The small step size is determined automatically so that it can provide a transition in attenuation level with a characteristic S-shaped curve from the current value to the target value. While the attenuation level change sequence is in progress for $2048/f_S$, processing of the attenuation level change for any new command is ignored, and the new command is overwritten into command buffer. The last command for an attenuation level change is performed after present attenuation level change sequence is finished.

The attenuation data for each channel can be set individually. The attenuation level can be calculated using the following formula:

$$\text{Attenuation level (dB)} = 0.5 \times (\text{ATx}[7:0]_{\text{DEC}} - 255)$$

where $\text{ATx}[7:0]_{\text{DEC}} = 0$ through 255.

For $\text{ATx}[7:0]_{\text{DEC}} = 0$ through 128, attenuation is set to infinite attenuation.

The preceding table shows attenuation levels for various settings.

	B15	B14	B13	B12	B11	B10	B9	B8	B7	B6	B5	B4	B3	B2	B1	B0
REGISTER 67	0	1	0	0	0	0	1	1	MRST	SRST	ADPSV	DAPSV	RSV	RSV	RSV	RSV

MRST: Mode Control Register Reset (ADC and DAC)

Default value: 1

MRST = 0	Set default value
MRST = 1	Normal operation (default)

The MRST bit controls mode control register reset. Pop-noise may be generated.

SRST: System Reset (ADC and DAC)

Default value: 1

SRST = 0	Re-synchronization
SRST = 1	Normal operation (default)

The SRST bit controls system reset. The PCM3052A does not go into power-down state. The mode control register is not reset by this control. Also pop-noise may be generated.

ADPSV: ADC Power-Save Control (ADC)

Default value: 0

ADPSV = 0	Normal operation (default)
ADPSV = 1	Power-save mode

The ADPSV bit controls ADC power-save mode. In power-save mode, ADC goes into power-down state, the data in ADC are reset, and DOUT is forced into ZERO immediately. I²C control is enabled.

DAPSV: DAC Power-Save Control (DAC)

Default value: 0

DAPSV = 0	Normal operation (default)
DAPSV = 1	Power-save mode

The DAPSV bit controls the DAC power-save mode. In the power-save mode, the DAC output is faded out and DAC goes into the power-down state. I²C control is enabled. A waiting time of more than 2100/f_s from power-save-mode assertion is required for the release of the power-save mode.

DIT function is available if SPDIF bit = 1, even though DAPSV = 1.

	B15	B14	B13	B12	B11	B10	B9	B8	B7	B6	B5	B4	B3	B2	B1	B0
REGISTER 68	0	1	0	0	0	1	0	0	RSV	OVR1	RSV	RSV	RSV	RSV	MUT2	MUT1

OVR1: Oversampling Rate Control (DAC)

Default value: 0

OVR1 = 0	64x oversampling (default)
OVR1 = 1	128x oversampling

The OVR1 bit is used to control the oversampling rate of the delta-sigma D/A converters. To write over this register during normal operation may generate noise.

MUTx: Soft-Mute Control (DAC)

where, x = 1 or 2, corresponding to the DAC output V_{OUTL} (x = 1) and V_{OUTR} (x = 2).

Default value: 0

MUTx = 0	Mute disabled (default)
MUTx = 1	Mute enabled

The mute bits, MUT1 and MUT2, are used to enable or disable the soft-mute function for the corresponding DAC outputs, V_{OUTL} and V_{OUTR}. The soft-mute function is incorporated into the digital attenuators. When mute is disabled (MUTx = 0), the attenuator and DAC operate normally. When mute is enabled by setting MUTx = 1, the digital attenuator for the corresponding output is decreased from the current setting to infinite attenuation, one attenuator step (0.5 dB) for every 8/f_s seconds. This provides *pop-free* muting of the DAC output.

By setting MUTx = 0, the attenuator is increased one step for every 8/f_s seconds to the previously programmed attenuation level.

	B15	B14	B13	B12	B11	B10	B9	B8	B7	B6	B5	B4	B3	B2	B1	B0
REGISTER 69	0	1	0	0	0	1	0	1	RSV	DMF1	DMF0	DM12	RSV	RSV	RSV	RSV

DMF[1:0]: Sampling Frequency Selection for the De-Emphasis Function (DAC)

Default value: 01

DMF[1:0]	DE-EMPHASIS SAMPLING RATE SELECTION
00	44.1 kHz
01	48 kHz (default)
10	32 kHz
11	Reserved

The DMF[1:0] bits are used to select the sampling frequency used for the digital de-emphasis function when it is enabled.

DM12: Digital De-Emphasis Function Control (DAC)

Default value: 0

DM12 = 0	De-emphasis disabled (default)
DM12 = 1	De-emphasis enabled

The DM12 bit is used to enable or disable the digital de-emphasis function. See the plots shown in the *Typical Performance Curves* section of this data sheet.

	B15	B14	B13	B12	B11	B10	B9	B8	B7	B6	B5	B4	B3	B2	B1	B0
REGISTER 70	0	1	0	0	0	1	1	0	RSV	RSV	FLT0	RSV	RSV	1	RSV	RSV

FLT0: Digital Filter Rolloff Control (DAC)

Default value: 0

FLT0 = 0	Sharp rolloff (default)
FLT0 = 1	Slow rolloff

The FLT0 bit allows the user to select the digital filter rolloff that is best suited to their application. Two filter rolloff selections are available: Sharp and Slow. The filter responses for these selections are shown in the *Typical Performance Curves* section of this data sheet.

	B15	B14	B13	B12	B11	B10	B9	B8	B7	B6	B5	B4	B3	B2	B1	B0
REGISTER 71	0	1	0	0	0	1	1	1	RSV	RSV	RSV	RSV	RSV	RSV	RSV	DREV

DREV: Output Phase Select (DAC)

Default value: 0

DREV = 0	Normal output (default)
DREV = 1	Inverted output

The DREV bit is used to control the output analog signal phase control.

	B15	B14	B13	B12	B11	B10	B9	B8	B7	B6	B5	B4	B3	B2	B1	B0
REGISTER 72	0	1	0	0	1	0	0	0	RSV	RSV	AML	PG4	PG3	PG2	PG1	PG0

AML: Multiplexer Input Channel Selection (ADC)

Default value: 0

AML	MULTIPLEXER INPUT CHANNEL SELECTION
0	Line (default)
1	Microphone

The AML bit selects the input channel of multiplexer.

PG[4:0]: PGA Gain Selection (ADC)

Default value: 0 0100 (–4 dB)

PG[4:0]	PGA Gain Selection	PG[4:0]	PGA Gain Selection
11111	Digital mute	01111	7 dB
11110	Digital mute	01110	6 dB
11101	Digital mute	01101	5 dB
11100	20 dB	01100	4 dB
11011	19 dB	01011	3 dB
11010	18 dB	01010	2 dB
11001	17 dB	01001	1 dB
11000	16 dB	01000	0 dB
10111	15 dB	00111	– 1 dB
10110	14 dB	00110	–2 dB
10101	13 dB	00101	–3 dB
10100	12 dB	00100	–4 dB (default)
10011	11 dB	00011	Digital mute
10010	10 dB	00010	Digital mute
10001	9 dB	00001	Digital mute
10000	8 dB	00000	Digital mute

The PG[4:0] bits control the gain of PGA for adjusting the signal level for ADC.

	B15	B14	B13	B12	B11	B10	B9	B8	B7	B6	B5	B4	B3	B2	B1	B0
REGISTER 75	0	1	0	0	1	0	1	1	RSV	RSV	RSV	RSV	BYP	1	RSV	RSV

BYP: HPF Bypass Control (ADC)

Default value: 0

BYP = 0	Normal output, HPF enable (default)
BYP = 1	Bypass output, HPF disable

The BYP bit controls HPF function; dc components of input and dc offset are converted in bypass mode.

	B15	B14	B13	B12	B11	B10	B9	B8	B7	B6	B5	B4	B3	B2	B1	B0
REGISTER 77	0	1	0	0	1	1	0	1	DACMSK	RSV	AFI5	AFI4	AFI3	COPY	AUDIO	DITMSK

DACMSK: DAC Output Control (DAC)

Default value: 0

DACMSK = 0	Mask disable (default)
DACMSK = 1	Mask DIN to BPZ level

The DACMSK bit is used to mask DIN to BPZ level. The analog outputs from DAC is forced to BPZ level immediately. Larger noise may be generated by this control.

AFI[5:3]: Additional Format Information (DIT)

Default value: 000 (2 audio channels without pre-emphasis)

The AFI[5:3] bits control bits[5:3] of channel status bits in compliance with IEC958.

COPY: Copyright Flag (DIT)

Default value: 0 (Asserted)

The COPY bit controls bit[2] of channel status bits in compliance with IEC958.

AUDIO: Audio Sample Word Type (DIT)

Default value: 0 (PCM)

The AUDIO bit controls bit[1] of channel status bits in compliance with IEC958.

DITMSK: DIT Output Control (DIT)

Default value: 0

DITMSK = 0	Mask disable (default)
DITMSK = 1	Force DOUTS to encoded ZERO status

The DITMSK bit forces only aux and audio sample words on DOUTS to encoded ZERO status. As for validity and channel status bits, the values in the register are output.

	B15	B14	B13	B12	B11	B10	B9	B8	B7	B6	B5	B4	B3	B2	B1	B0
REGISTER 78	0	1	0	0	1	1	1	0	CAT15	CAT14	CAT13	CAT12	CAT11	CAT10	CAT9	CAT8

CAT[15:8]: Category Code (DIT)

Default value: 0000 0000 (general)

The CAT[15:8] bits control bits[15:8] of channel status bits in compliance with IEC958.

	B15	B14	B13	B12	B11	B10	B9	B8	B7	B6	B5	B4	B3	B2	B1	B0
REGISTER 79	0	1	0	0	1	1	1	1	RSV	RSV	CLK29	CLK28	SF27	SF26	SF25	SF24

CLK[29:28]: Clock Accuracy (DIT)

Default value: 00 (level II)

The CLK[29:28] bits control bits[29:28] of channel status bits in compliance with IEC958.

SF[27:24]: Sampling Frequency (DIT)

Default value: 0000 (44.1 kHz)

The SF[27:24] bits control bits[27:24] of channel status bits in compliance with IEC958.

	B15	B14	B13	B12	B11	B10	B9	B8	B7	B6	B5	B4	B3	B2	B1	B0
REGISTER 80	0	1	0	1	0	0	0	0	VALIDL	VALIDR	SPDIF	RSV	WL35	WL34	WL33	WL32

VALIDL: Validity Bit for L-channel (DIT)

Default value: 0 (valid)

The VALIDL bit controls the validity bit for L-channel in compliance with IEC958.

VALIDR: Validity Bit for R-channel (DIT)

Default value: 0 (valid)

The VALIDR bit controls validity bit for R-channel in compliance with IEC958.

SPDIF: S/PDIF Output Control (DIT)

Default value: 0

SPDIF = 0	DOUTS disabled (default)
SPDIF = 1	DOUTS enabled

The SPDIF bit controls output from DOUTS pin. In case of default, DOUTS always becomes LOW status.

WL[35:32]: Word Length (DIT)

Default value: 0001 (24 bits)

The WL[35:32] bits control bits[35:32] of channel status bits and the actual data word length of audio sample word including auxiliary 4-bits from DOUTS pin in compliance with IEC958. If the WL[35:32] bits indicate 16 bits, the actual data word length of audio sample word is limited to 16 bits even though data input on DIN pin is 24-bits, for example.

TYPICAL CIRCUIT CONNECTION

Figure 56 illustrates typical circuit connection.

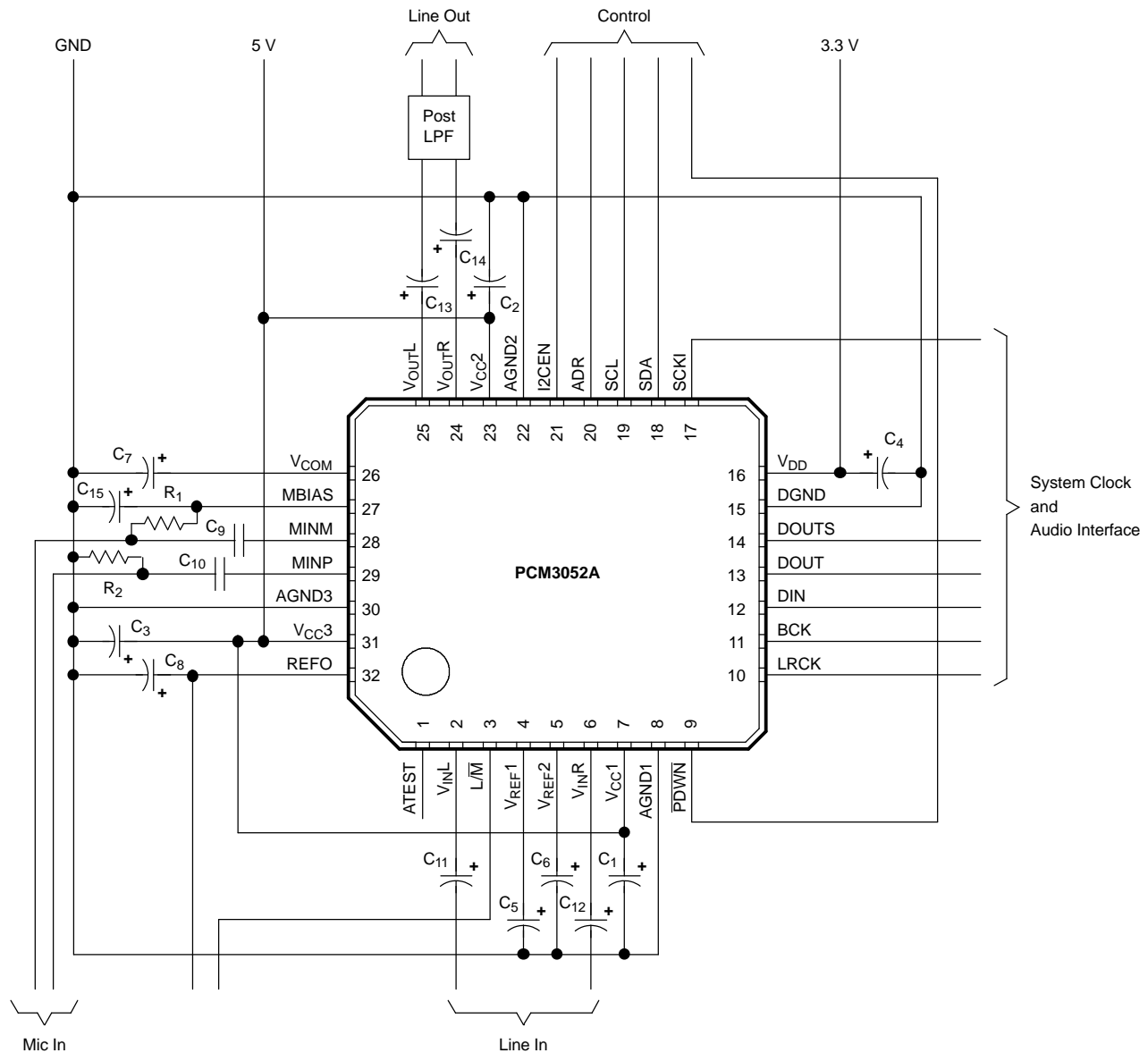

S0126-01

NOTE: C₁– C₄: 0.1- μ F ceramic and 10- μ F electrolytic capacitors typical, depending on power supply quality and pattern layout.

C₅– C₈: 0.1- μ F ceramic and 10- μ F electrolytic capacitors are recommended.

C₉, C₁₀: 1- μ F non-polar electrolytic capacitors are recommended, which give 27-Hz cutoff frequency.

C₁₁, C₁₂: 0.22- μ F electrolytic capacitors are recommended, which give 5-Hz cutoff frequency at PGA gain = 0 dB.

C₁₃, C₁₄: 2.2- μ F capacitors are typical.

C₁₅: 10- μ F electrolytic capacitor is recommended.

R₁, R₂: 1-k Ω typical is recommended.

Figure 56. Typical Application Diagram

DESIGN AND LAYOUT CONSIDERATIONS IN APPLICATION

Power Supply Pins (V_{CC1} , V_{CC2} , V_{CC3} , V_{DD})

The digital and analog power supply lines to the PCM3052A should be bypassed to the corresponding ground pins with 0.1- μ F ceramic and 10- μ F electrolytic capacitors as close to the pins as possible to maximize the dynamic performance of the ADC and DAC.

Although the PCM3052A has four power lines to maximize the potential of dynamic performance, using one common 5-V power supply for V_{CC1} , V_{CC2} , and V_{CC3} . A 3.3-V power supply for V_{DD} , which is generated from the 5-V power supply for V_{CC1} , V_{CC2} , and V_{CC3} , is recommended to avoid unexpected power supply trouble like latch-up or power supply sequencing problems.

Grounding (AGND1, AGND2, AGND3, DGND)

To maximize the dynamic performance of the PCM3052A, the analog and digital grounds are not connected internally. These points should have low impedance to avoid digital noise and signal components feeding back into the analog ground. They should be connected directly to each other under the parts to reduce the potential of noise problems.

V_{INL} , V_{INR} Pins

A 0.22- μ F electrolytic capacitor is recommended as an ac-coupling capacitor, which gives a 5-Hz cutoff frequency at PGA gain = 0 dB. If higher full-scale input voltage is required, it can be adjusted by adding only one series resistor to V_{INX} pins.

V_{REF1} , V_{REF2} , V_{COM} Pins

Both 0.1- μ F ceramic and 10- μ F electrolytic capacitors are recommended from V_{REF1} and V_{REF2} to AGND1, and from V_{COM} to AGND2, to ensure low source impedance of the ADC and DAC references. These capacitors should be located as close as possible to the V_{REF1} , V_{REF2} , and V_{COM} pins to reduce dynamic errors on the ADC and DAC references.

MBIAS Pin

A 10- μ F electrolytic capacitor is recommended between MBIAS and AGND3 to ensure low noise on MBIAS.

REFO Pin

Both 0.1- μ F ceramic and 10- μ F electrolytic capacitors are recommended between REFO and AGND1 to ensure low noise on REFO.

MINM, MINP Pins

A 1- μ F non-polar electrolytic capacitor which gives a 27-Hz cutoff frequency, is recommended as coupling capacitor.

System Clock

The quality of SCKI can influence dynamic performance, as the PCM3052A (both of DAC and ADC) operates based on SCKI. Therefore, it might be necessary to consider the jitter, duty, rise and fall time, etc. of the system clock.

External Mute Control

For power-down ON/OFF control without click noise which is generated by DAC output dc level changes, the external mute control is generally required. The control sequence, which is described as *External Mute ON, CODEC Power Down ON, SCKI stop and resume if necessary, CODEC Power Down OFF, and External Mute OFF*, is recommended.

PACKAGING INFORMATION

Orderable part number	Status (1)	Material type (2)	Package Pins	Package qty Carrier	RoHS (3)	Lead finish/ Ball material (4)	MSL rating/ Peak reflow (5)	Op temp (°C)	Part marking (6)
PCM3052ARTF	Active	Production	VQFN (RTF) 32	250 JEDEC TRAY (10+1)	Yes	NIPDAU	Level-1-260C-UNLIM	-40 to 85	PCM3052A
PCM3052ARTF.B	Active	Production	VQFN (RTF) 32	250 JEDEC TRAY (10+1)	Yes	NIPDAU	Level-1-260C-UNLIM	-40 to 85	PCM3052A
PCM3052ARTFR	Active	Production	VQFN (RTF) 32	2000 LARGE T&R	Yes	NIPDAU	Level-1-260C-UNLIM	-40 to 85	PCM3052A
PCM3052ARTFR.B	Active	Production	VQFN (RTF) 32	2000 LARGE T&R	Yes	NIPDAU	Level-1-260C-UNLIM	-40 to 85	PCM3052A

(1) **Status:** For more details on status, see our [product life cycle](#).

(2) **Material type:** When designated, preproduction parts are prototypes/experimental devices, and are not yet approved or released for full production. Testing and final process, including without limitation quality assurance, reliability performance testing, and/or process qualification, may not yet be complete, and this item is subject to further changes or possible discontinuation. If available for ordering, purchases will be subject to an additional waiver at checkout, and are intended for early internal evaluation purposes only. These items are sold without warranties of any kind.

(3) **RoHS values:** Yes, No, RoHS Exempt. See the [TI RoHS Statement](#) for additional information and value definition.

(4) **Lead finish/Ball material:** Parts may have multiple material finish options. Finish options are separated by a vertical ruled line. Lead finish/Ball material values may wrap to two lines if the finish value exceeds the maximum column width.

(5) **MSL rating/Peak reflow:** The moisture sensitivity level ratings and peak solder (reflow) temperatures. In the event that a part has multiple moisture sensitivity ratings, only the lowest level per JEDEC standards is shown. Refer to the shipping label for the actual reflow temperature that will be used to mount the part to the printed circuit board.

(6) **Part marking:** There may be an additional marking, which relates to the logo, the lot trace code information, or the environmental category of the part.

Multiple part markings will be inside parentheses. Only one part marking contained in parentheses and separated by a "-" will appear on a part. If a line is indented then it is a continuation of the previous line and the two combined represent the entire part marking for that device.

Important Information and Disclaimer: The information provided on this page represents TI's knowledge and belief as of the date that it is provided. TI bases its knowledge and belief on information provided by third parties, and makes no representation or warranty as to the accuracy of such information. Efforts are underway to better integrate information from third parties. TI has taken and continues to take reasonable steps to provide representative and accurate information but may not have conducted destructive testing or chemical analysis on incoming materials and chemicals. TI and TI suppliers consider certain information to be proprietary, and thus CAS numbers and other limited information may not be available for release.

In no event shall TI's liability arising out of such information exceed the total purchase price of the TI part(s) at issue in this document sold by TI to Customer on an annual basis.

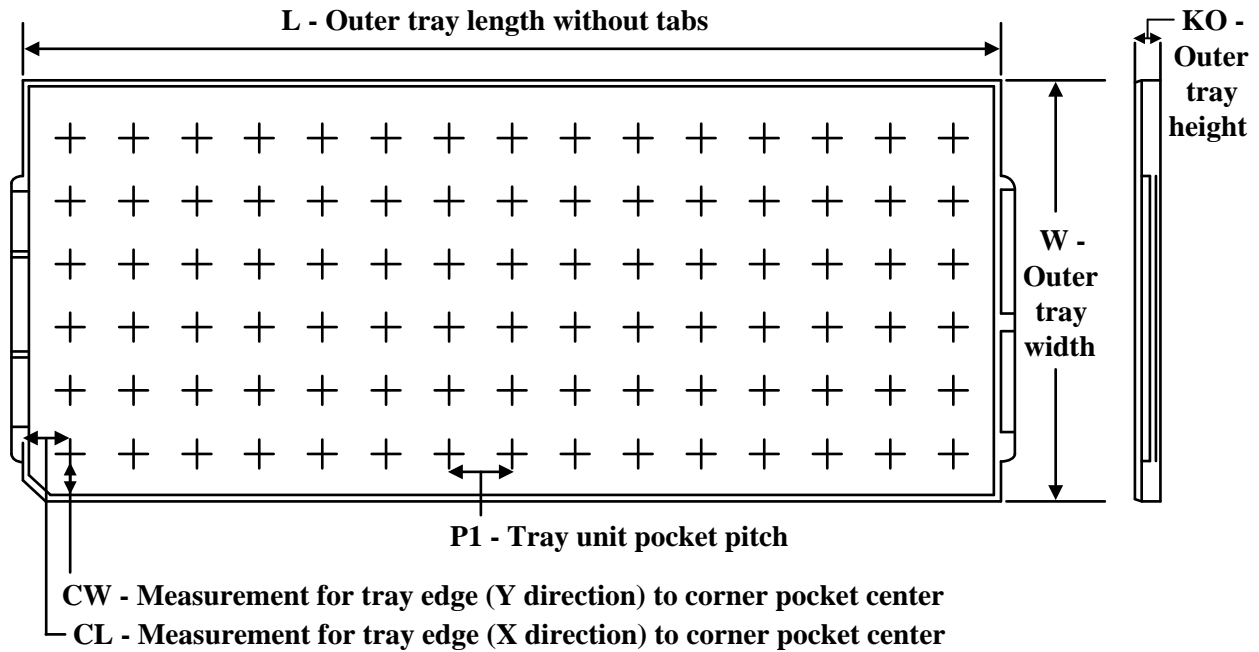
TRAY

Chamfer on Tray corner indicates Pin 1 orientation of packed units.

*All dimensions are nominal

Device	Package Name	Package Type	Pins	SPQ	Unit array matrix	Max temperature (°C)	L (mm)	W (mm)	K0 (µm)	P1 (mm)	CL (mm)	CW (mm)
PCM3052ARTF	RTF	VQFNP	32	250	10x25	150	315	135.9	7620	12.6	11.1	11.25
PCM3052ARTF.B	RTF	VQFNP	32	250	10x25	150	315	135.9	7620	12.6	11.1	11.25

IMPORTANT NOTICE AND DISCLAIMER

TI PROVIDES TECHNICAL AND RELIABILITY DATA (INCLUDING DATASHEETS), DESIGN RESOURCES (INCLUDING REFERENCE DESIGNS), APPLICATION OR OTHER DESIGN ADVICE, WEB TOOLS, SAFETY INFORMATION, AND OTHER RESOURCES "AS IS" AND WITH ALL FAULTS, AND DISCLAIMS ALL WARRANTIES, EXPRESS AND IMPLIED, INCLUDING WITHOUT LIMITATION ANY IMPLIED WARRANTIES OF MERCHANTABILITY, FITNESS FOR A PARTICULAR PURPOSE OR NON-INFRINGEMENT OF THIRD PARTY INTELLECTUAL PROPERTY RIGHTS.

These resources are intended for skilled developers designing with TI products. You are solely responsible for (1) selecting the appropriate TI products for your application, (2) designing, validating and testing your application, and (3) ensuring your application meets applicable standards, and any other safety, security, regulatory or other requirements.

These resources are subject to change without notice. TI grants you permission to use these resources only for development of an application that uses the TI products described in the resource. Other reproduction and display of these resources is prohibited. No license is granted to any other TI intellectual property right or to any third party intellectual property right. TI disclaims responsibility for, and you fully indemnify TI and its representatives against any claims, damages, costs, losses, and liabilities arising out of your use of these resources.

TI's products are provided subject to [TI's Terms of Sale](#), [TI's General Quality Guidelines](#), or other applicable terms available either on [ti.com](#) or provided in conjunction with such TI products. TI's provision of these resources does not expand or otherwise alter TI's applicable warranties or warranty disclaimers for TI products. Unless TI explicitly designates a product as custom or customer-specified, TI products are standard, catalog, general purpose devices.

TI objects to and rejects any additional or different terms you may propose.

Copyright © 2026, Texas Instruments Incorporated

Last updated 10/2025